



FWD Type B

Американский грузовой автомобиль I MB

Компания Four Wheel Drive Auto Company (FWD) была новаторской американской компанией, которая разрабатывала и производила полноприводные автомобили.

Армия США заказала 15 000 трехтонных грузовиков FWD Model B как «Грузовик, 3 тонны, модель 1917 года» во время Первой мировой войны с фактически поставленными более 14 000; дополнительные заказы поступили из Великобритании и России.

Технические характеристики автомобиля FWD Type B

Грузоподъемность, т	3
Длина, мм	5640
Ширина, мм	1930
Высота, мм.....	3200
База, мм	3150
Двигатель	«Висконсин», 4-цил., 36 л.с.
Максимальная скорость, км/ч	24

ВНИМАНИЕ!

Перед сборкой внимательно прочитать руководство по монтажу. Каждая деталь пронумерована. Соблюдать последовательность монтажа. Необходимые рабочие инструменты: нож и напильник для зачистки деталей; резиновая лента, клейкая лента и скотч для прижимания склеиваемых деталей. Детали из пластика очистить в растворе мягкого моющего средства и высушить на воздухе для того, чтобы краска и переводные картинки лучше прилипали. Перед приклеиванием проверить, подходят ли детали; клей наносить аккуратно. Хром и краску удалить с поверхностей склеивания. Небольшие детали покрасить перед тем, как они будут удалены из рамок. Краску необходимо хорошо просушить, только после этого продолжать сборку. Каждую соответствующую переводную картинку отдельно вырезать и примерно на 20 секунд окунуть в теплую воду. На обозначенном месте картинку отделить от бумаги и прижать промокающей бумагой.

FWD Type B

WW I US Army Truck

The Four Wheel Drive Auto Company (FWD), was a pioneering American company that developed and produced all-wheel drive vehicles.

The U.S. Army ordered 15,000 FWD Model B three ton trucks as the «Truck, 3 ton, Model 1917» during the World War I with over 14,000 actually delivered; additional orders came from the United Kingdom and Russia.

Technical Specifications of FWD Type B truck

Full load, t.....	3
Length, mm	5640
Width, mm	1930
Height, mm.....	3200
Wheel base, mm	3150
Engine	Wisconsin, 4 cyl., 36 hp
Max. Speed, km/h.....	24

CAUTION!

Read the instructions thoroughly prior to assembly. Each component is numbered. Adhere to specified sequence of assembly. Tools required: knife and file for removal of components from frame; rubber bond, adhesive tape and clothes pegs for clamping components together after applying adhesive. Clean plastic components in a mild detergent solution and allow to air-dry so that paint and transfers adhere better. Prior to applying adhesive, check to see whether the components fit together; apply adhesive sparingly. Remove chrome and paint from the contact surfaces. Paint small components before removing them from the frame. Allow paint to dry well, and only then continue to assemble. Cut out each transfer individually and immerse in warm water for approx. 20 seconds. Slide transfer off paper and into designated position, then press on with blotting paper.

▶ ИСПОЛЬЗУЕМЫЕ КРАСКИ / USED COLORS:

	Revell	Tamiya		
A	105	XF2	Белый, матовый	Flat White
B	107	X1	Черный, глянцевый	Gloss Black
C	302	X18	Черный, полуматовый	Semigloss Black
D	165	XF58	Оливково-зеленый, мат.	Olive Green
E	186	XF49	Хаки, матовый	Khaki

	Revell	Tamiya		
F	189	XF78	Дерево	Wood
G	191	X32	Сталь	Steel
H	190	X11	Серебристый	Chrome Silver
J	192	X33	Латунь	Brass
K	183	XF84	Ржавчина	Rust

01 СТАДИЯ СБОРКИ
ASSEMBLY STEP

x2 СДЕЛАТЬ ДВЕ ДЕТАЛИ
MAKE 2 PCS

✂ ОТРЕЗАТЬ
CUT OFF

03 СБОРОЧНАЯ ЕДИНИЦА
ASSEMBLY UNIT

? ПРОИЗВОЛЬНЫЙ ВЫБОР
OPTIONAL

A ИСПОЛЬЗУЕМАЯ КРАСКА
USED COLOR

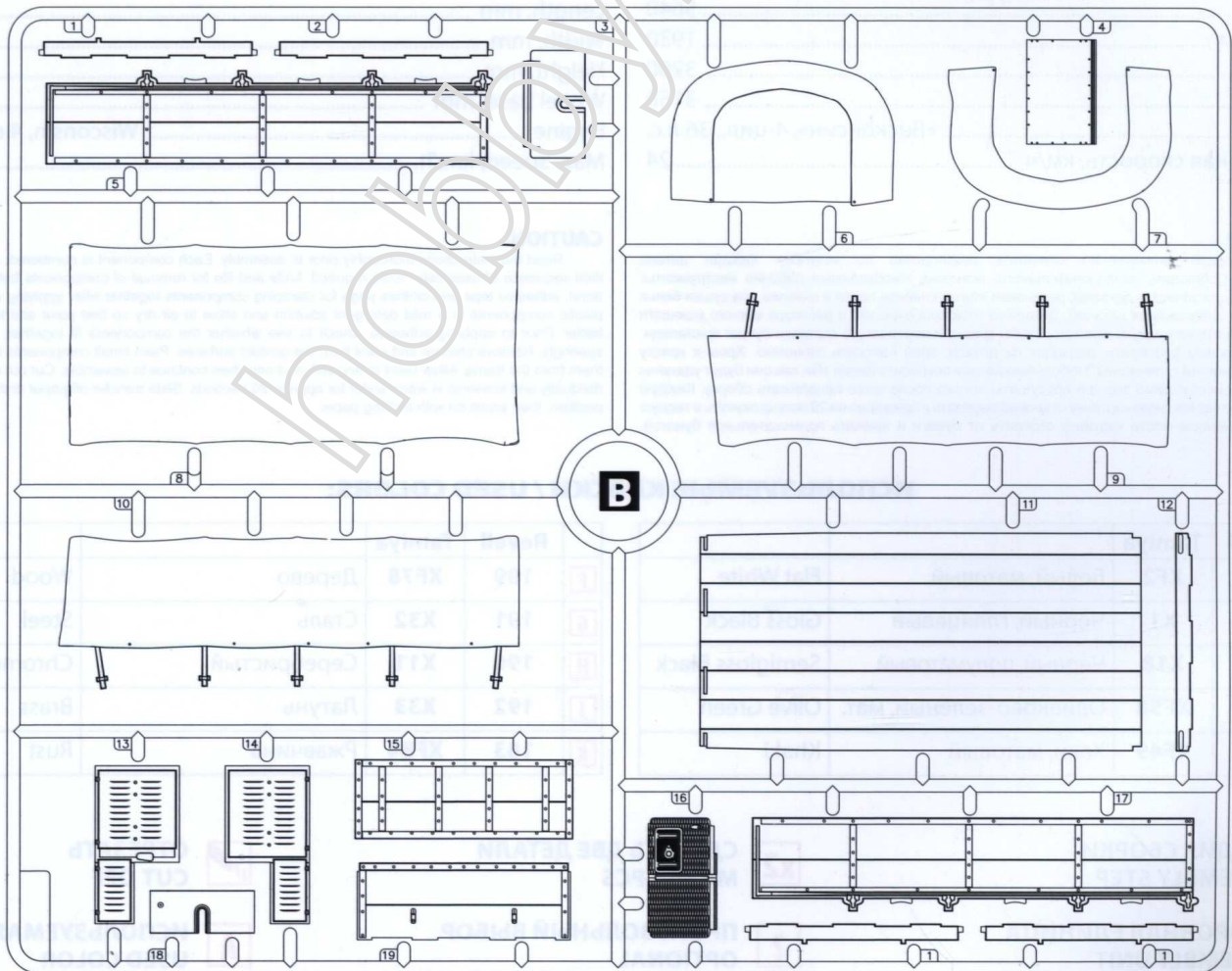
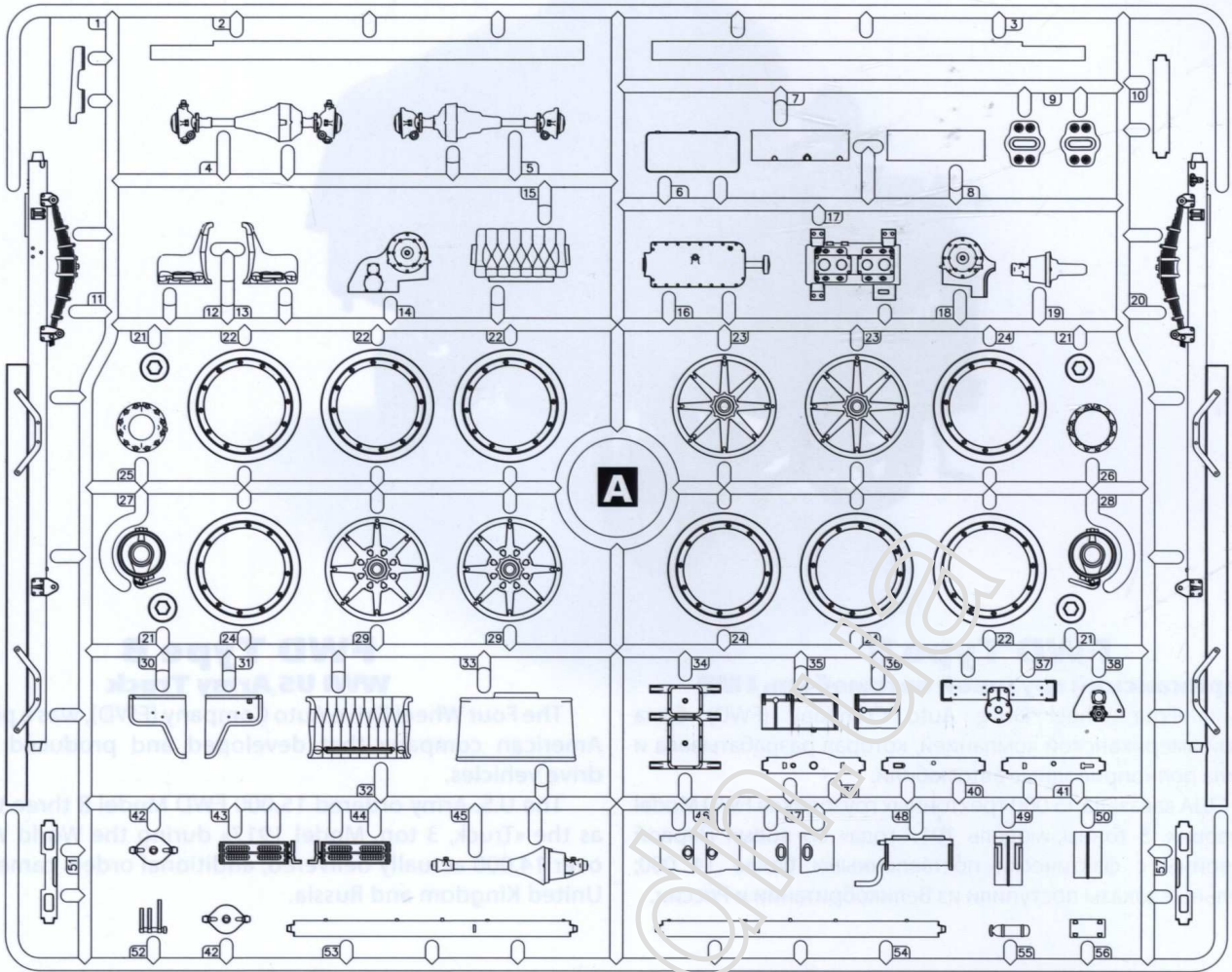

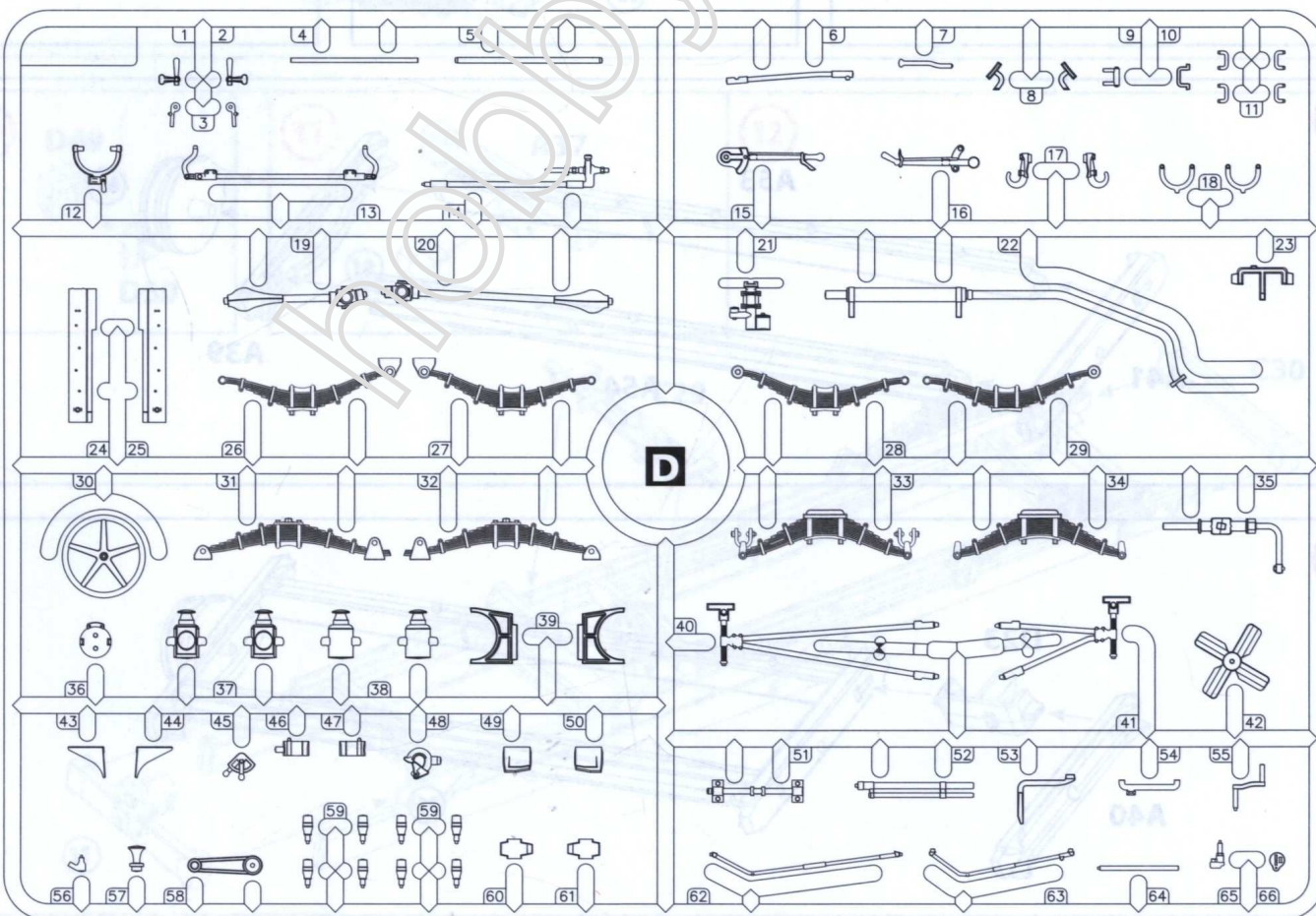
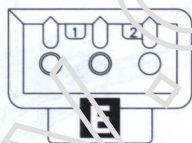
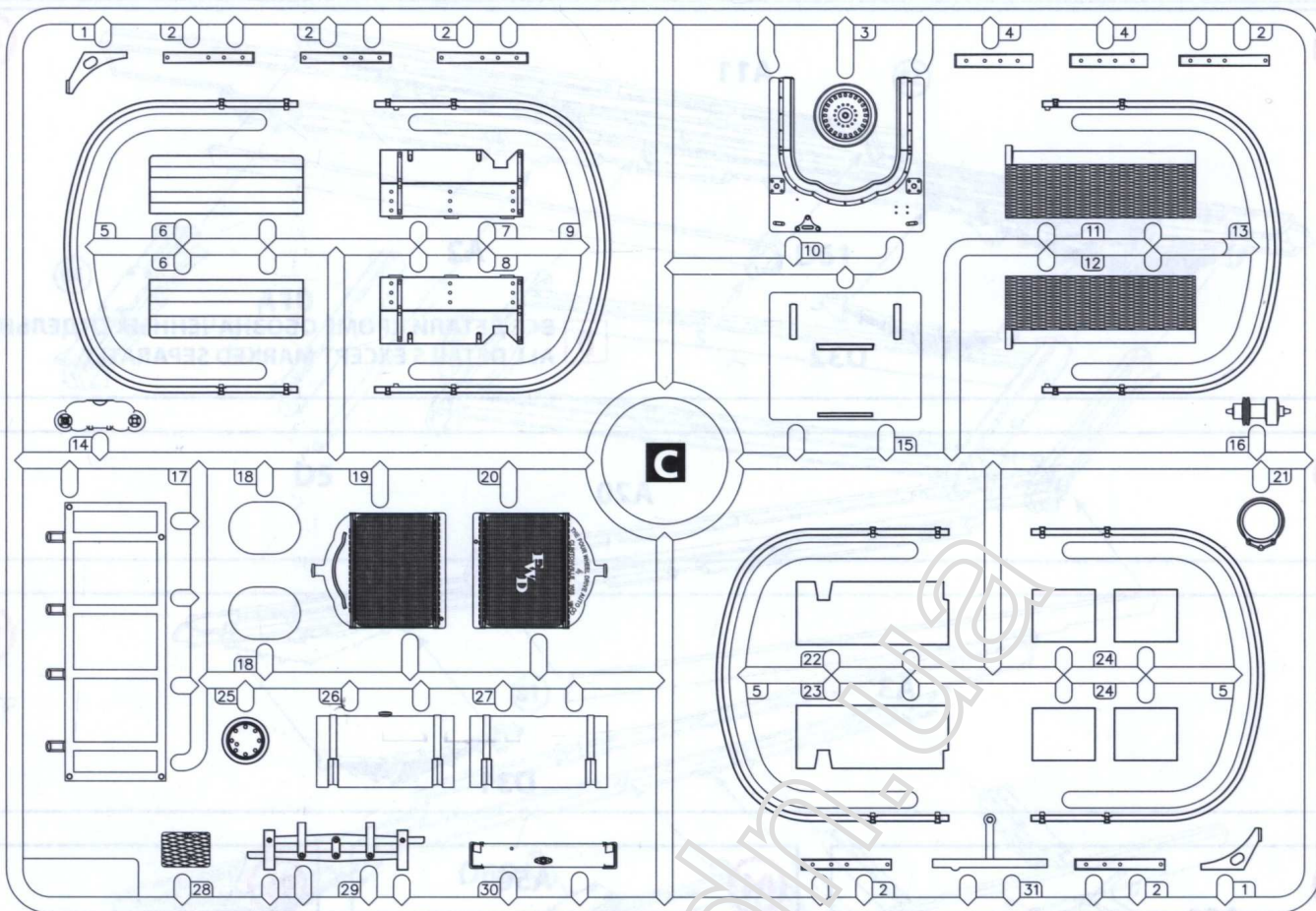

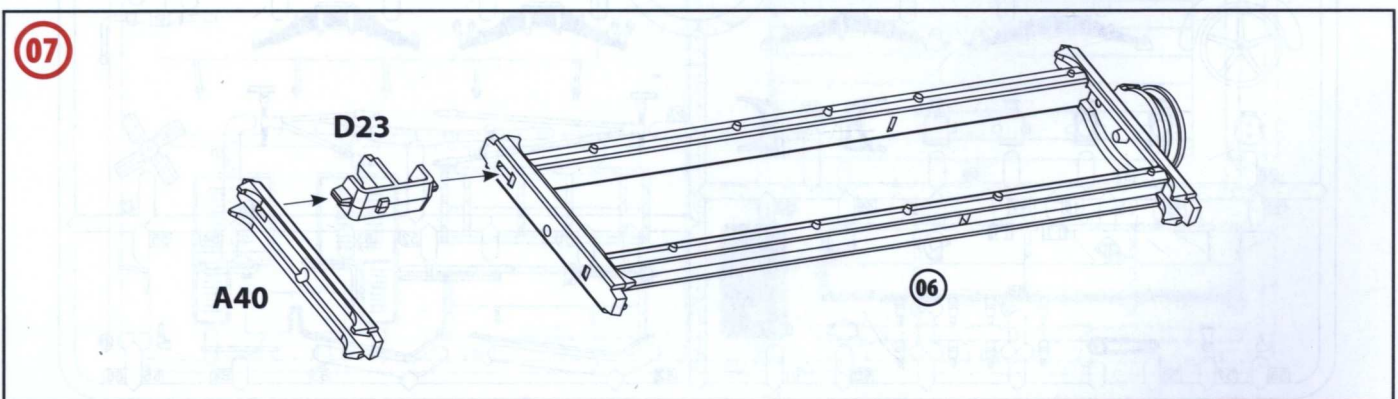
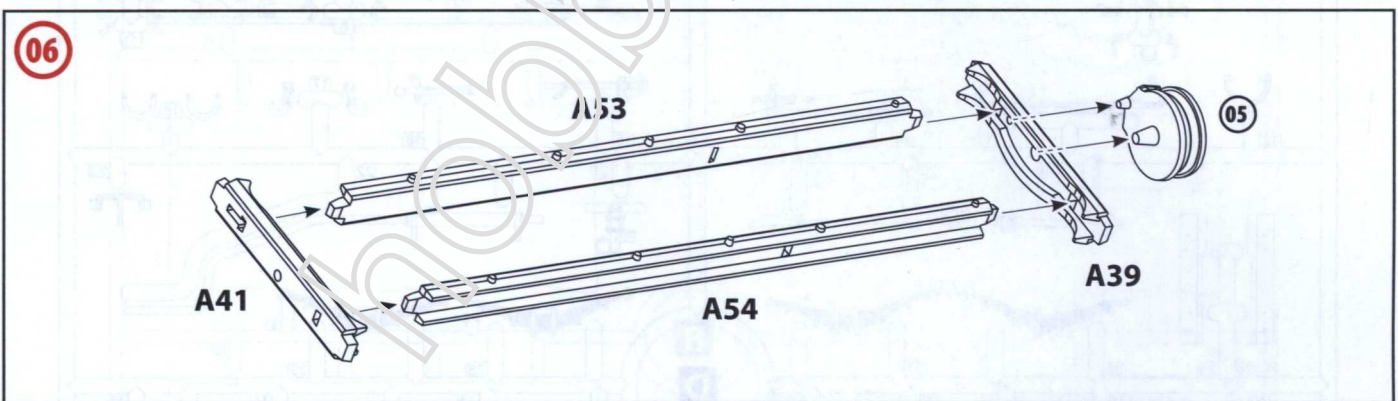
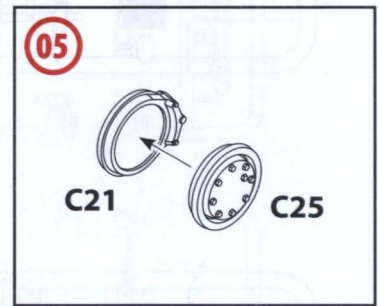
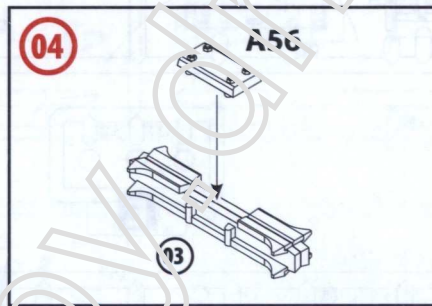
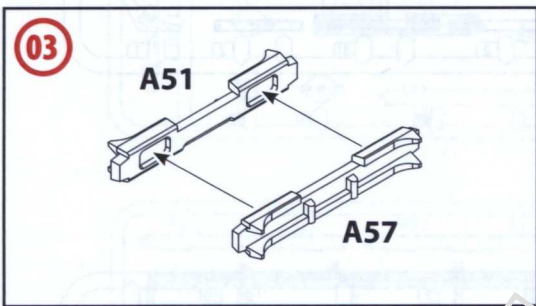
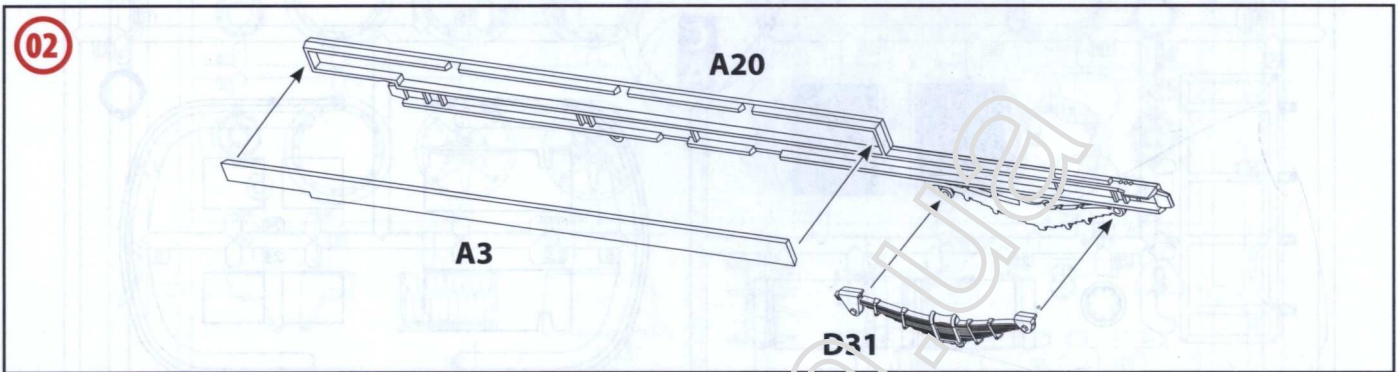
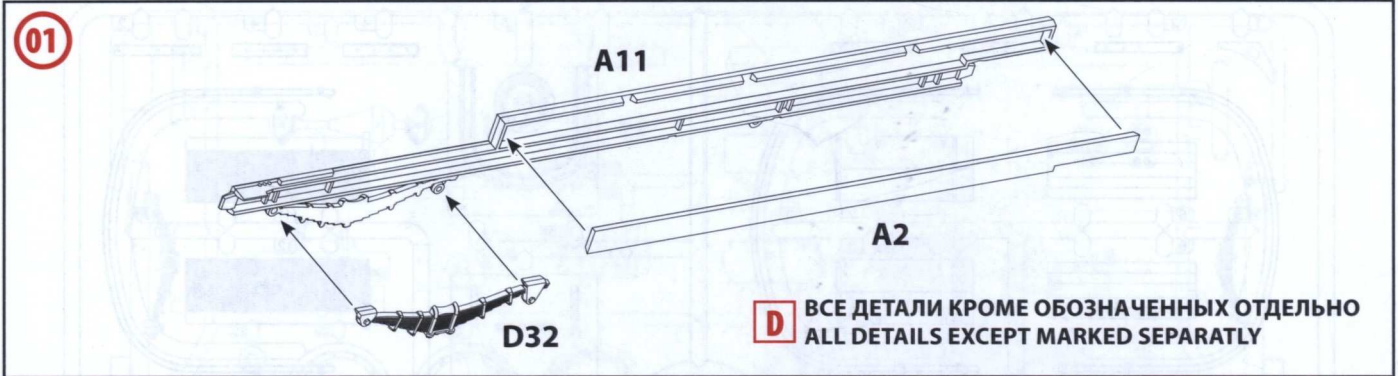

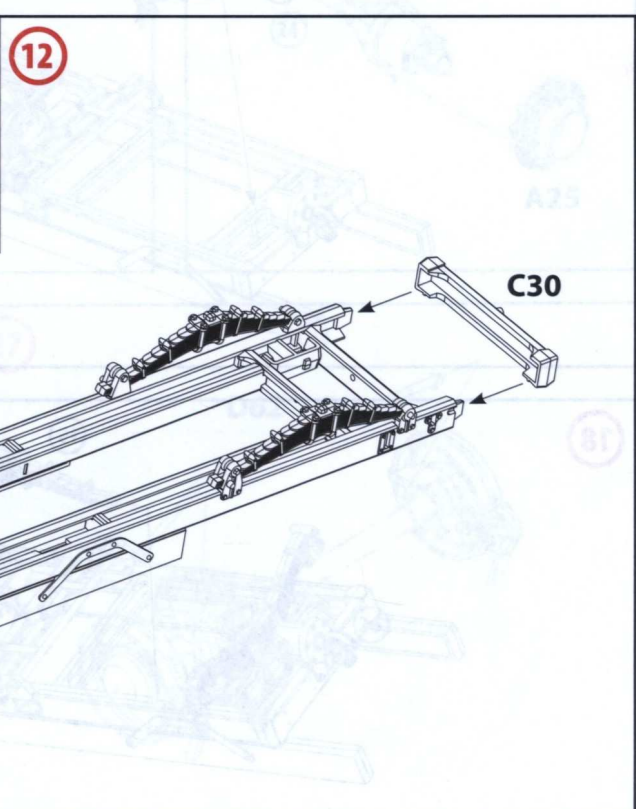
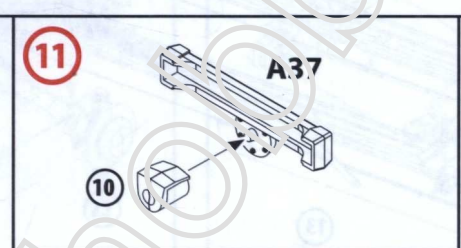
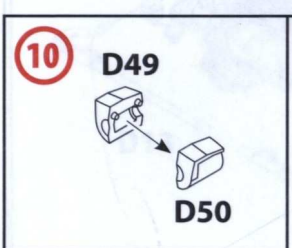
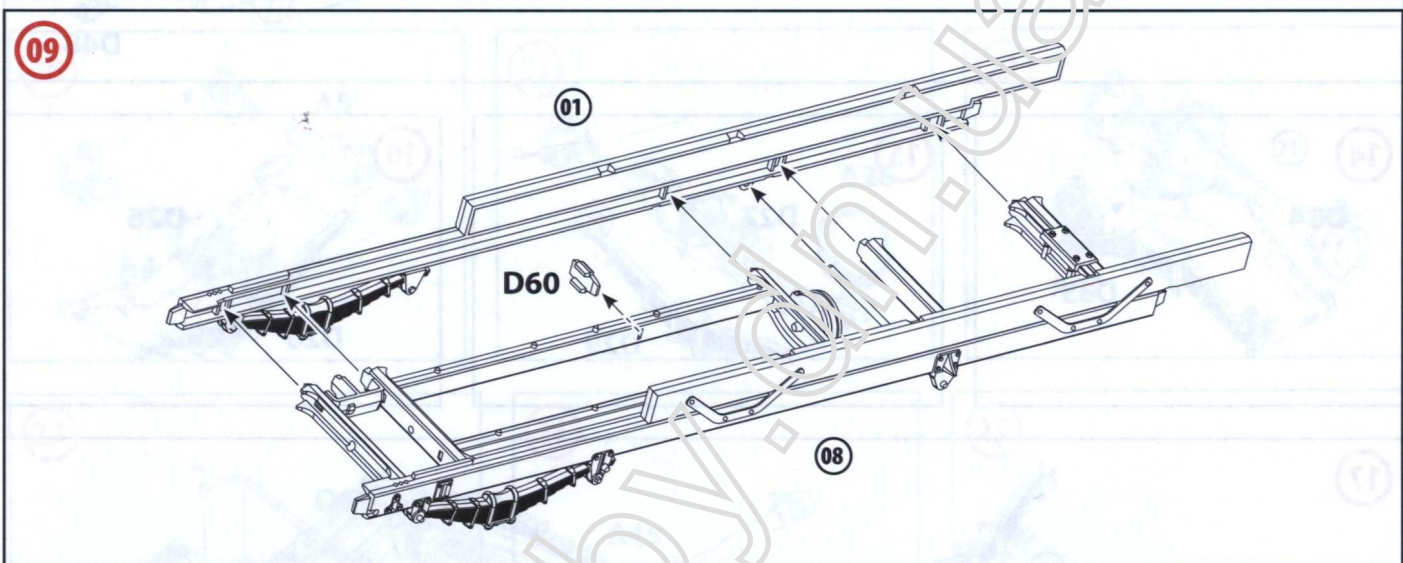
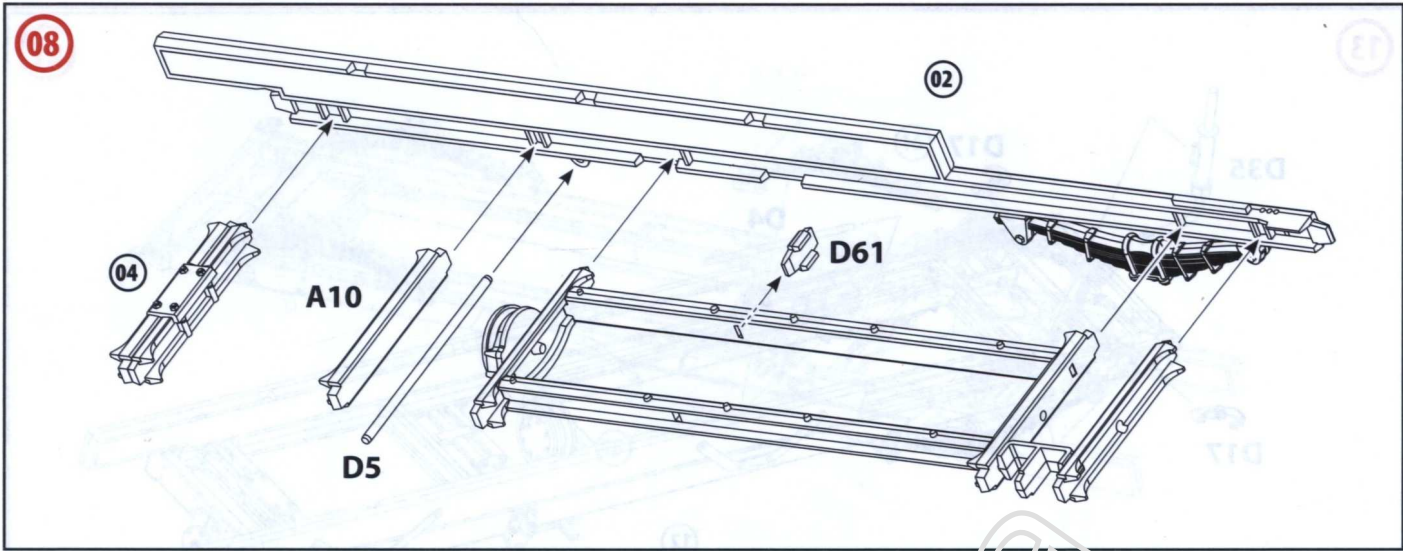

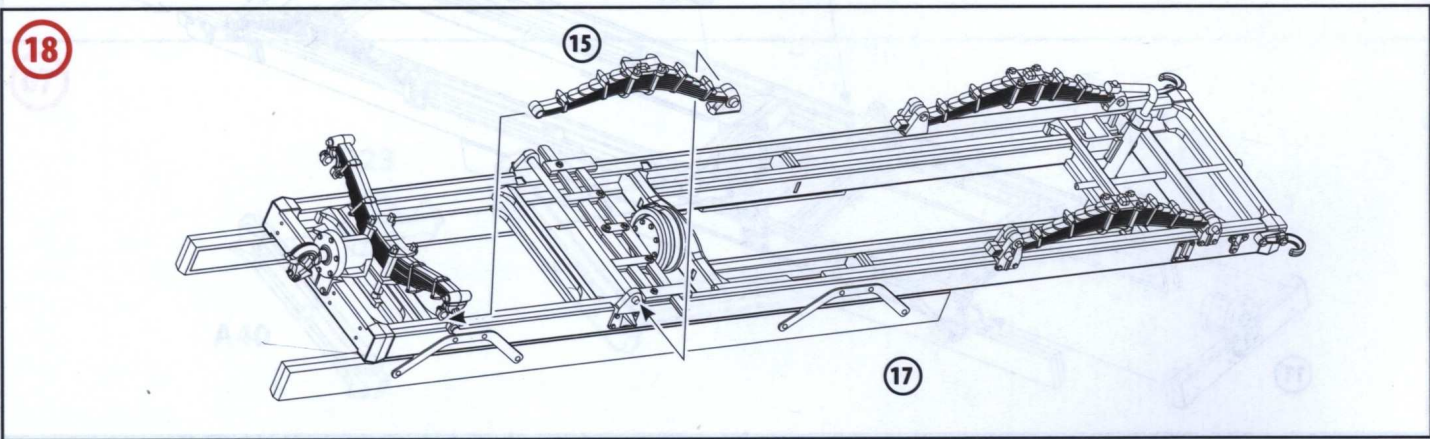
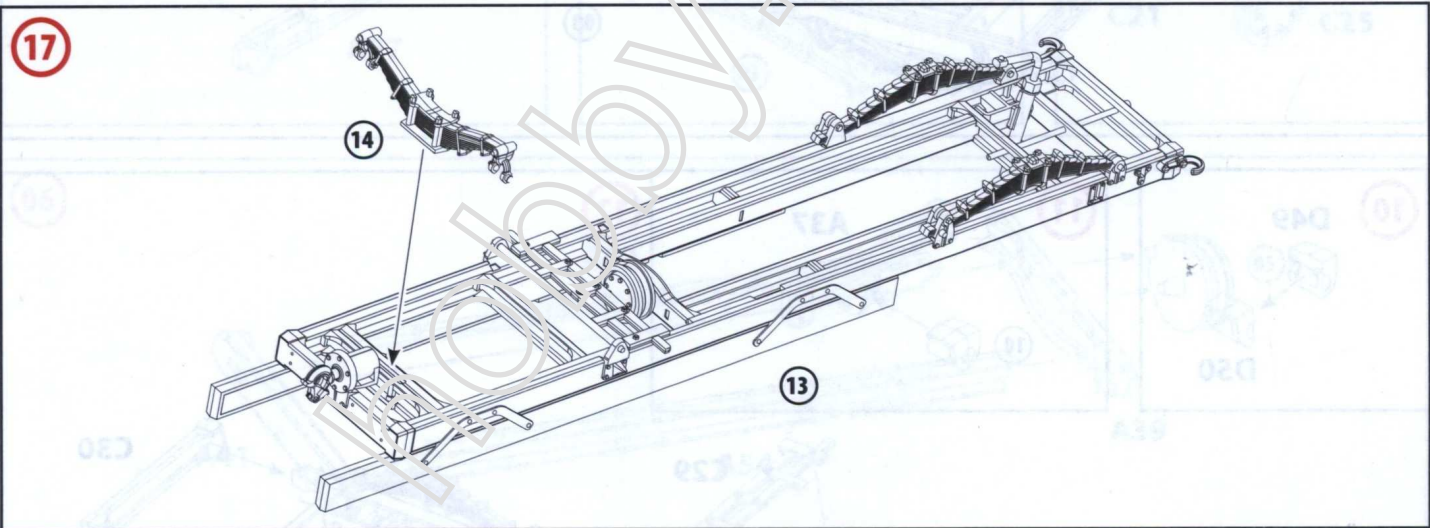
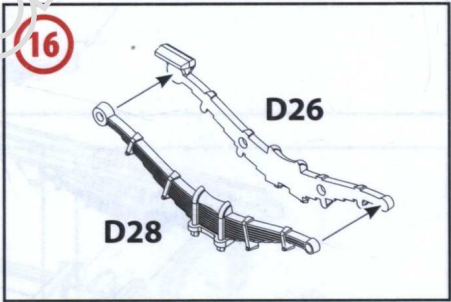
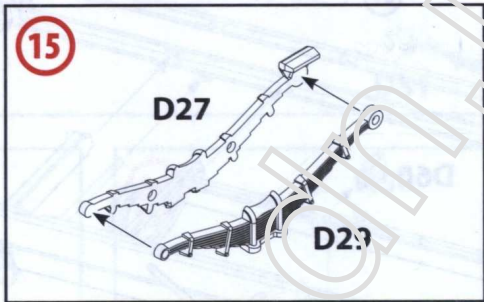
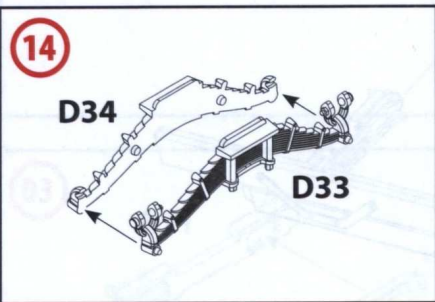
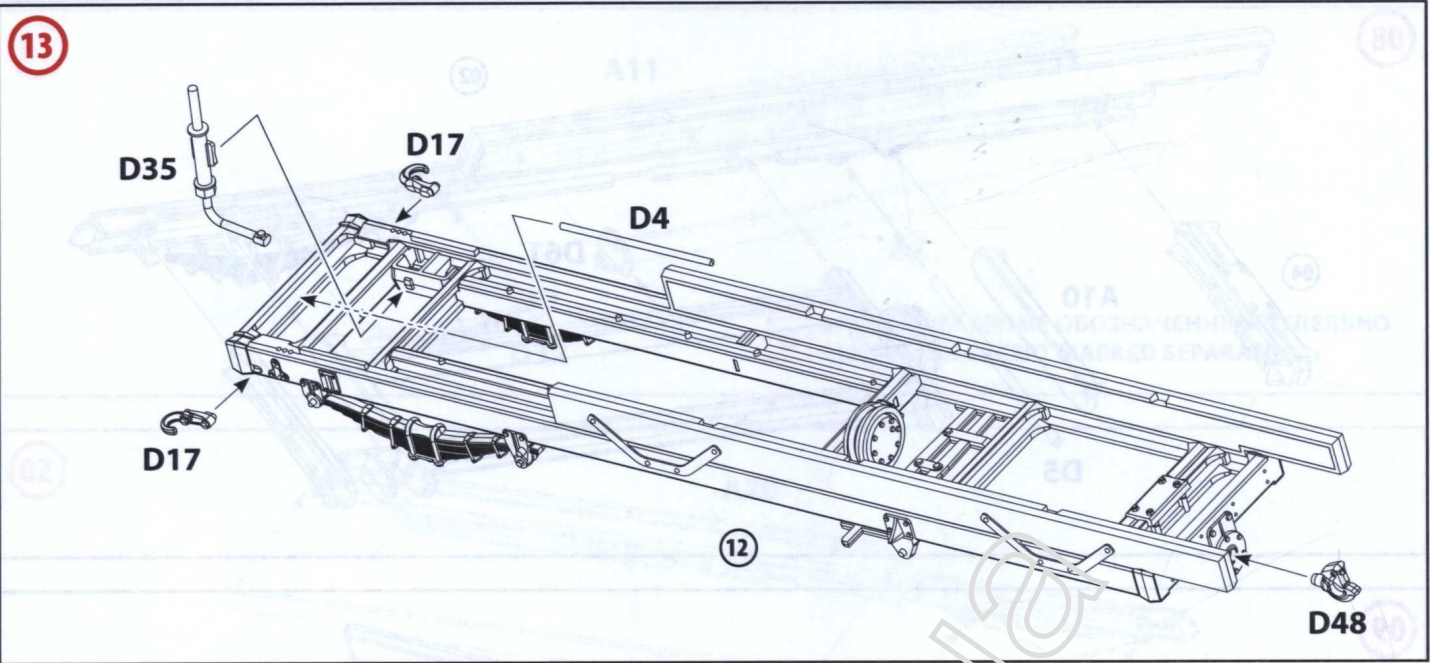

19

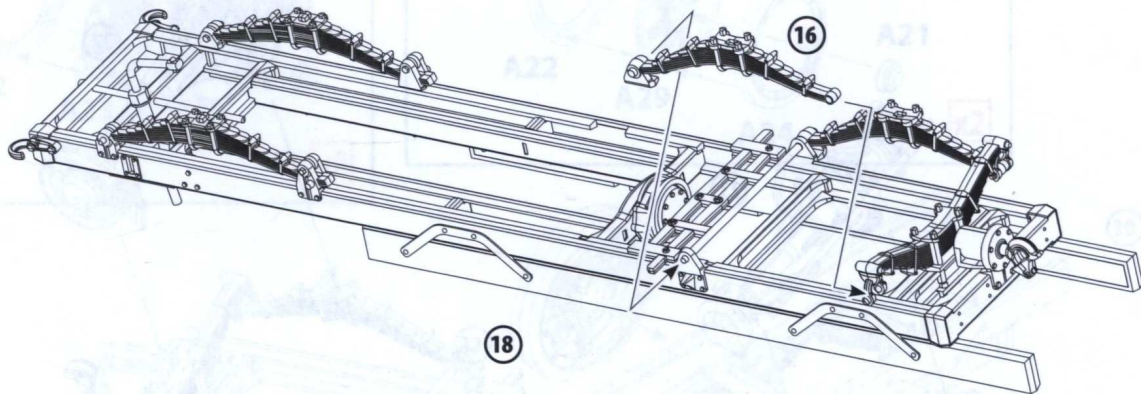

20

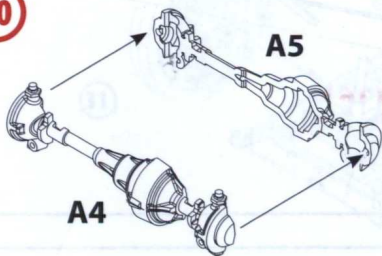

21

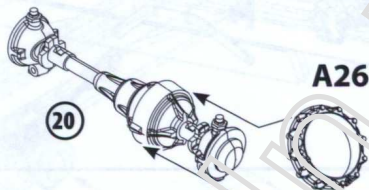

22

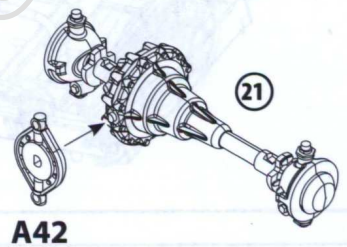

23

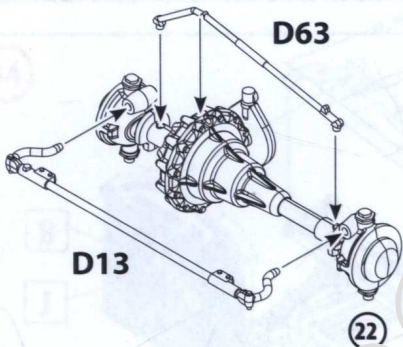

24

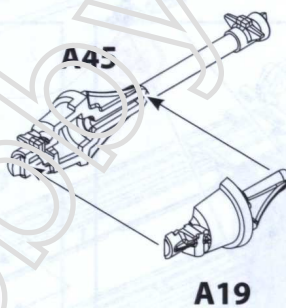

25

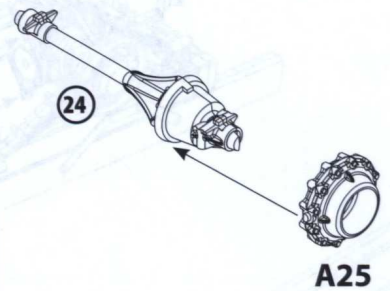

26

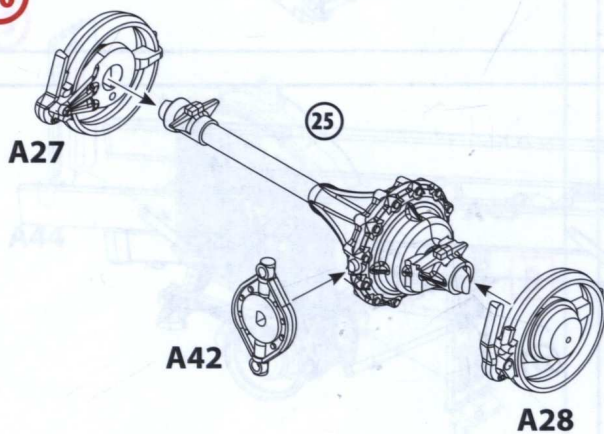

27

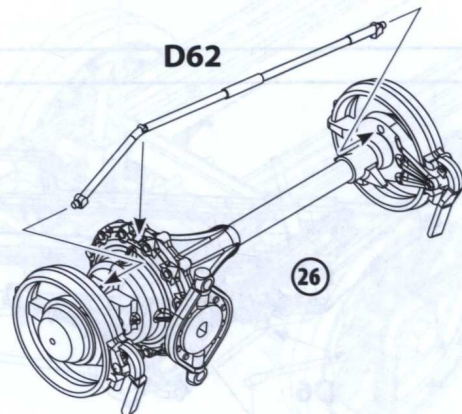

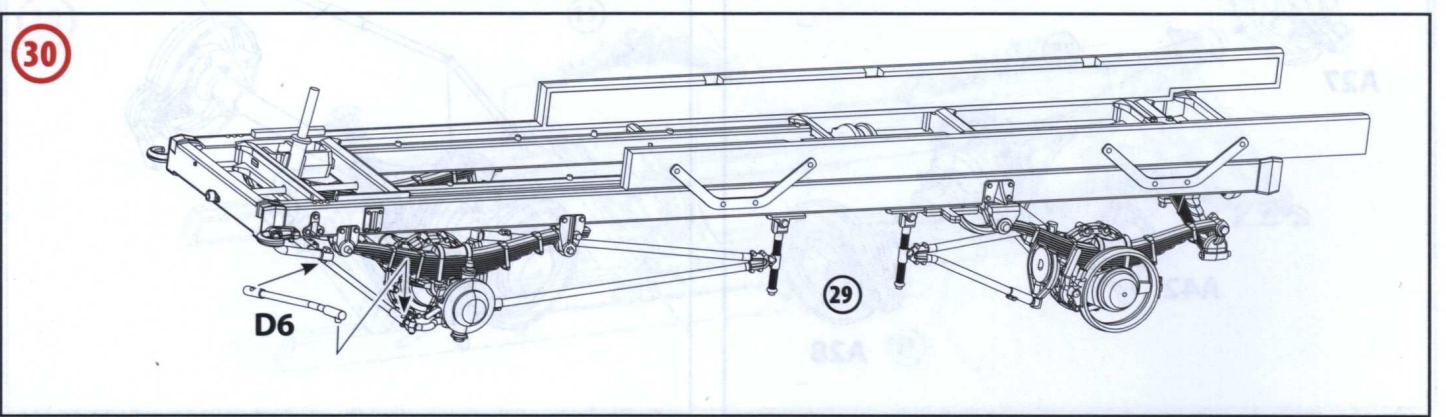
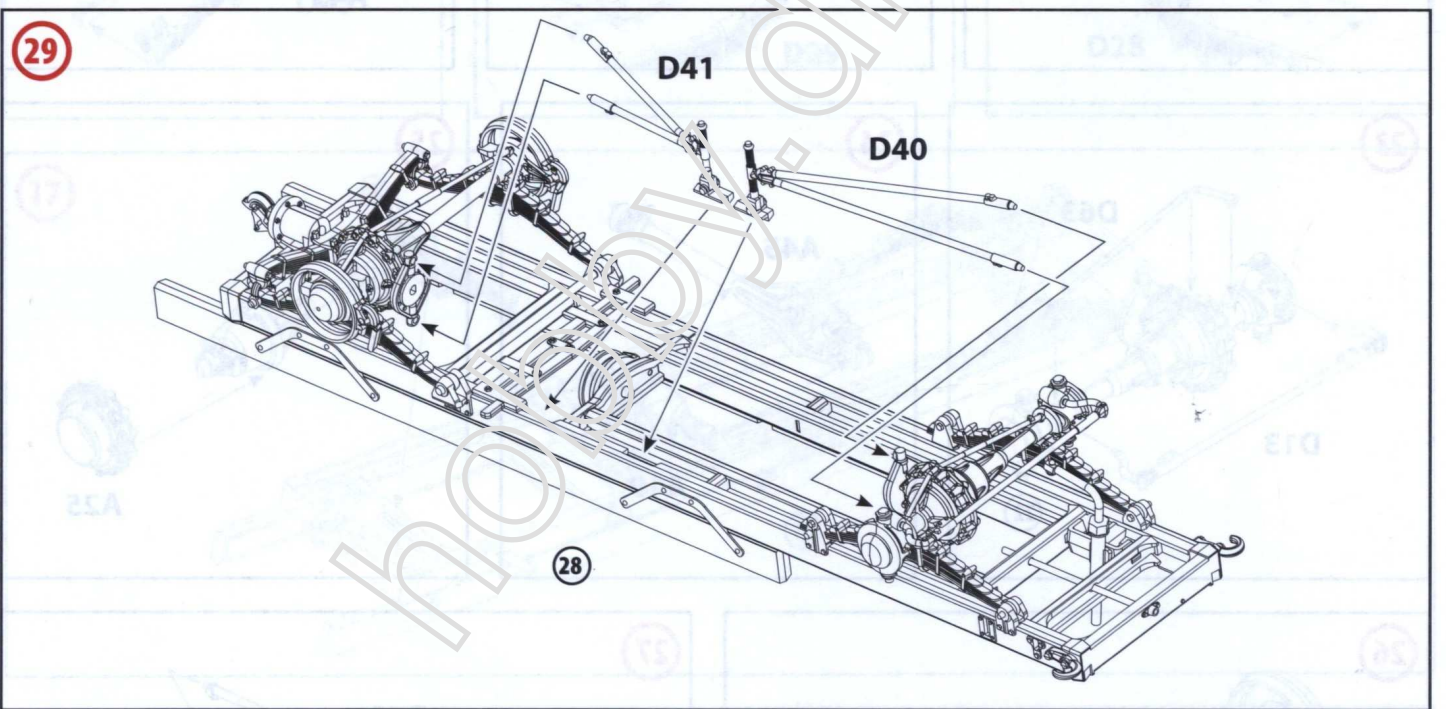
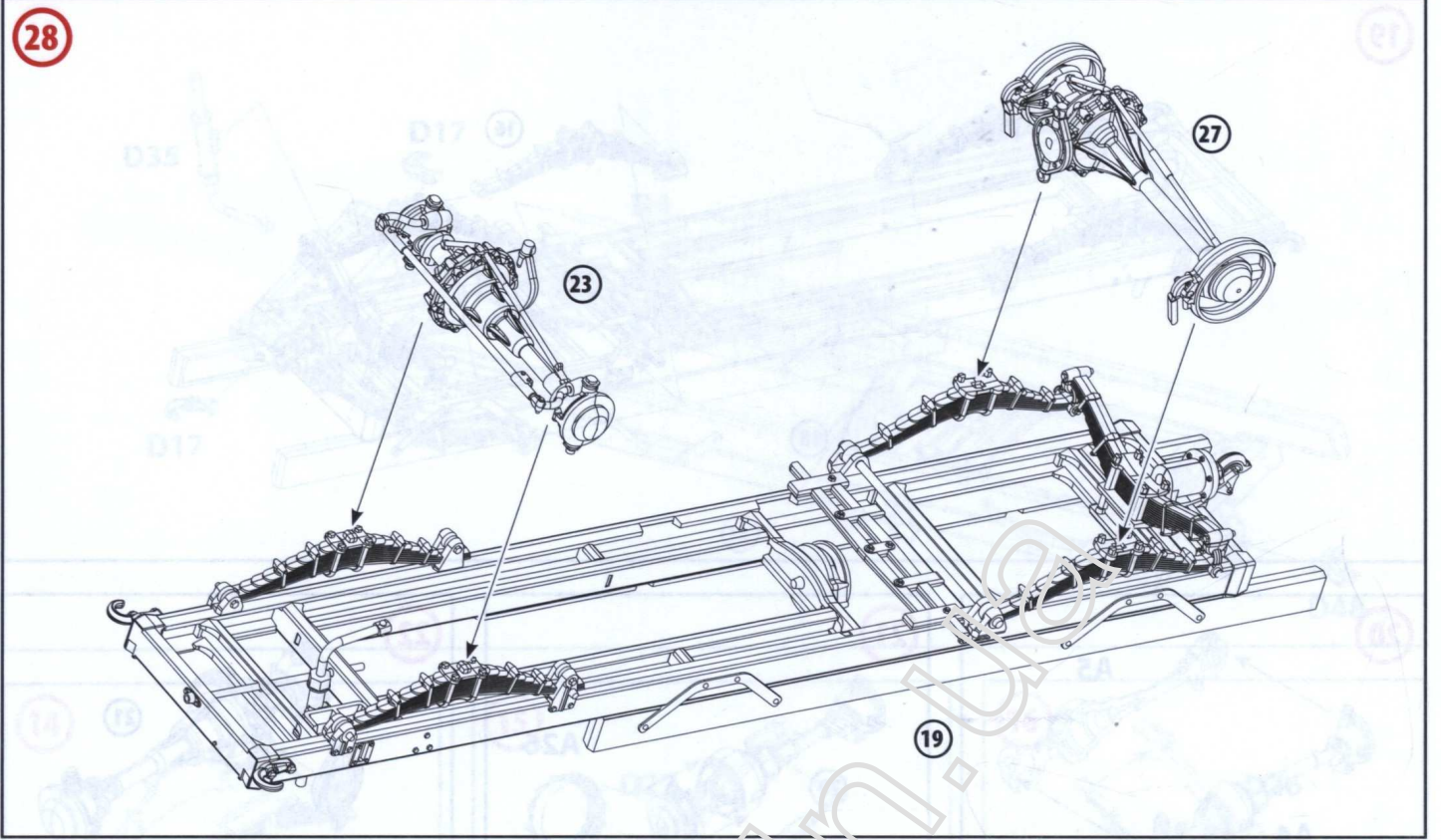

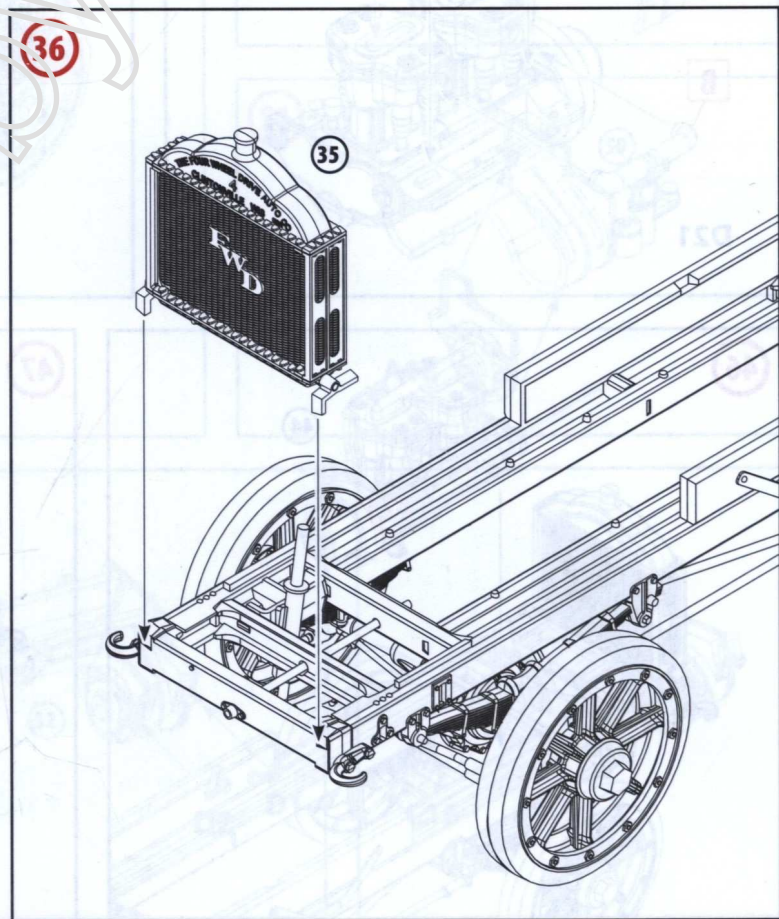
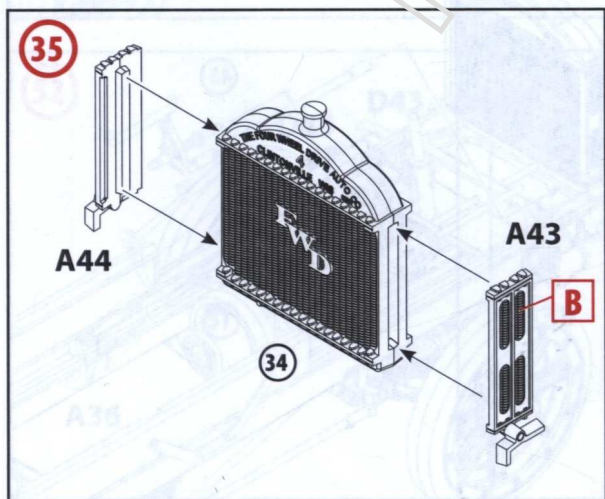
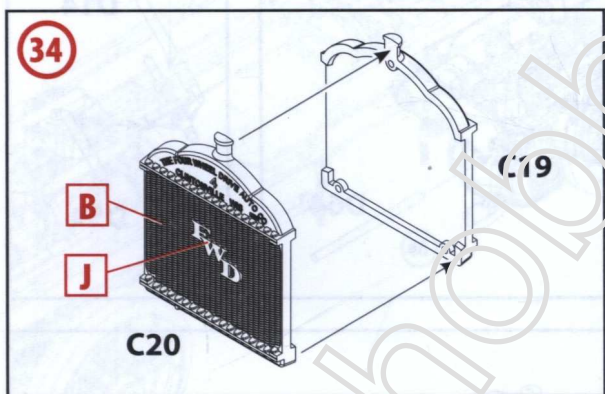
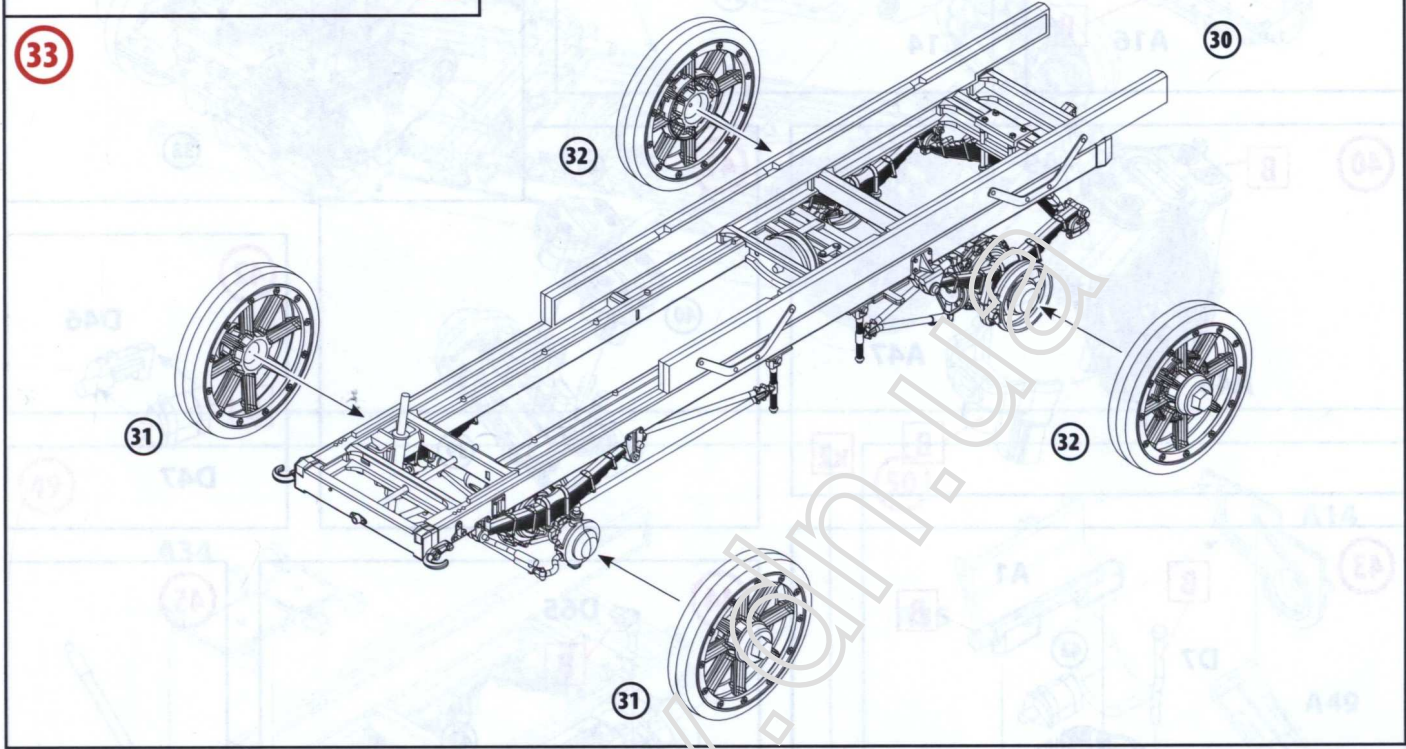
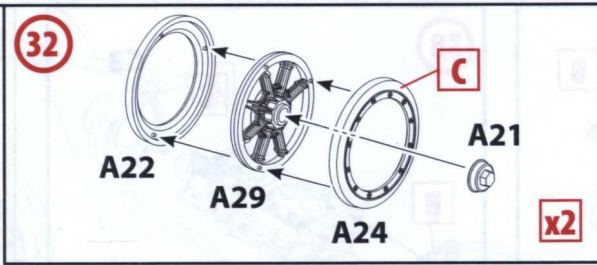
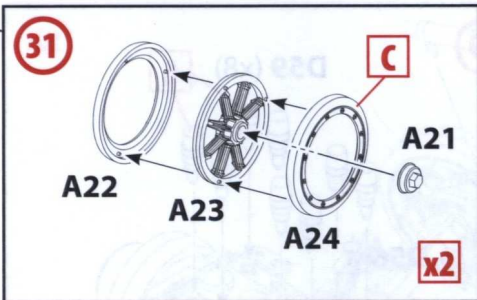

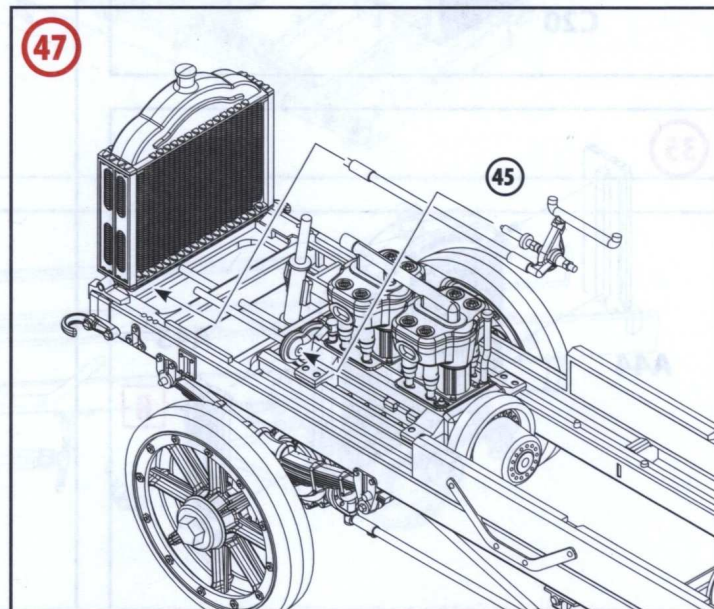
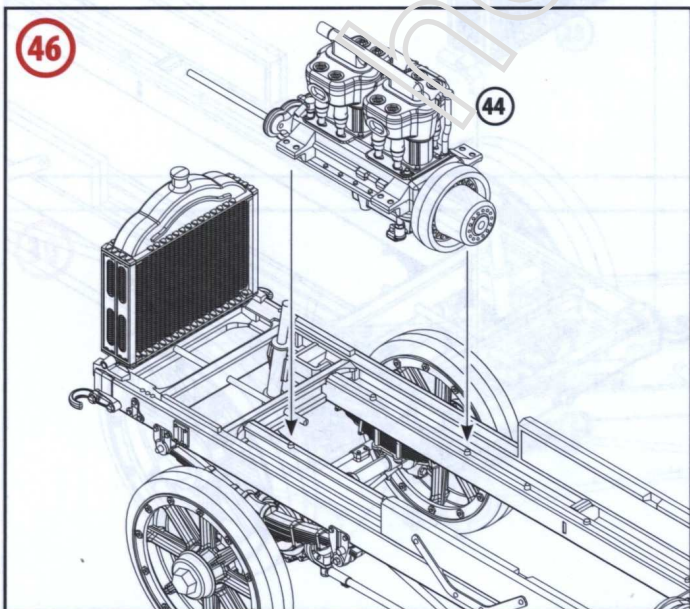
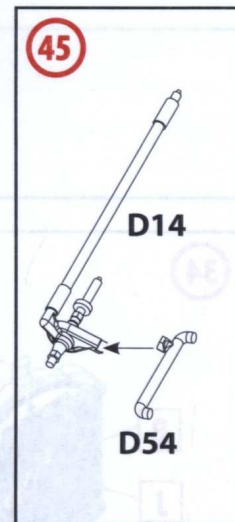
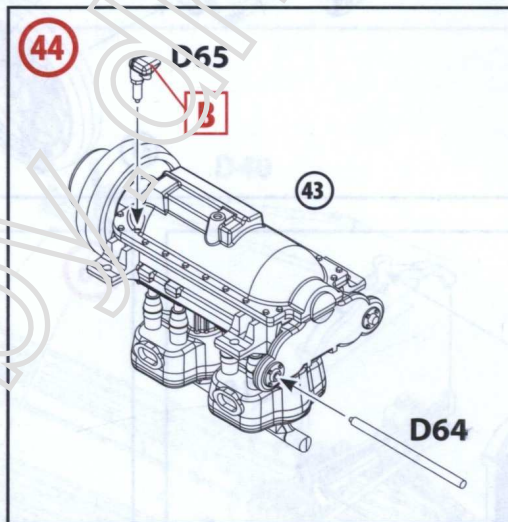
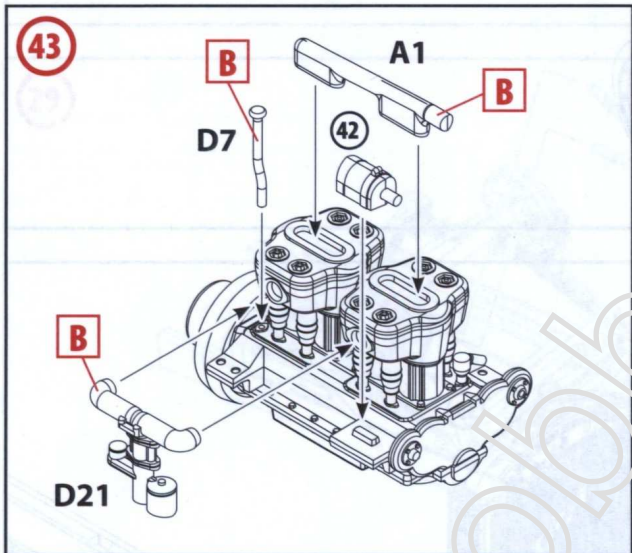
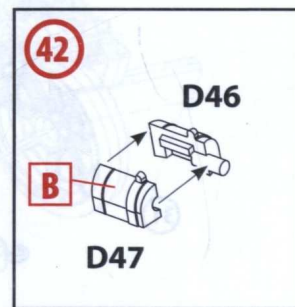
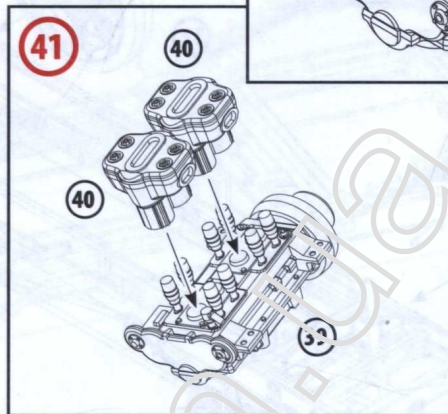
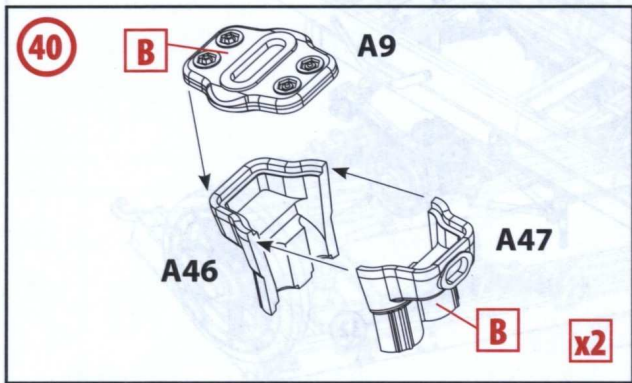
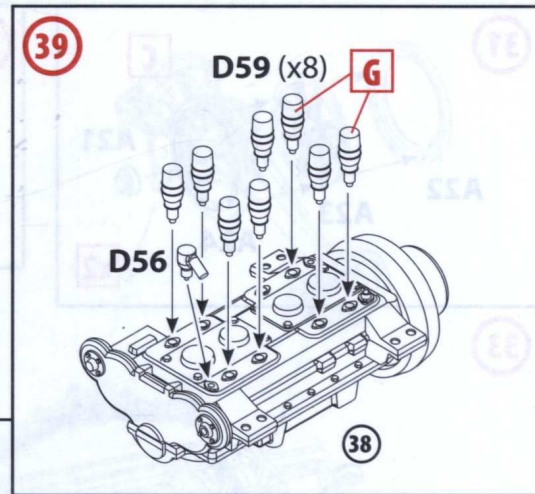
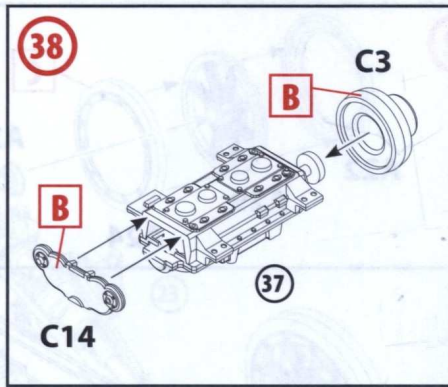
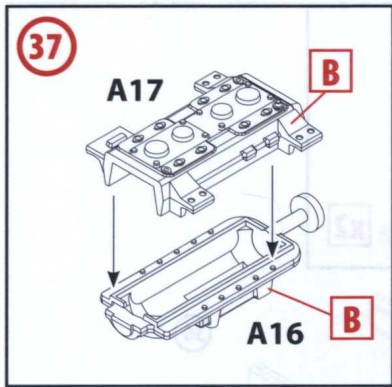

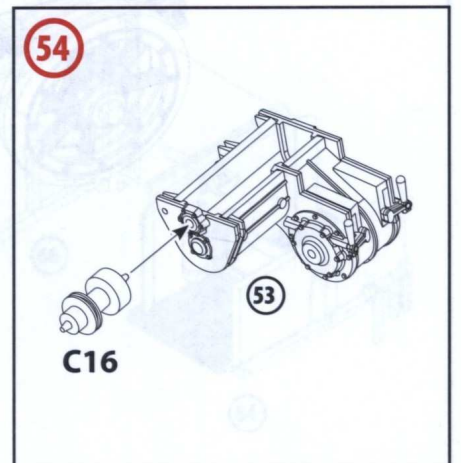
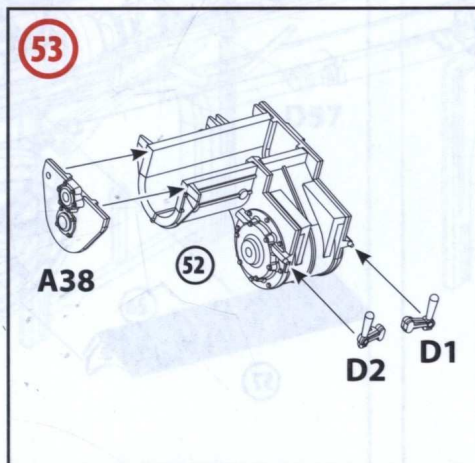
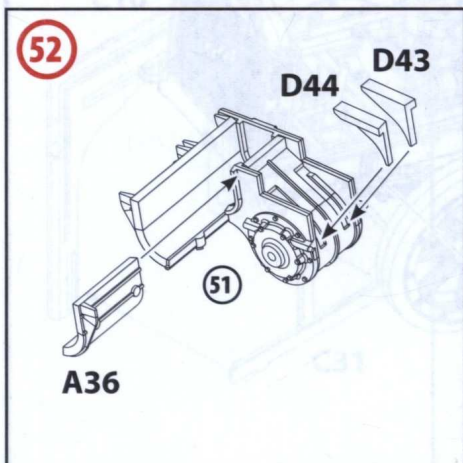
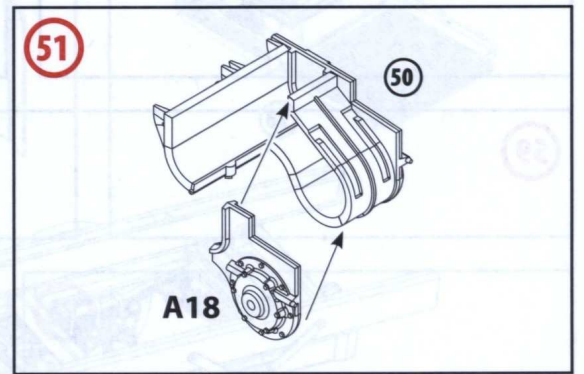
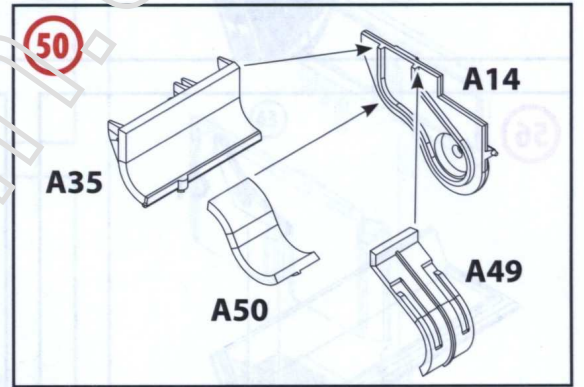
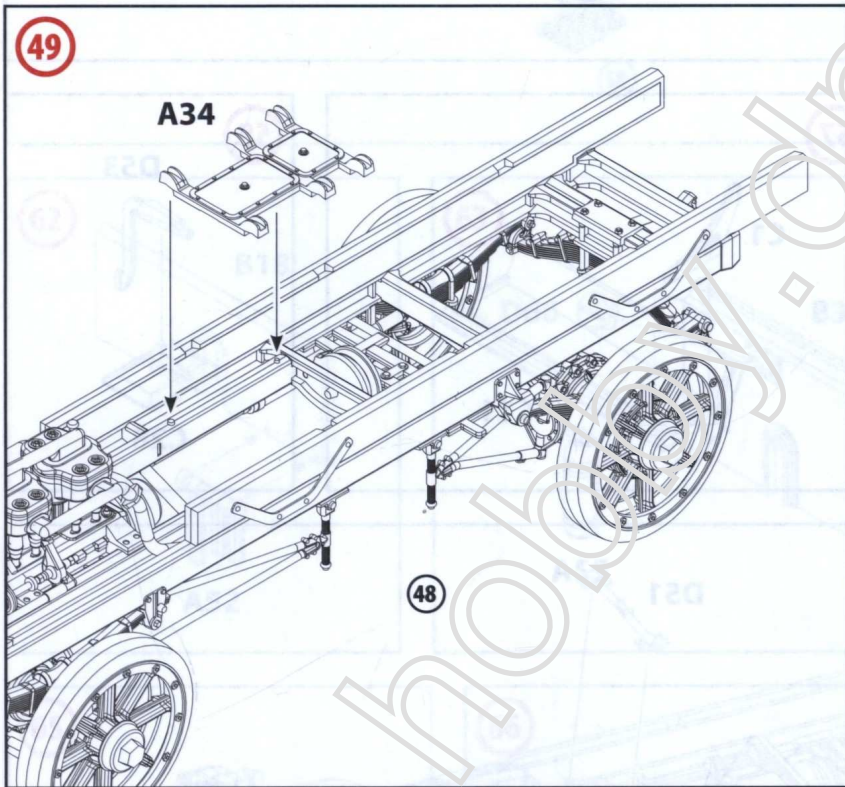
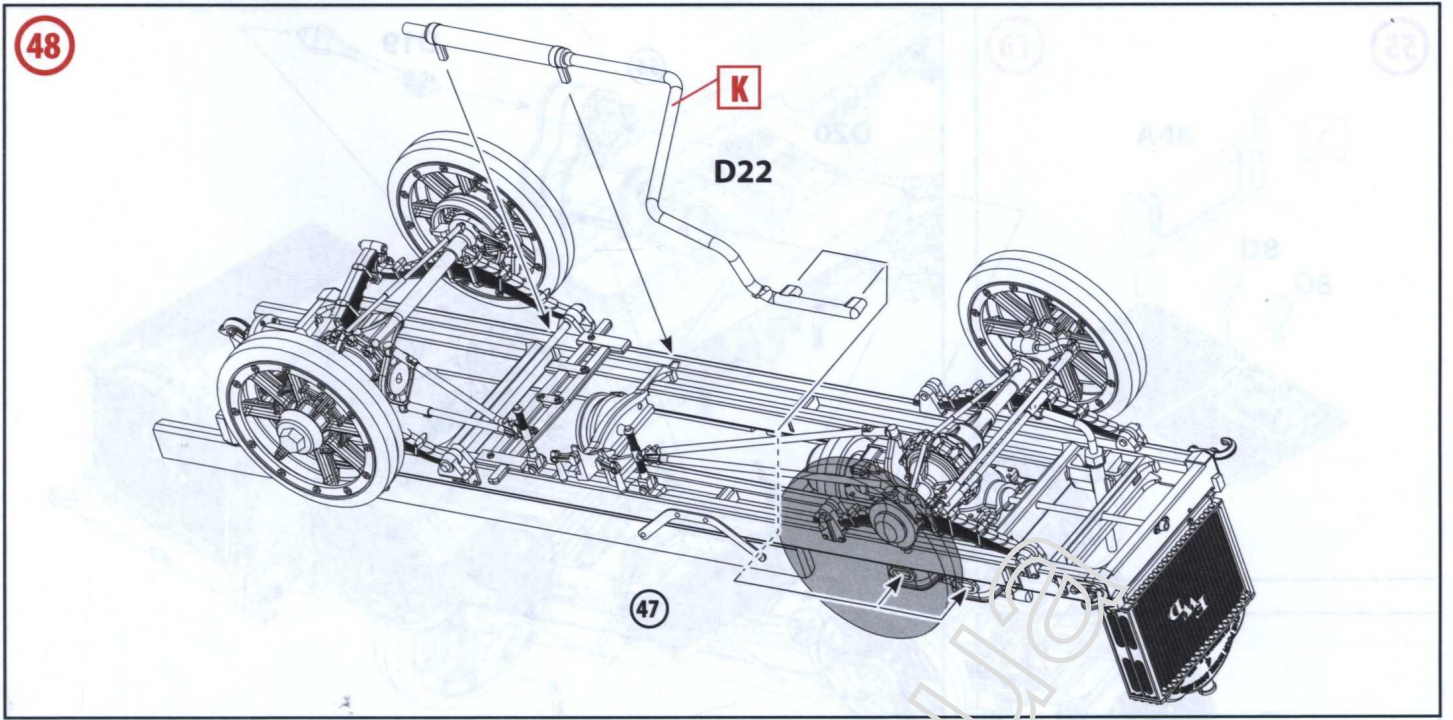

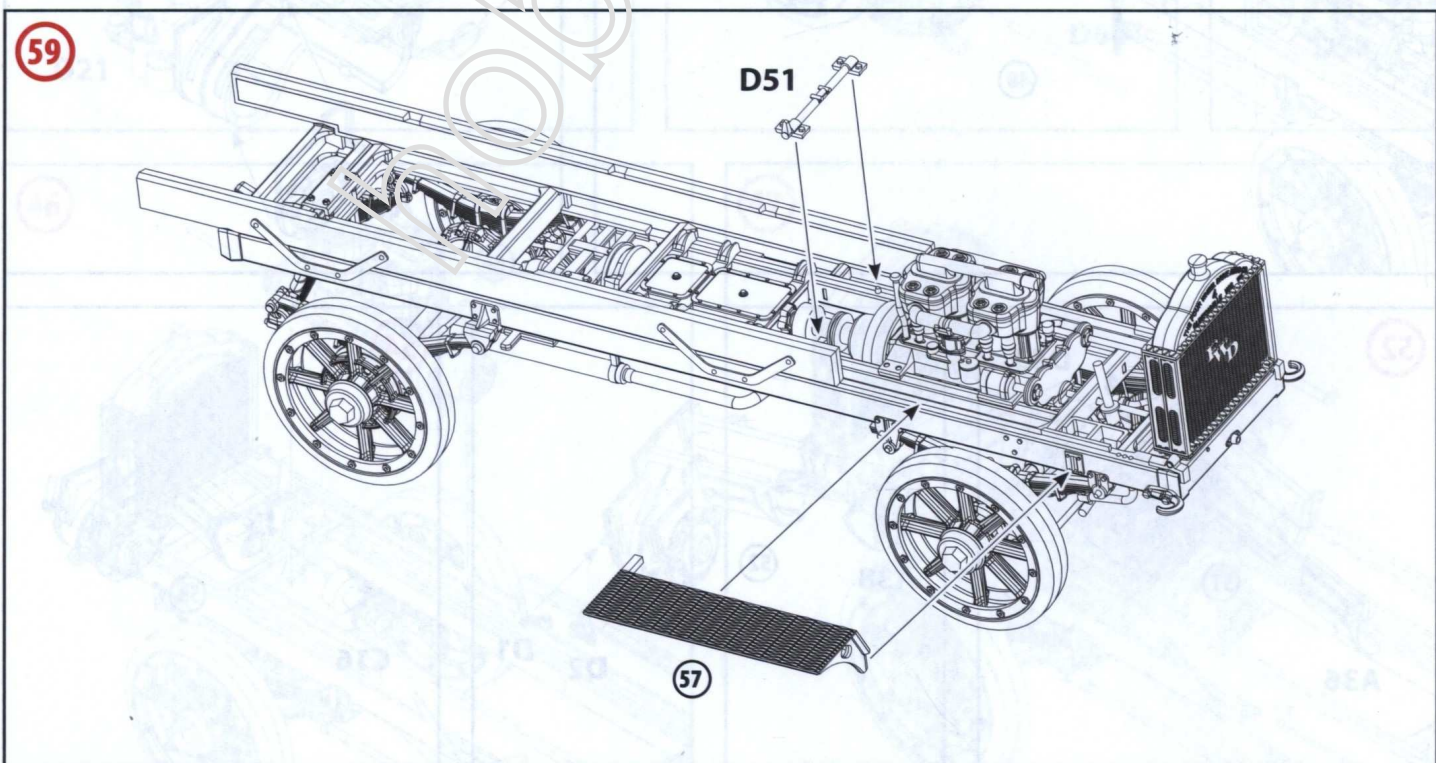
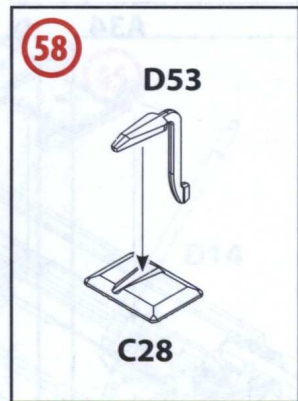
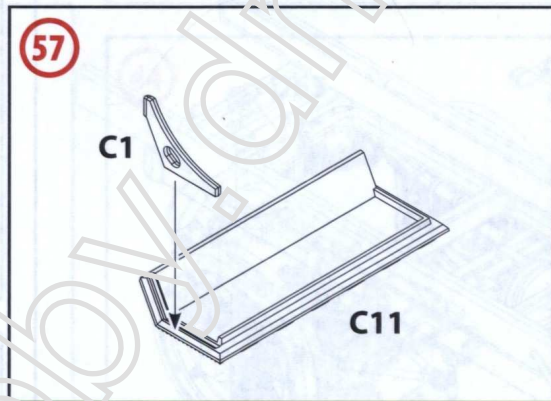
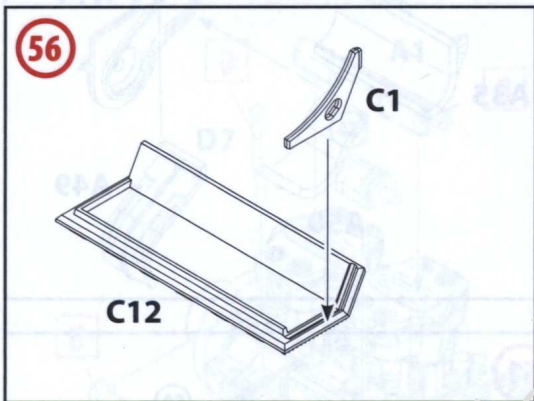
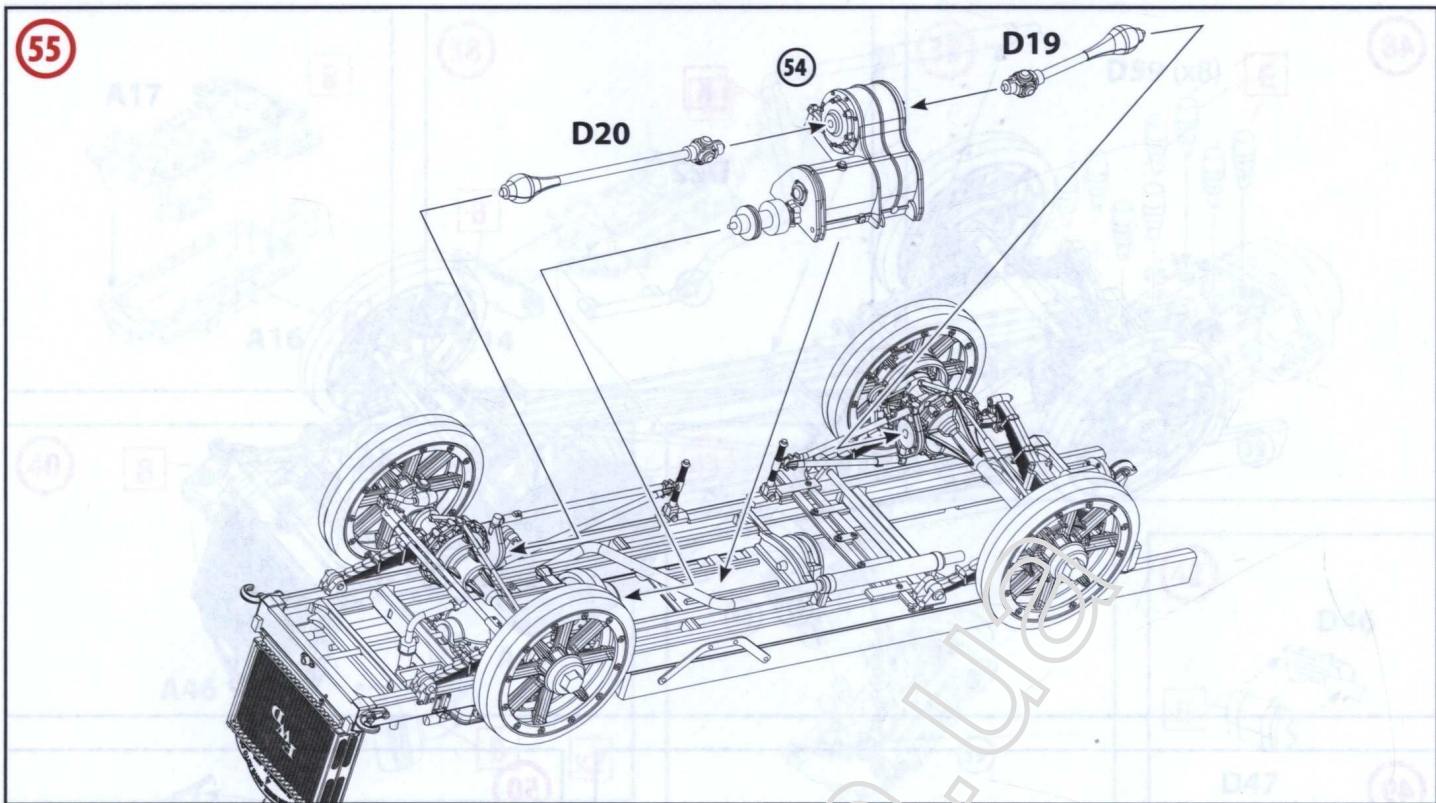

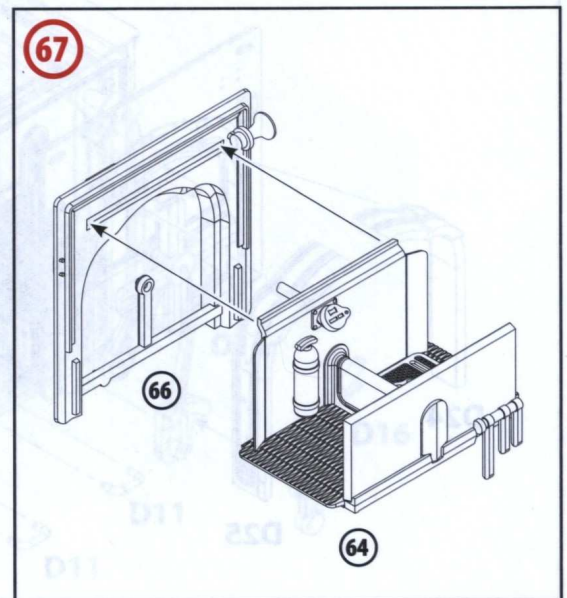
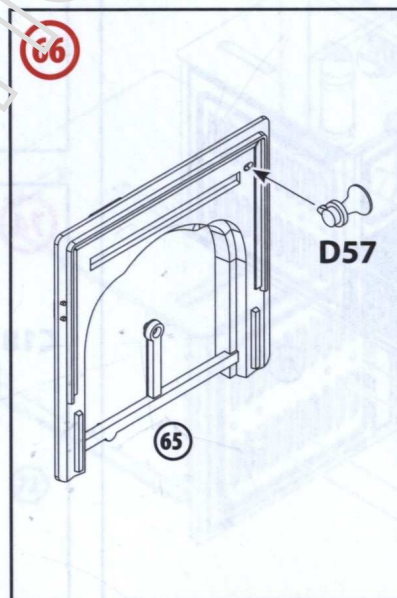
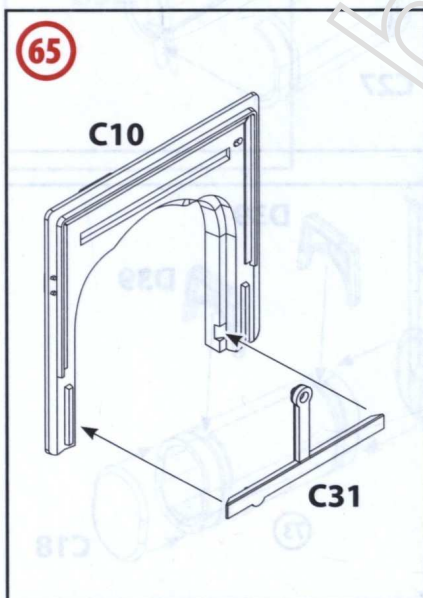
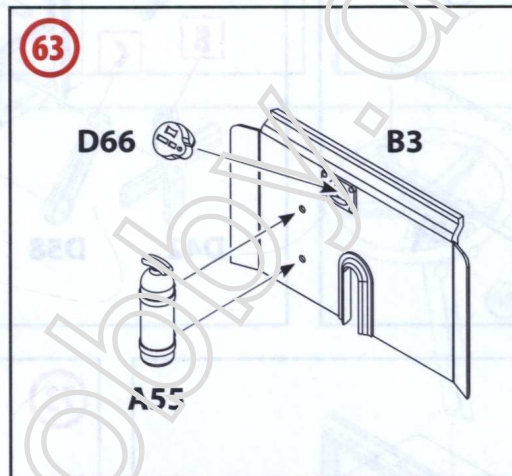
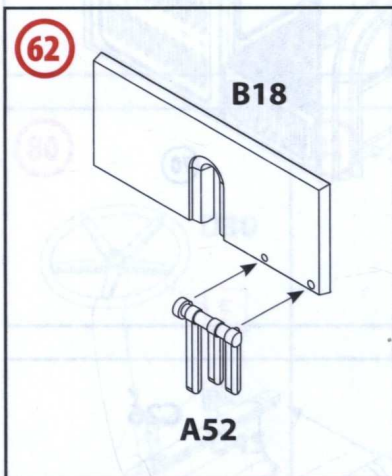
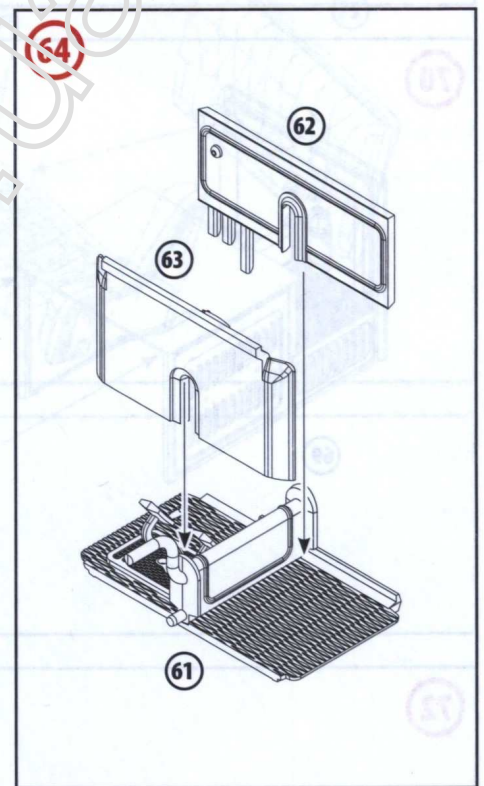
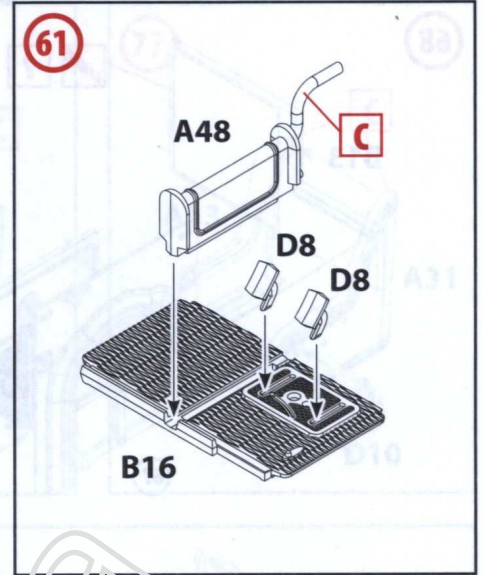
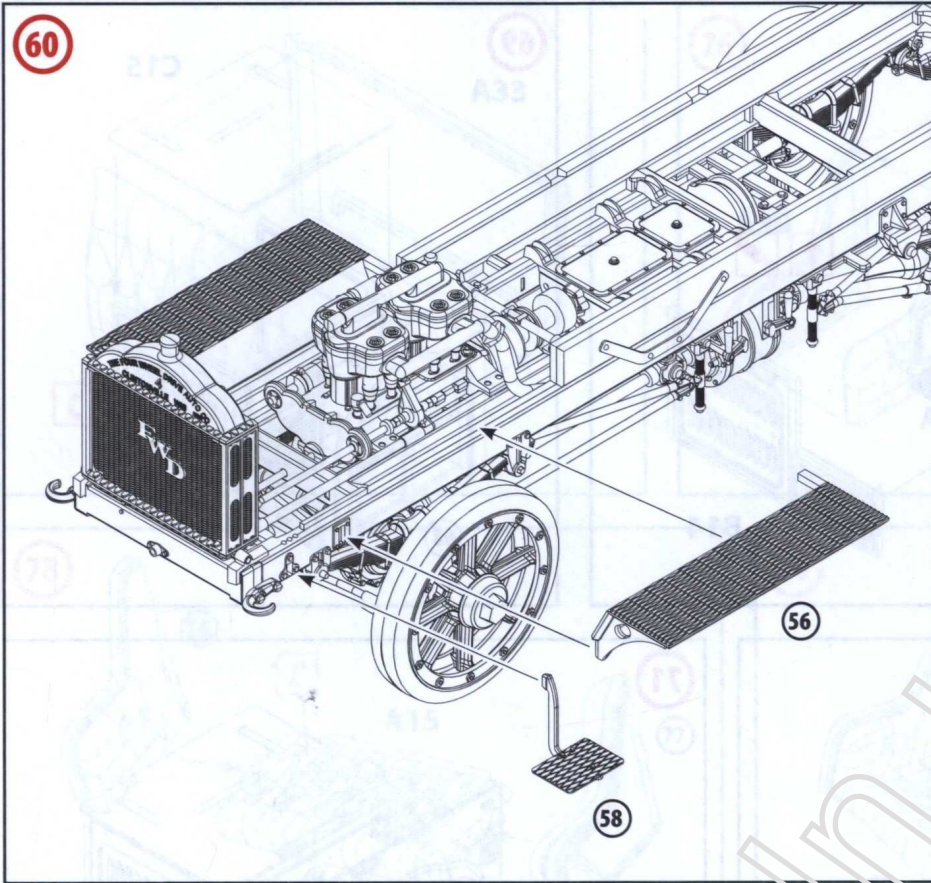

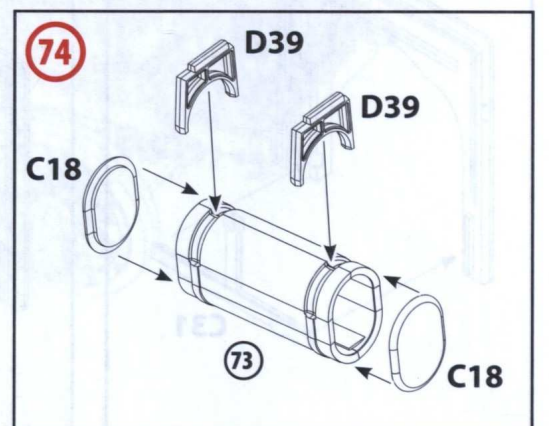
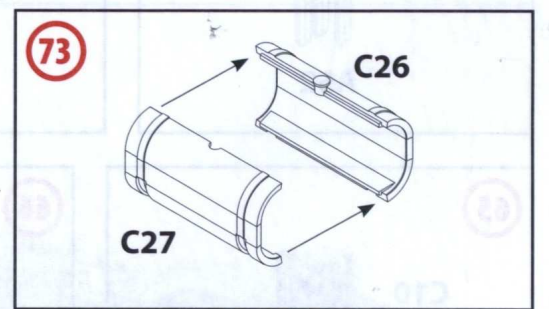
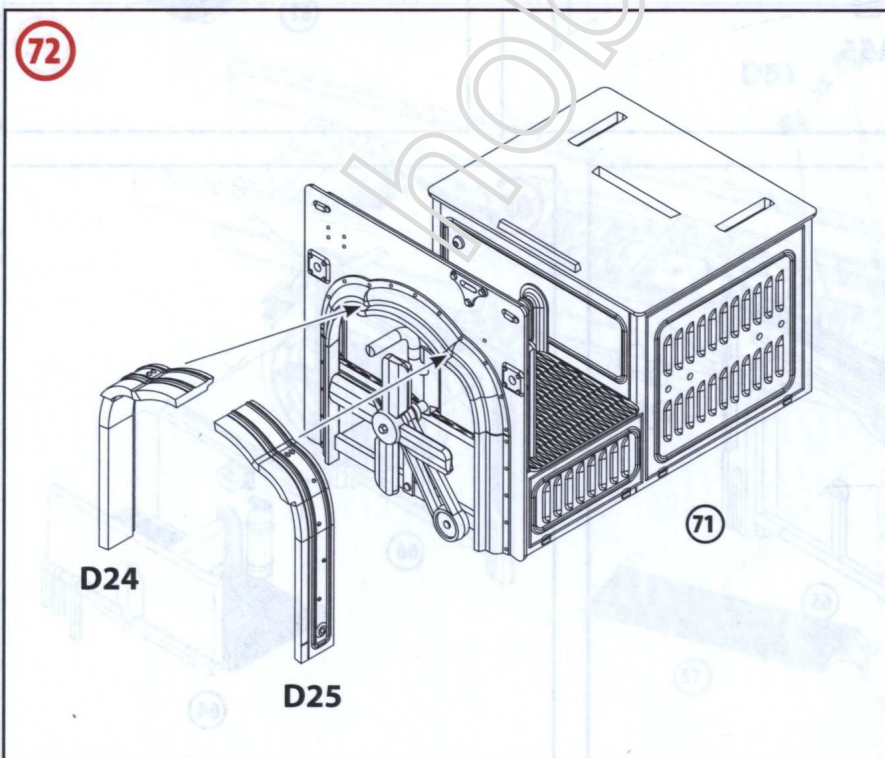
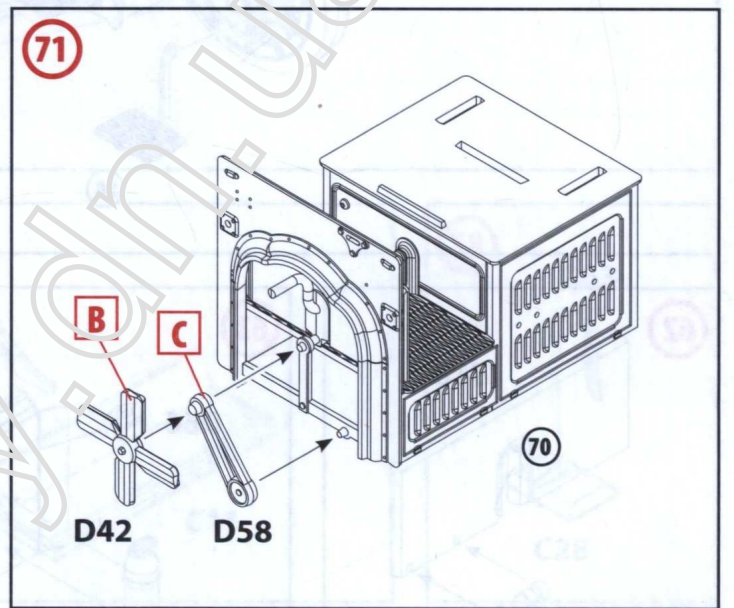
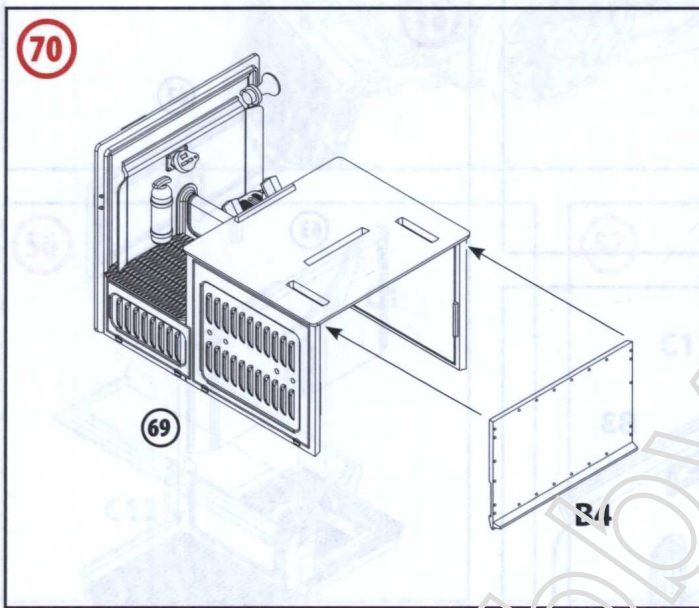
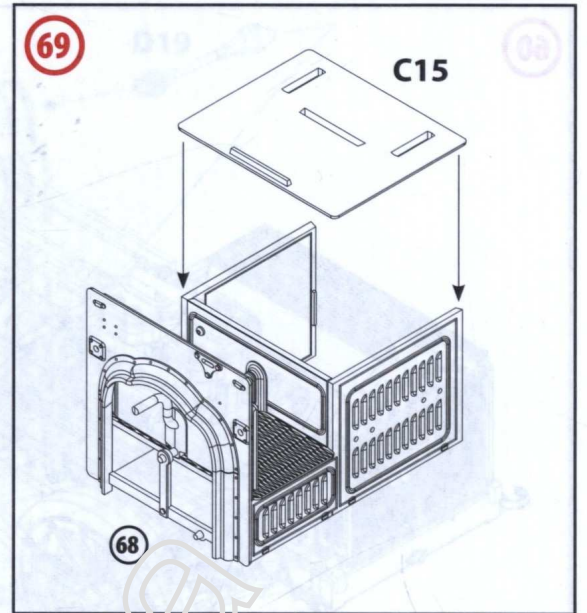
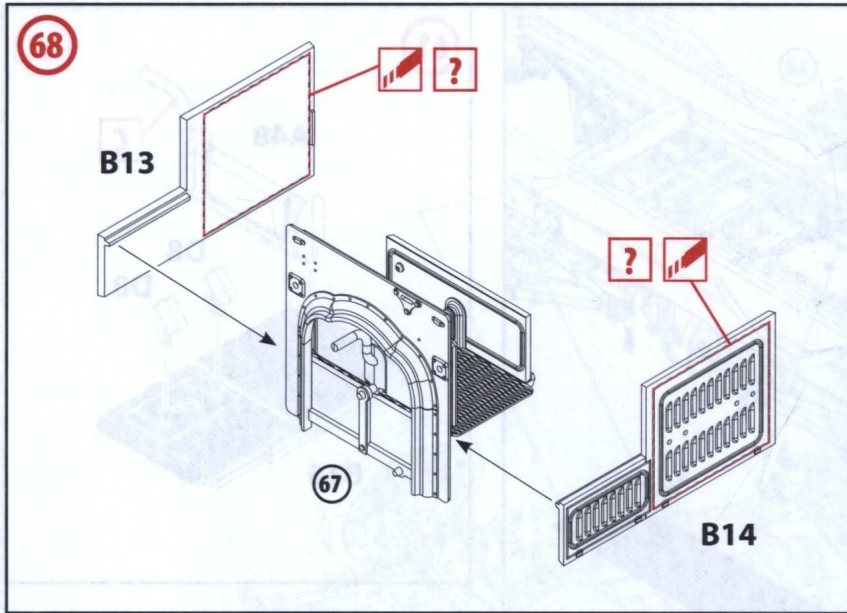

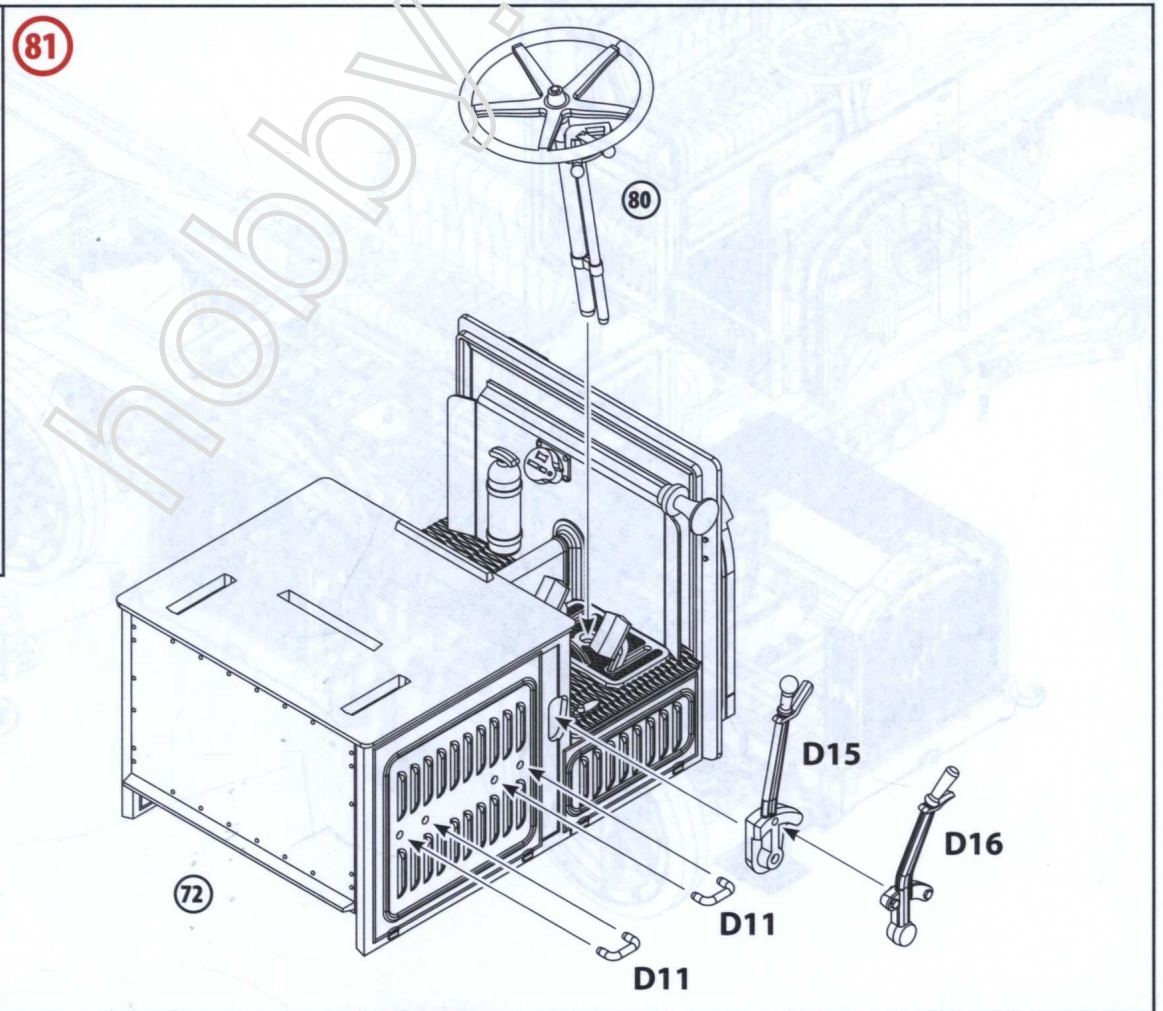
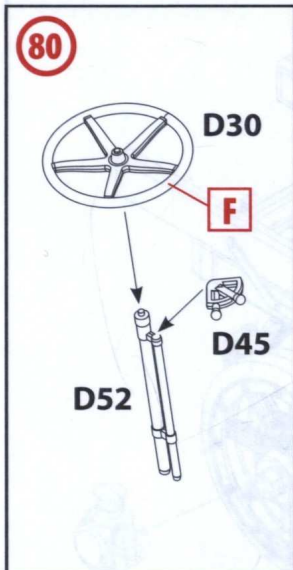
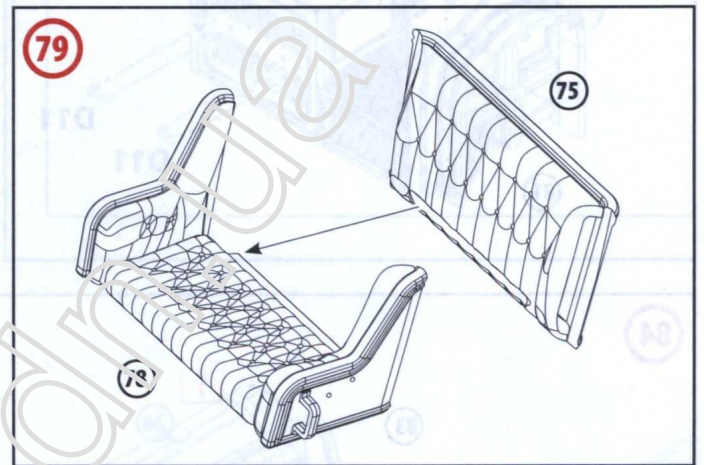
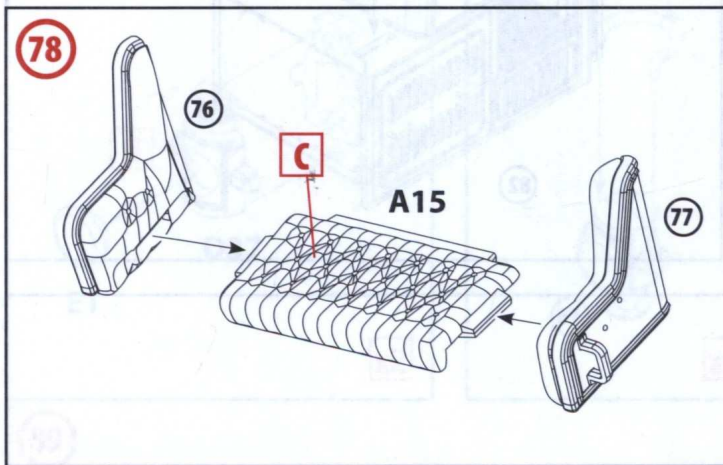
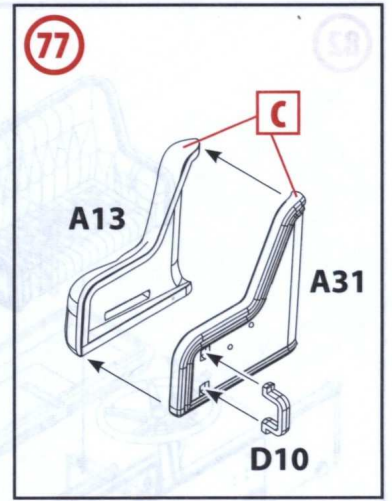
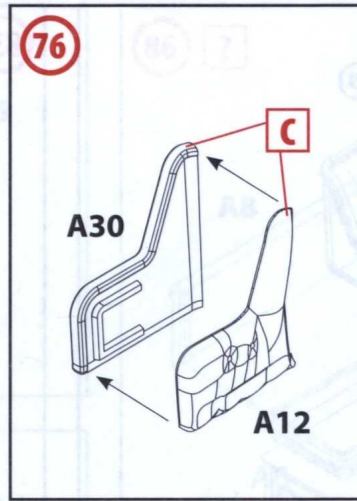
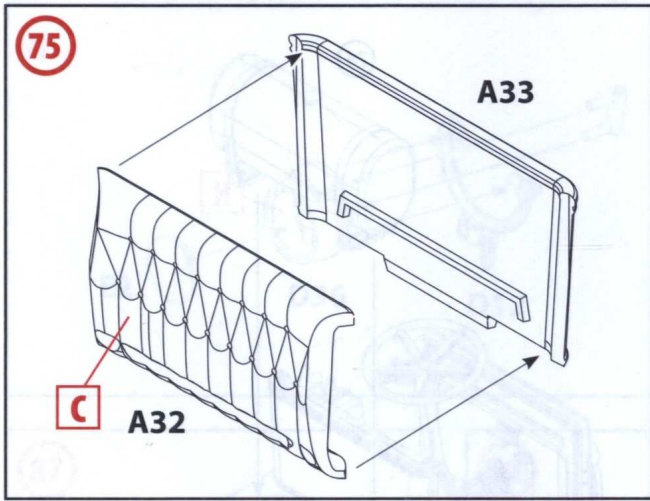

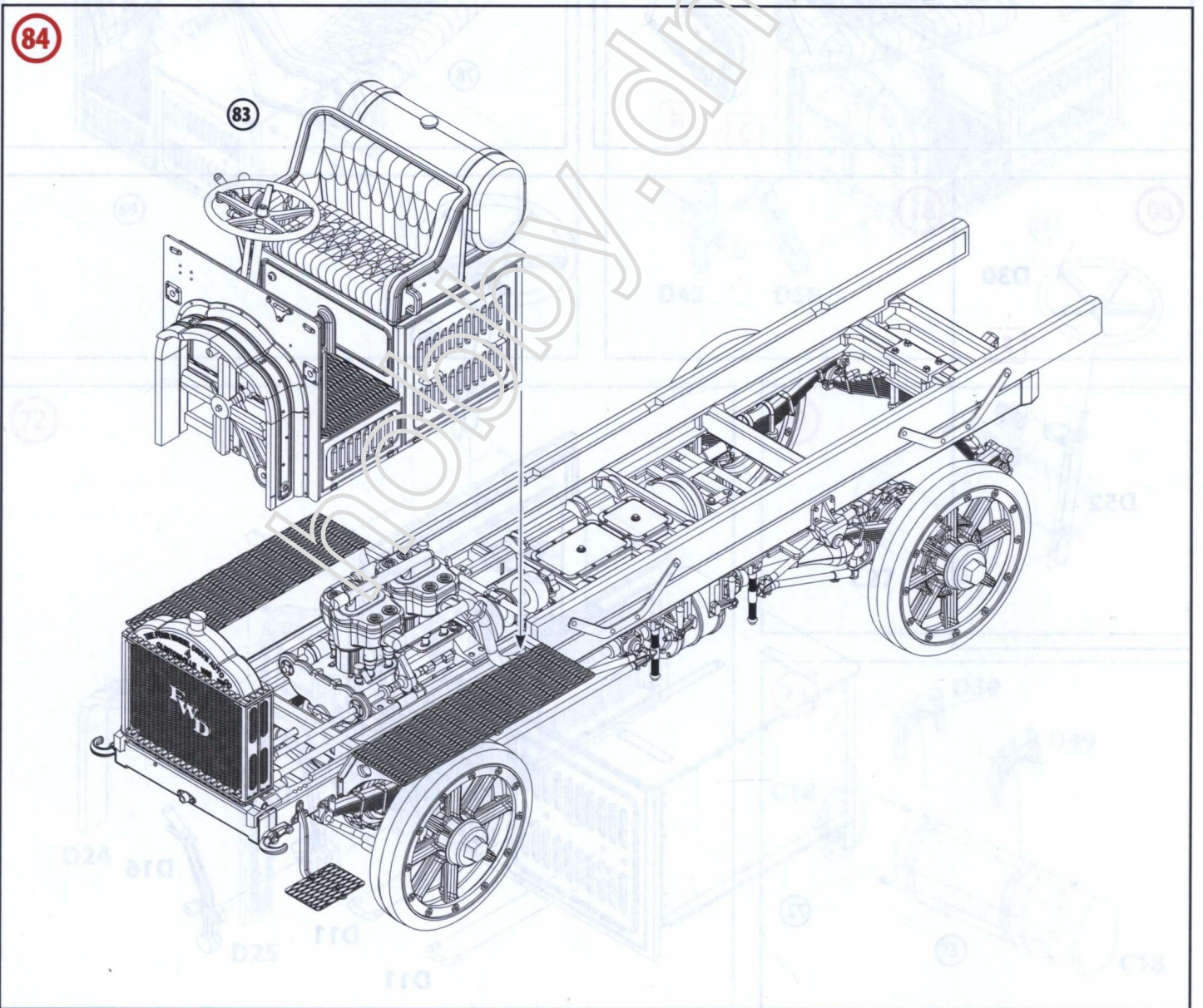
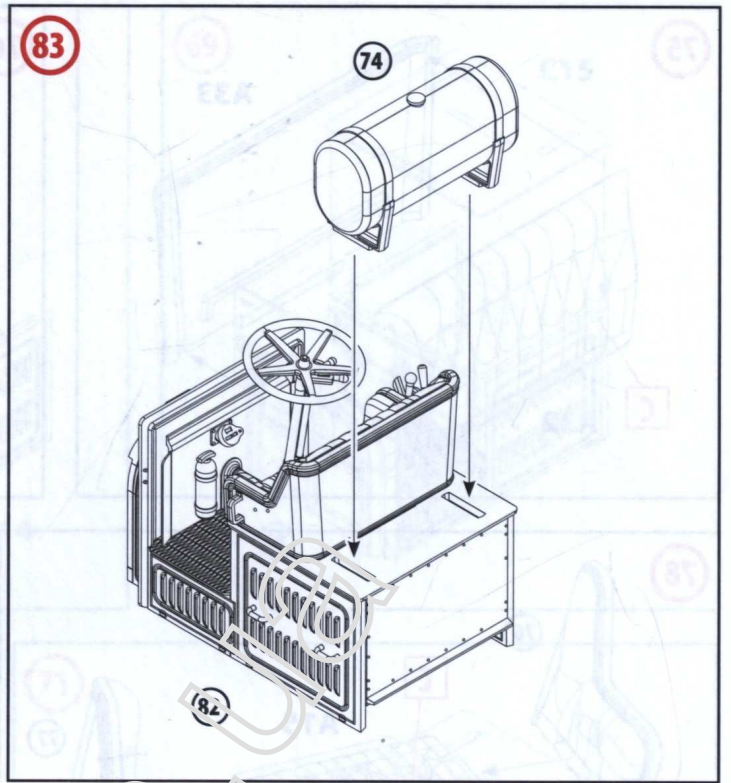
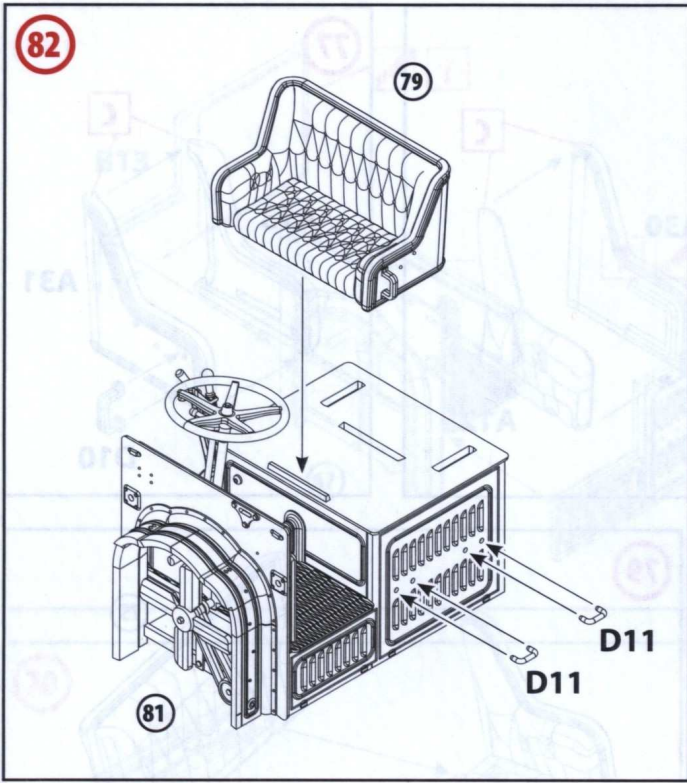

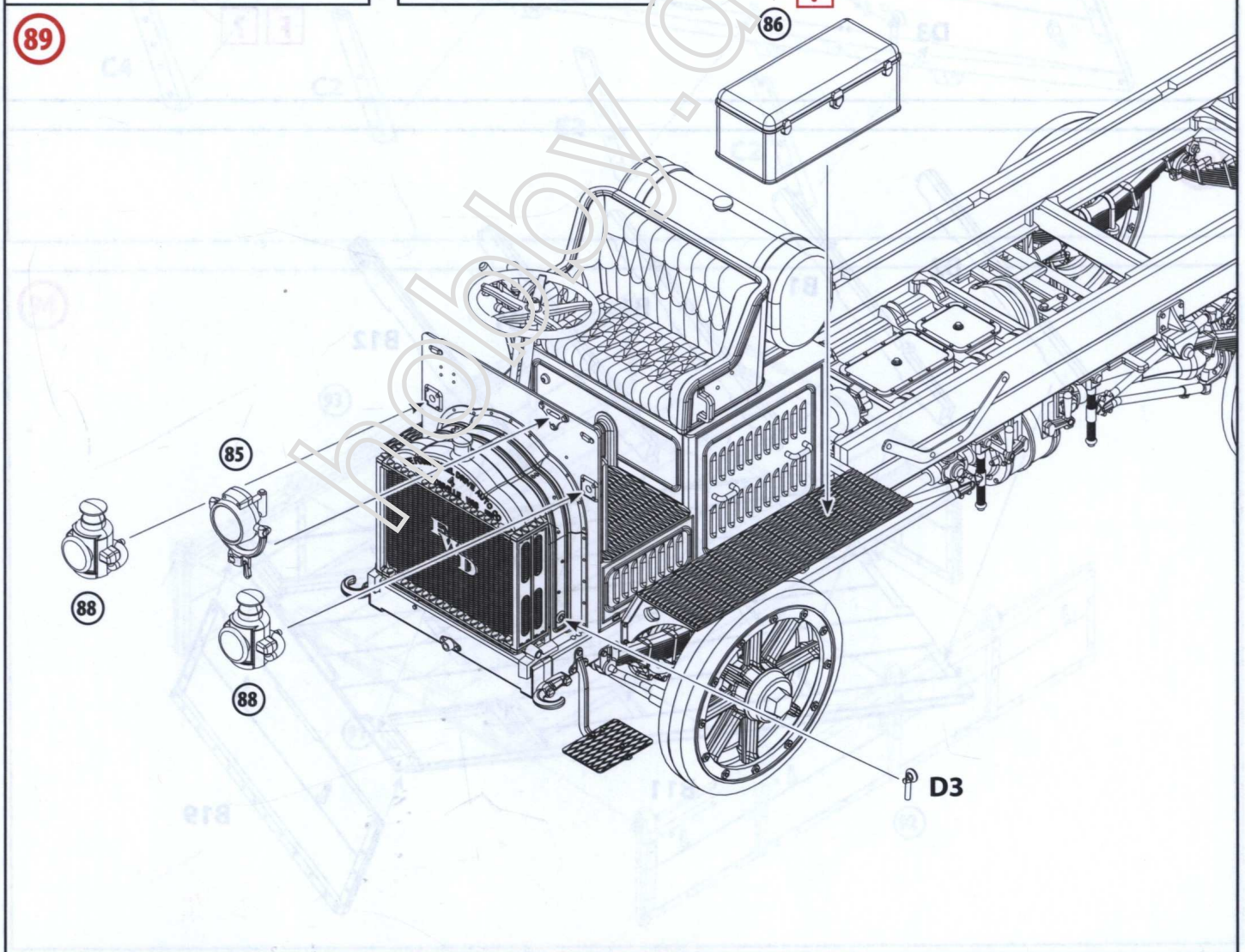
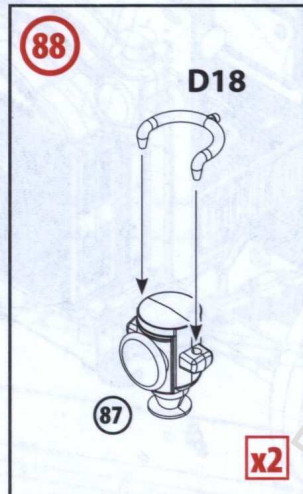
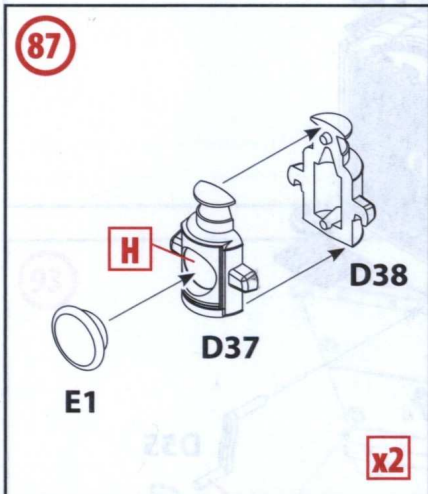
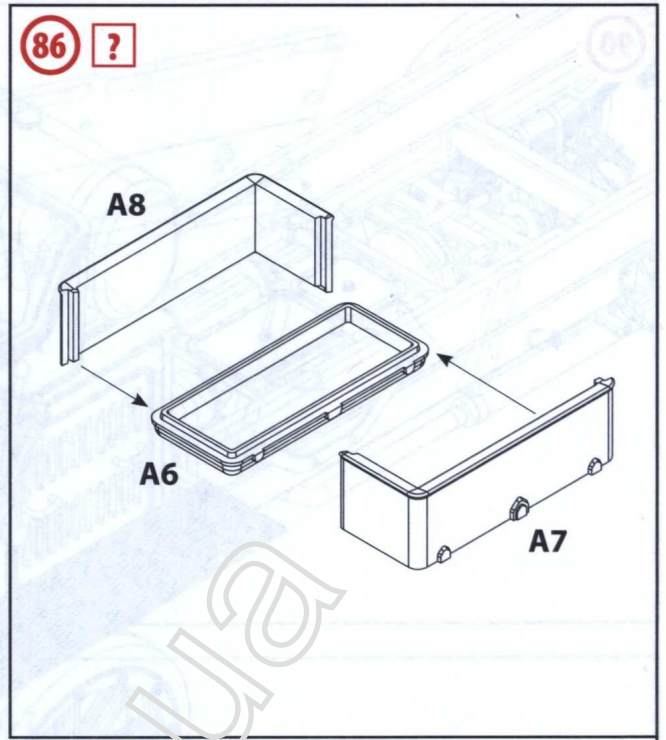
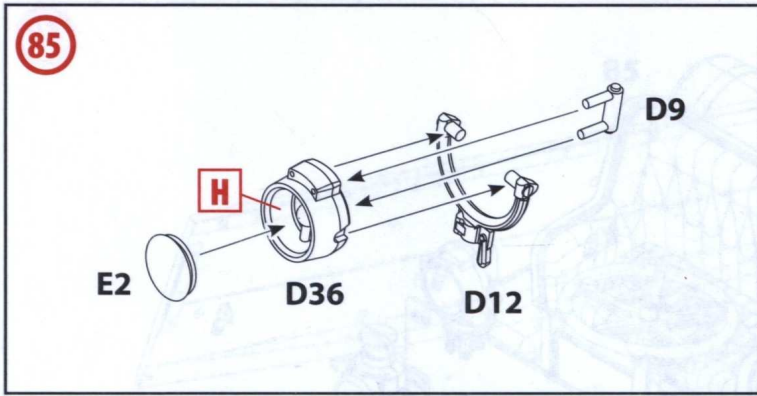

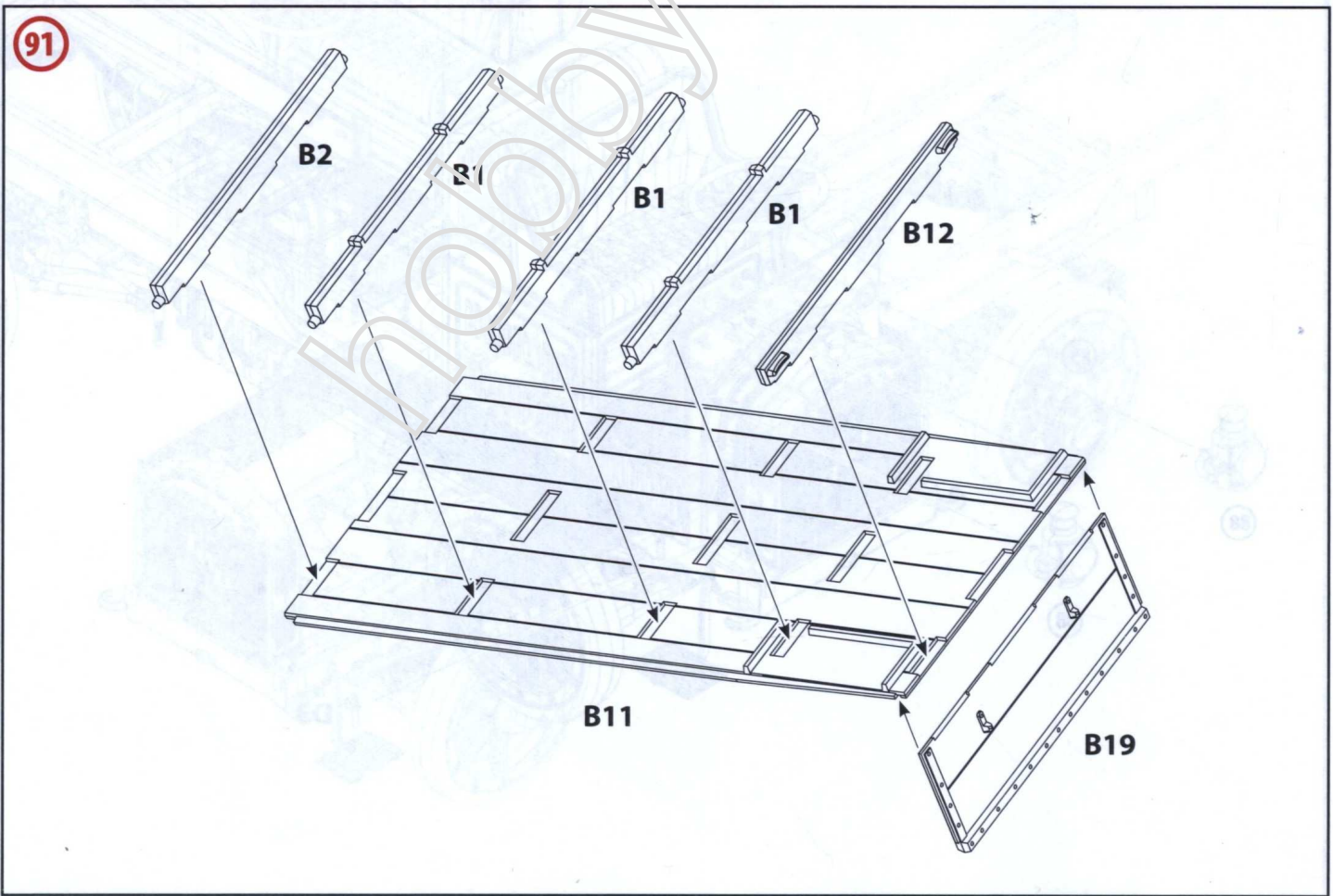
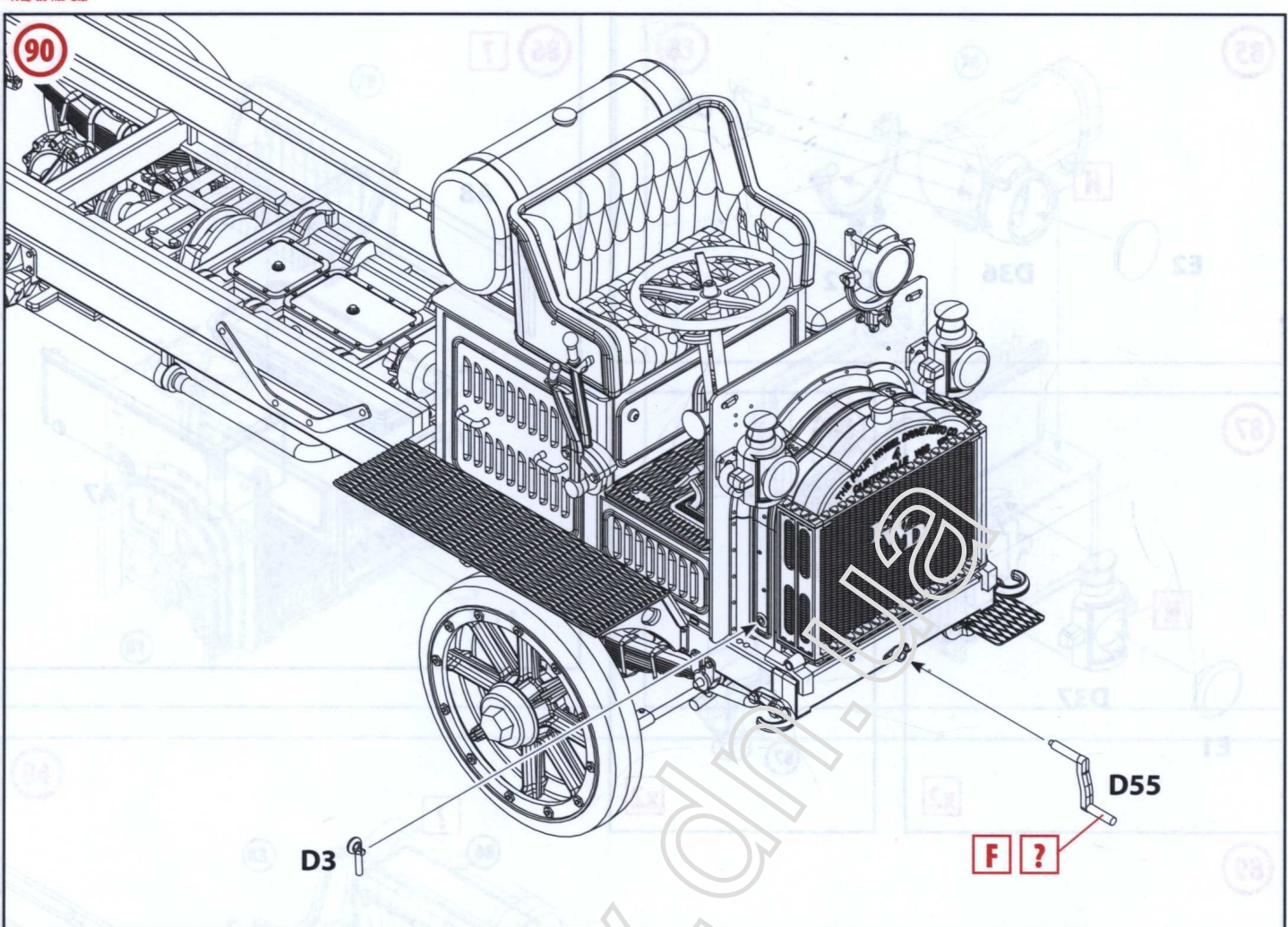

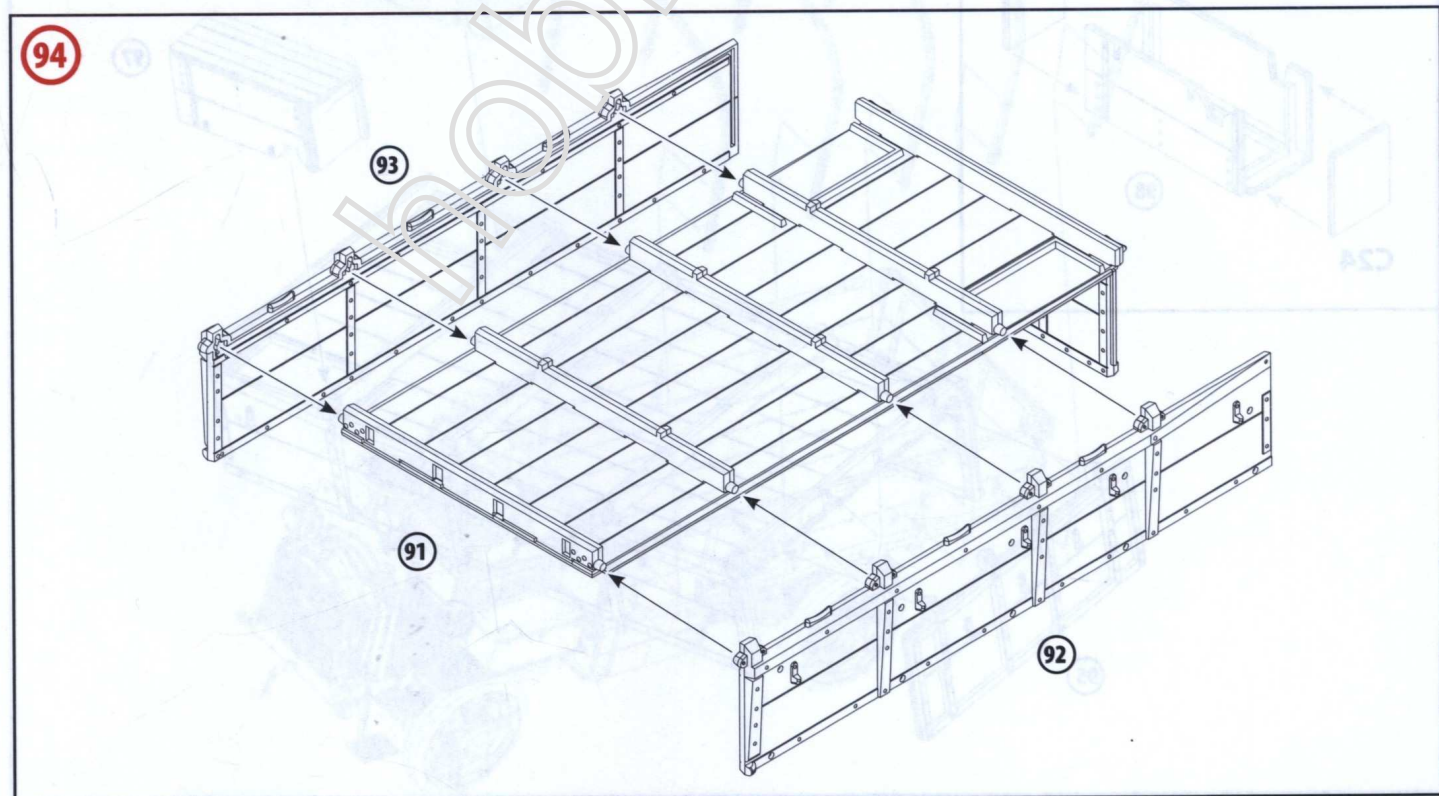
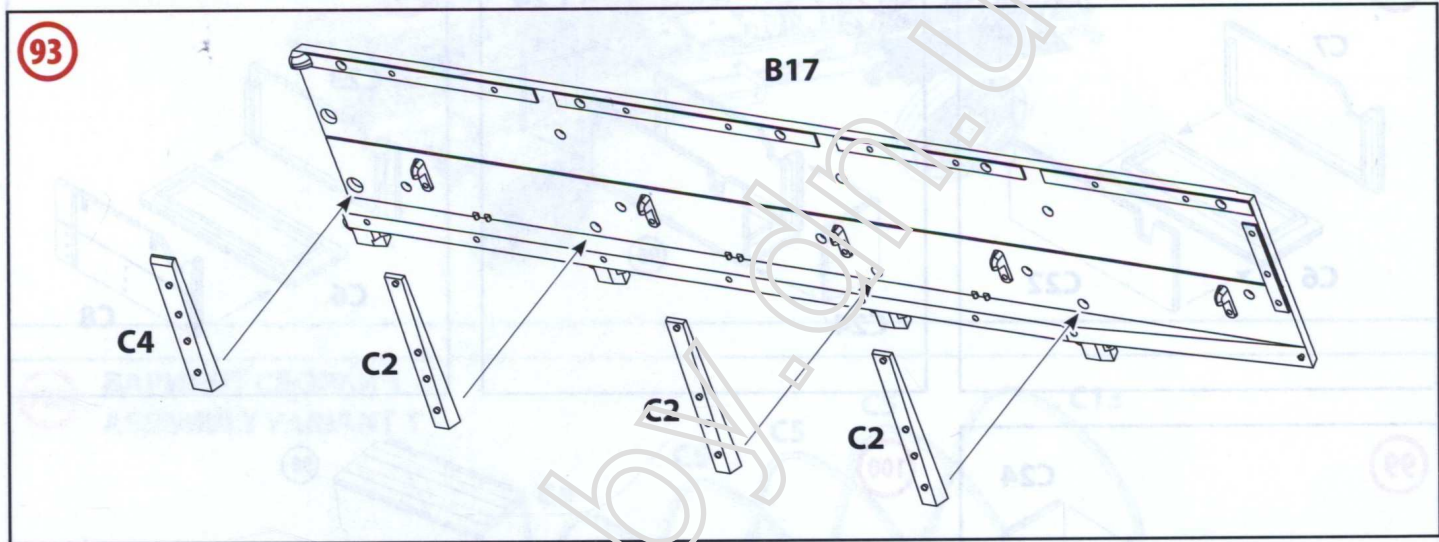
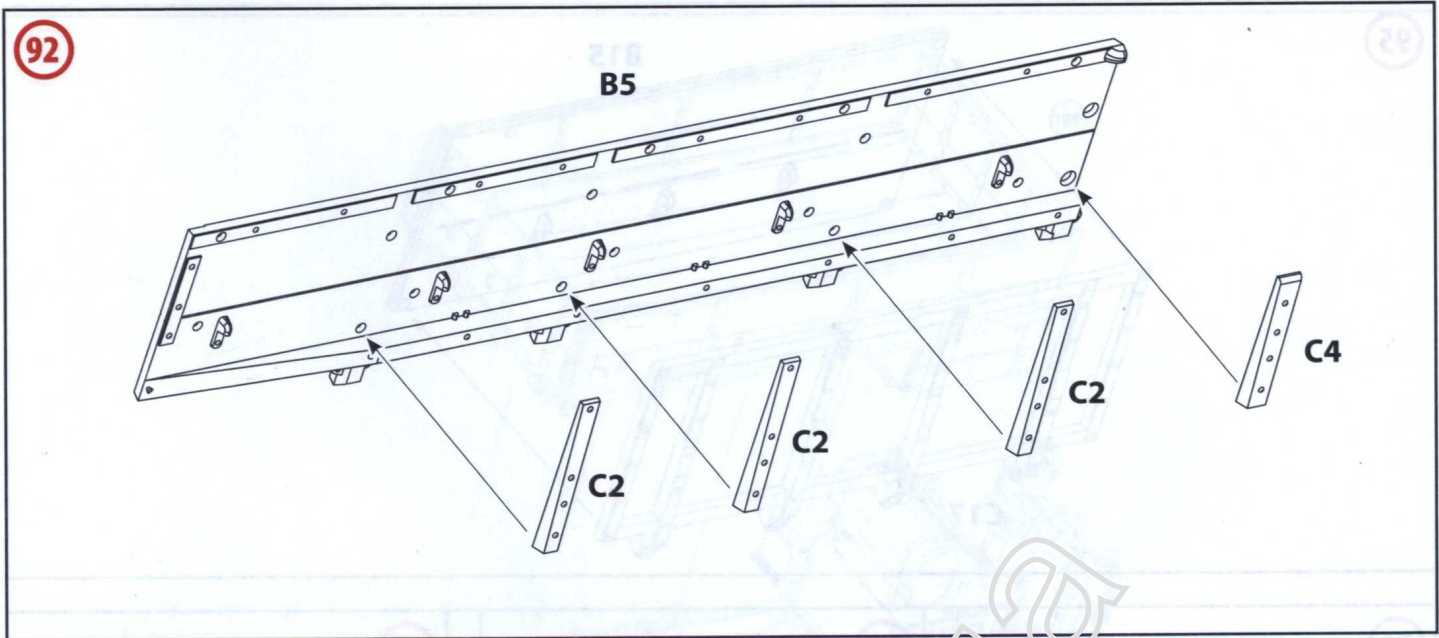

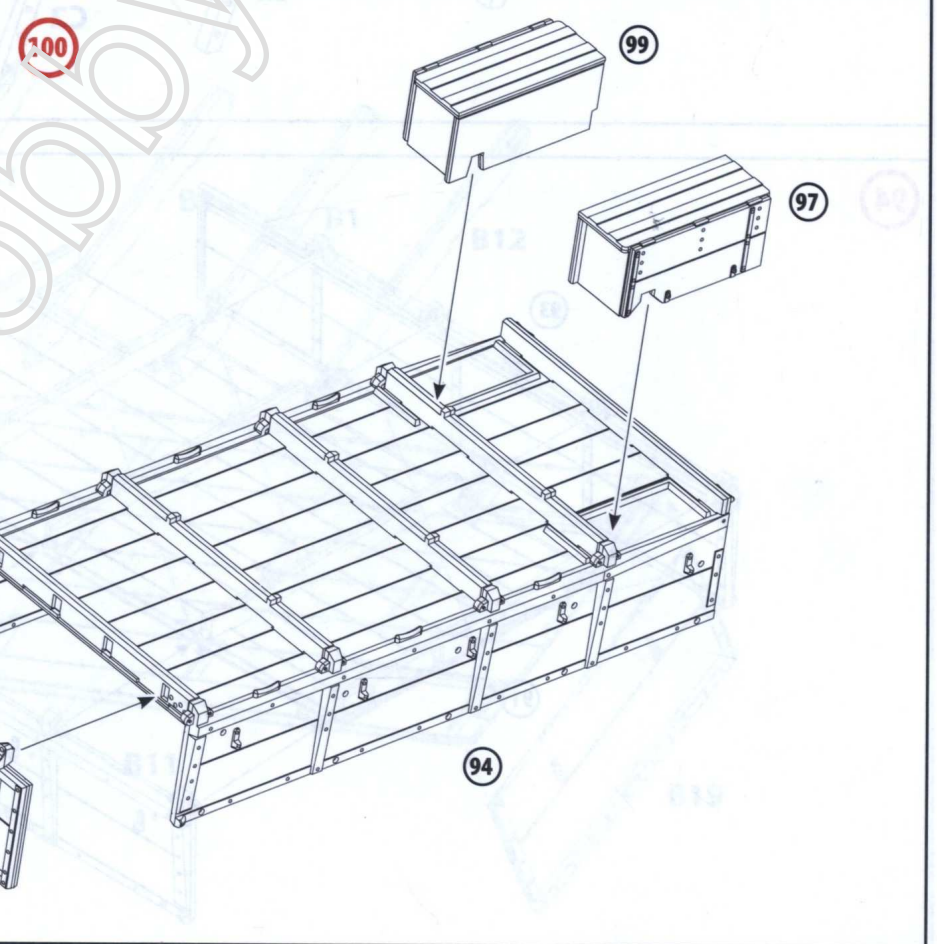
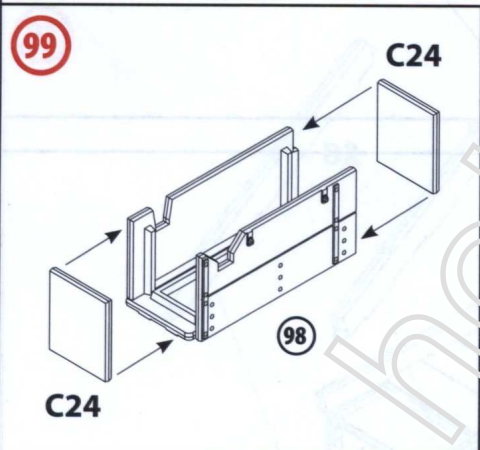
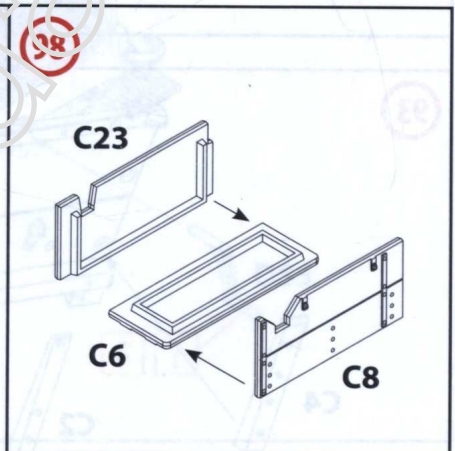
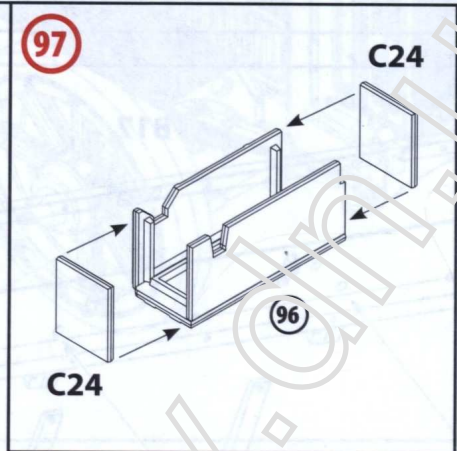
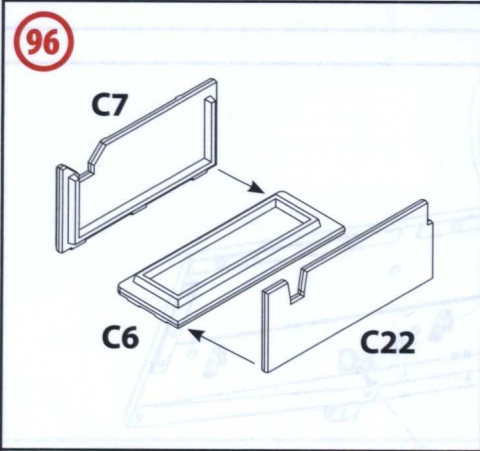
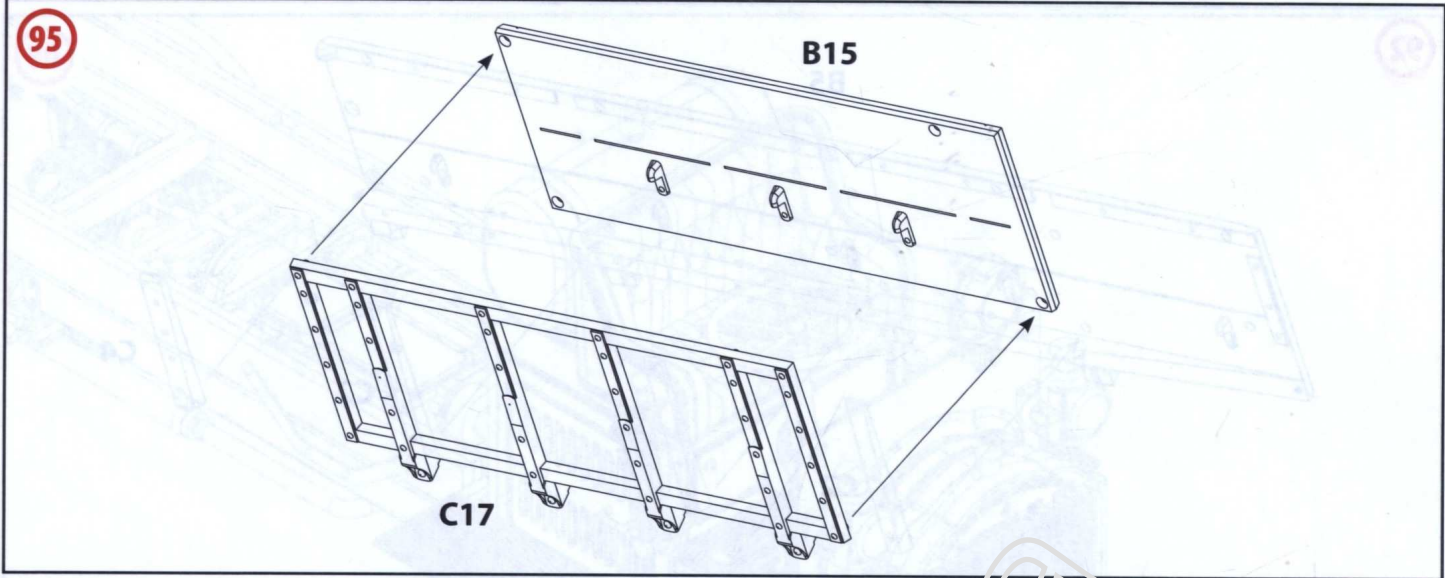

101

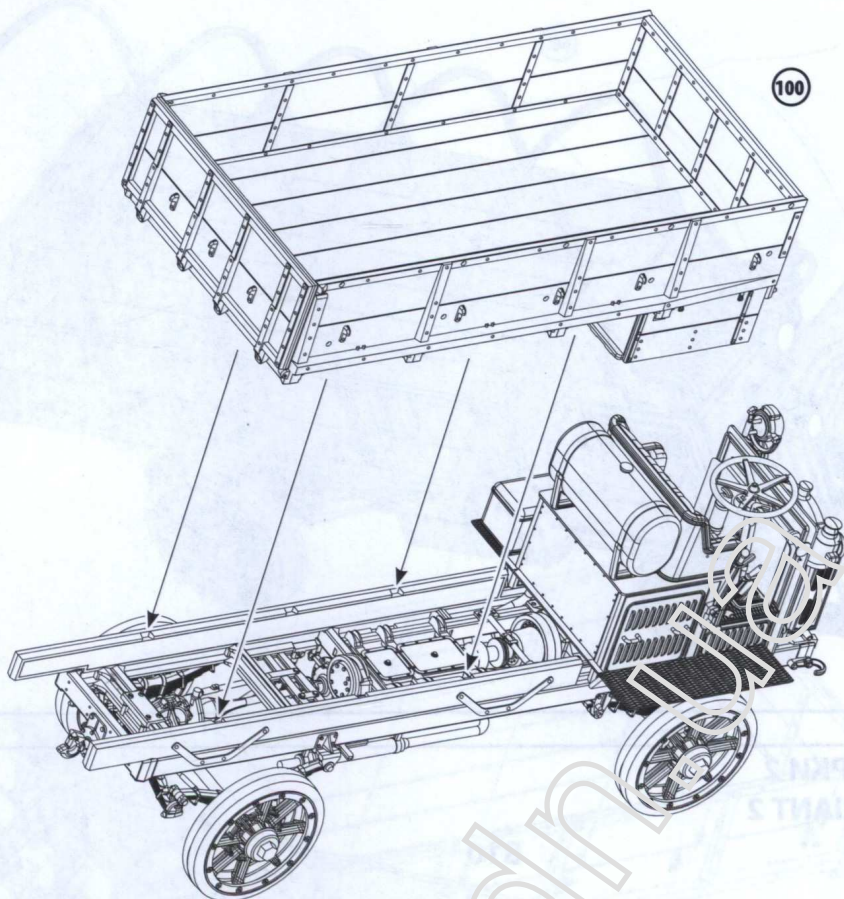

102

ВАРИАНТ СБОРКИ 1
ASSEMBLY VARIANT 1

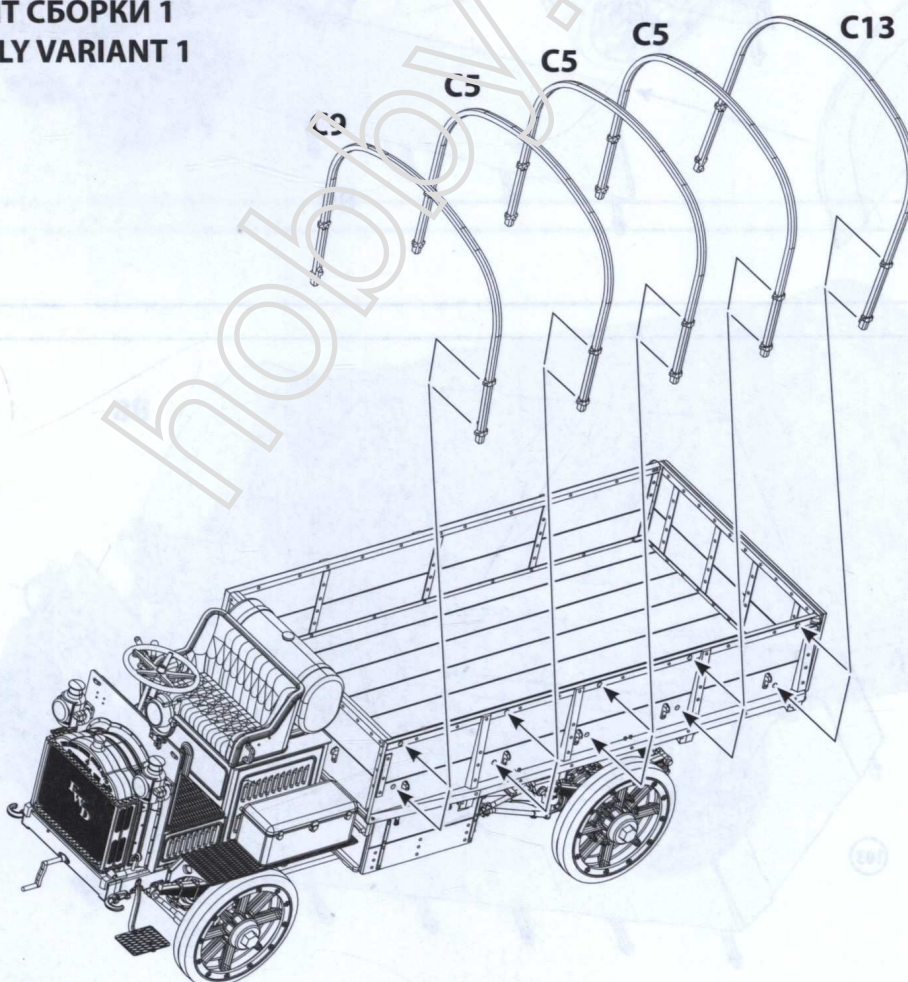

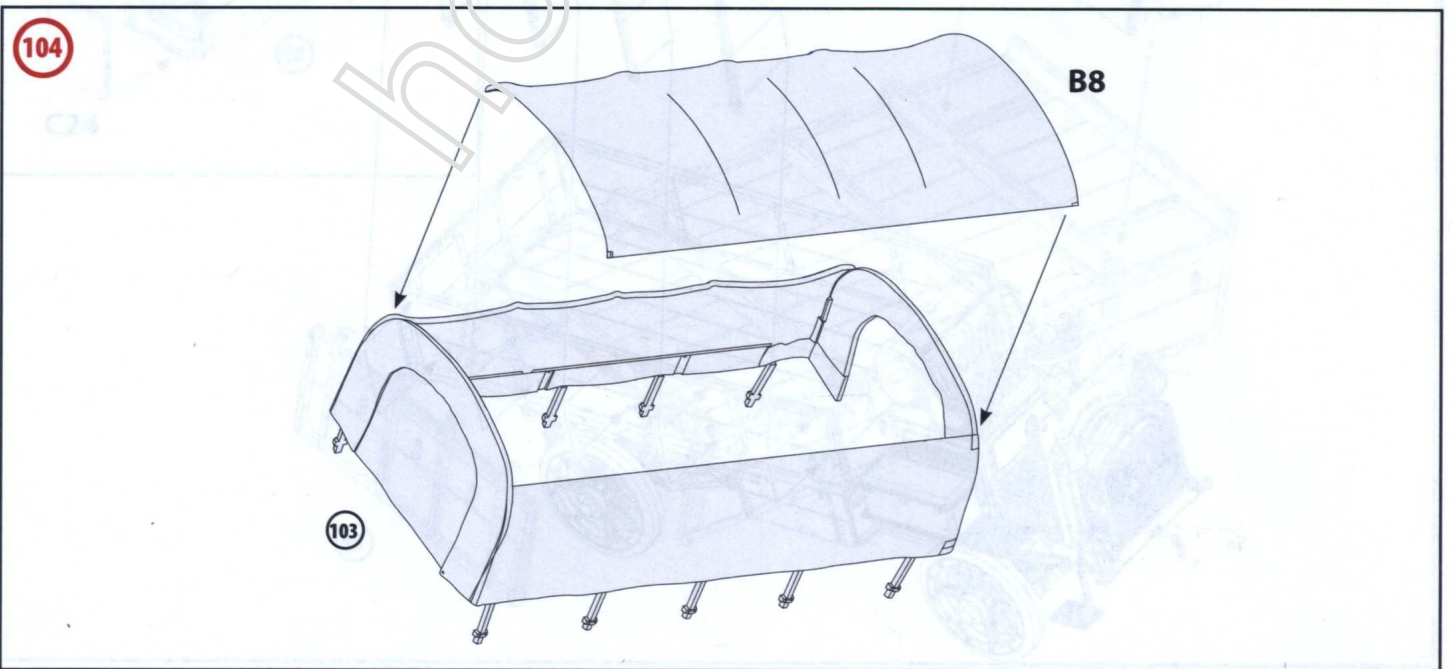
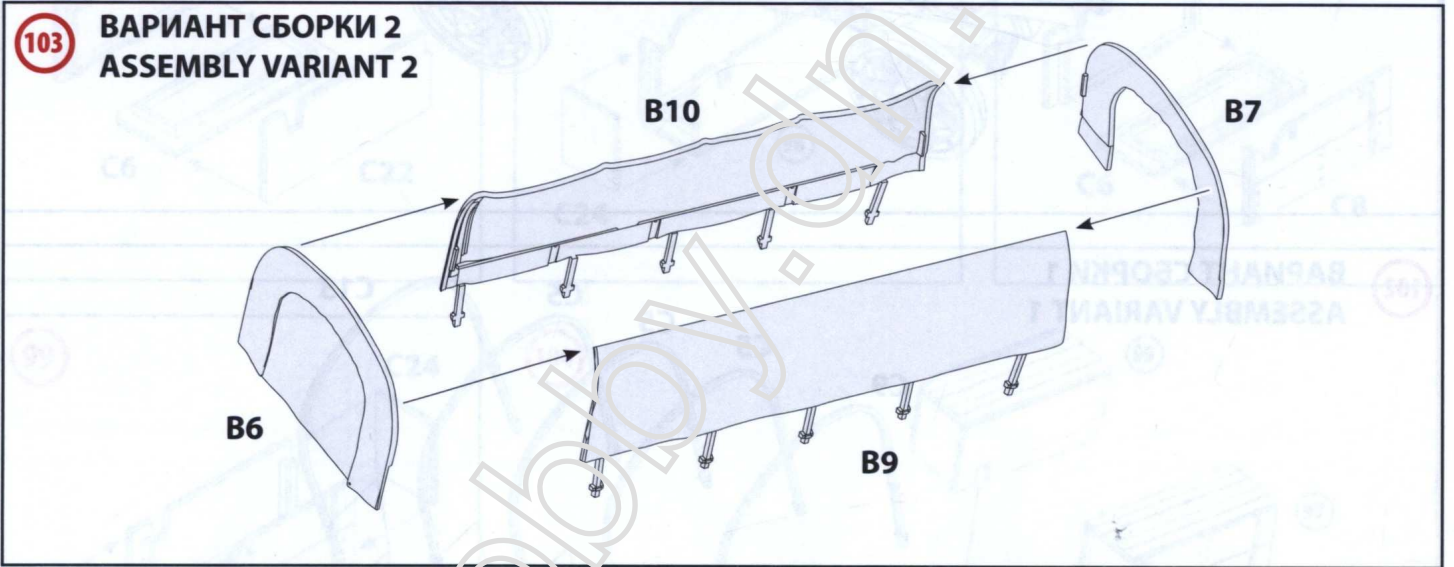
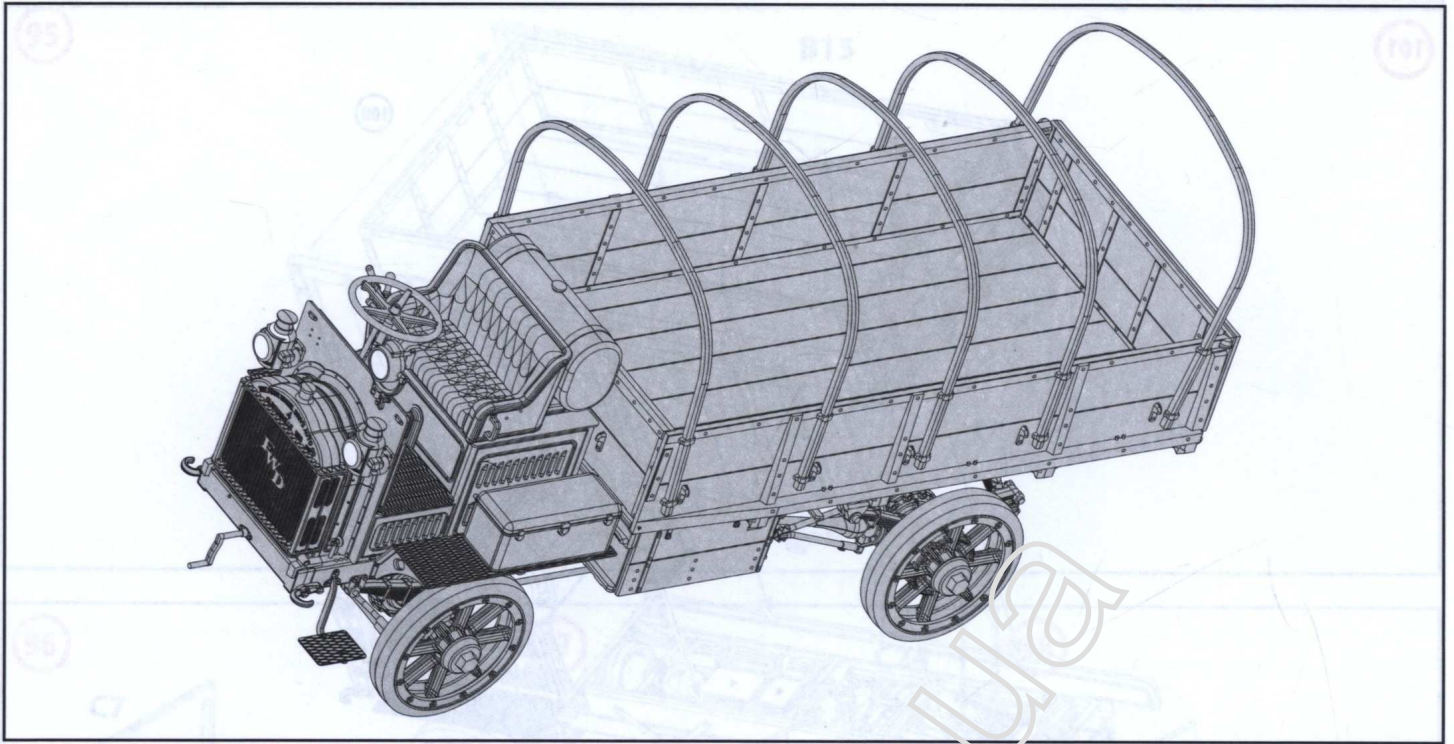

105

104

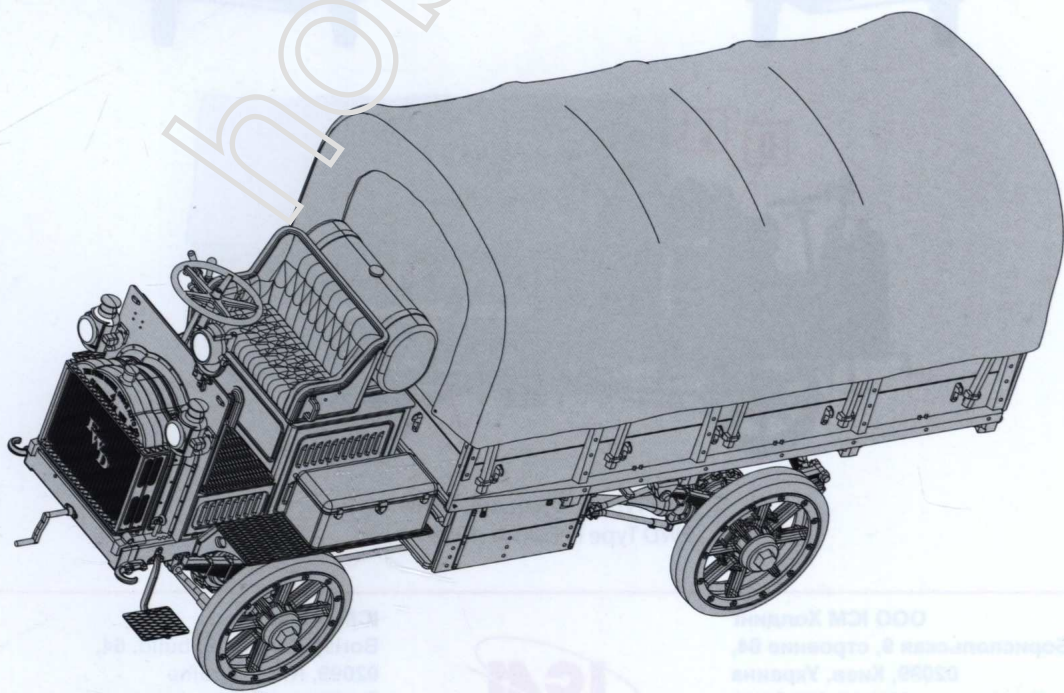
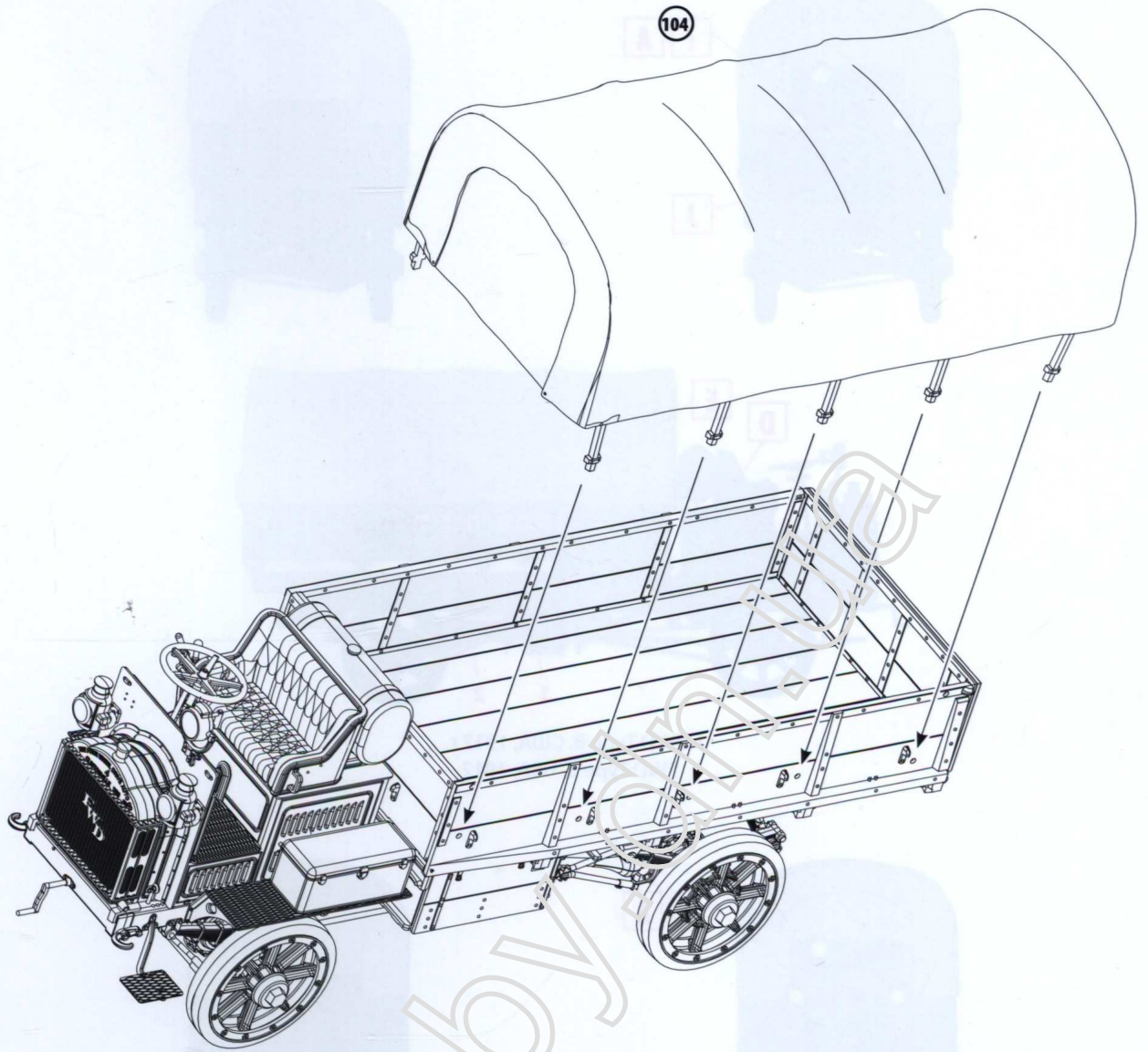

ICM
000 ICM Xarand
ул. Бейшеналиева 8, корпус 8А
02058, Ташкент, Узбекистан
Тел/факс: +30(044) 389 04 12

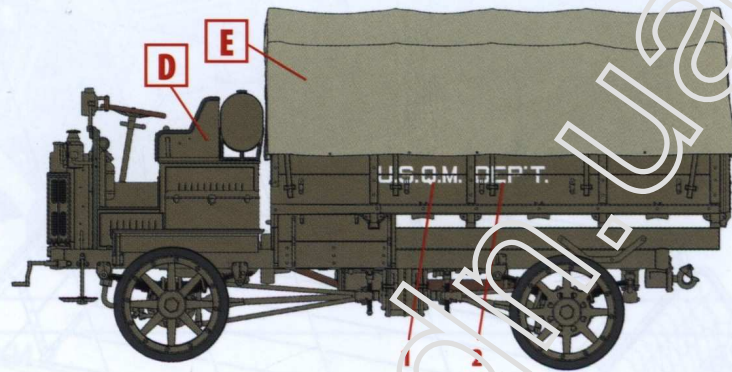
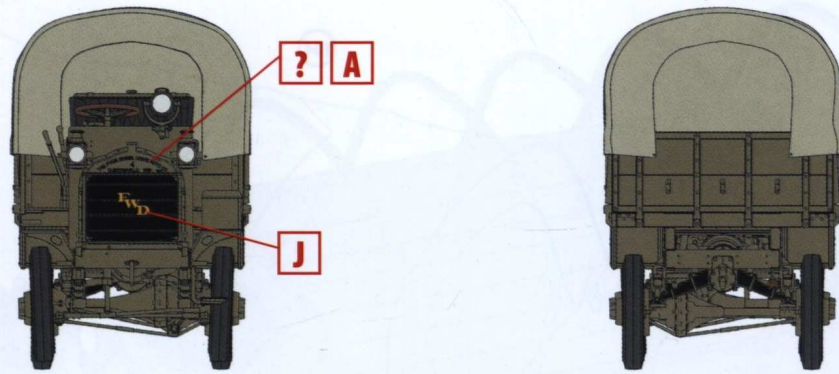

1. FWD Type B, США, 1917 г.
 FWD Type B, USA, 1917

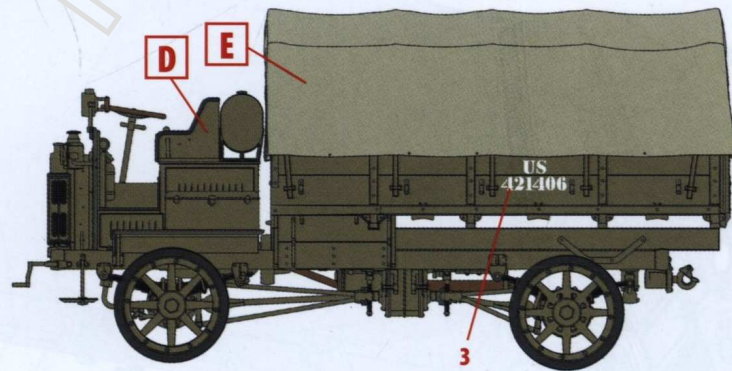

2. FWD Type B, Франция, 1918 г.
 FWD Type B, France, 1918