



DB-26B/C with Q-2 drones

1/48 SCALE MODEL KIT No 48286

DB-26B/C с беспилотными самолетами Q-2

Несколько самолетов семейства Invader прошли переоборудование в носители беспилотников. С самолетов снималось абсолютно все вооружение, а на пилонах под крылом подвешивались беспилотные самолеты-мишени. Такие машины применялись в процессе подготовки летчиков истребительной авиации, а дроны выступали в качестве мишеней, имитирующих реальные воздушные цели. После выполнения задачи беспилотники приземлялись с помощью парашюта и в дальнейшем использовались повторно.

Свои беспилотники были у ВВС, у сухопутных войск и у военно-морского флота, хотя зачастую они использовали одну и ту же модель с незначительными доработками.

Тактико-технические характеристики DB-26B/C с беспилотными самолетами Q-2

Длина, м	15,62
Размах крыла, м	21,34
Максимальный взлетный вес, кг	18960
Двигатель	2x Пратт Уитни R-2800, 2000 л.с.
Максимальная скорость, км/ч	518
Потолок, м	7467
Дальность полета максимальная, км	4660

DB-26B/C with Q-2 drones

Several aircraft of the Invader family have been converted into drone carriers. Absolutely all weapons were removed from the planes, and unmanned target aircraft were suspended on pylons under the wing. Such machines were used in the training of fighter pilots, and drones acted as targets imitating real air targets. After completing the task, the drones landed with a parachute and were subsequently reused.

The Air Force, the Army and the Navy had their own drones, although they often used the same model with minor modifications.

Tactical and Technical Specifications of DB-26B/C with Q-2 drones

Length, m	15,62
Span, m	21,34
Max take-off weight	18960
Engine	2x Pratt Whitney R-2800, 2000 hp
Max. Speed, km/h	518
Service Ceiling, m	7467
Max ferry range	4660

ИСПОЛЗУЕМЫЕ КРАСКИ / USED COLORS:

COLOR	ICM	Revell	Tamiya
A Красный Deep Red	1007	131	X7
B Черный Black	1002	106	XF85
C Алюминий Aluminium	1023	199	XF16
D Желтый Deep Yellow	1003	112	XF3
E Оранжевый средний Medium Orange	1003+4045	-	-
F Небесно-серая Sky Grey	1033	143	XF20
G Оливковый Olive Green	1068	360	XF5
H Серебро Silver	1024	190	X11

COLOR	ICM	Revell	Tamiya
J Сталь Natural Steel	1025	191	X32
K Оружейная сталь Gun metal	1027	109	X10
L Черная резина Rubber Black	1039	106	XF85
M Полупрозрачный красный Clear Red	1011	731	X27
N Полупрозрачный зеленый Clear Green	1014	161	X25
P Белый White	1001	105	XF2
Q Латунь Brass	1018	195	X31

Для получения глянцевого, сатинового или матового эффекта - используйте наши лаки!

For a glossy, satin or matte effect - use our varnishes!



2001
МАТОВЫЙ ЛАК
VARNISH MATT



2002
САТИНОВЫЙ ЛАК
VARNISH SATIN



2003
ГЛЯНЦЕВЫЙ ЛАК
VARNISH GLOSS

01 СТАДИЯ СБОРКИ
ASSEMBLY STEP

A ИСПОЛЗУЕМАЯ КРАСКА
USED COLOR

□ ПРИ СБОРКЕ НЕ ИСПОЛЗУЕТСЯ
PARTS NOT FOR USE

03 СБОРОЧНАЯ ЕДИНИЦА
ASSEMBLY UNIT

x2 СДЕЛАТЬ ДВЕ ДЕТАЛИ
MAKE 2 PCS

***** СДЕЛАТЬ САМОМУ
SCRATCH BUILD

✂ ОТРЕЗАТЬ
CUT OFF

? ПРОИЗВОЛЬНЫЙ ВЫБОР
OPTIONAL

! ЗАШПАКЛЕВАТЬ
PUTTY

⊠ НЕ КЛЕИТЬ
DO NOT CEMENT

⚪ ПРОСВЕРЛИТЬ
OPEN HOLE

В Н И М А Н И Е !

Перед сборкой внимательно прочитать руководство по монтажу. Каждая деталь пронумерована. Соблюдать последовательность монтажа. Необходимые рабочие инструменты: нож и напильник для зачистки деталей; резиновая лента, клеевая лента и зажимы для сушки белья для прижимания склеиваемых деталей. Детали из пластика очистить в растворе мягкого моющего средства и высушить на воздухе для того, чтобы краска и переводные картинки лучше прилипали. Перед приклеиванием проверить, подходят ли детали; клей наносить экономно. Хром и краску удалить с поверхностей склеивания. Небольшие детали покрасить перед тем, как они будут удалены из рамок. Краску необходимо хорошо просушить, только после этого продолжать сборку. Каждую соответствующую переводную картинку отдельно вырезать и примерно на 20 секунд окунуть в теплую воду. На обозначенном месте картинку отделить от бумаги и прижать промокающей бумагой.

С А У Т И О Н !

Read the instructions thoroughly prior to assembly. Each component is numbered. Adhere to specified sequence of assembly. Tools required: knife and file for removal of components from frame; rubber bond, adhesive tape and clothes pegs for clamping components together after applying adhesive. Clean plastic components in a mild detergent solution and allow to air-dry so that paint and transfers adhere better. Prior to applying adhesive, check to see whether the components fit together; apply adhesive sparingly. Remove chrome and paint from the contact surfaces. Paint small components before removing them from the frame. Allow paint to dry well, and only then continue to assemble. Cut out each transfer individually and immerse in warm water for approx. 20 seconds. Slide transfer off paper and into designated position, then press on with blotting paper.

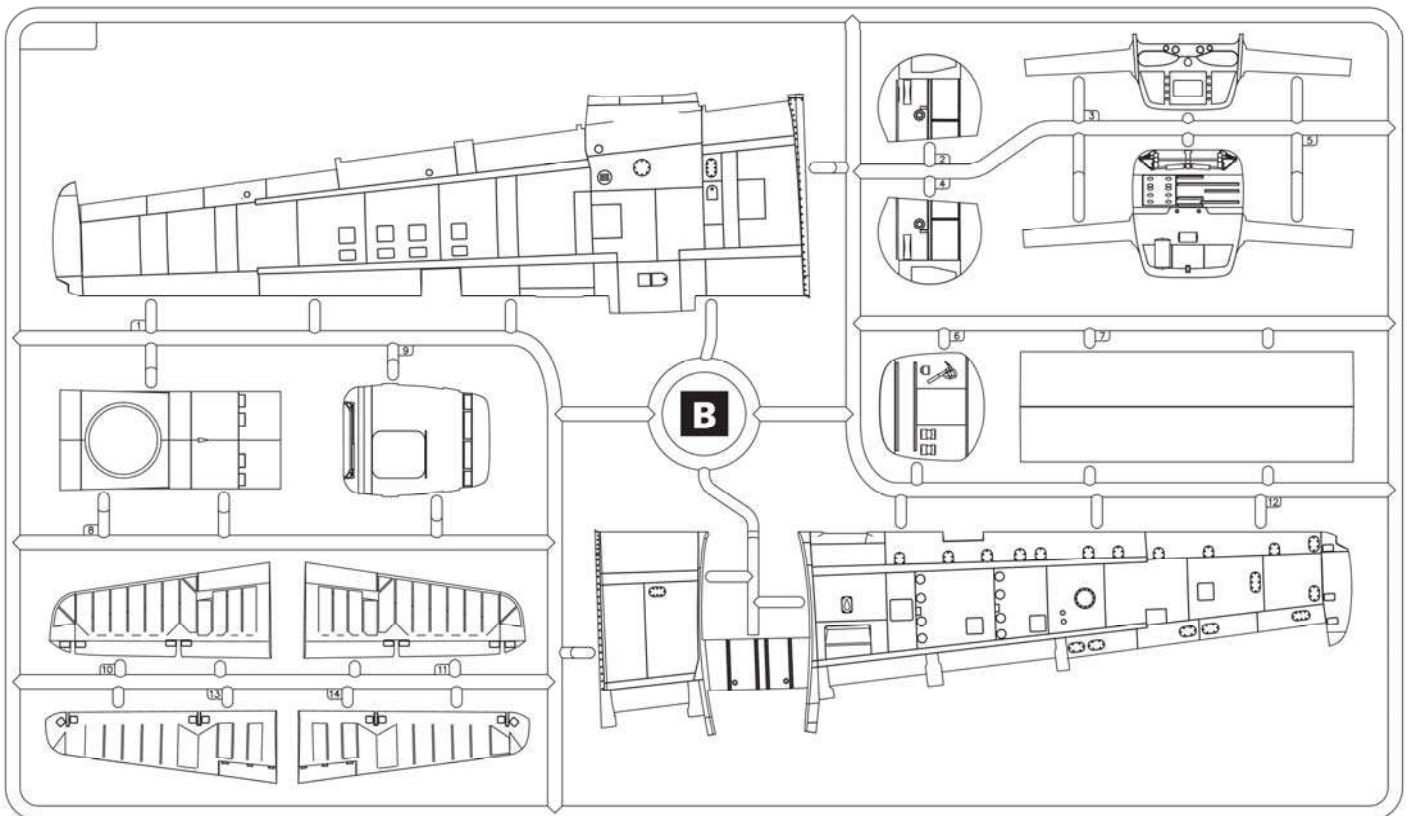
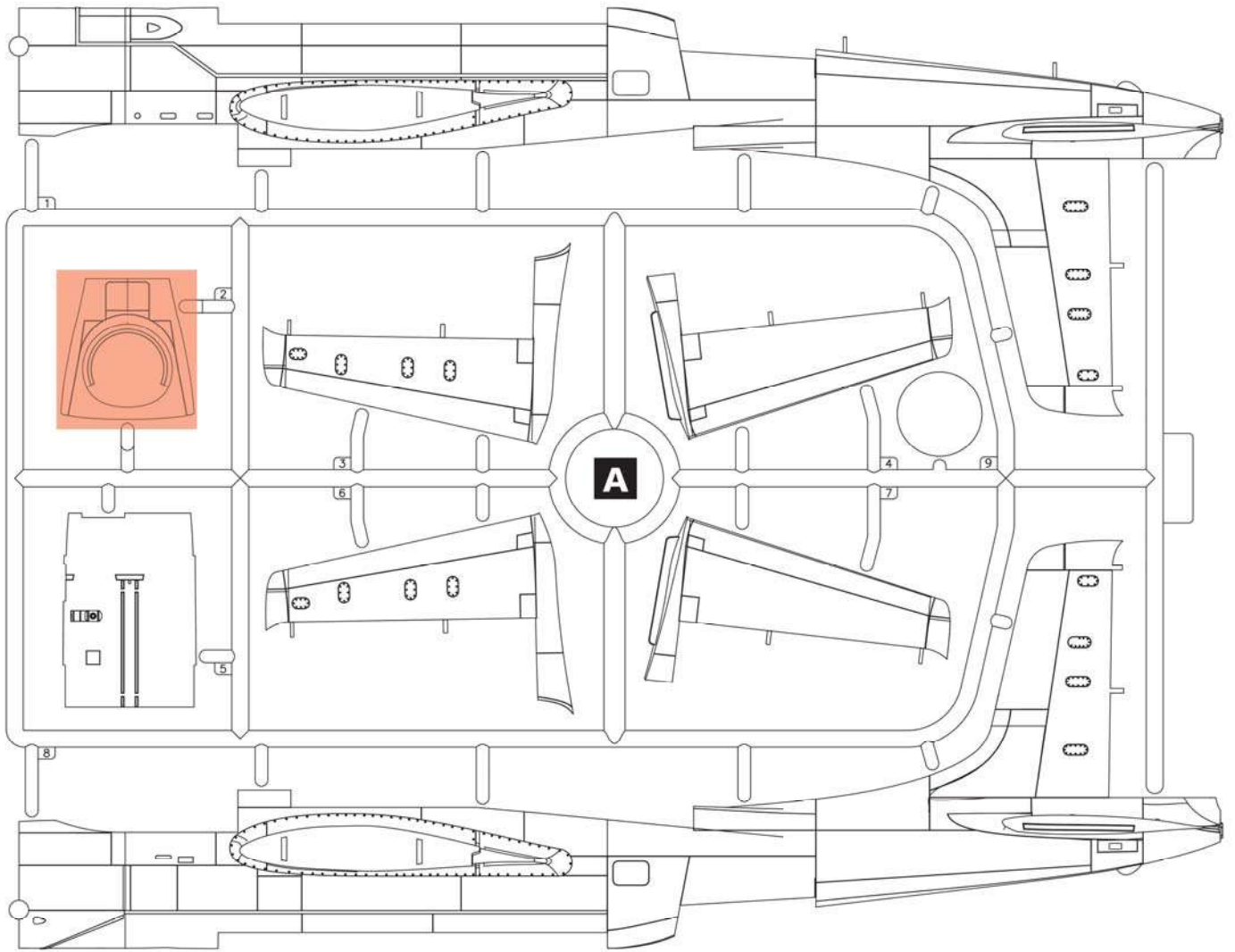

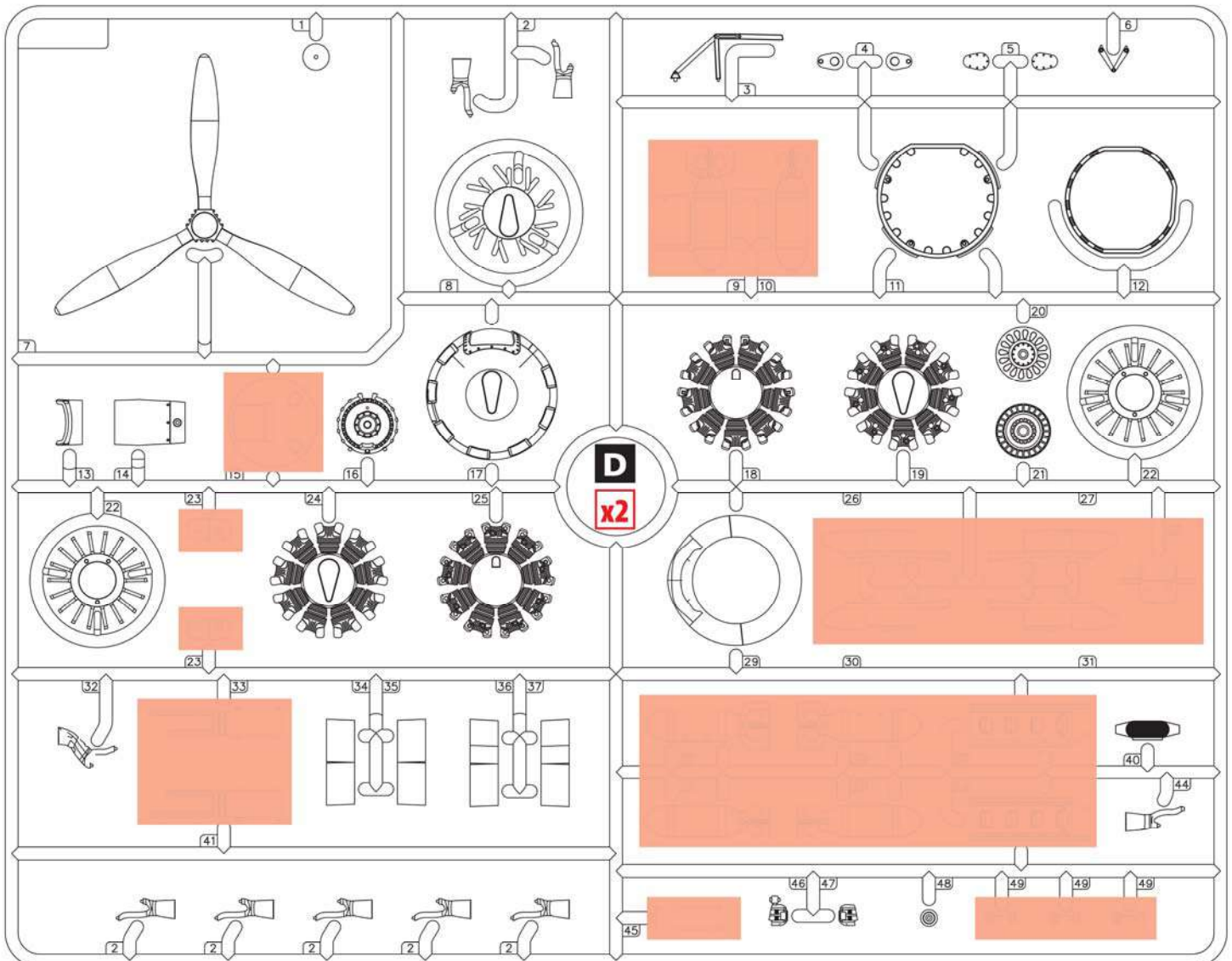
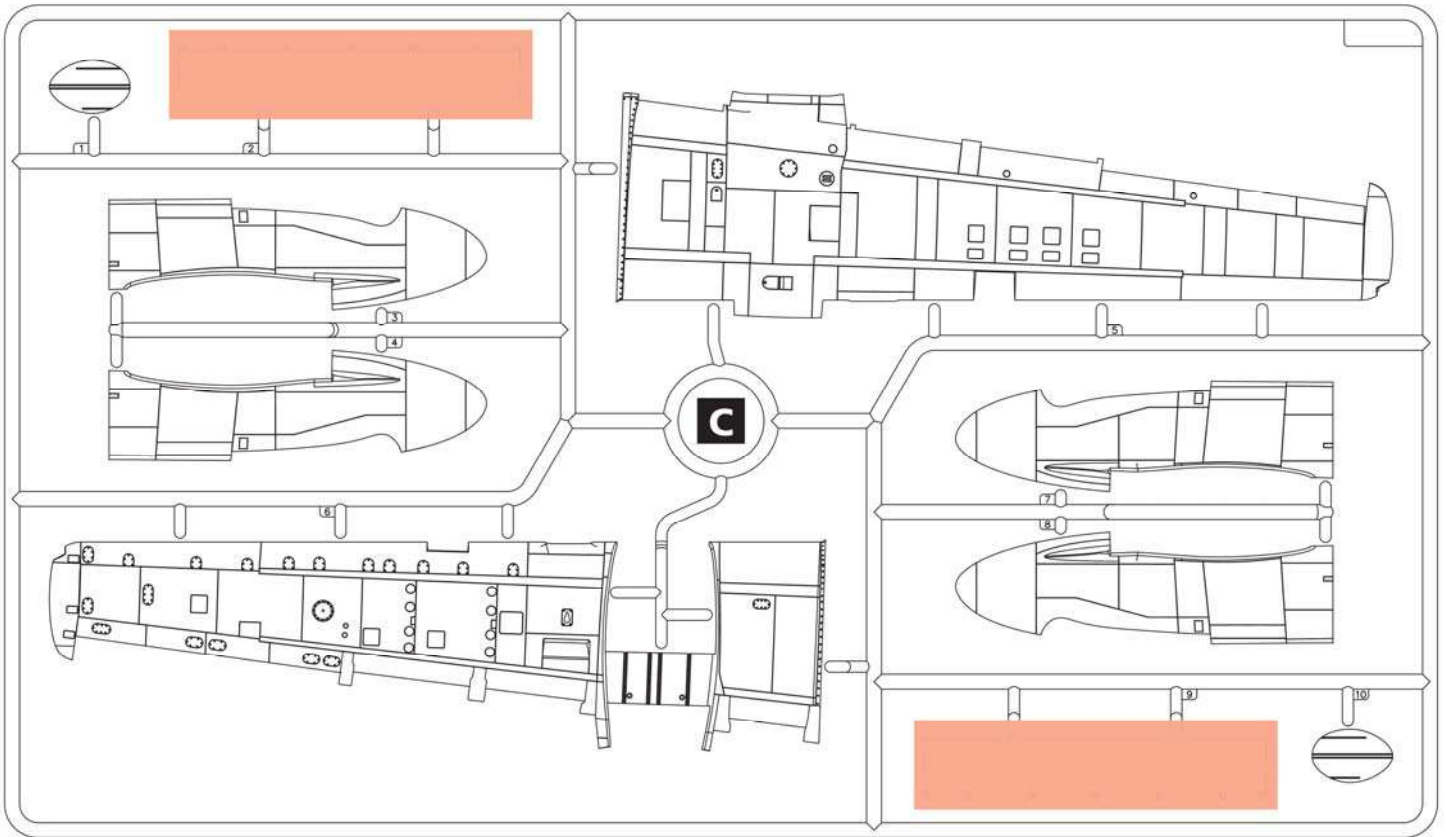

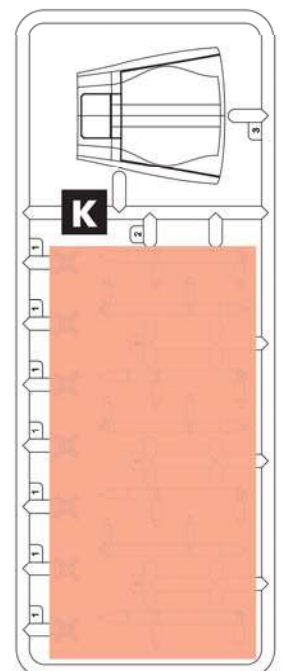
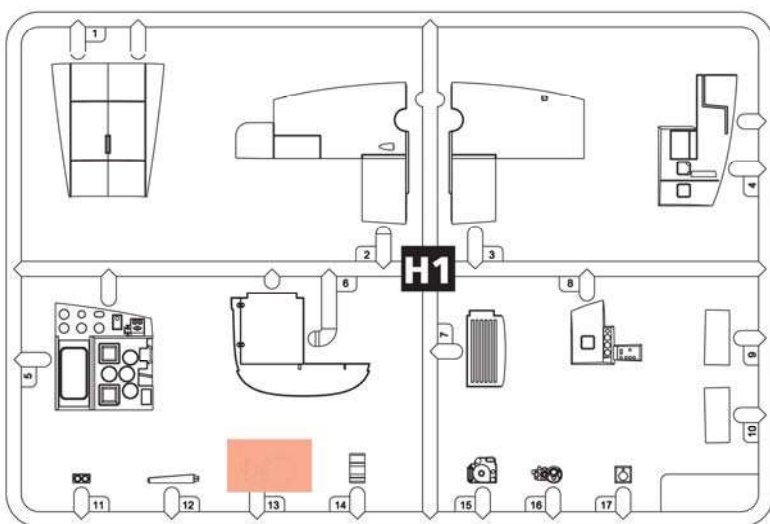
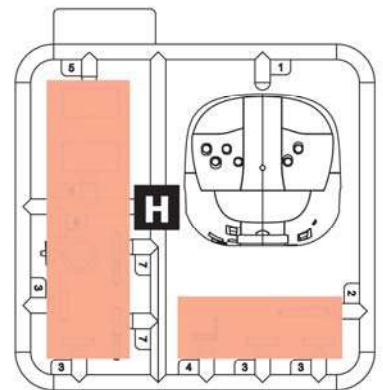
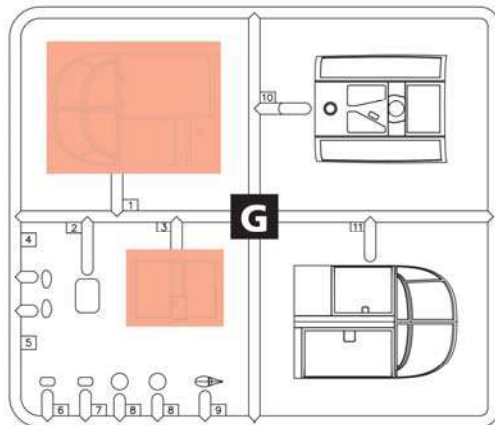
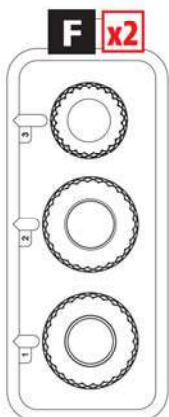
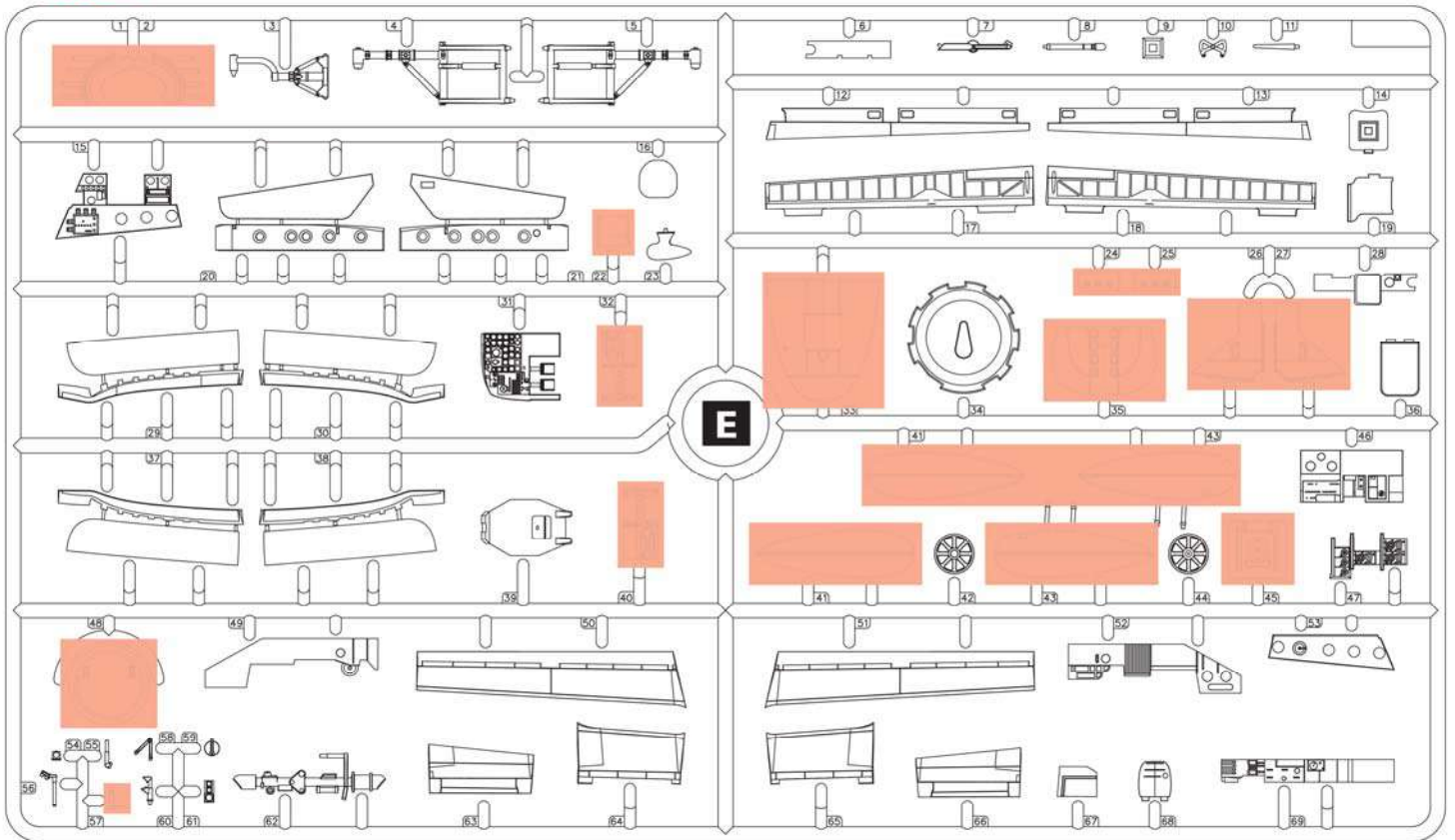

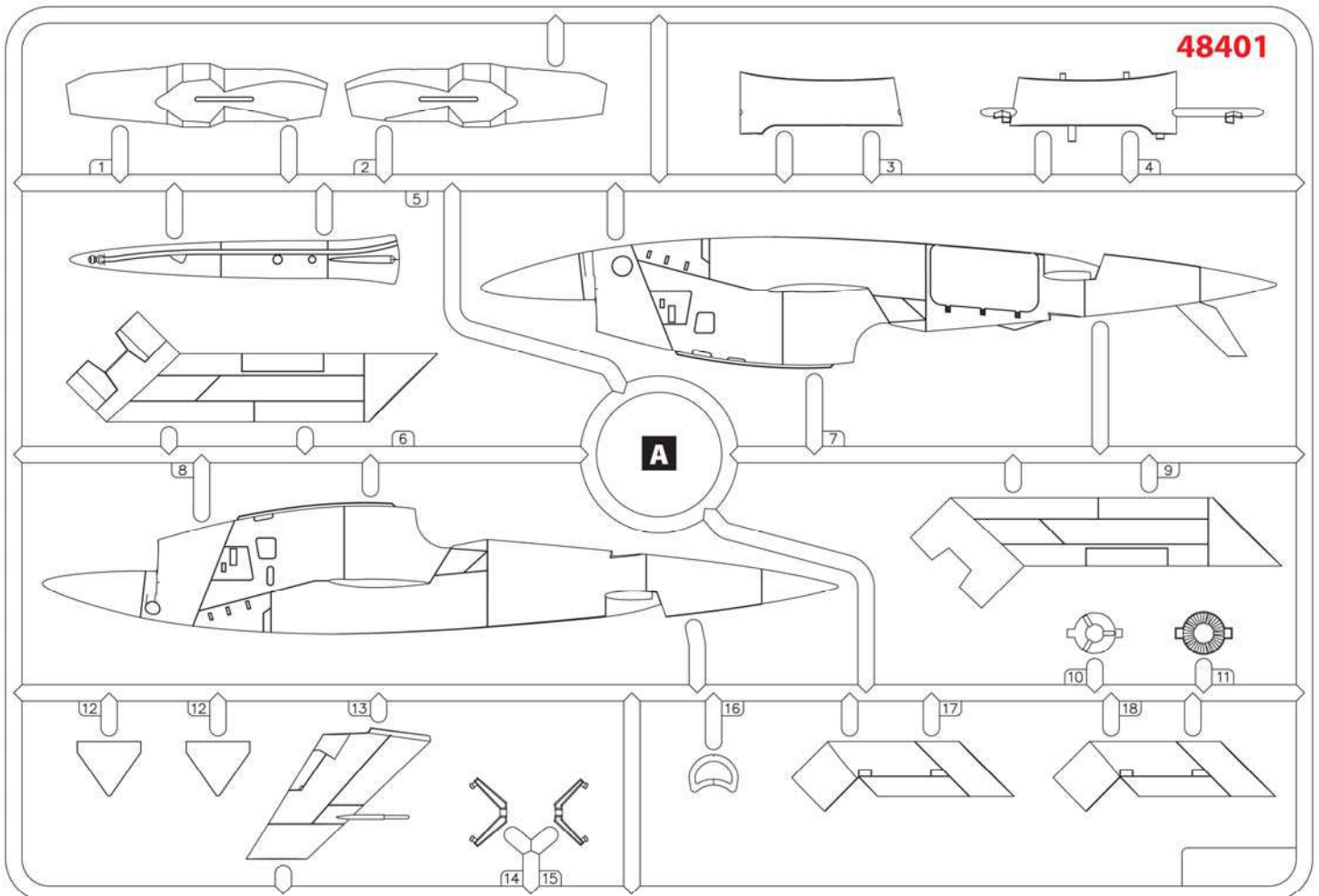
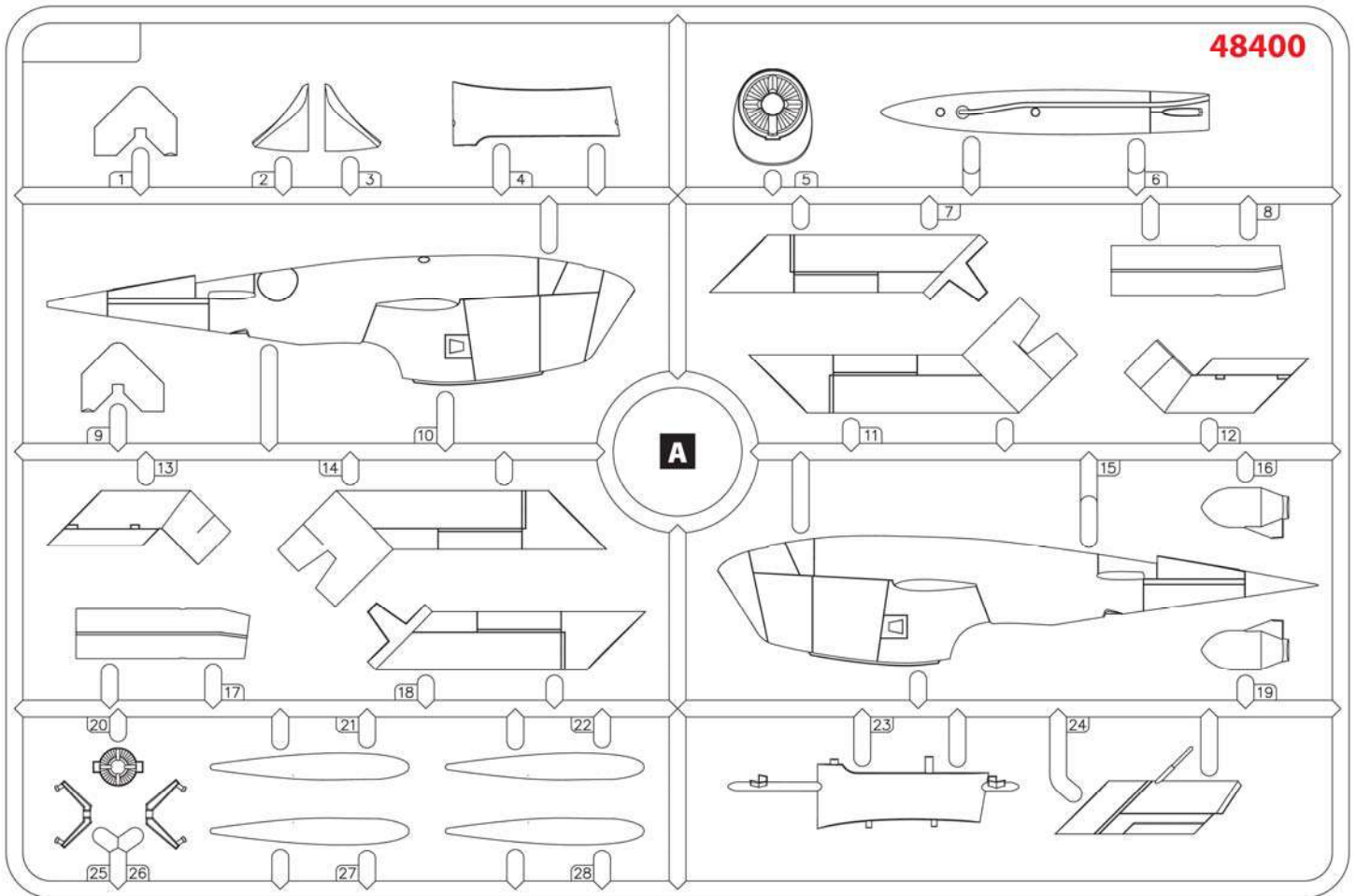

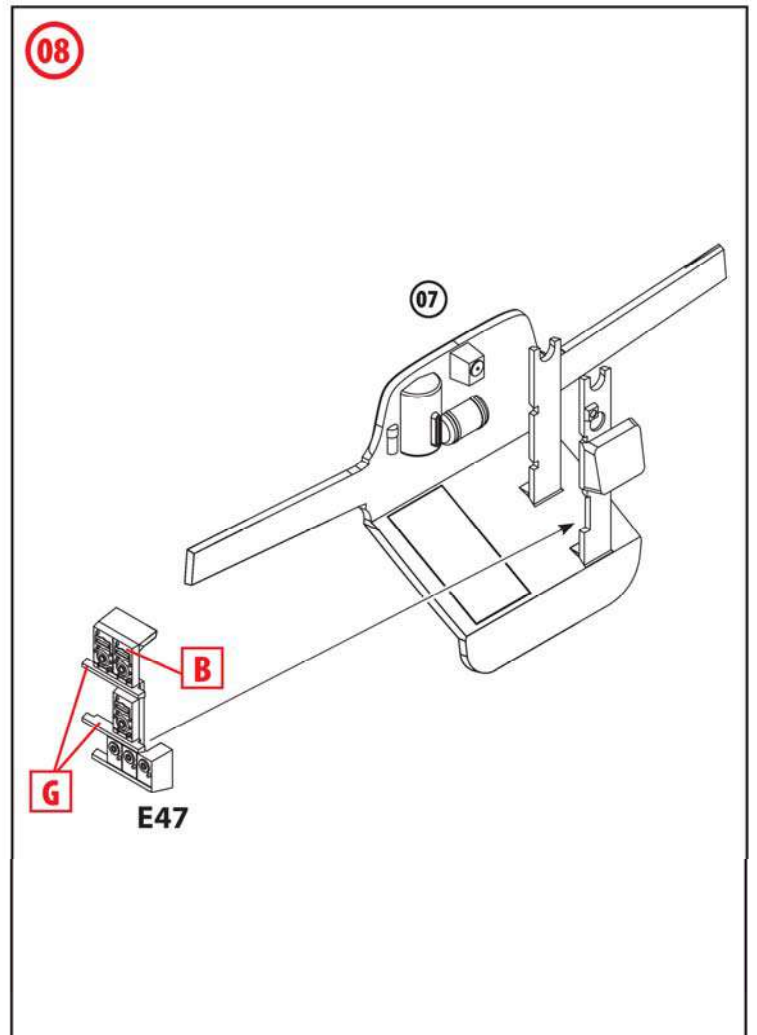
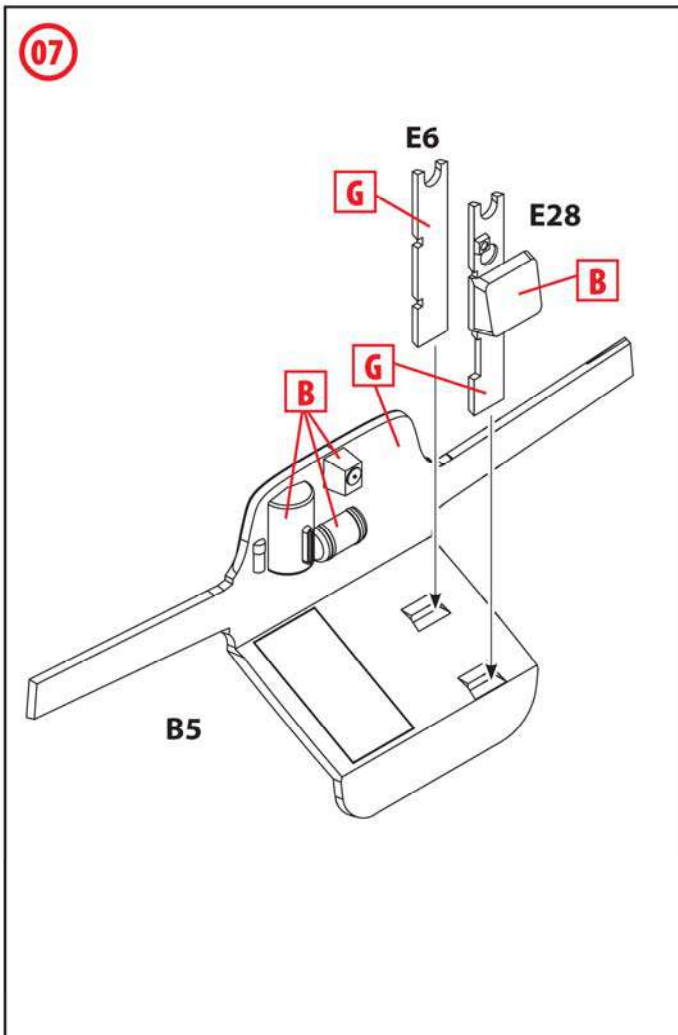
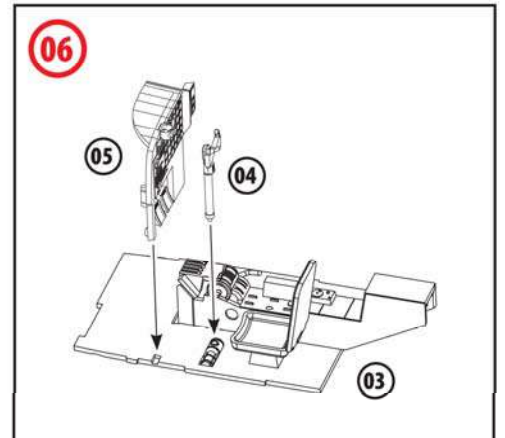
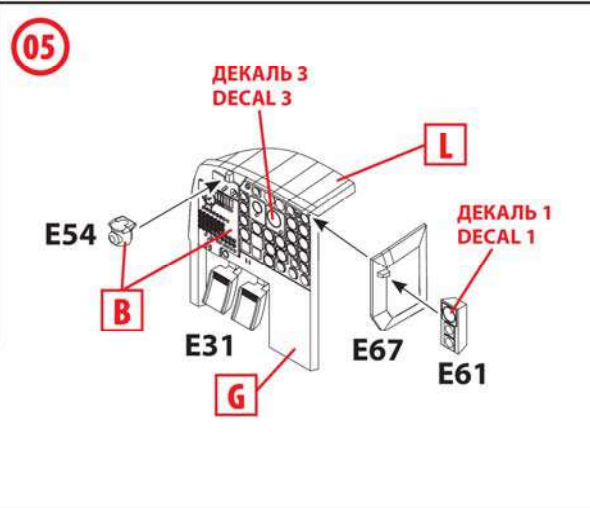
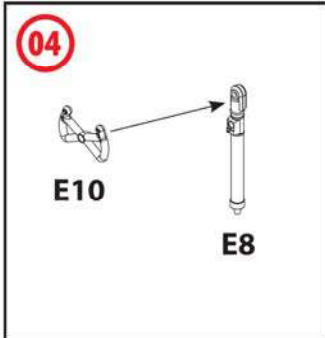
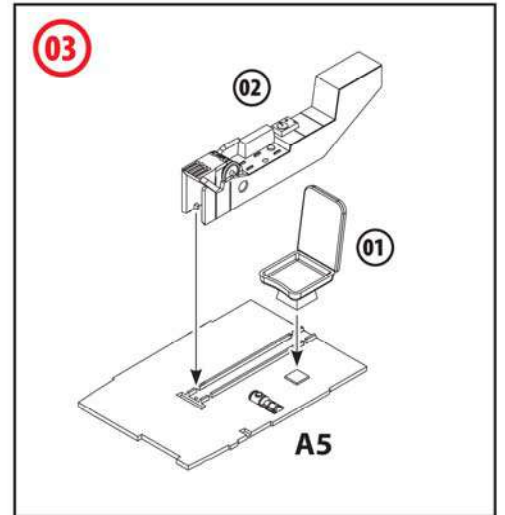
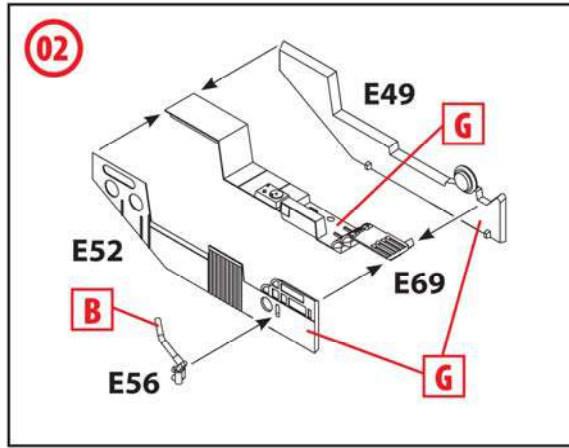
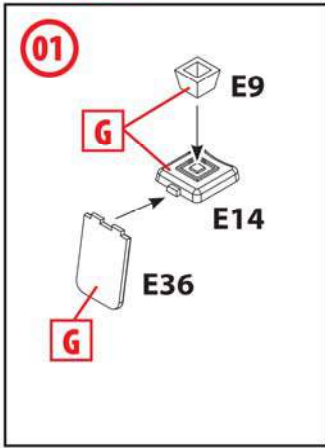

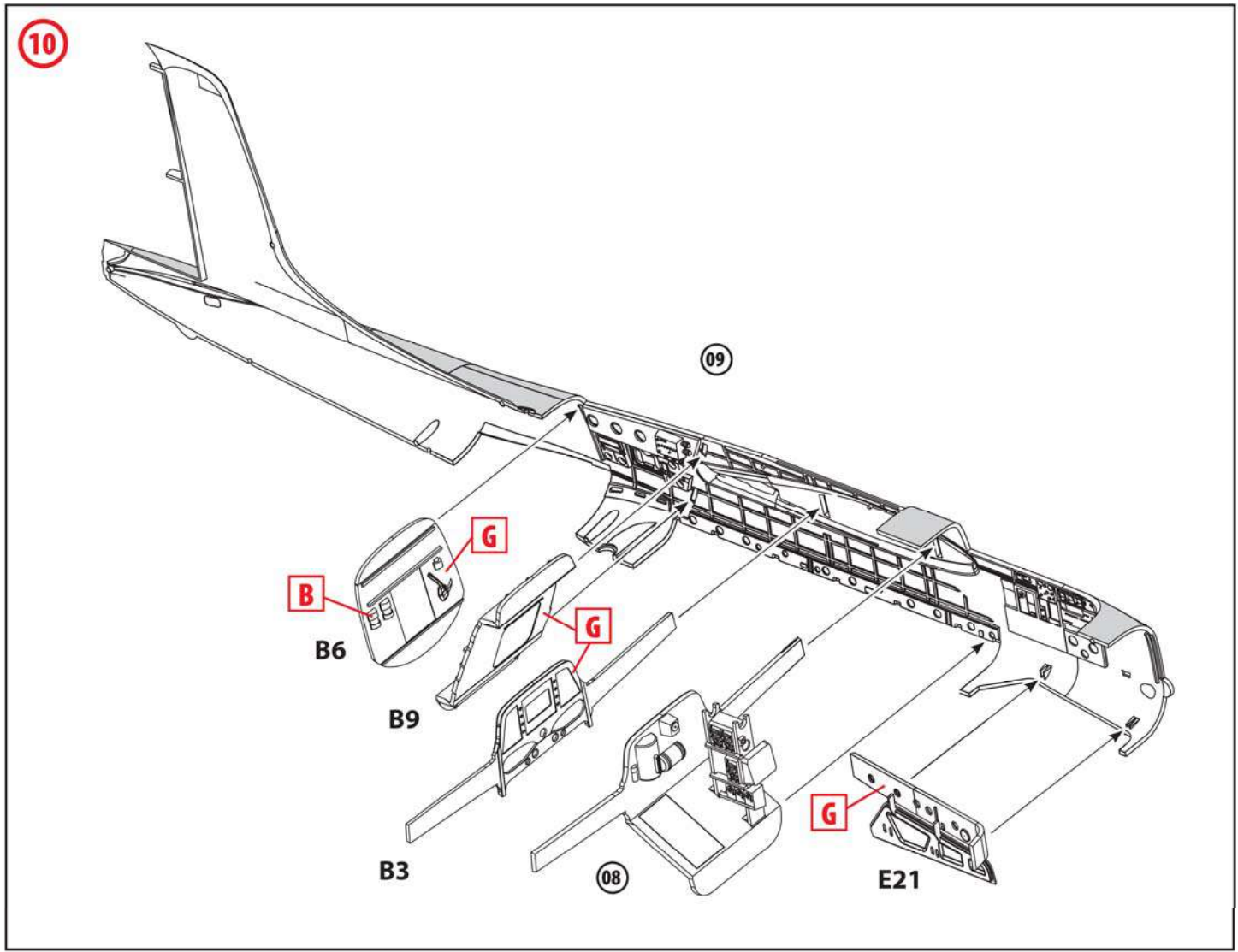
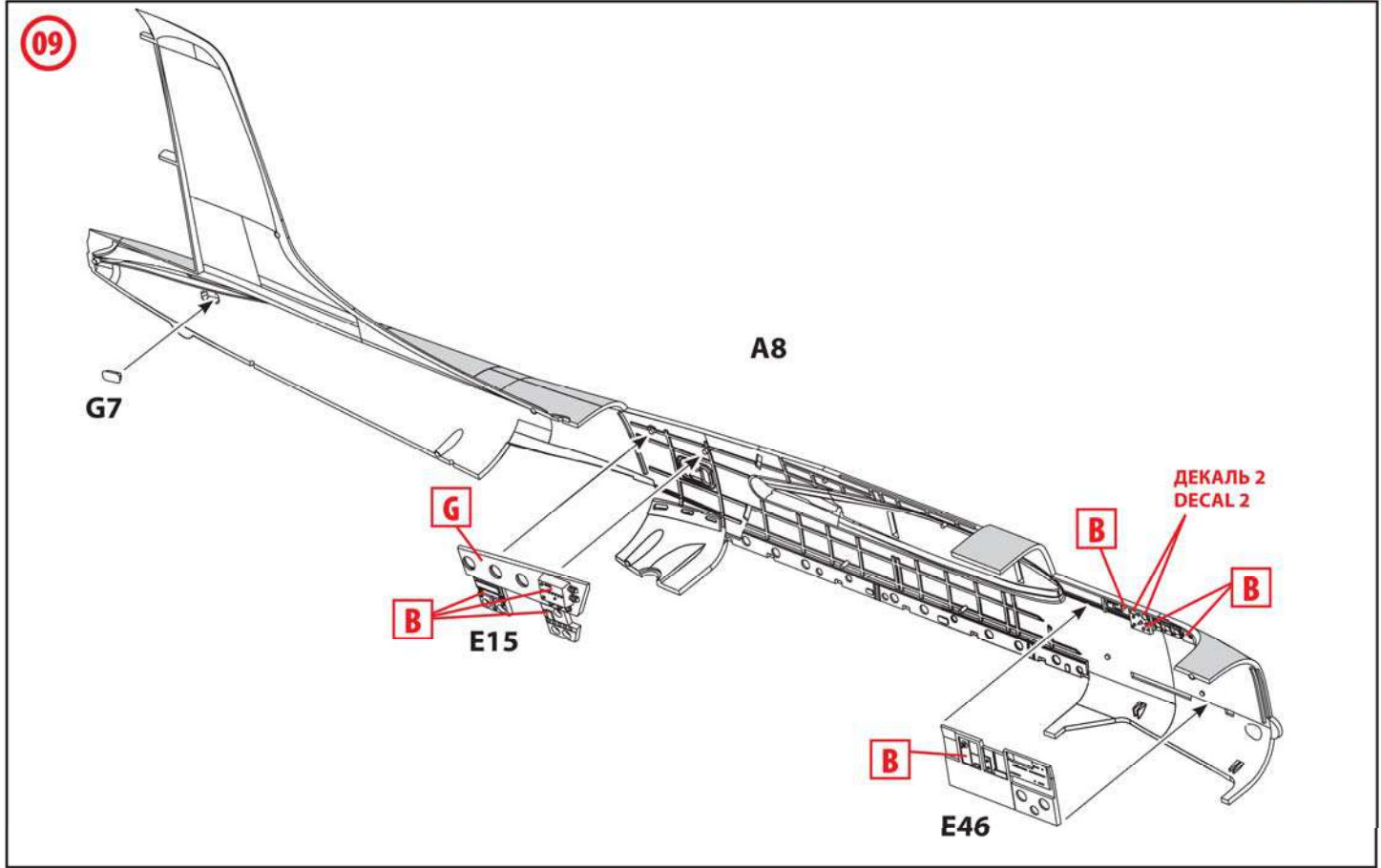

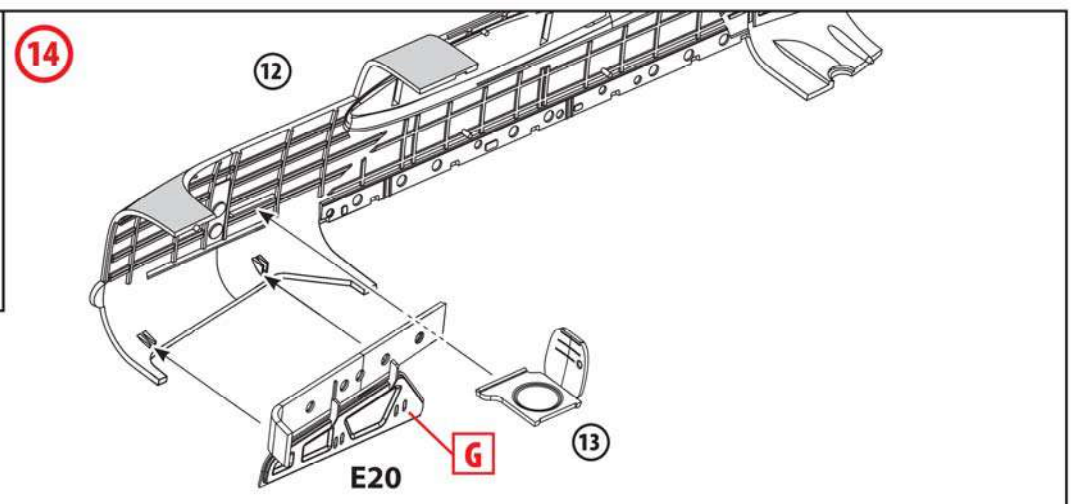
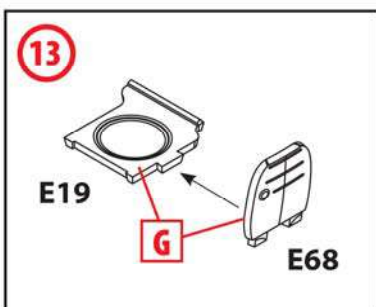
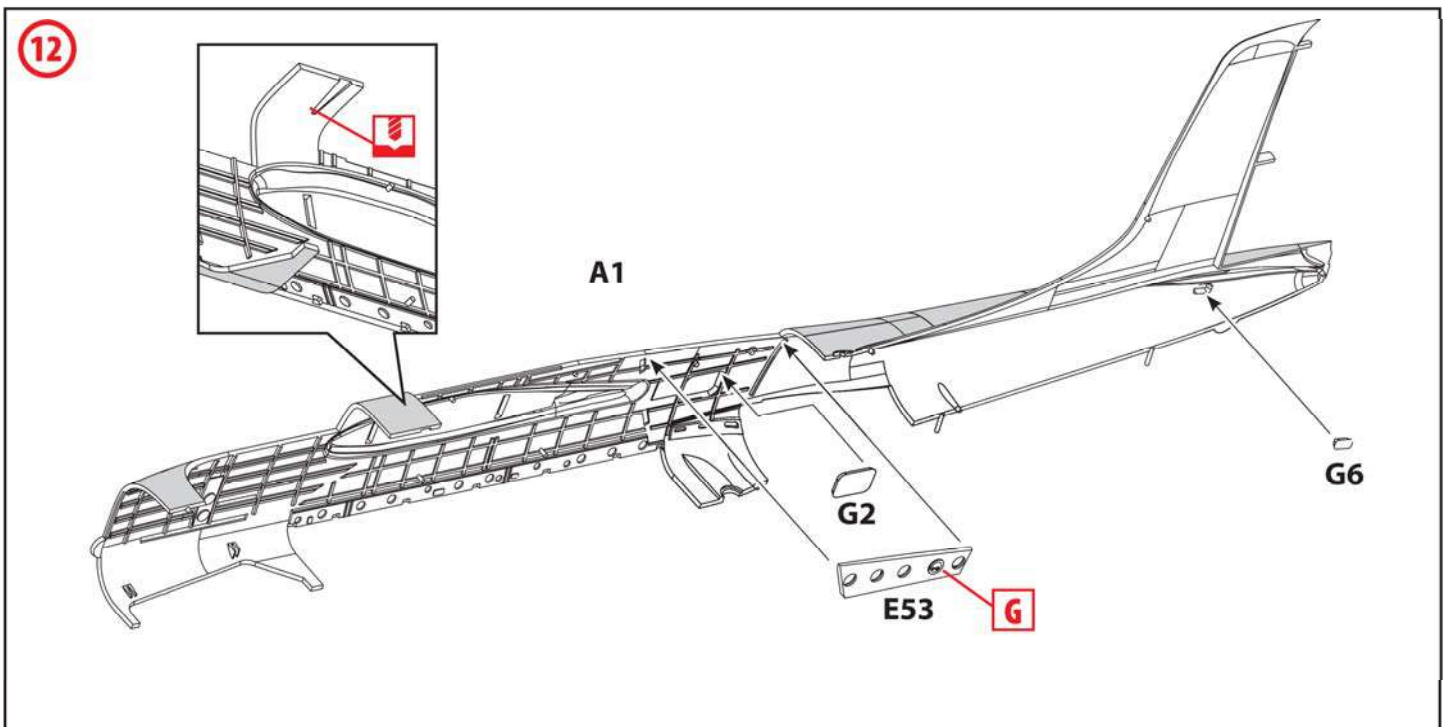
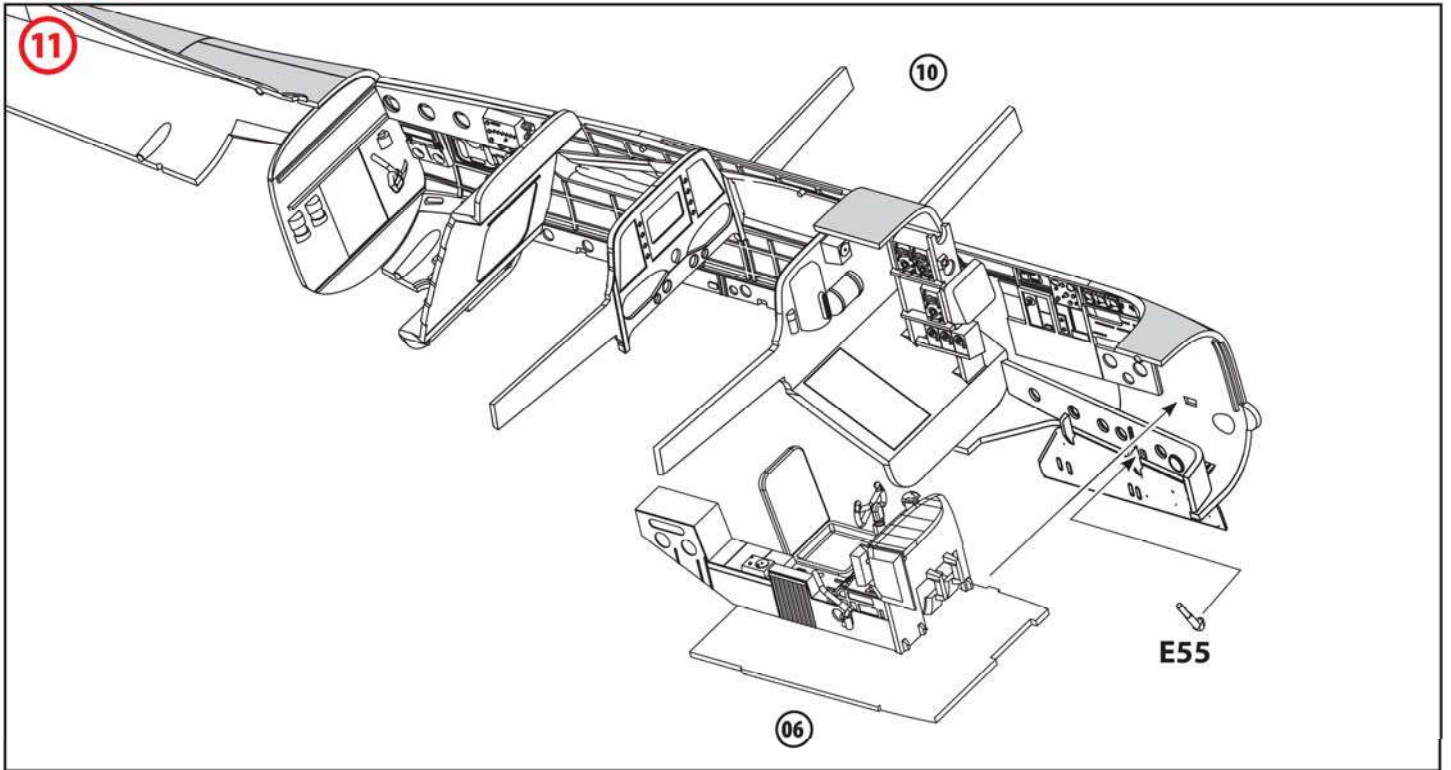

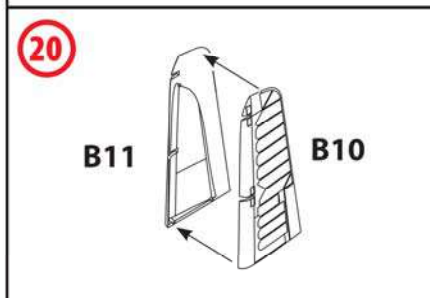
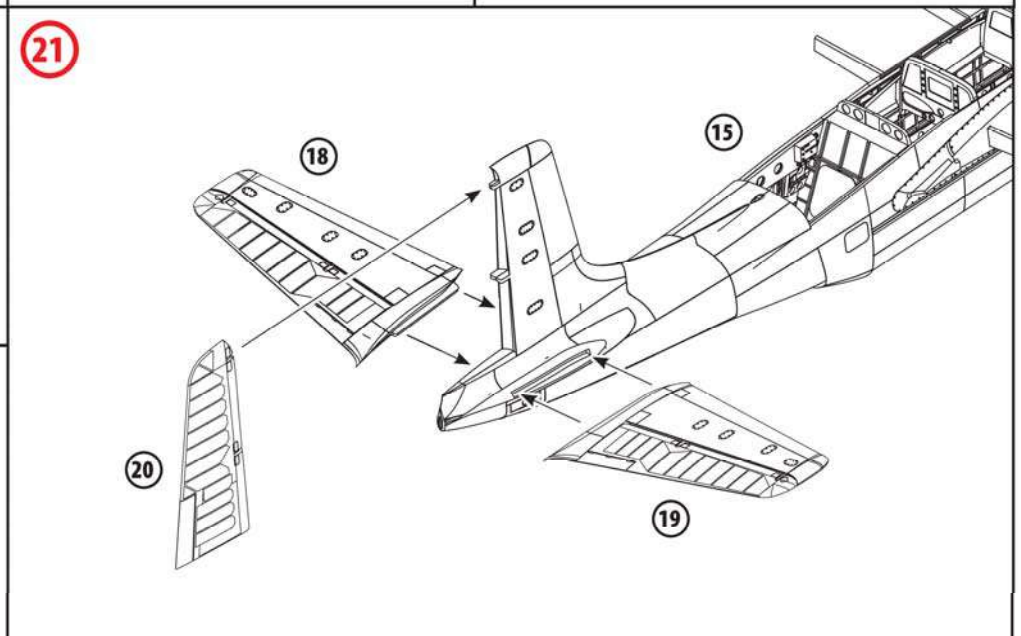
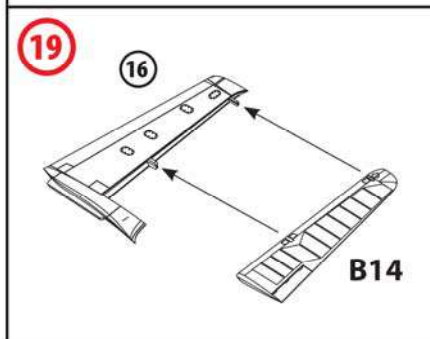
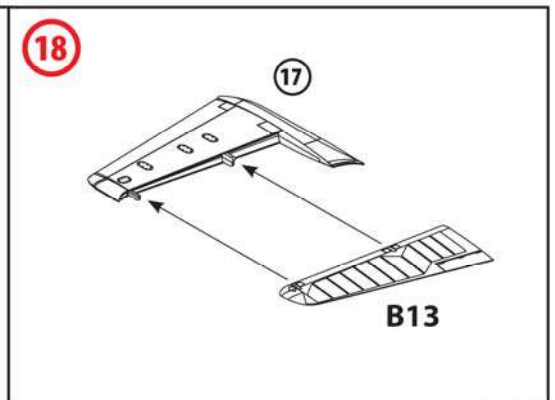
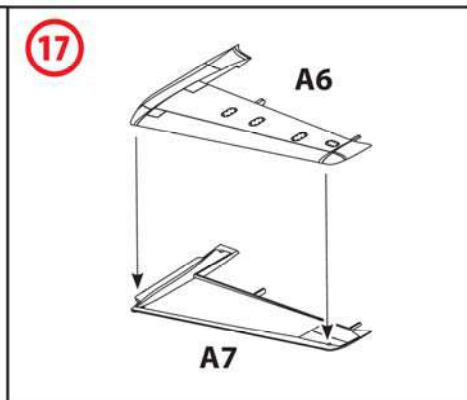
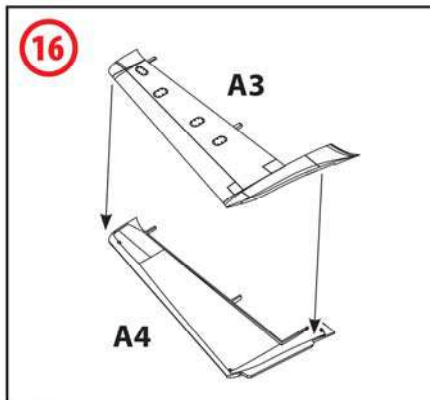
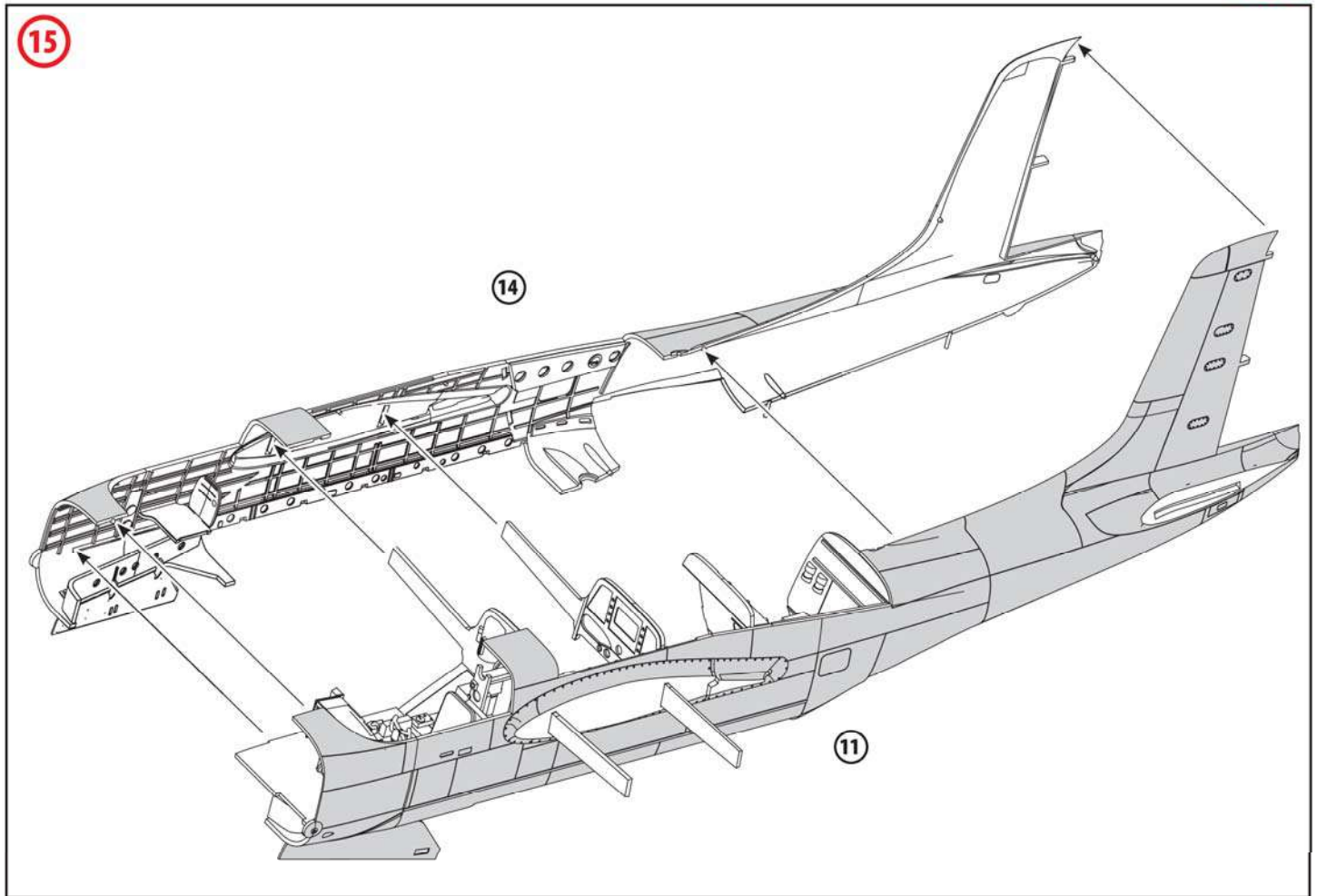

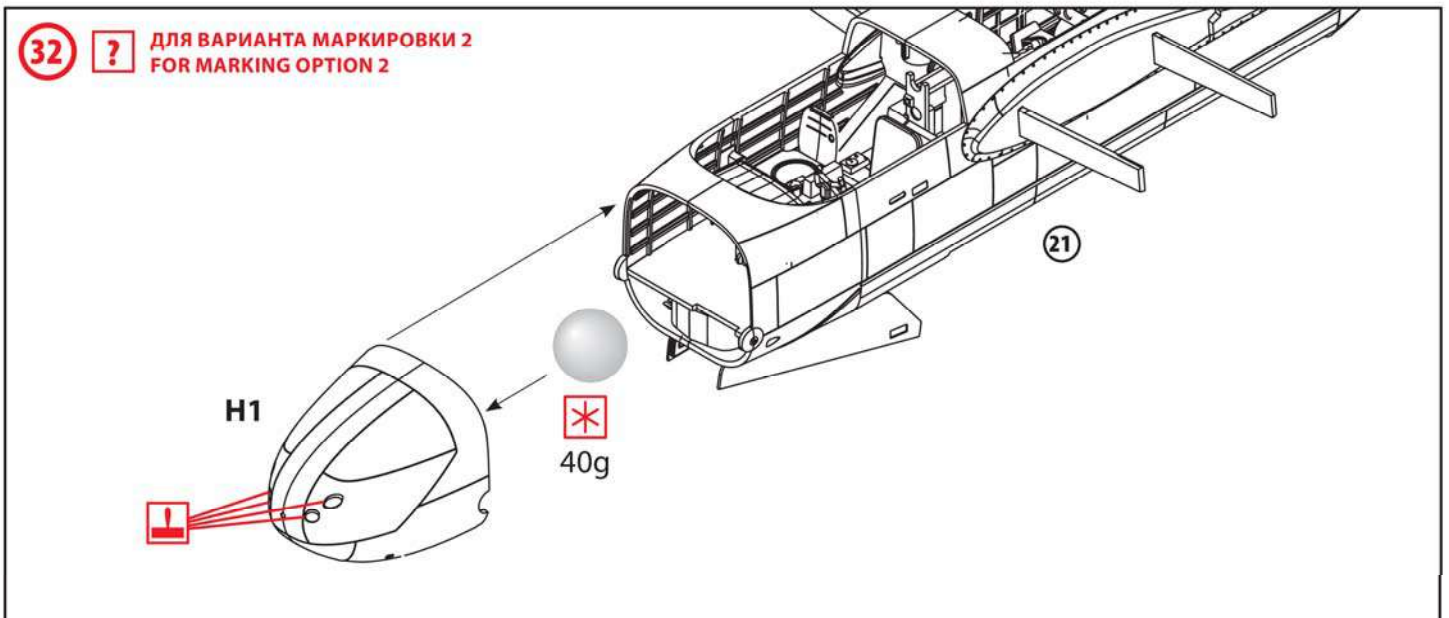
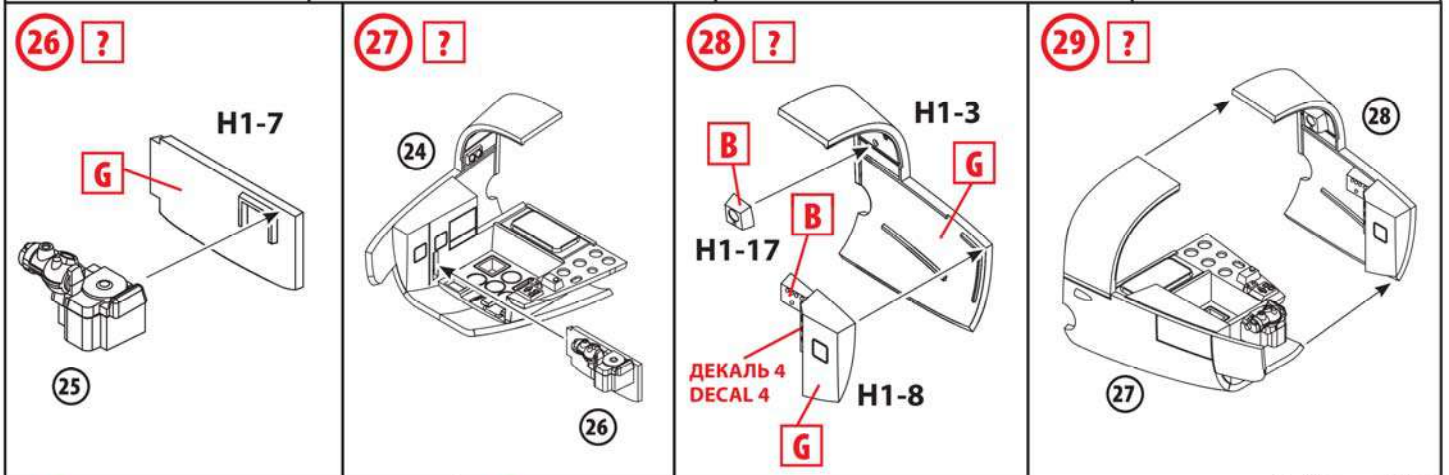
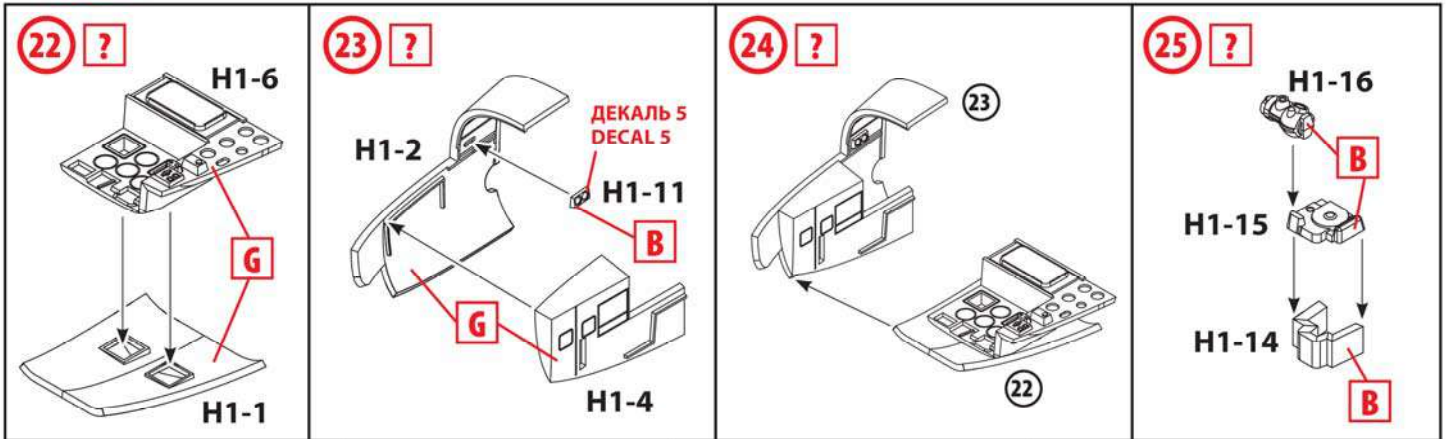

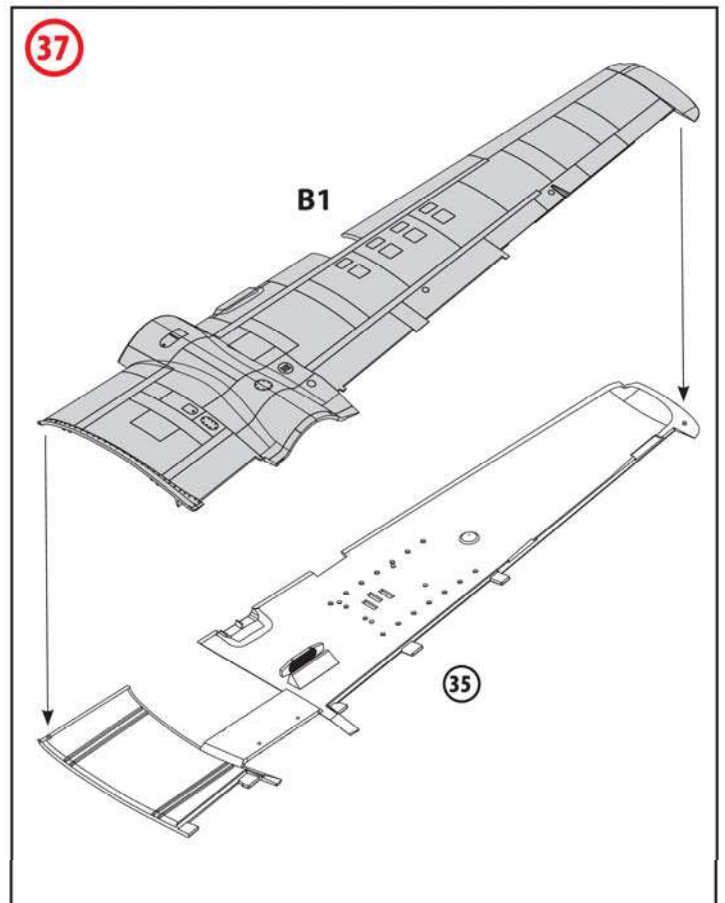
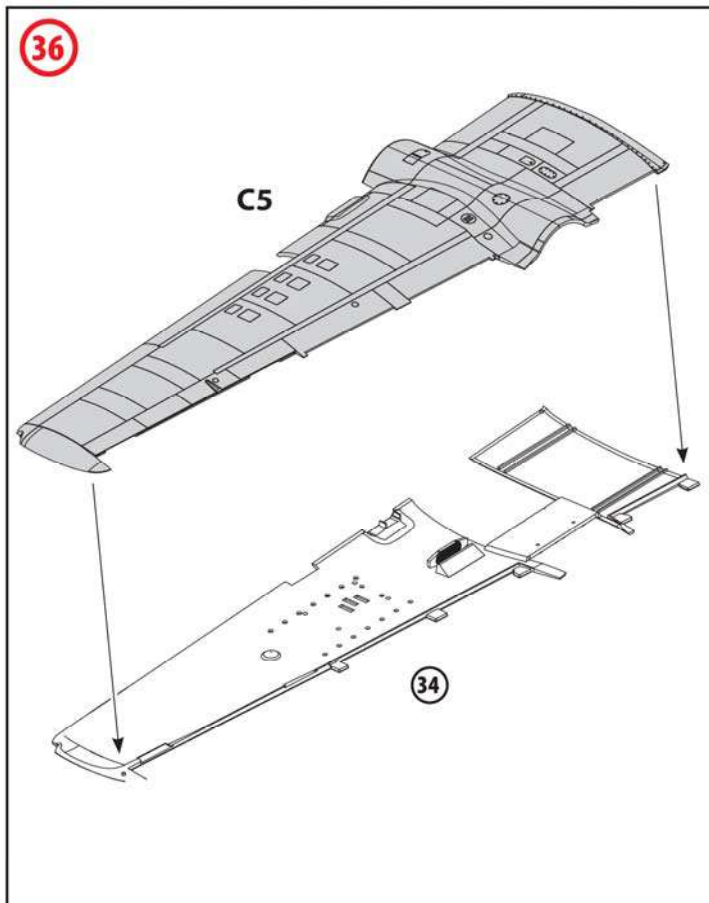
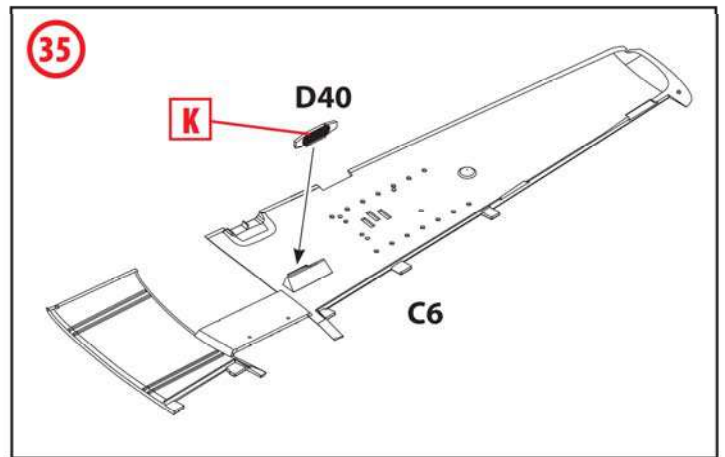
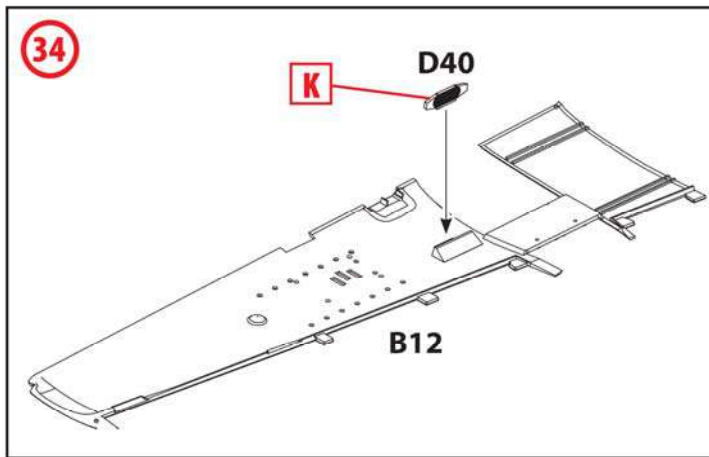
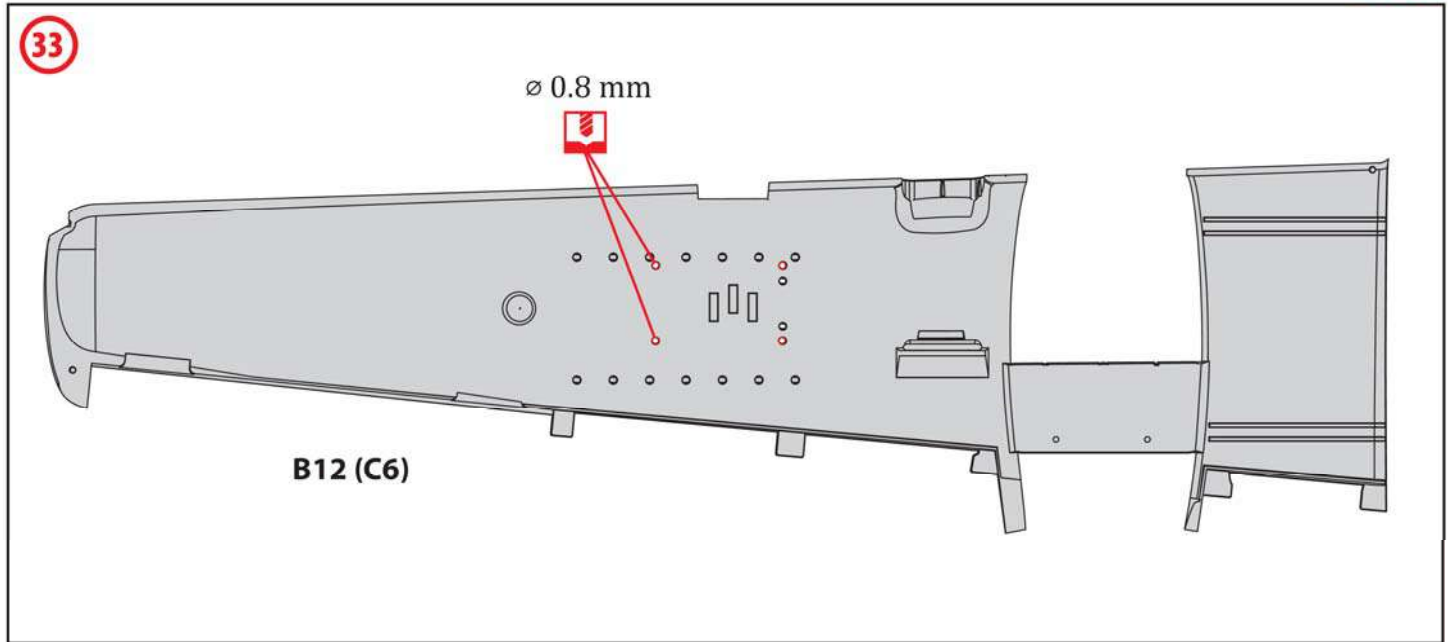

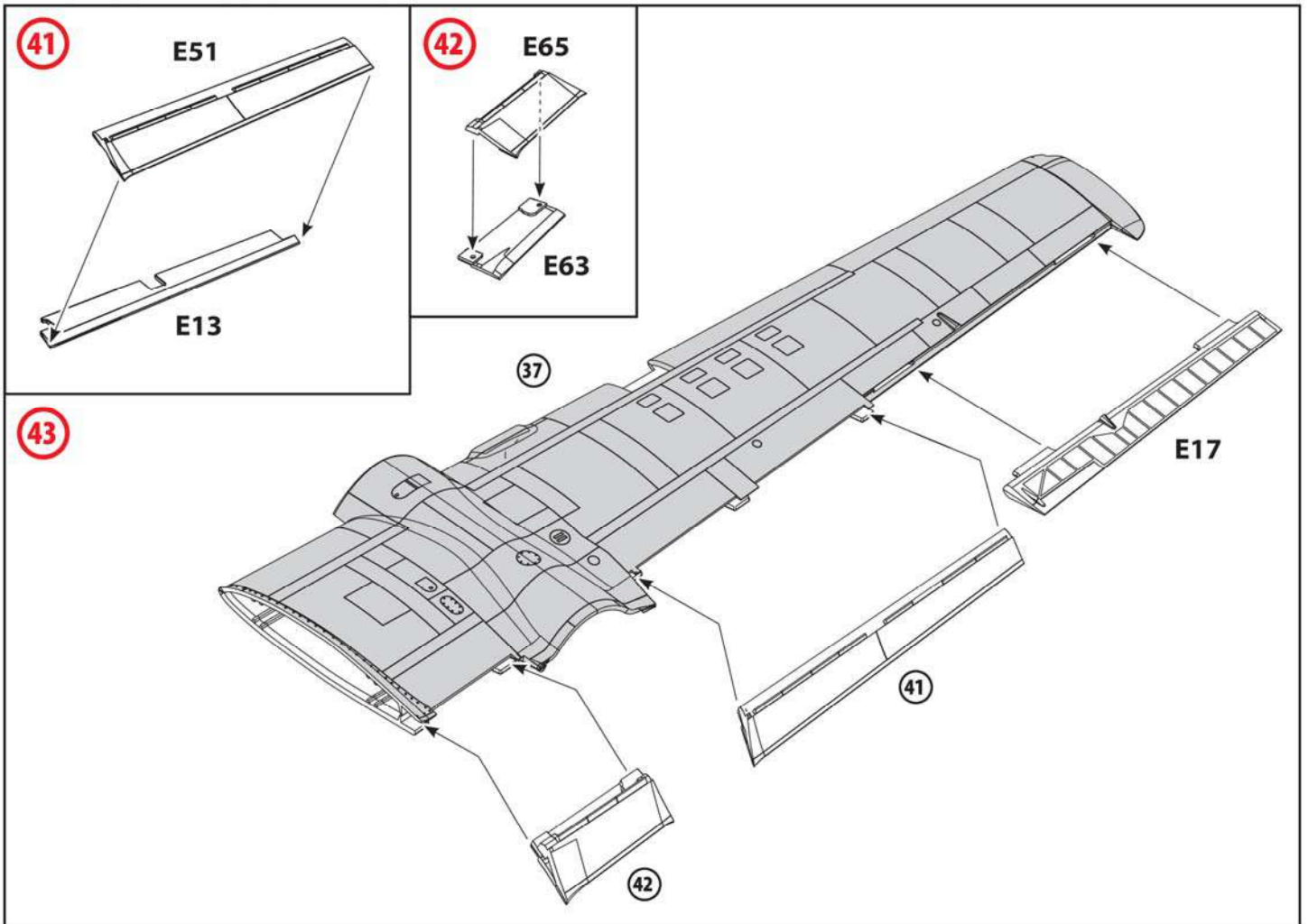
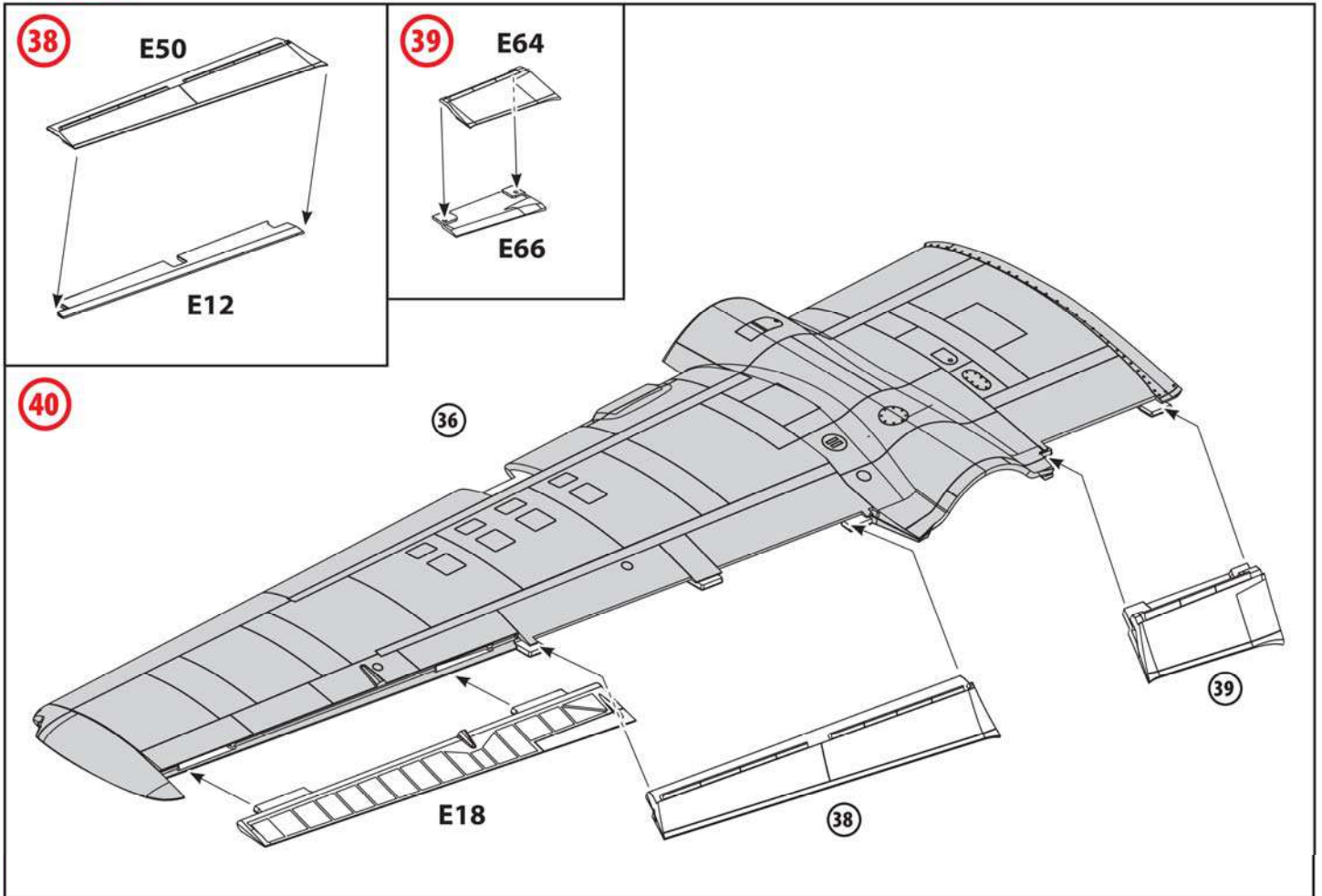

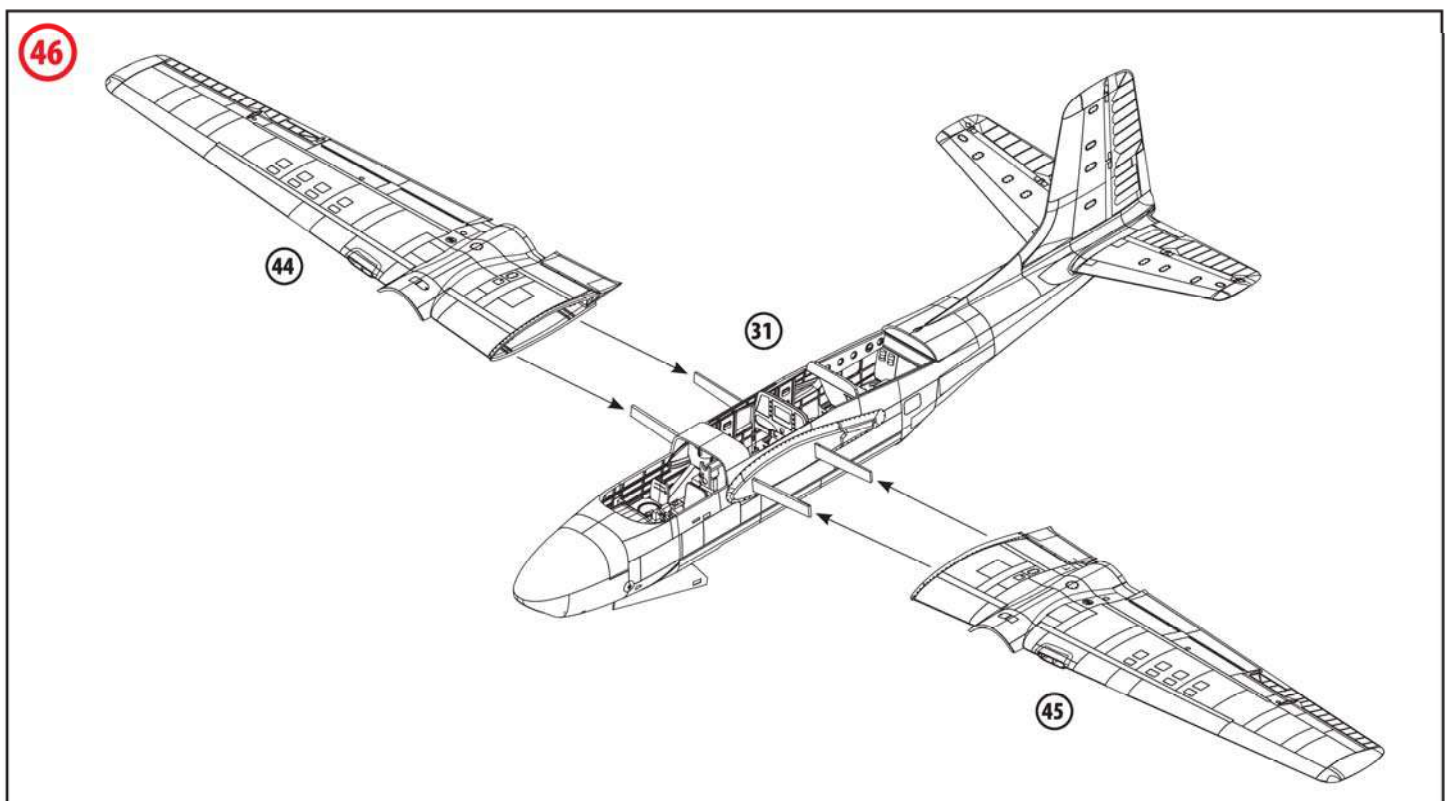
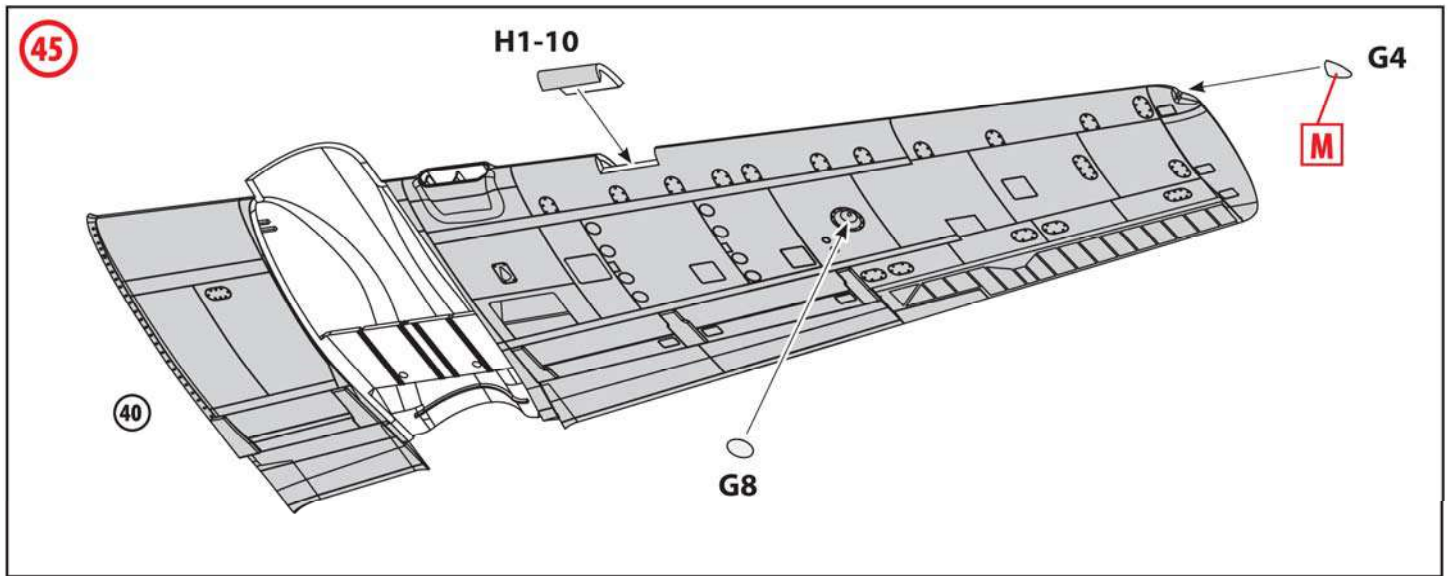
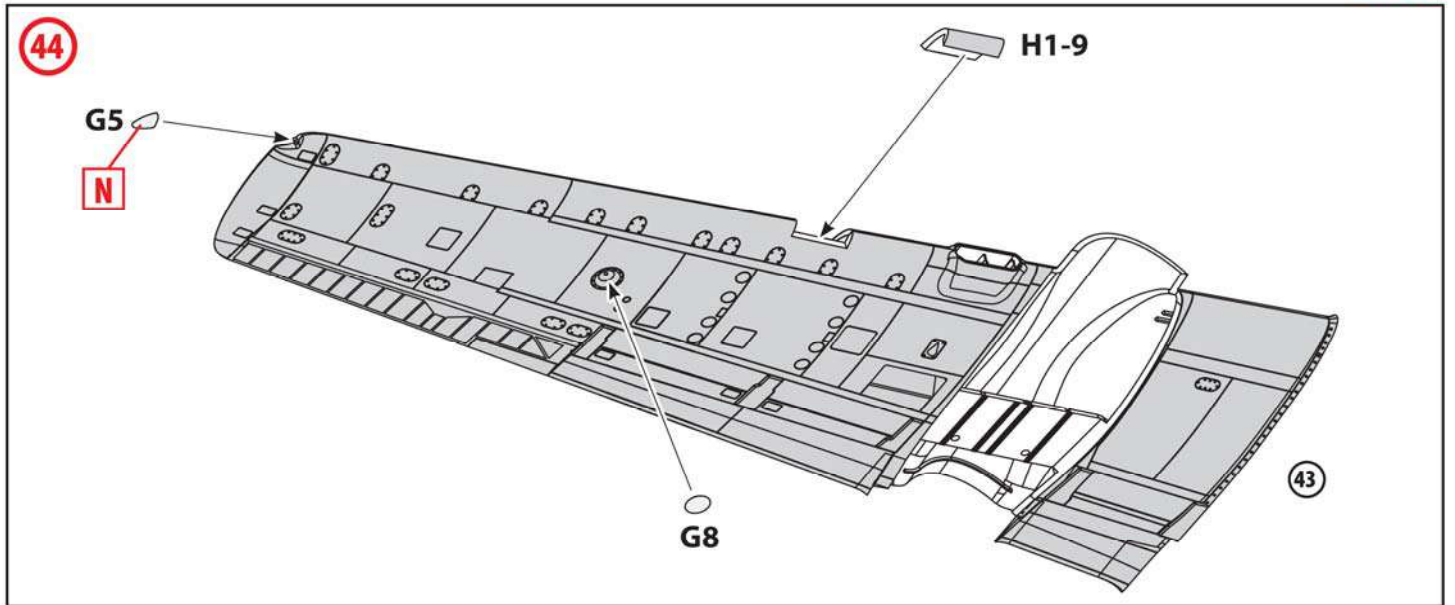

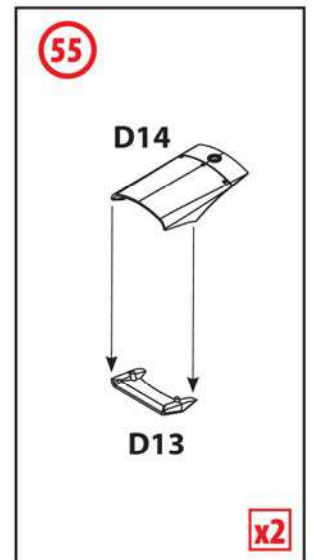
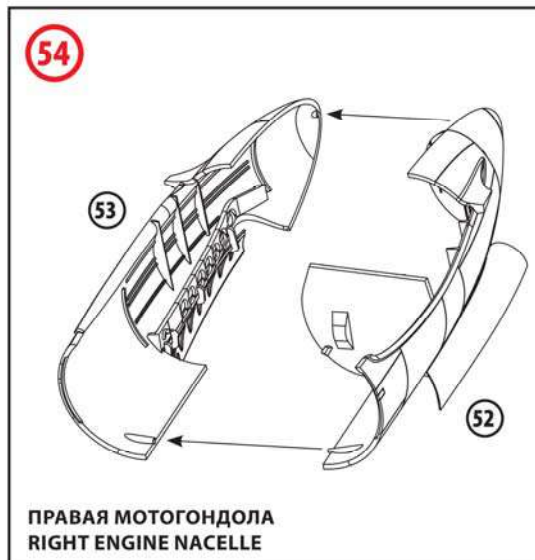
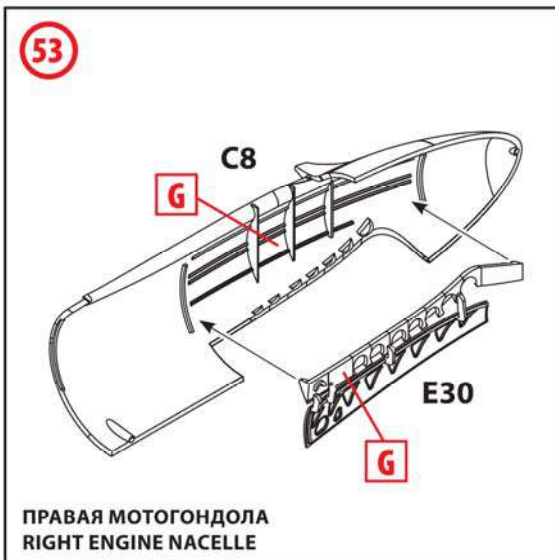
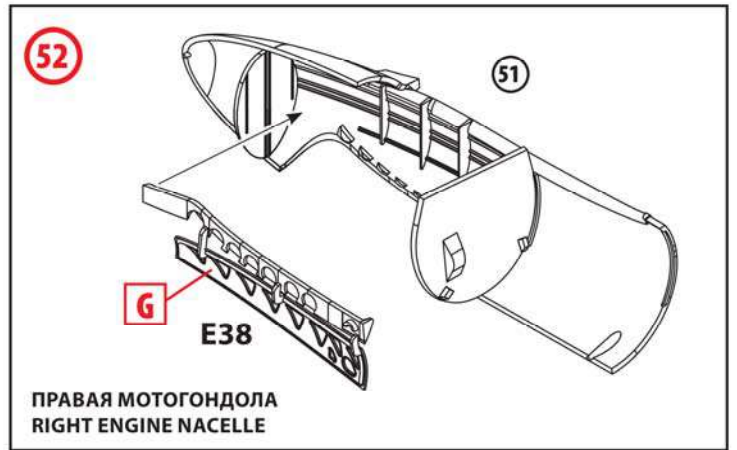
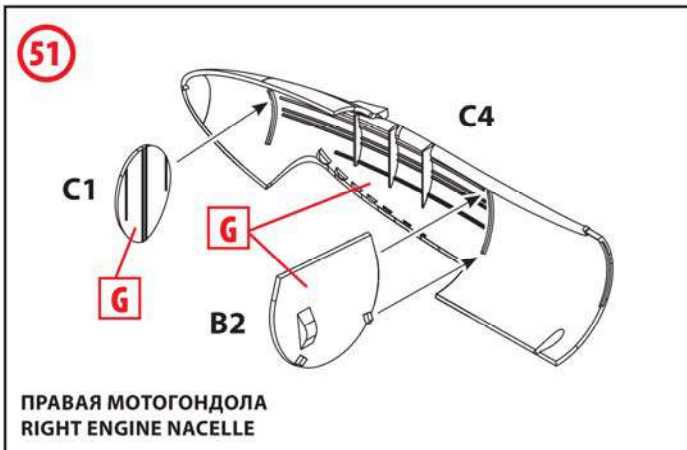
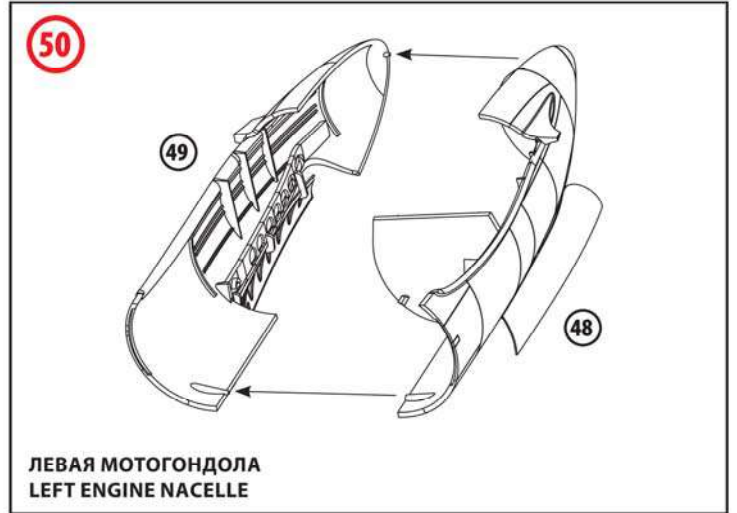
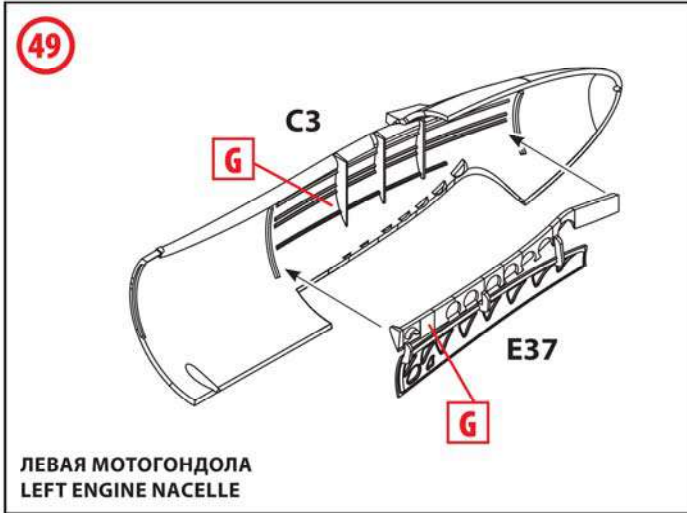
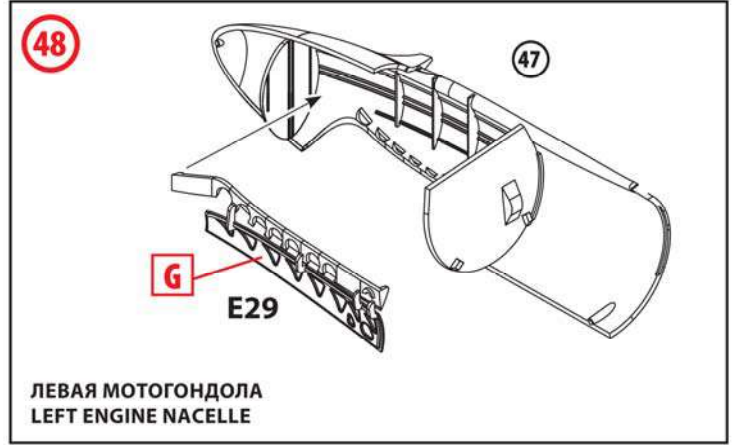
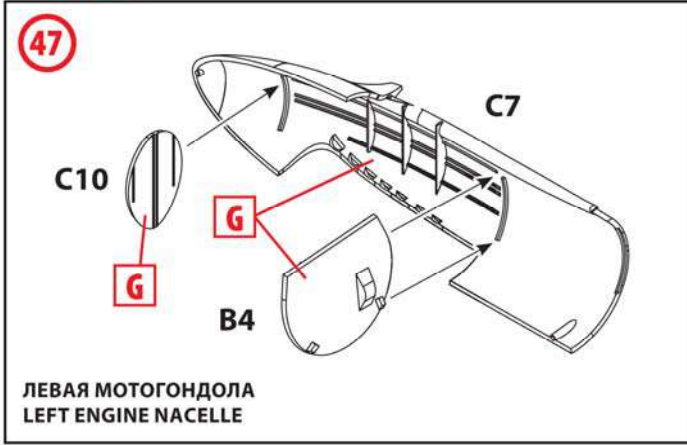

<p>56</p> <p>D17</p> <p>x2</p>	<p>57</p> <p>ПРАВАЯ МОТОГОНДОЛА RIGHT ENGINE NACELLE</p> <p>* 100g ?</p> <p>ДЛЯ ВАРИАНТА МАРКИРОВКИ 1 FOR MARKING OPTION 1</p>	<p>58</p> <p>ЛЕВАЯ МОТОГОНДОЛА LEFT ENGINE NACELLE</p> <p>* 100g ?</p> <p>ДЛЯ ВАРИАНТА МАРКИРОВКИ 1 FOR MARKING OPTION 1</p>
--	---	---

59

<p>60</p> <p>A9</p> <p>G</p> <p>B8</p>	<p>61</p> <p>60</p> <p>59</p>
--	--------------------------------------

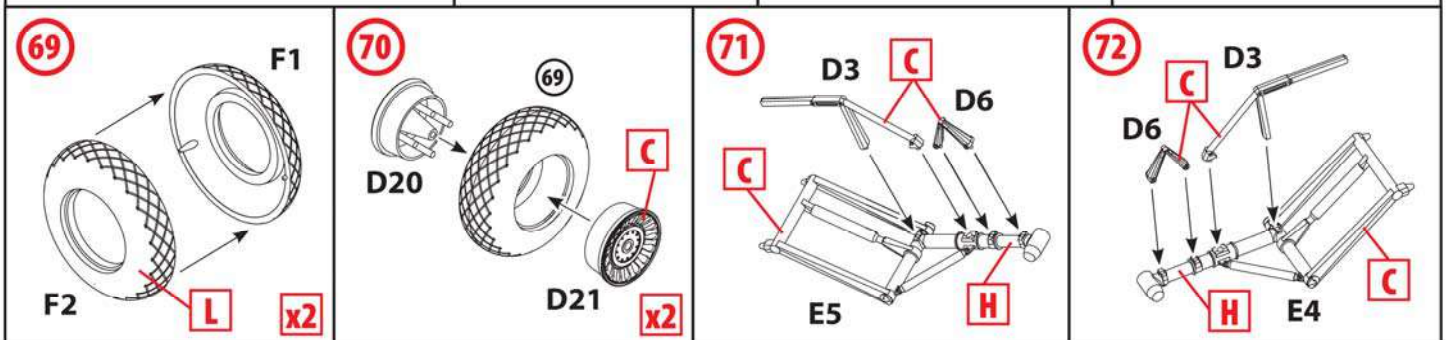
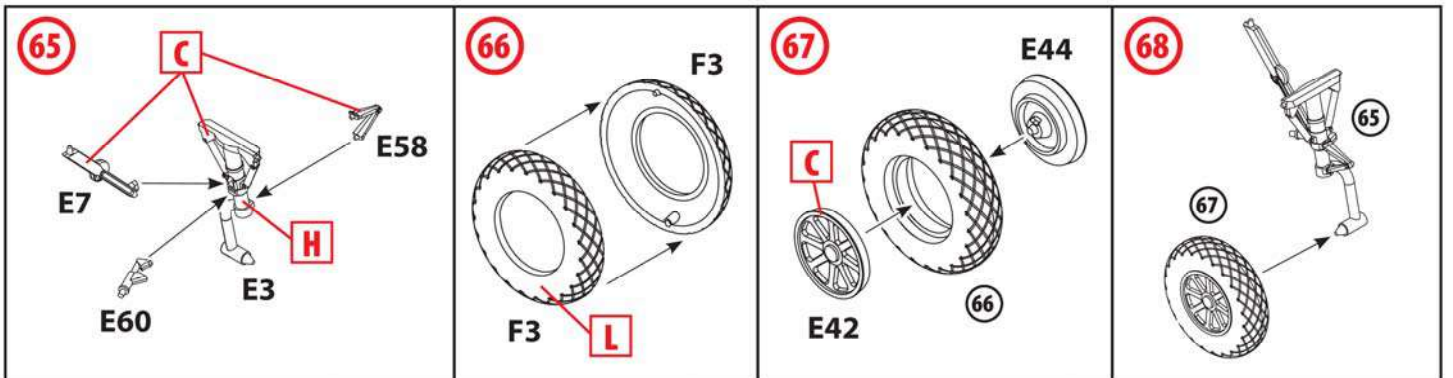
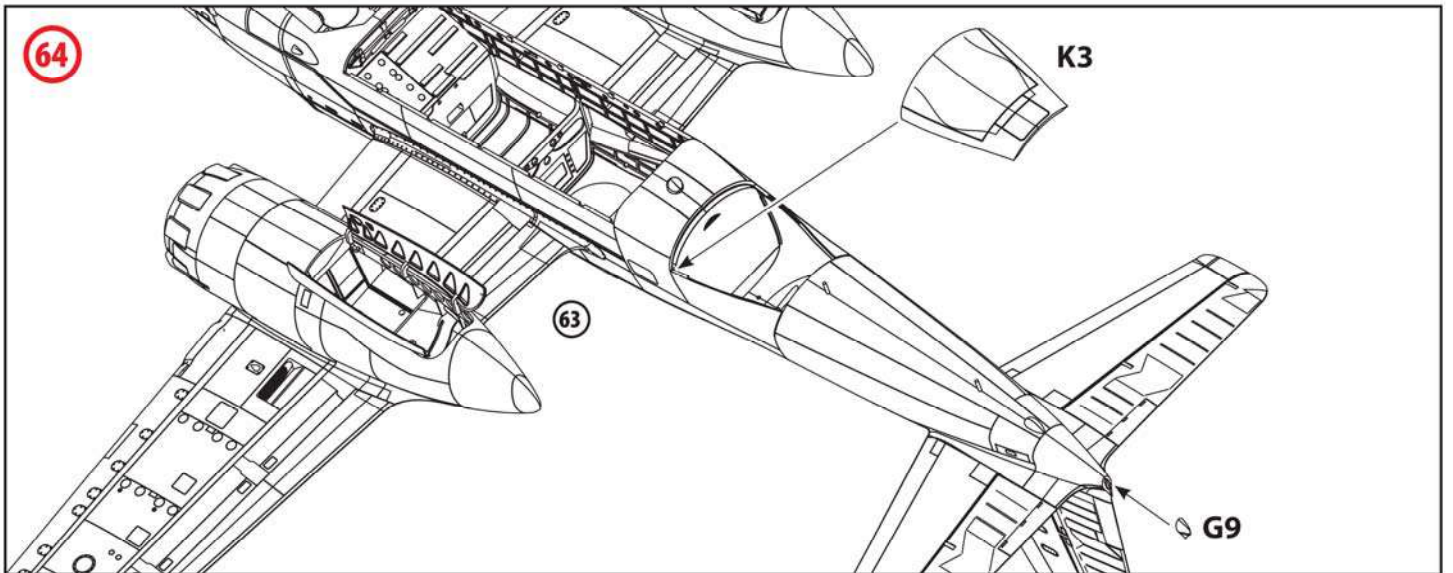
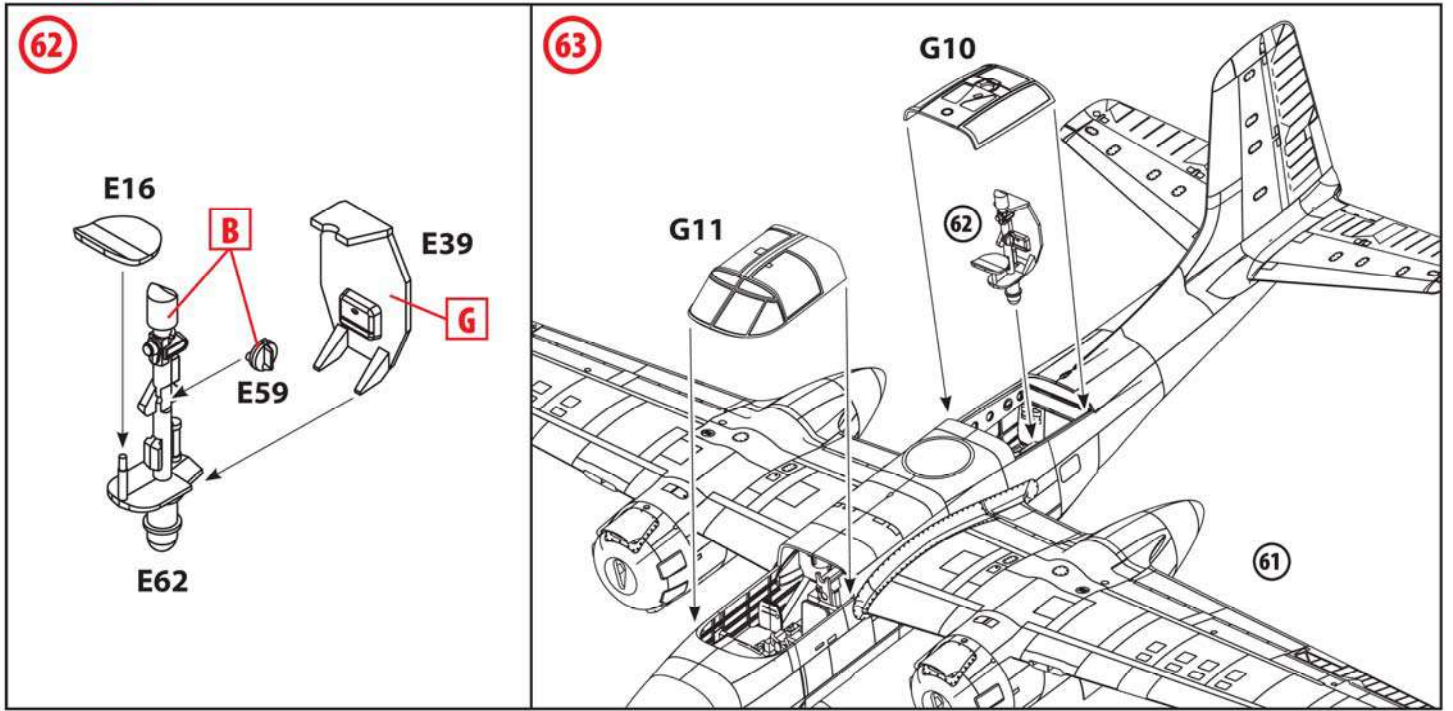

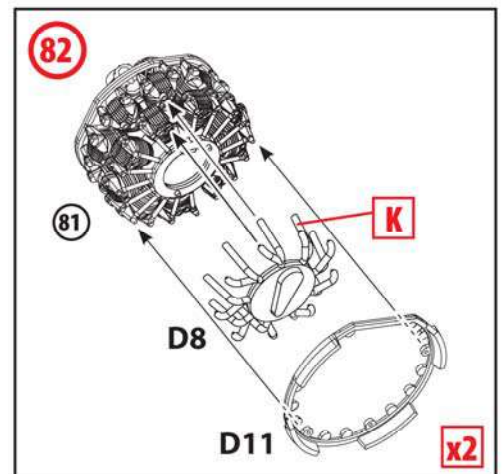
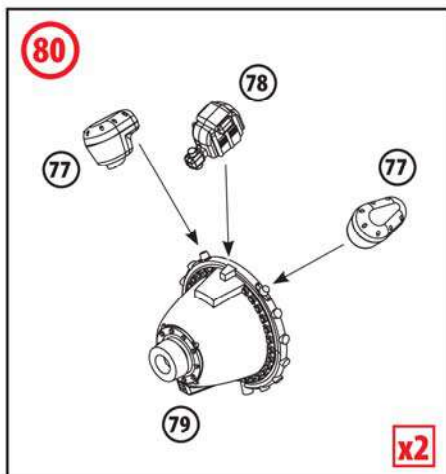
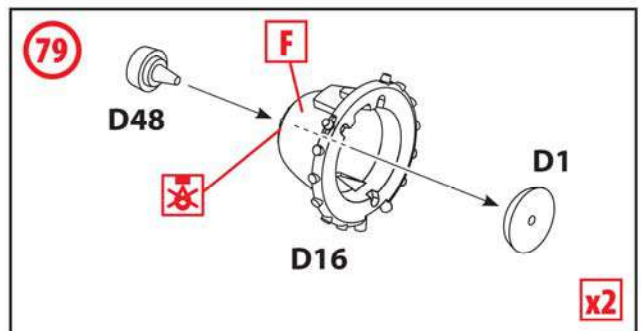
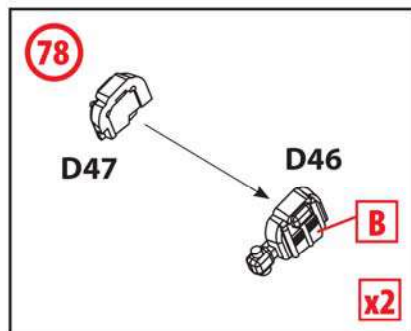
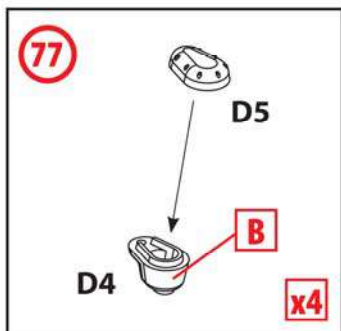
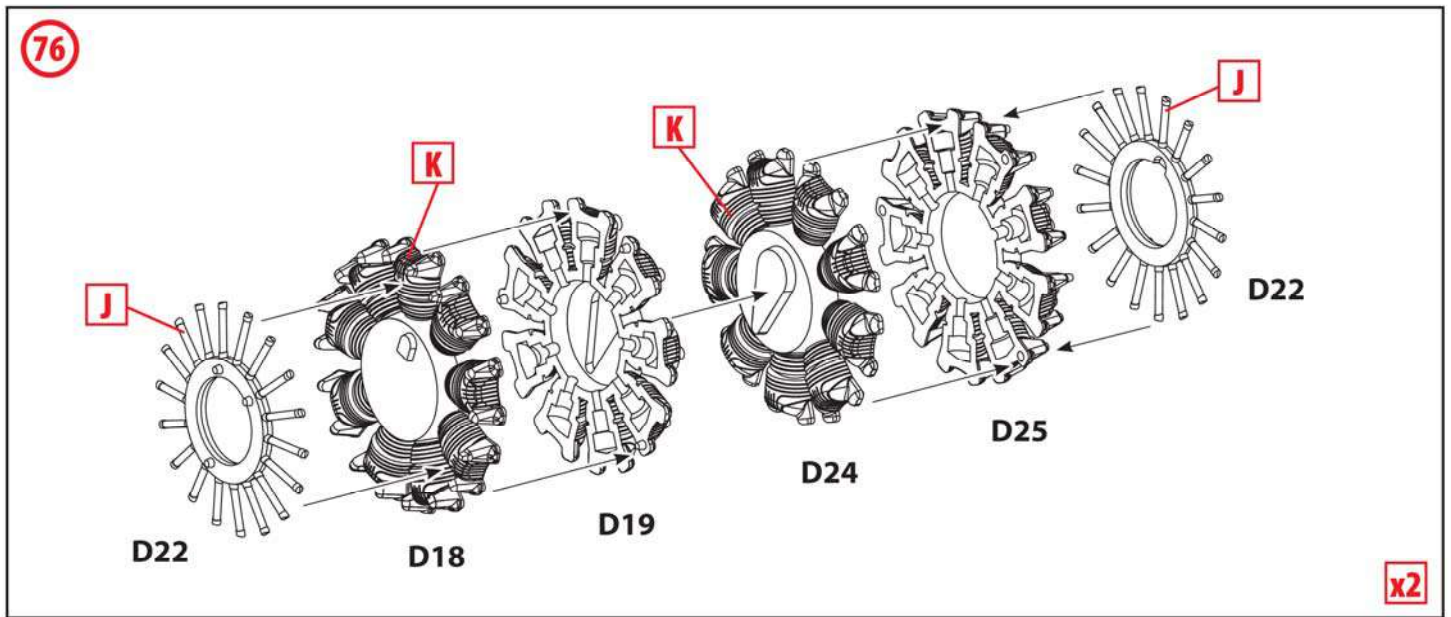
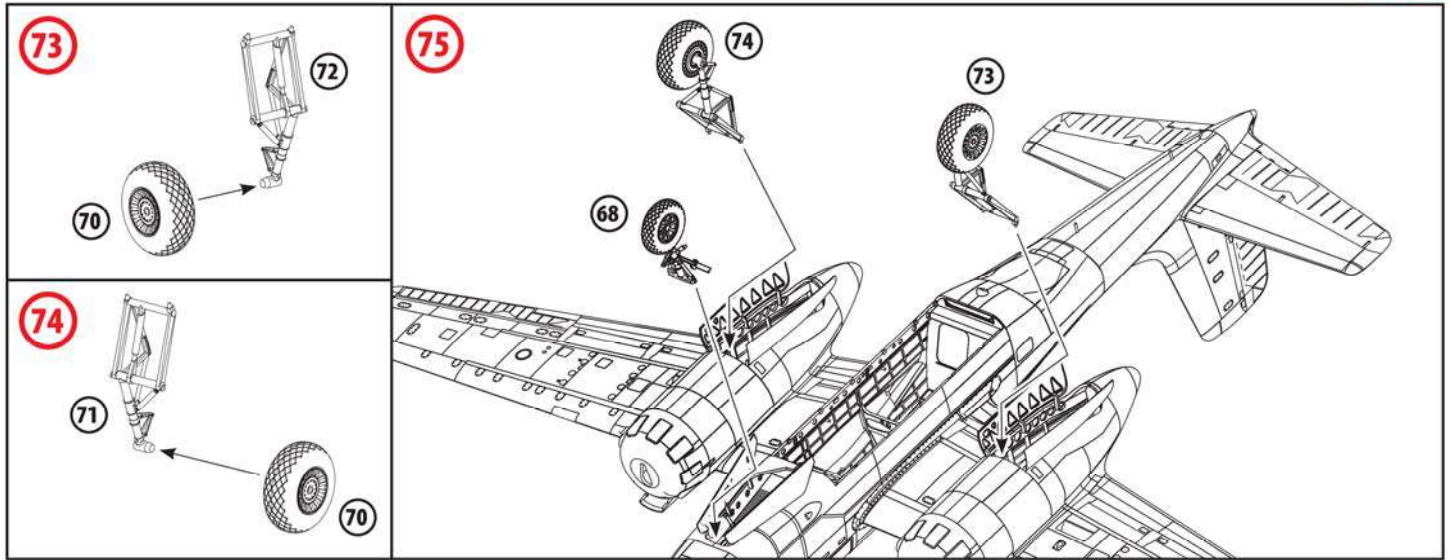

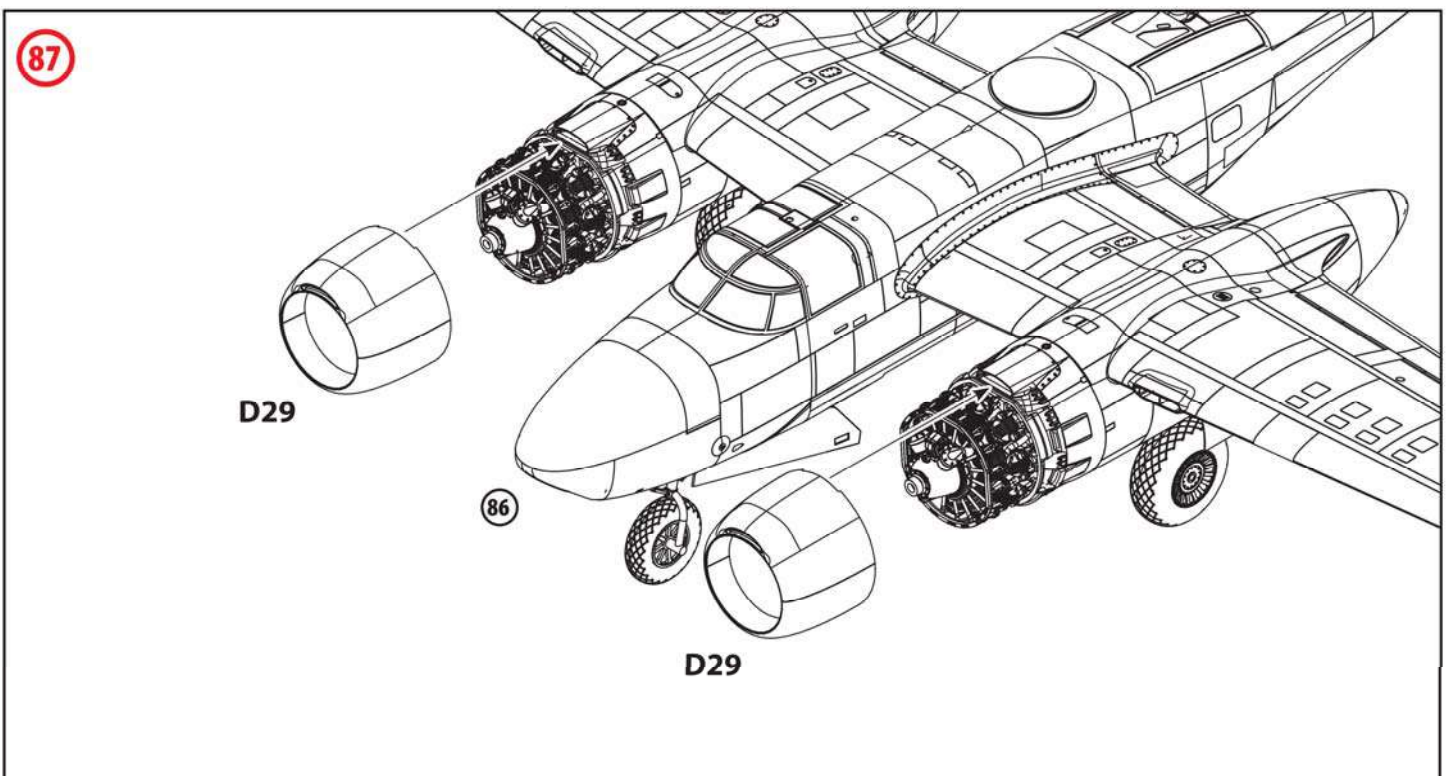
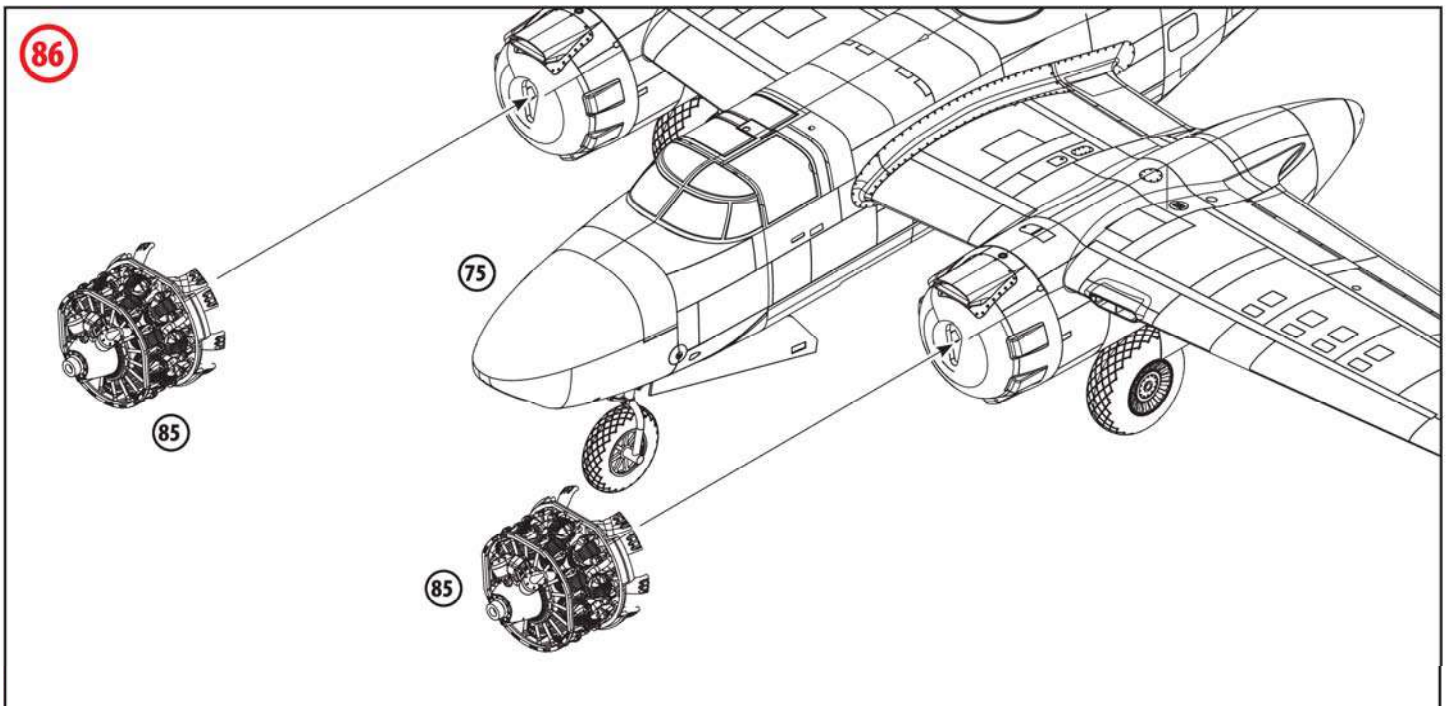
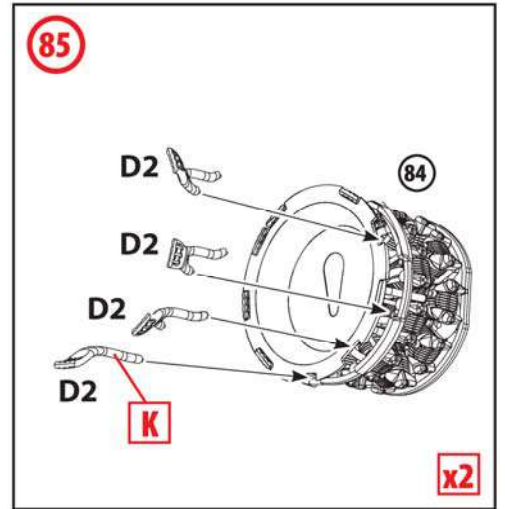
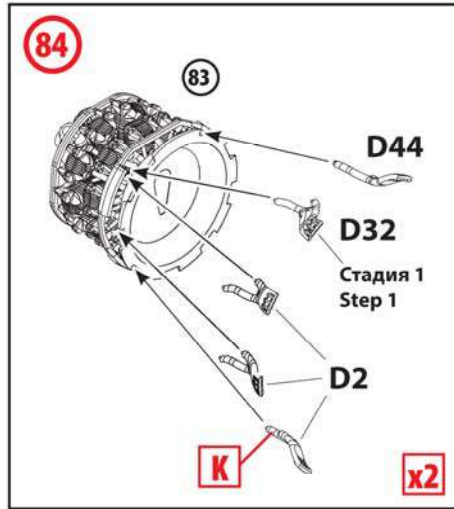
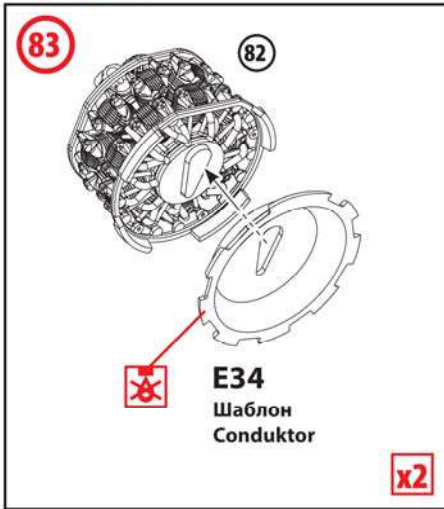

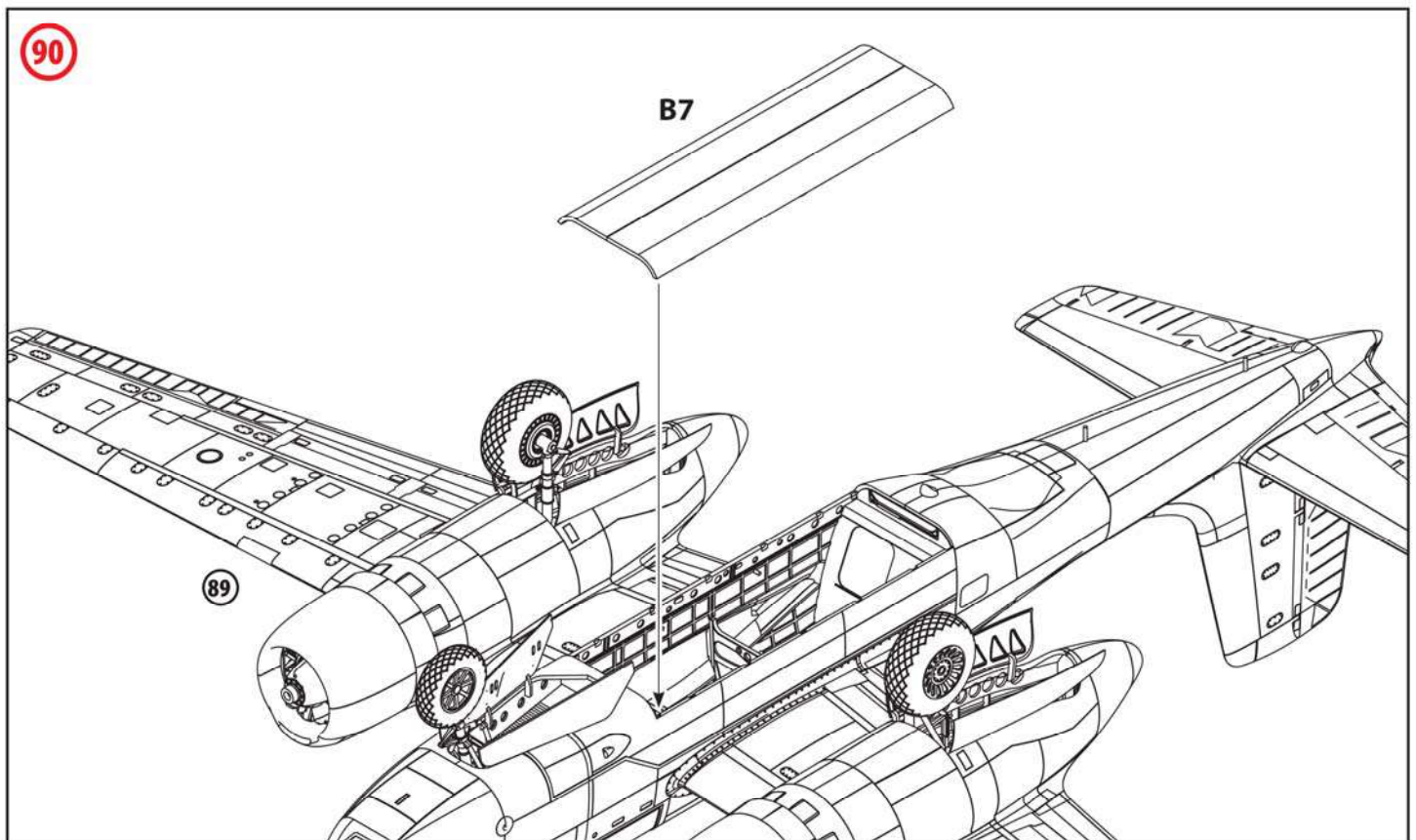
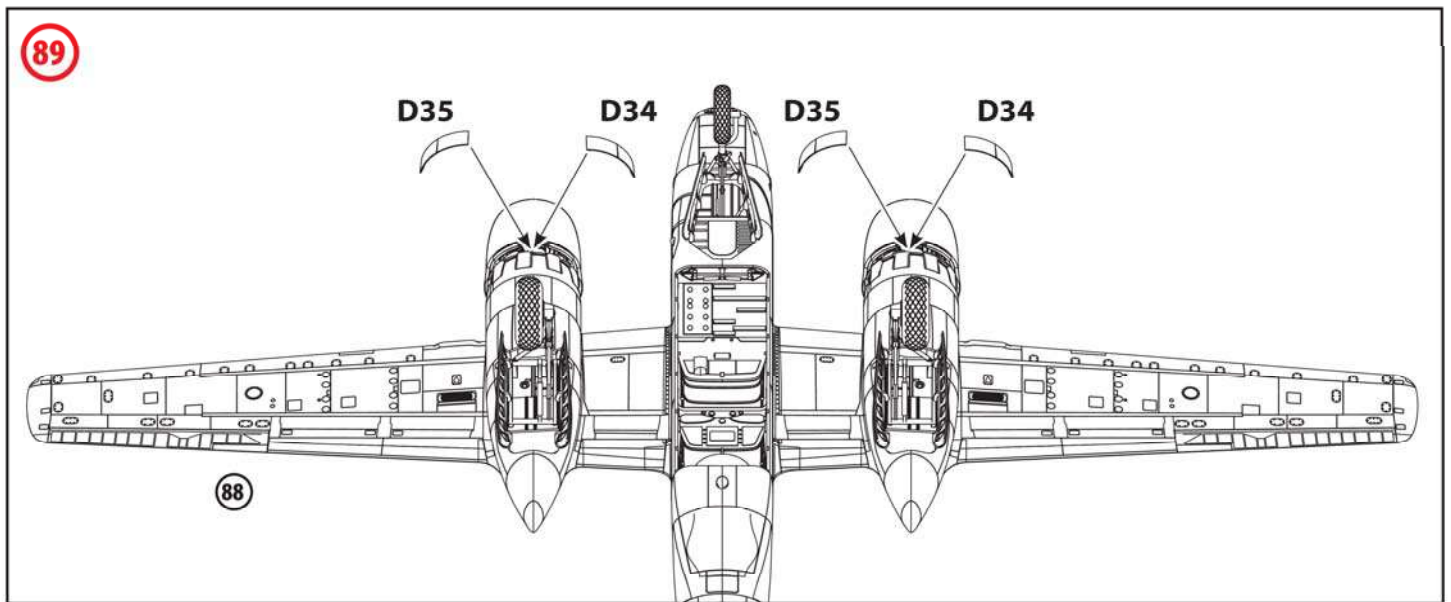
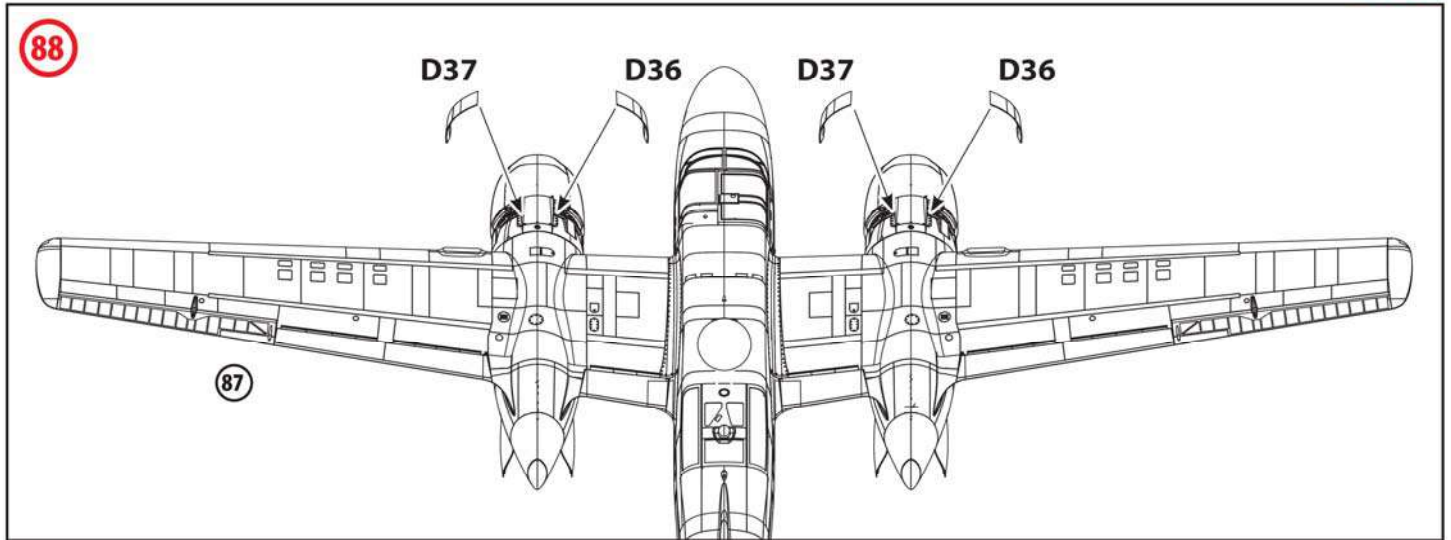

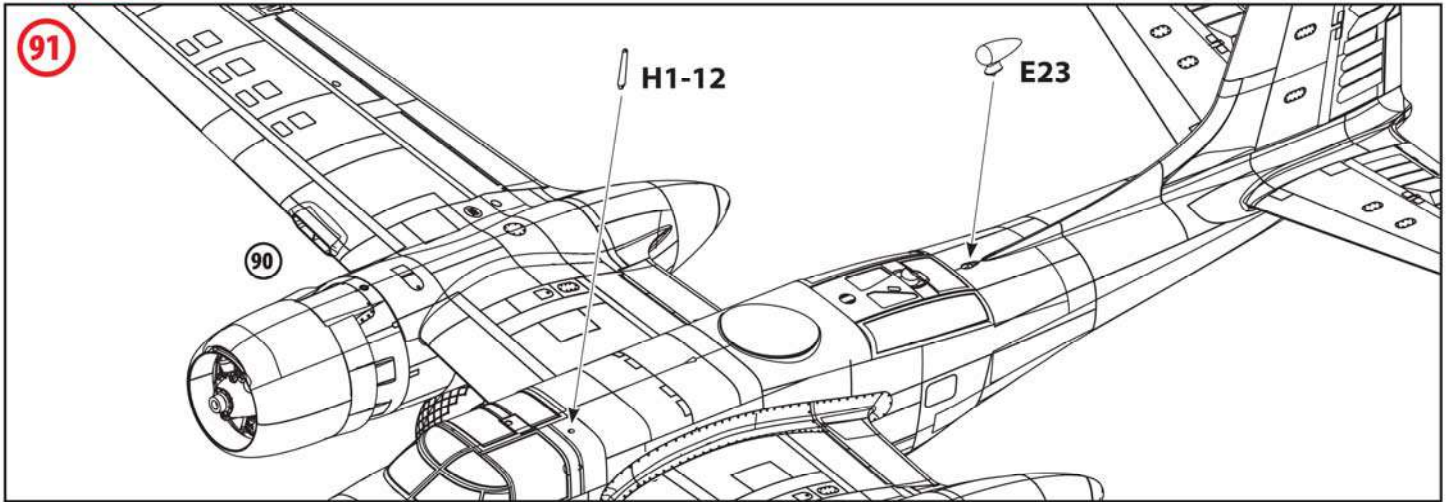

KDA-1 (Q-2A) Firebee

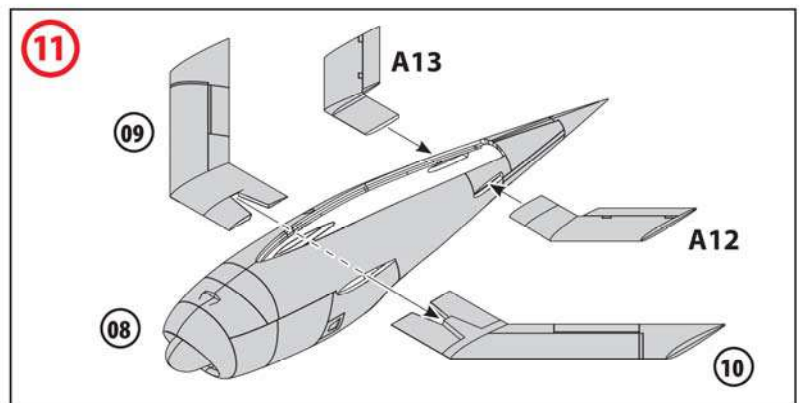
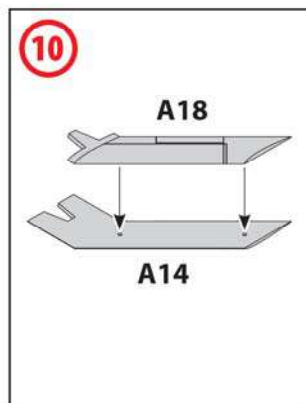
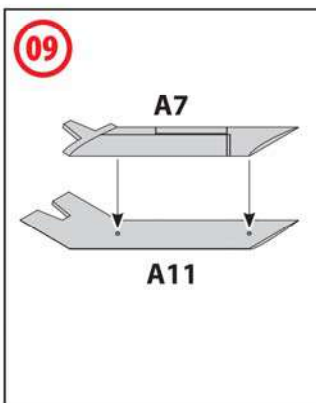
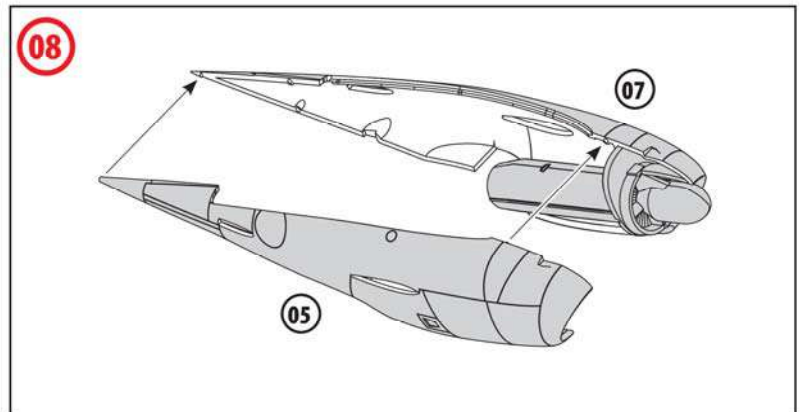
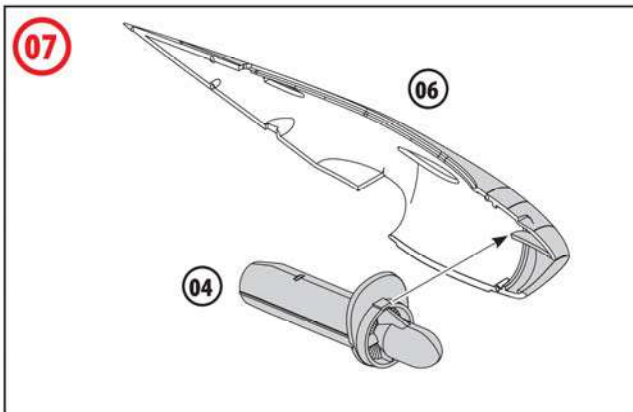
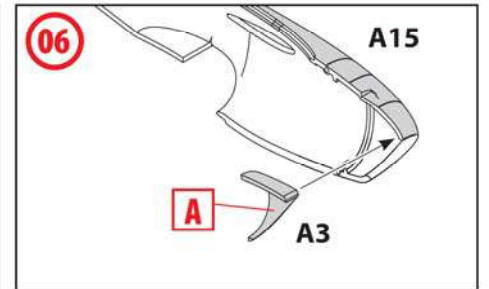
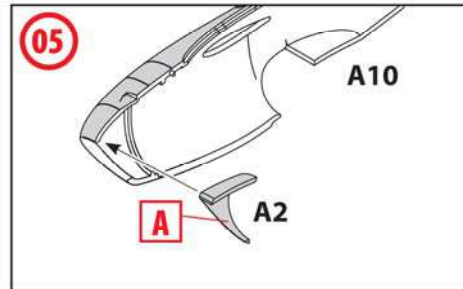
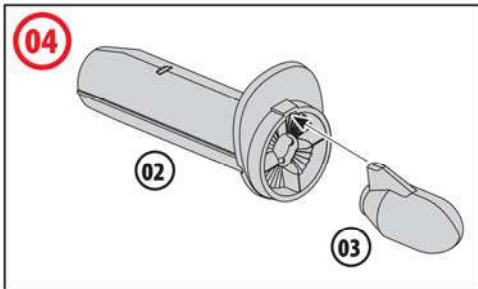
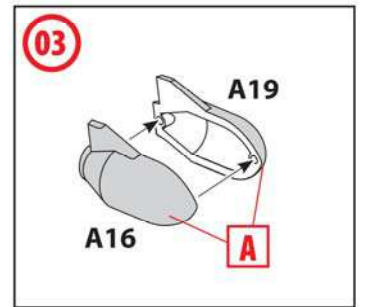
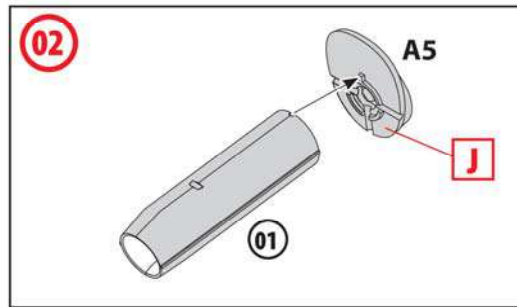
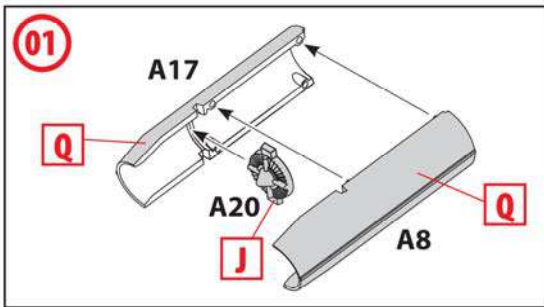

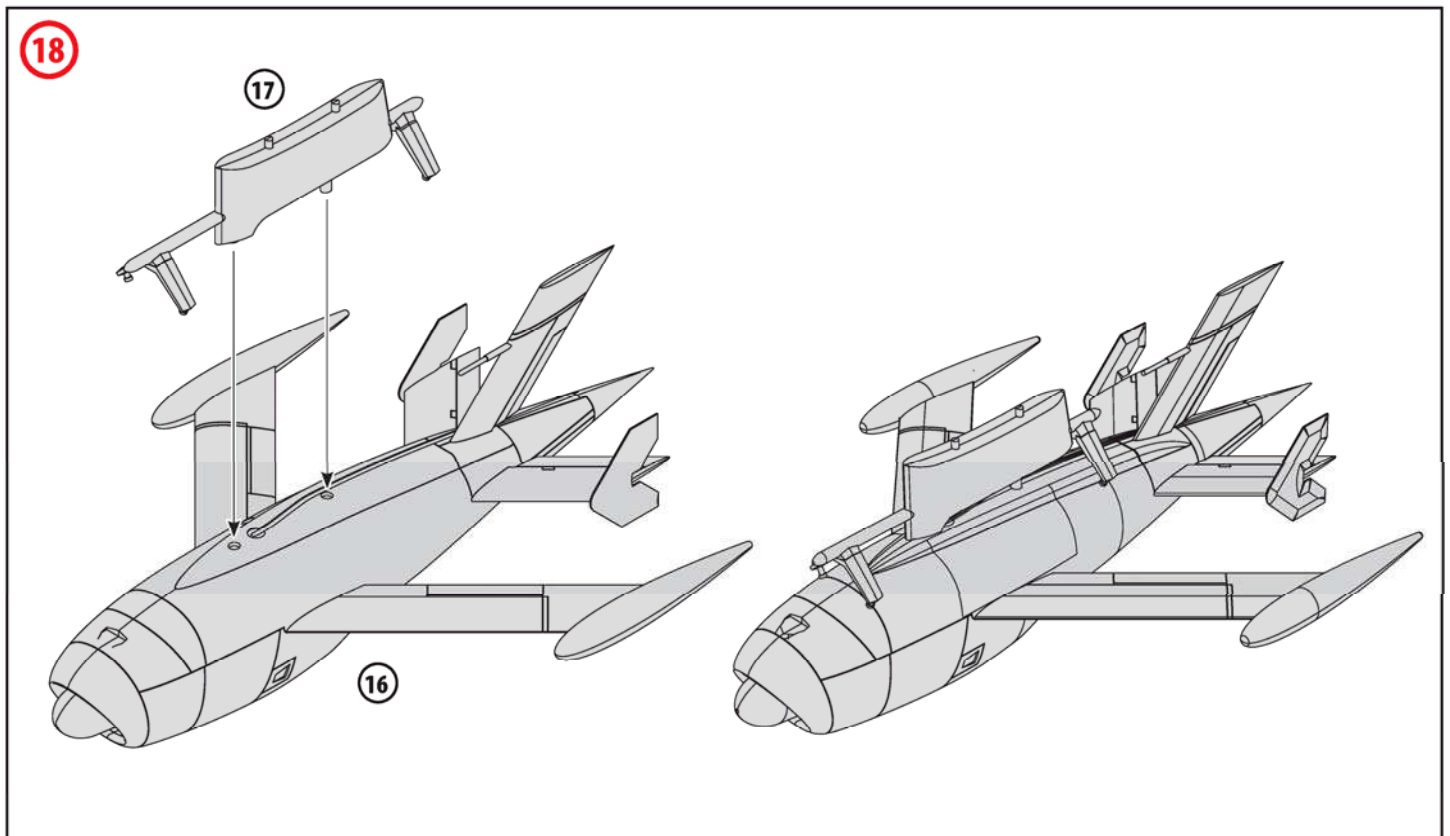
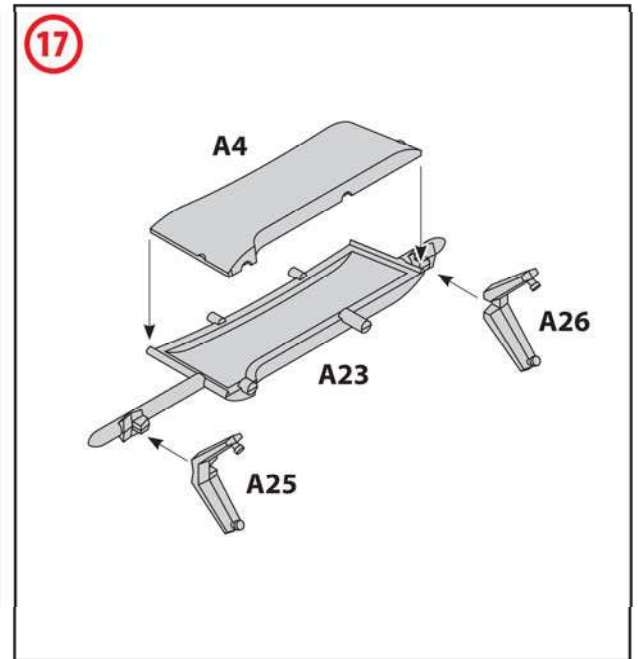
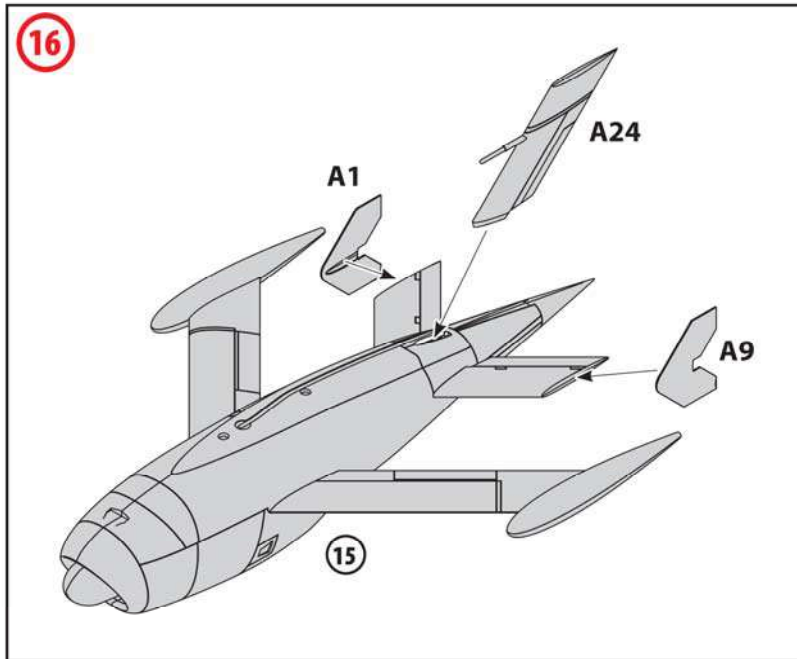
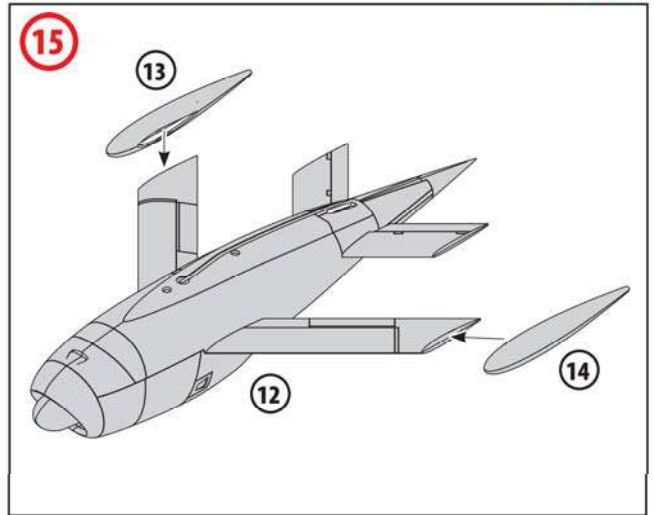
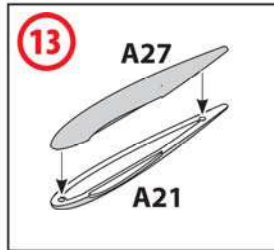
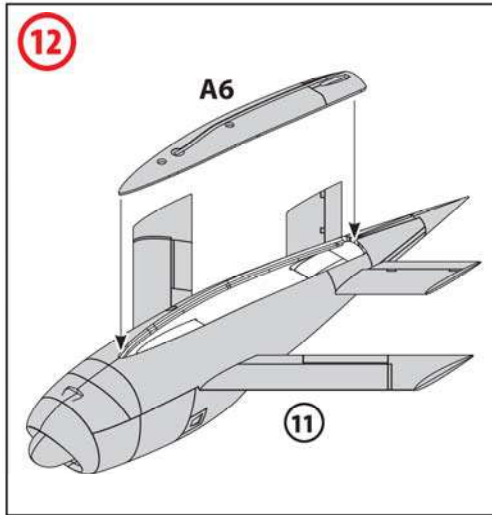

BQM-34A (Q-2C) Firebee

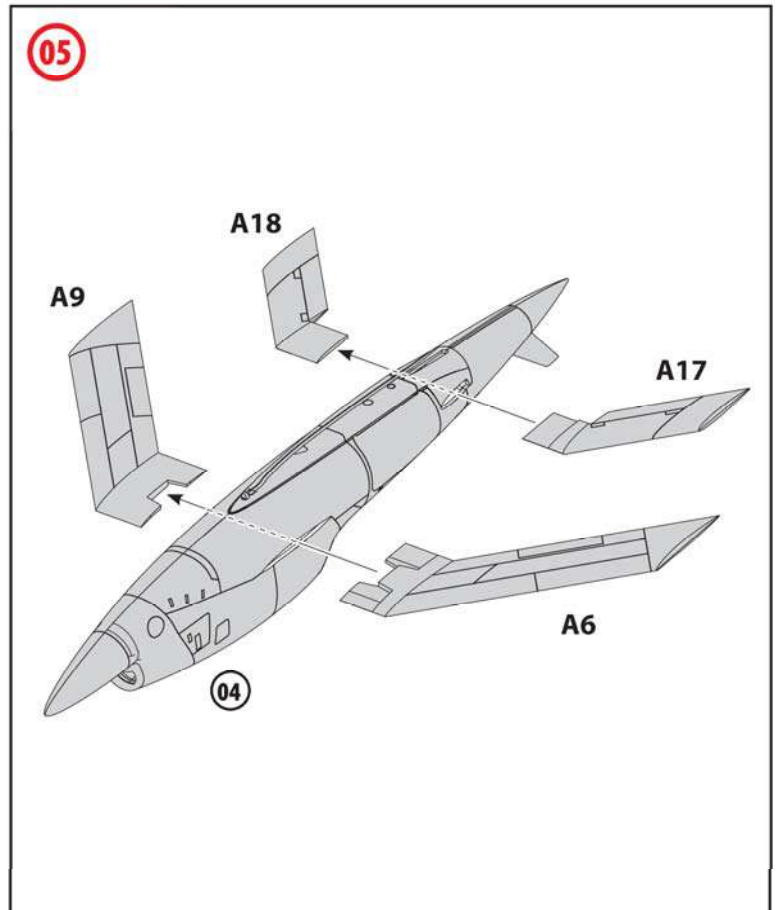
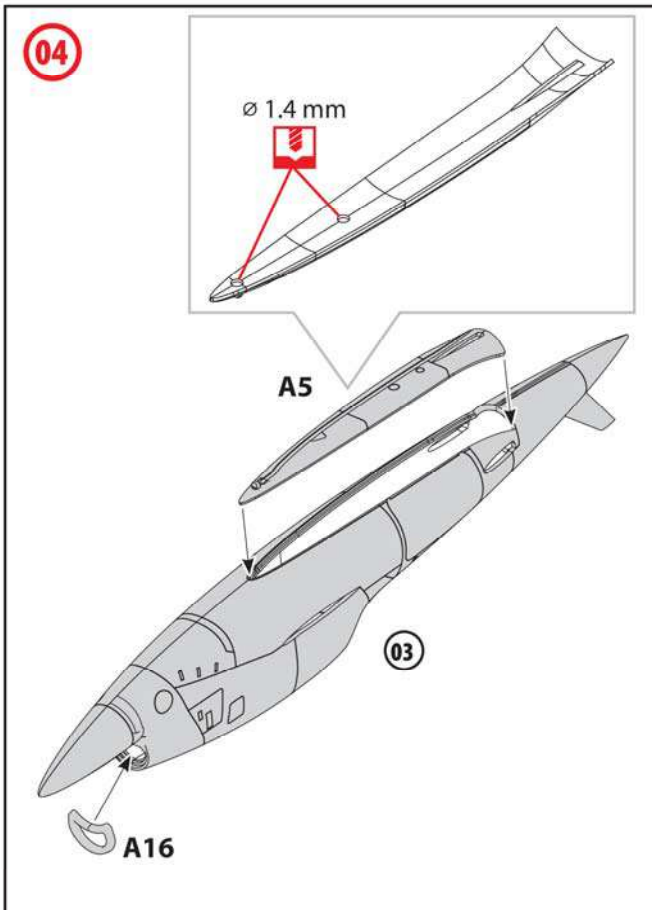
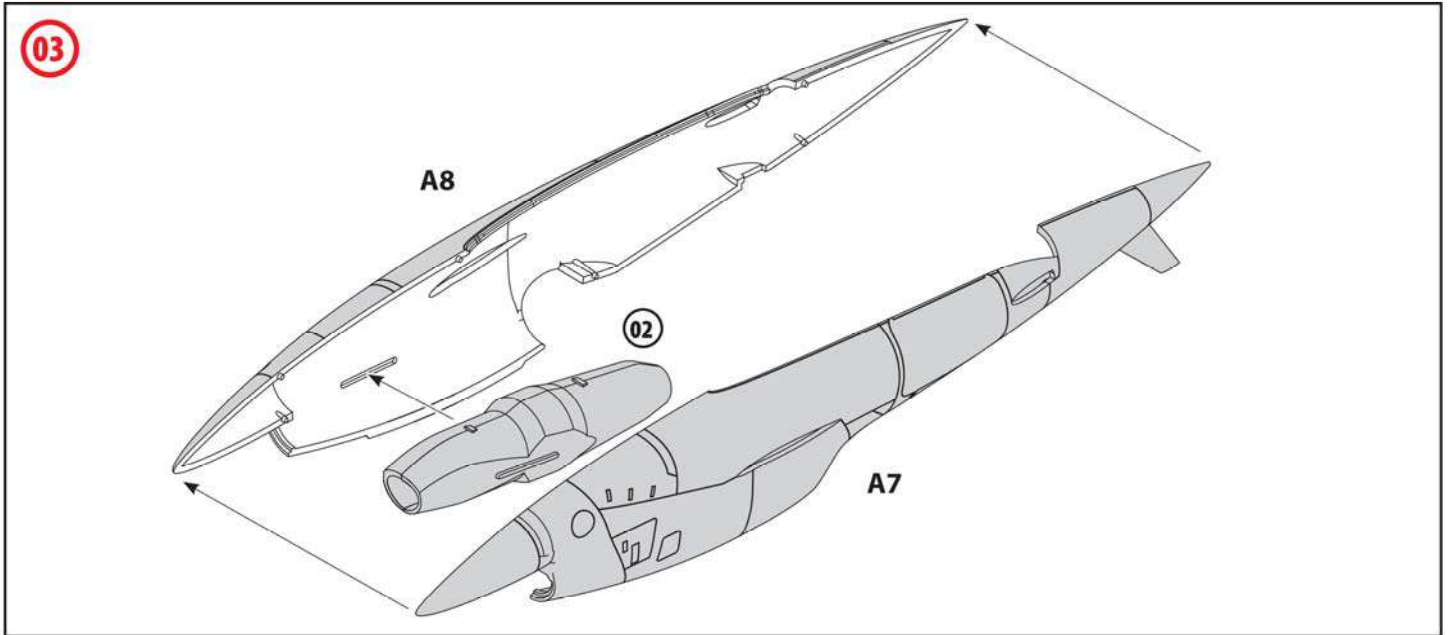
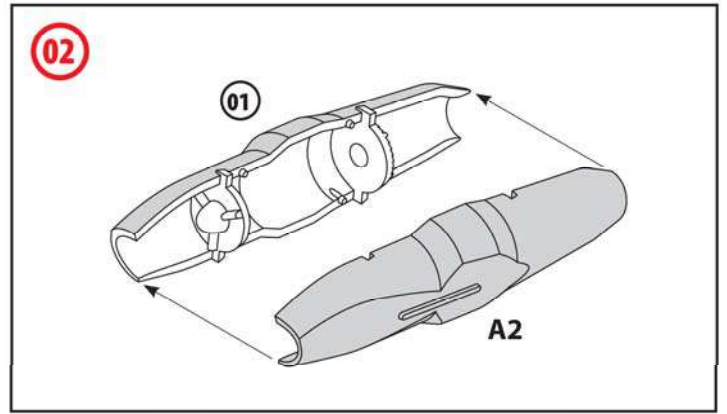
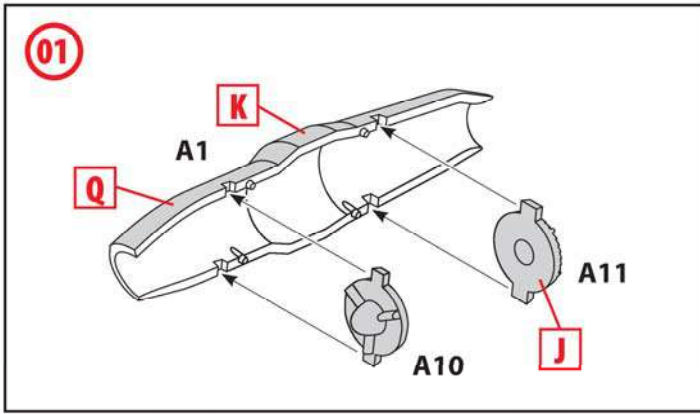

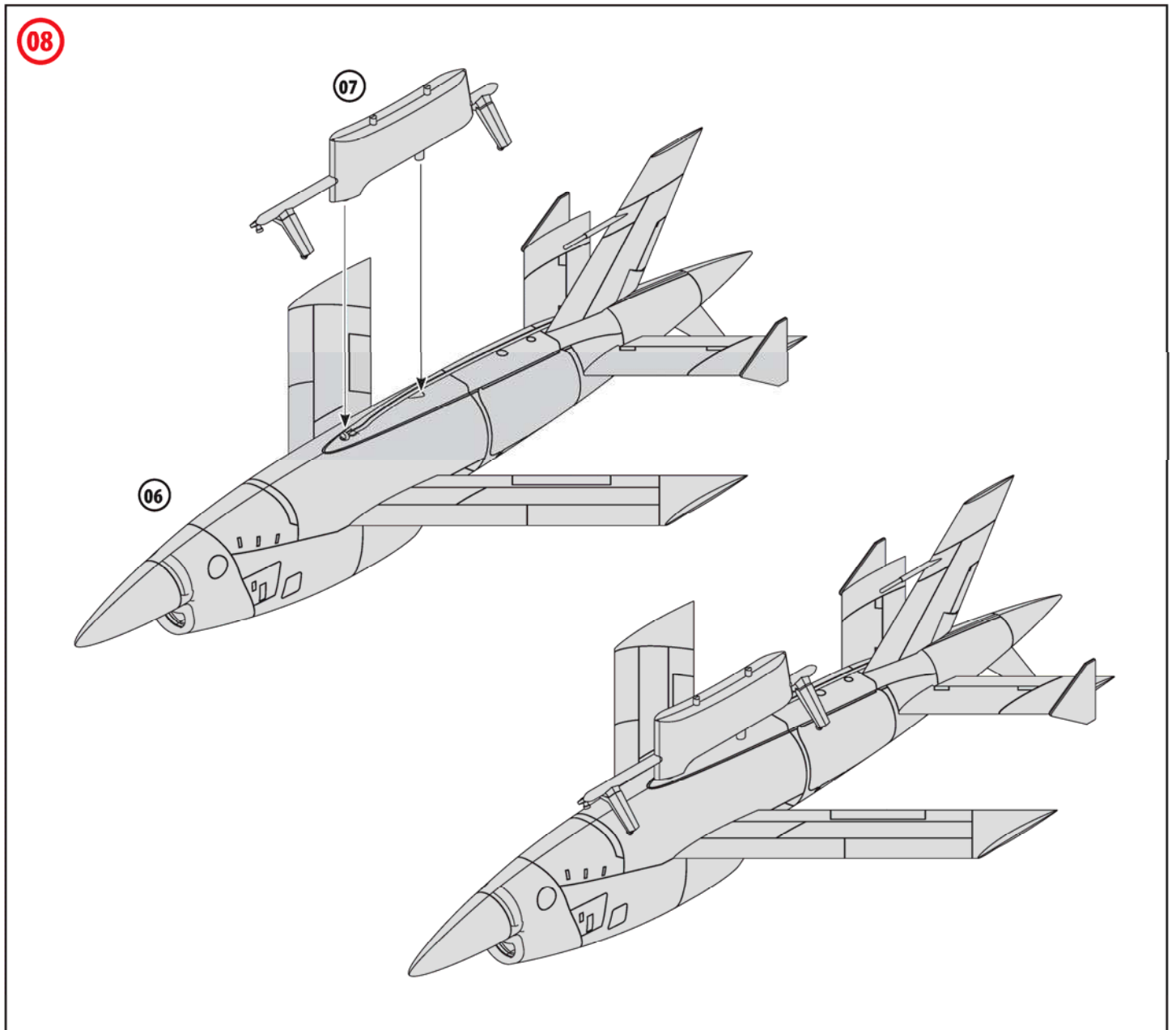
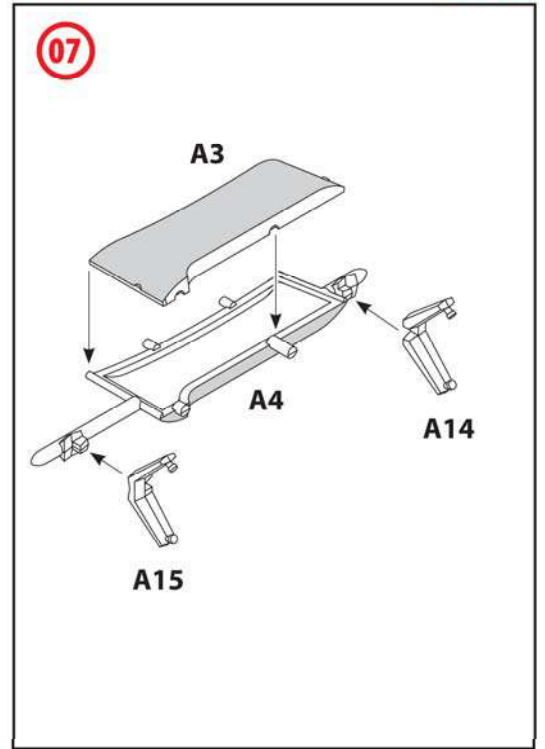
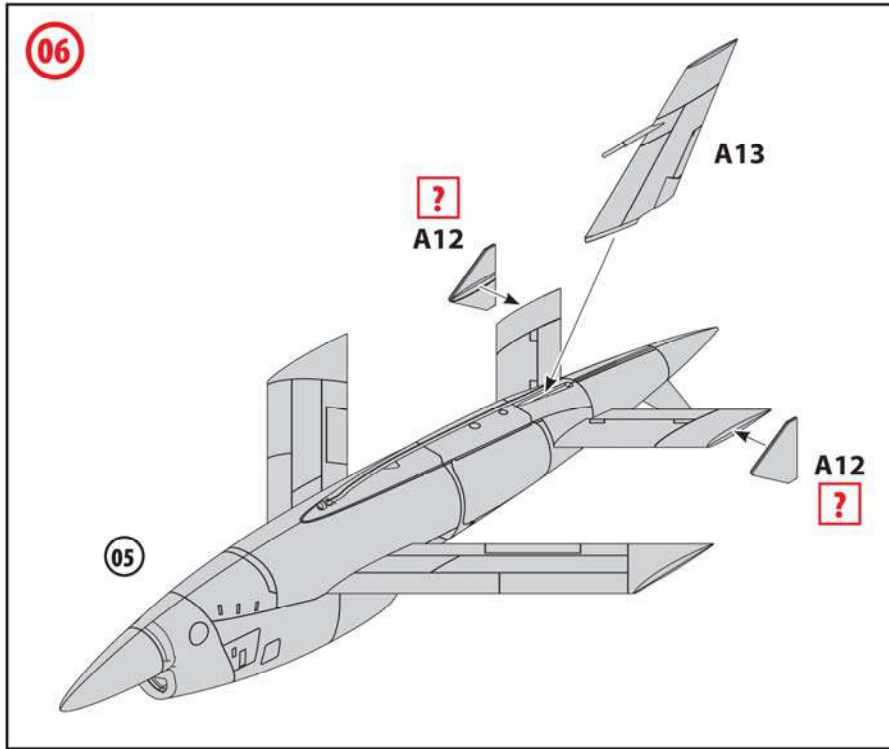

92

BQM-34A (Q-2C) Firebee

08

KDA-1 (Q-2A) Firebee

18

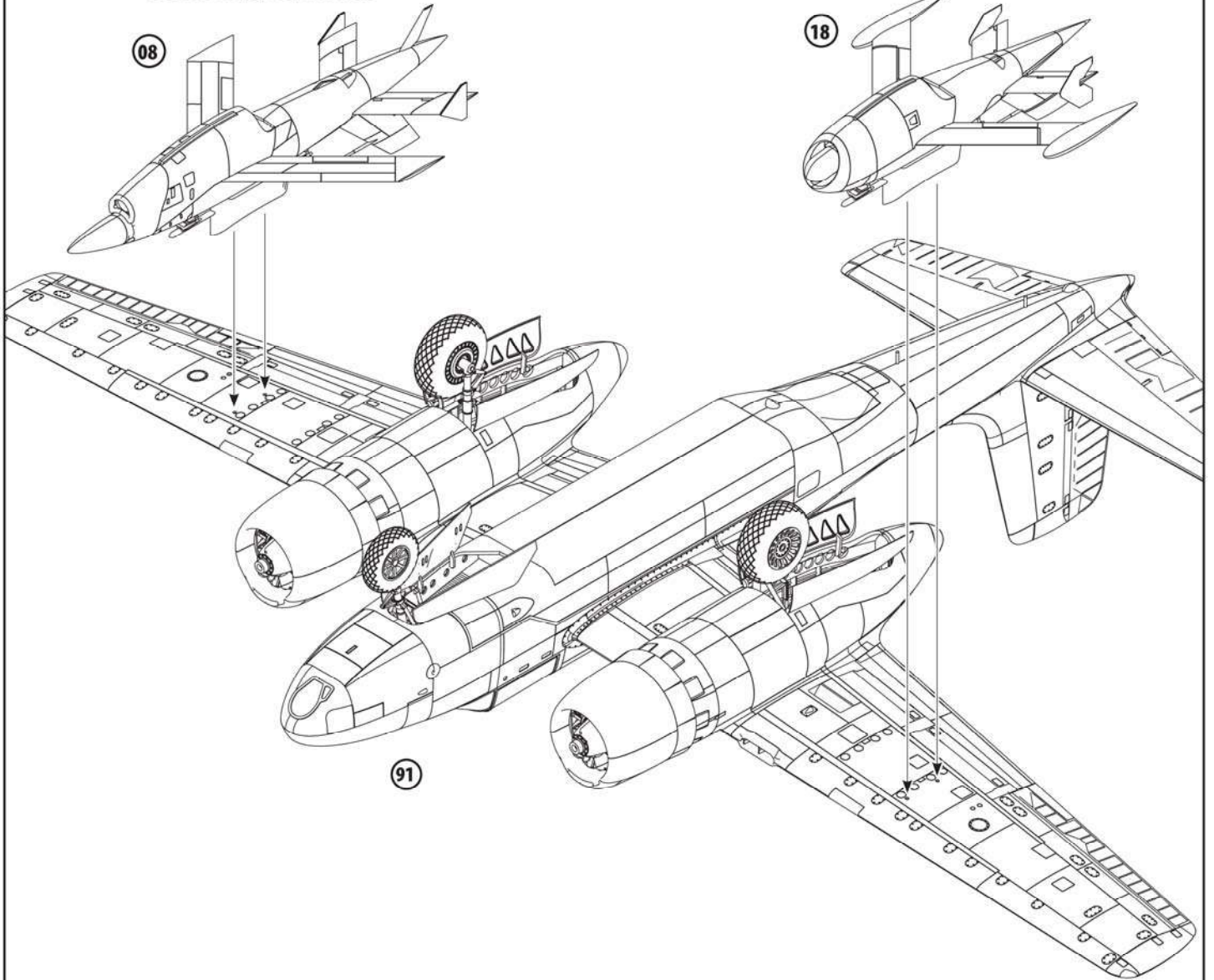

93

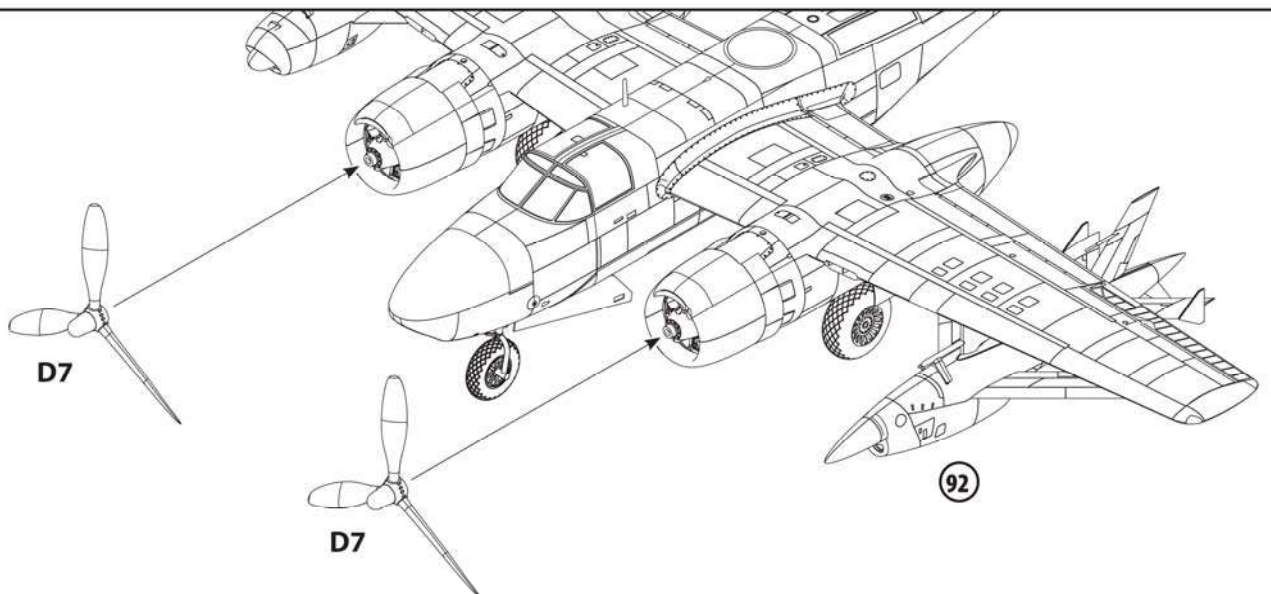

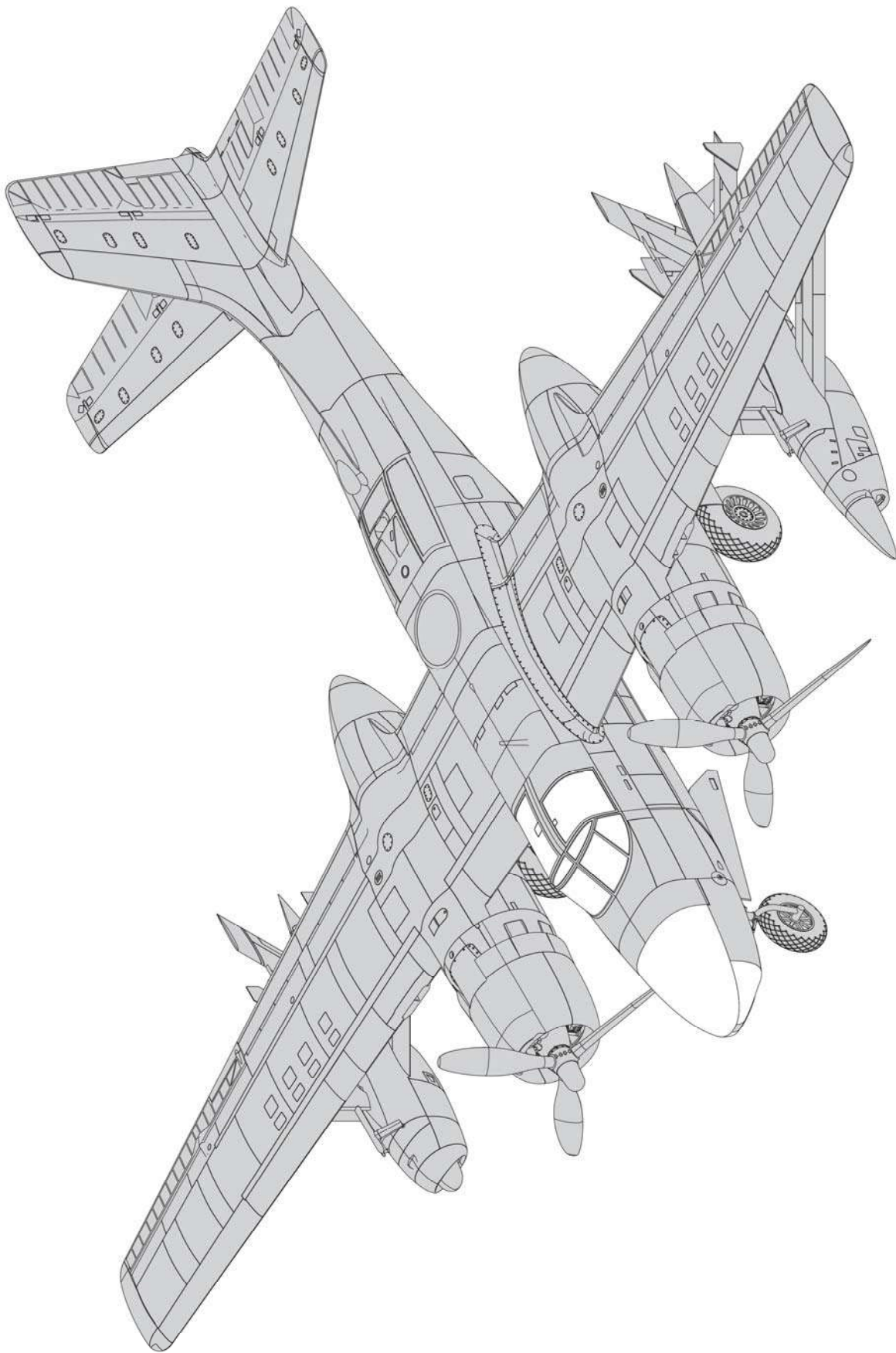

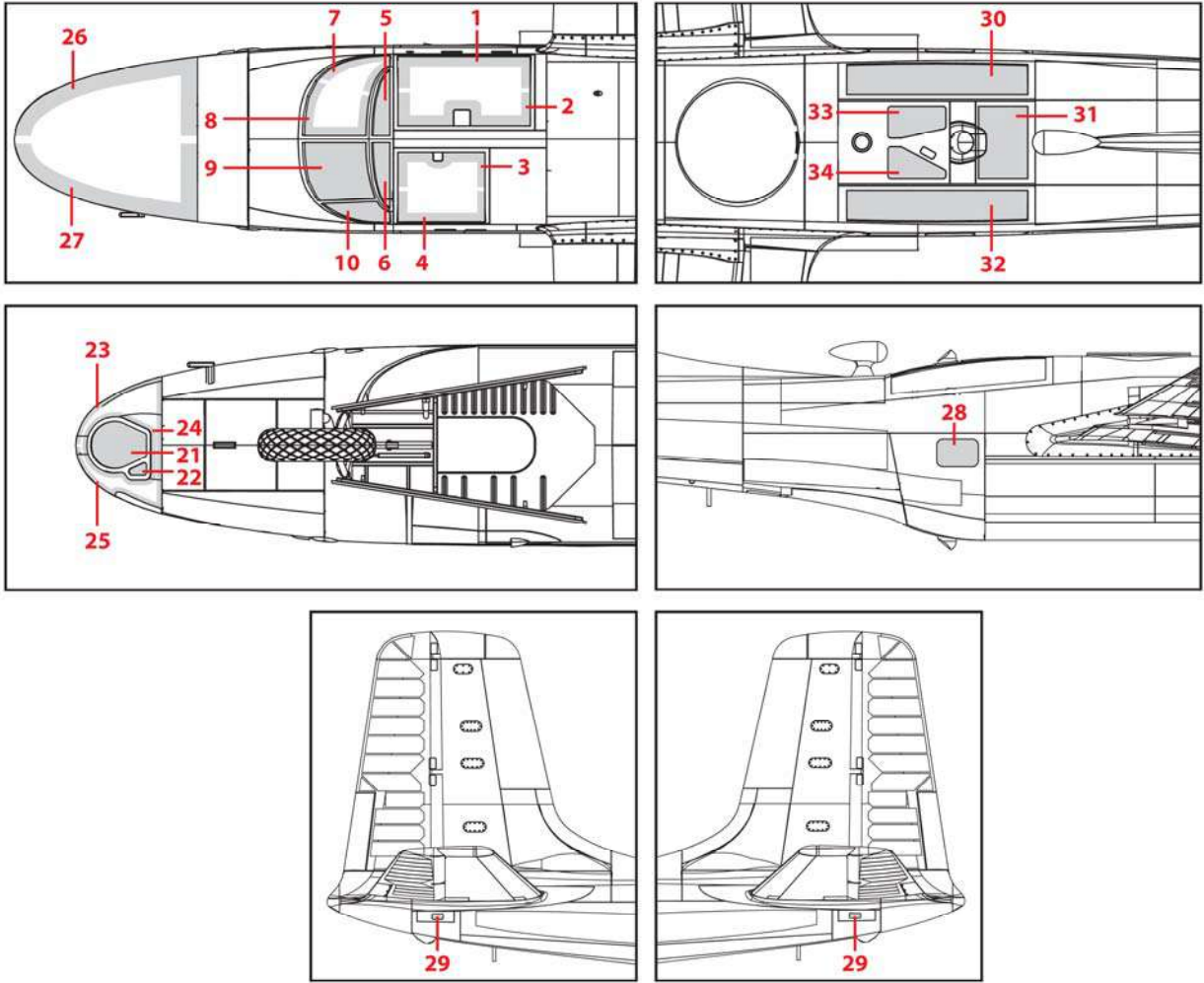

**ШАБЛОНЫ МАСОК
MASK TEMPLATES**

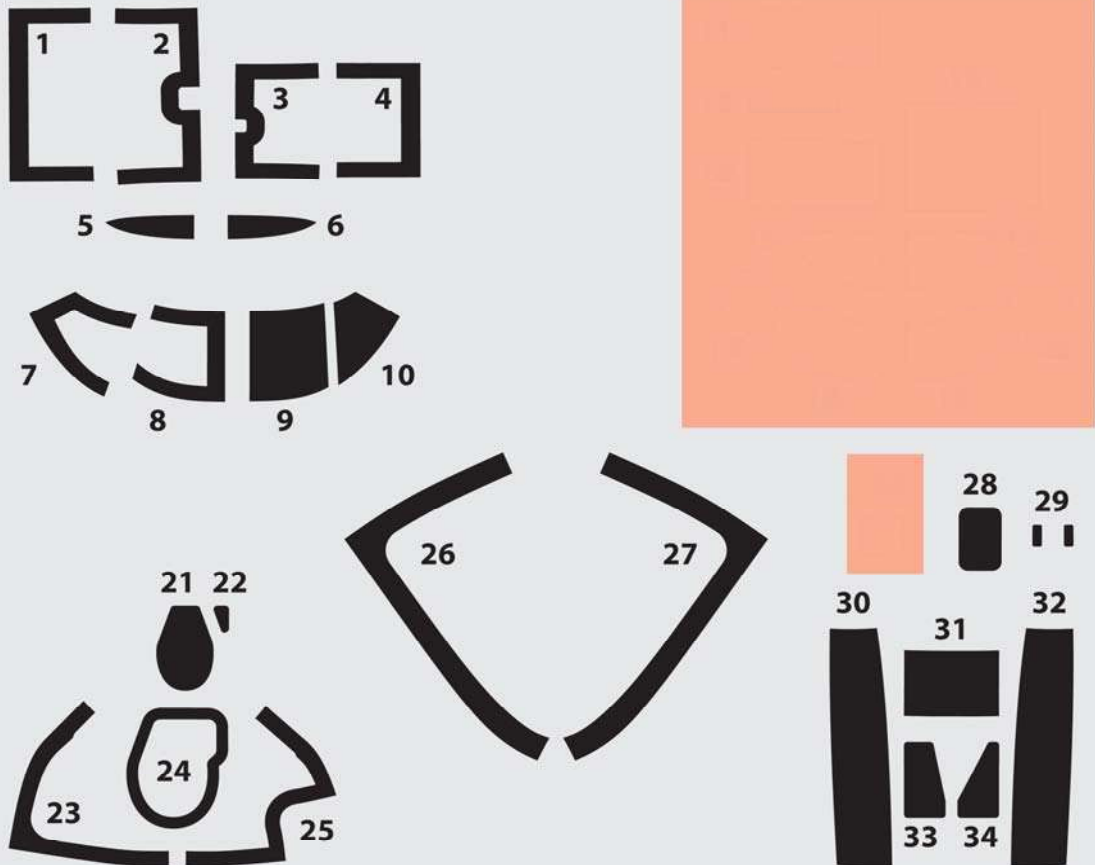

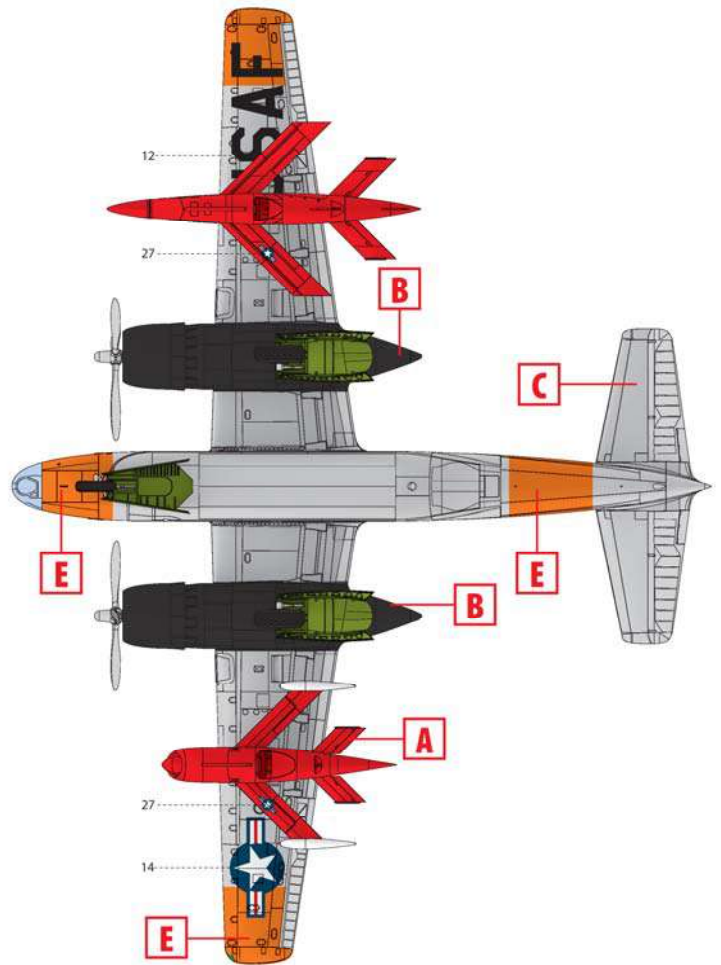
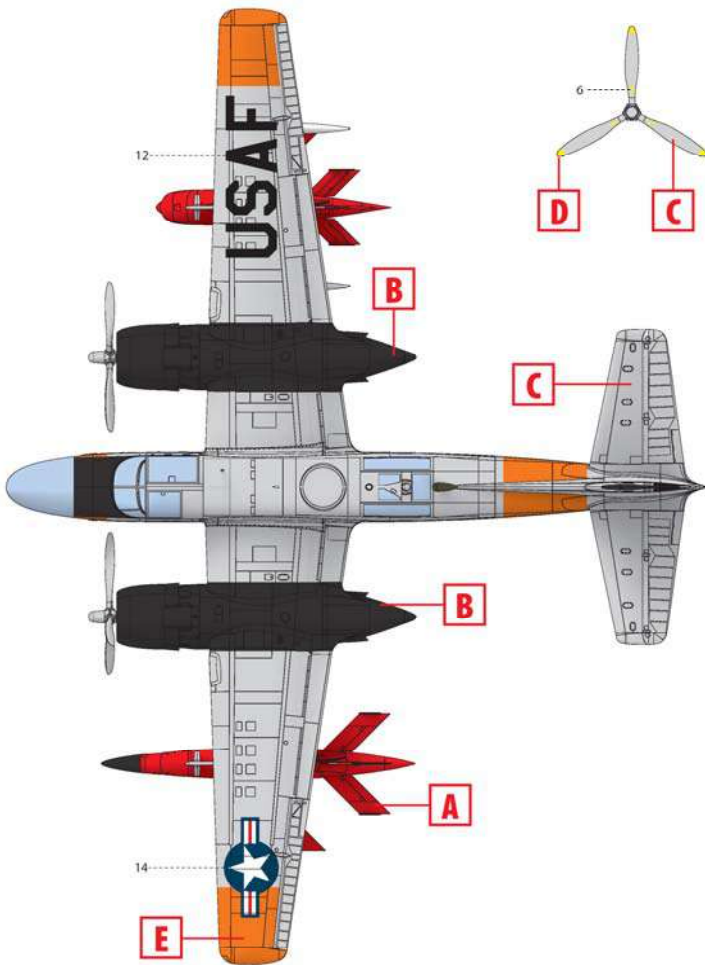
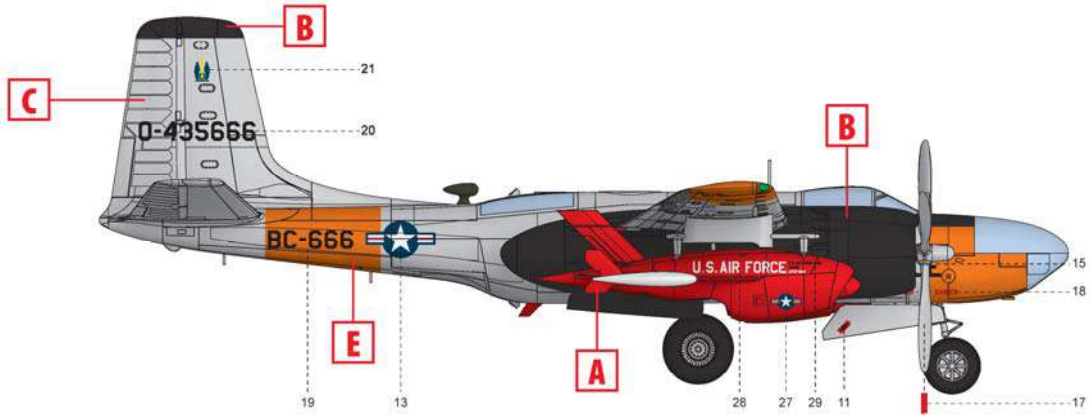
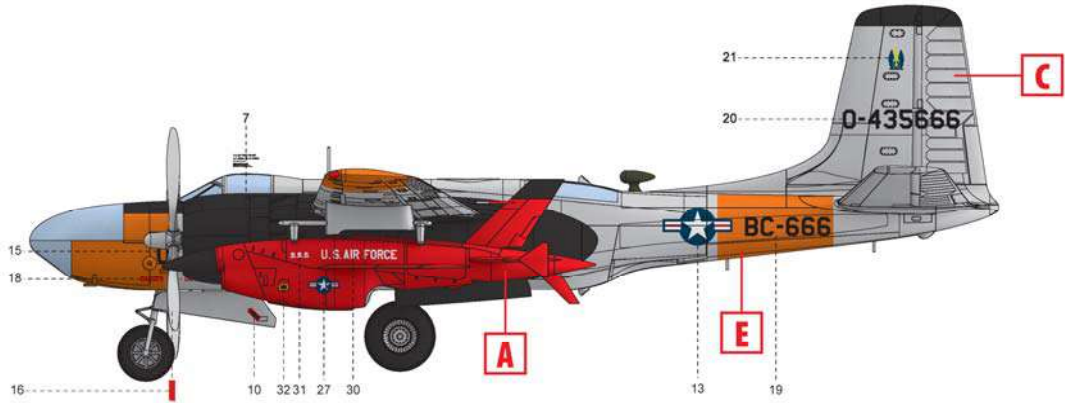

1. Носитель беспилотников DB-26C 44-35666, BBC США, авиабаза Холломан, конец 1950-х
 Drone Carrier DB-26C 44-35666, USAF, Holloman AFB, late 1950s

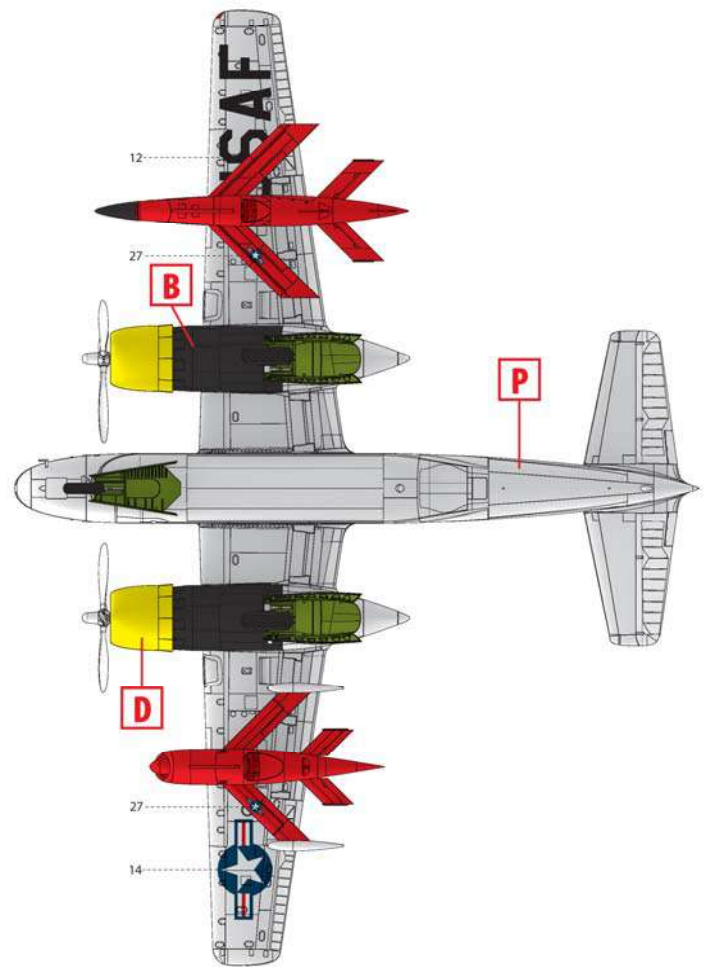
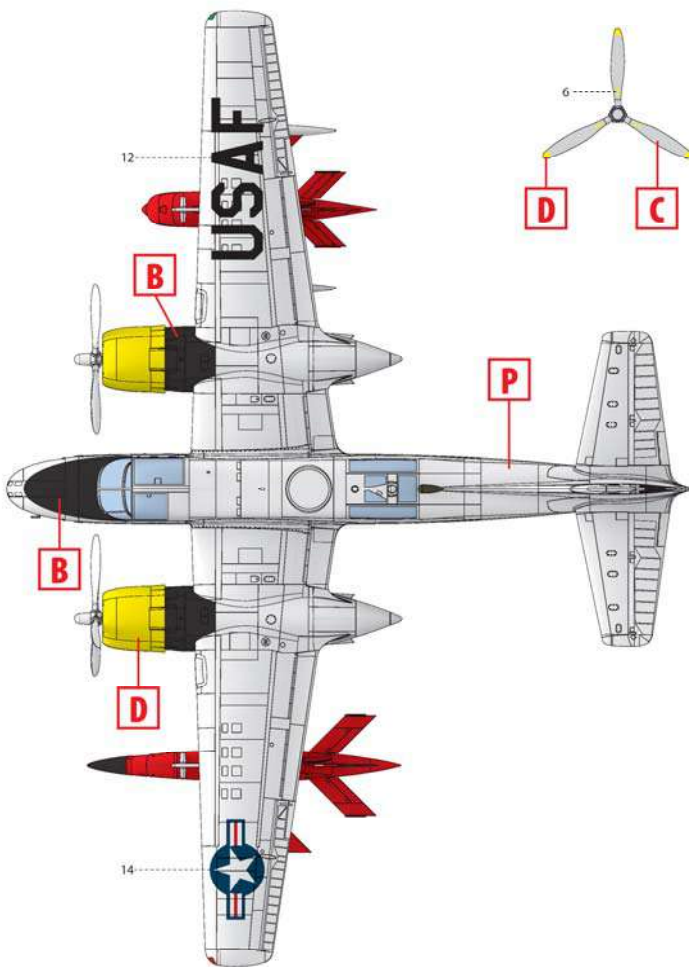
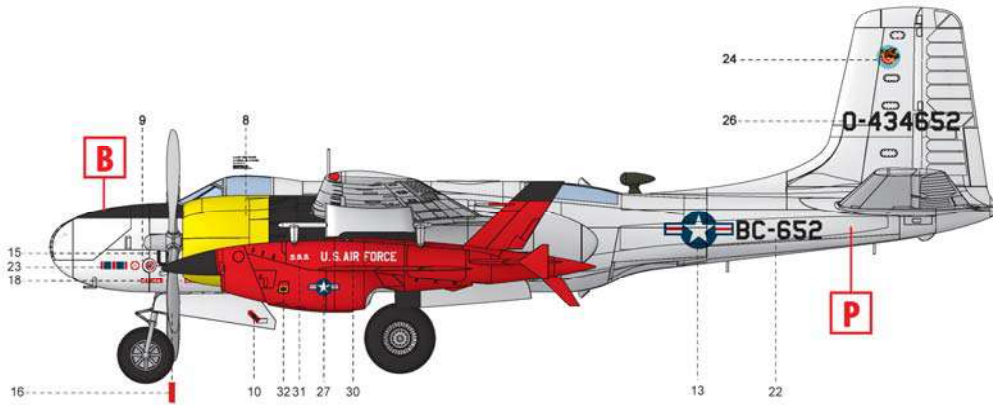

2. Носитель беспилотников DB-26B 44-34652, ВВС США, авиабаза Тиндалл, конец 1950-х
Drone Carrier DB-26B 44-34652, USAF, Tyndall AFB, late 1950s