



Leyland Retriever General Service (early production)

1/35 SCALE MODEL KIT No 35602

Leyland Retriever General Service (раннего производства) Британский грузовой автомобиль II MB

Leyland Retriever - британский грузовик 6x4 времен Второй мировой войны. Многие считали его обновленной версией Terrier. Было выпущено три разные версии, различающиеся только деталями. В период с 1938 по 1942 год было построено в общей сложности 6542 машины, включая машины общего назначения и другие модификации. Они использовались в Северной Африке и Северо-Западной Европе в период с 1942 по 1945 год, оставаясь в строю после Второй мировой войны.

Leyland Retriever General Service (early production) WWII British Truck

The Leyland Retriever was 6x4 WWII British truck. It was seen by many as an updated version of the Terrier. Three different versions were produced differing only in detail. A total of 6542 were believed to have been built between 1938 and 1942, including general service and another modifications. They were used in North Africa and NW Europe between 1942 and 1945, remaining in service after WWII.

Тактико-технические характеристики броневедомоля Leyland Retriever General Service (раннего производства)

Грузоподъемность, т	3
Длина, мм	6850
Ширина, мм	2270
Высота, мм	3450
База, мм	3962
Двигатель	«Лейланд», 4-цил., 5,9 л, 73 л.с.

Tactical and Technical Specifications of Leyland Retriever General Service (early production)

Full load, t	3
Length, mm	6850
Width, mm	2270
Height, mm	3450
Wheel base, mm	3962
Engine	Leyland 4-cylinder, 5.9 l, 73 hp

ИСПОЛЬЗУЕМЫЕ КРАСКИ / USED COLORS:

COLOR	Revell	Tamiya
A Белый, матовый Flat White	105	XF2
B Черный, глянцевый Gloss Black	107	X1
C Черный, полуматовый Semigloss Black	302	X18
D Оливково-зеленый, мат. Olive Green	165	XF58
E Хаки, матовый Khaki	186	XF49

COLOR	Revell	Tamiya
F Дерево Wood	189	XF78
G Сталь Steel	191	X32
H Серебристый Chrome Silver	190	X11
J Красный, прозрачный Clear Red	731	X27
K Ржавчина Rust	183	XF84

01 СТАДИЯ СБОРКИ
ASSEMBLY STEP

A ИСПОЛЬЗУЕМАЯ КРАСКА
USED COLOR

***** СДЕЛАТЬ САМОМУ
SCRATCH BUILD

□ ПРИ СБОРКЕ НЕ ИСПОЛЬЗУЕТСЯ
PARTS NOT FOR USE

03 СБОРОЧНАЯ ЕДИНИЦА
ASSEMBLY UNIT

x2 СДЕЛАТЬ ДВЕ ДЕТАЛИ
MAKE 2 PCS

⊠ НЕ КЛЕИТЬ
DO NOT CEMENT

? ПРОИЗВОЛЬНЫЙ ВЫБОР
OPTIONAL

В Н И М А Н И Е !

Перед сборкой внимательно прочитайте руководство по монтажу. Каждая деталь пронумерована. Соблюдать последовательность монтажа. Необходимые рабочие инструменты: нож и напильник для зачистки деталей; резиновая лента, клейкая лента и зажимы для сушки белья для прижимания склеиваемых деталей. Детали из пластика очистить в растворе мягкого моющего средства и высушить на воздухе для того, чтобы краска и переводные картинки лучше прилипали. Перед приклеиванием проверить, подходят ли детали; клей наносить экономно. Хром и краску удалить с поверхностей склеивания. Небольшие детали покрасить перед тем, как они будут удалены из рамок. Краску необходимо хорошо просушить, только после этого продолжать сборку. Каждую соответствующую переводную картинку отдельно вырезать и примерно на 20 секунд окунуть в теплую воду. На обозначенном месте картинку отделить от бумаги и прижать промокающей бумагой.

С А У Т Т И О Н !

Read the instructions thoroughly prior to assembly. Each component is numbered. Adhere to specified sequence of assembly. Tools required: knife and file for removal of components from frame; rubber bond, adhesive tape and clothes pegs for clamping components together after applying adhesive. Clean plastic components in a mild detergent solution and allow to air-dry so that paint and transfers adhere better. Prior to applying adhesive, check to see whether the components fit together; apply adhesive sparingly. Remove chrome and paint from the contact surfaces. Paint small components before removing them from the frame. Allow paint to dry well, and only then continue to assemble. Cut out each transfer individually and immerse in warm water for approx. 20 seconds. Slide transfer off paper and into designated position, then press on with blotting paper.

ООО ICM Холдинг
ул. Бориспольская 9, строение 64,
02099, Киев, Украина
Тел./факс: +38(044) 369 54 12
E-mail: export@icm.com.ua



ICM Holding
Borispolskaya, 9, build. 64,
02099, Kiev, Ukraine
Tel./Fax: +38(044) 369 54 12
E-mail: export@icm.com.ua

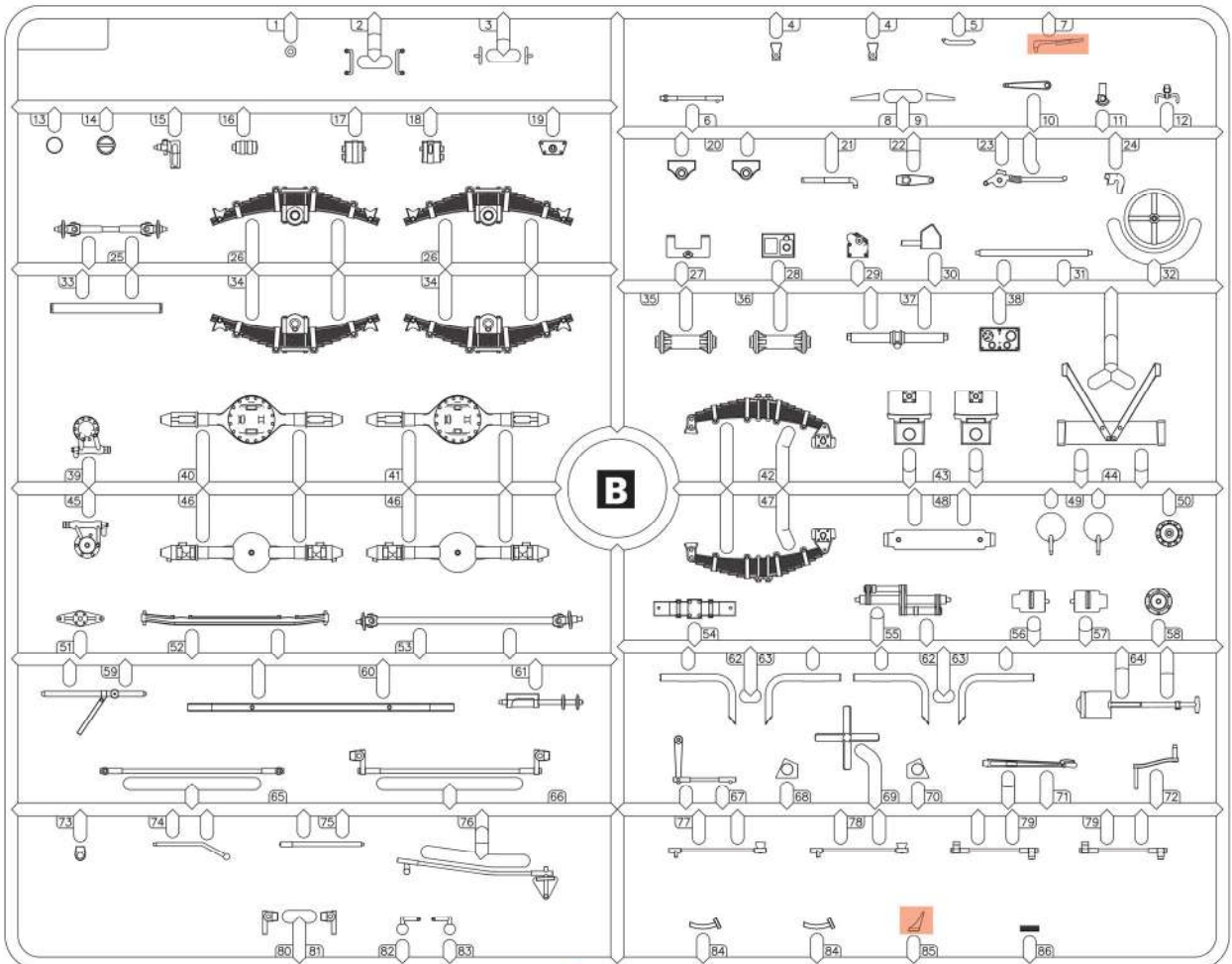
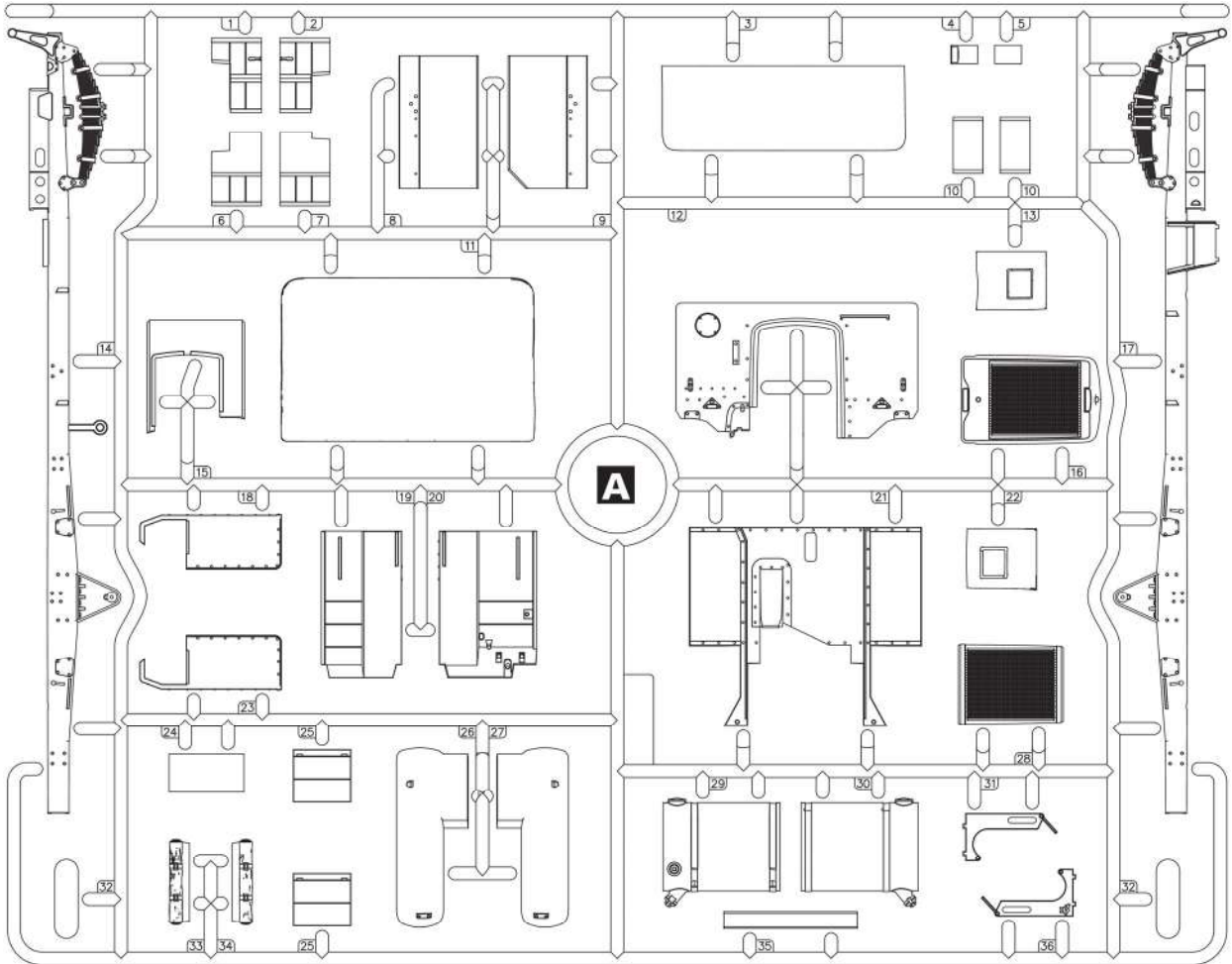

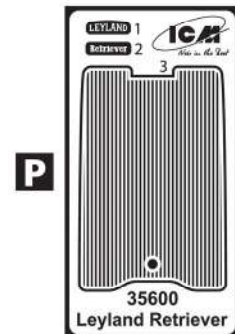
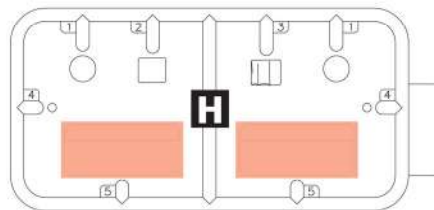
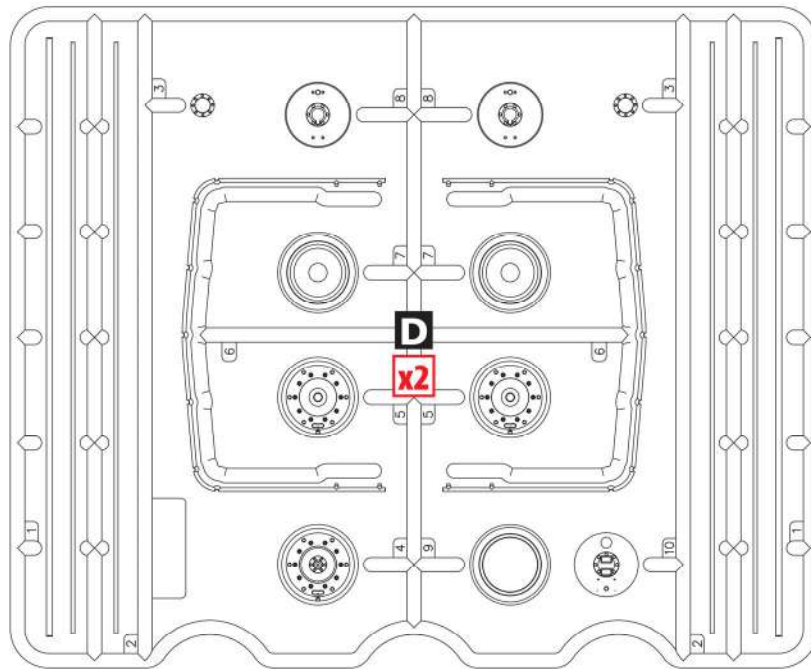
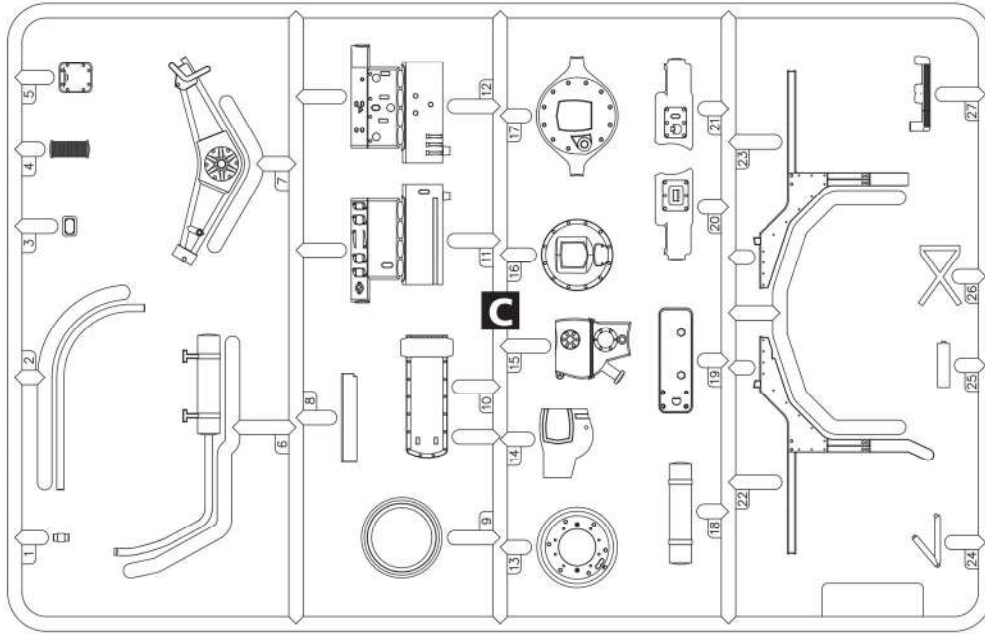

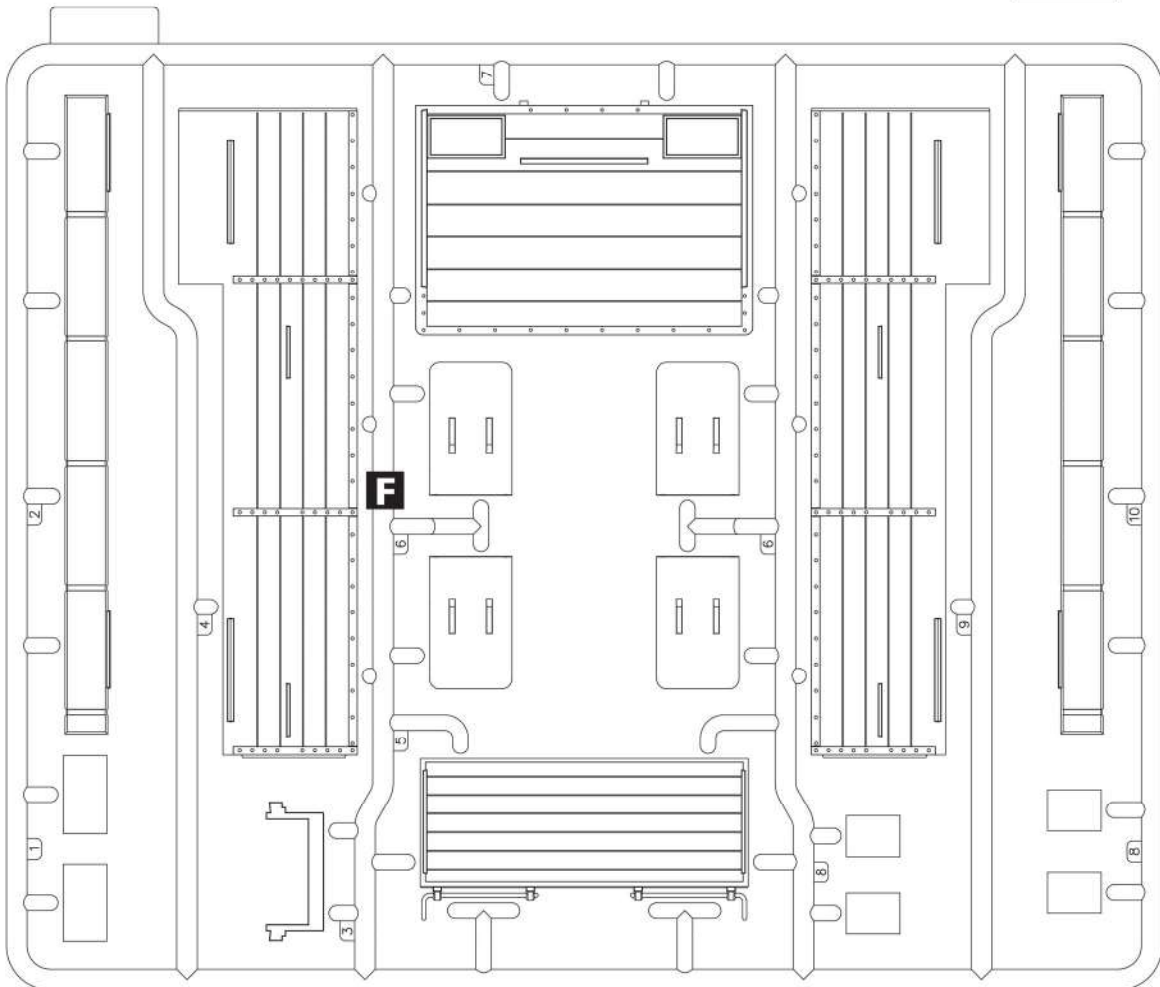
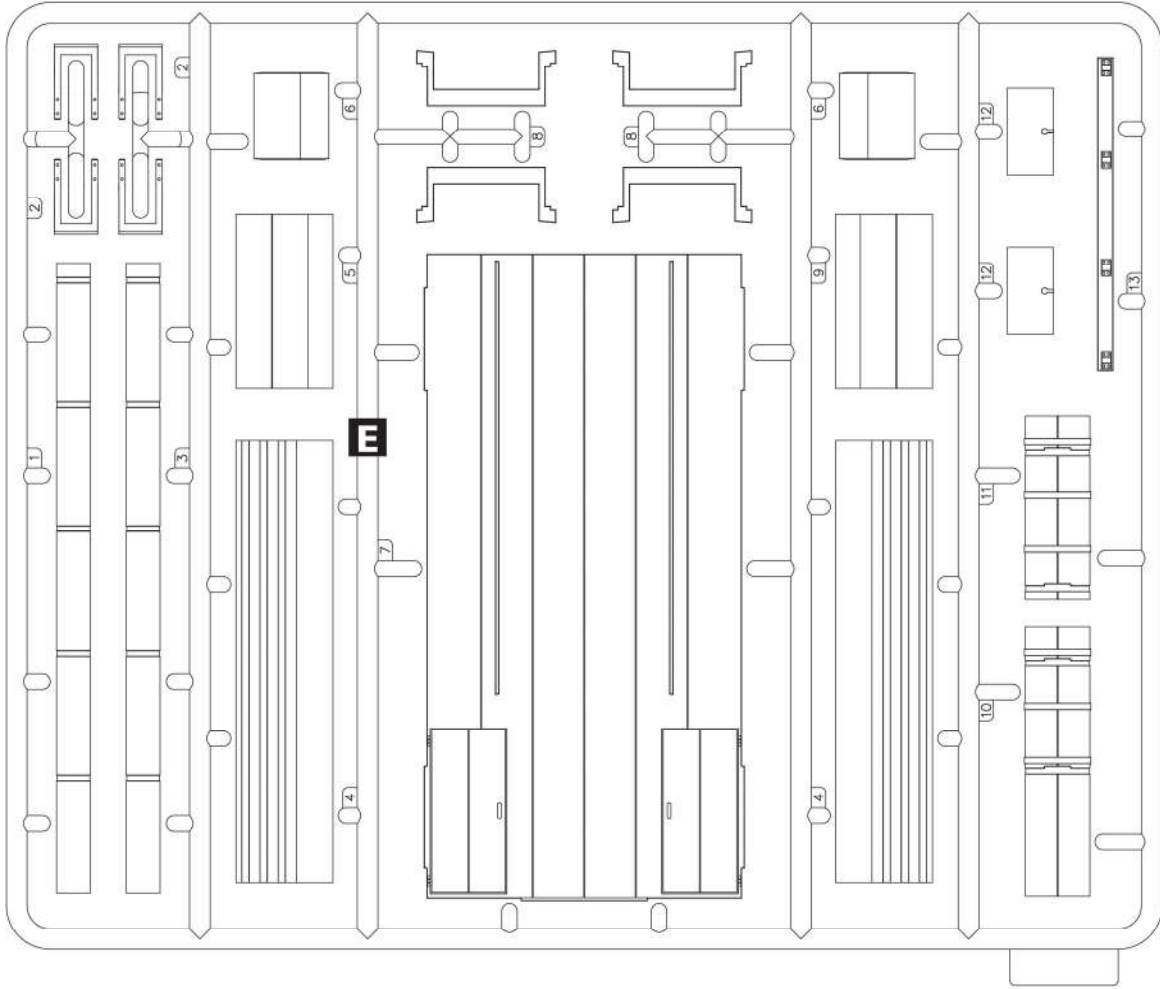

01

D ВСЕ ДЕТАЛИ, КРОМЕ ОБОЗНАЧЕННЫХ ОТДЕЛЬНО
ALL PARTS EXCEPT MARKED SEPARATELY

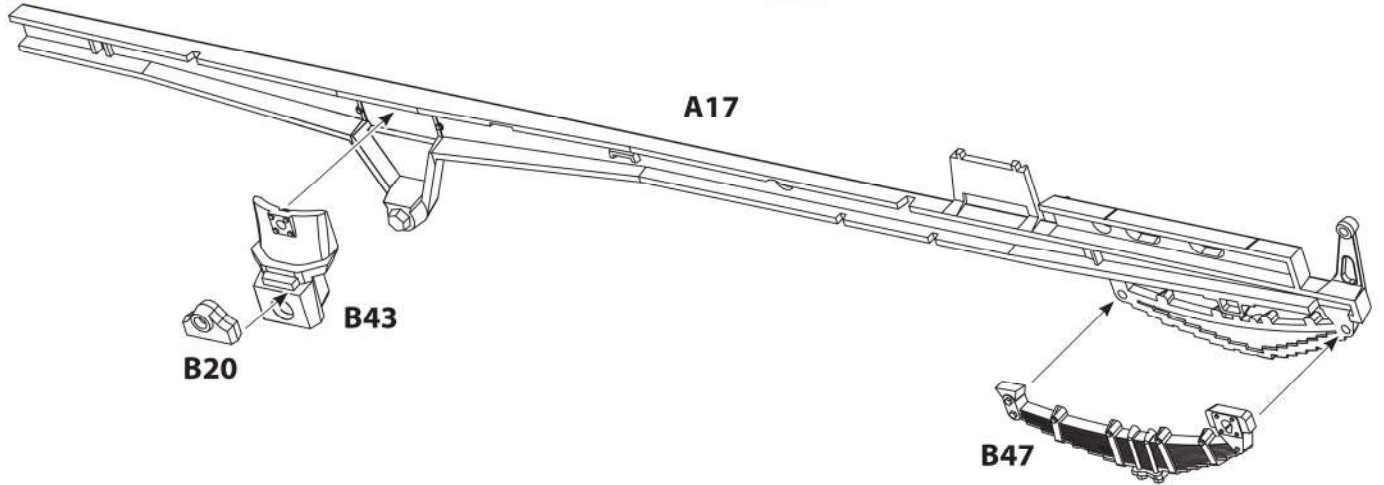

02

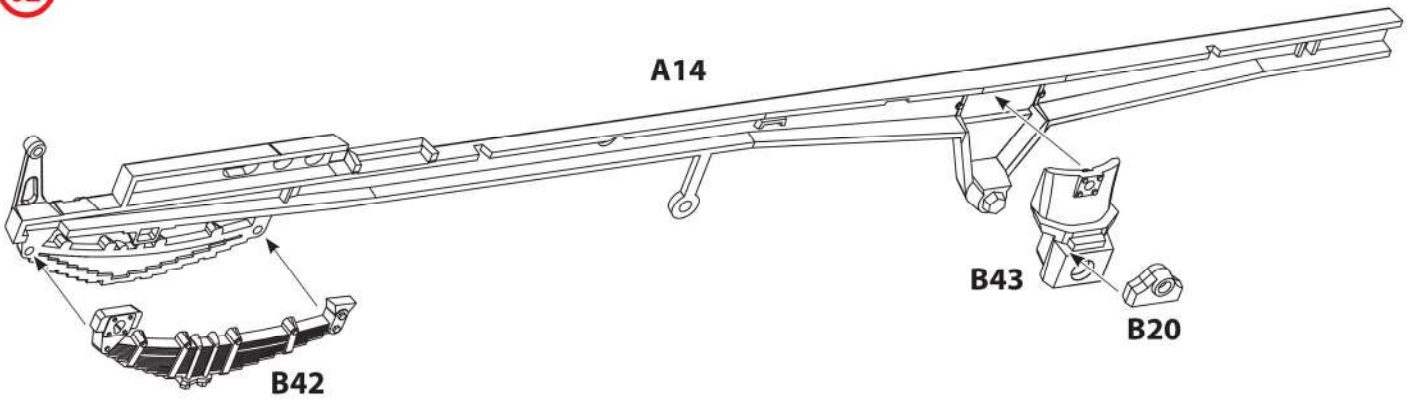

04

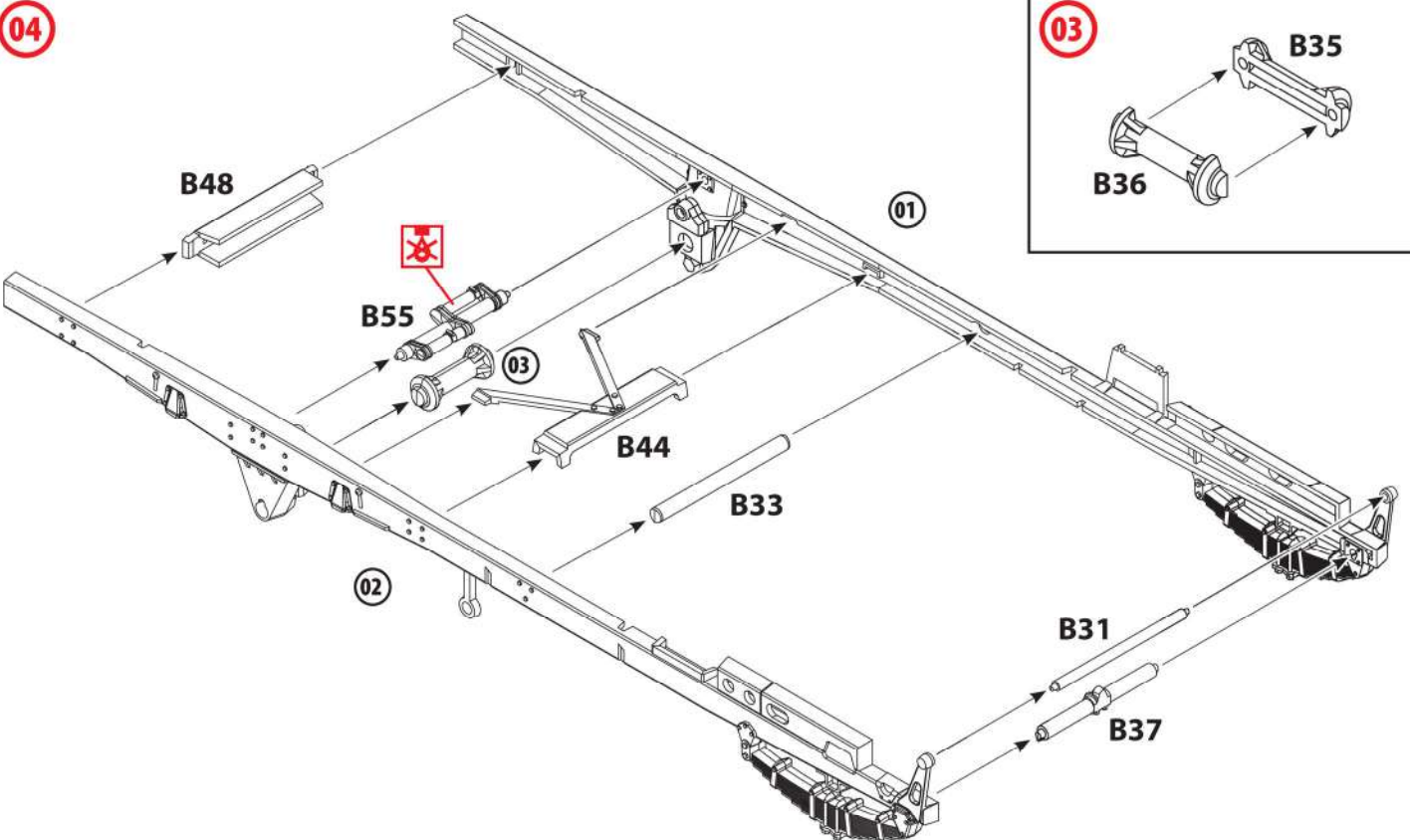

03

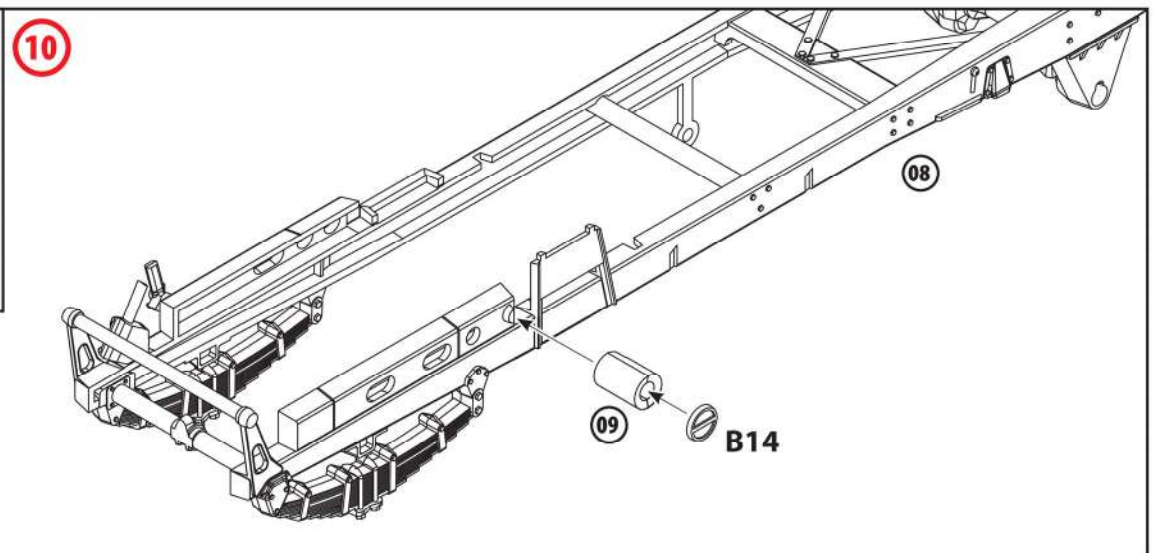
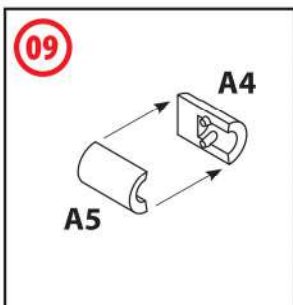
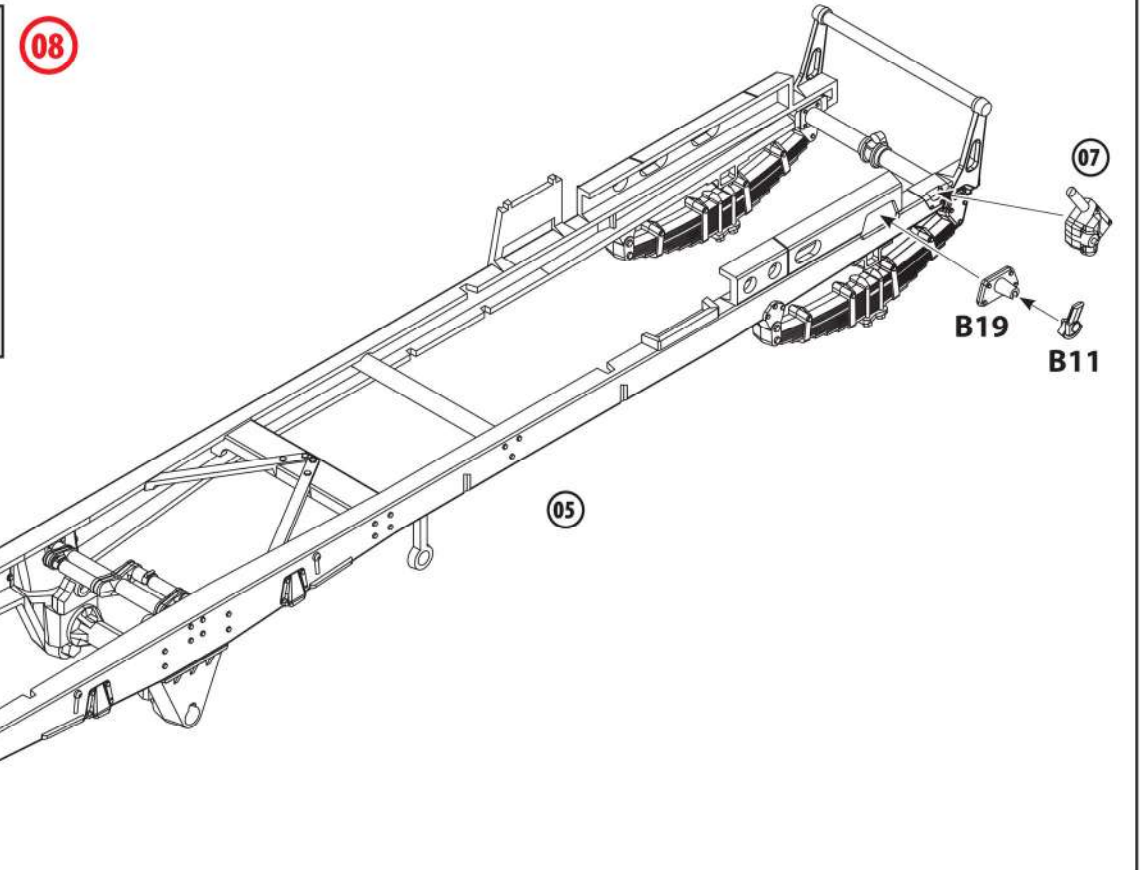
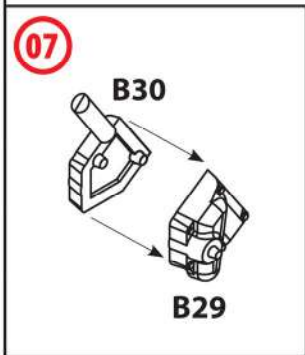
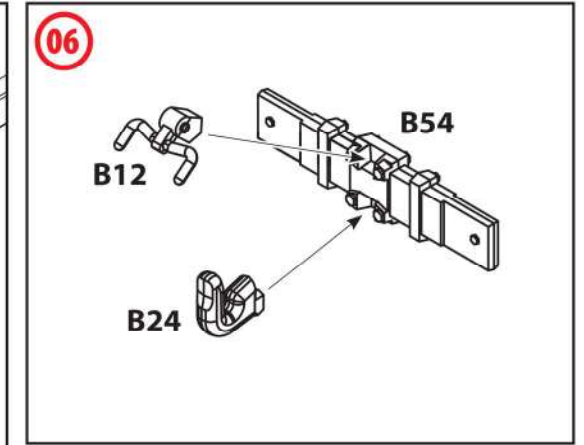
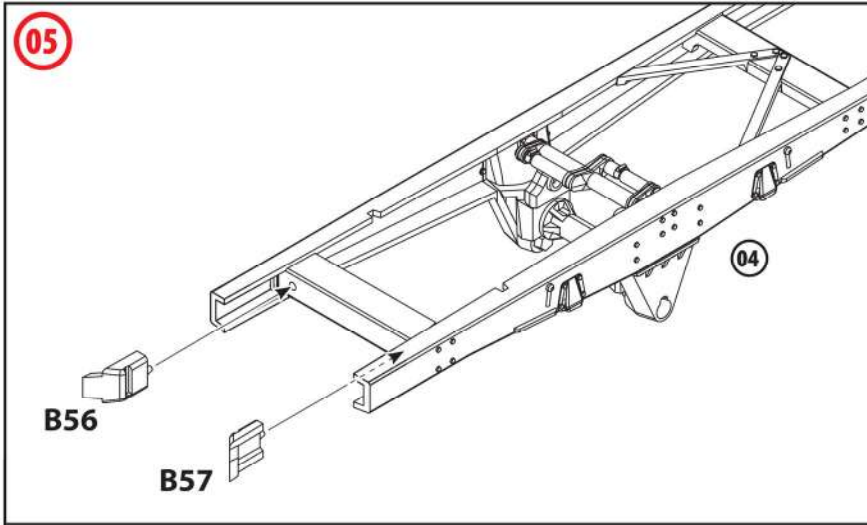

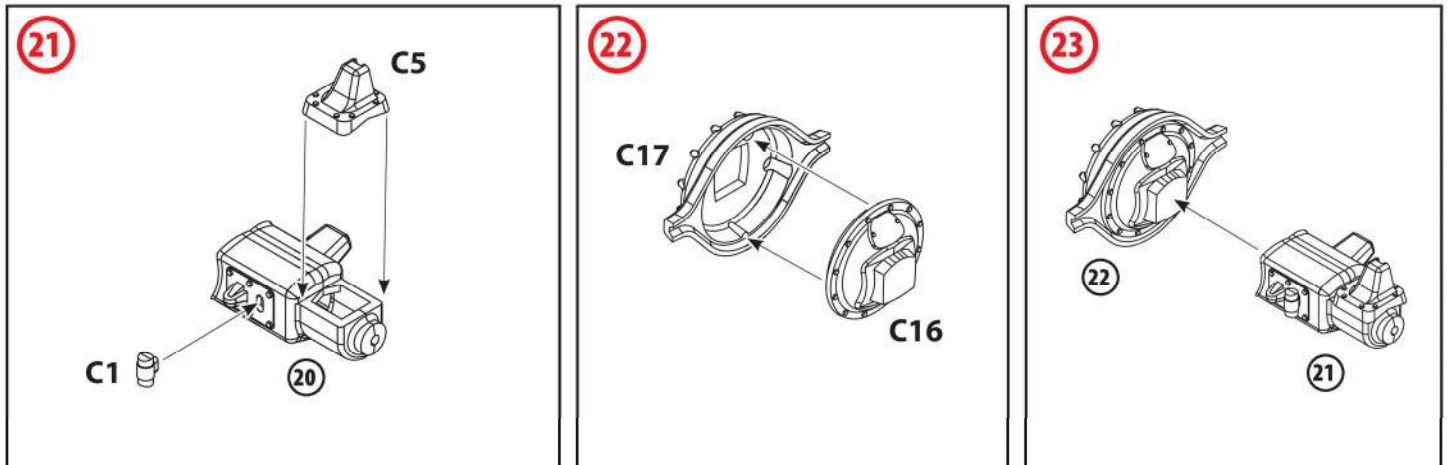
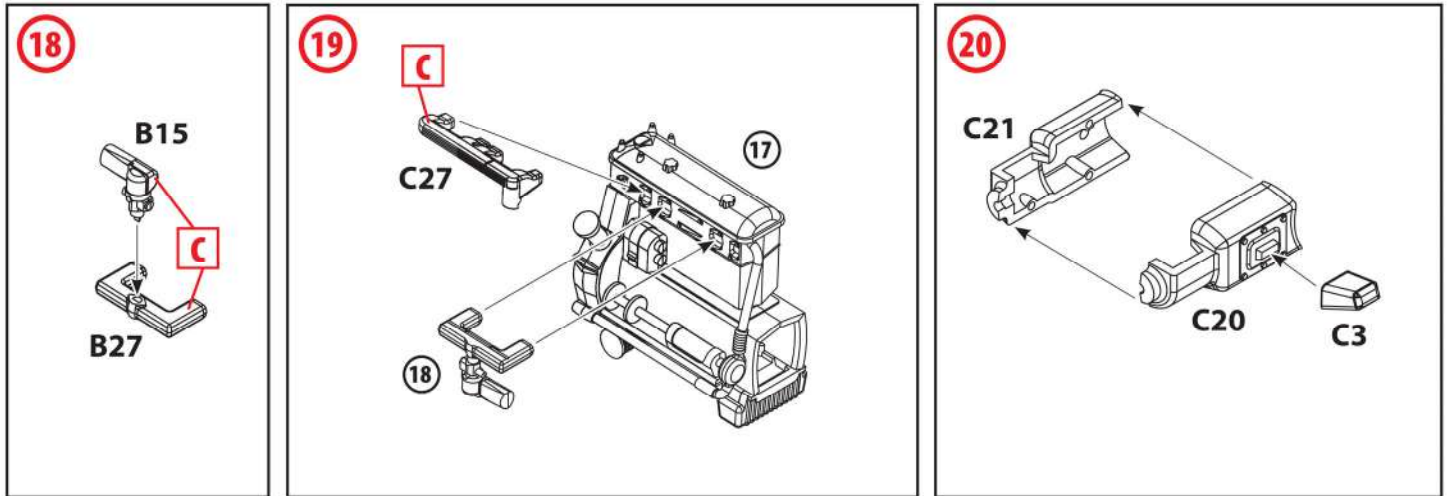
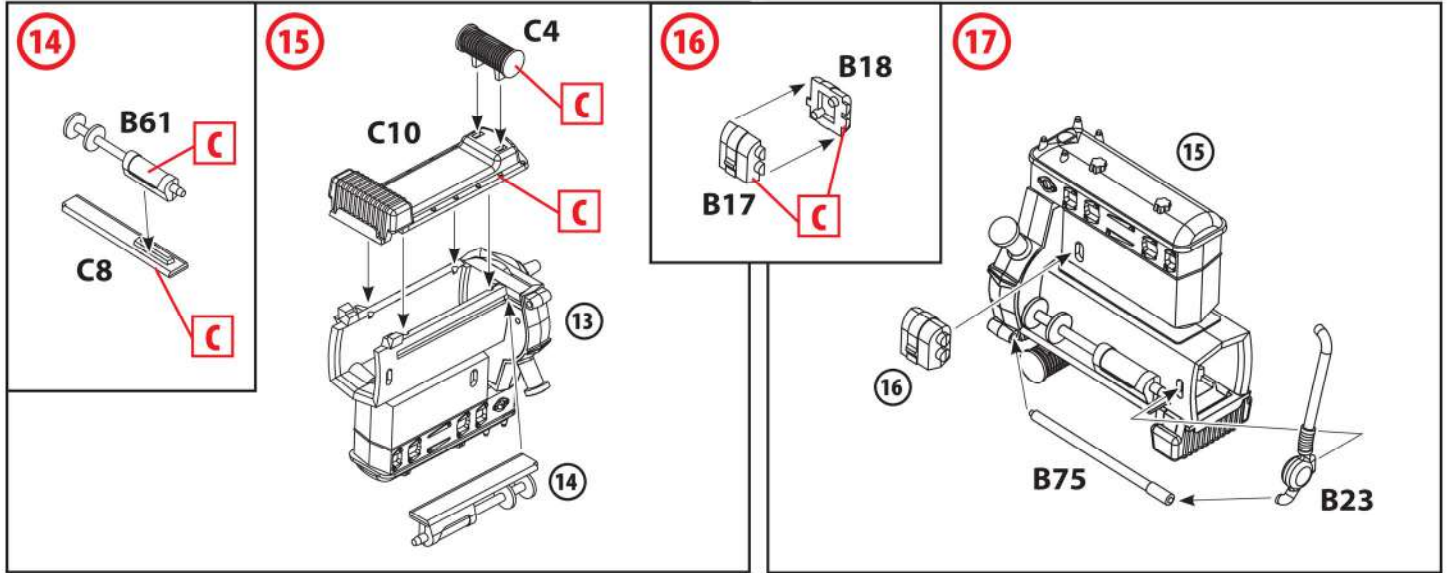
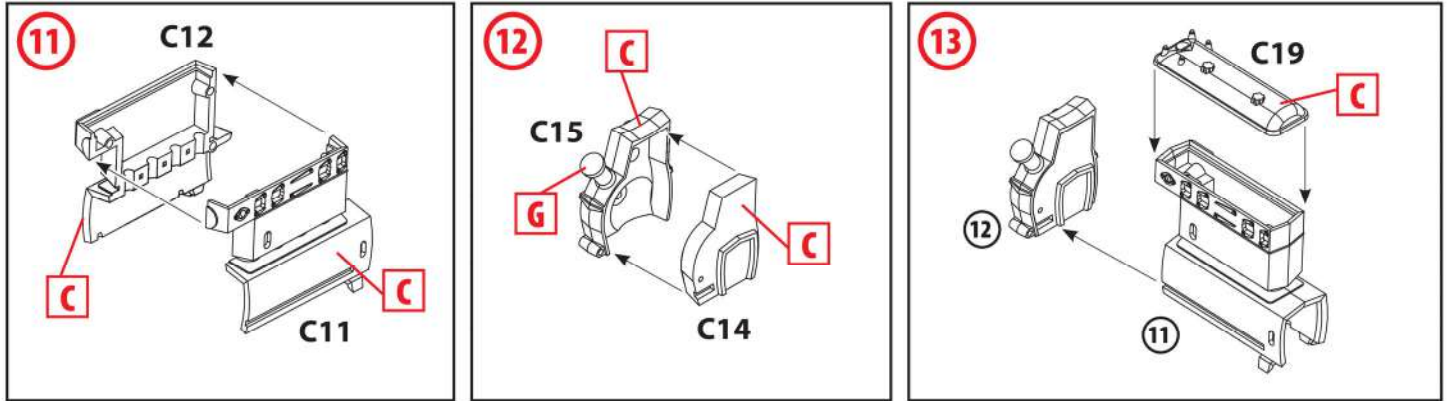

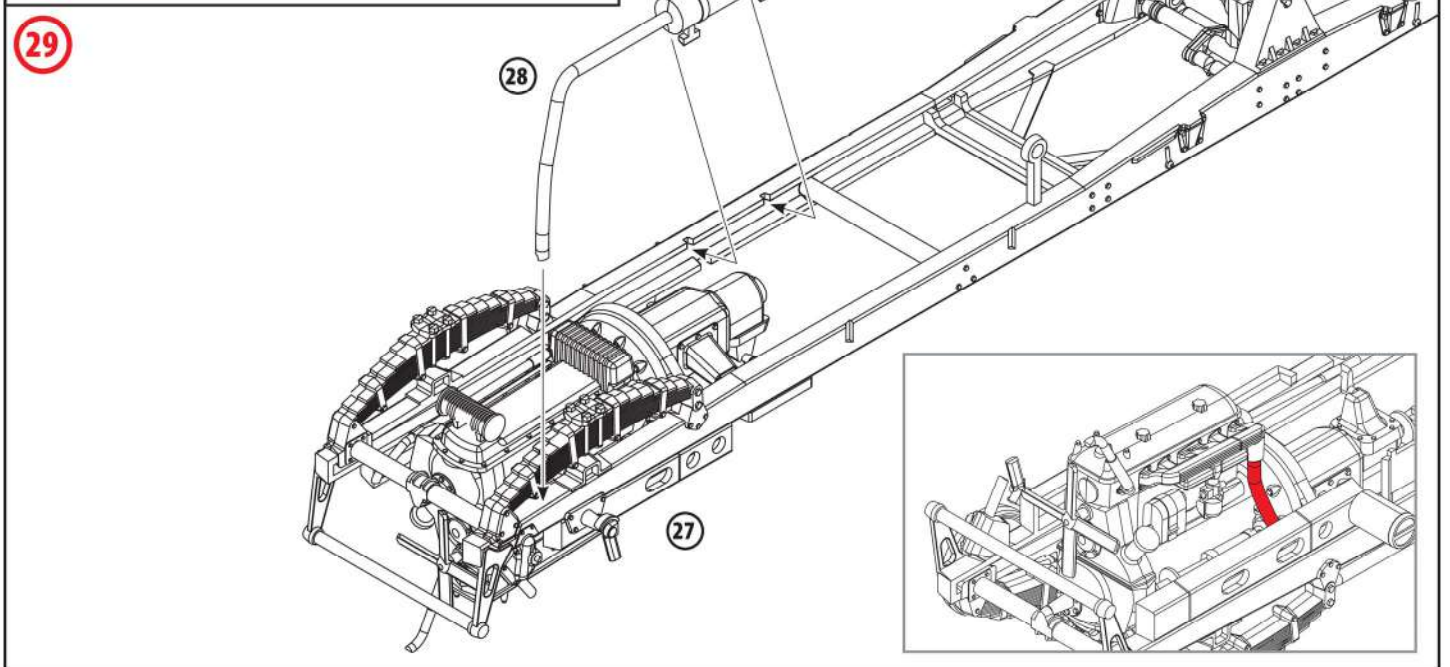
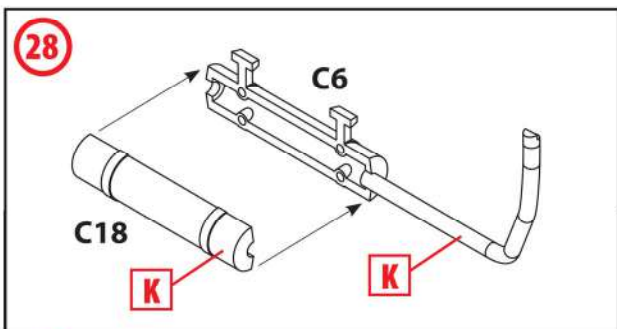
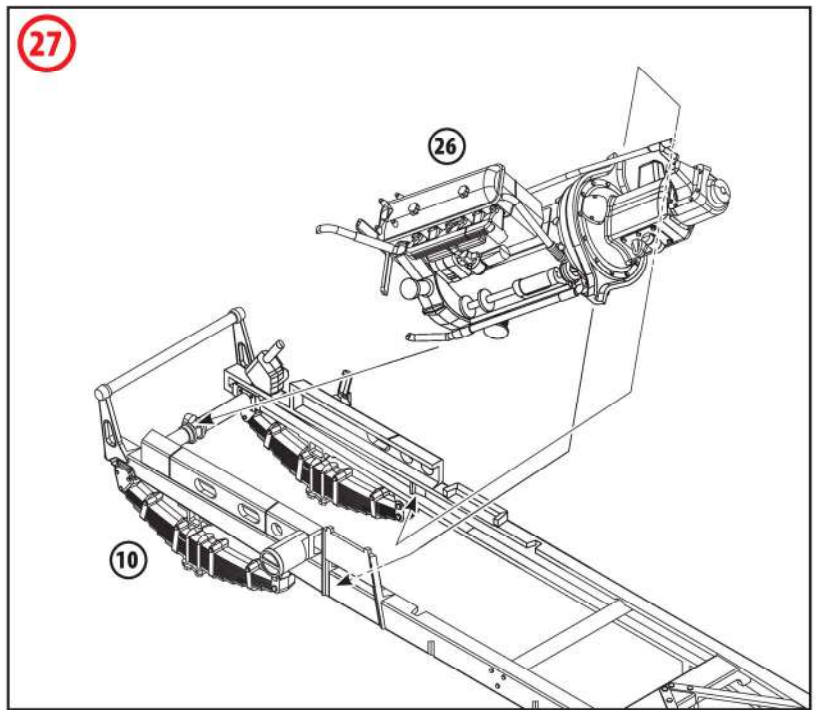
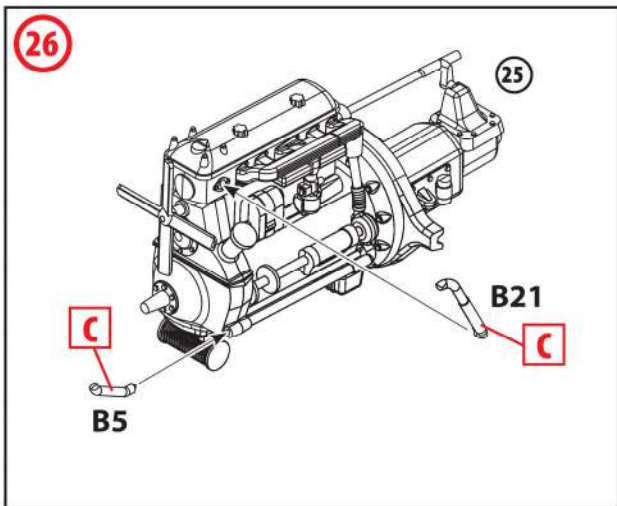
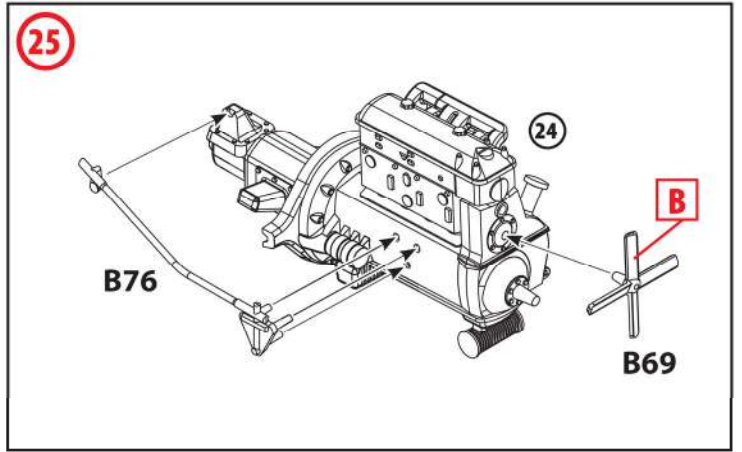
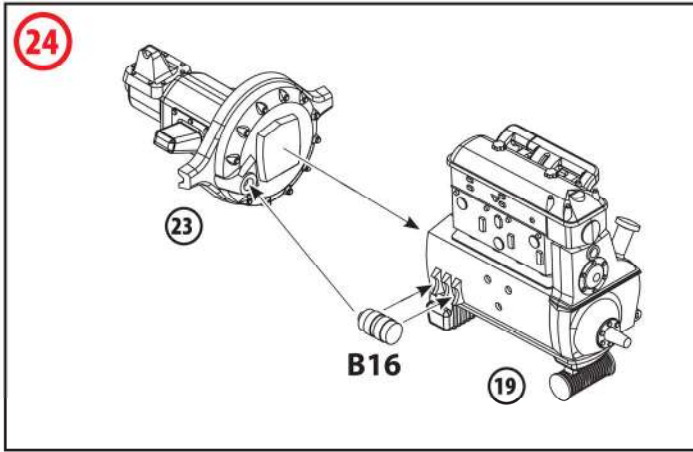

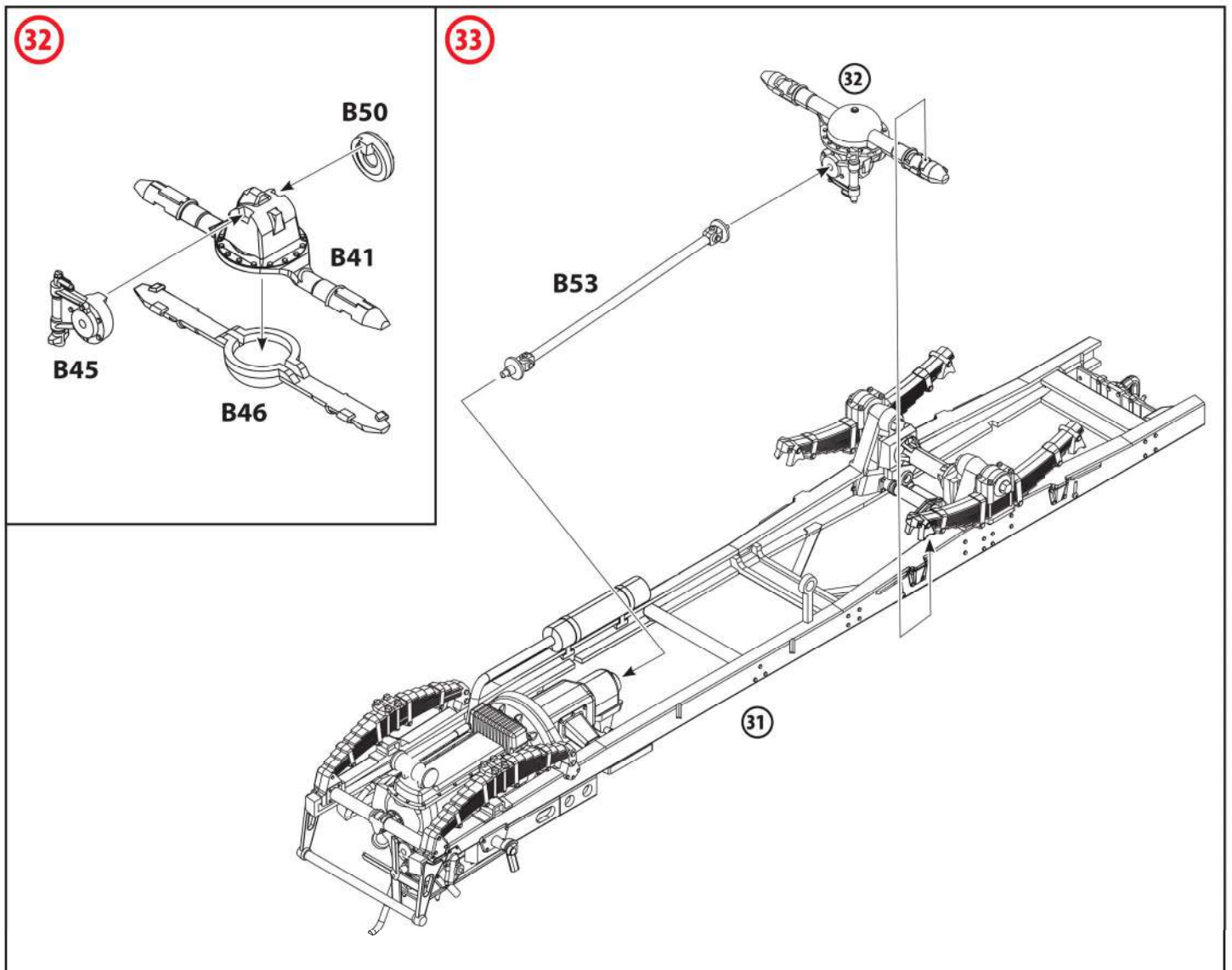
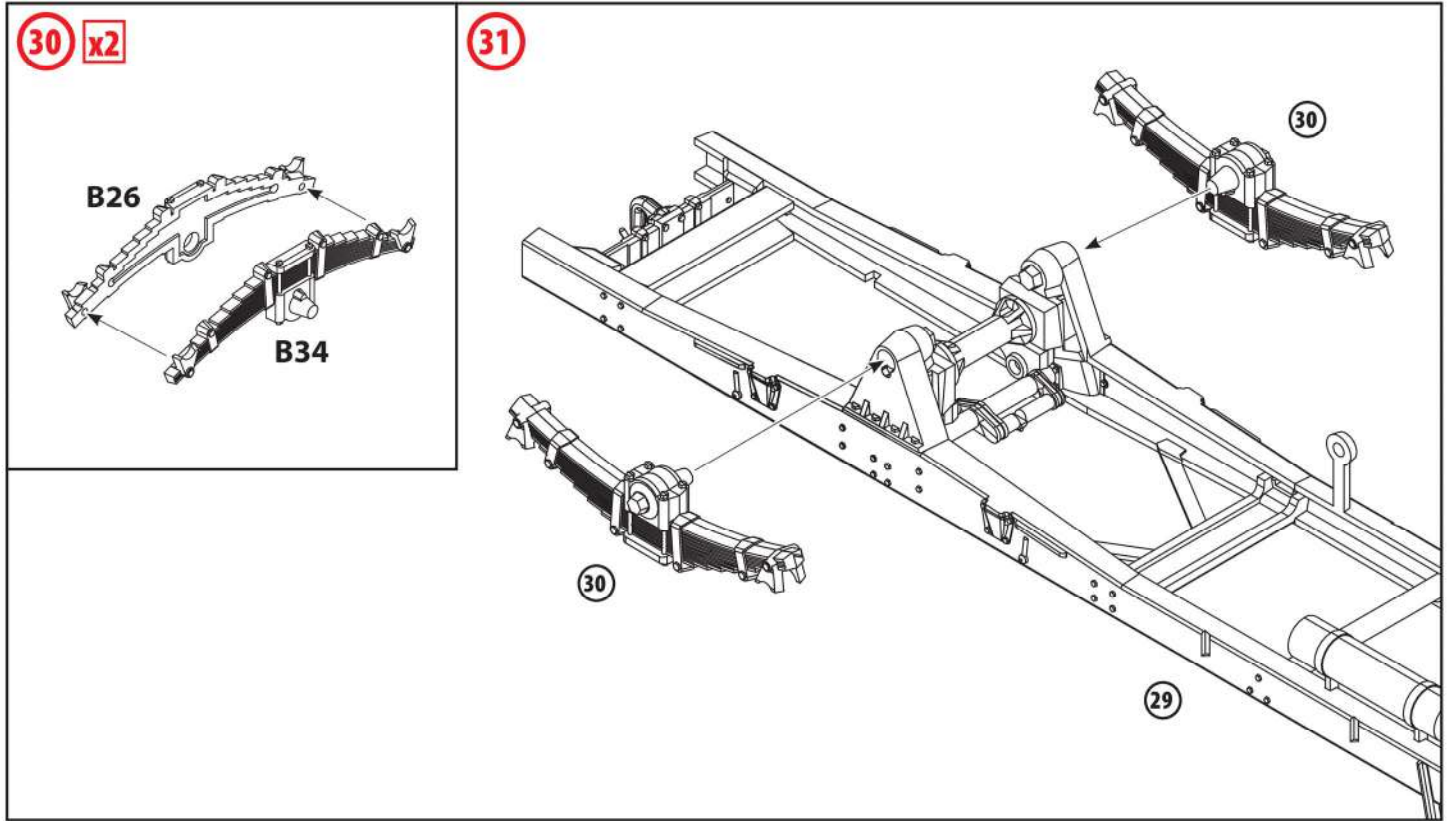

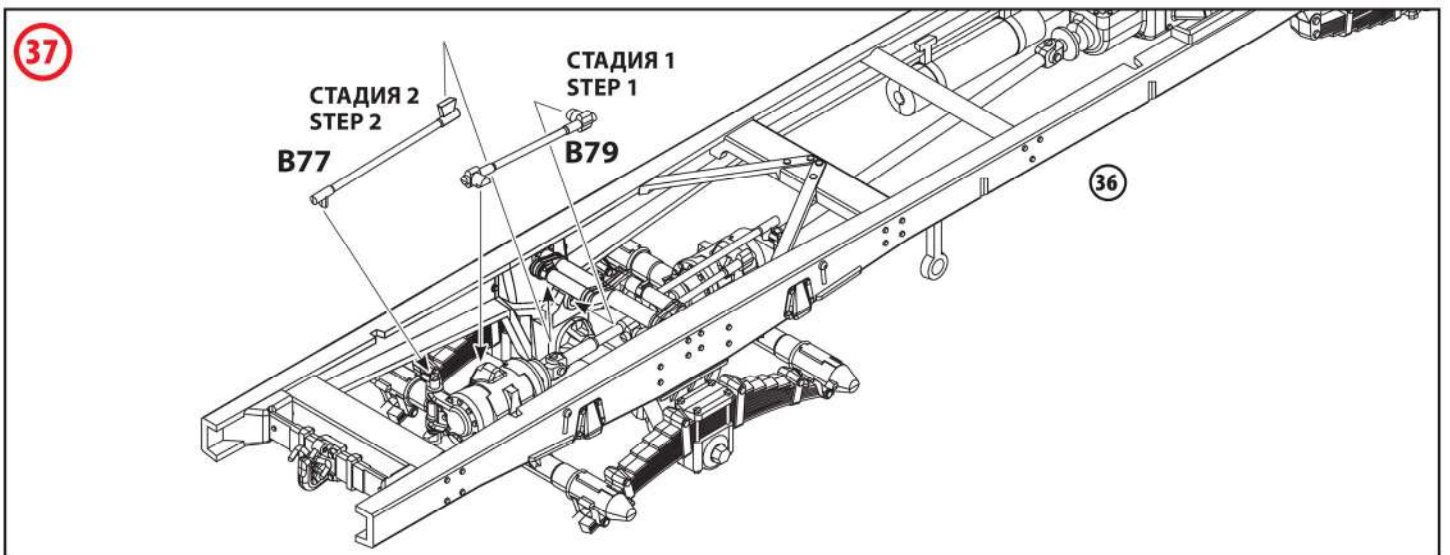
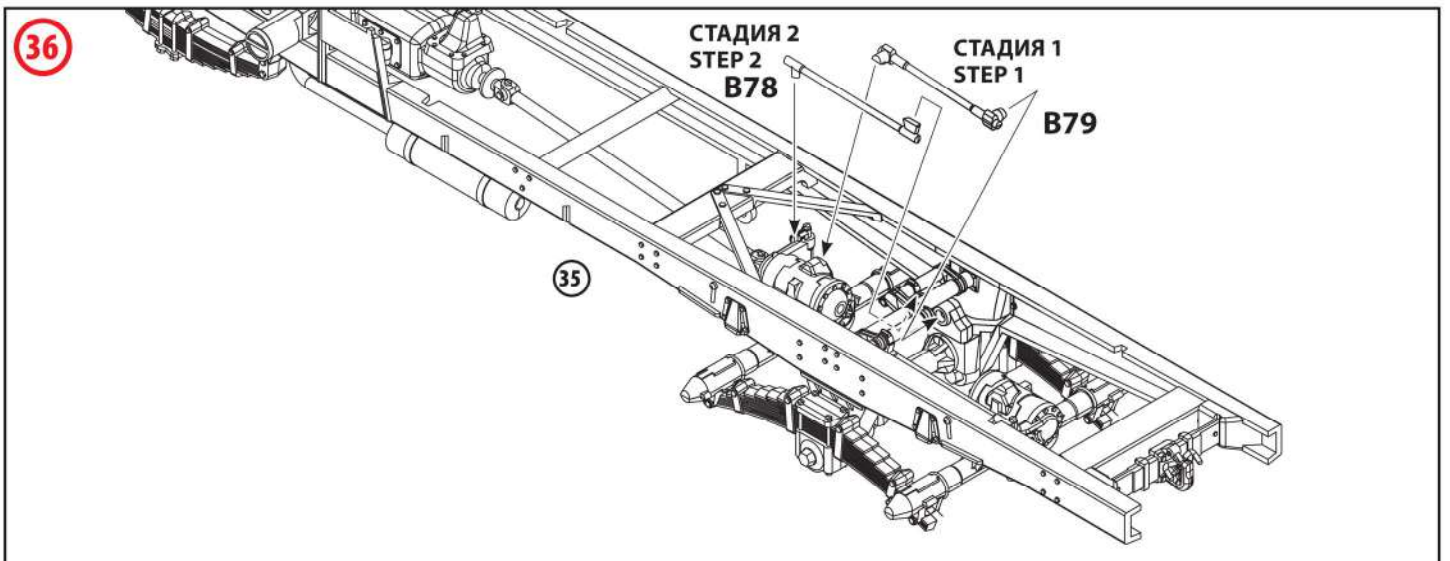
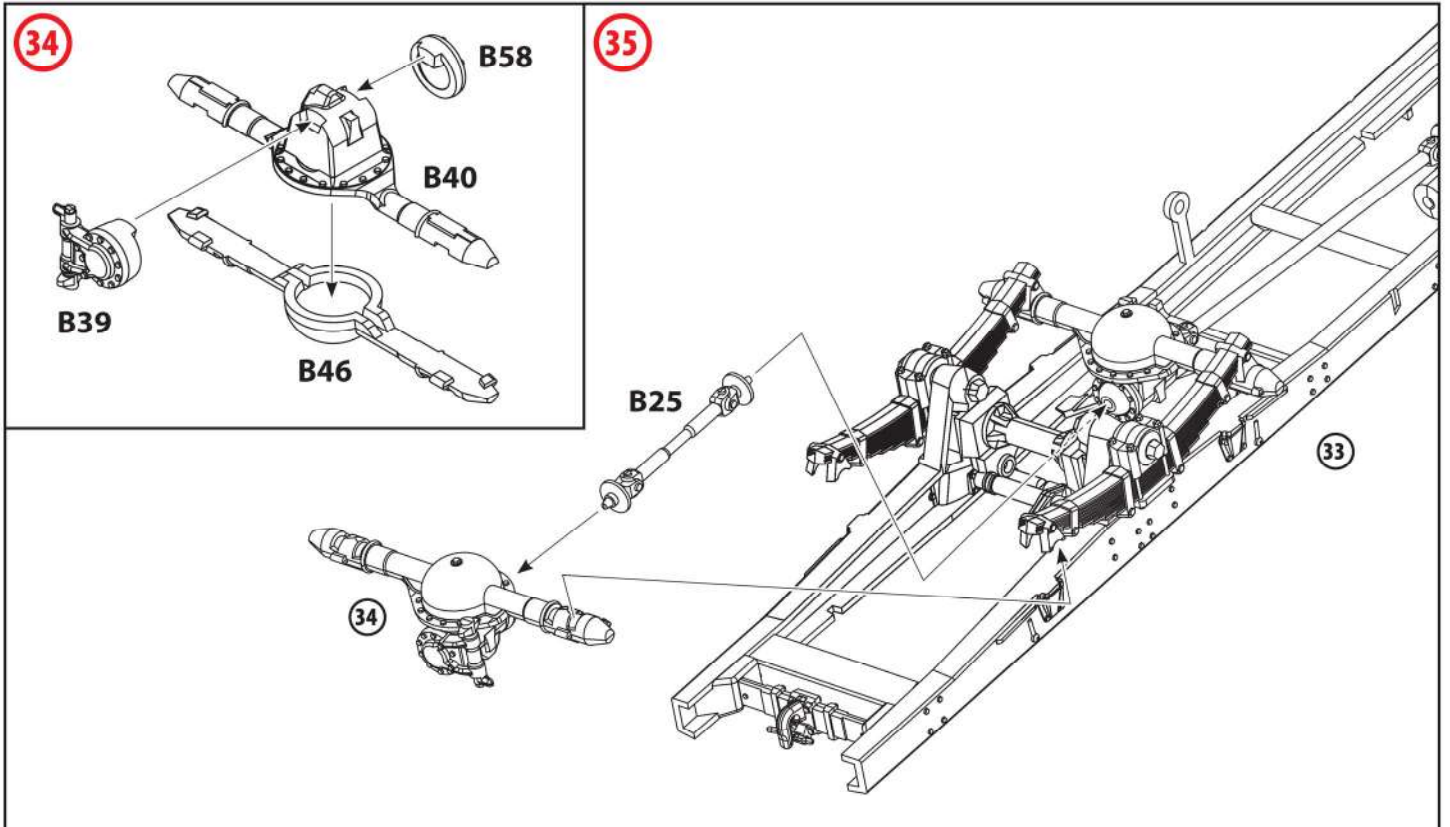

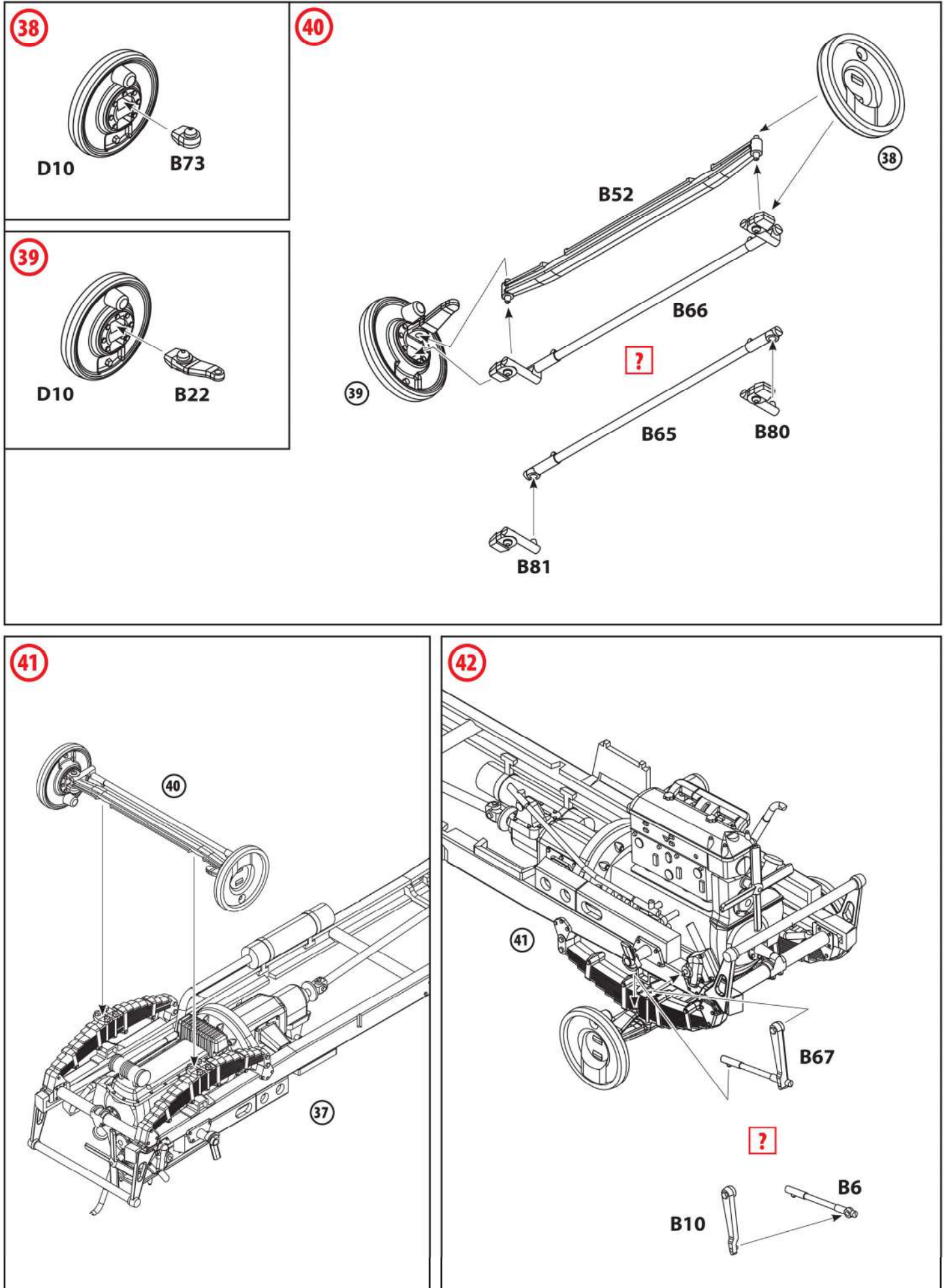

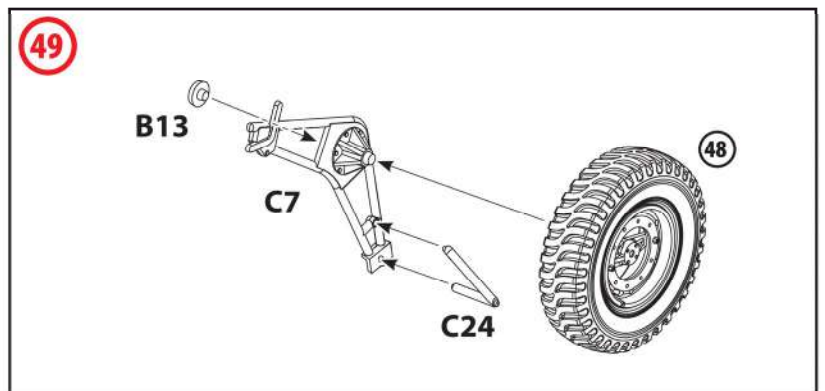
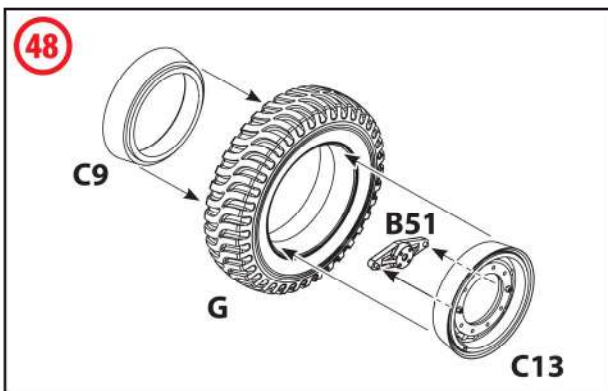
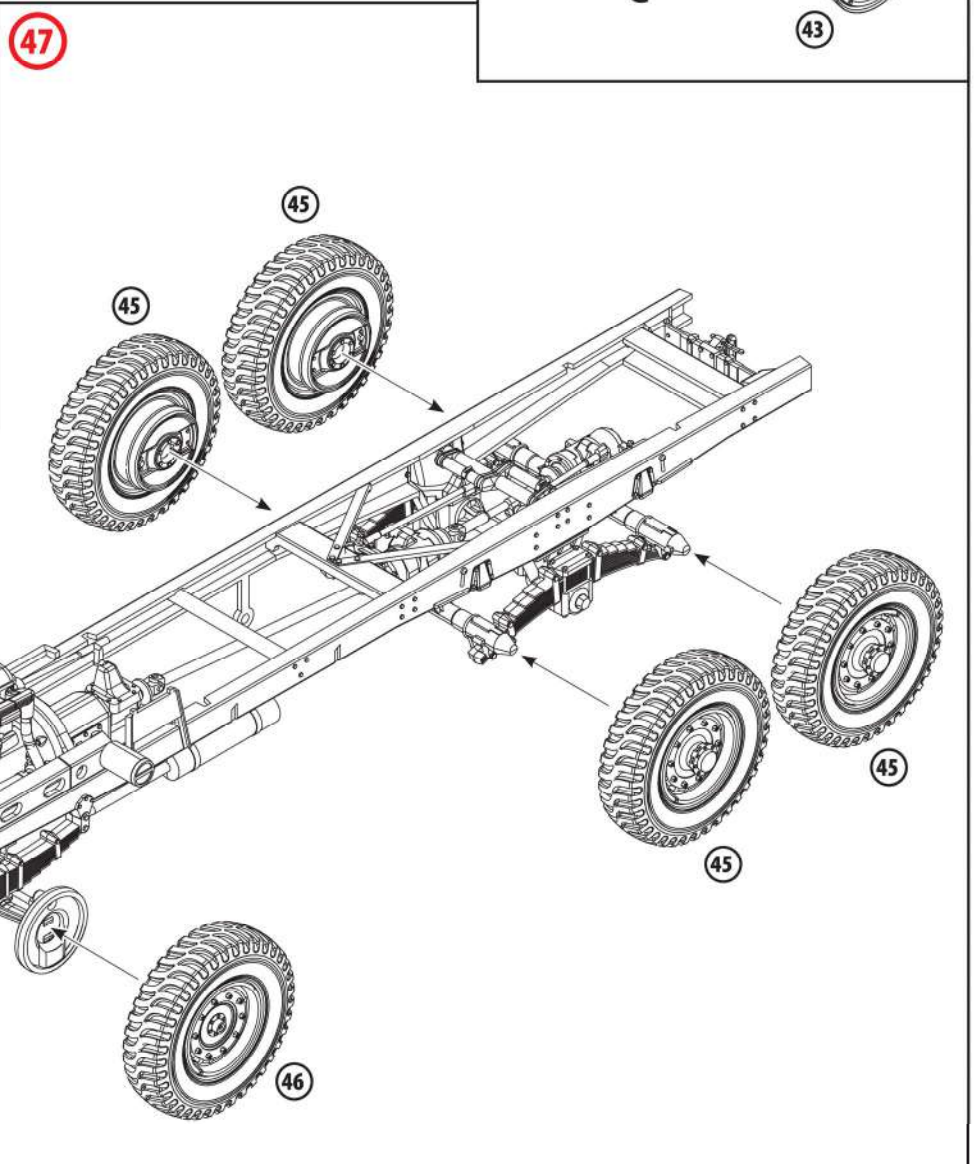
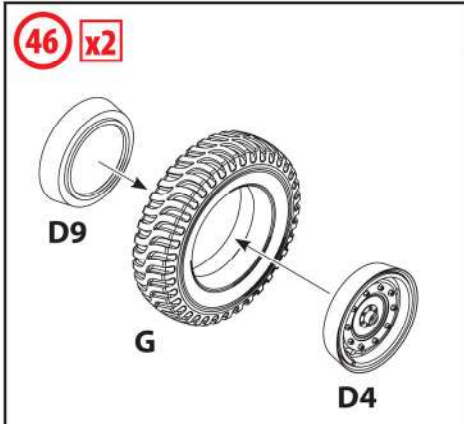
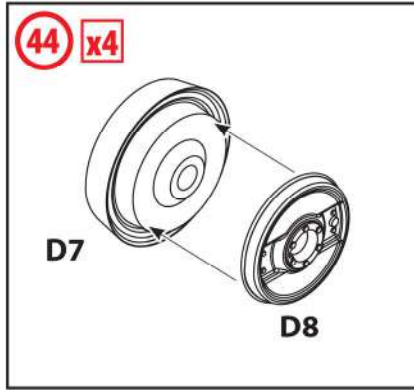
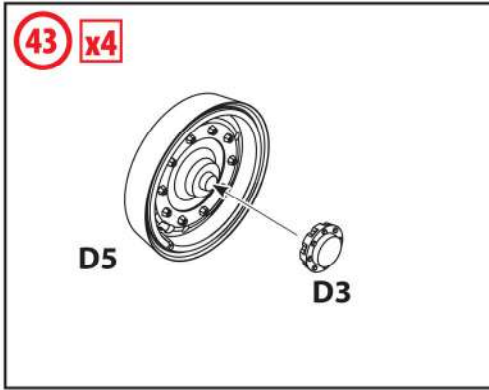

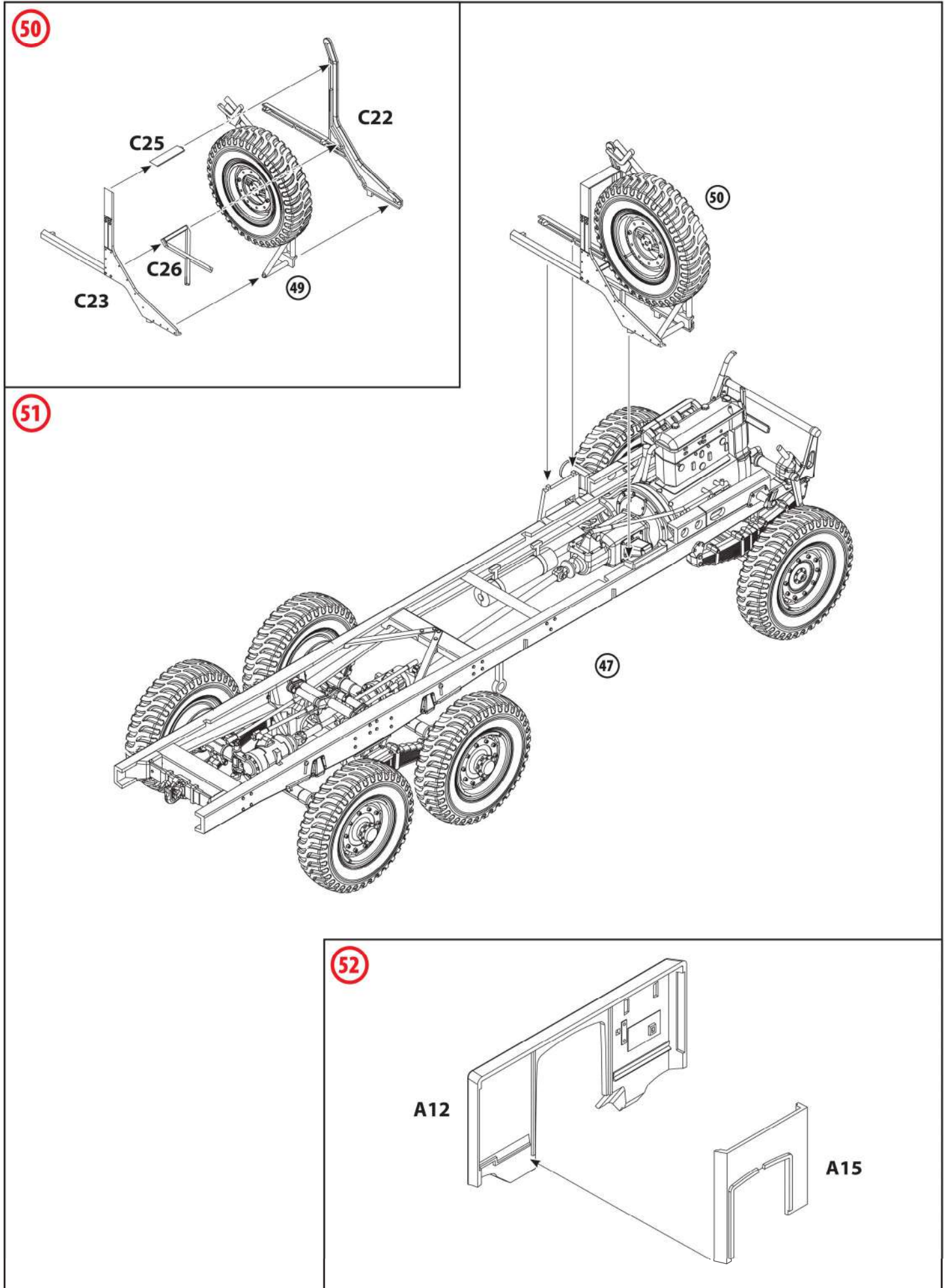

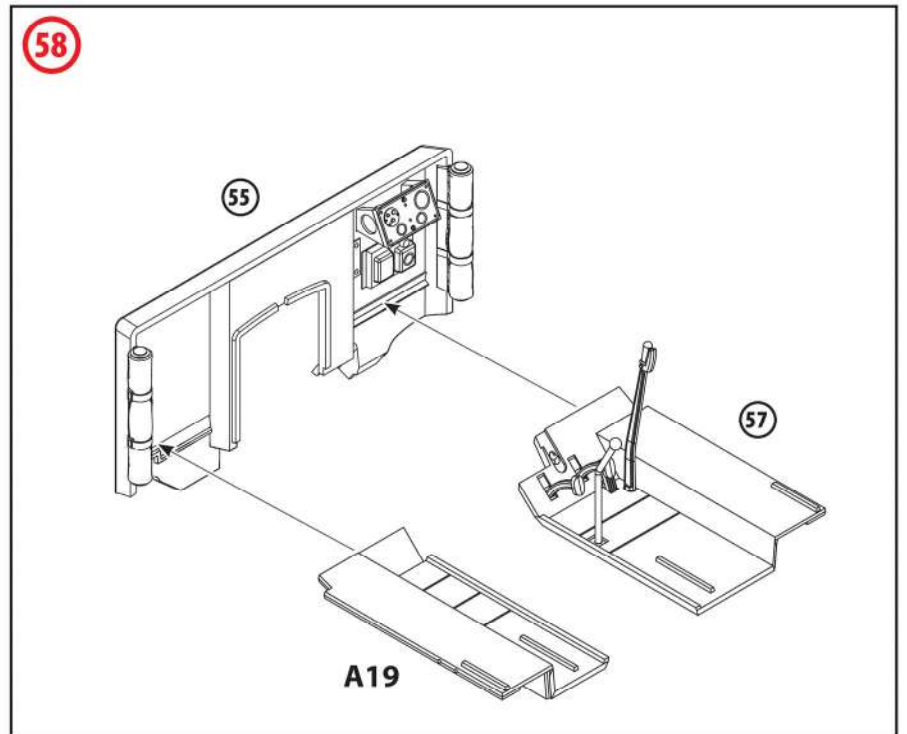
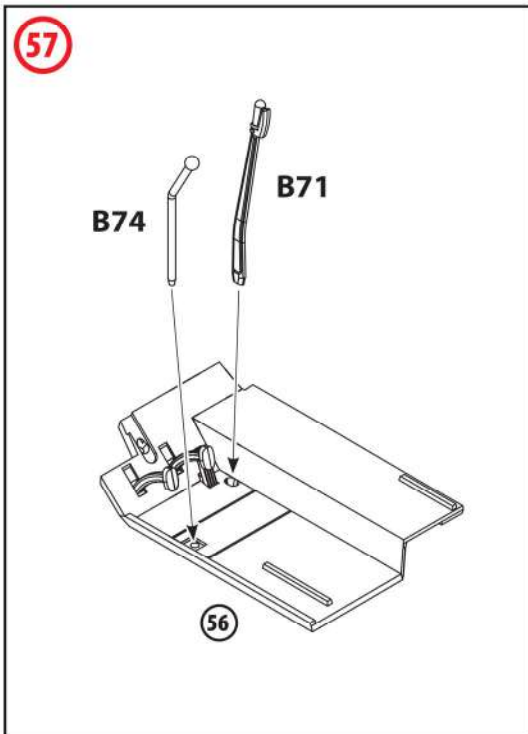
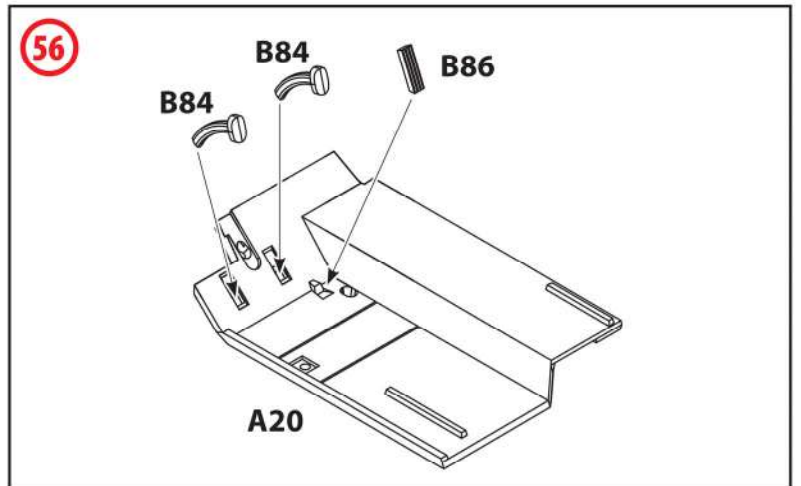
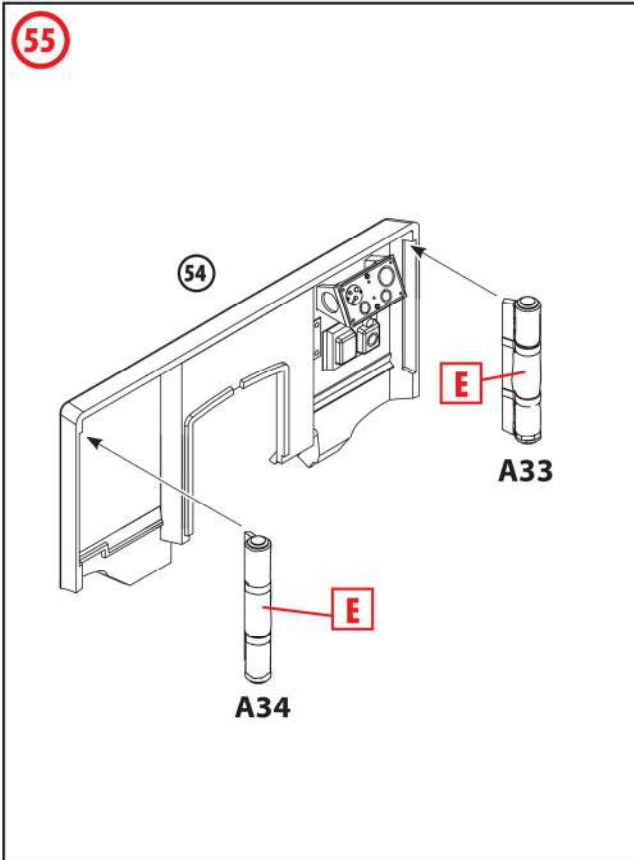
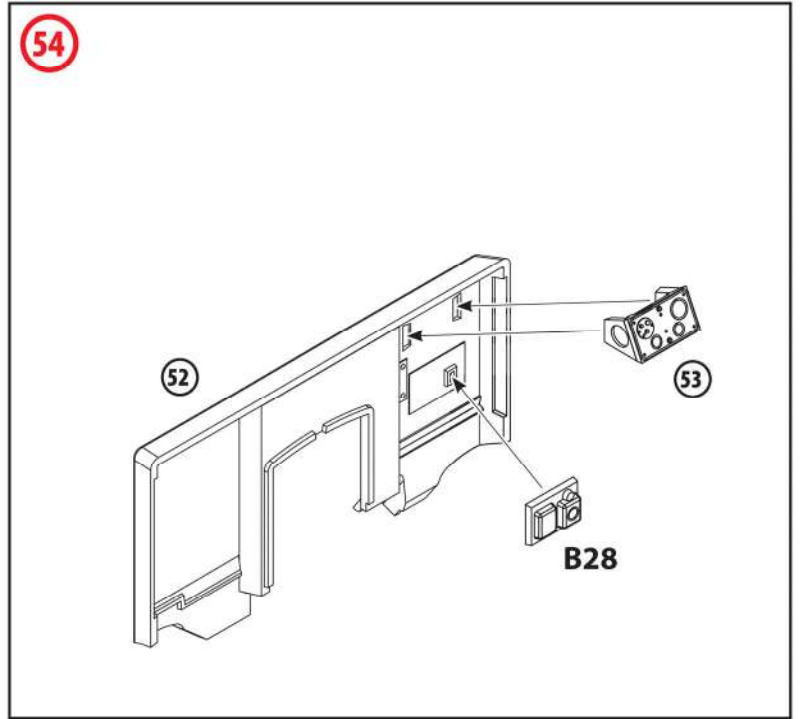
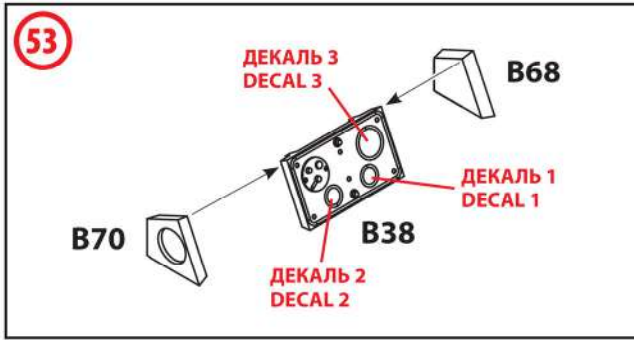

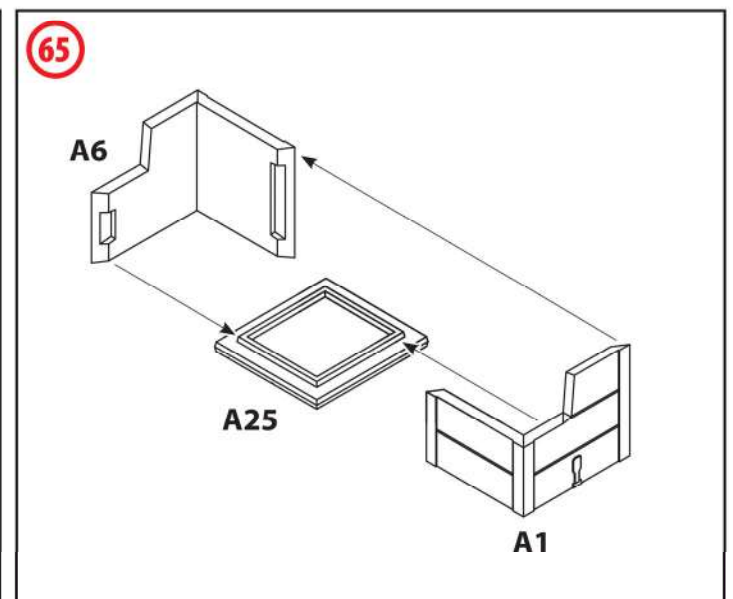
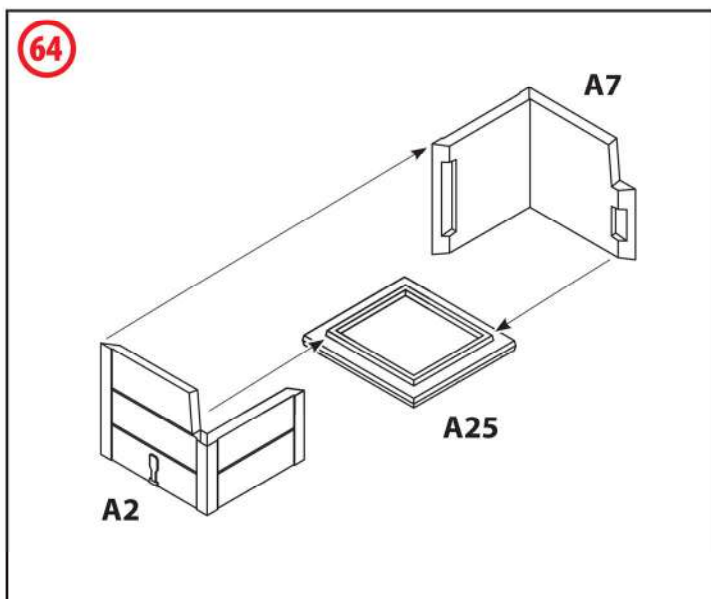
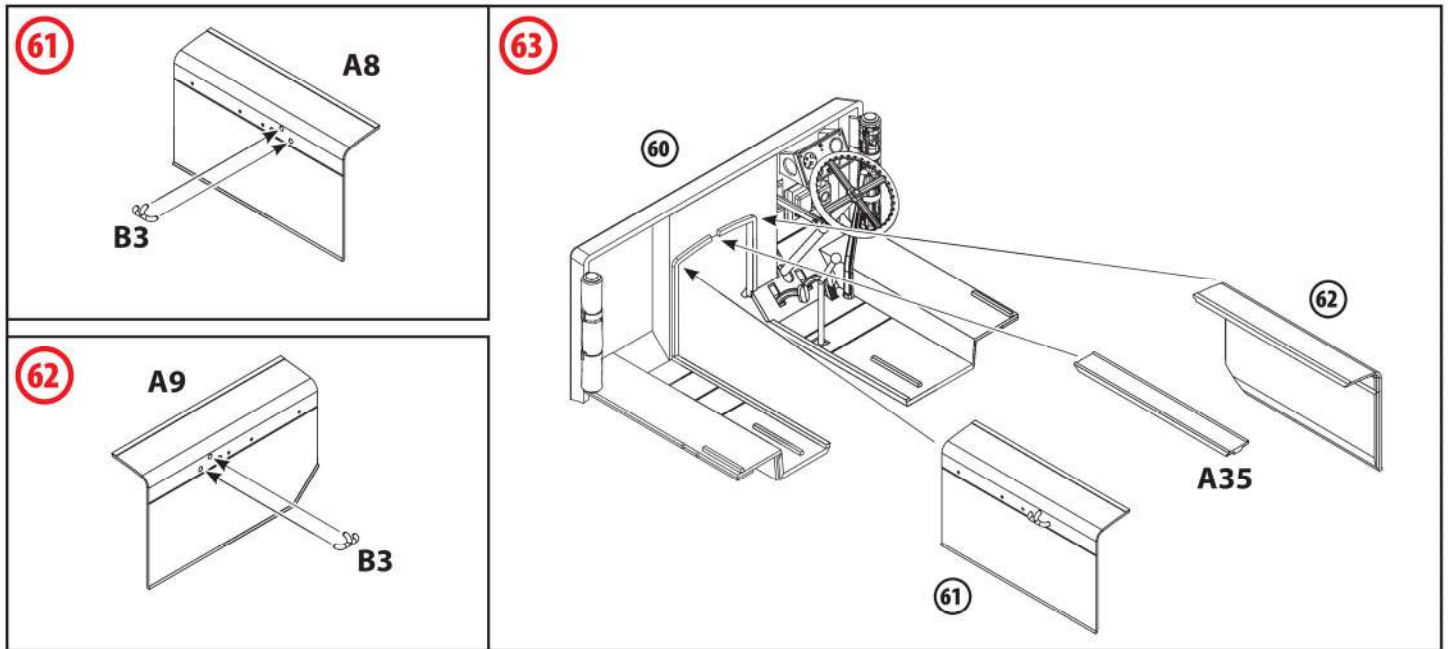
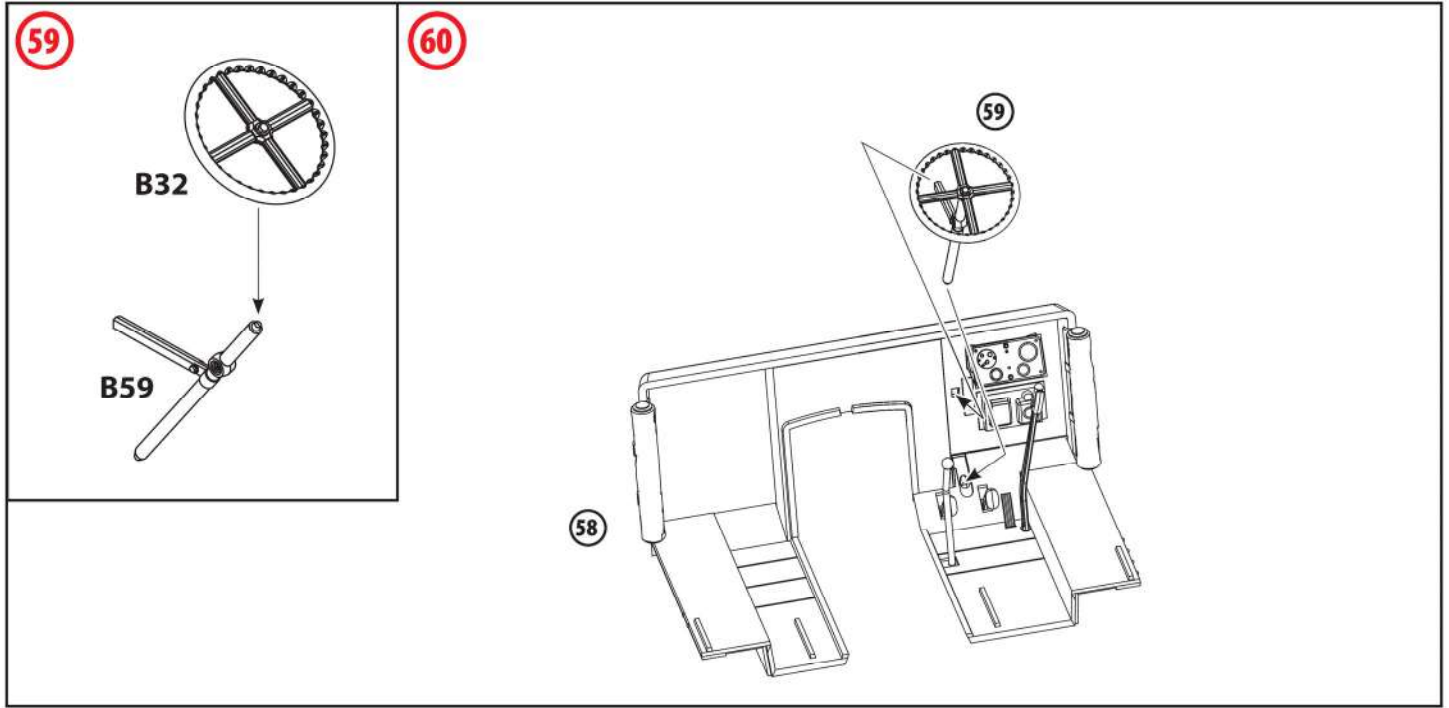

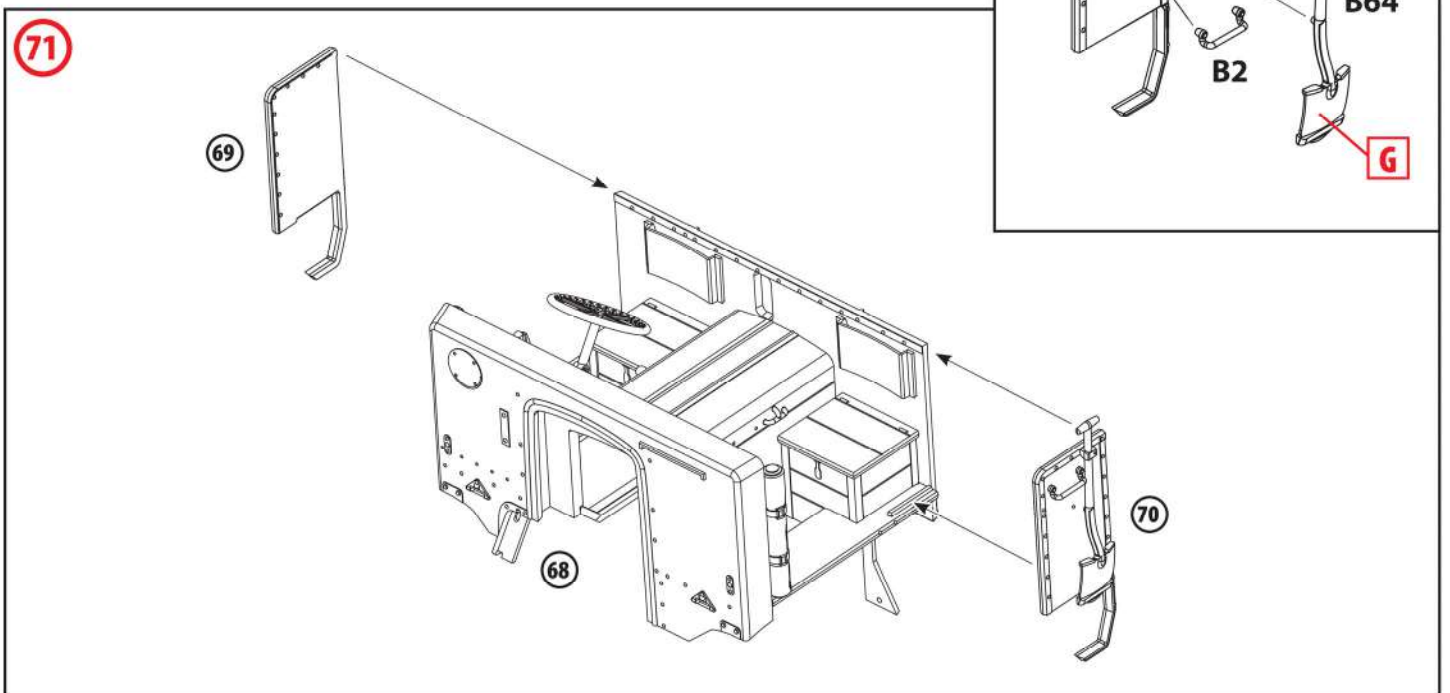
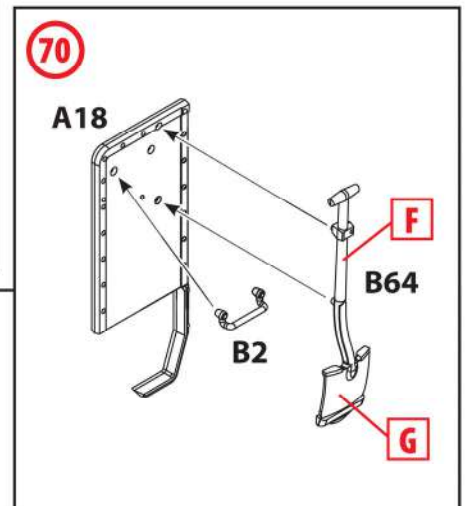
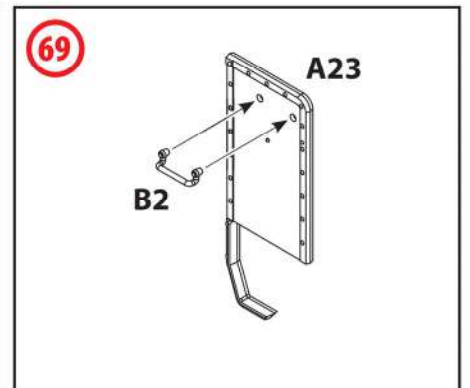
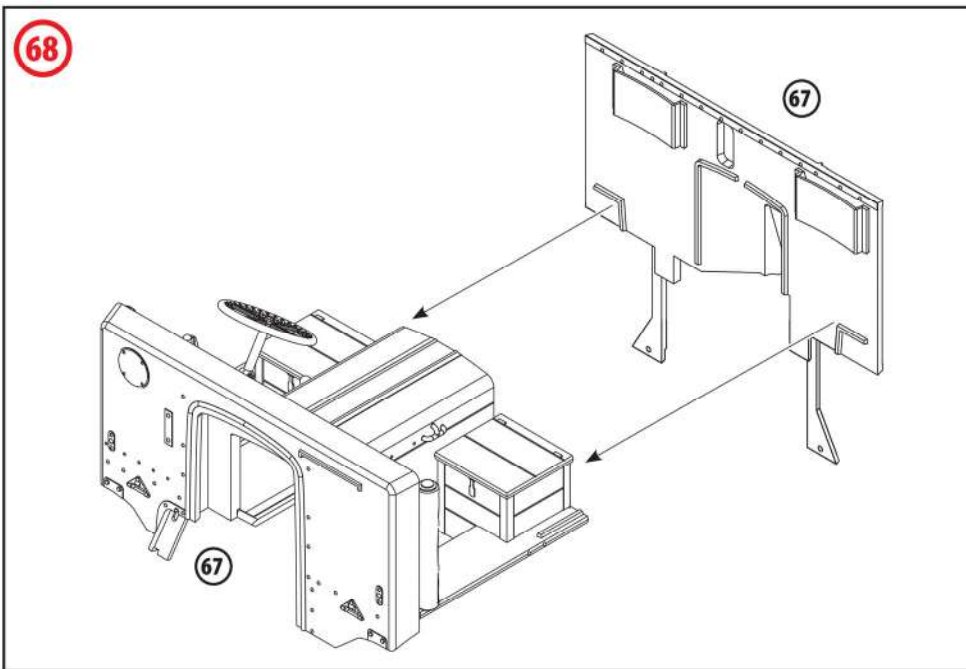
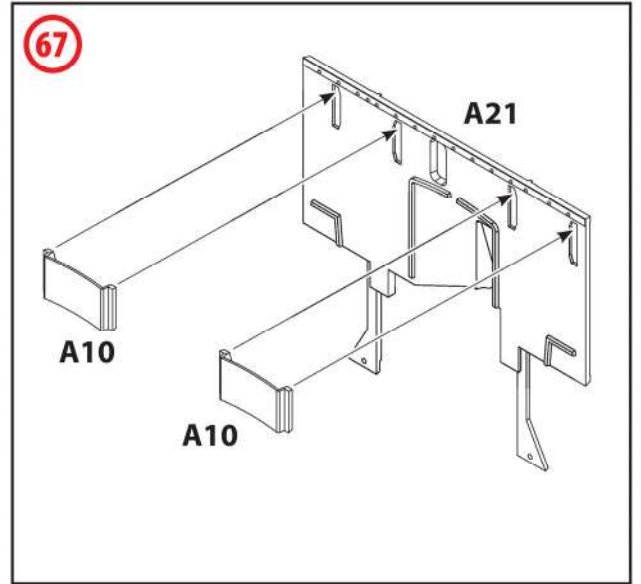
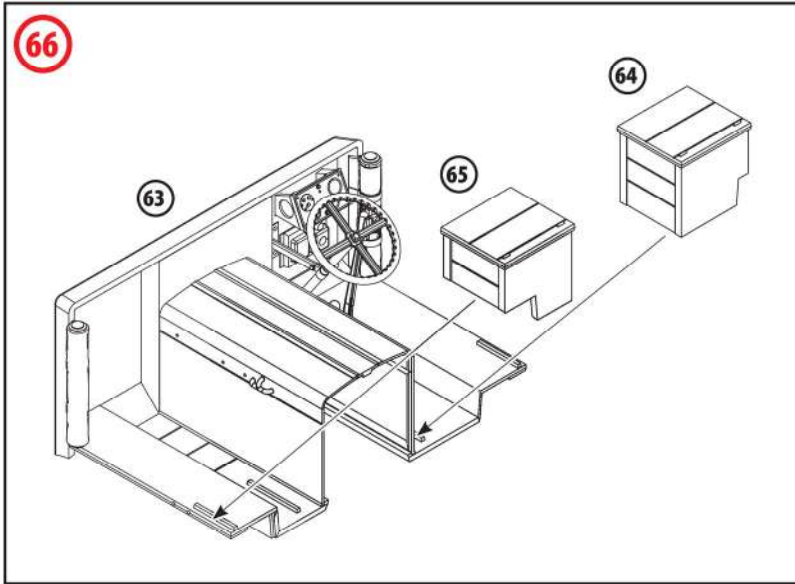

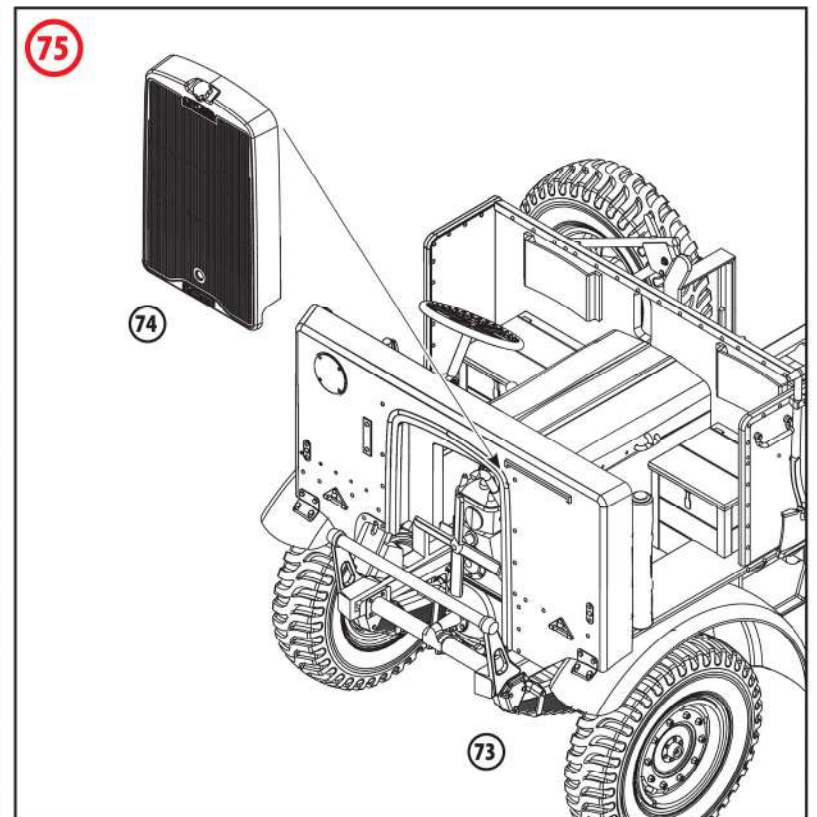
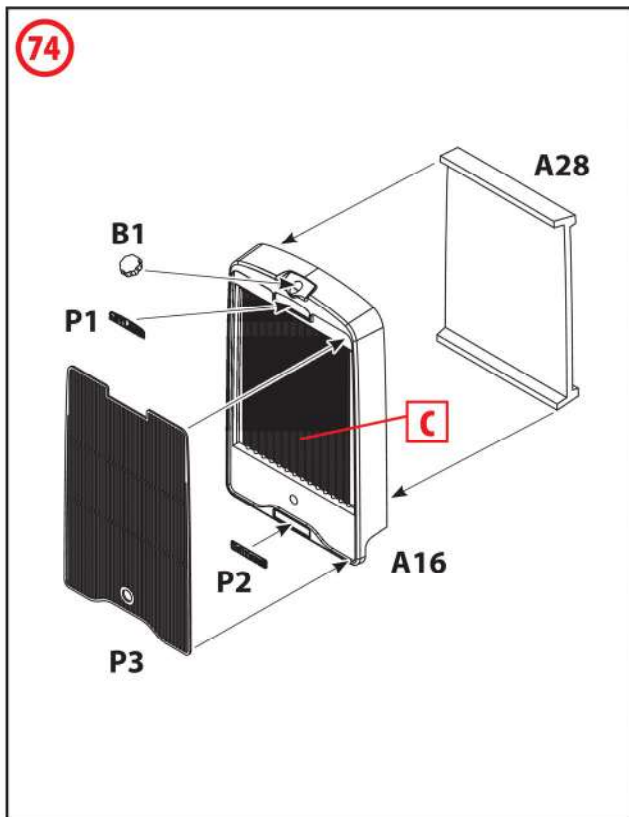
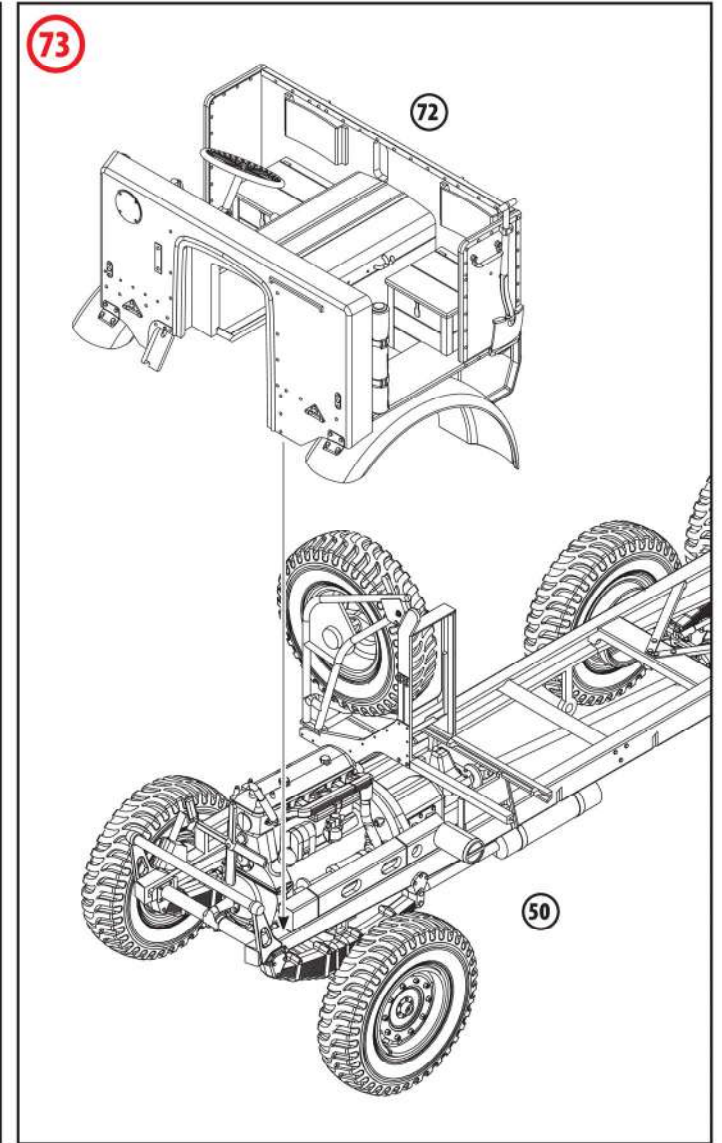
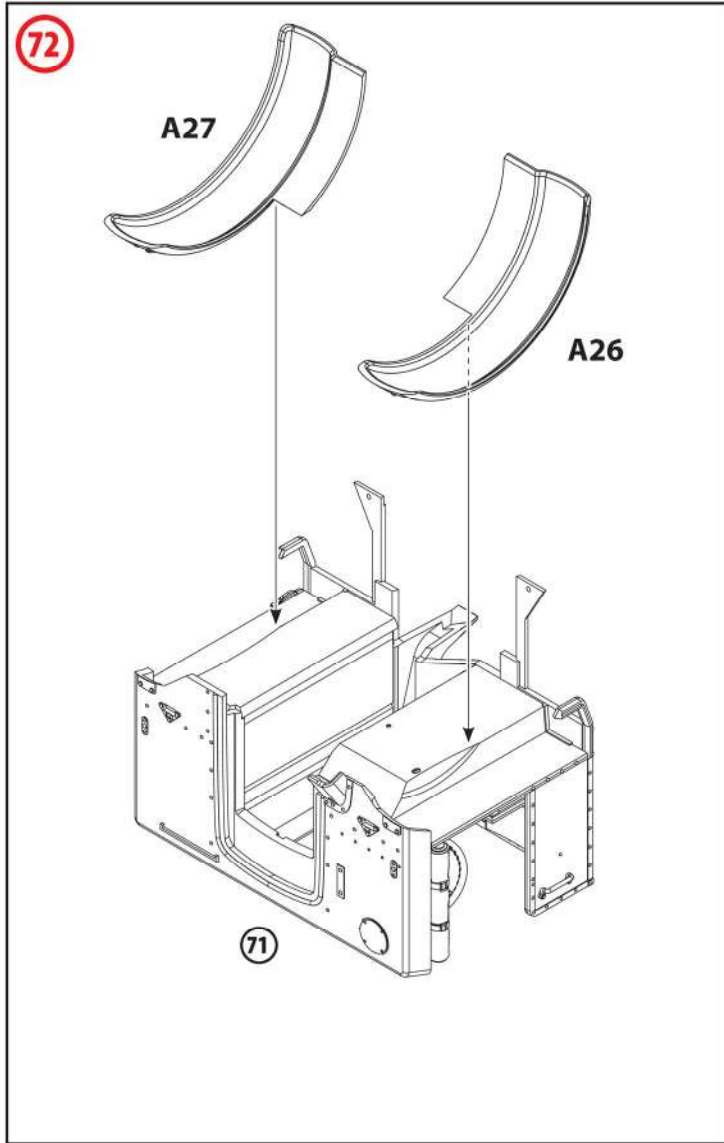

76

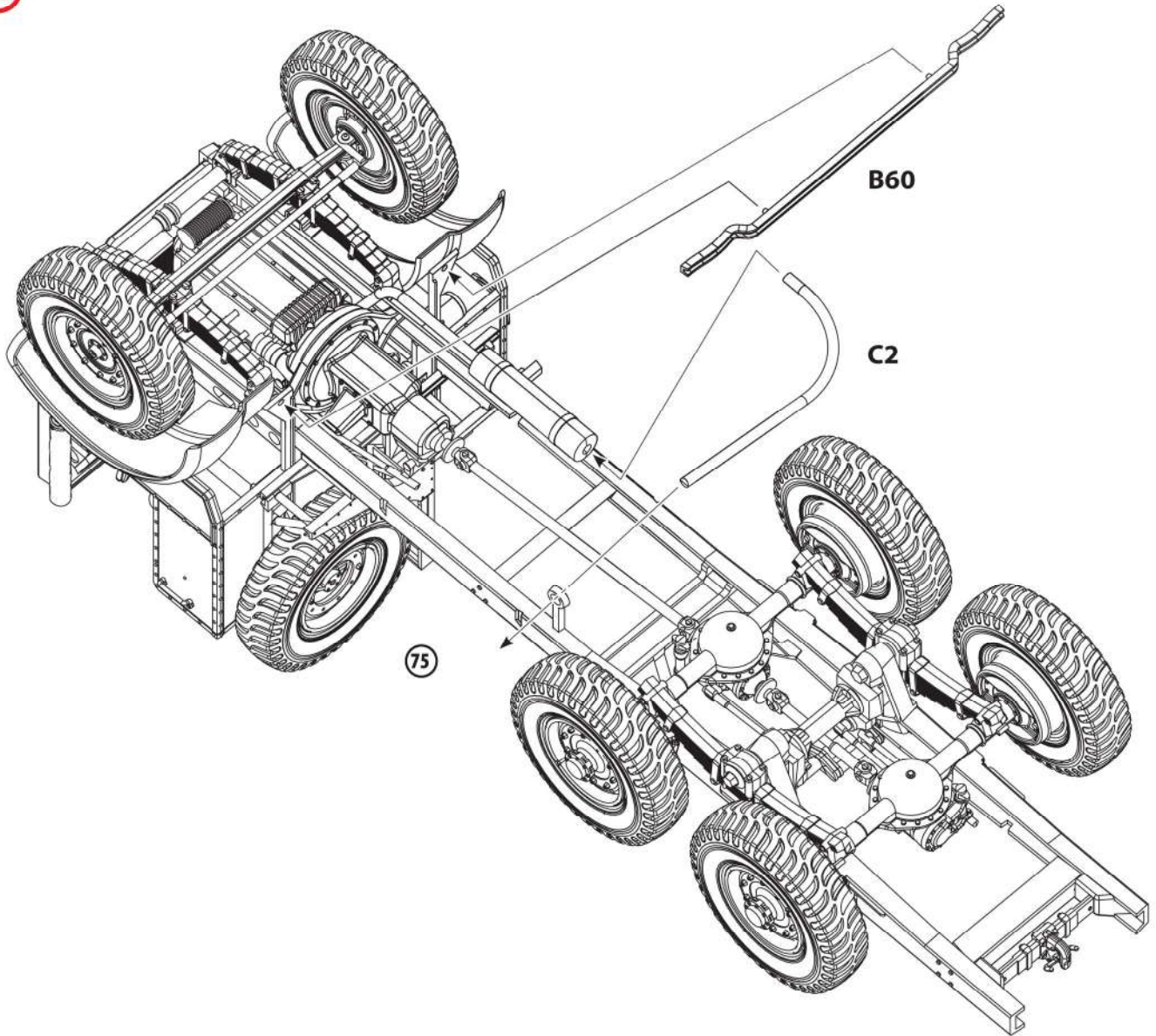

78

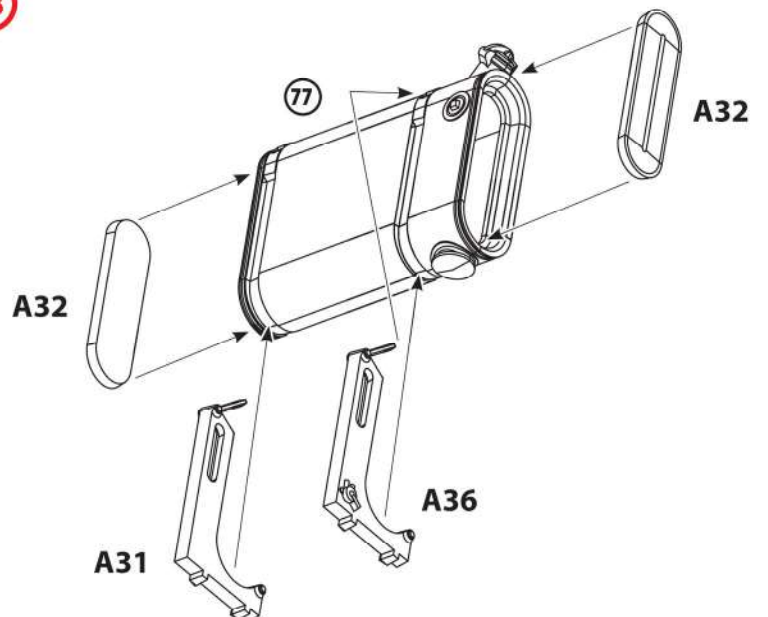

77

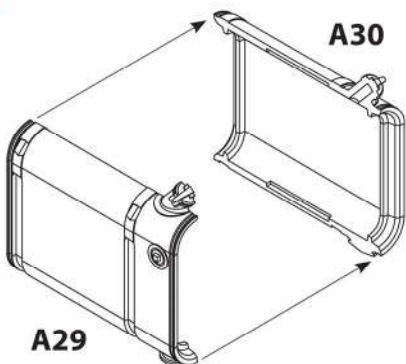

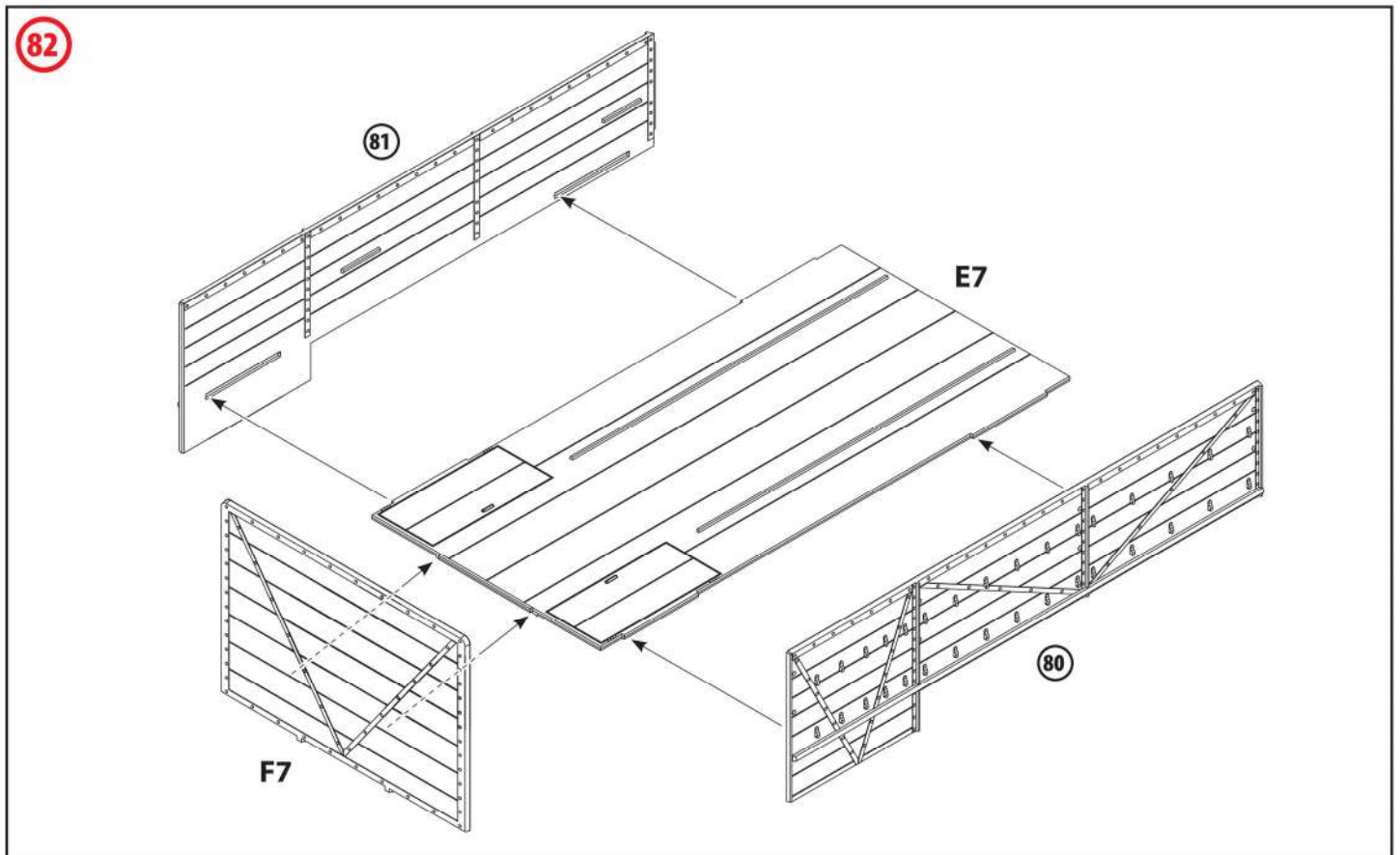
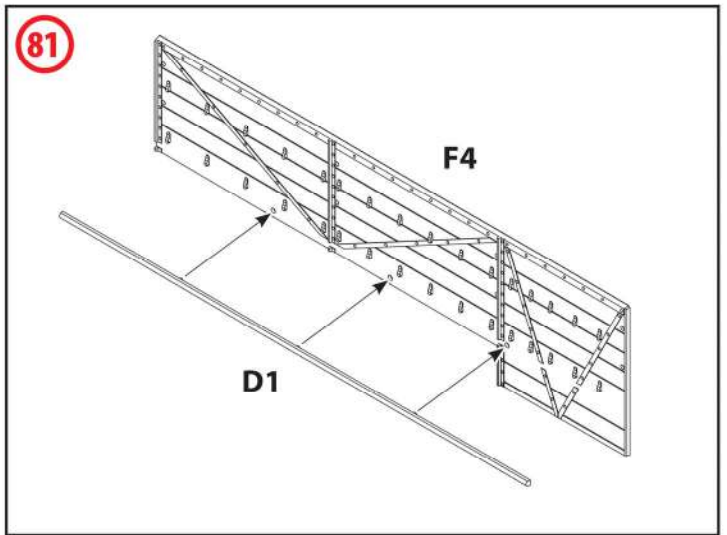
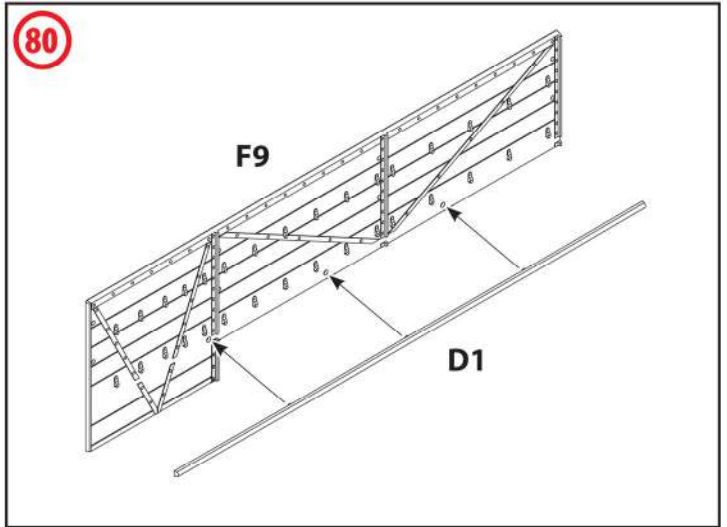
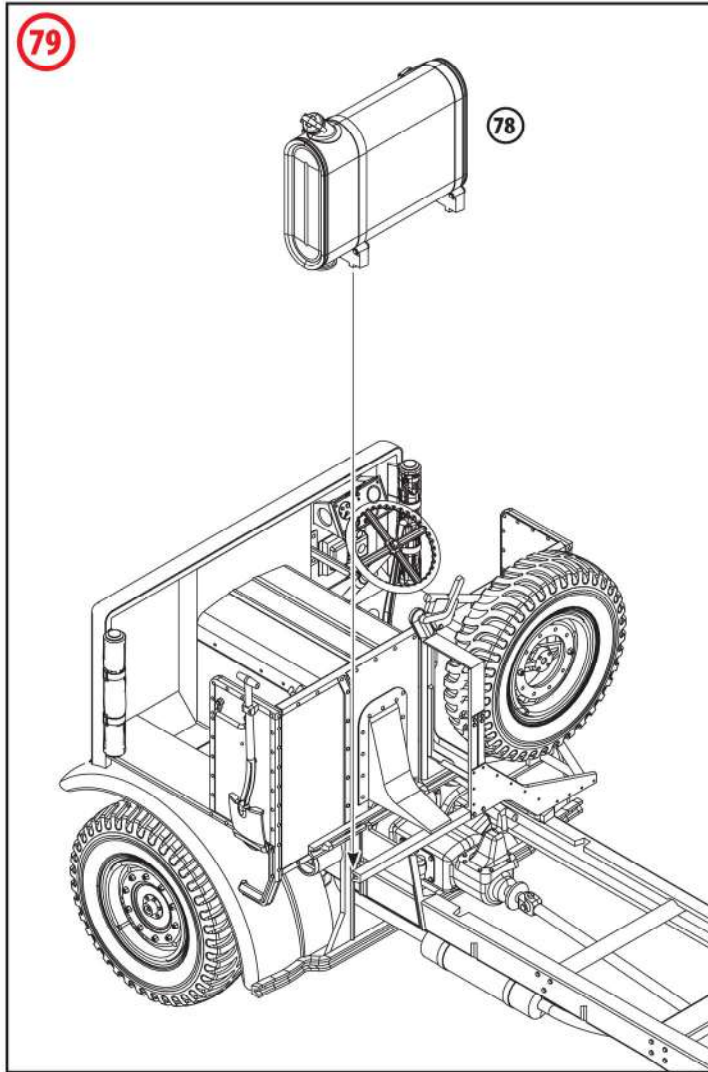

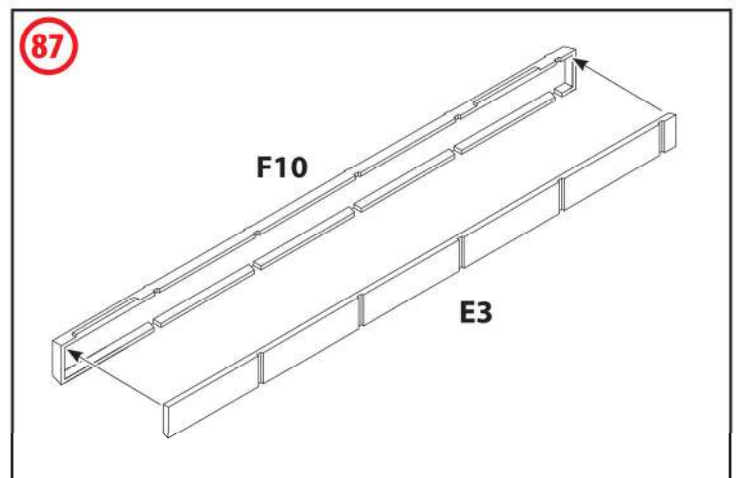
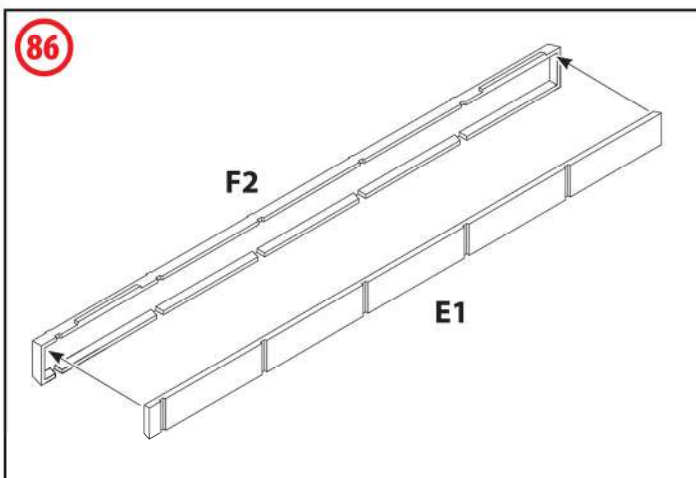
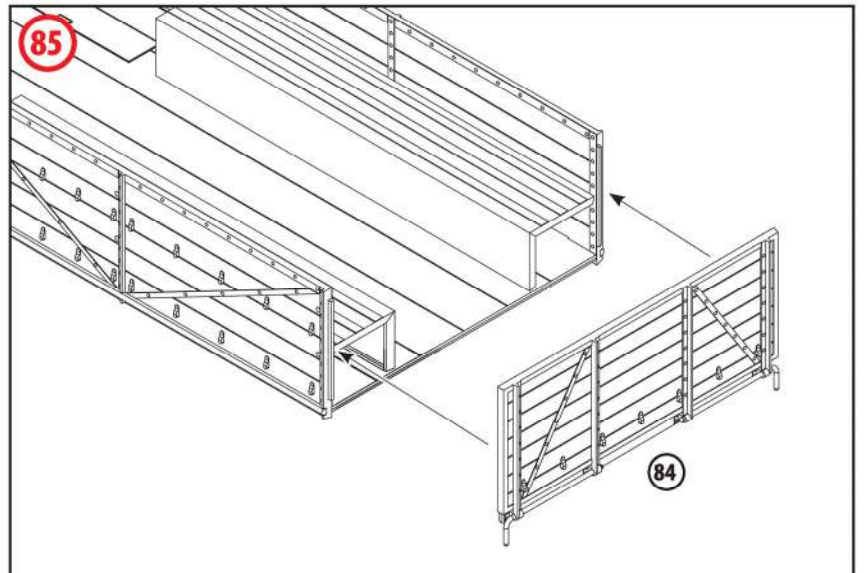
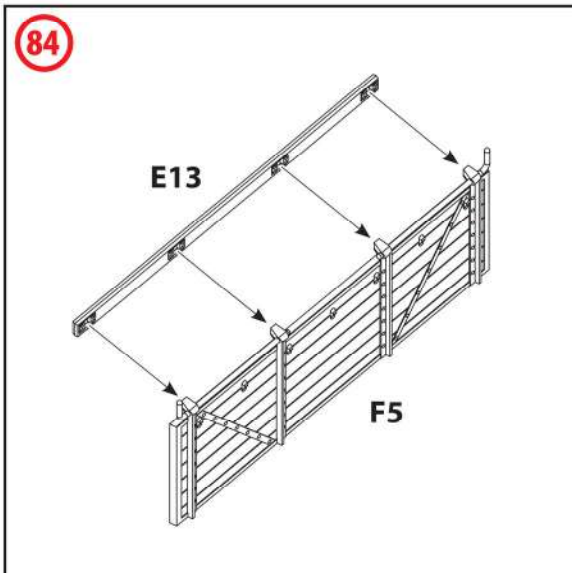
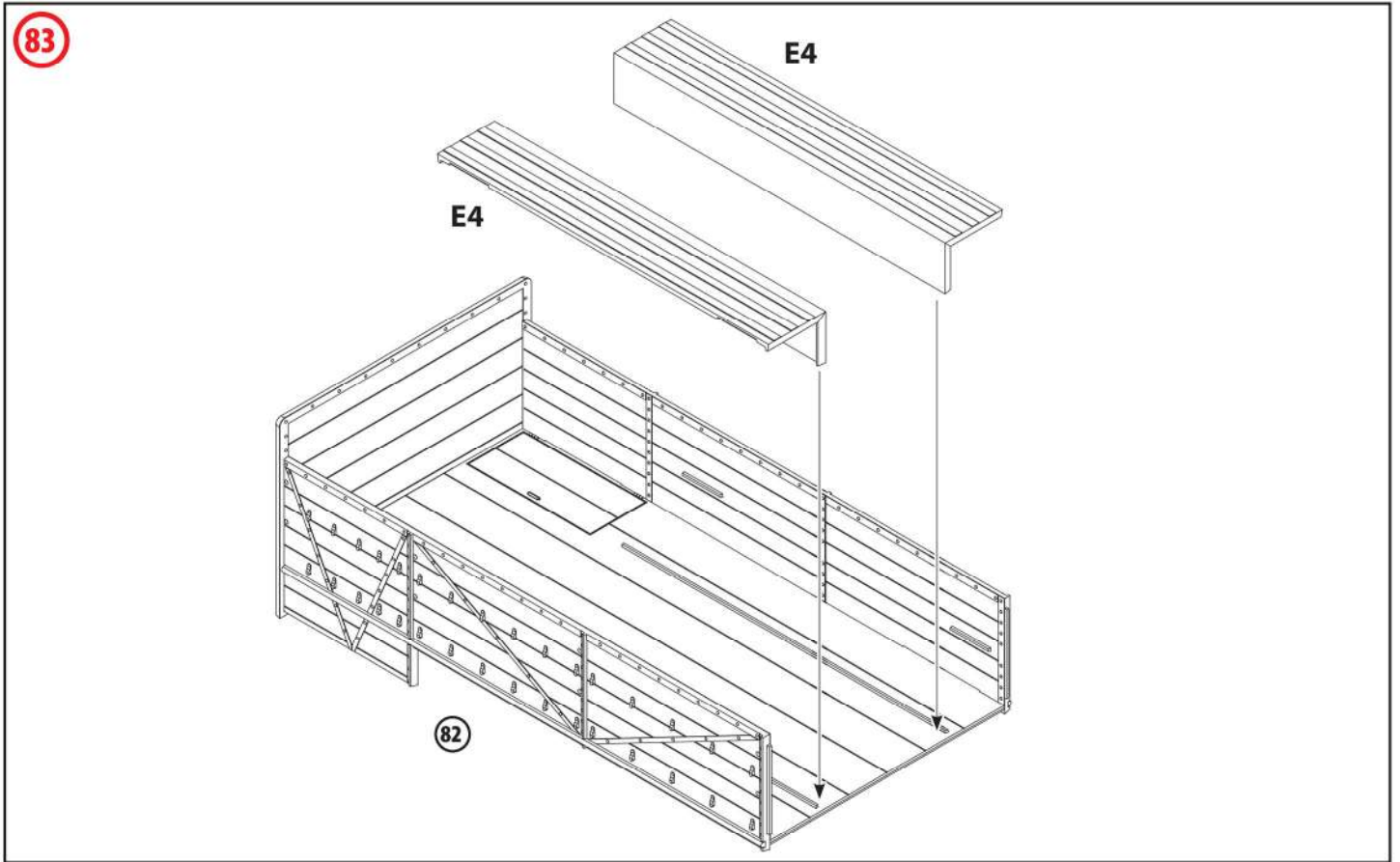

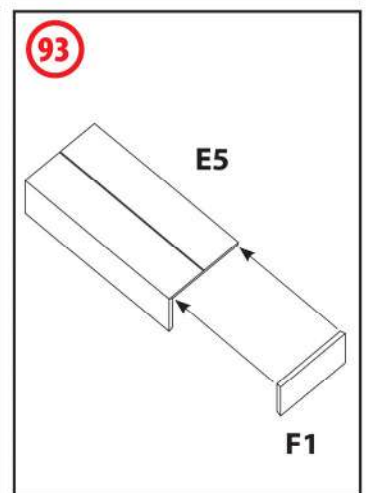
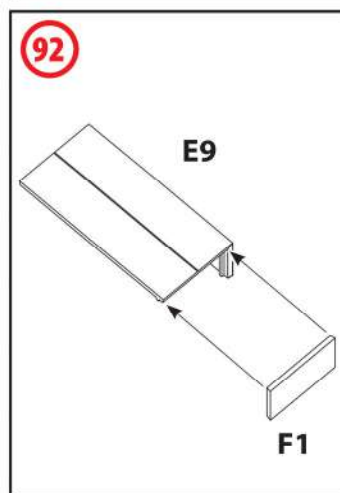
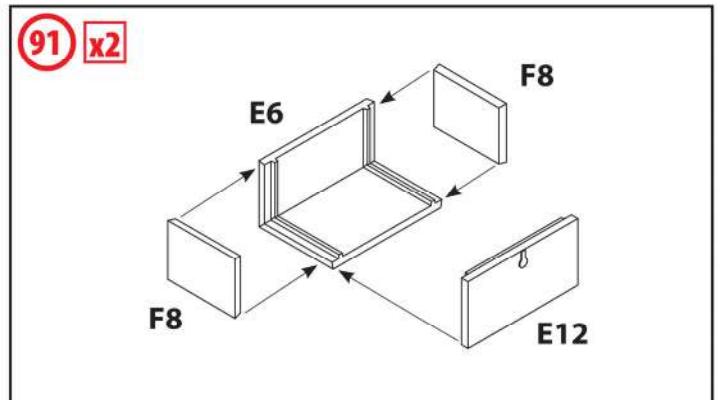
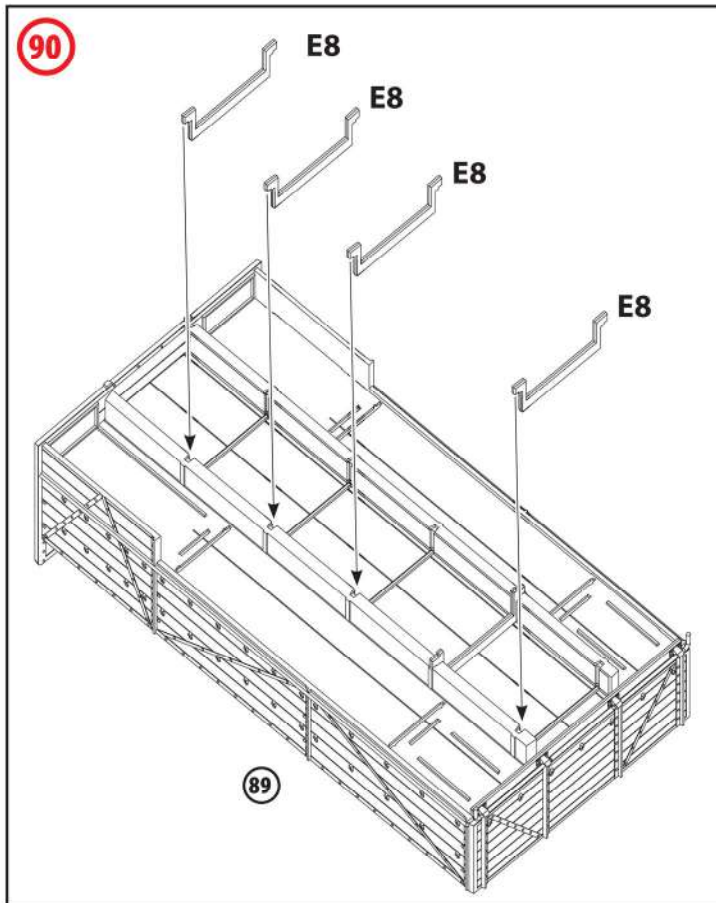
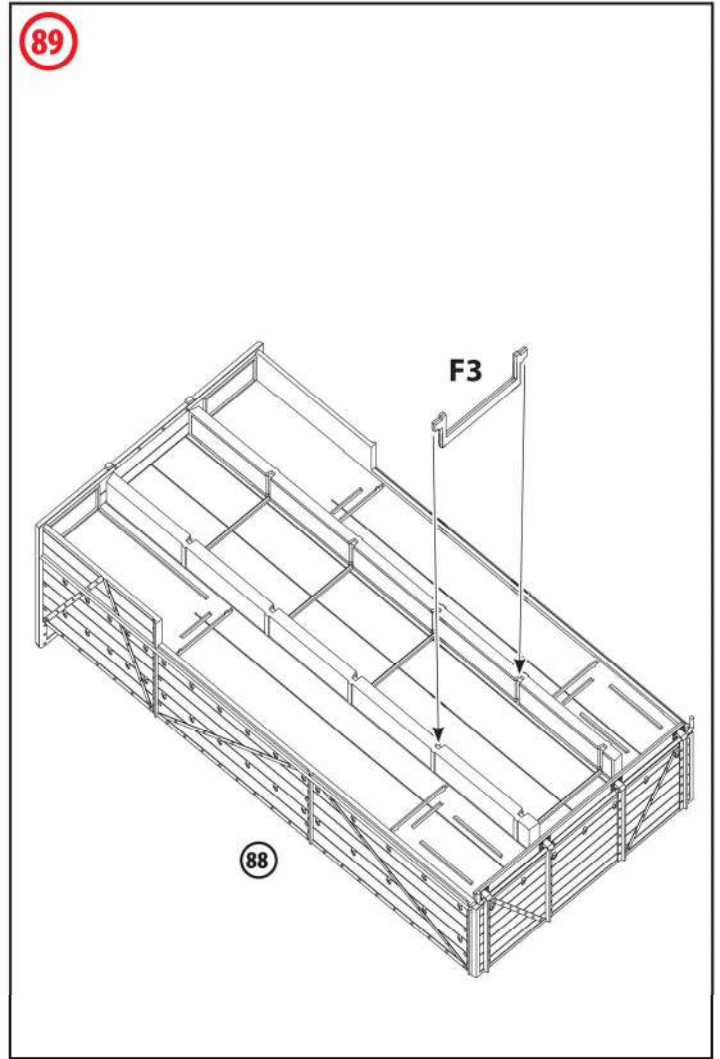
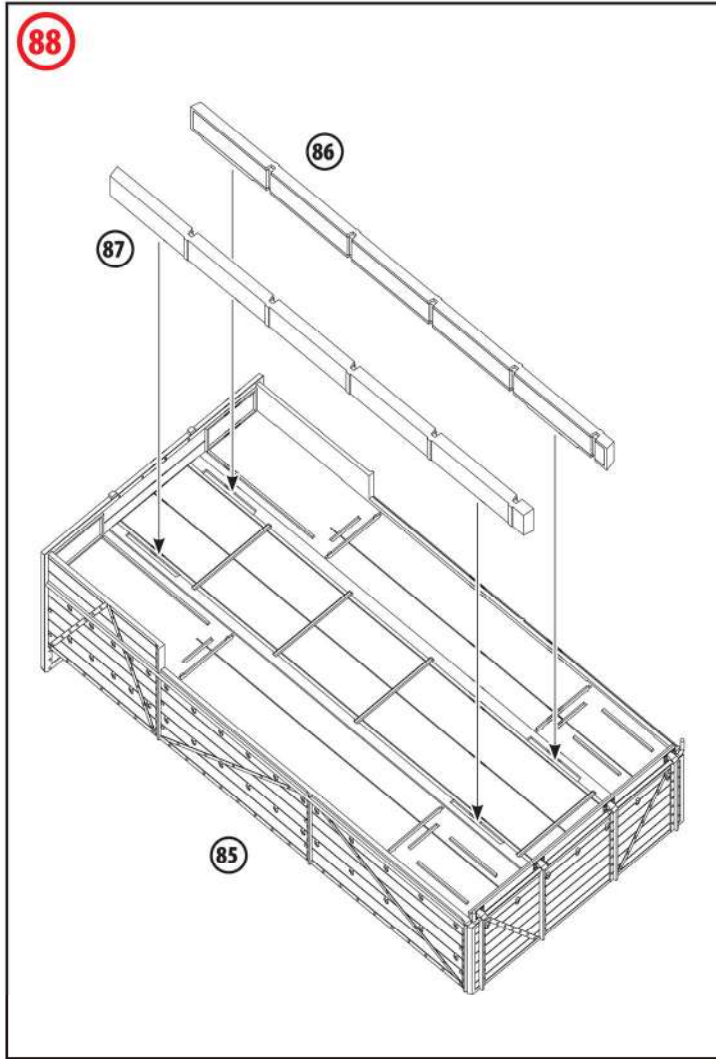

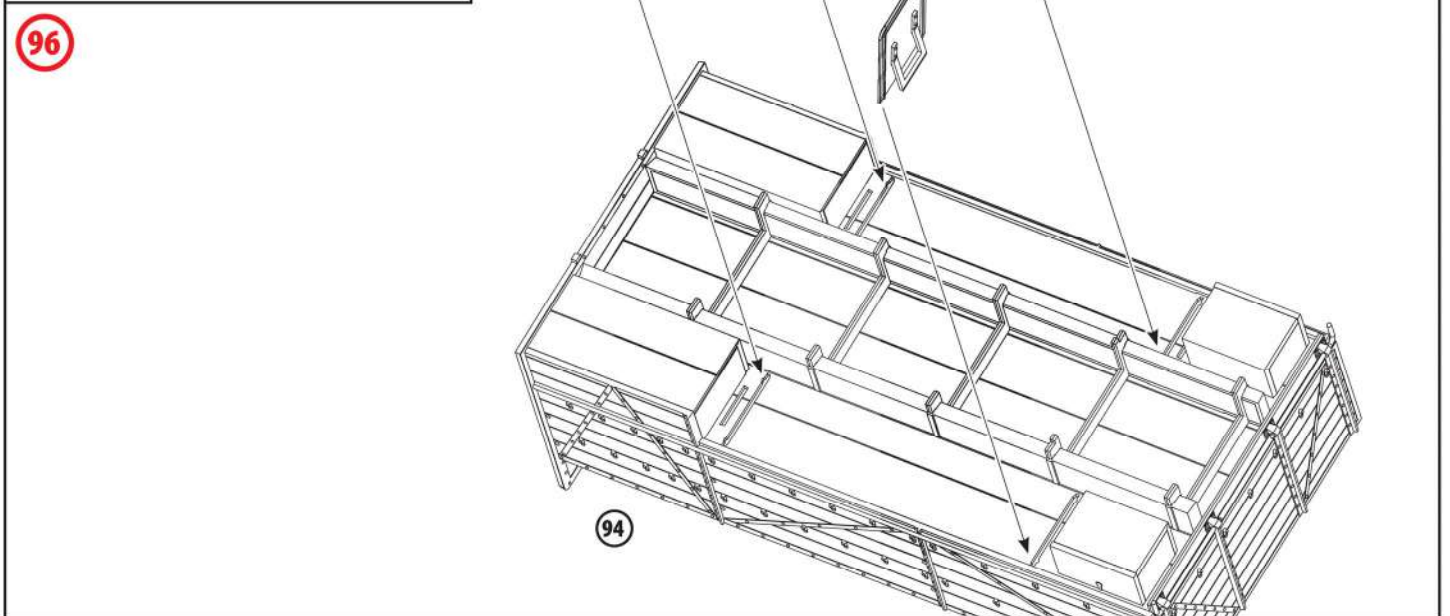
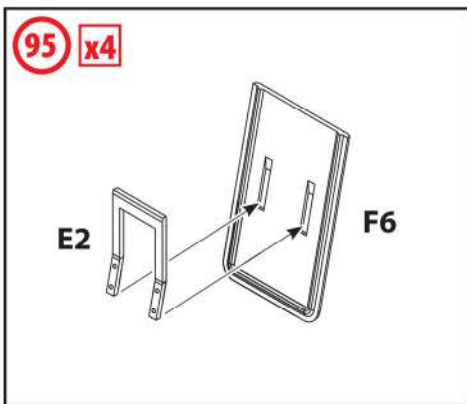
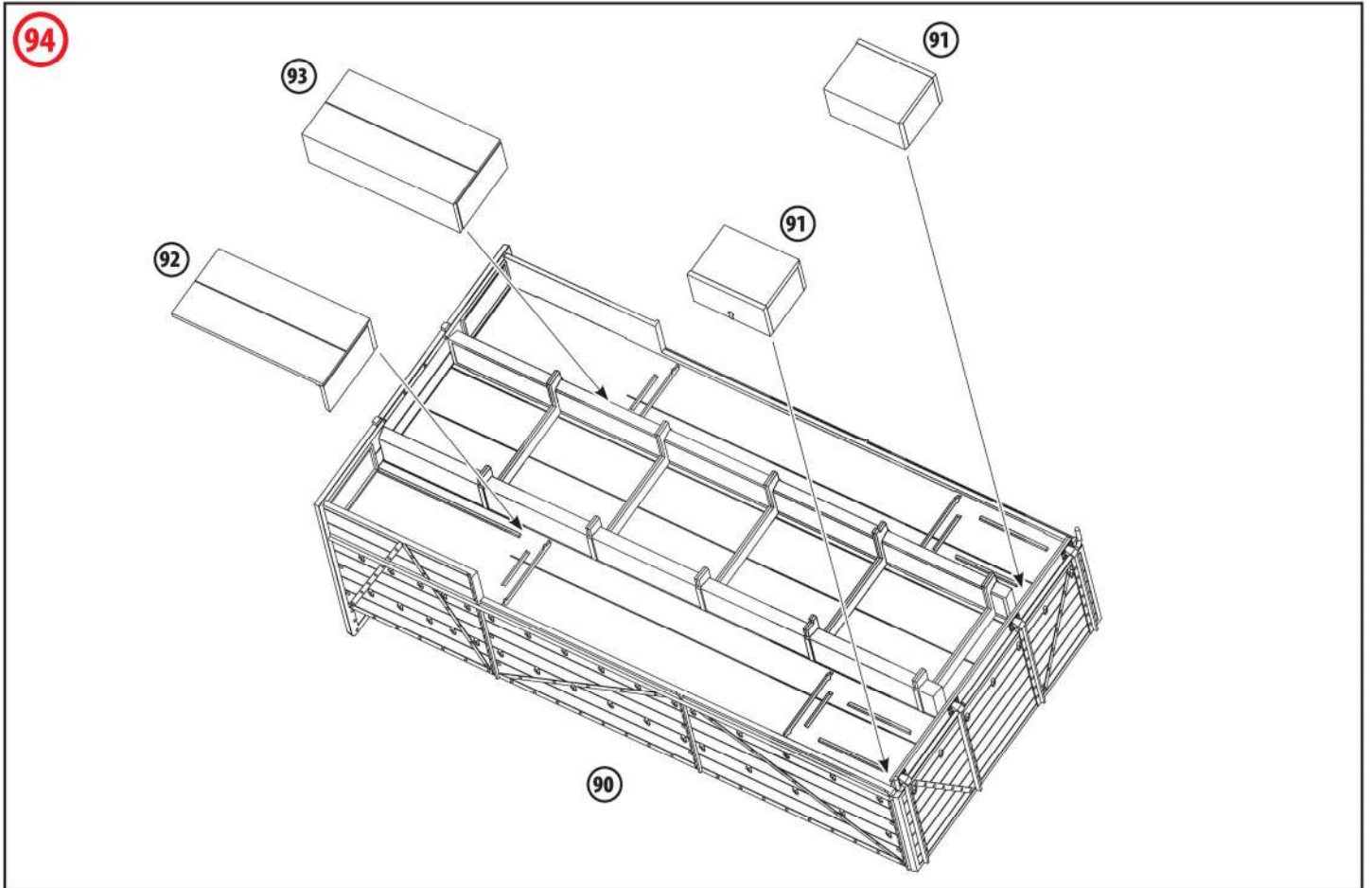

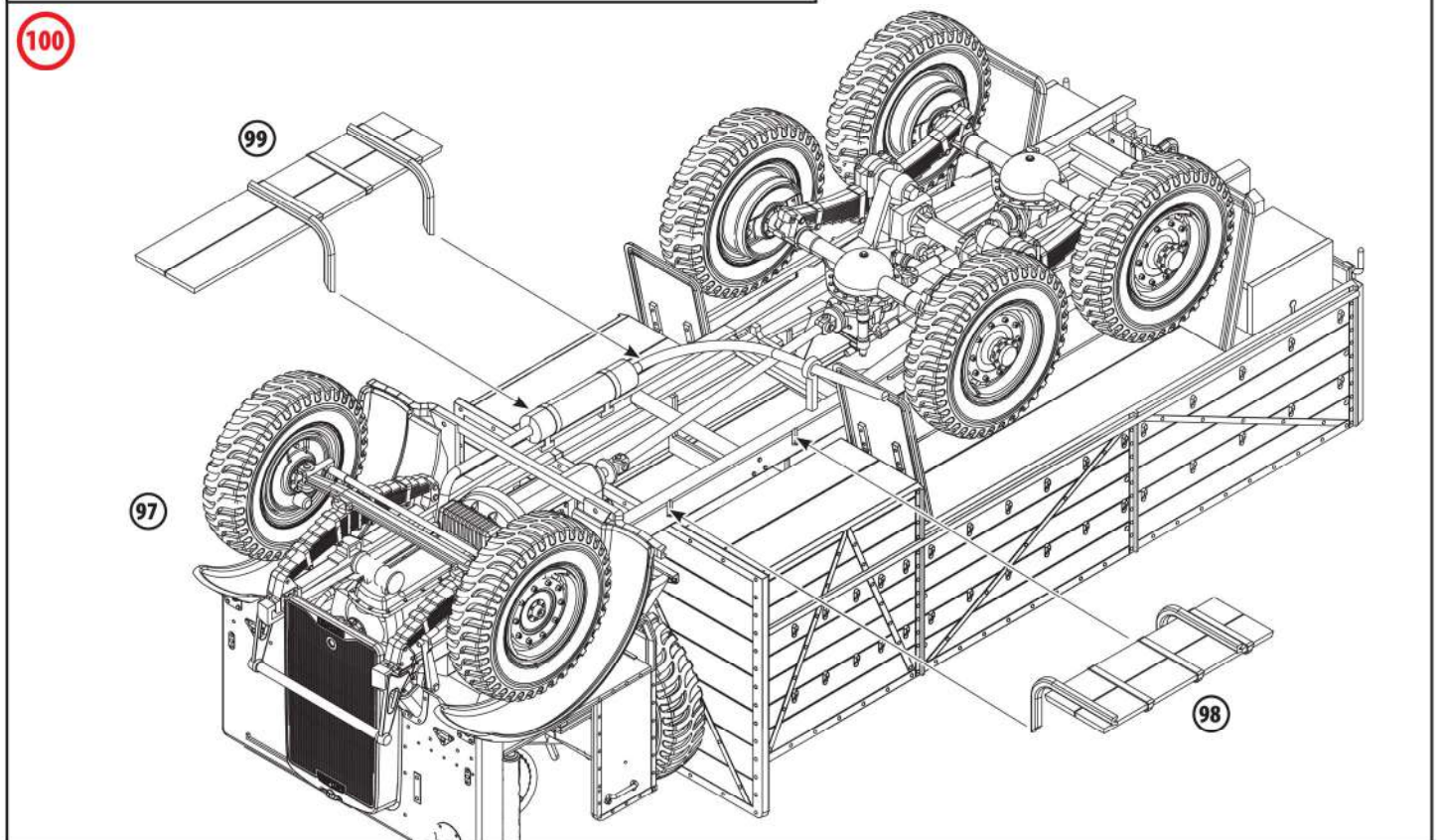
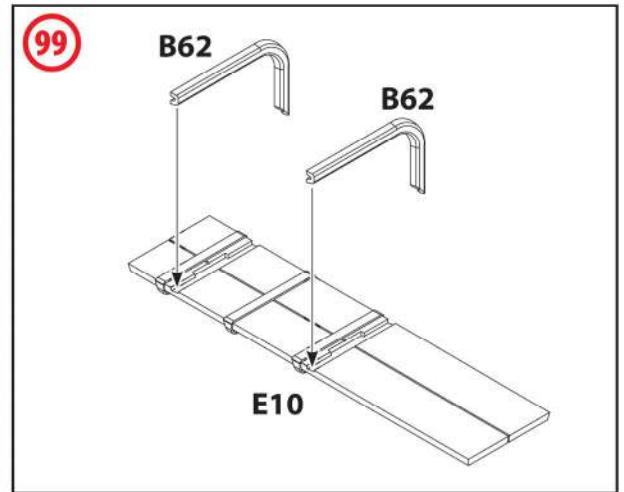
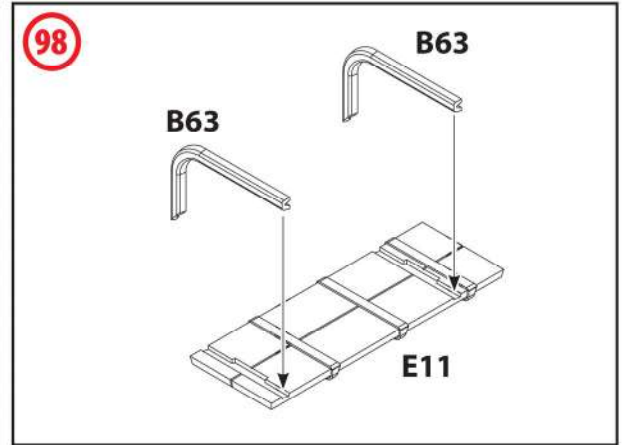
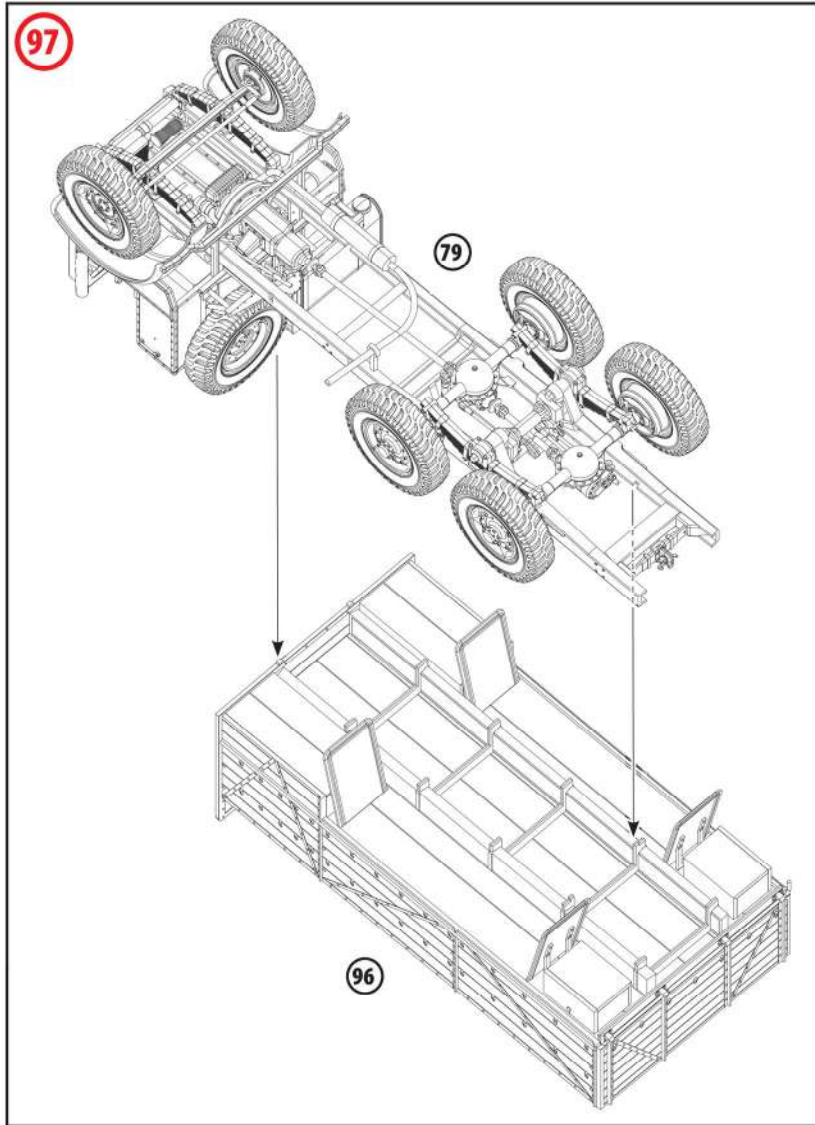

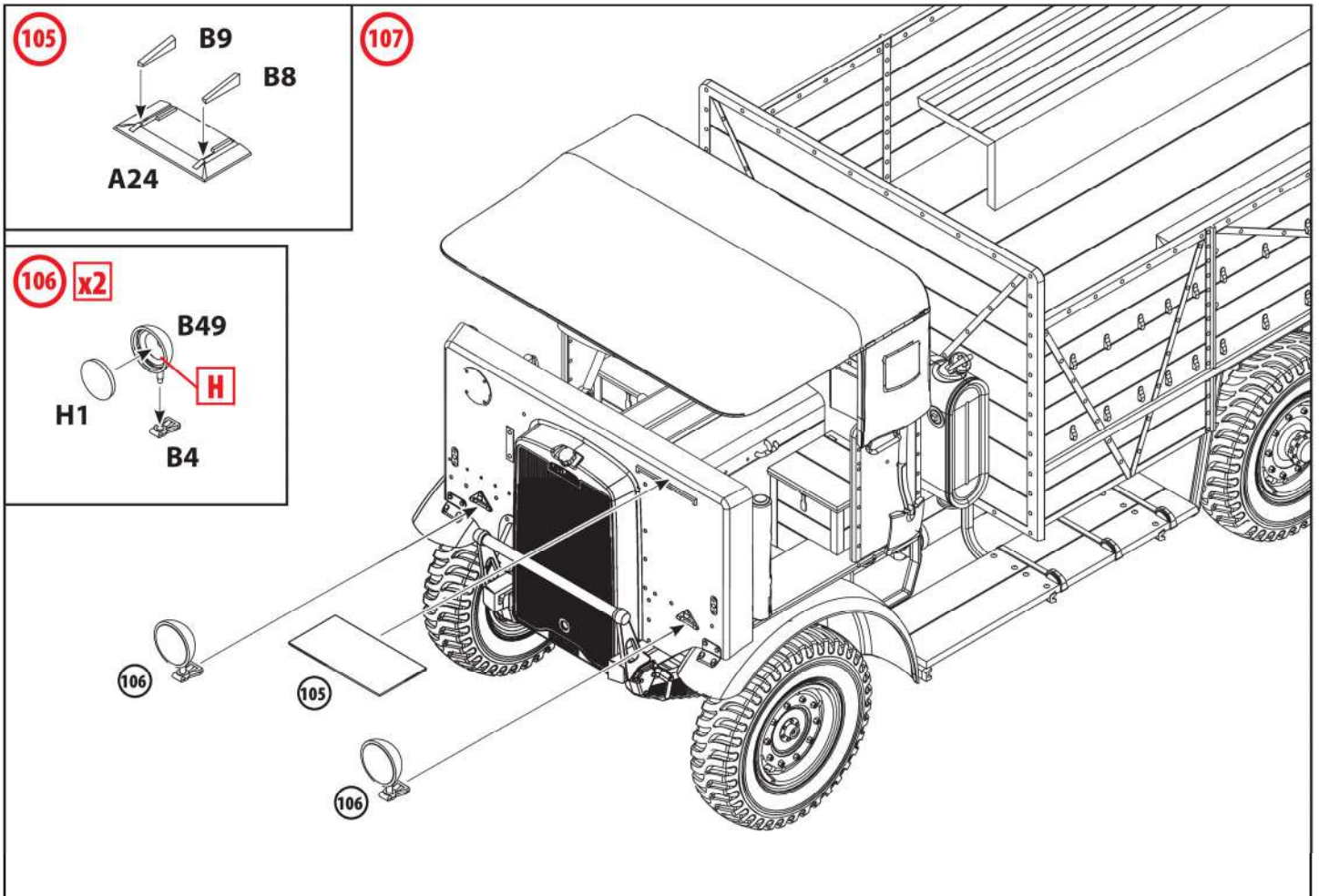
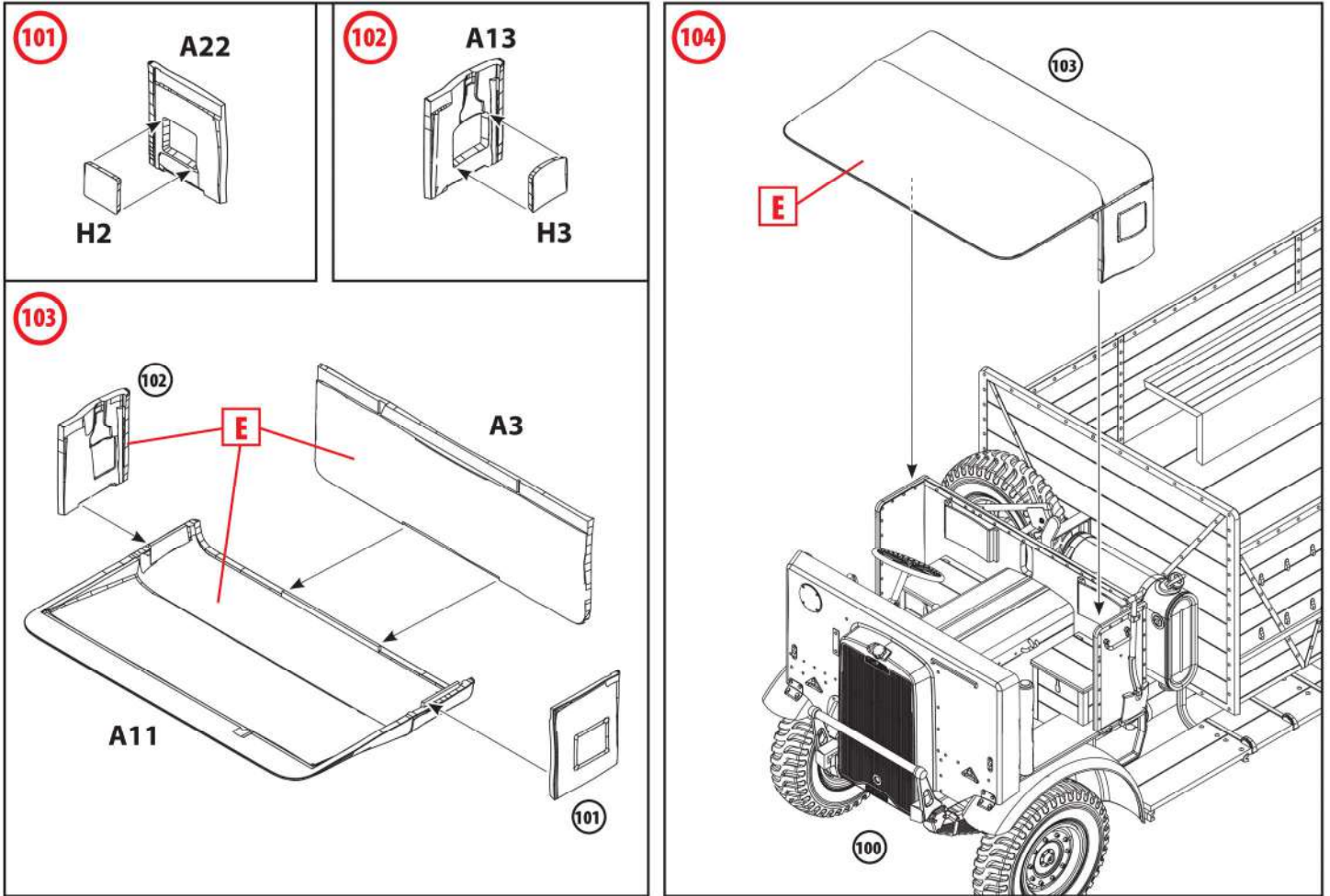

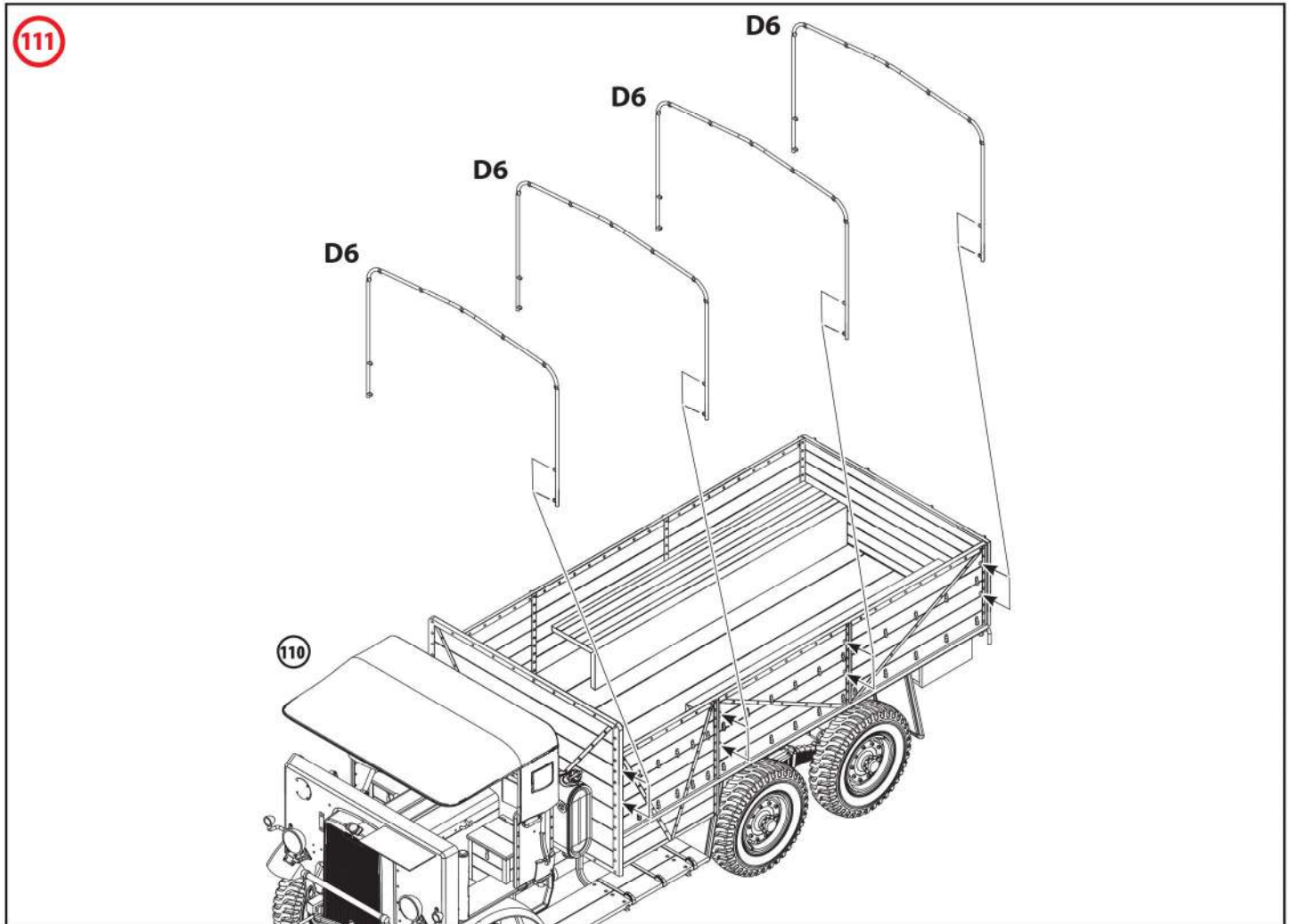
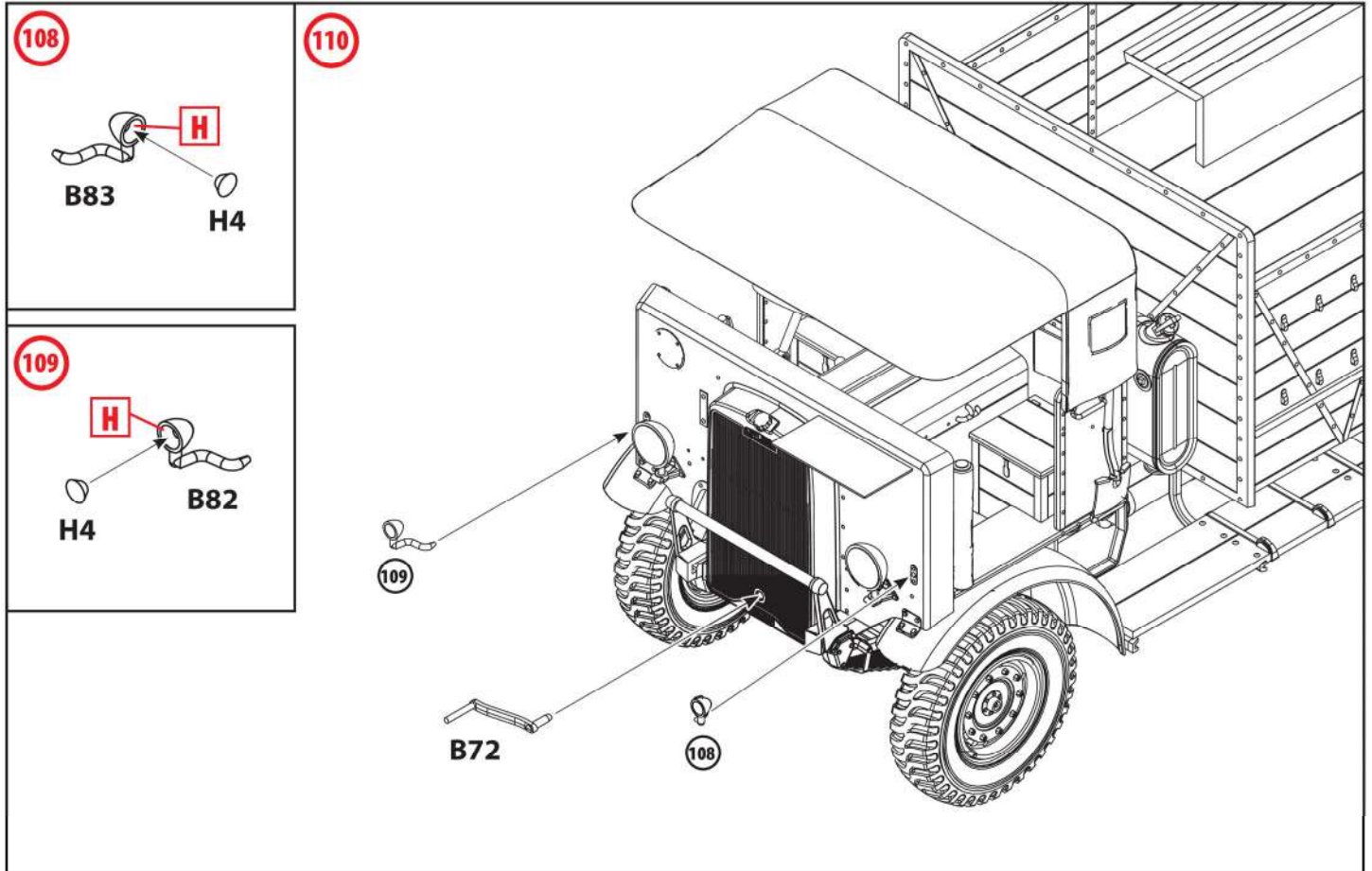

112

D2 (x7)

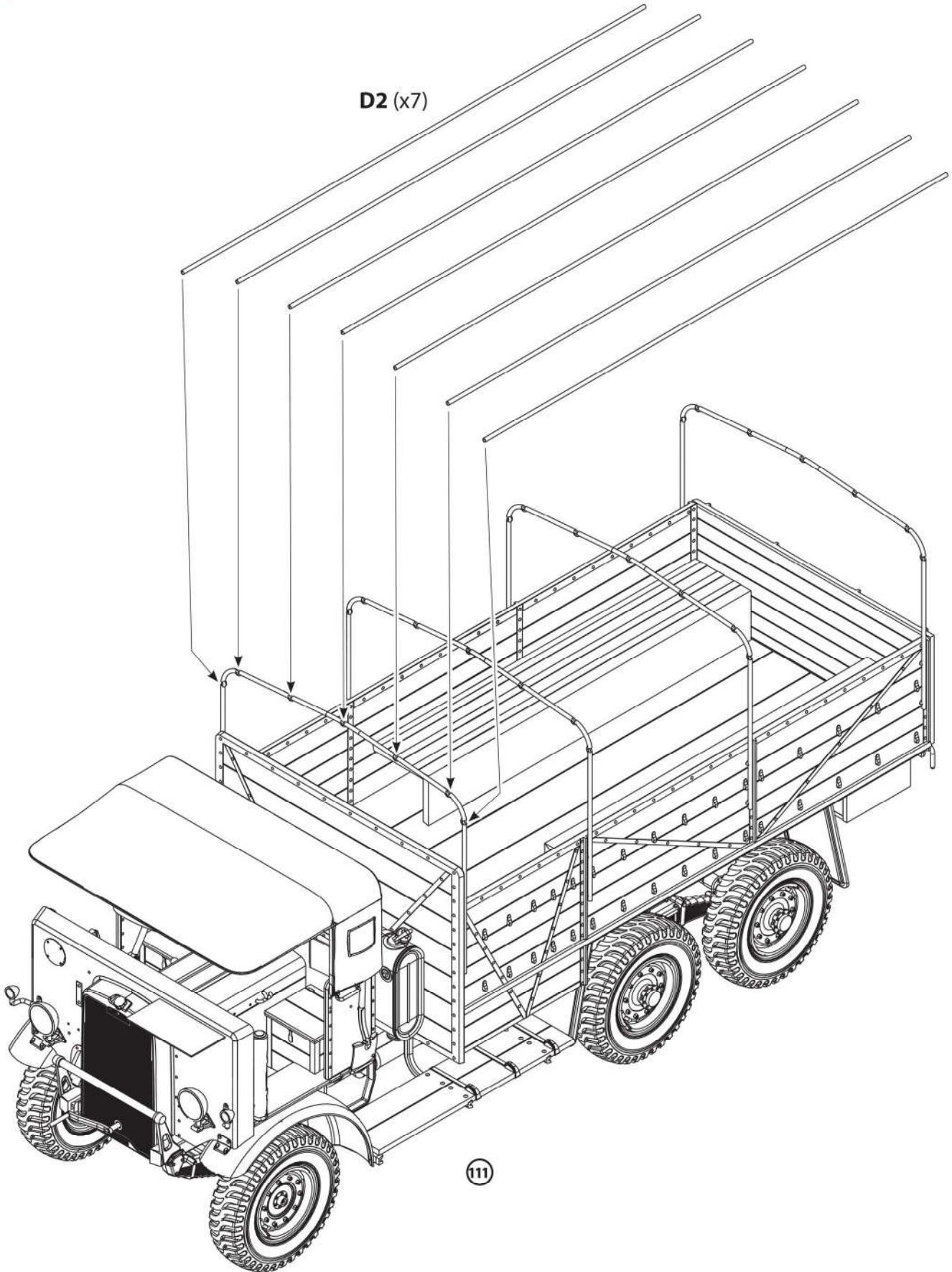

111

113

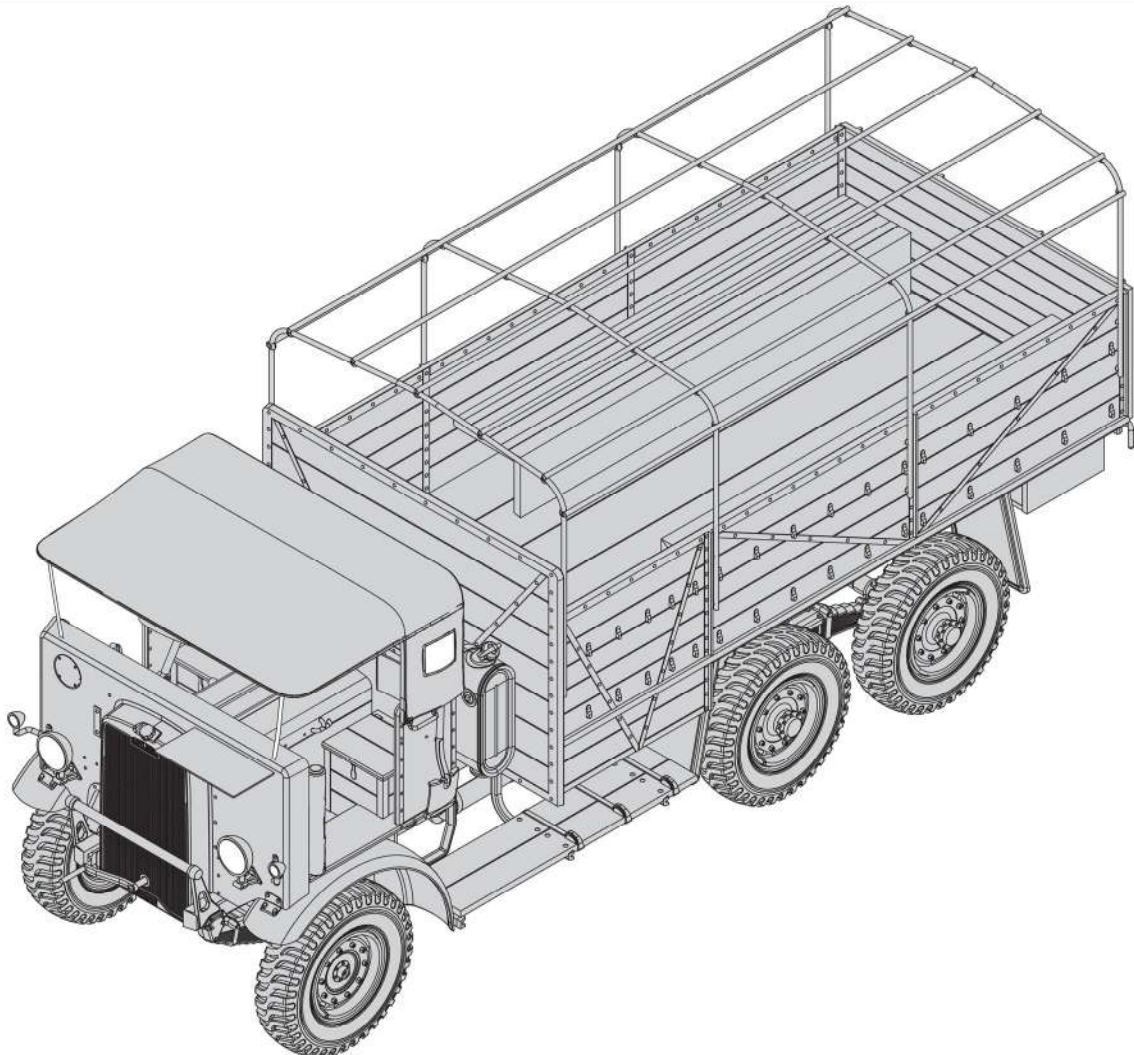
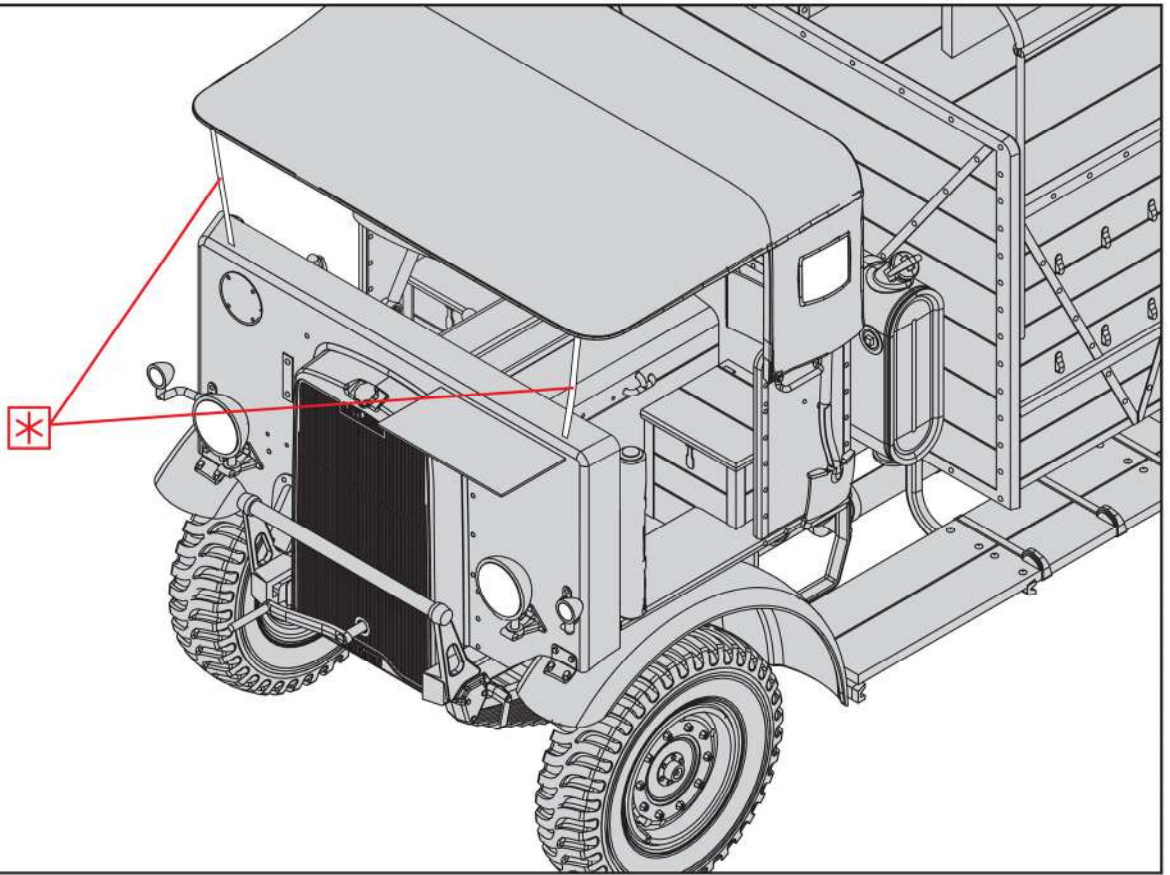

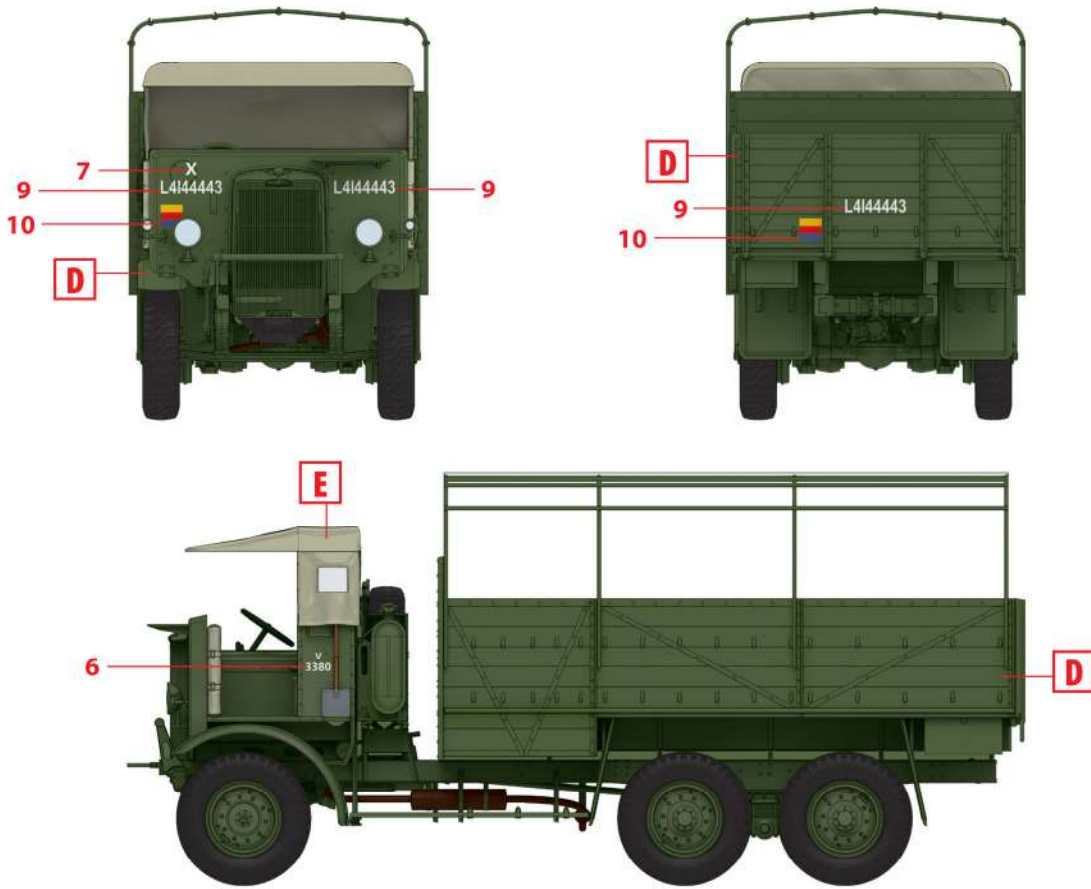

1. Leyland Retriever General Service (раннего производства) Европа 1945 г.
 Leyland Retriever General Service (early production) Europe 1945

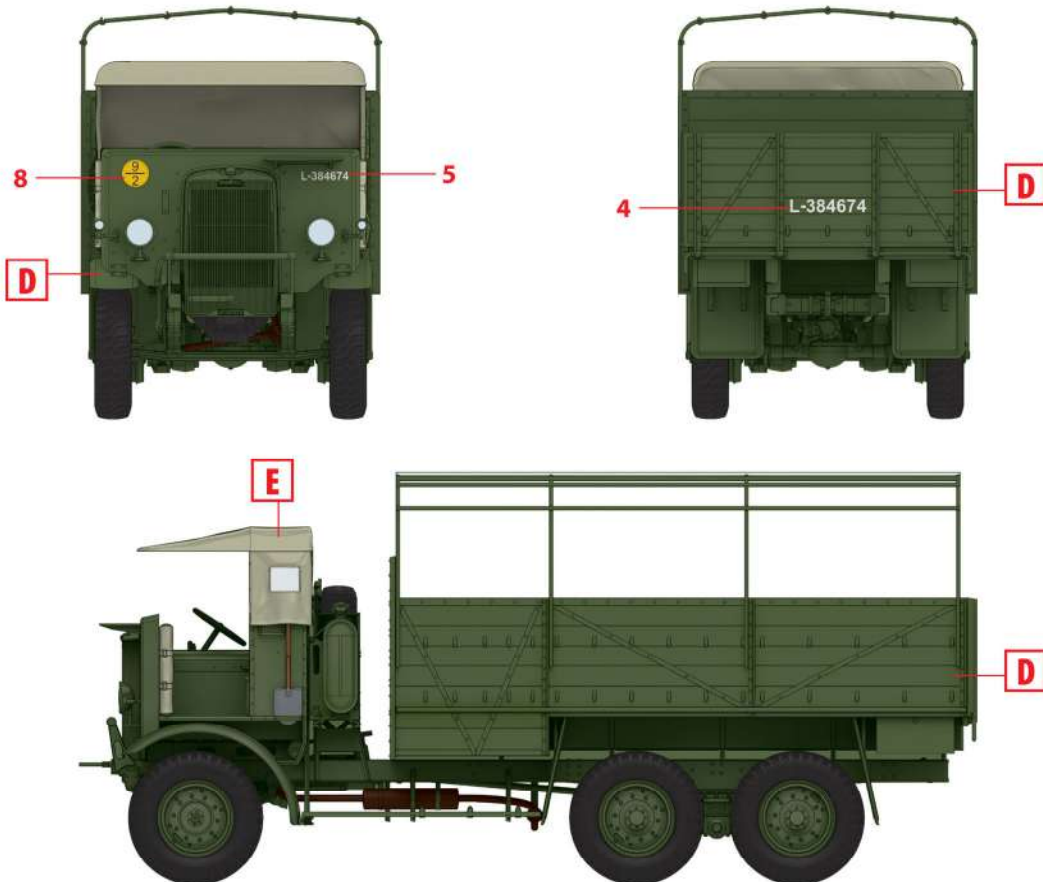

1. Leyland Retriever General Service (раннего производства) Европа 1944 г.
 Leyland Retriever General Service (early production) Europe 1944



Модель W.O.T. 6

Британский грузовой автомобиль II МВ

Одним из наиболее крупных поставщиков грузовых автомобилей для вооруженных сил Великобритании был британский филиал Форд Мотор Компани. Грузовики W.O.T. 6 4x4 строились в больших количествах (более 30000) и применялись в Северной Африке, Италии и Северо-Западной Европе между 1942 и 1945 годами. Они состояли на службе до 1962 г.

Эти грузовики строились с различными типами кузовов.

Технические характеристики автомобиля W.O.T. 6

Грузоподъемность, т	3
Длина, мм	6070
Ширина, мм	2286
Высота, мм.....	3200
База, мм	3645
Двигатель	«Форд» V8, 3,62 л, 85 л.с.
Максимальная скорость, км/ч	75

ВНИМАНИЕ!

Перед сборкой внимательно прочитайте руководство по монтажу. Каждая деталь пронумерована. Соблюдать последовательность монтажа. Необходимые рабочие инструменты: нож и напильник для зачистки деталей; резиновая лента, клейкая лента и зажимы для сушки белья для прижимания склеиваемых деталей. Детали из пластика очистить в растворе мягкого моющего средства и высушить на воздухе для того, чтобы краска и переводные картинки лучше прилипали. Перед приклеиванием проверить, подходят ли детали; клей наносить экономно. Хром и краску удалить с поверхностей склеивания. Небольшие детали покрасить перед тем, как они будут удалены из рамок. Краску необходимо хорошо просушить, только после этого продолжать сборку. Каждую соответствующую переводную картинку отдельно вырезать и примерно на 20 секунд окунуть в теплую воду. На обозначенном месте картинку отделить от бумаги и прижать промокательной бумагой.

Model W.O.T. 6

WWII British Truck

One of the largest supplier of trucks to the British forces was the Ford (UK) Motor Company.

W.O.T. 6 4x4 version were built in large numbers (over 30000) and were used in North Africa, Italy and NW Europe between 1942 and 1945, remaining in service until 1962.

These trucks were produced with different types of bodies.

Technical Specifications of W.O.T. 6 truck

Full load, t.....	3
Length, mm	6070
Width, mm	2286
Height, mm.....	3200
Wheel base, mm	3645
Engine.....	Ford V8, 3,62 l, 85 hp
Max. Speed, km/h.....	75

CAUTION!

Read the instructions thoroughly prior to assembly. Each component is numbered. Adhere to specified sequence of assembly. Tools required: knife and file for removal of components from frame; rubber bond, adhesive tape and clothes pegs for clamping components together after applying adhesive. Clean plastic components in a mild detergent solution and allow to air-dry so that paint and transfers adhere better. Prior to applying adhesive, check to see whether the components fit together; apply adhesive sparingly. Remove chrome and paint from the contact surfaces. Paint small components before removing them from the frame. Allow paint to dry well, and only then continue to assemble. Cut out each transfer individually and immerse in warm water for approx. 20 seconds. Slide transfer off paper and into designated position, then press on with blotting paper.

ИСПОЛЬЗУЕМЫЕ КРАСКИ / USED COLORS:

	Revell	Tamiya		
A	105	XF2	Белый, матовый	Flat White
B	107	X1	Черный, глянцевый	Gloss Black
C	302	X18	Черный, полуматовый	Semigloss Black
D	165	XF58	Оливково-зеленый, мат.	Olive Green
E	186	XF49	Хаки, матовый	Khaki
F	189	XF78	Дерево	Wood

	Revell	Tamiya		
G	191	X32	Сталь	Steel
H	190	X11	Серебристый	Chrome Silver
J	731	X27	Красный, прозрачный	Clear Red
K	183	XF84	Ржавчина	Rust
L	179	XF25	Серо-голубой, матовый	Intermediate Blue

01 СТАДИЯ СБОРКИ
ASSEMBLY STEP

03 СБОРОЧНАЯ ЕДИНИЦА
ASSEMBLY UNIT

? ПРОИЗВОЛЬНЫЙ ВЫБОР
OPTIONAL

↘ СОГНУТЬ
BEND

□ ПРОСВЕРЛИТЬ
OPEN HOLE

x2 СДЕЛАТЬ ДВЕ ДЕТАЛИ
MAKE 2 PCS

A ИСПОЛЬЗУЕМАЯ КРАСКА
USED COLOR

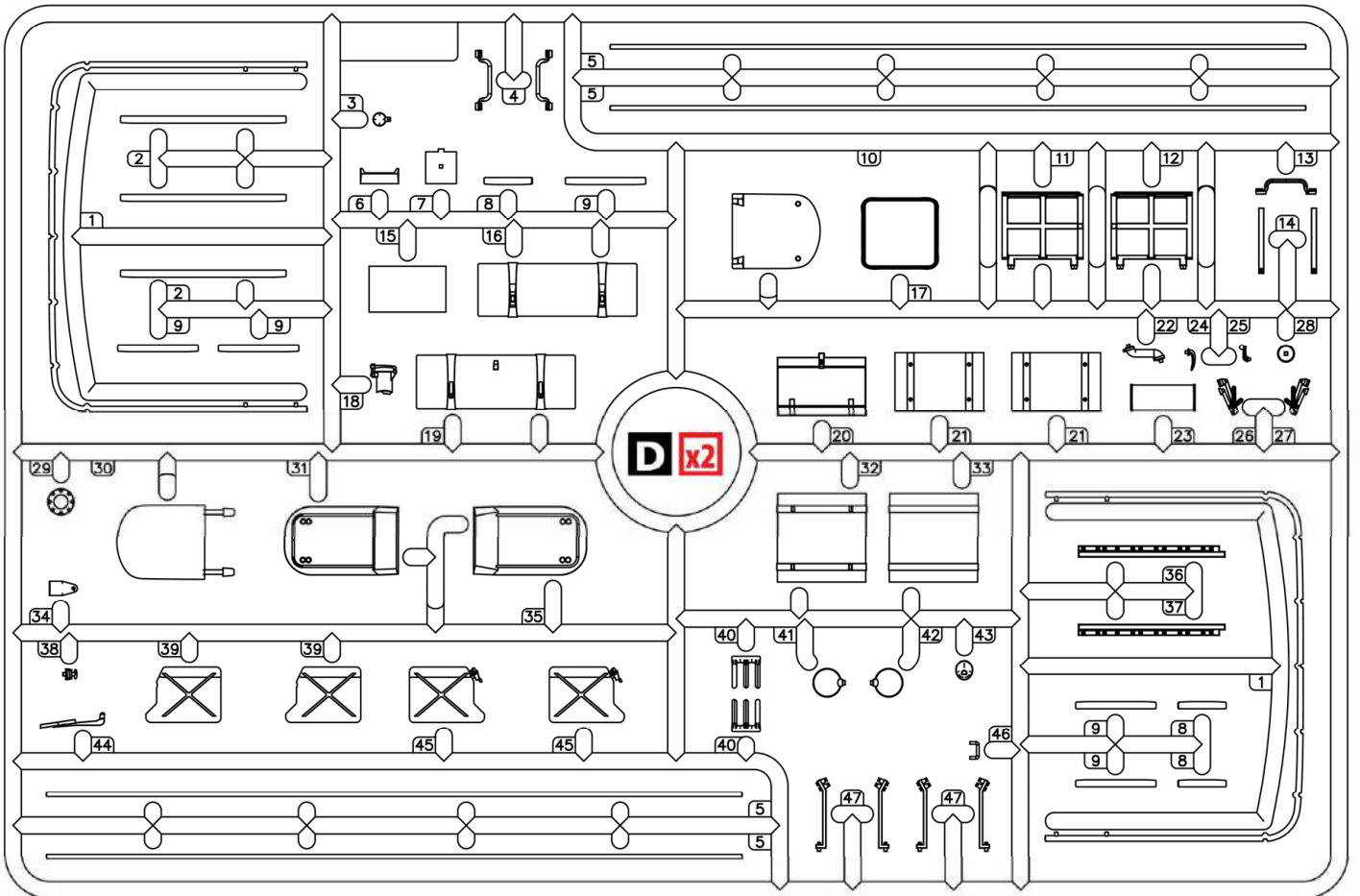
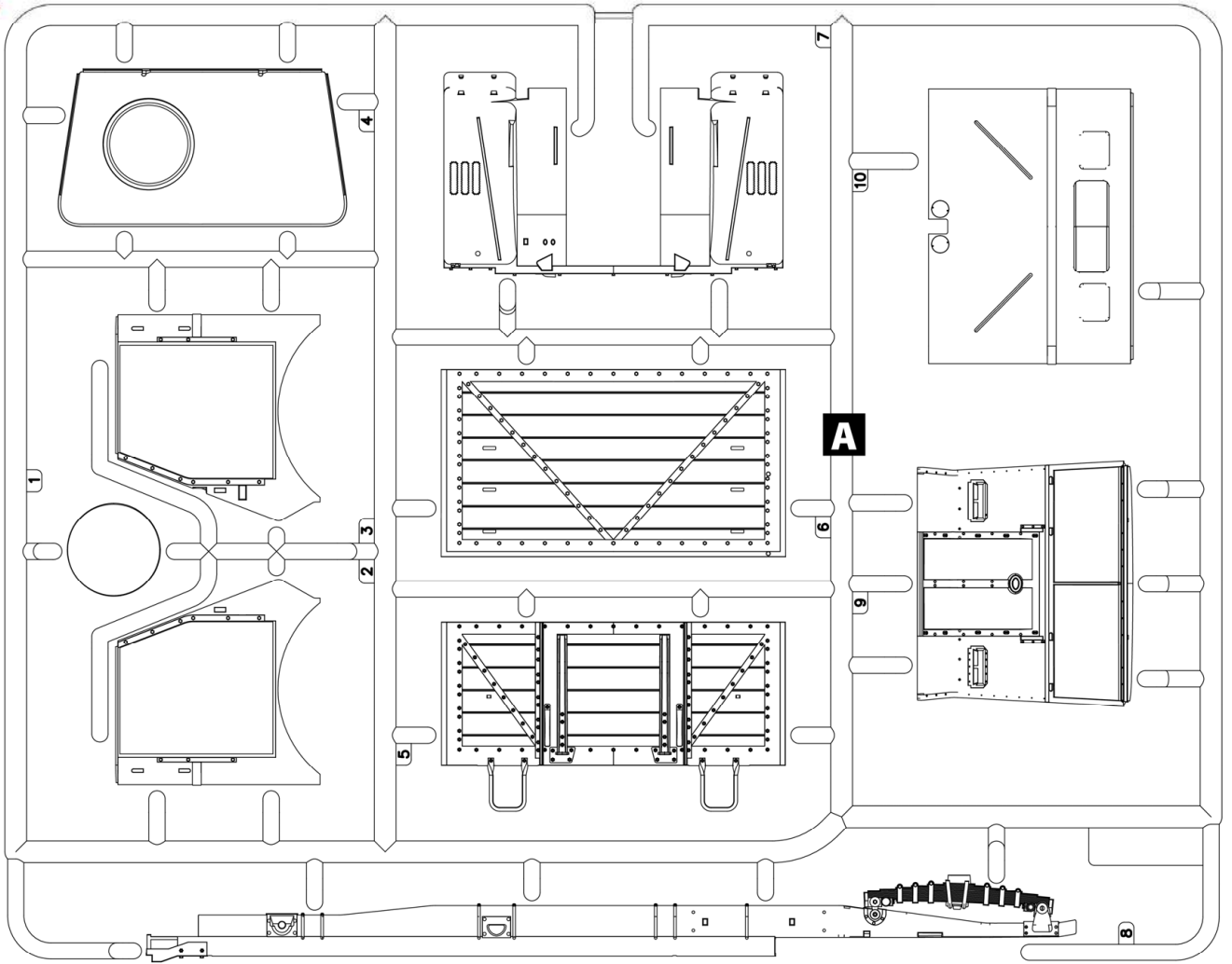

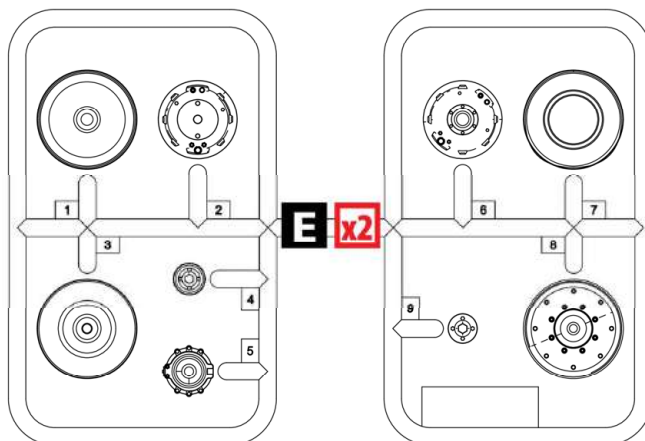
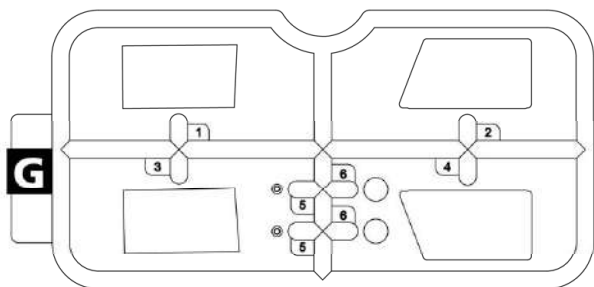
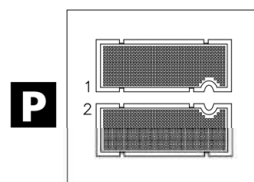
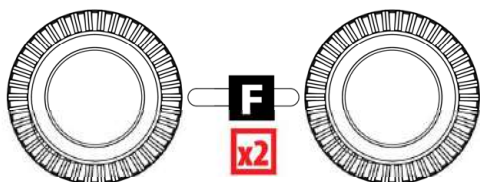
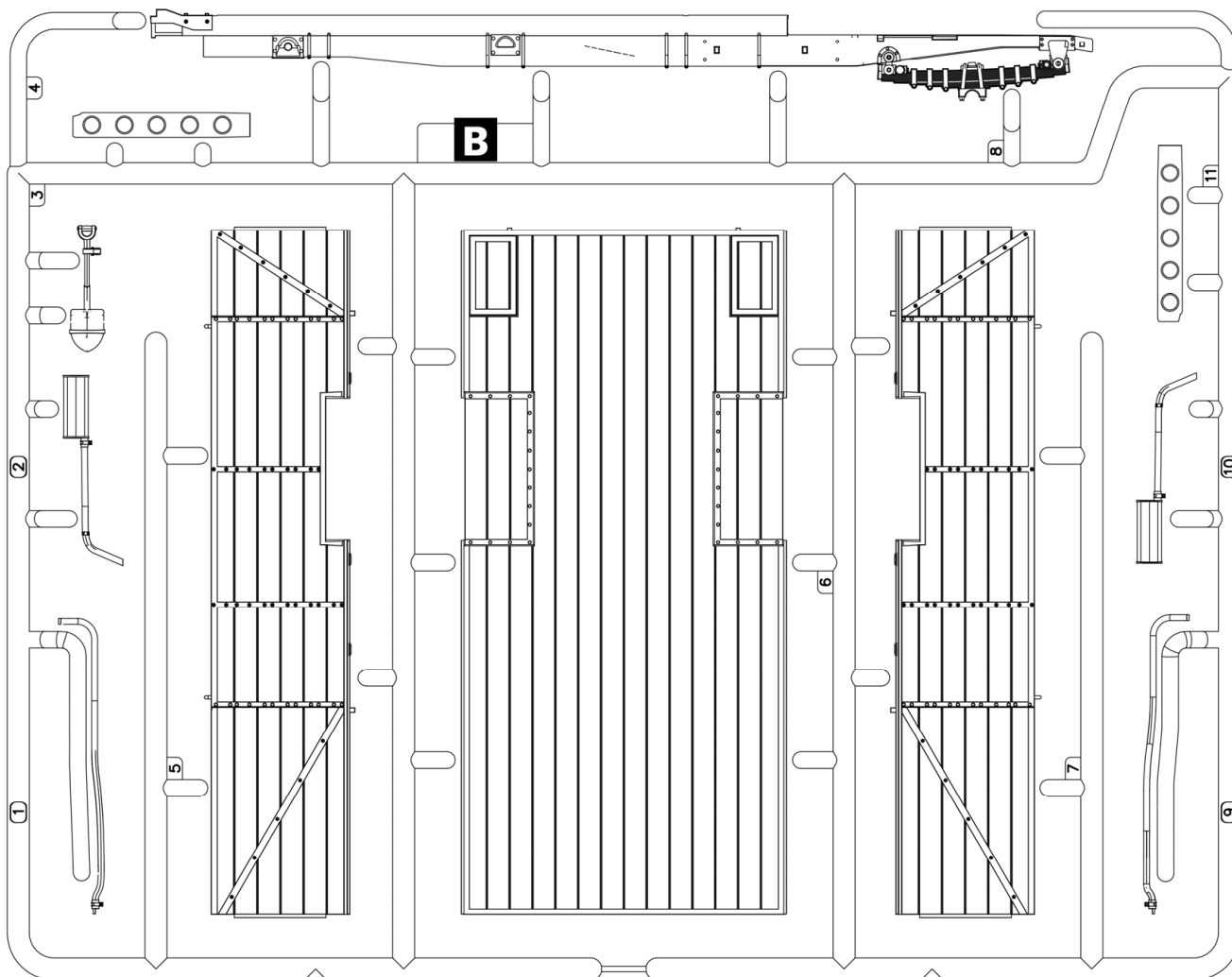

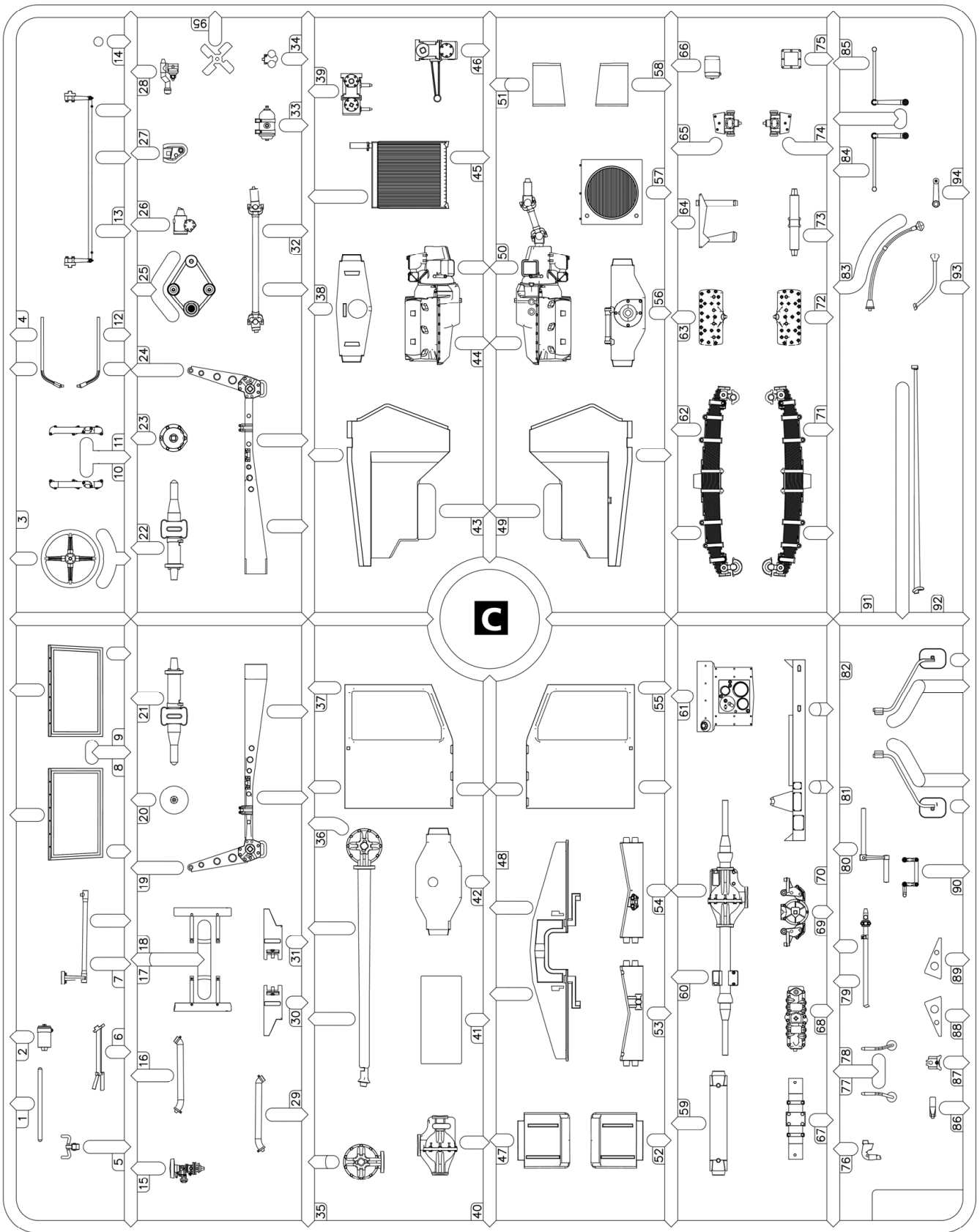

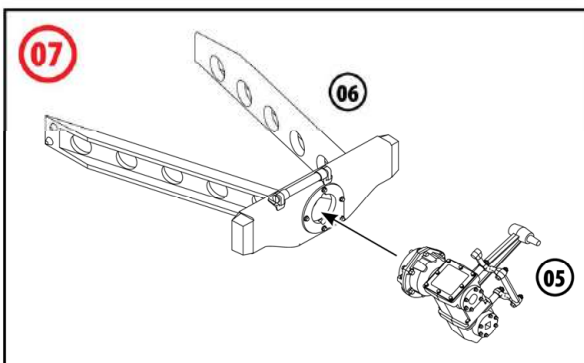
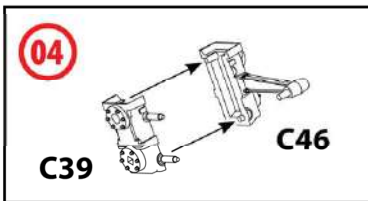
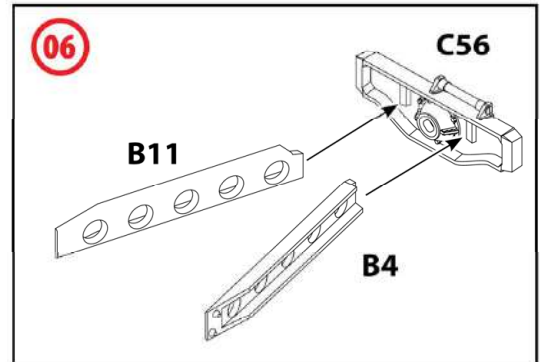
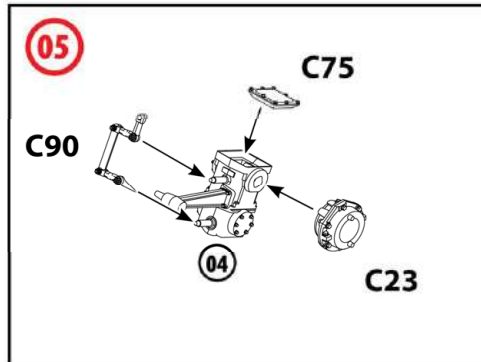
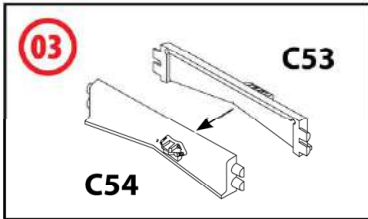
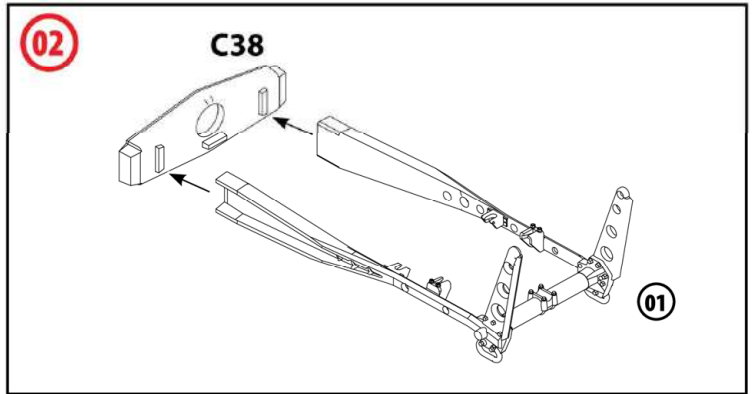
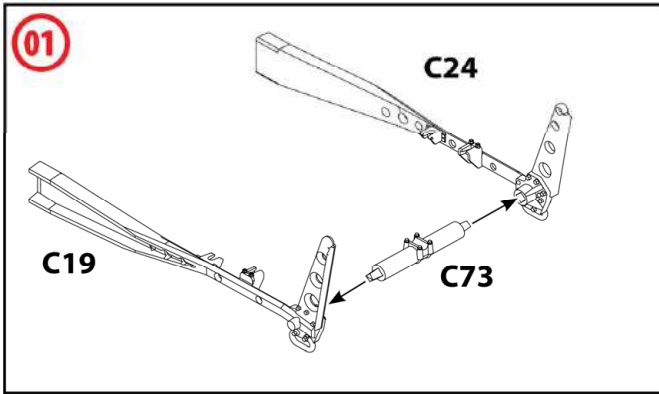

D ВСЕ ДЕТАЛИ ШАССИ, КРОМЕ ОБОЗНАЧЕННЫХ ОТДЕЛЬНО
ALL CHASSIS DETAILS EXCEPT MARKED SEPARATLY

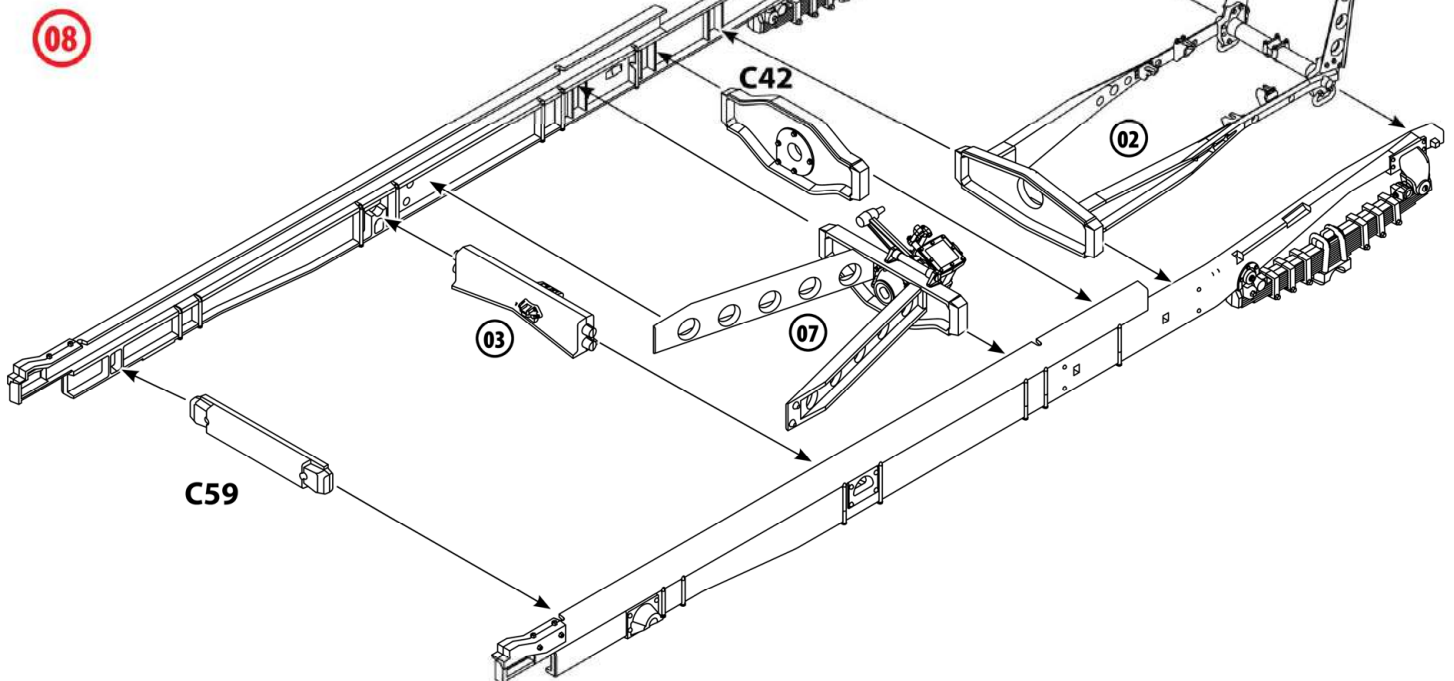

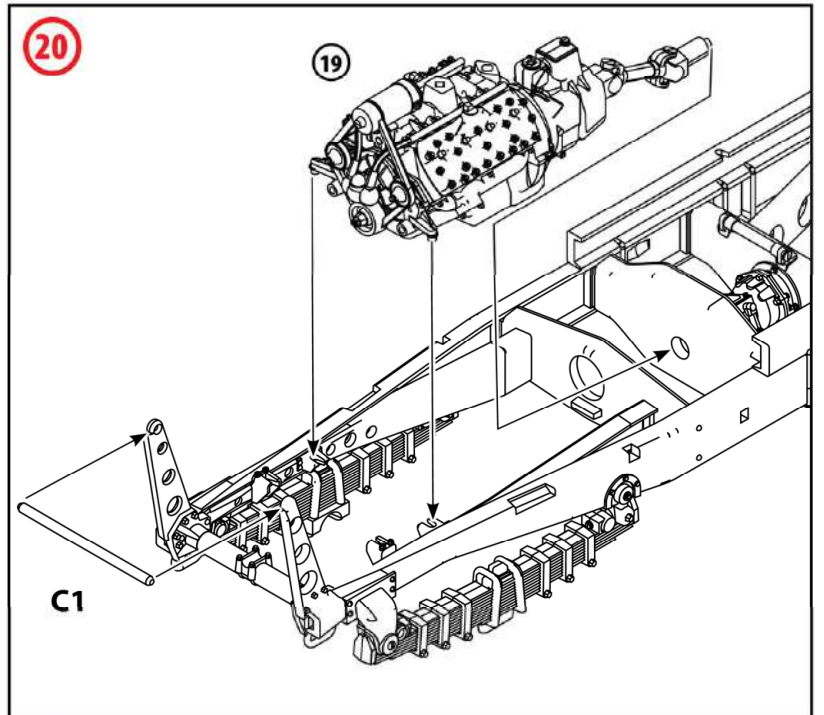
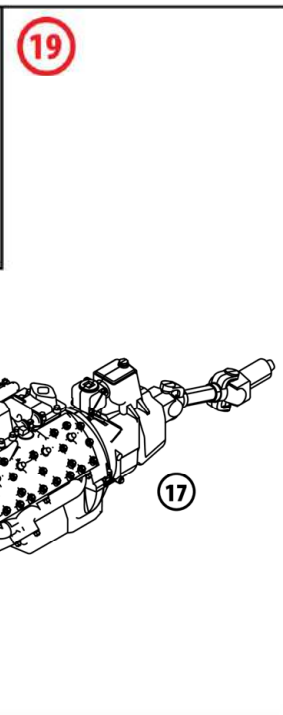
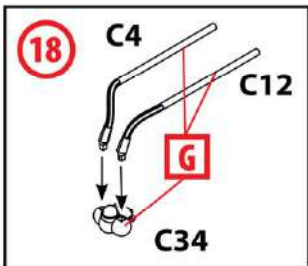
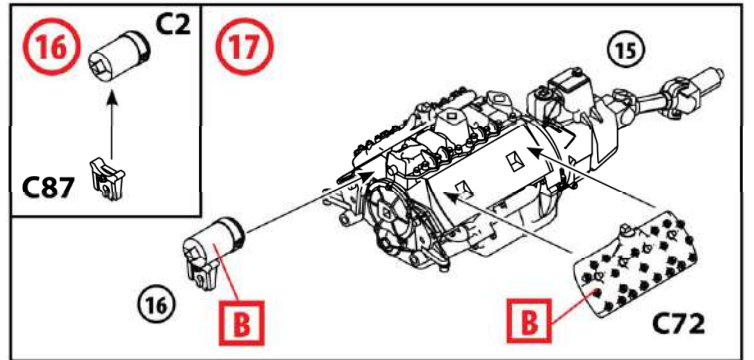
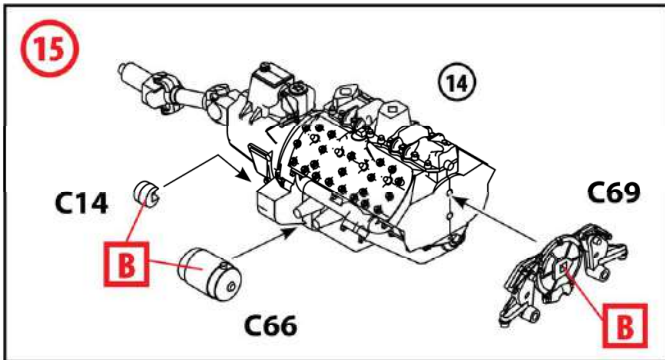
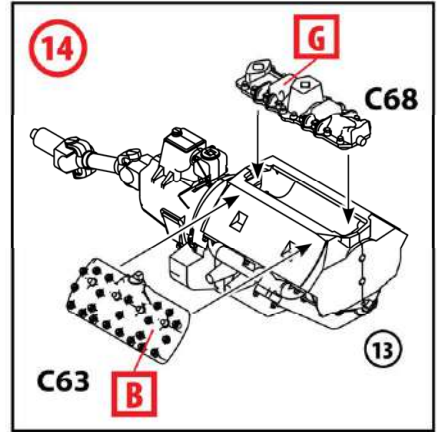
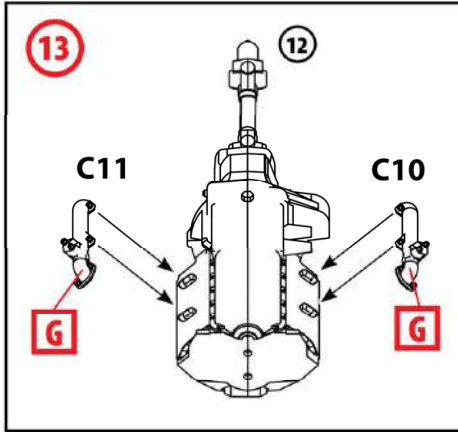
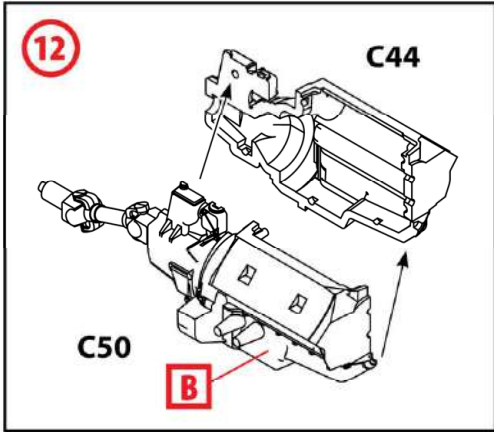
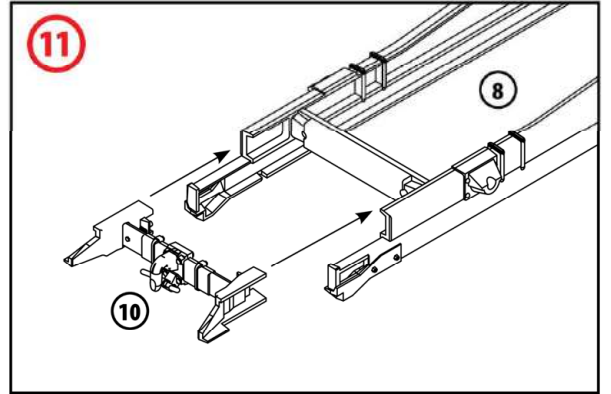
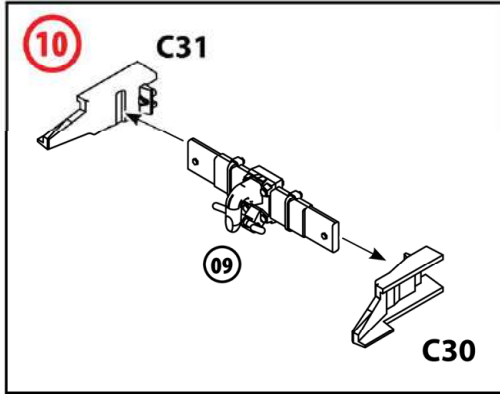
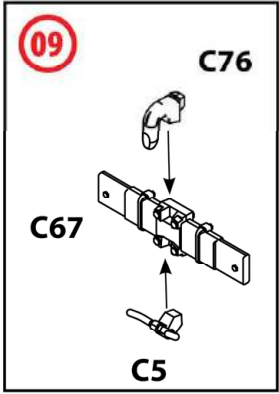

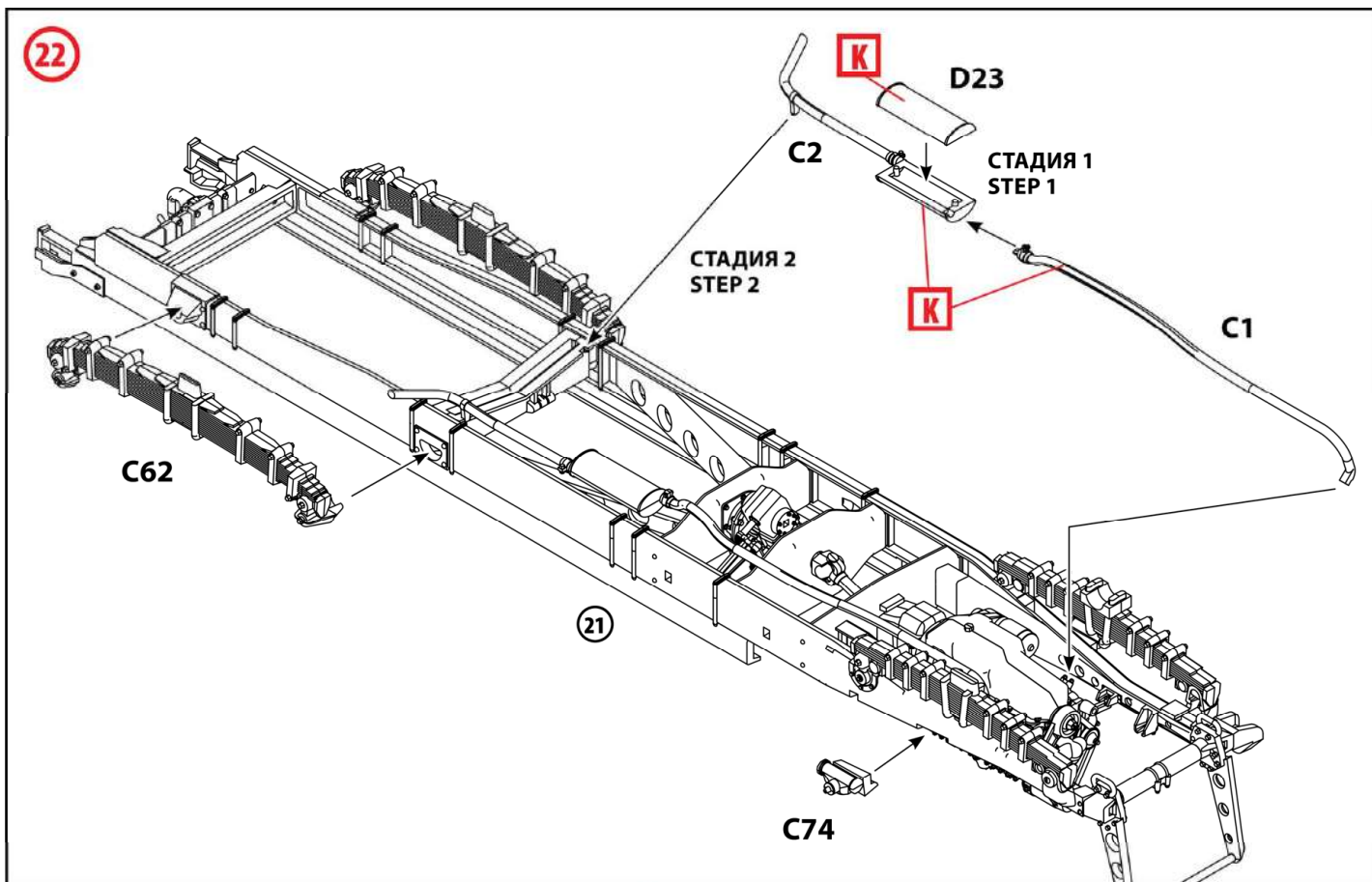
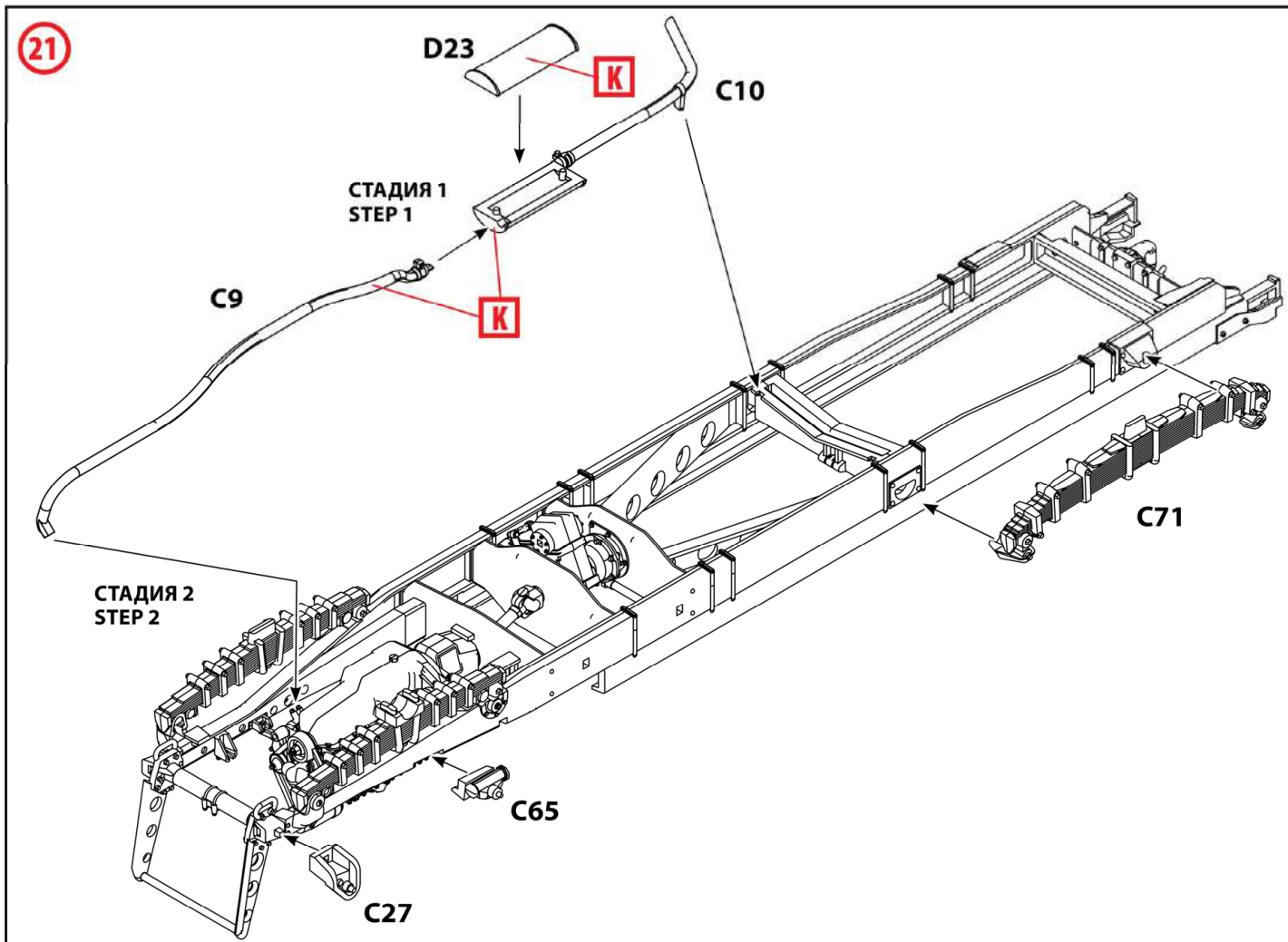

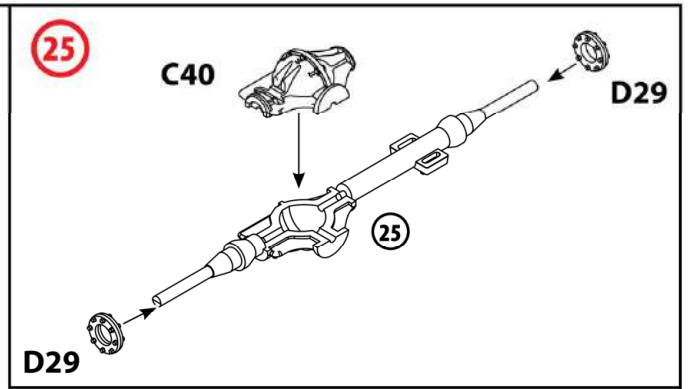
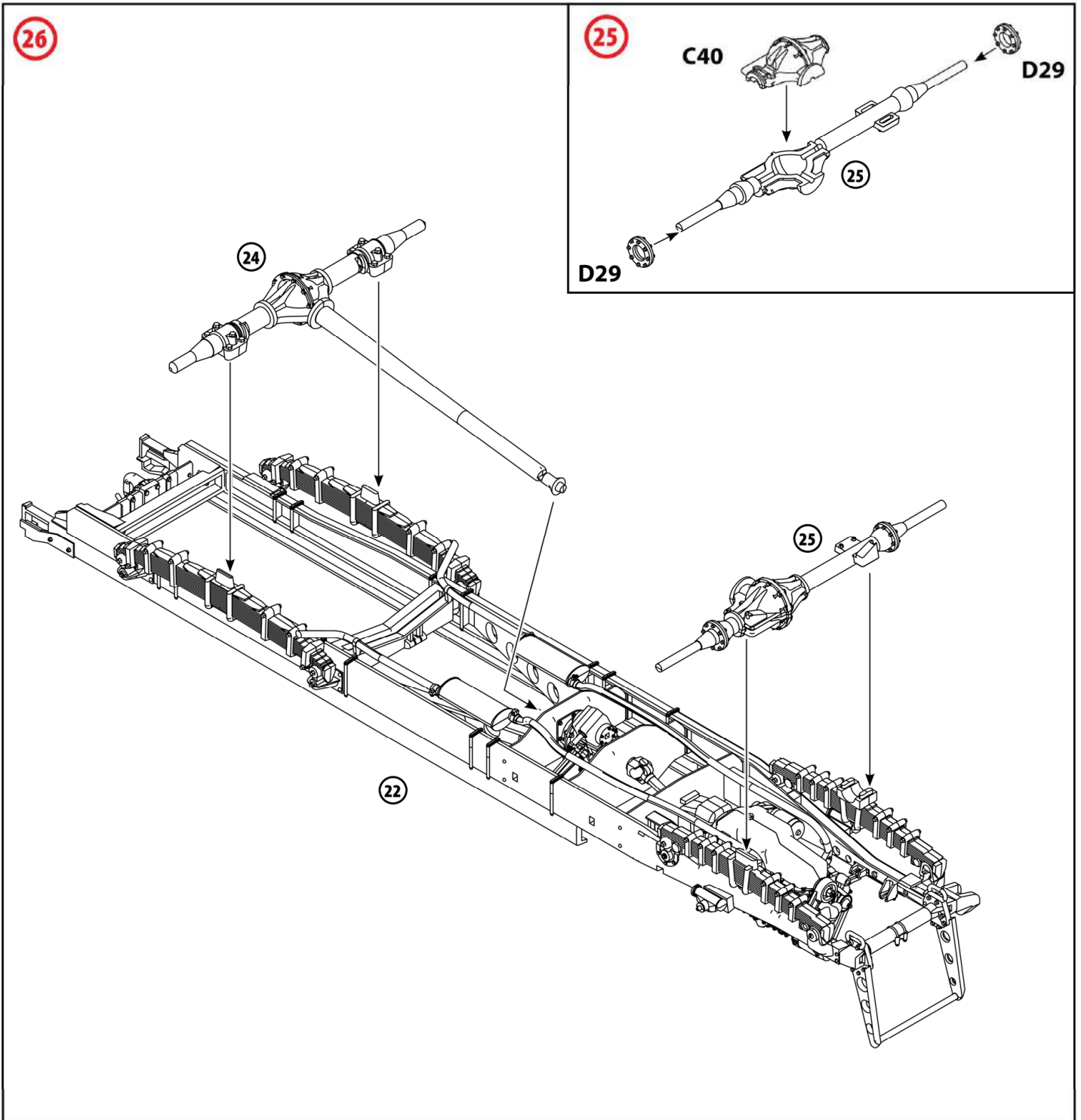
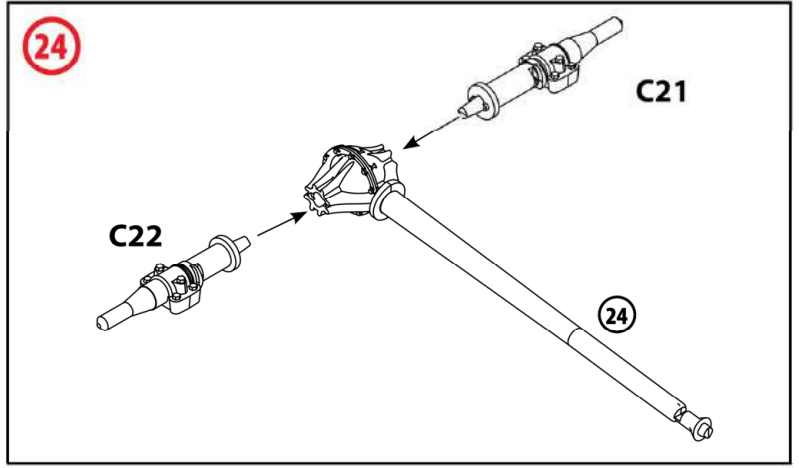
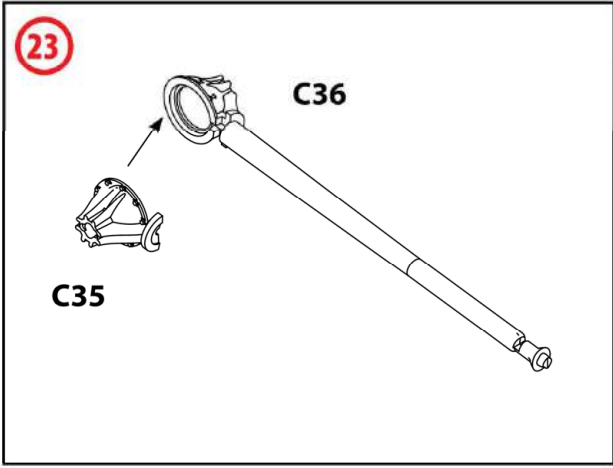

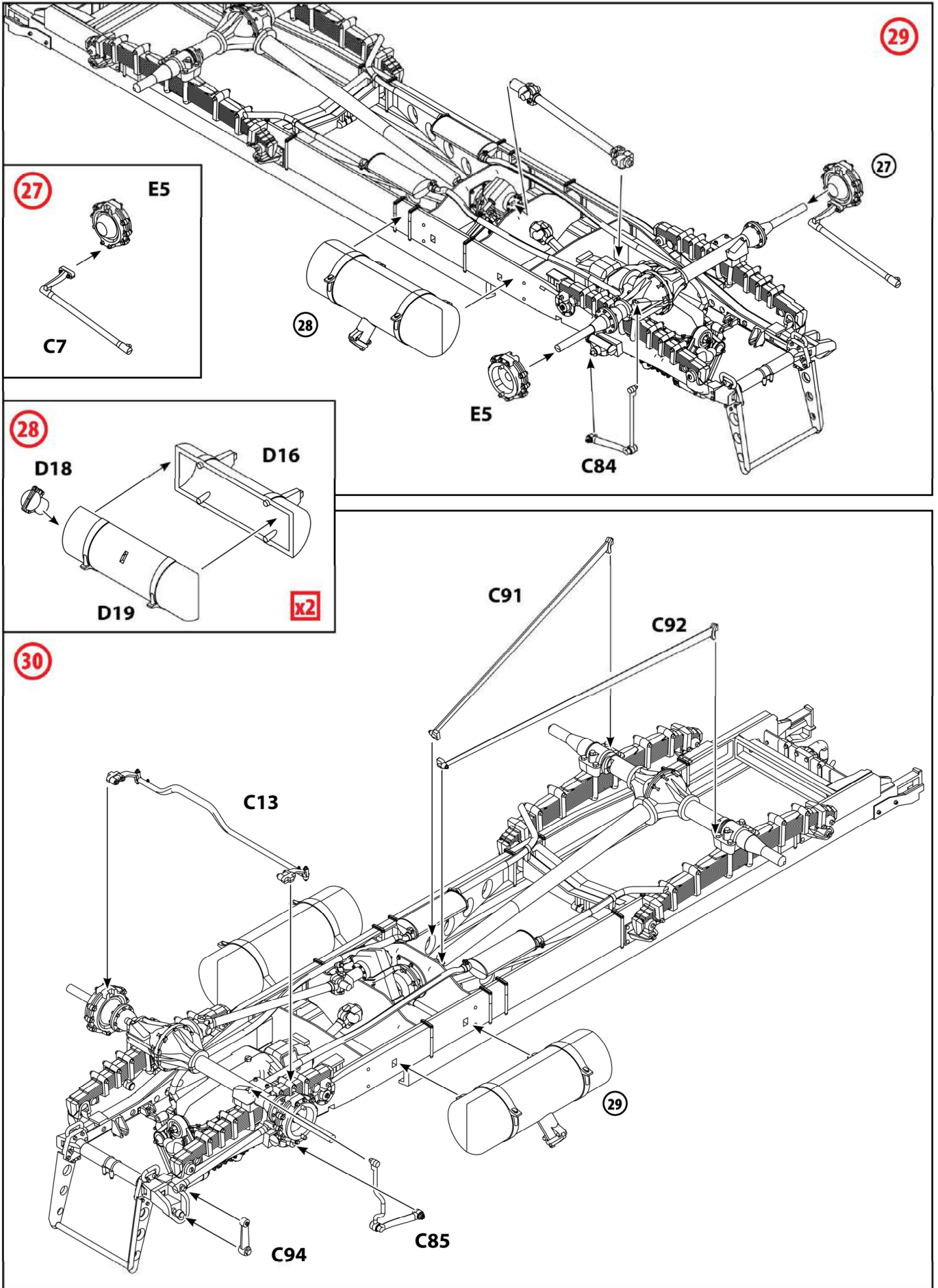

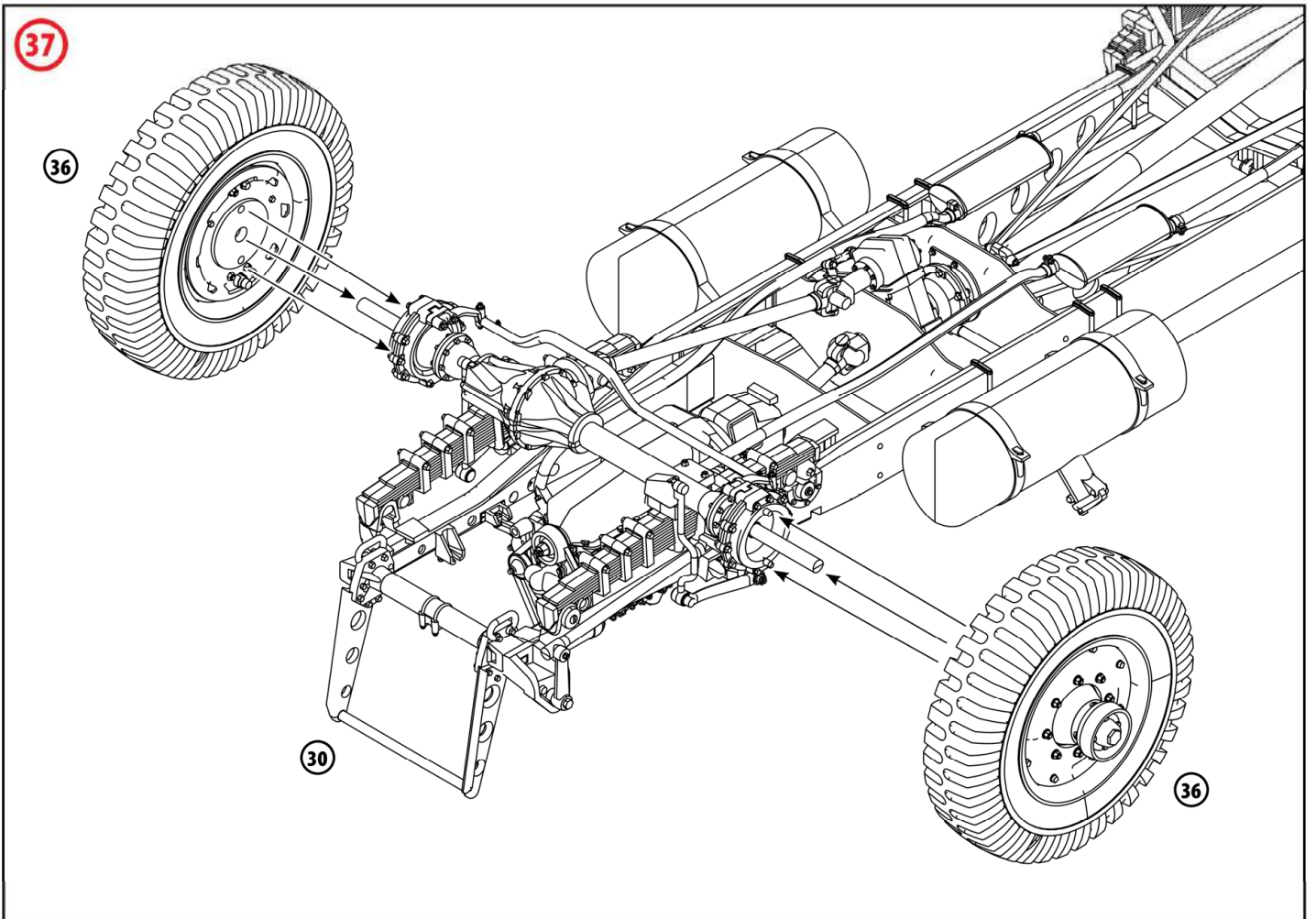
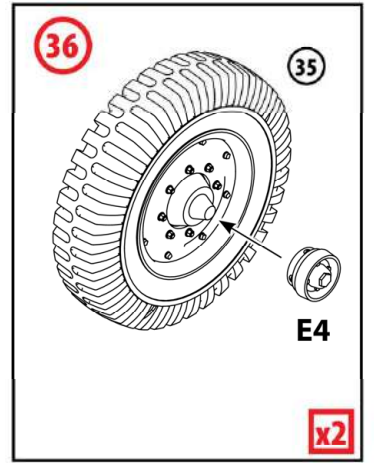
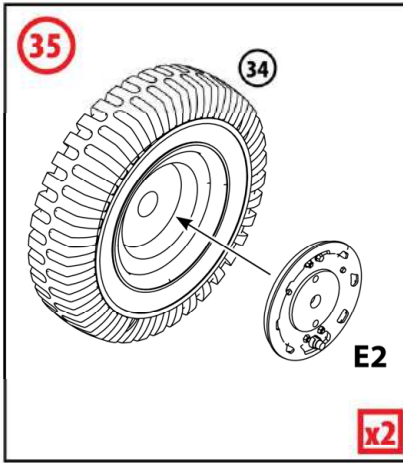
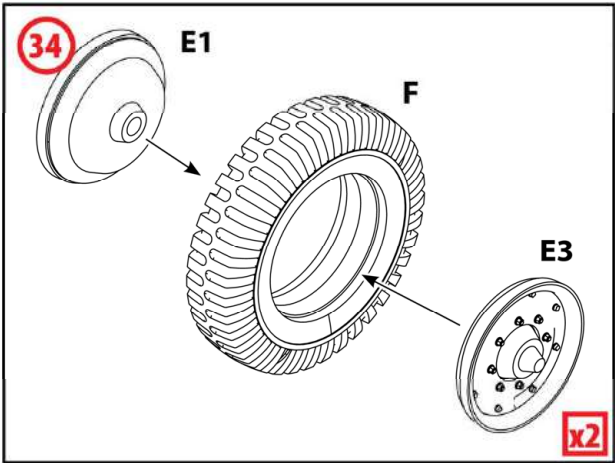
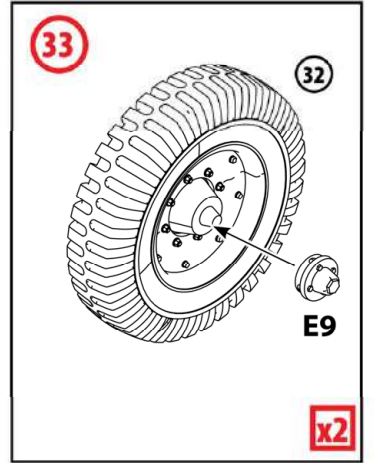
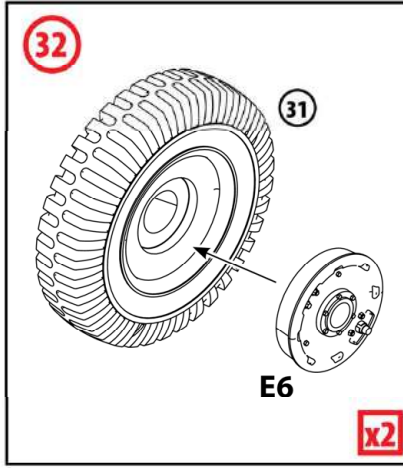
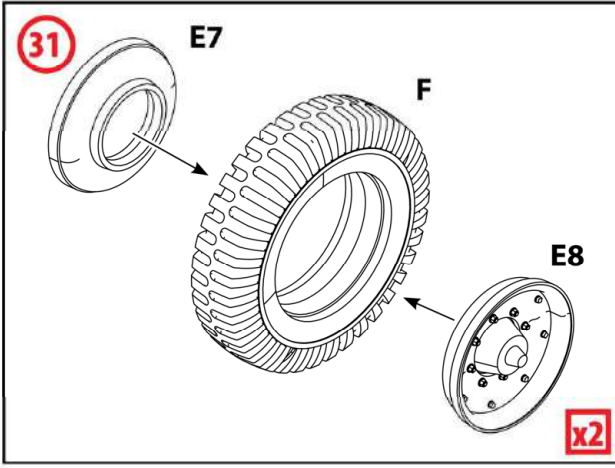

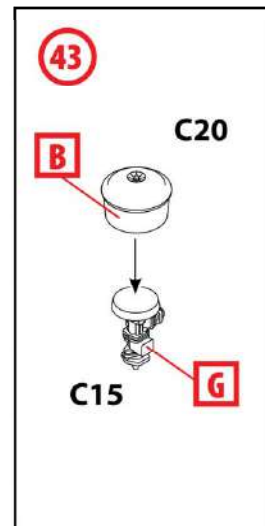
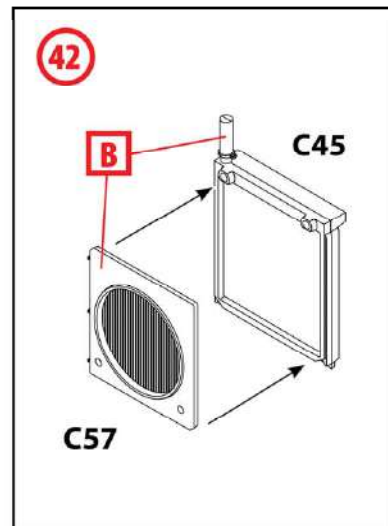
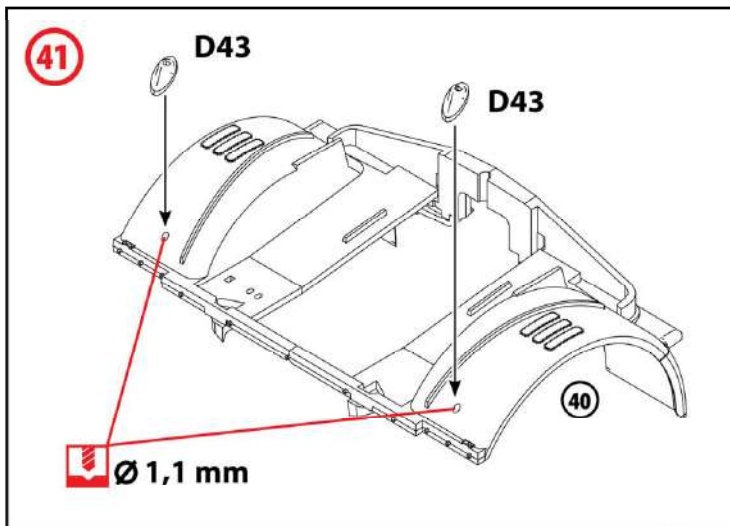
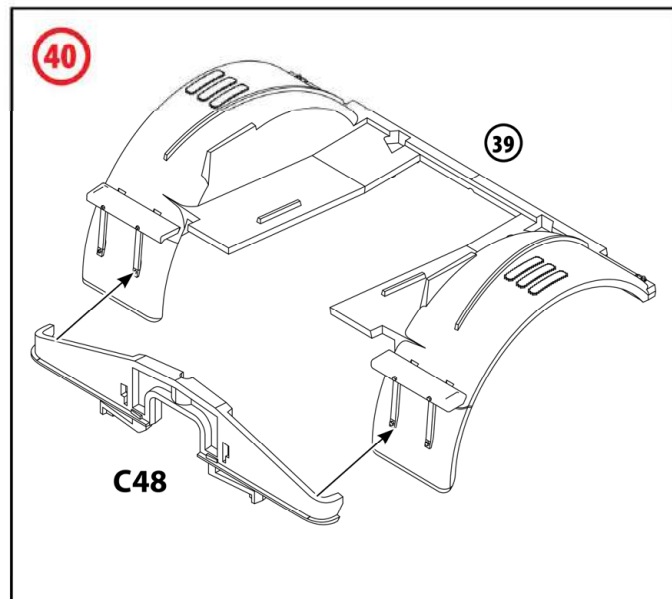
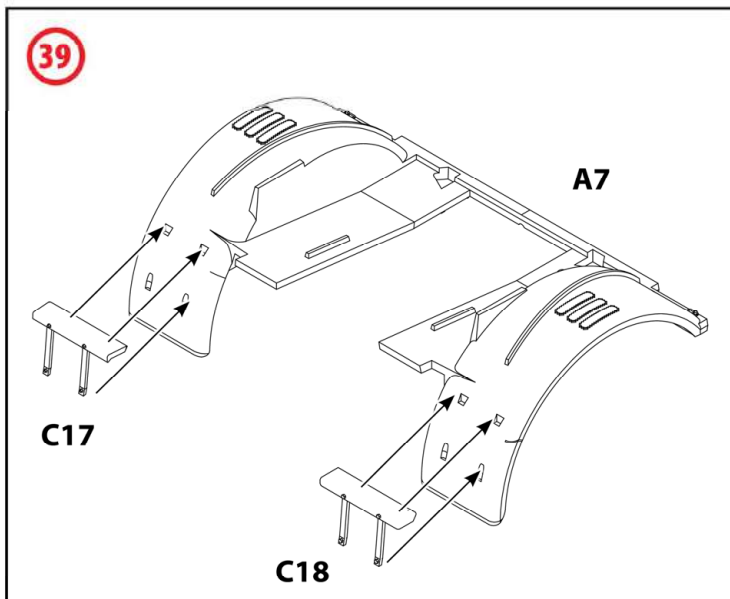
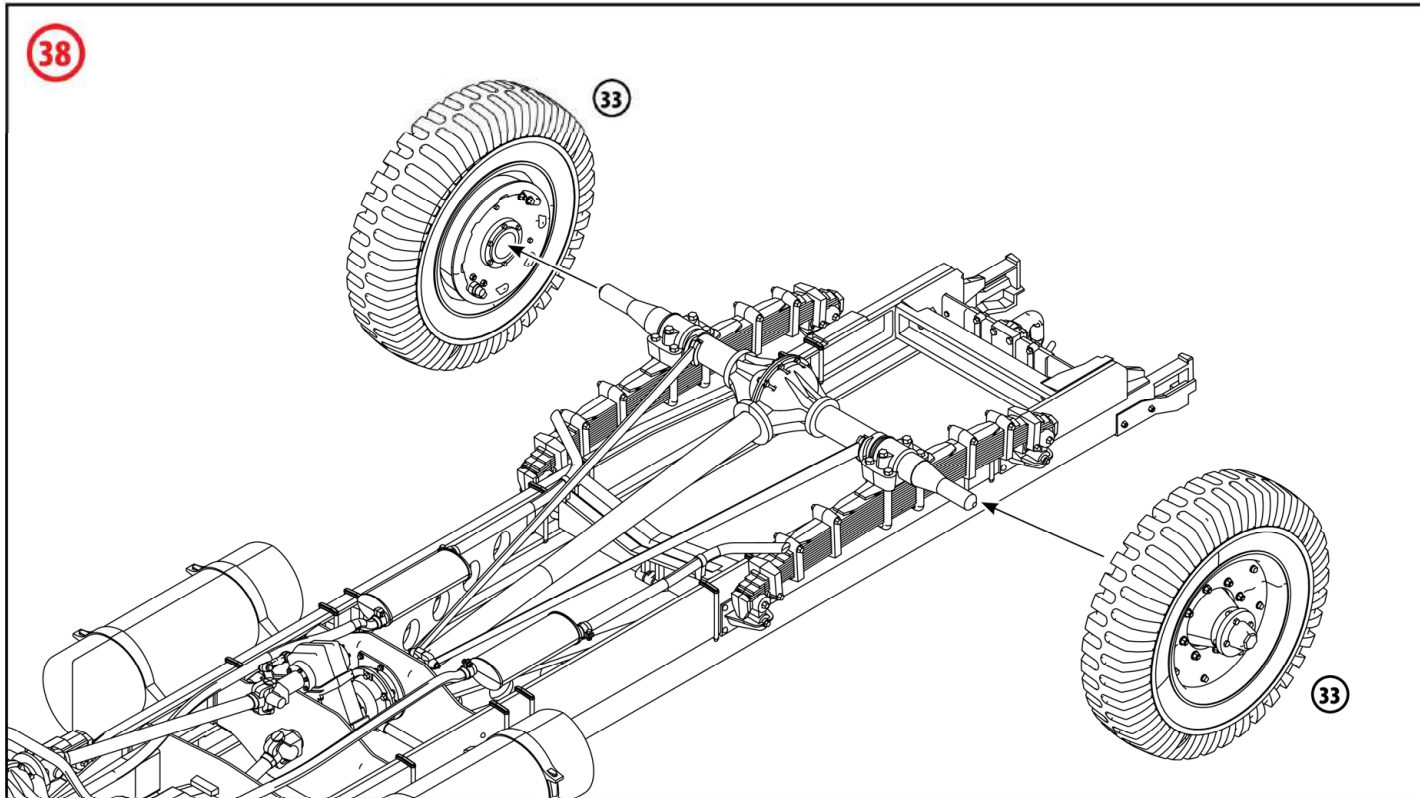

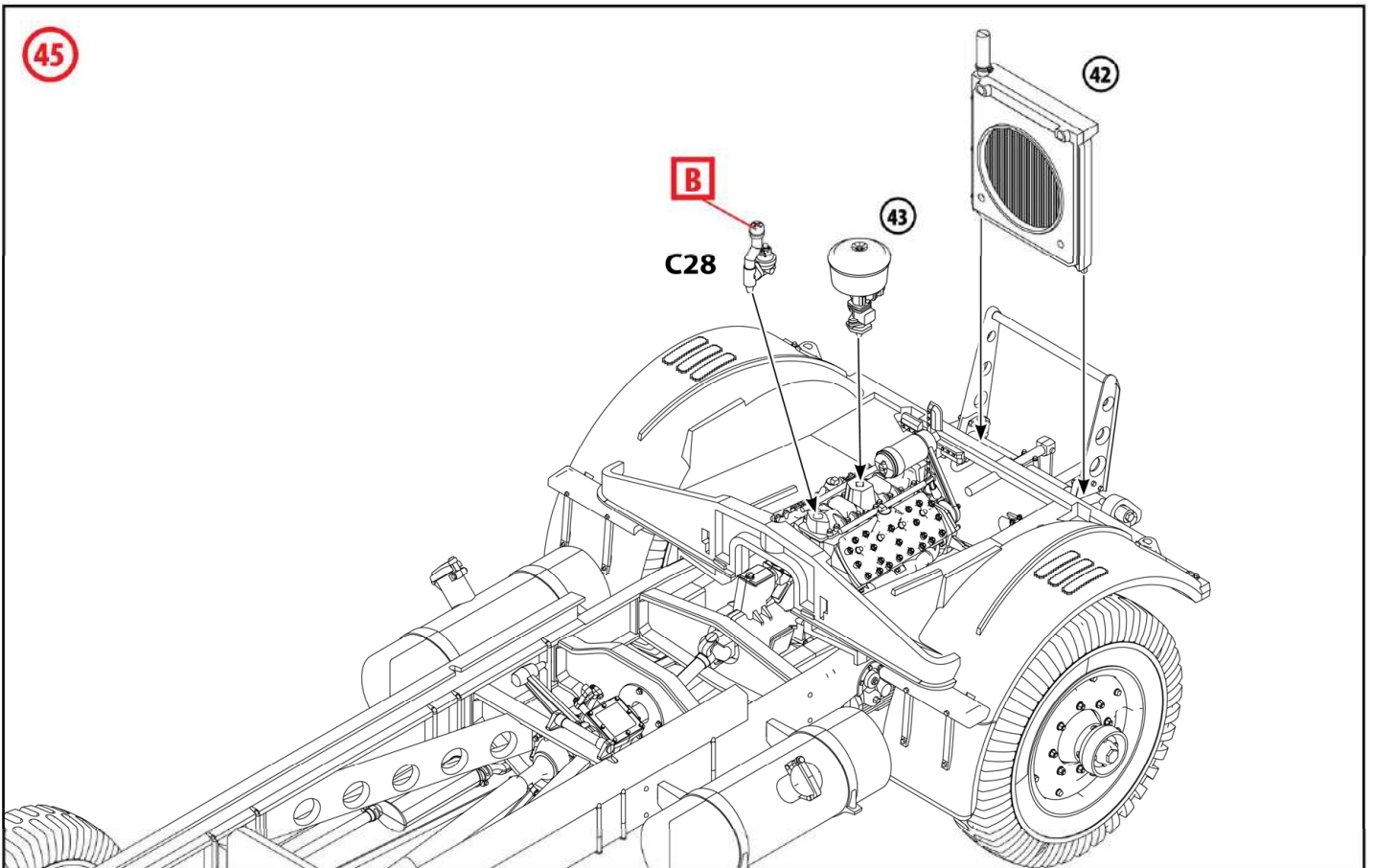
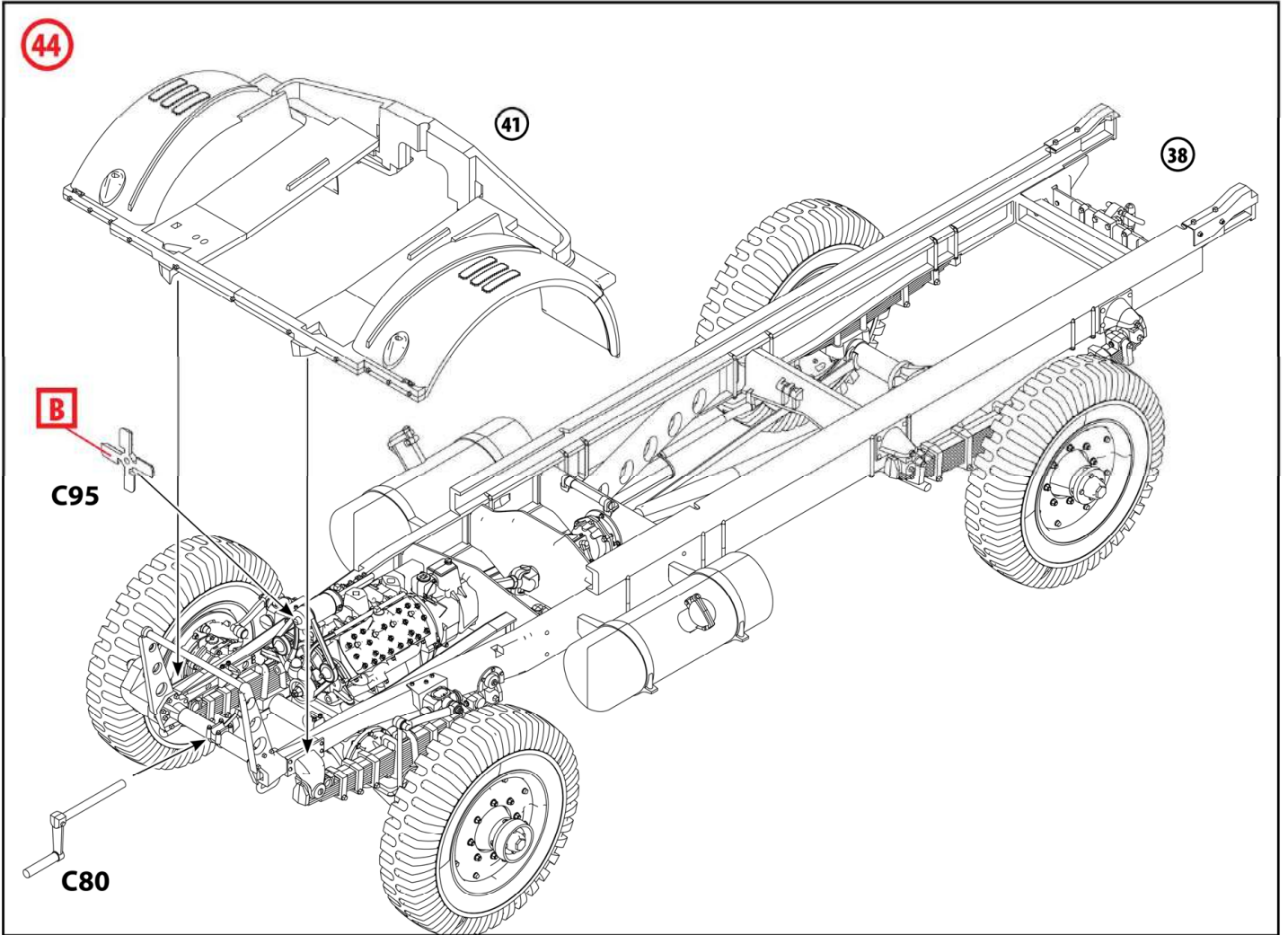

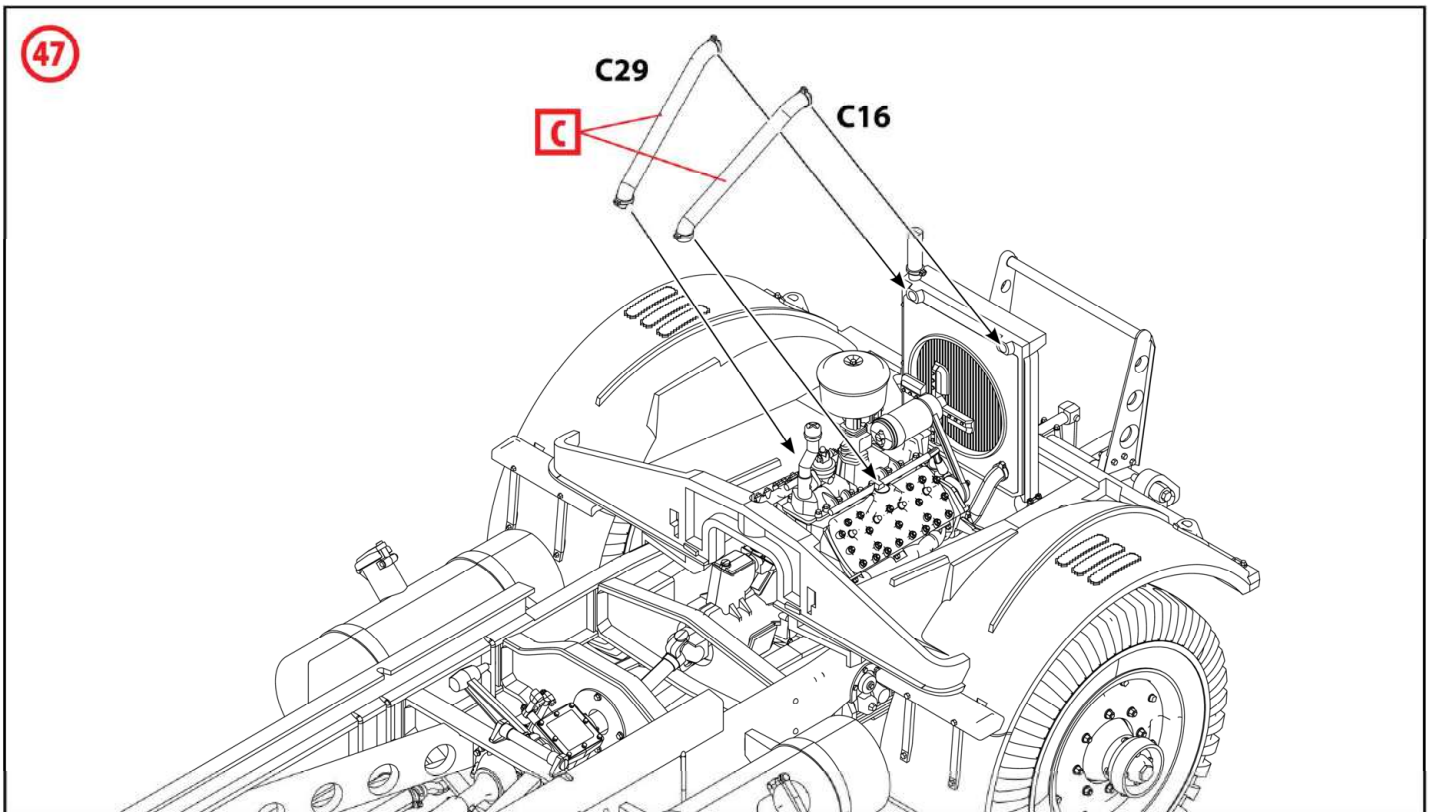
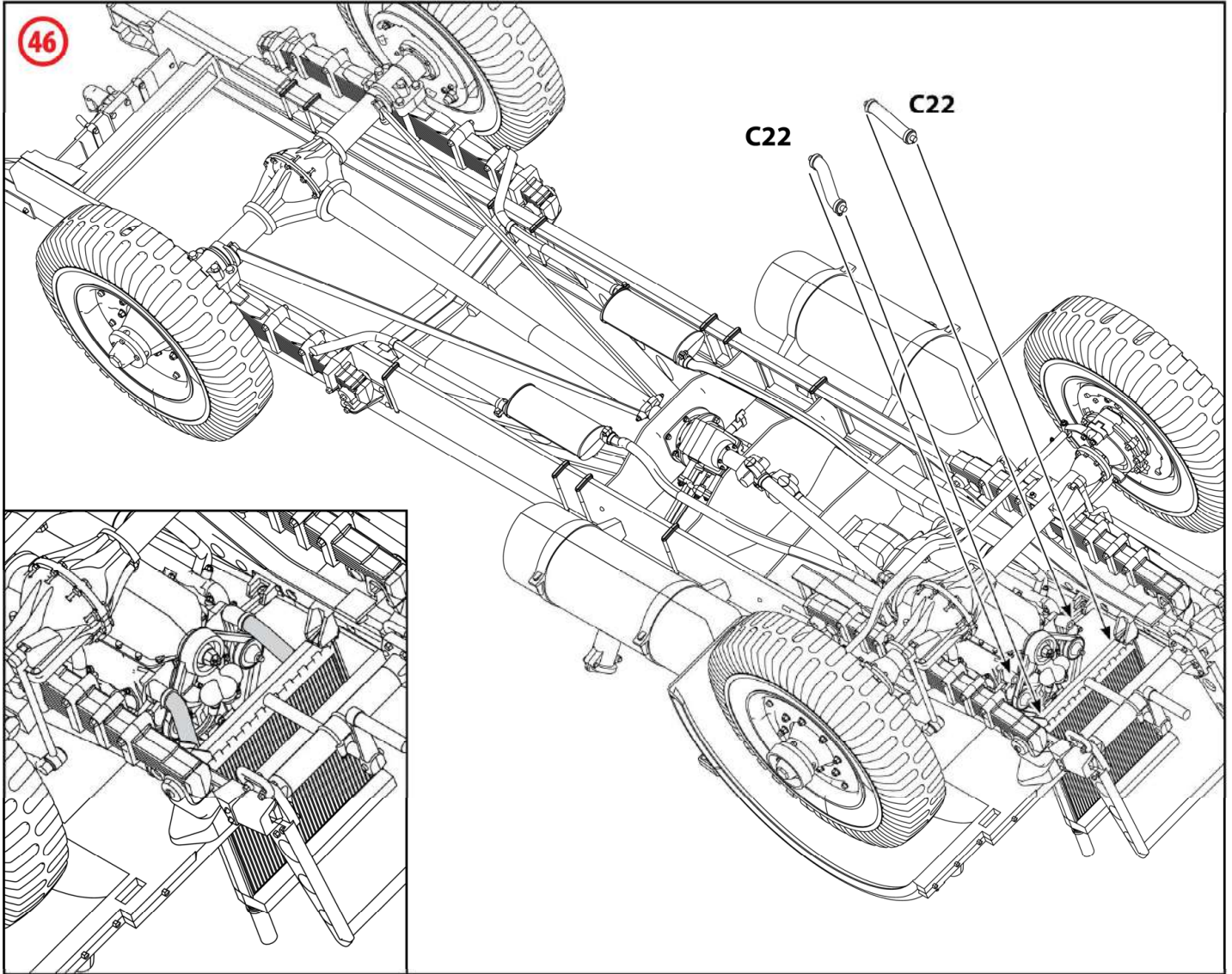

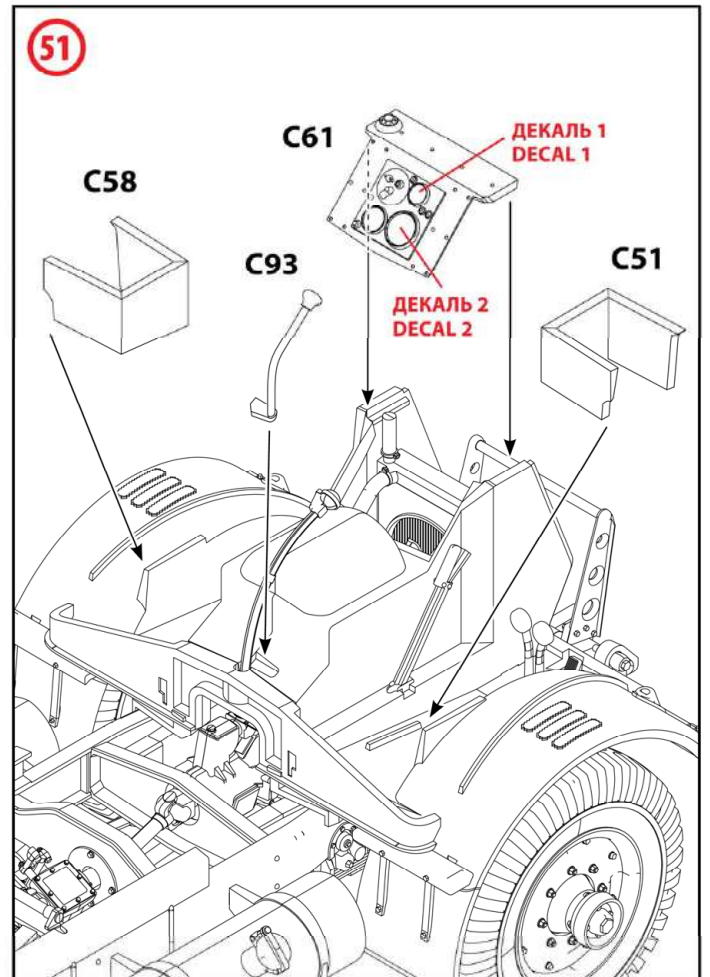
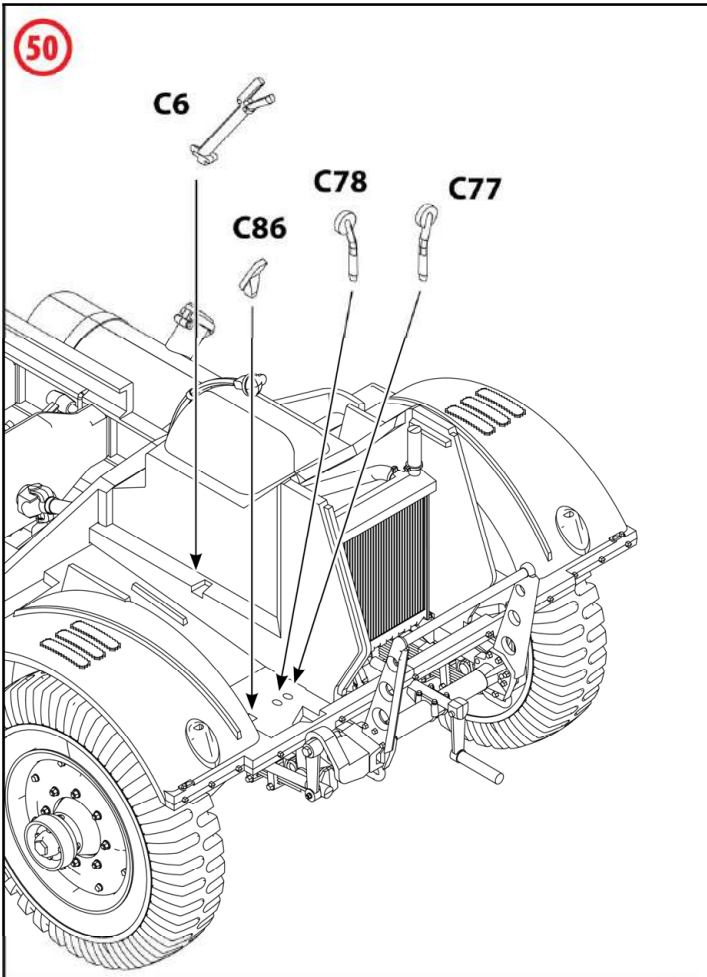
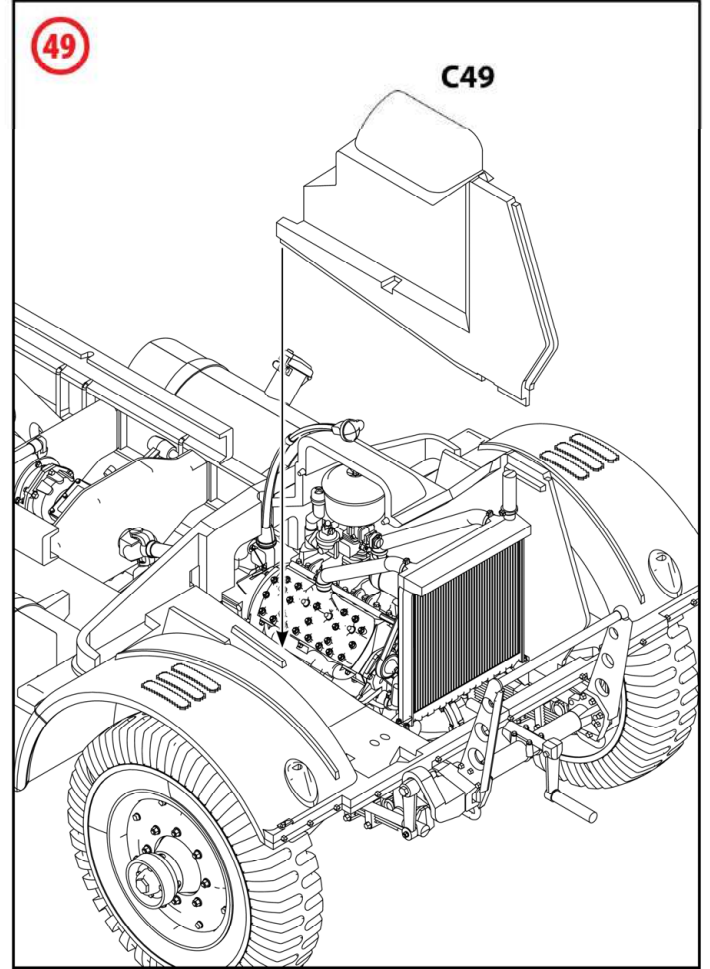
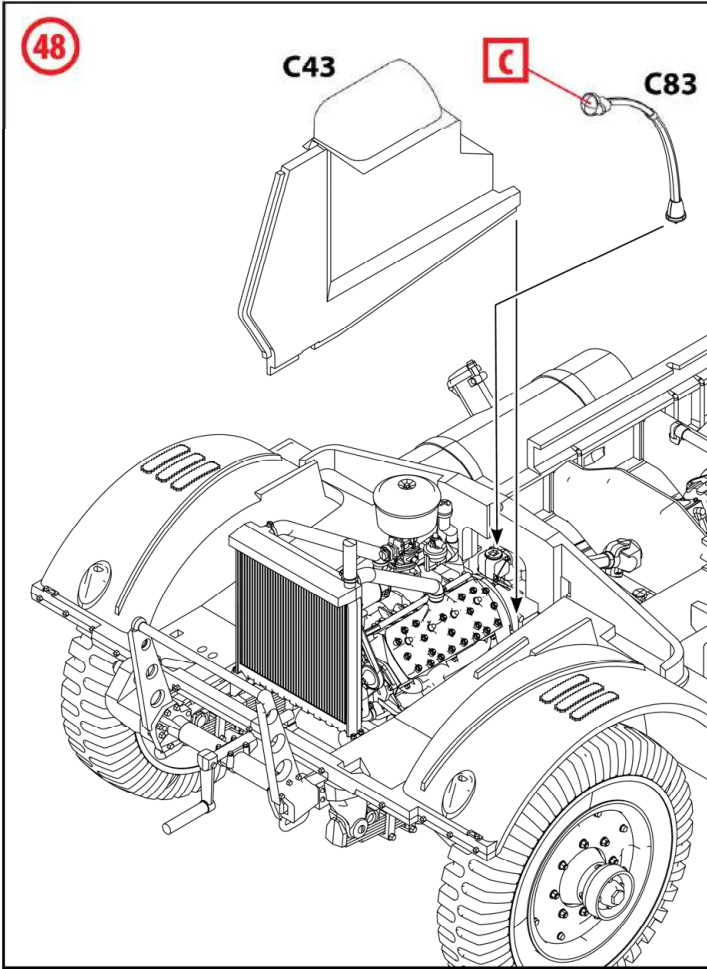

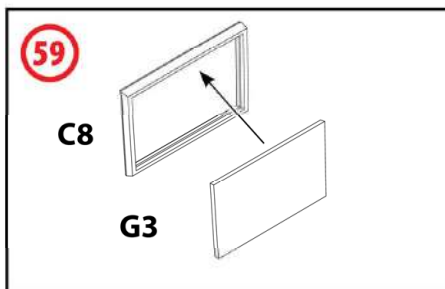
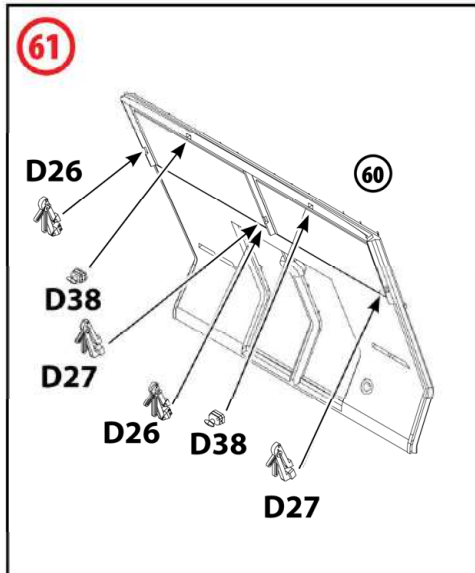
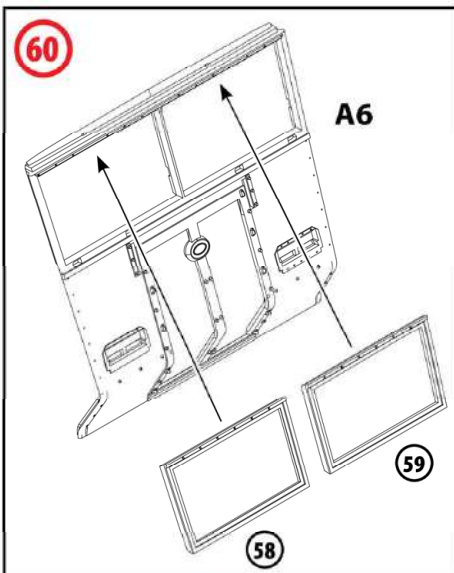
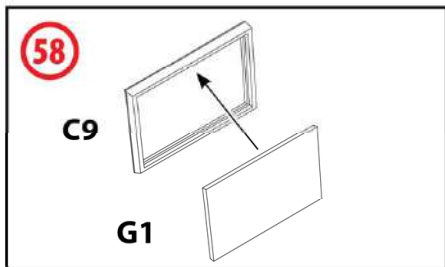
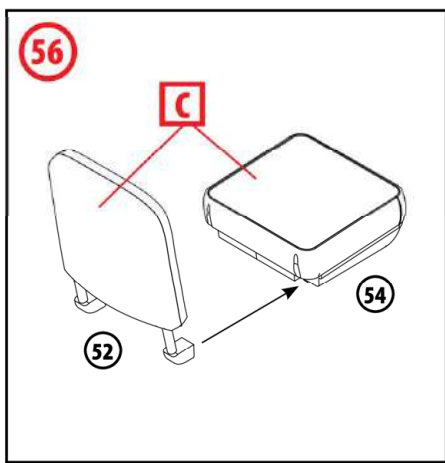
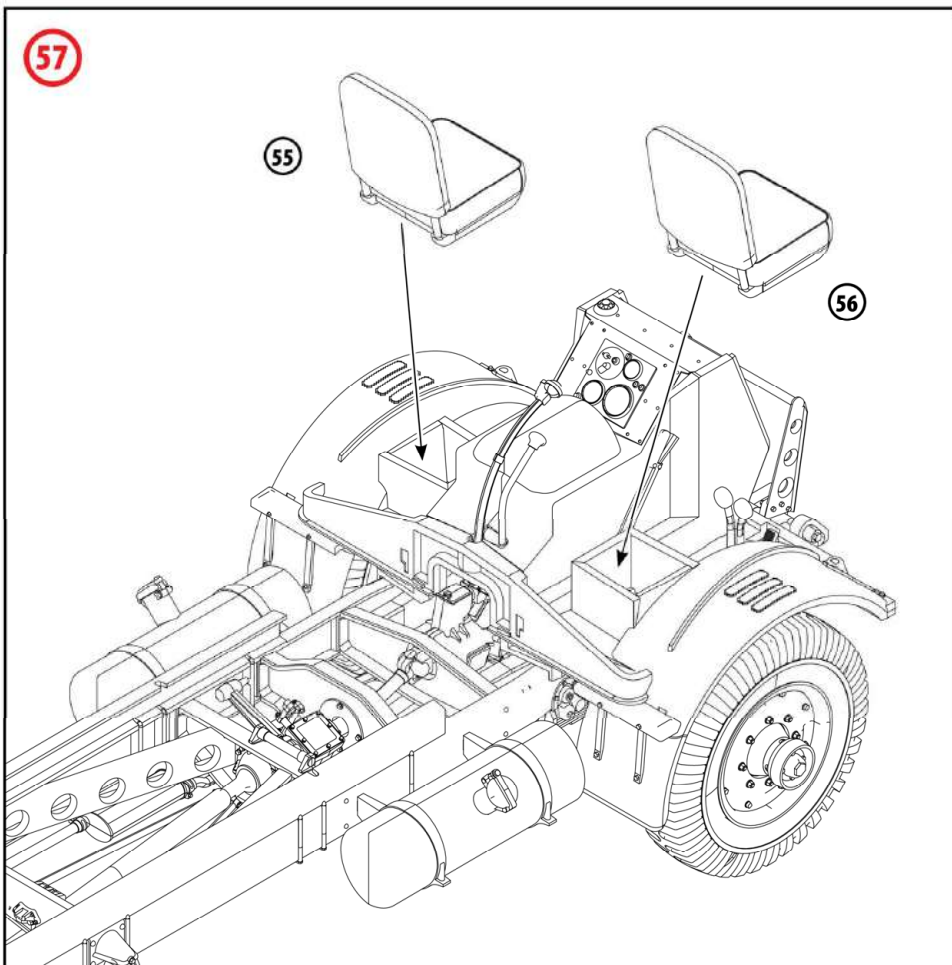
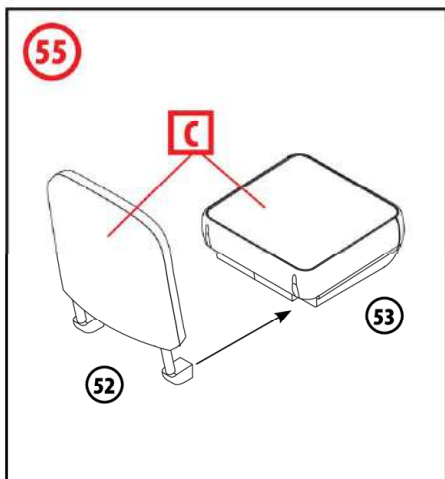
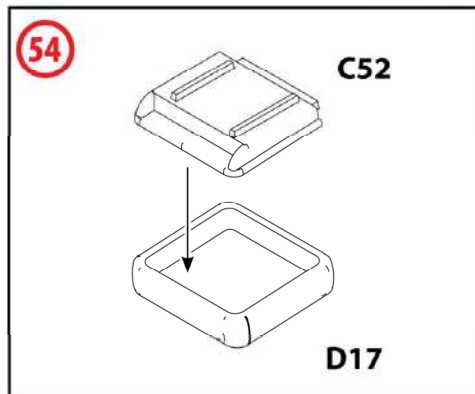
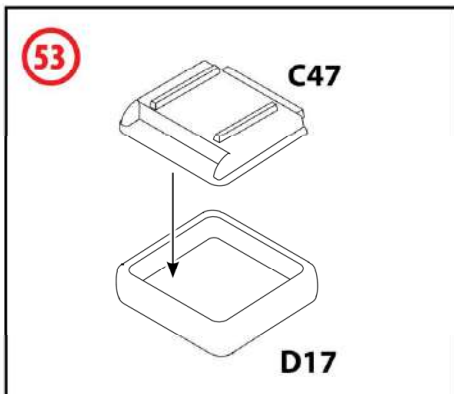
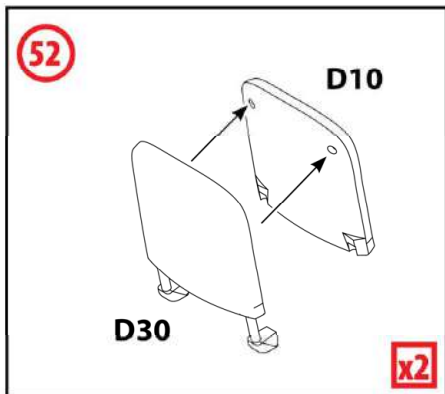

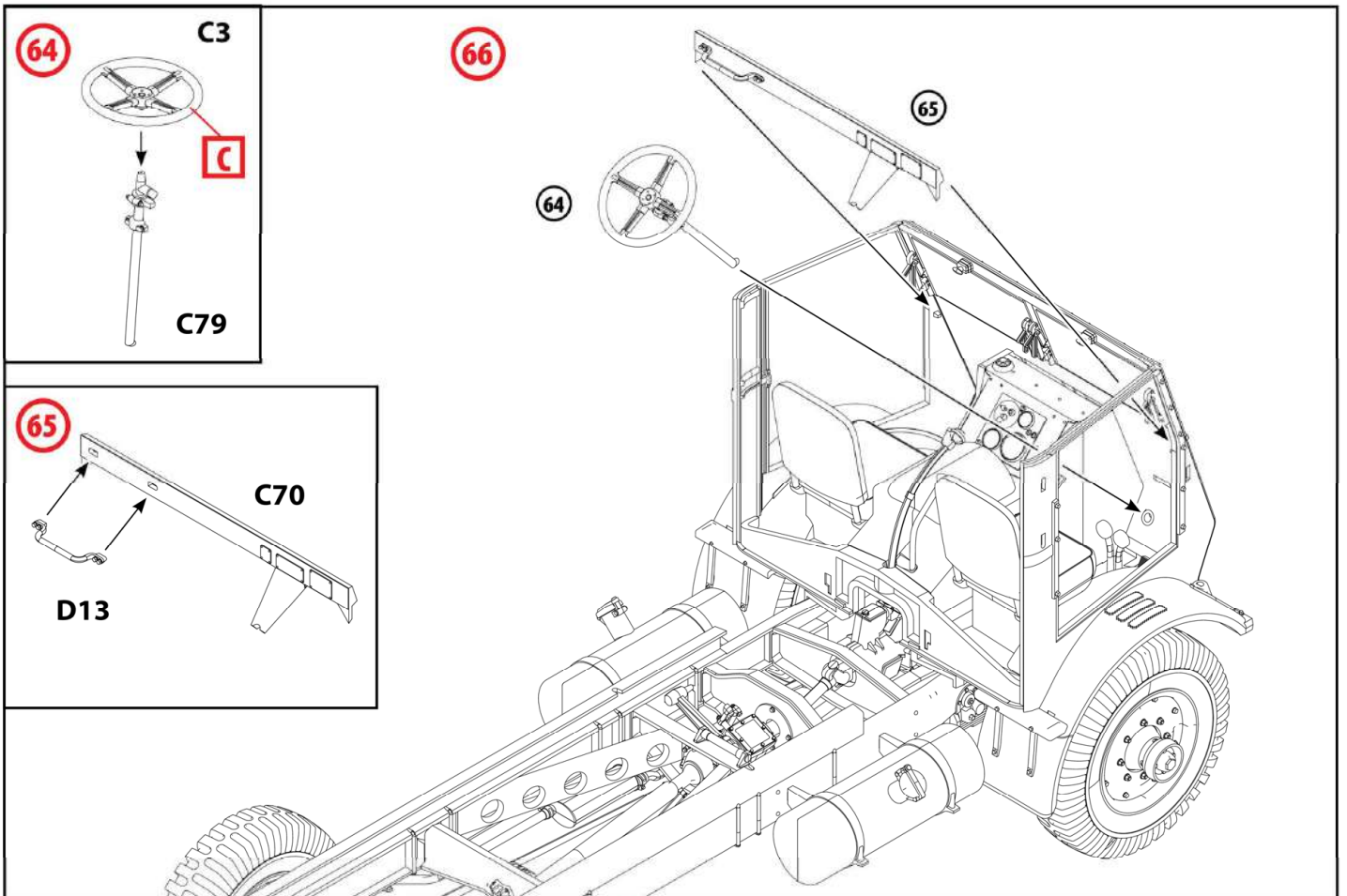
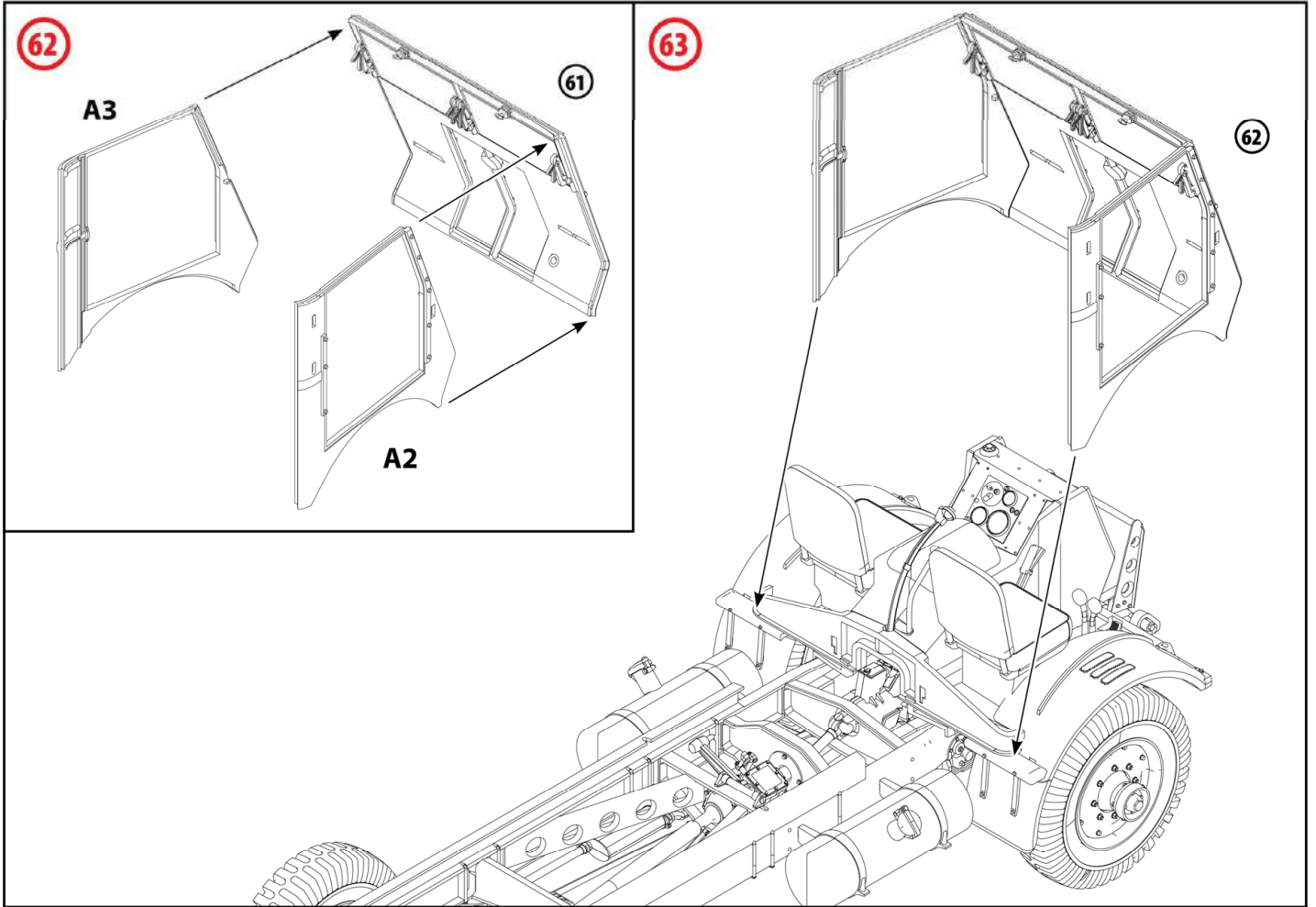

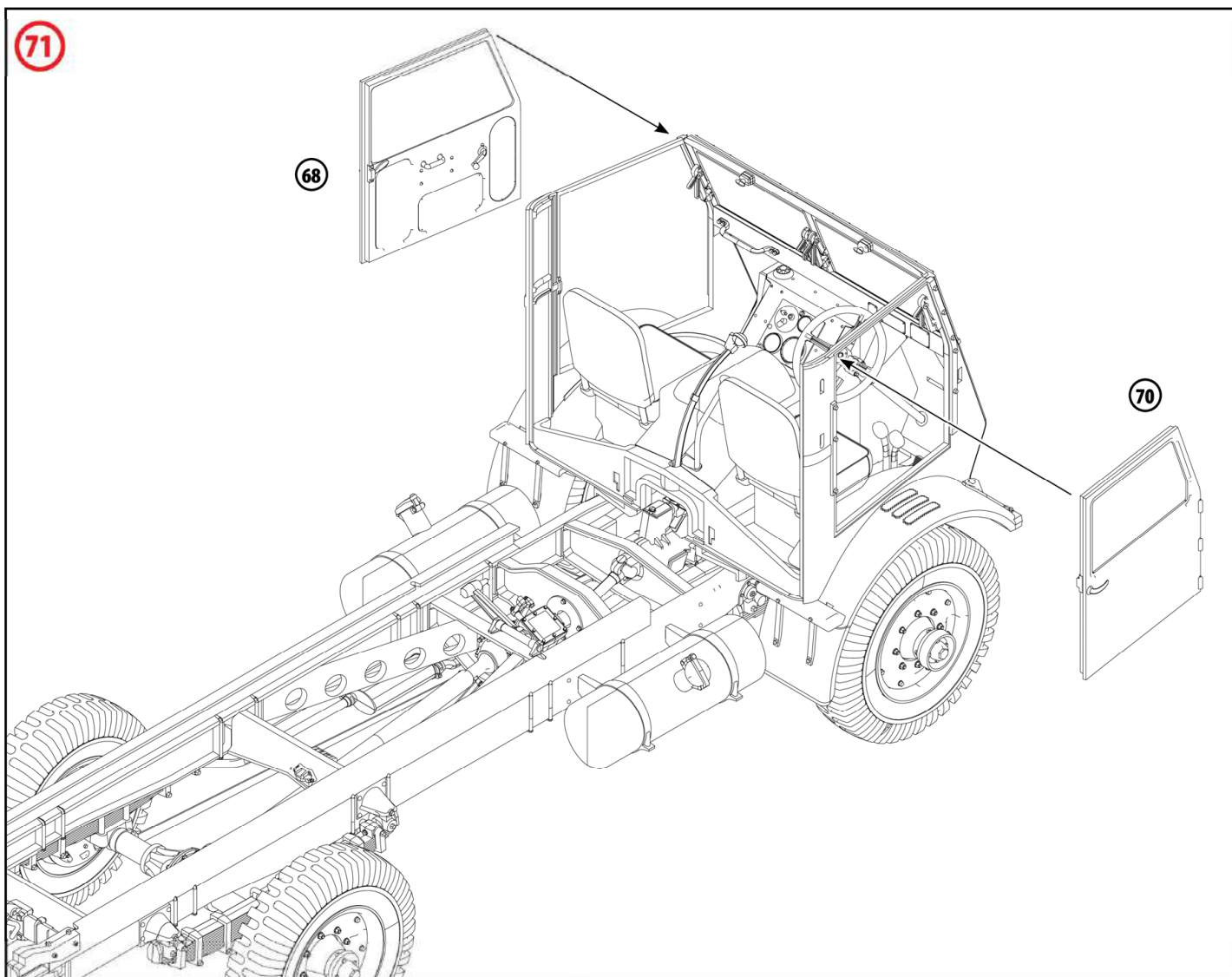
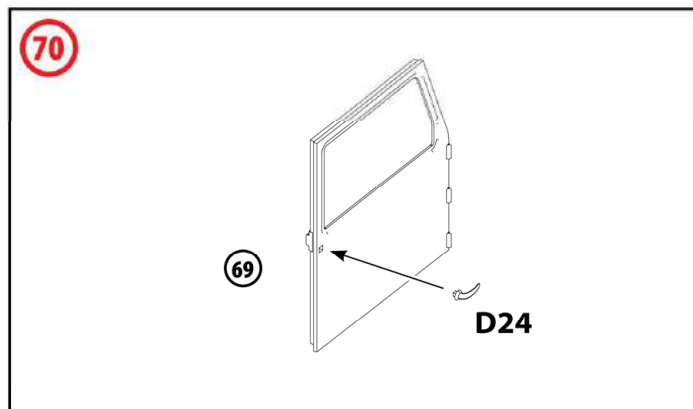
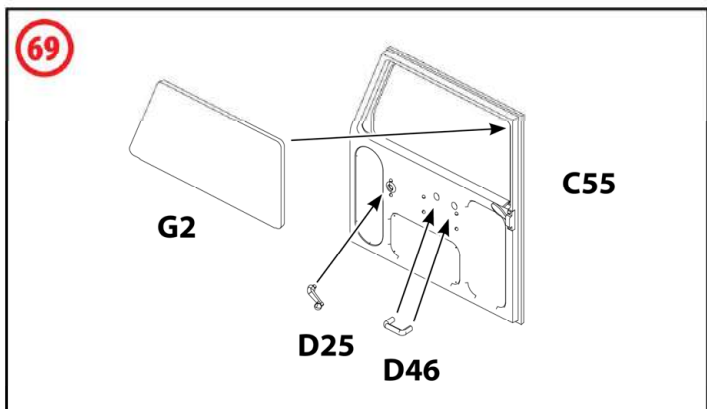
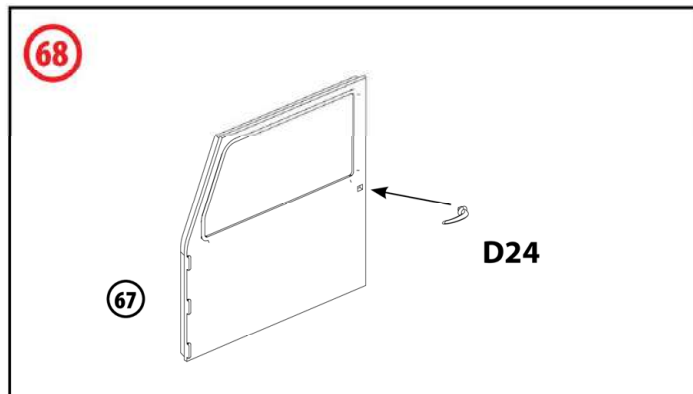
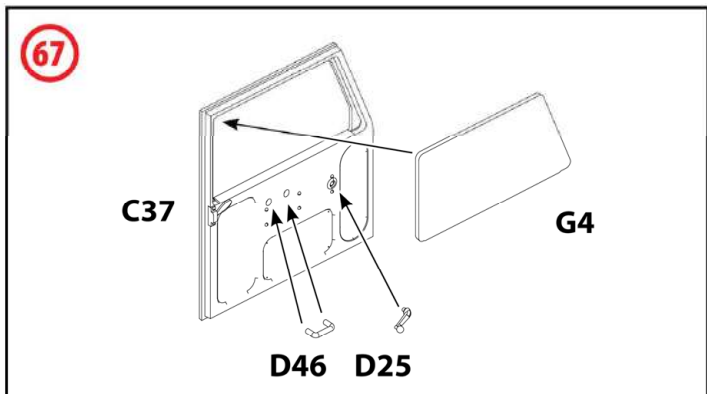

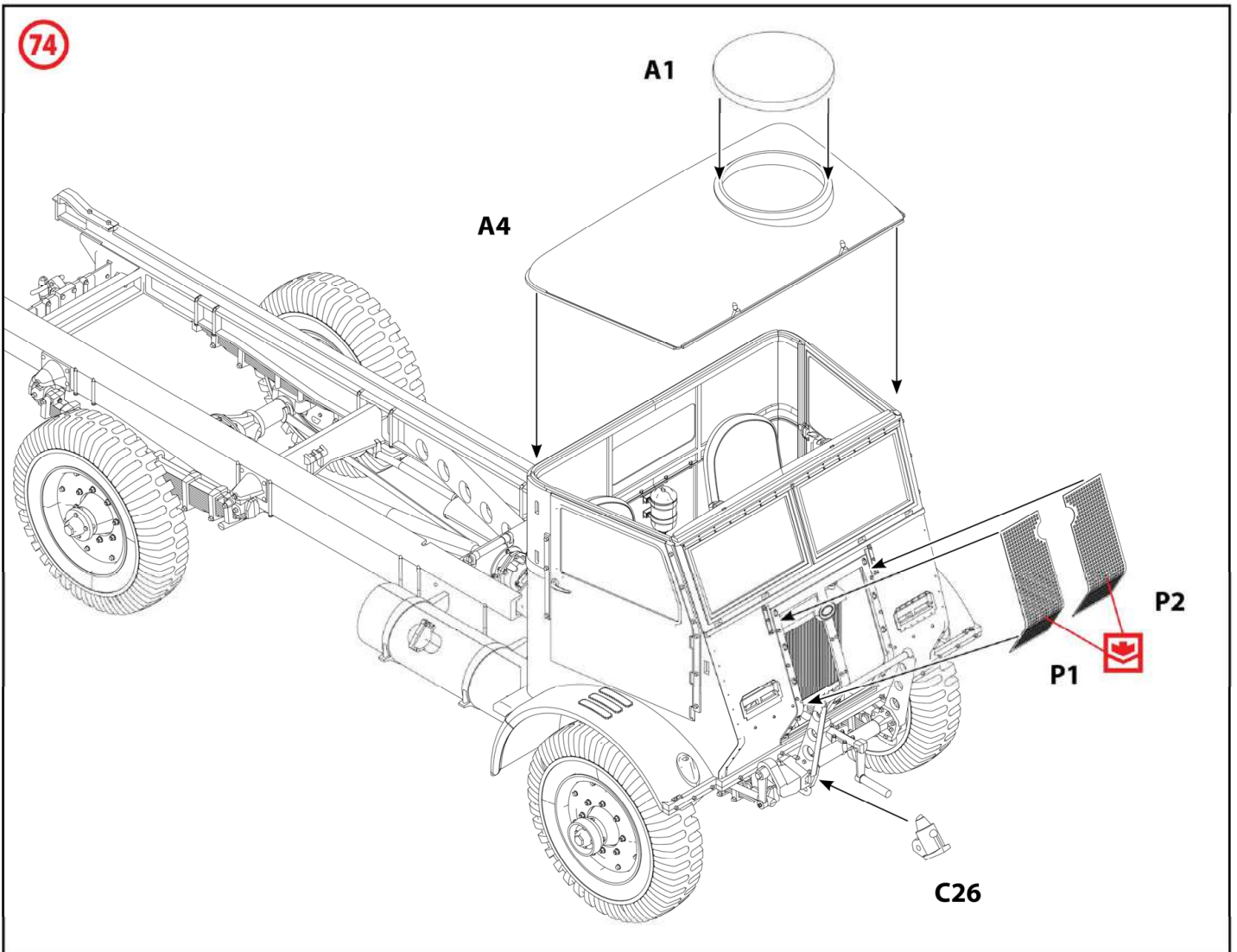
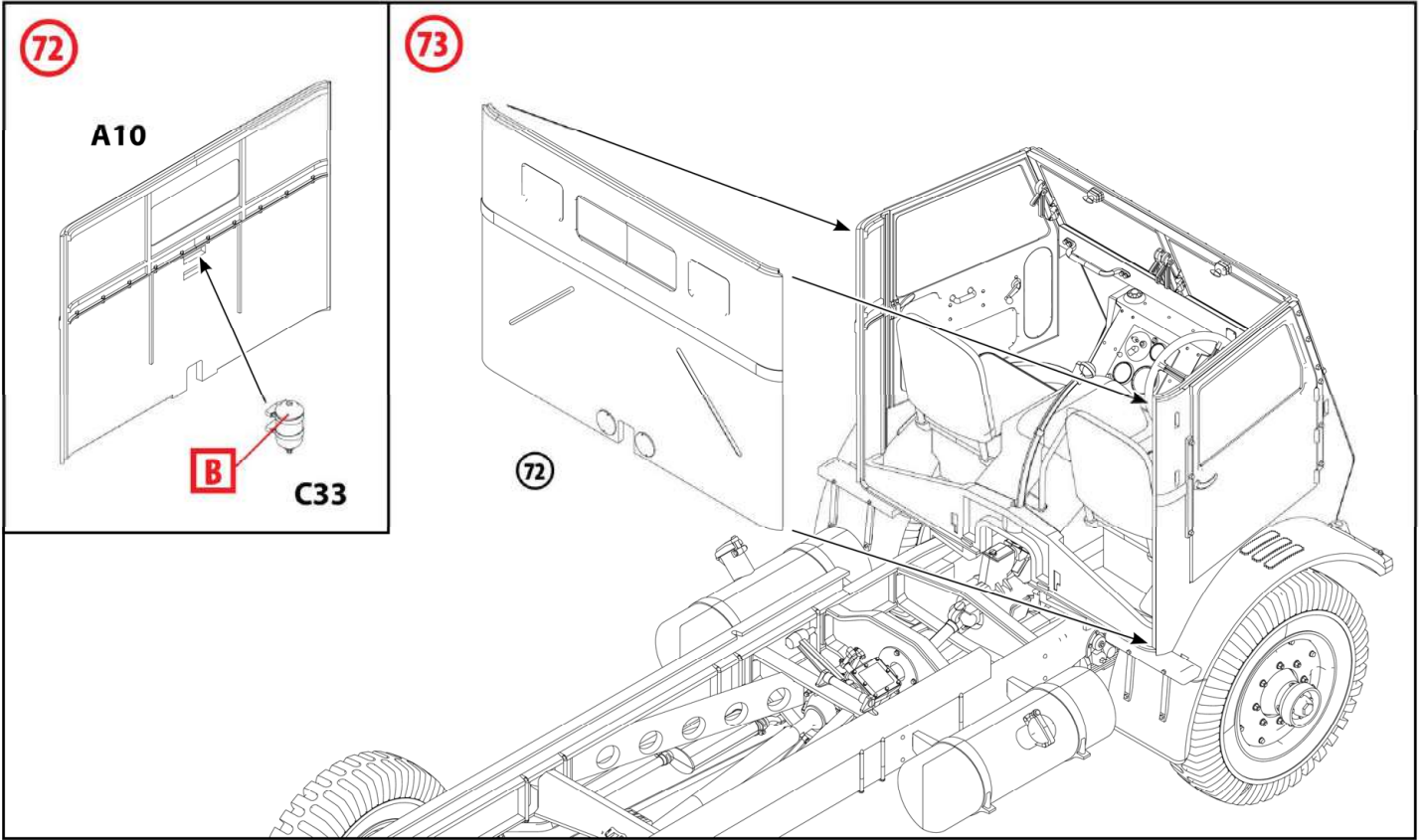

75

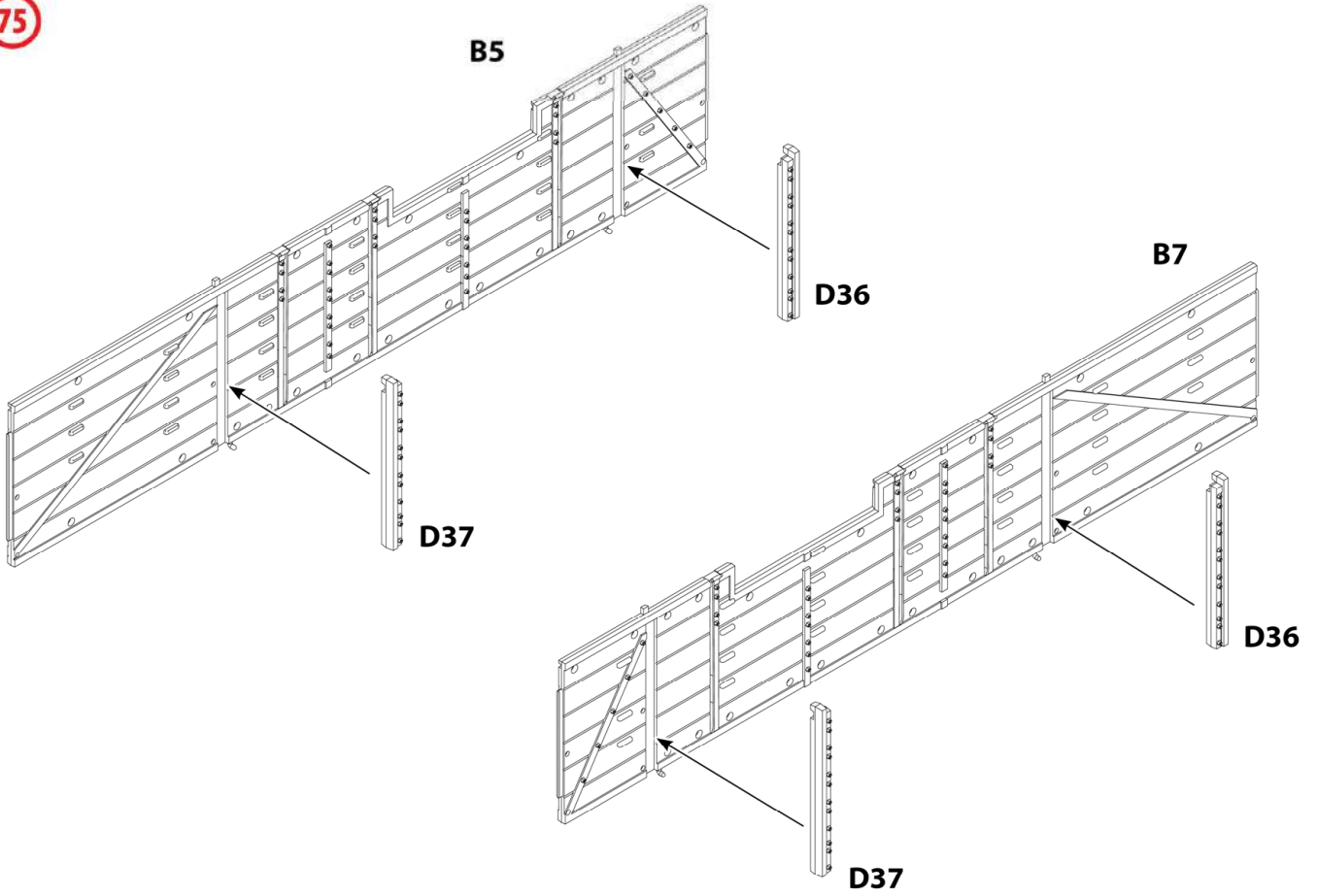

76

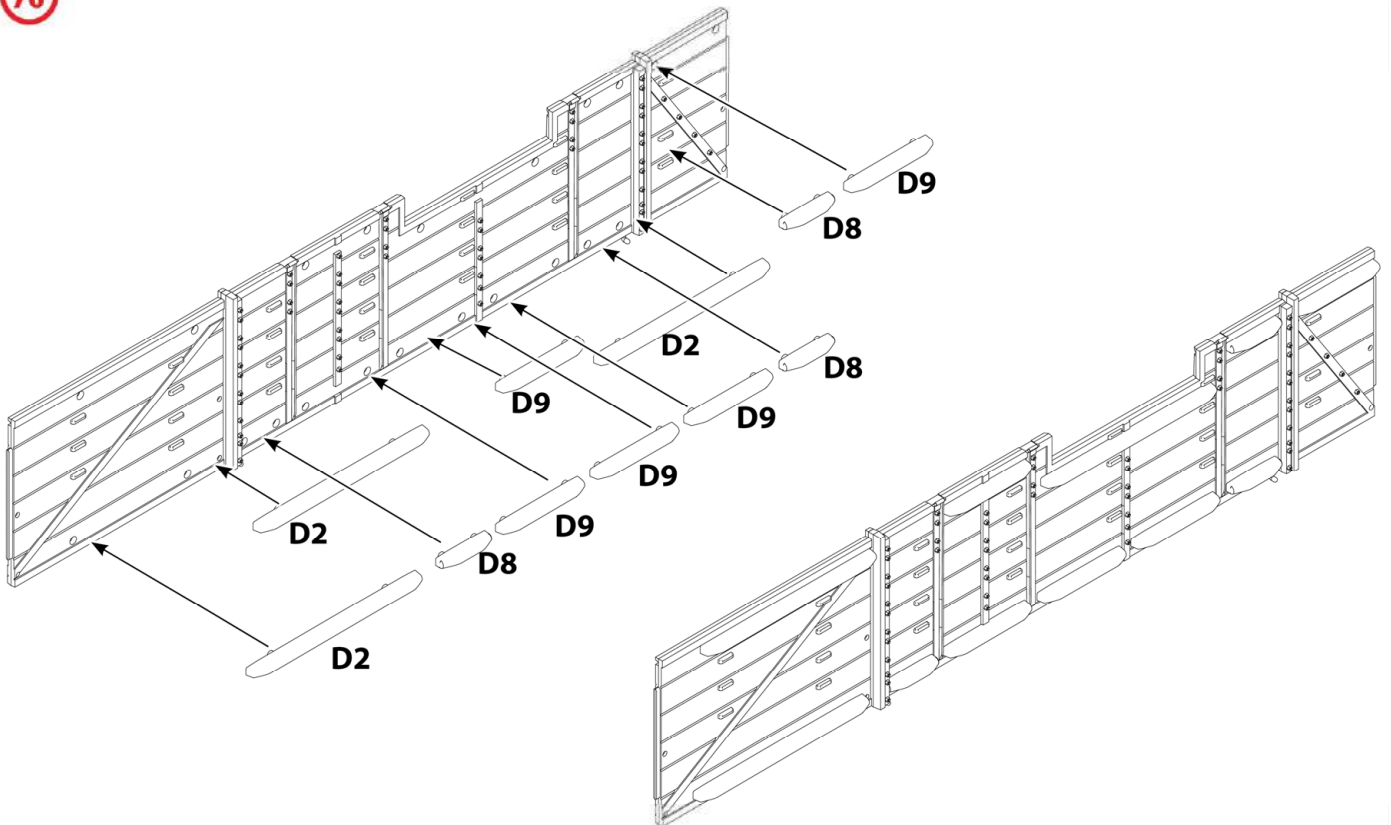

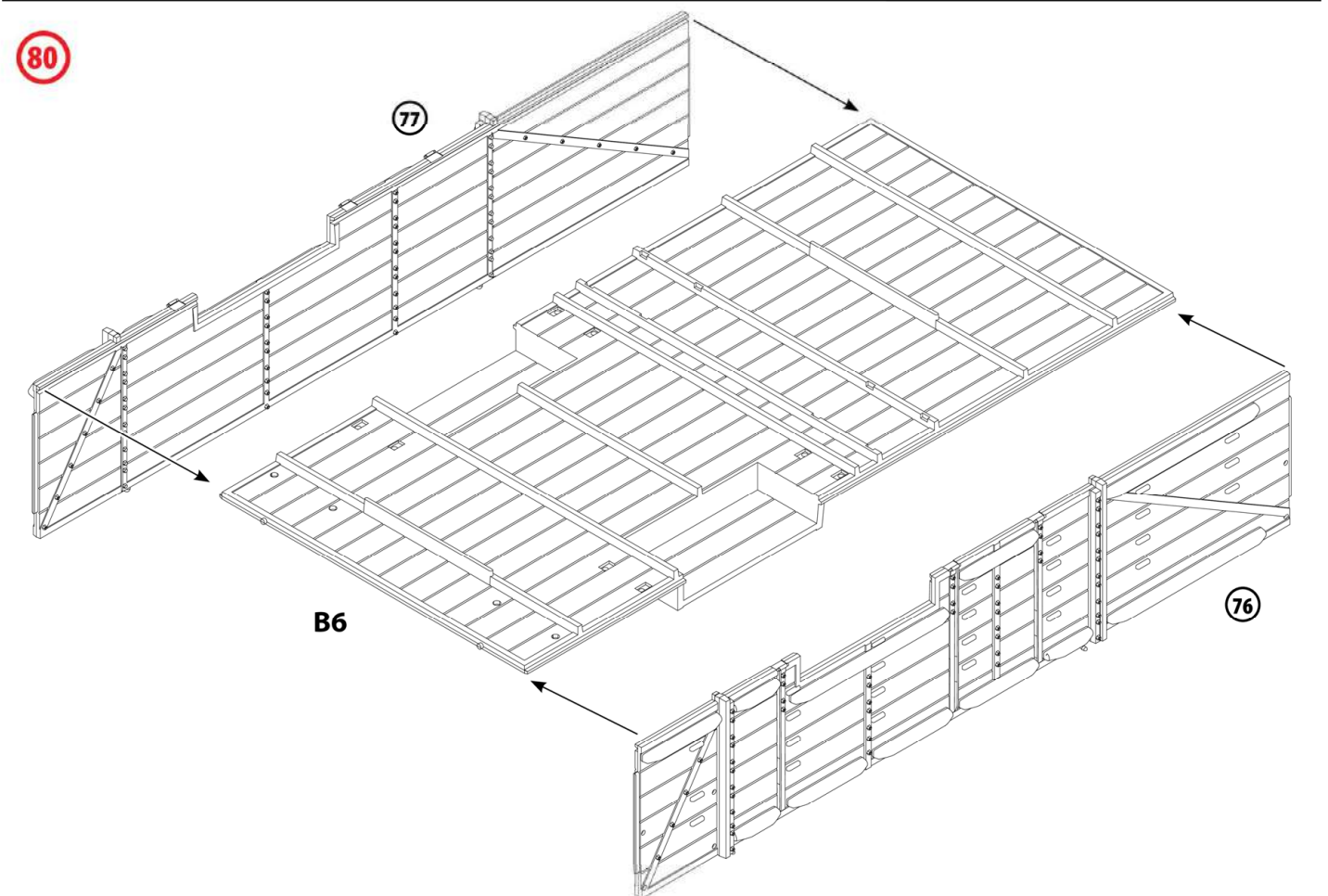
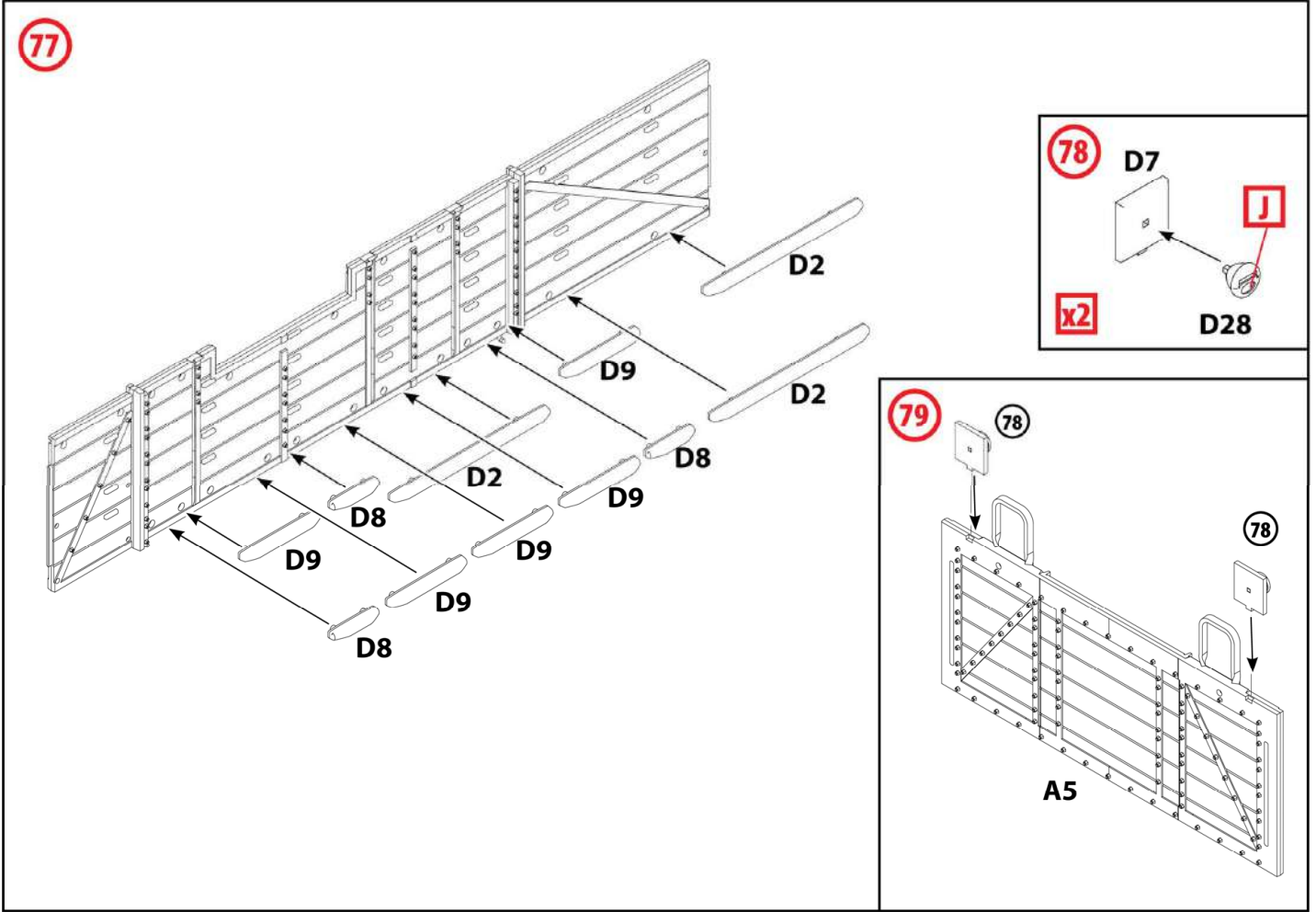

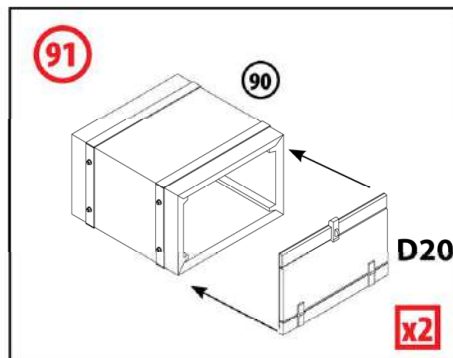
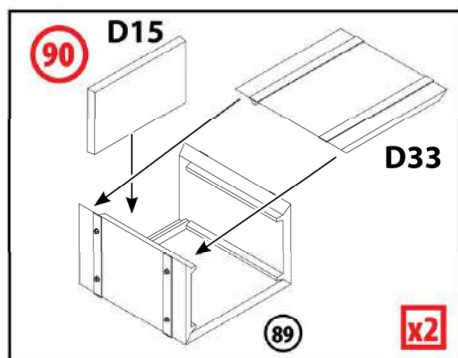
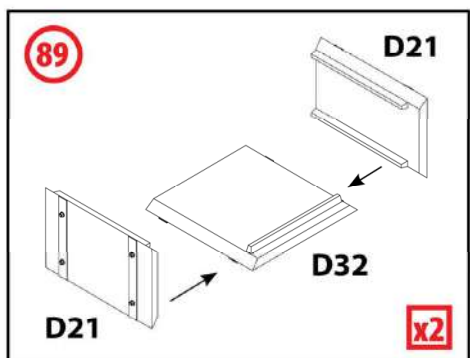
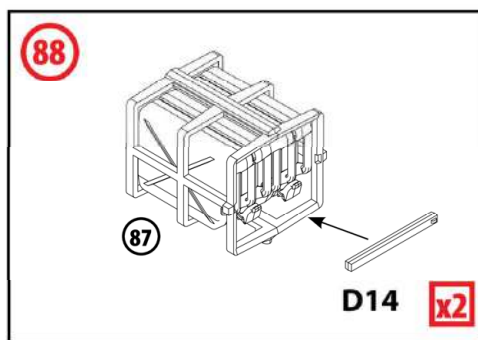
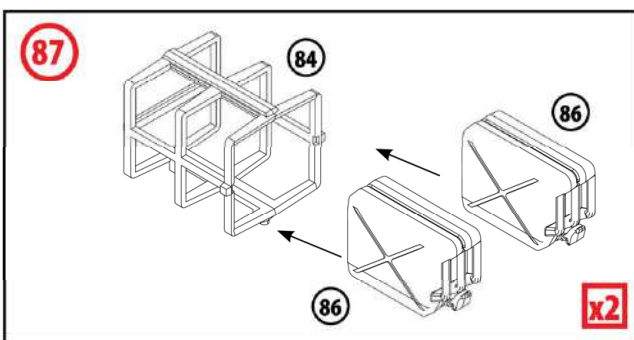
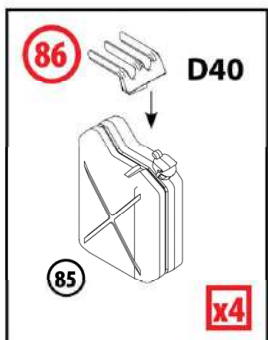
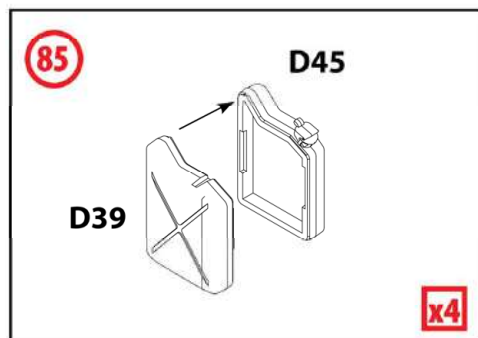
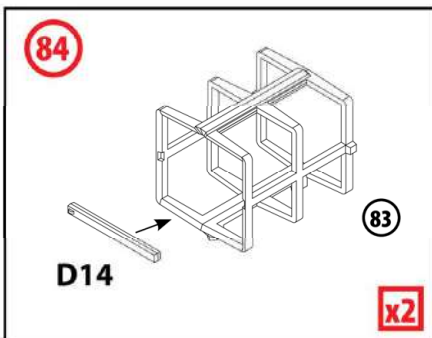
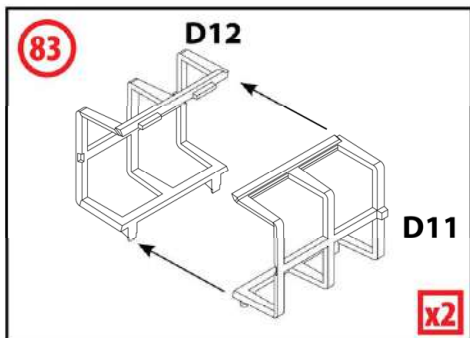
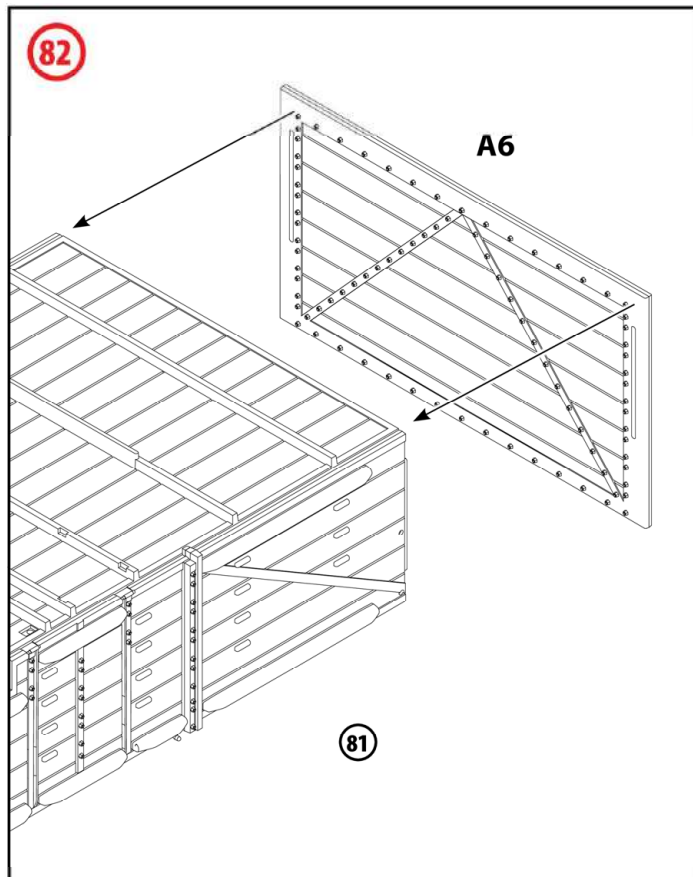
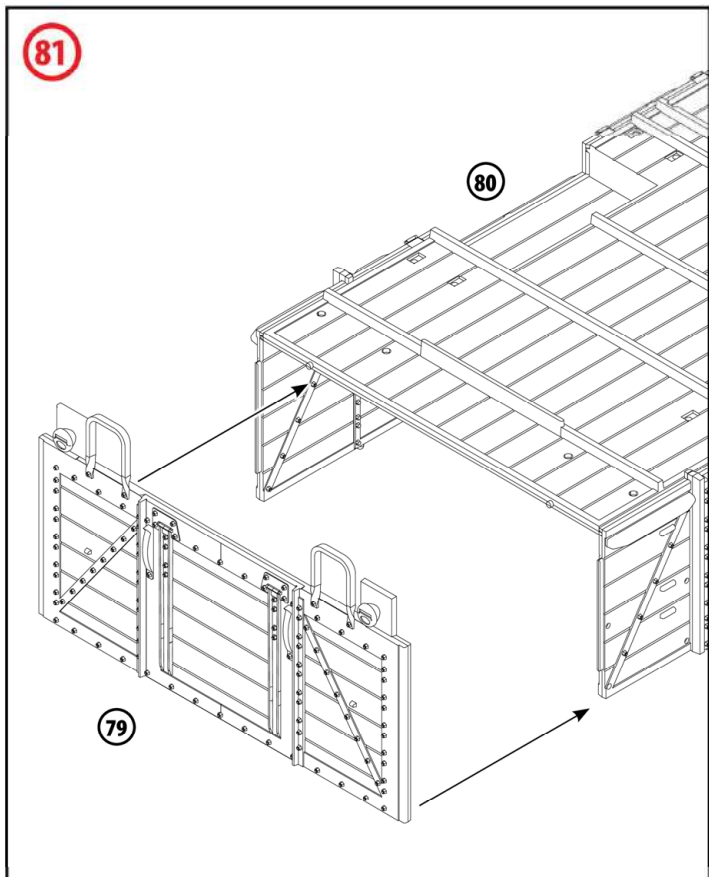

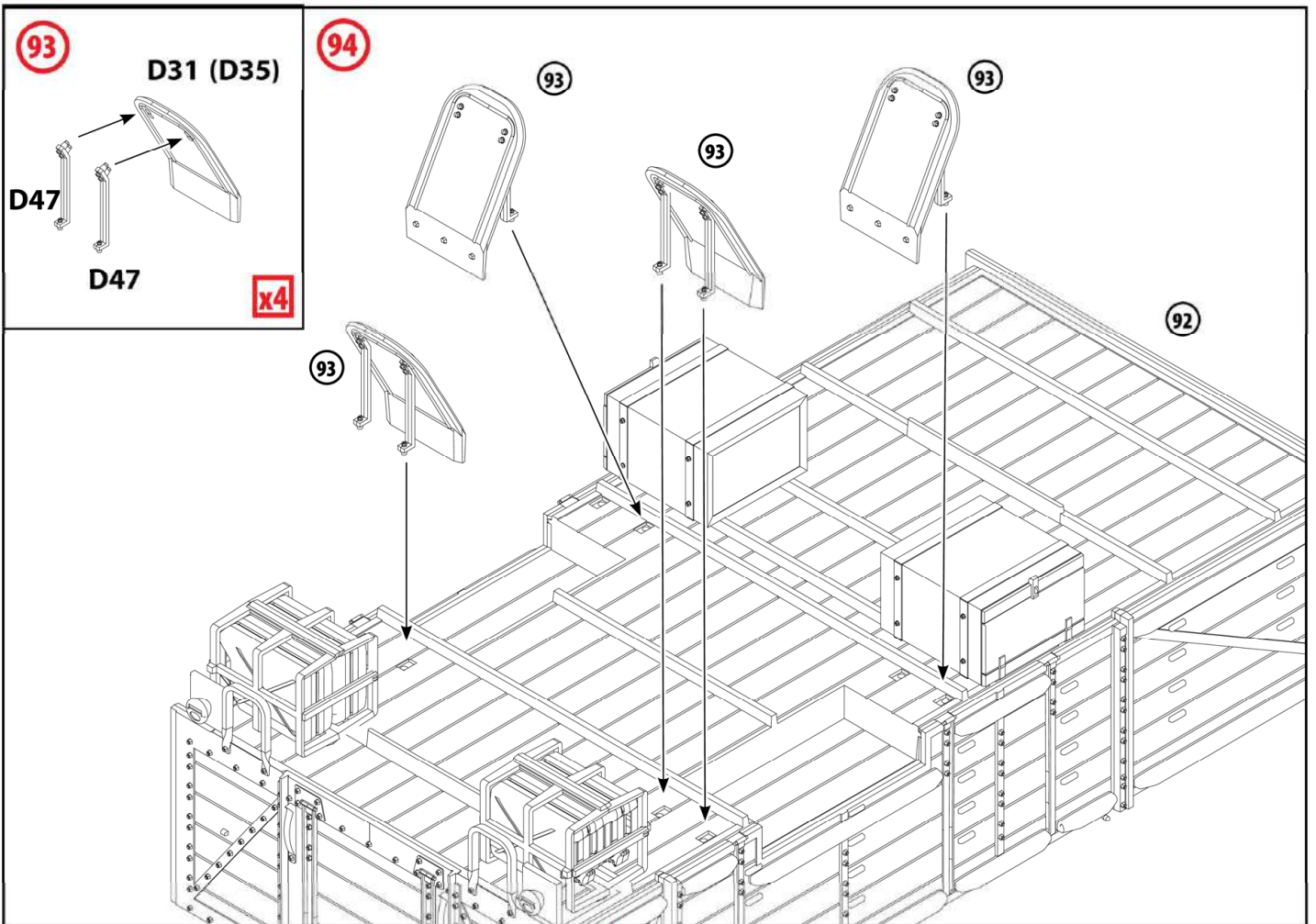
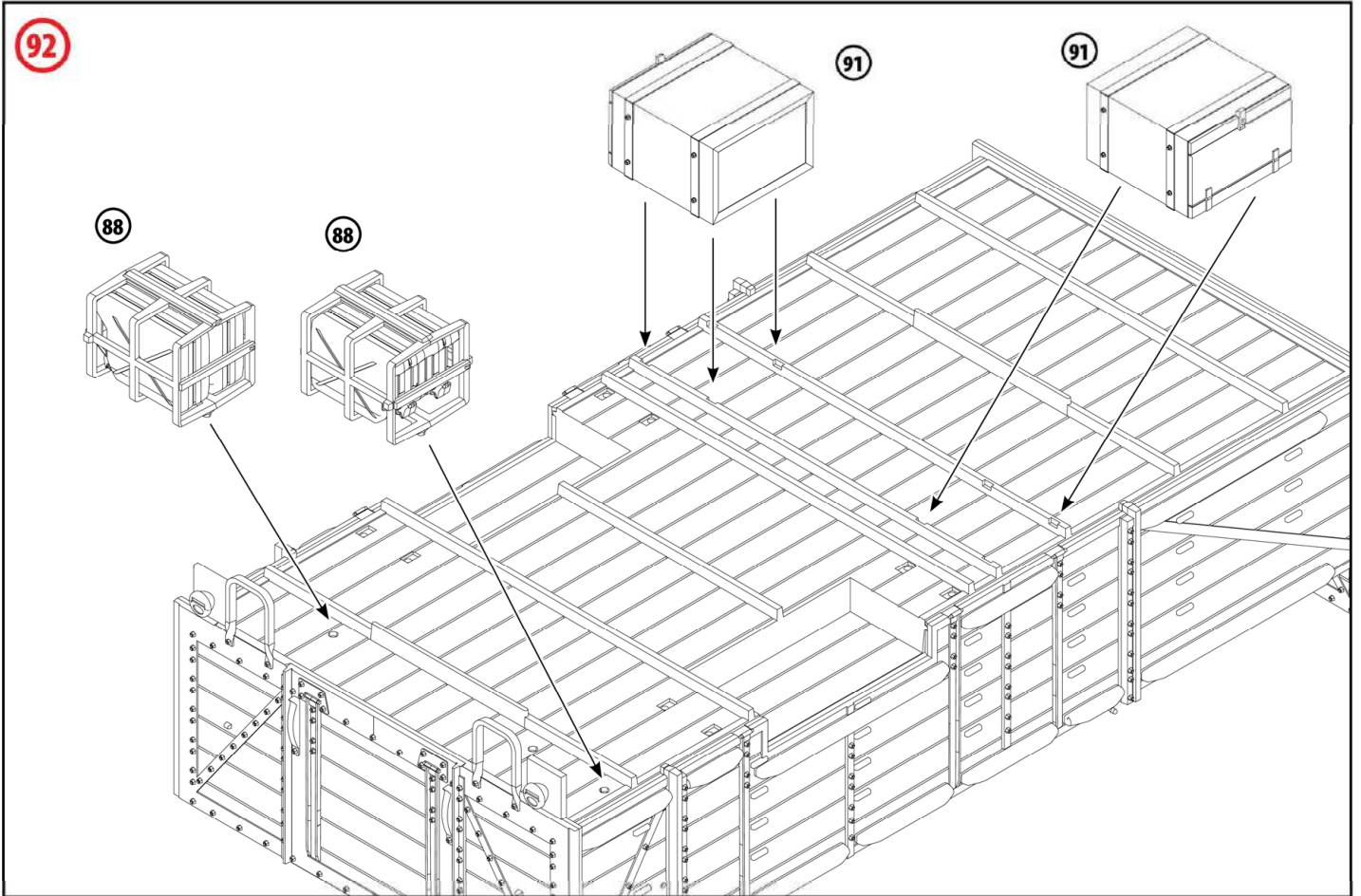

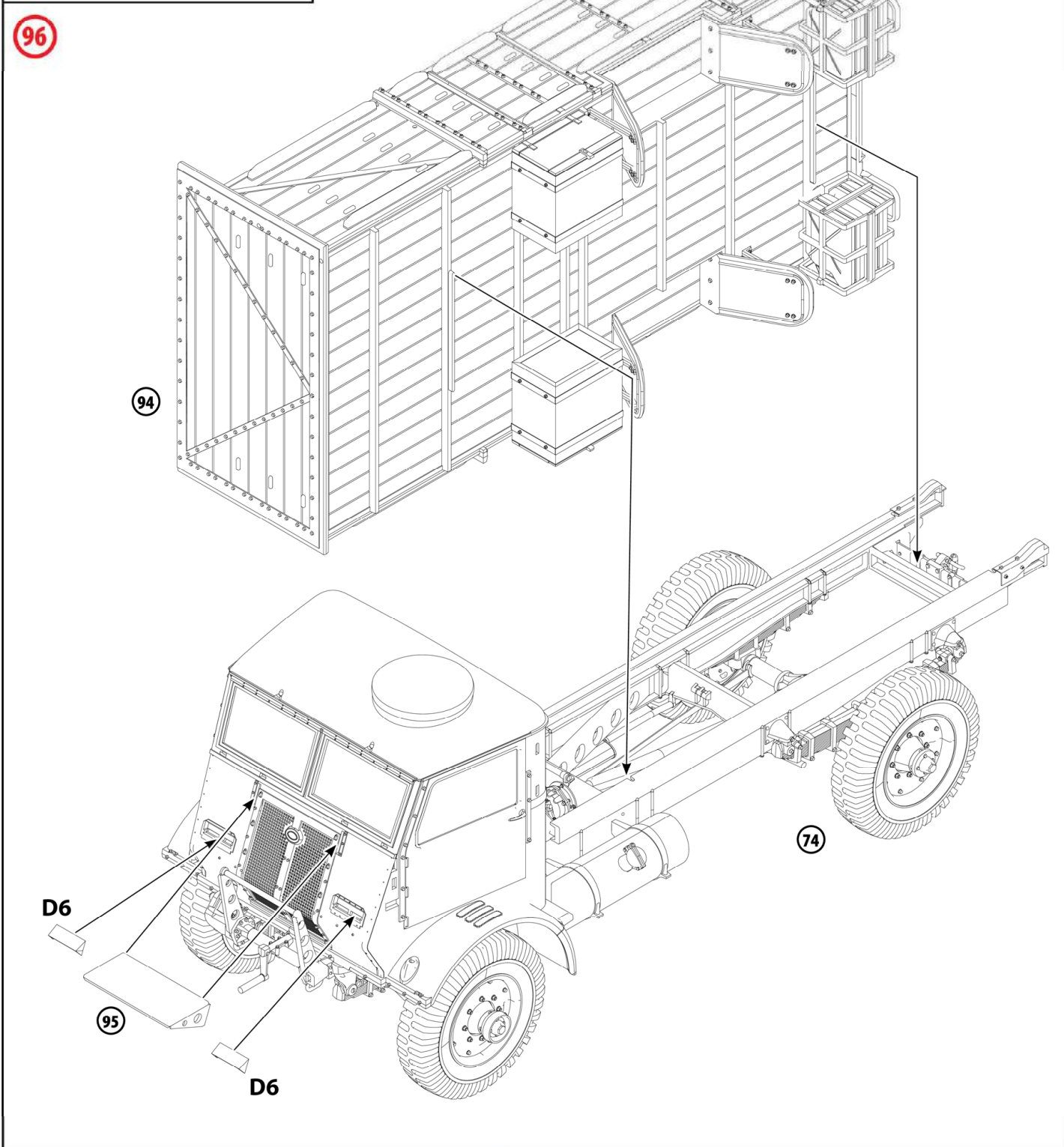
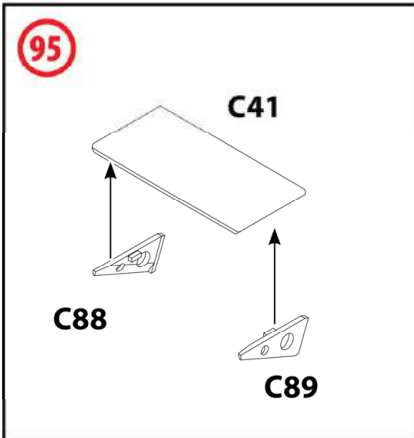

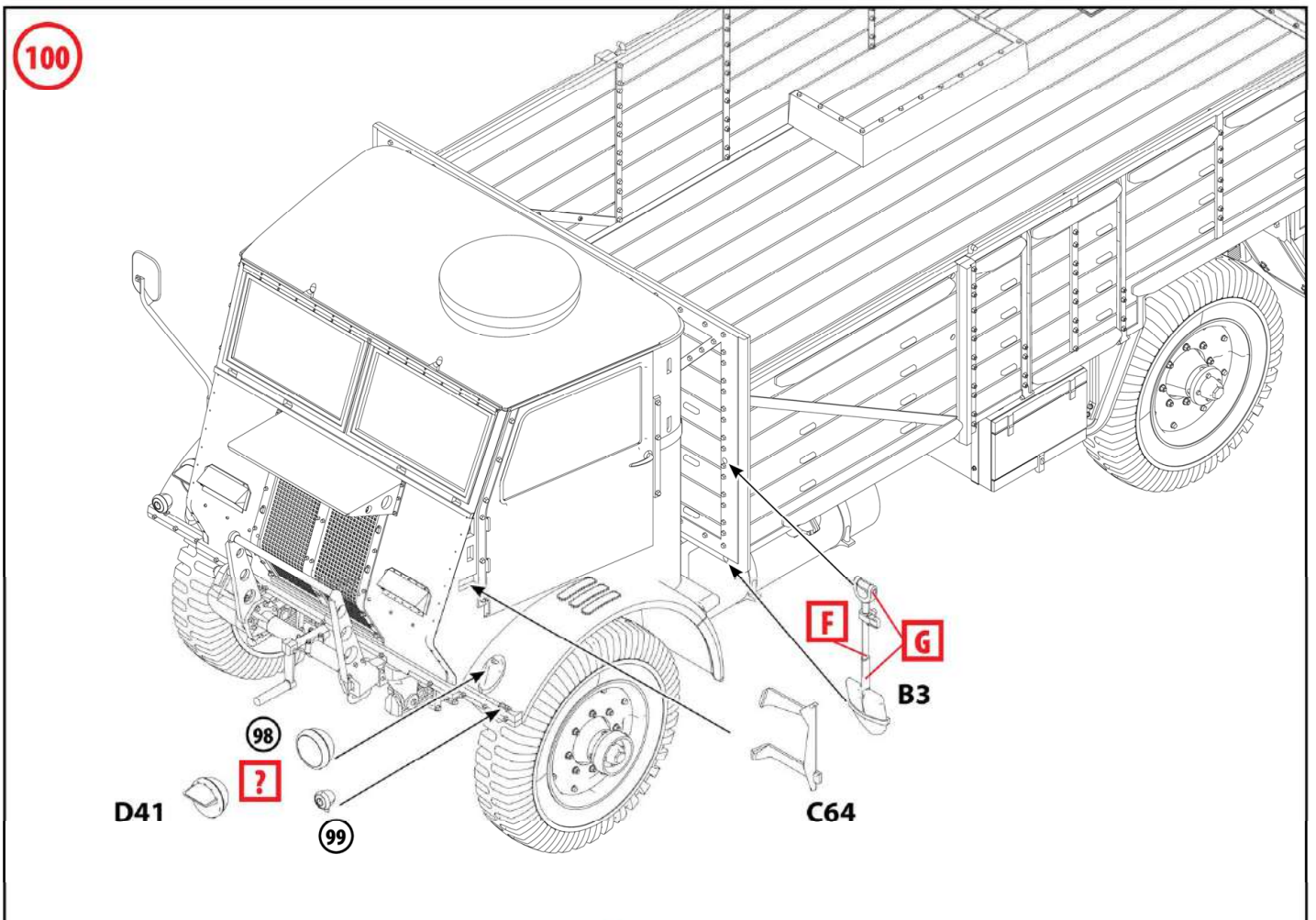
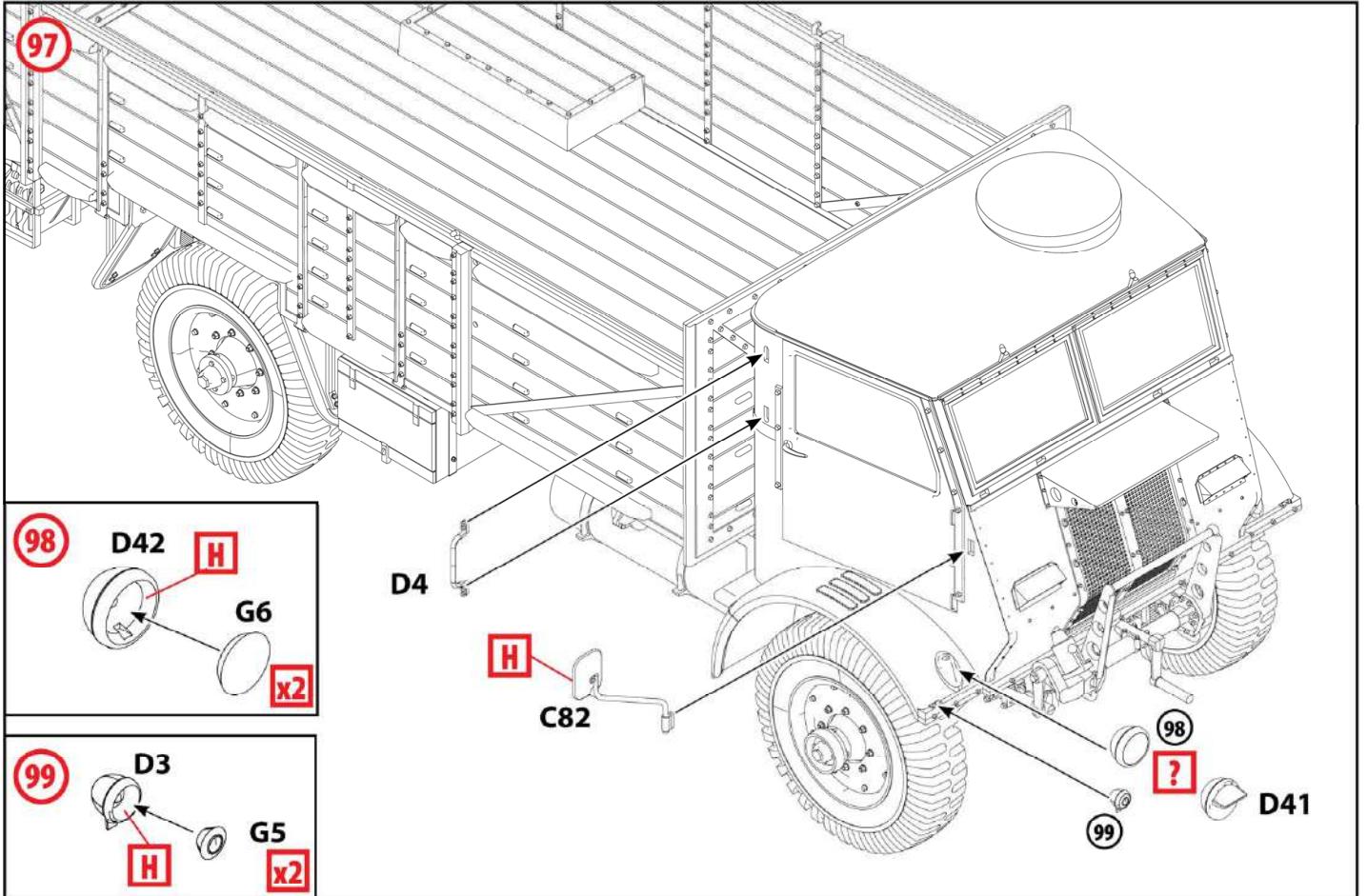

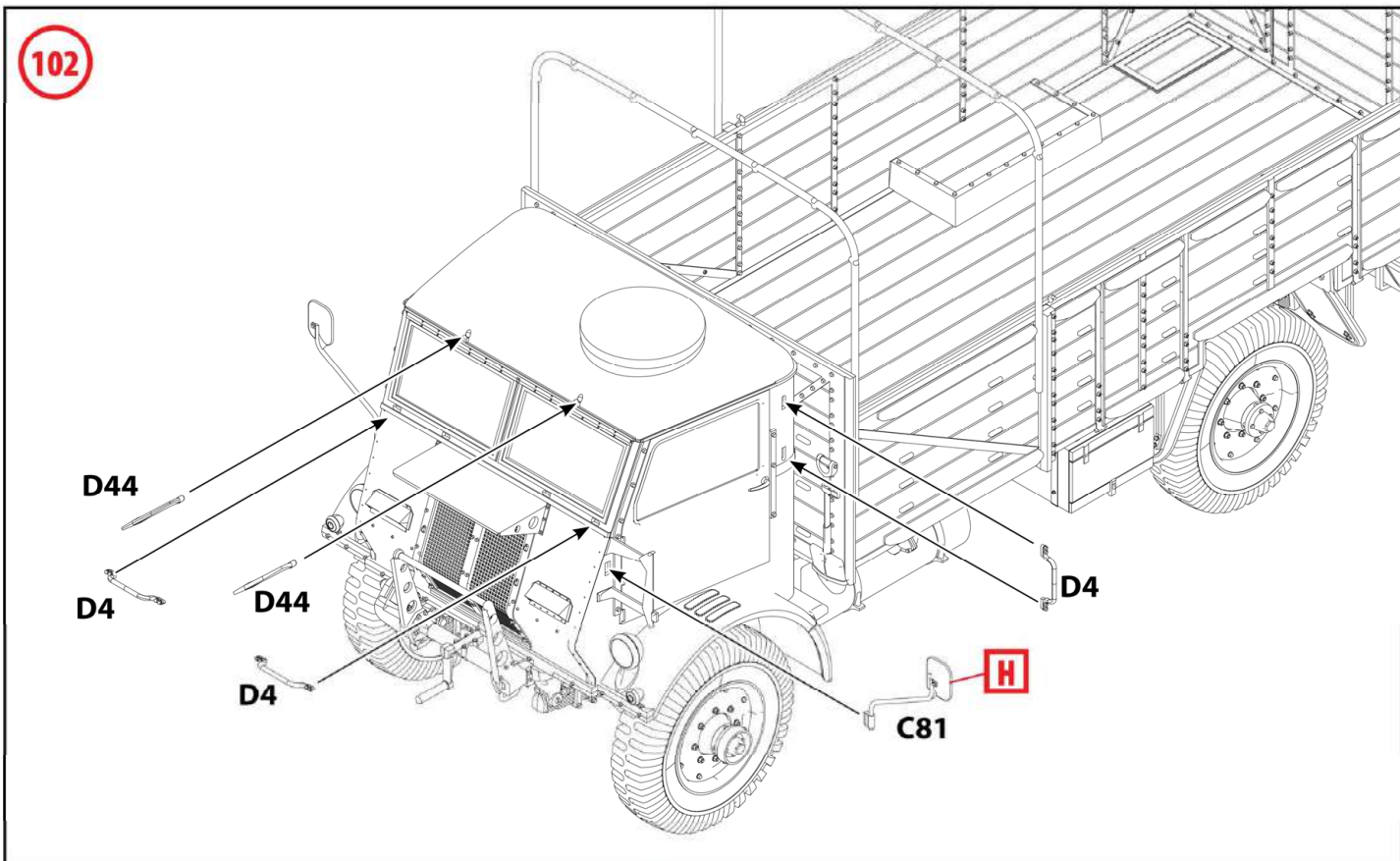
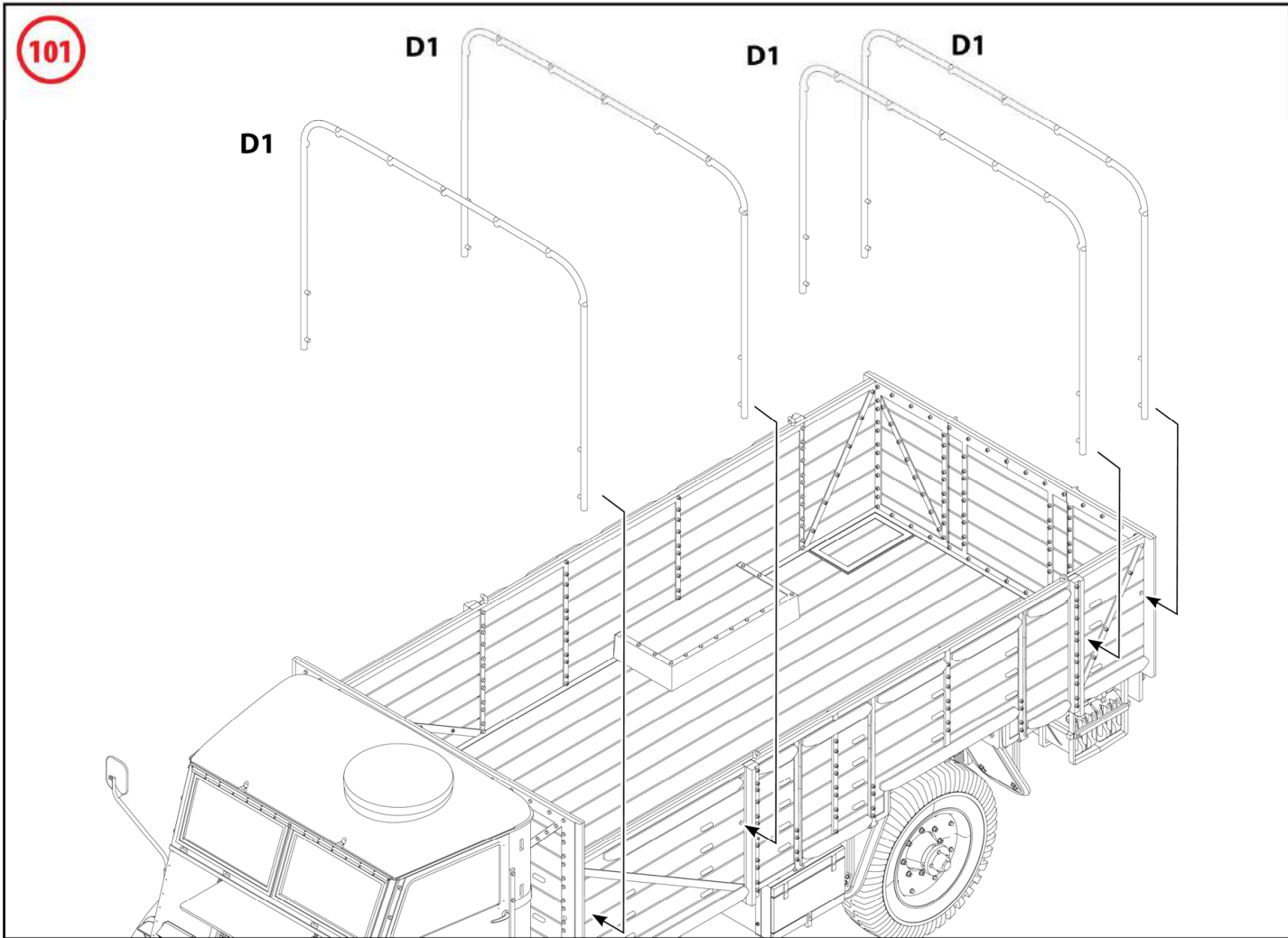

103

D5x7

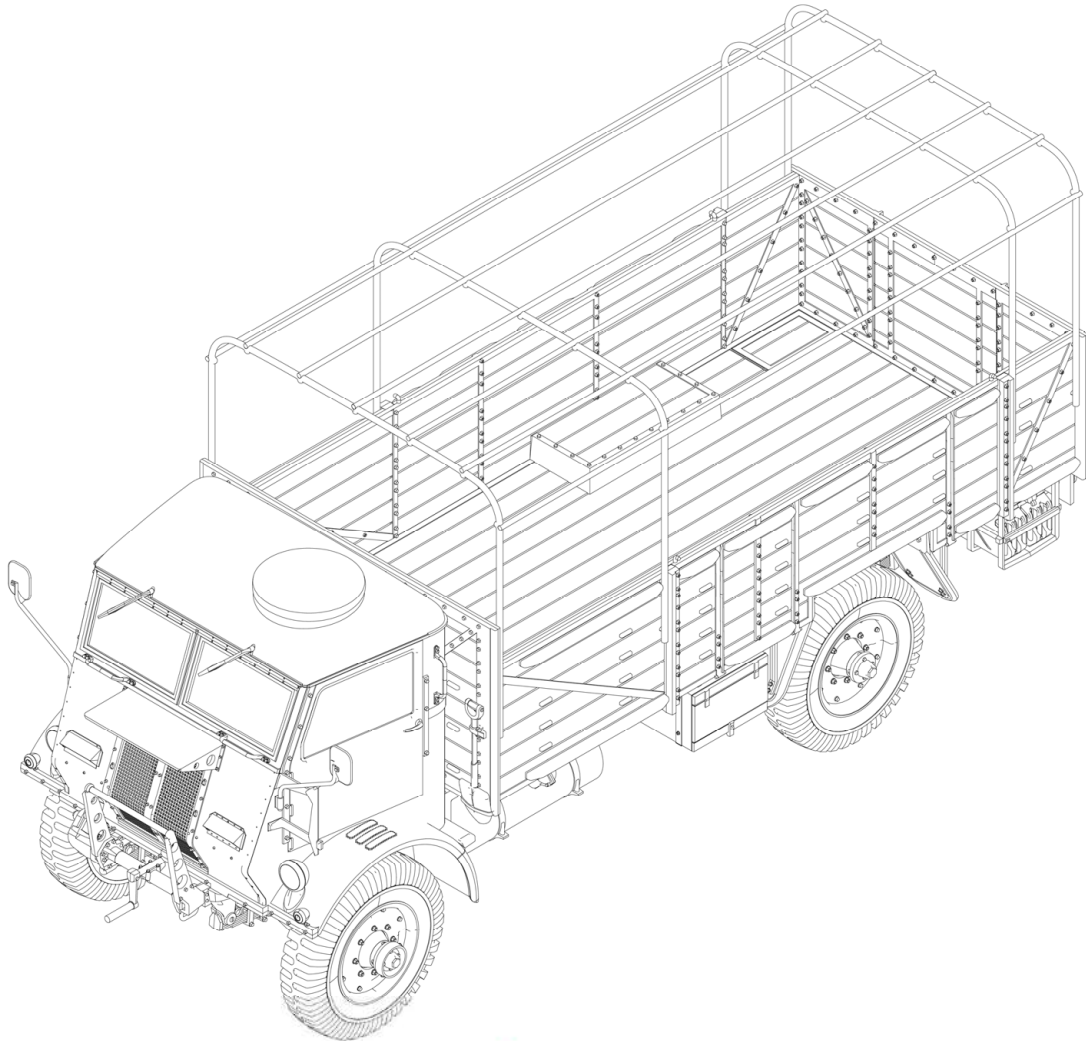
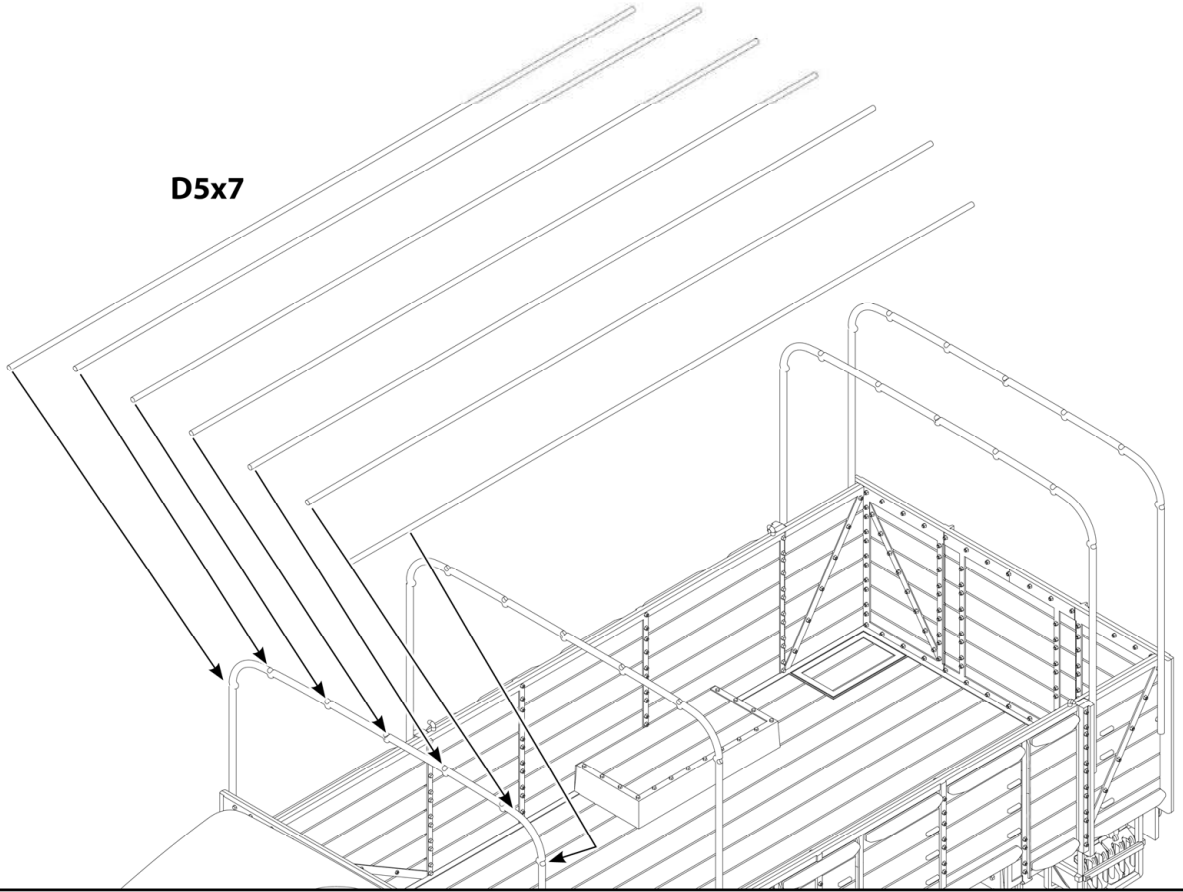

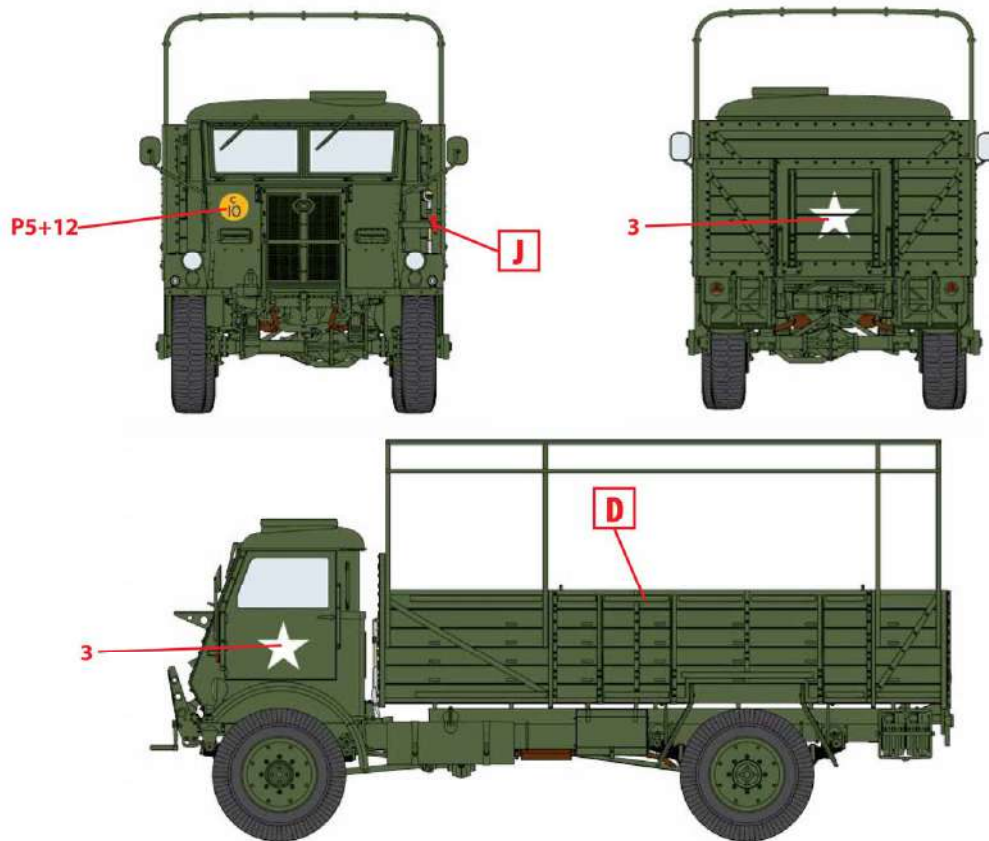

1. W.O.T. 6, Франция, лето 1944 г.
W.O.T. 6, France, Summer 1944

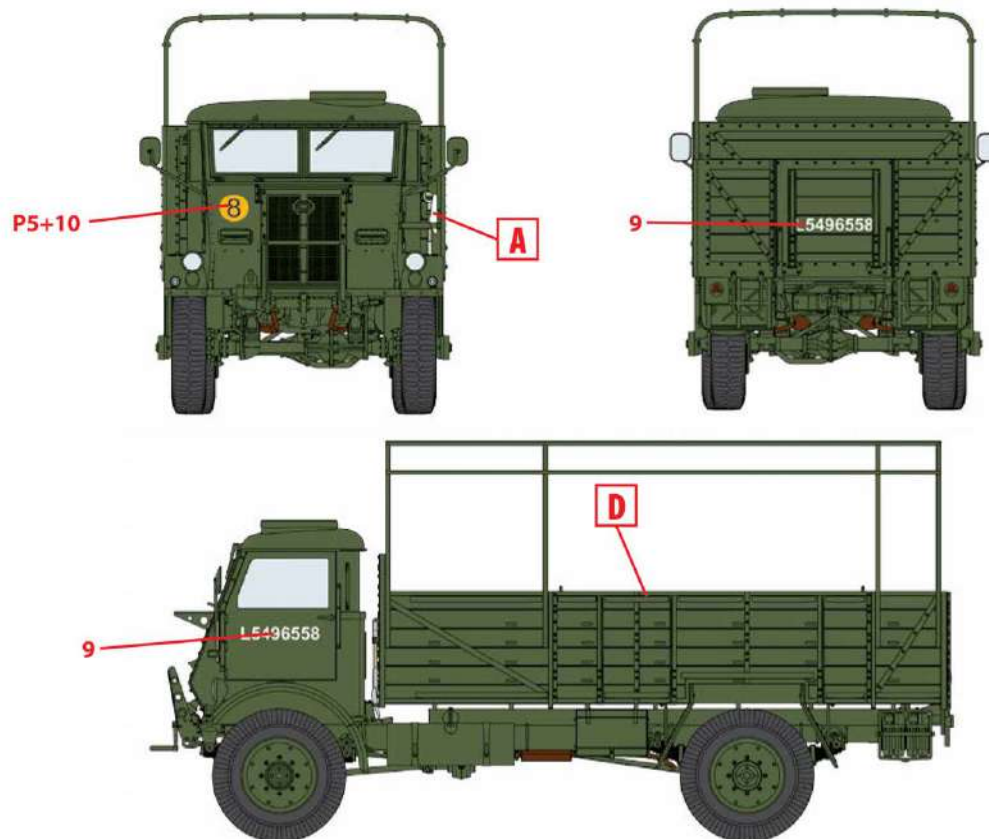

2. W.O.T. 6, Германия, май 1945 г.
W.O.T. 6, Germany, May 1945

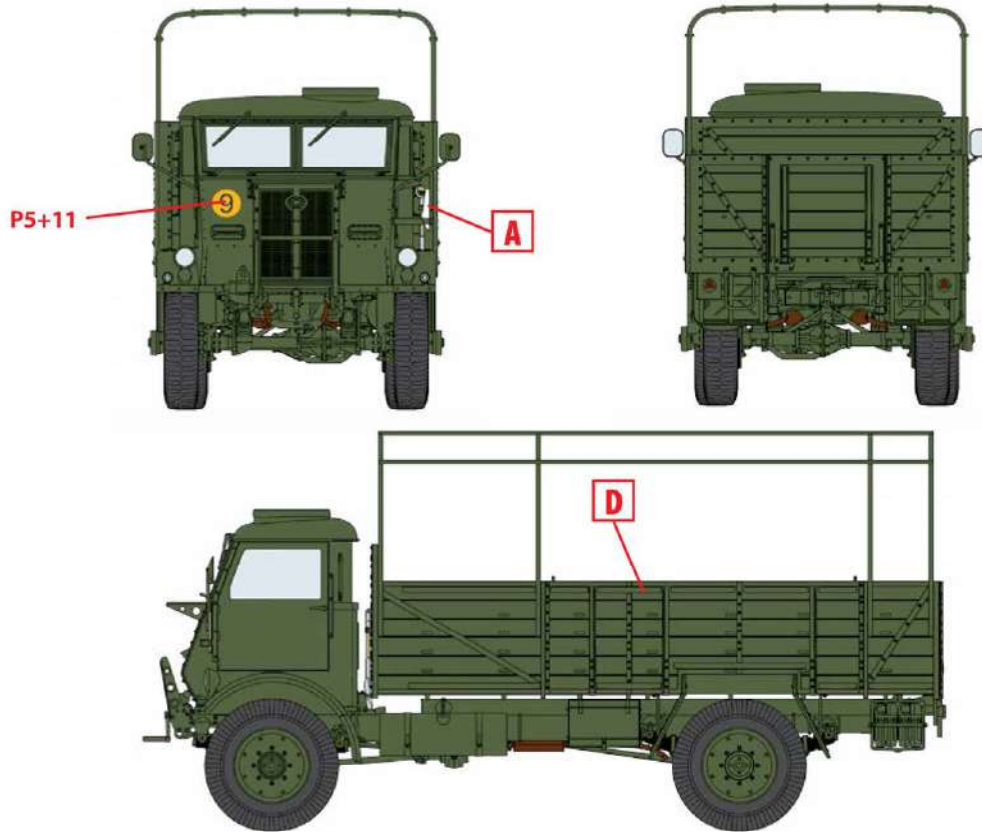

3. W.O.T. 6, Великобритания, лето 1945 г.
W.O.T. 6, Great Britain, Summer 1945

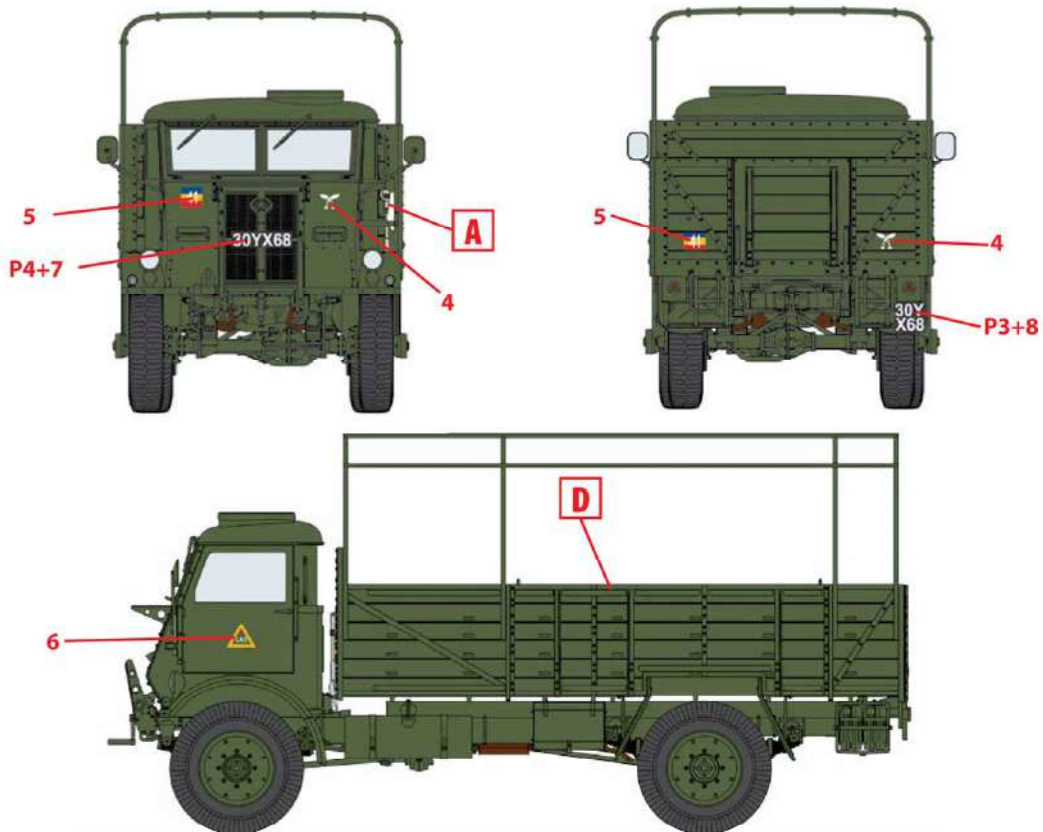

4. W.O.T. 6, Малайя, лето 1945 г.
W.O.T. 6, Malaya, Summer 1945

ООО ICM Холдинг
ул. Бориспольская 9, строение 64,
02099, Киев, Украина
Тел./факс: +38(044) 369 54 12
E-mail: export@icm.com.ua



ICM Holding
Borispolskaya, 9, build. 64,
02099, Kiev, Ukraine
Tel./Fax: +38(044) 369 54 12
E-mail: export@icm.com.ua



Модель W.O.T. 8

Британский грузовой автомобиль II МВ

Одним из наиболее крупных поставщиков грузовых автомобилей для вооруженных сил Великобритании был британский филиал Форд Мотор Компани в Дагенхеме. Грузовики W.O.T. 8 4x4 грузоподъемностью 1,5 т строились в 1941-1942 г. и применялись в Северной Африке, Италии и Северо-Западной Европе между 1942 и 1945 годами. Они состояли на службе и после войны.

Всего было произведено около 2500 грузовиков W.O.T. 8.

Технические характеристики автомобиля W.O.T. 8

Грузоподъемность, т.....	1.5
Длина, мм.....	5220
Ширина, мм.....	2320
Высота, мм.....	2875
База, мм.....	3100
Двигатель.....	«Форд» V8, 3,62 л, 85 л.с.
Максимальная скорость, км/ч.....	75

ВНИМАНИЕ!

Перед сборкой внимательно прочитайте руководство по монтажу. Каждая деталь пронумерована. Соблюдать последовательность монтажа. Необходимые рабочие инструменты: нож и напильник для зачистки деталей; резиновая лента, клейкая лента и зажимы для сушки белья для прижимания склеиваемых деталей. Детали из пластика очистить в растворе мягкого моющего средства и высушить на воздухе для того, чтобы краска и переводные картинки лучше прилипали. Перед приклеиванием проверить, подходят ли детали; клей наносить экономно. Хром и краску удалить с поверхностей склеивания. Небольшие детали покрасить перед тем, как они будут удалены из рамок. Краску необходимо хорошо просушить, только после этого продолжать сборку. Каждую соответствующую переводную картинку отдельно вырезать и примерно на 20 секунд окунуть в теплую воду. На обозначенном месте картинку отделить от бумаги и прижать промокающей бумагой.

Model W.O.T. 8

WWII British Truck

One of the largest supplier of trucks to the British forces was the Ford (UK) Motor Company in Dagenham .

W.O.T. 8 4x4 1,5 t version were built in 1941-1942 and were used in North Africa, Italy and NW Europe between 1942 and 1945, remaining in service after WWII.

There were produced about 2500 W.O.T. 8 trucks.

Technical Specifications of W.O.T. 8 truck

Full load, t.....	1.5
Length, mm.....	5220
Width, mm.....	2320
Height, mm.....	2875
Wheel base, mm.....	3100
Engine.....	Ford V8, 3,62 l, 85 hp
Max. Speed, km/h.....	75

CAUTION!

Read the instructions thoroughly prior to assembly. Each component is numbered. Adhere to specified sequence of assembly. Tools required: knife and file for removal of components from frame; rubber bond, adhesive tape and clothes pegs for clamping components together after applying adhesive. Clean plastic components in a mild detergent solution and allow to air-dry so that paint and transfers adhere better. Prior to applying adhesive, check to see whether the components fit together; apply adhesive sparingly. Remove chrome and paint from the contact surfaces. Paint small components before removing them from the frame. Allow paint to dry well, and only then continue to assemble. Cut out each transfer individually and immerse in warm water for approx. 20 seconds. Slide transfer off paper and into designated position, then press on with blotting paper.

ИСПОЛЬЗУЕМЫЕ КРАСКИ / USED COLORS:

	Revell	Tamiya		
A	105	XF2	Белый, матовый	Flat White
B	107	X1	Черный, глянцевоый	Gloss Black
C	302	X18	Черный, полуматовый	Semigloss Black
D	165	XF58	Оливково-зеленый, мат.	Olive Green
E	186	XF49	Хаки, матовый	Khaki

	Revell	Tamiya		
F	189	XF78	Дерево	Wood
G	191	X32	Сталь	Steel
H	190	X11	Серебристый	Chrome Silver
J	731	X27	Красный, прозрачный	Clear Red
K	183	XF84	Ржавчина	Rust

01 СТАДИЯ СБОРКИ
ASSEMBLY STEP

A ИСПОЛЬЗУЕМАЯ КРАСКА
USED COLOR

✂ ОТРЕЗАТЬ
CUT OFF

? ПРОИЗВОЛЬНЫЙ ВЫБОР
OPTIONAL

03 СБОРОЧНАЯ ЕДИНИЦА
ASSEMBLY UNIT

■ ПРИ СБОРКЕ НЕ ИСПОЛЬЗУЕТСЯ
PARTS NOT FOR USE

↩ СОГНУТЬ
BEND

x2 СДЕЛАТЬ ДВЕ ДЕТАЛИ
MAKE 2 PCS

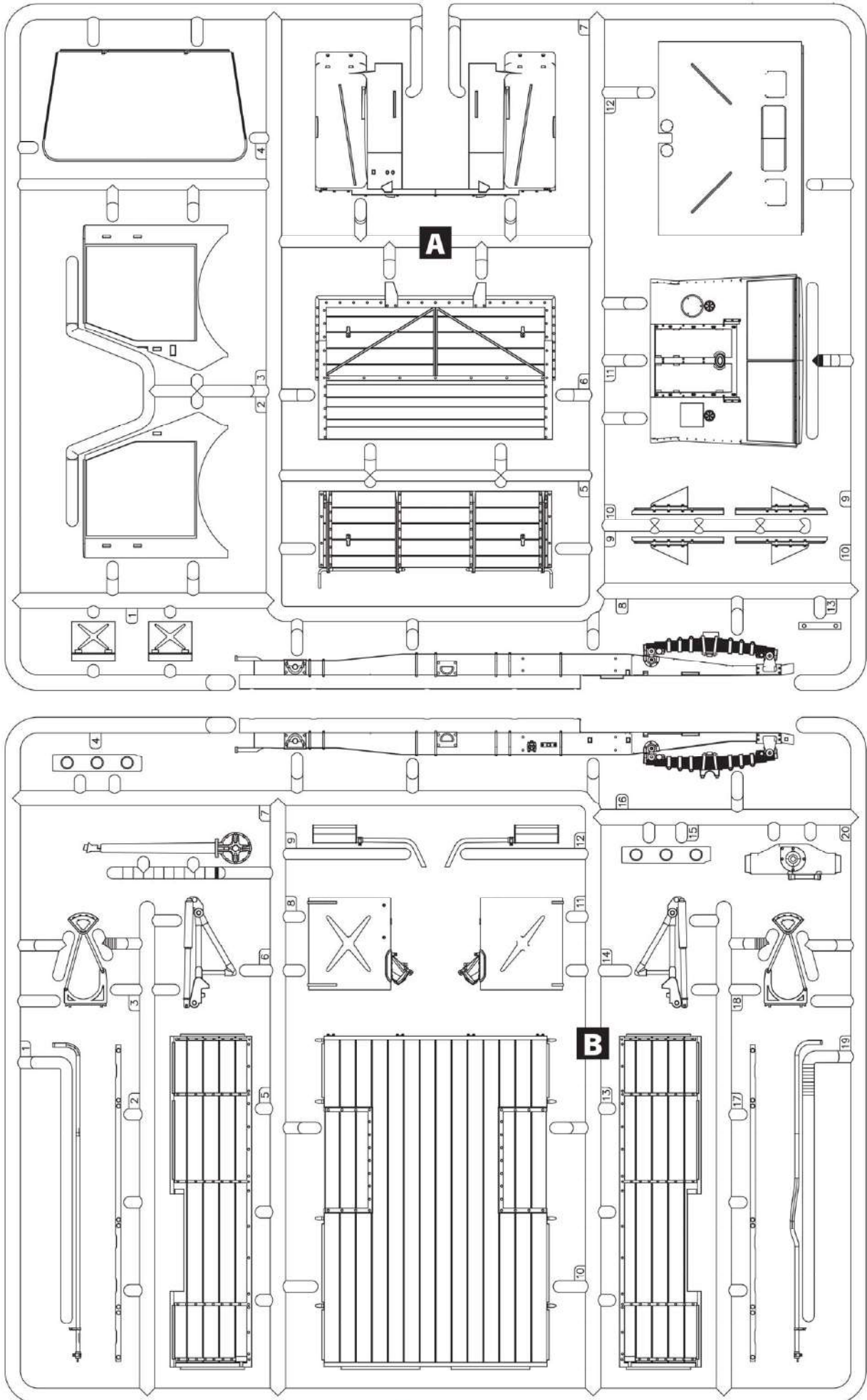

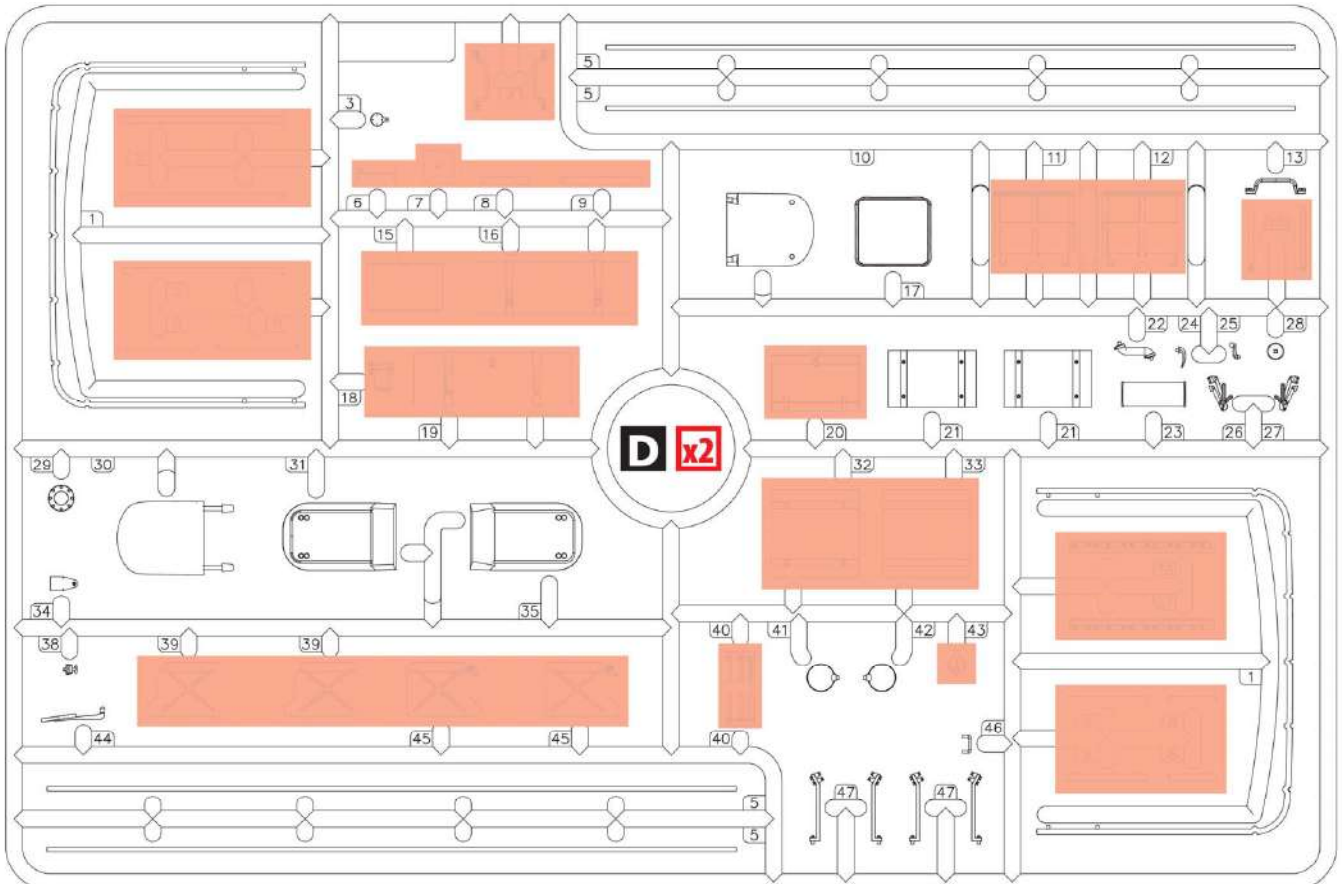
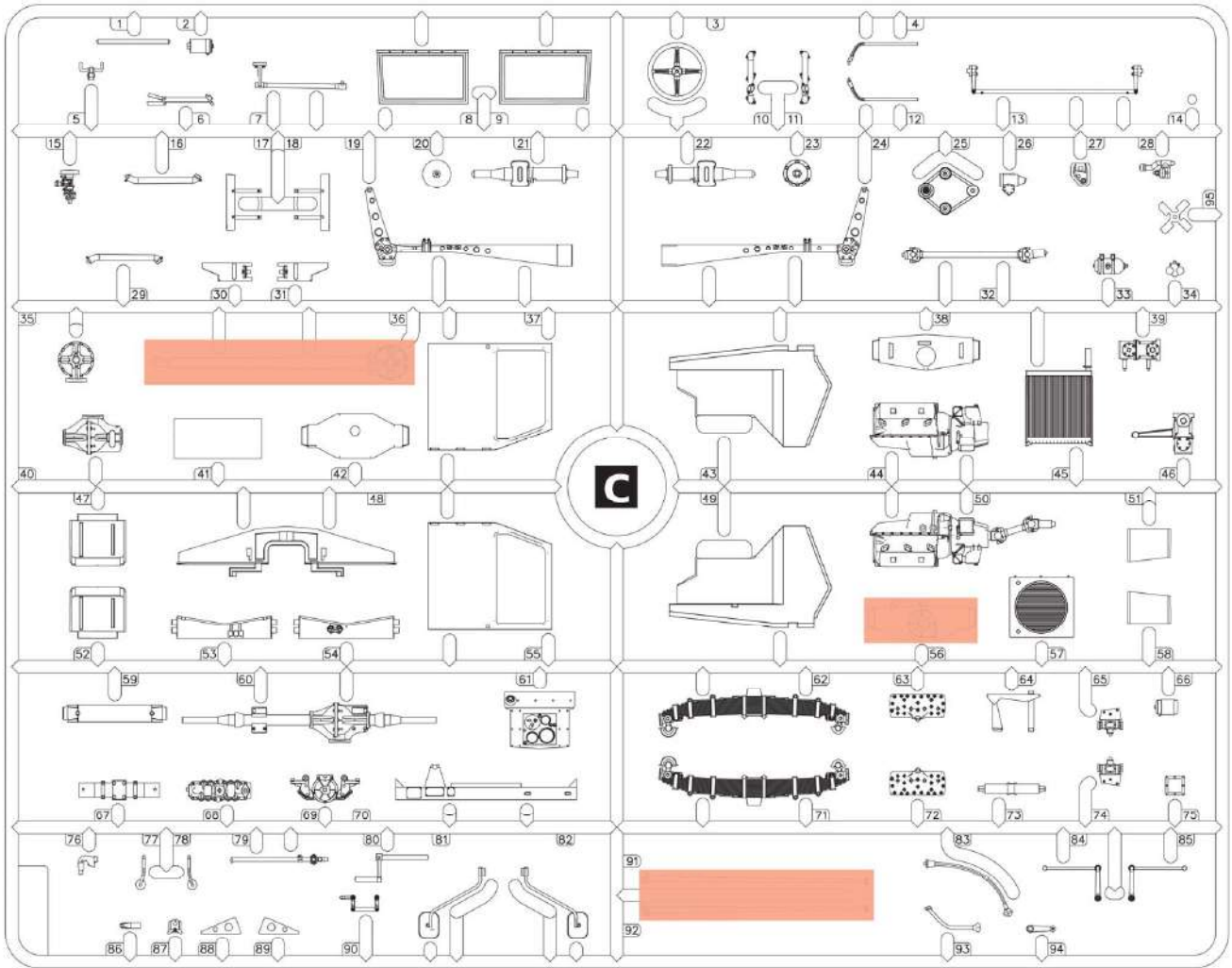

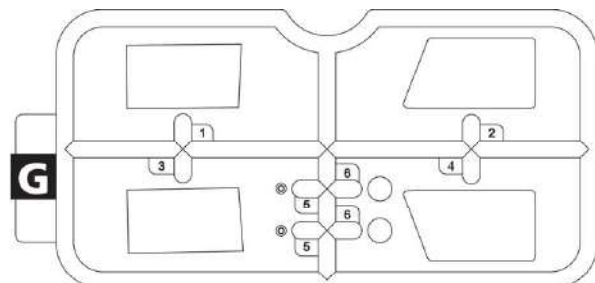
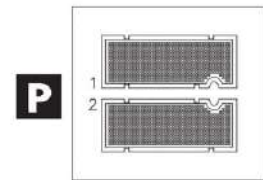
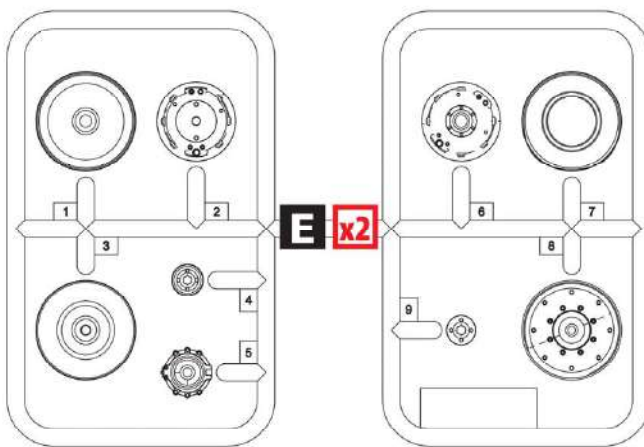
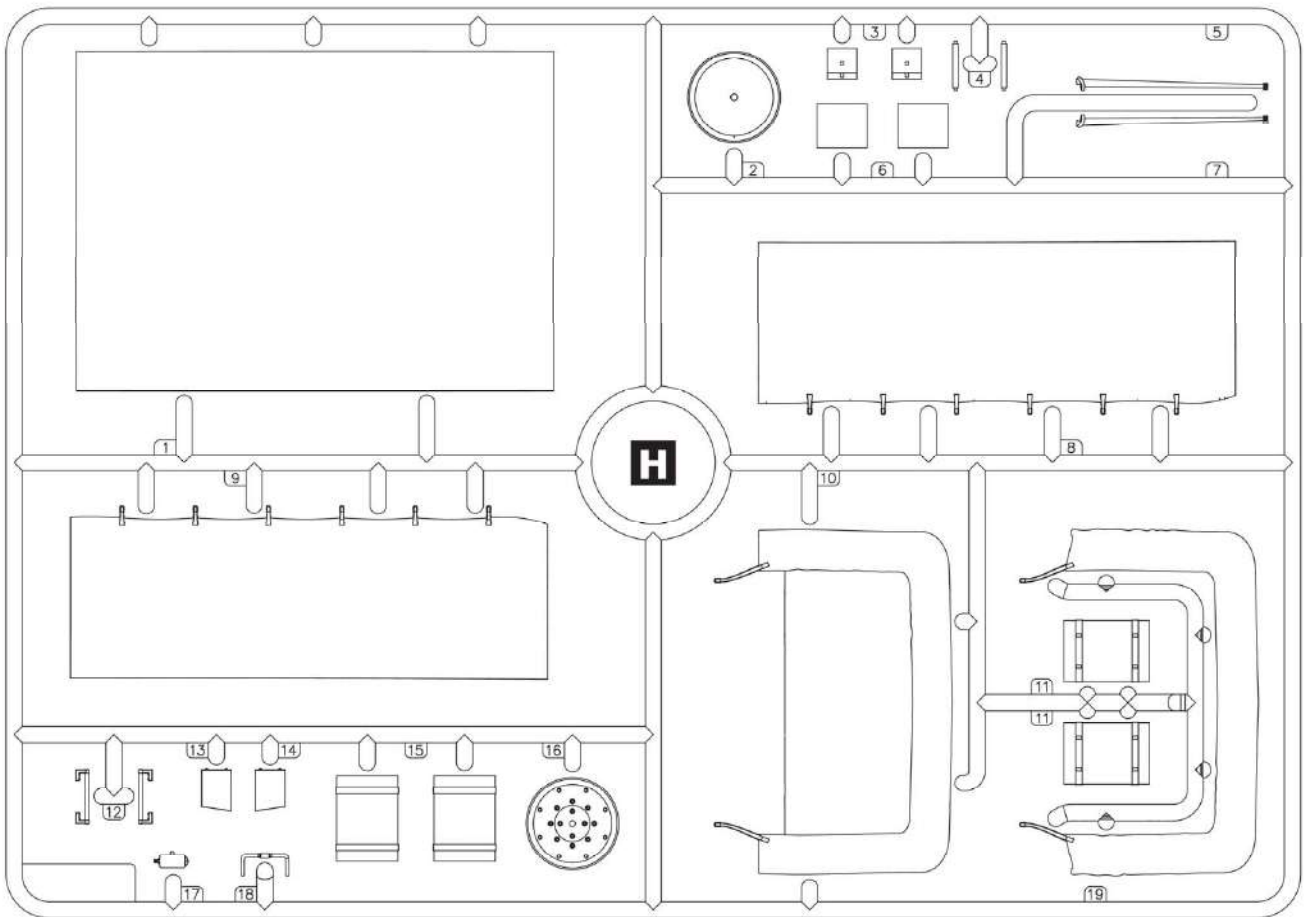

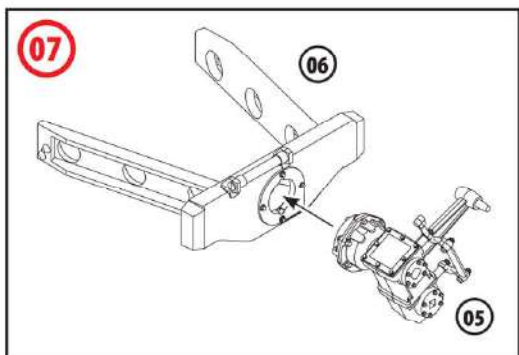
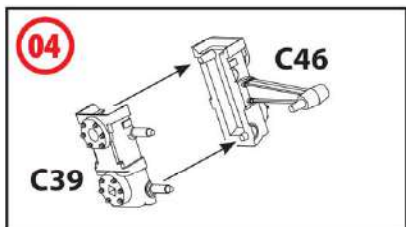
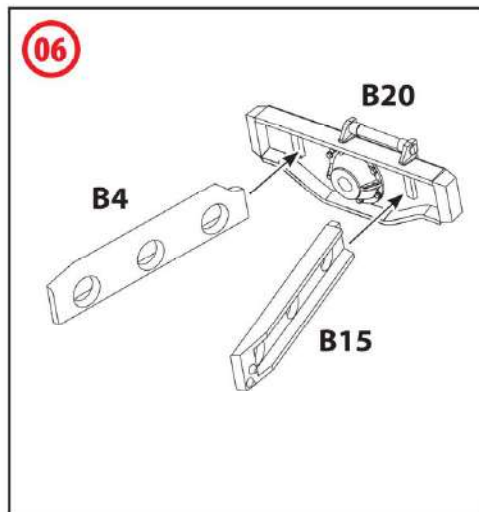
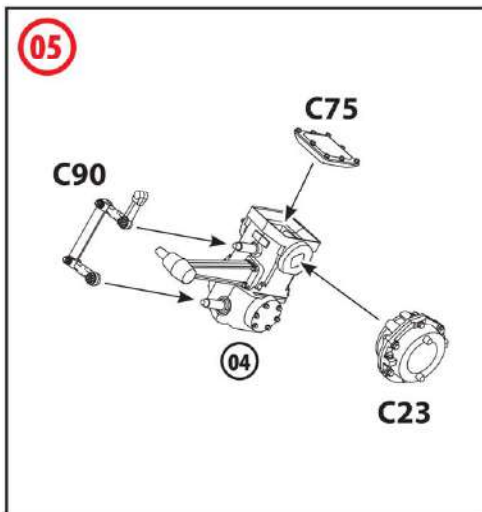
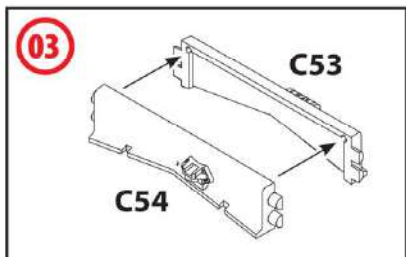
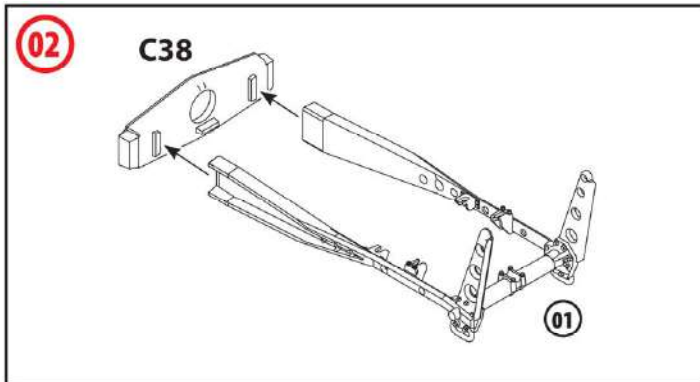
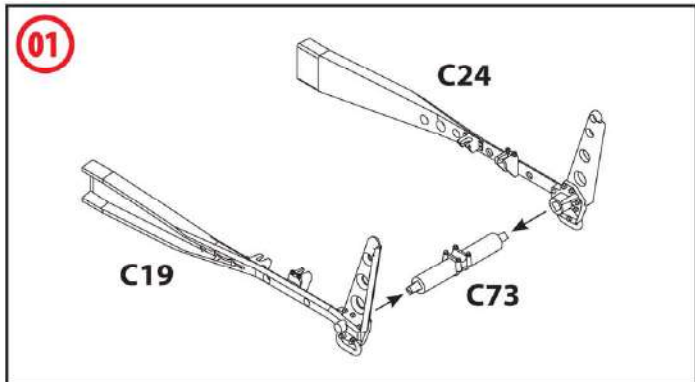

D ВСЕ ДЕТАЛИ ШАССИ, КРОМЕ ОБОЗНАЧЕННЫХ ОТДЕЛЬНО
ALL CHASSIS DETAILS EXCEPT MARKED SEPARATLY

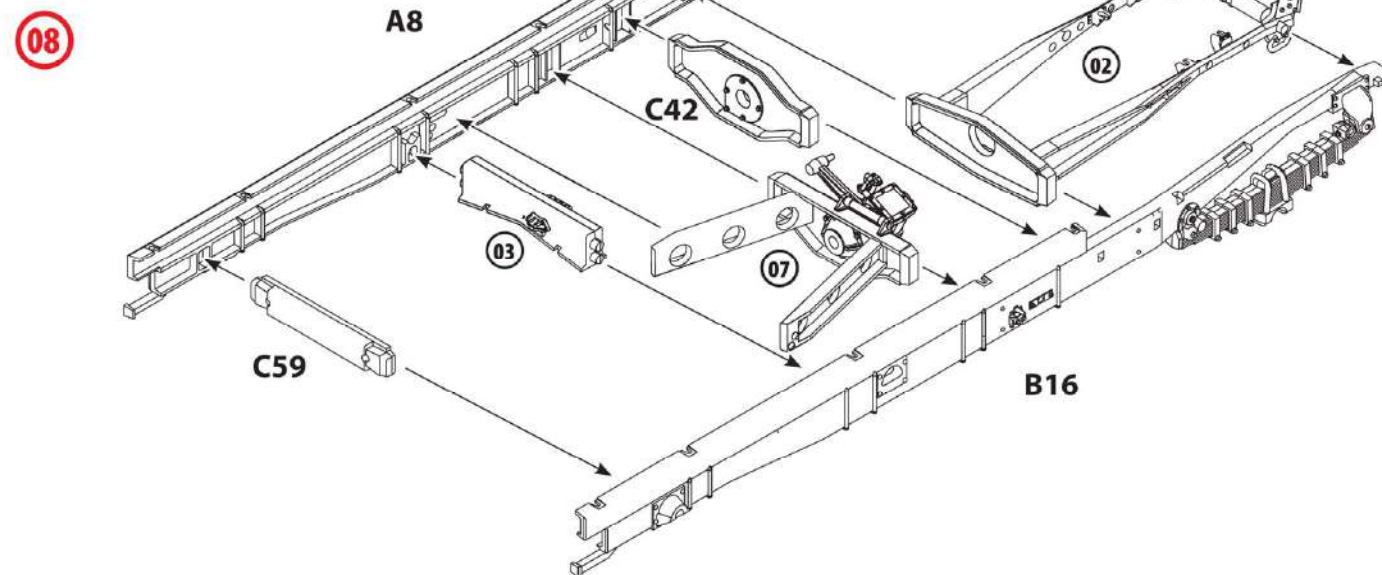

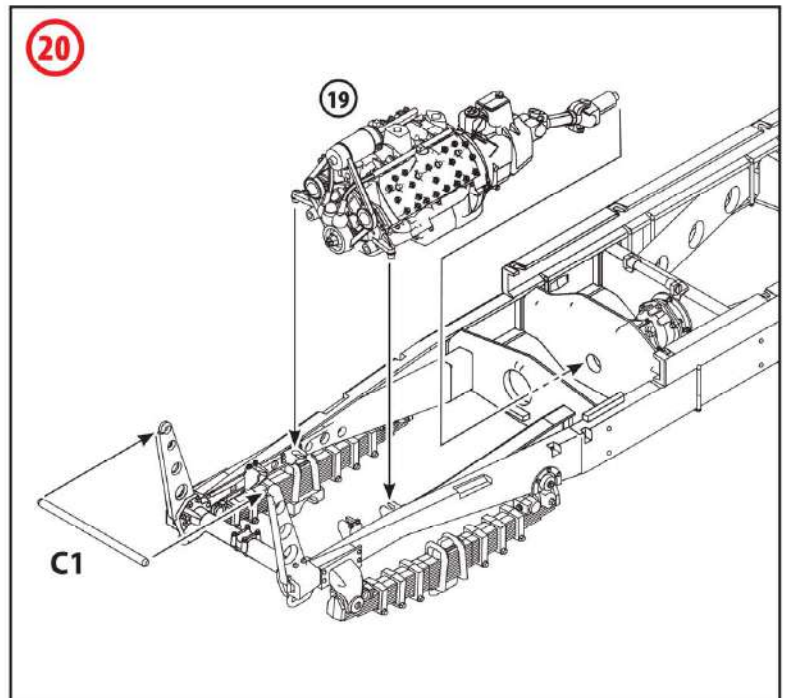
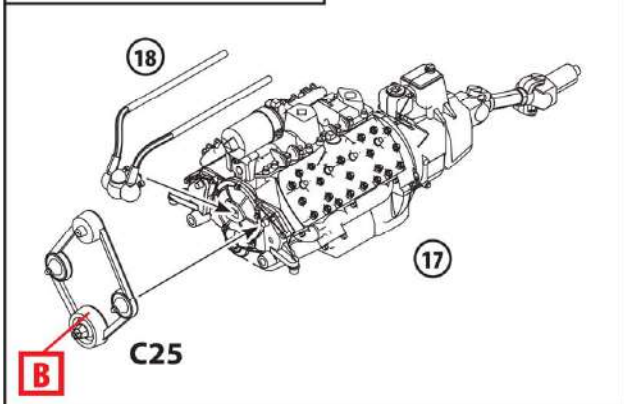
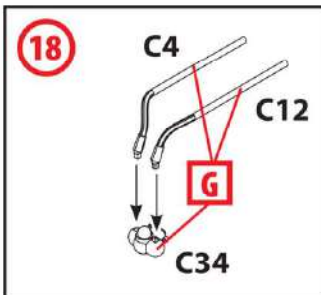
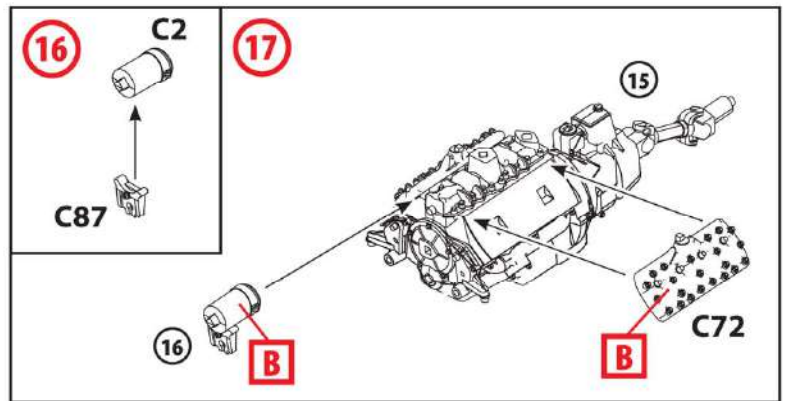
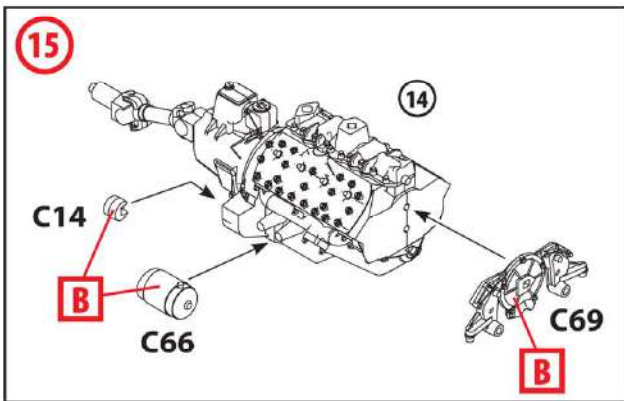
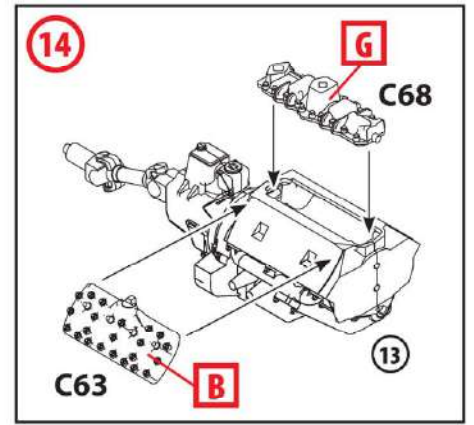
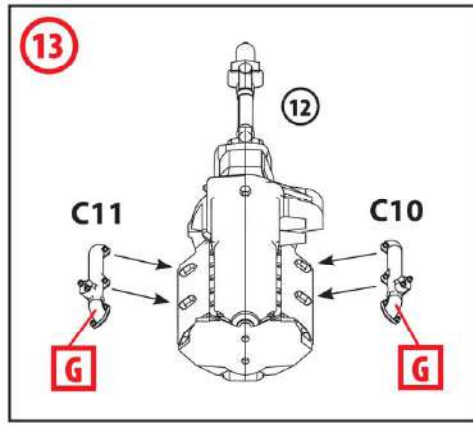
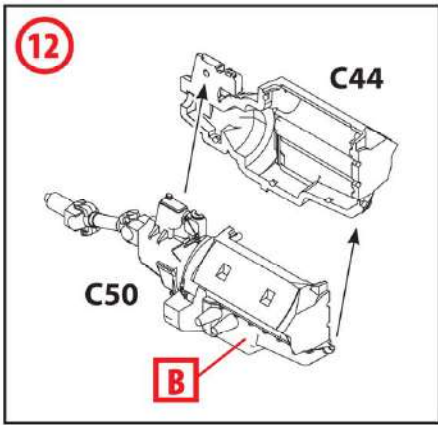
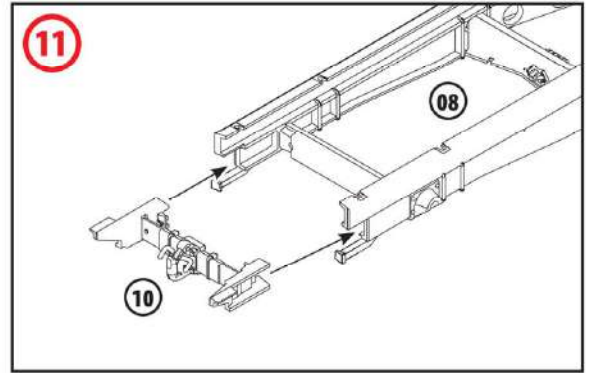
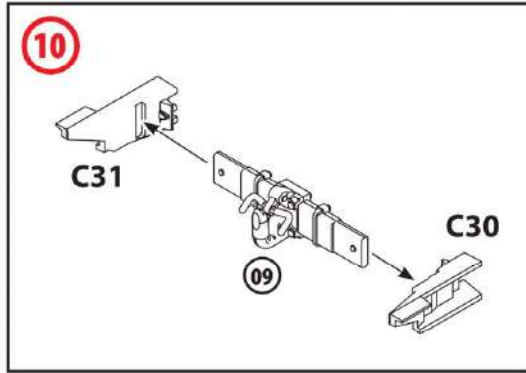
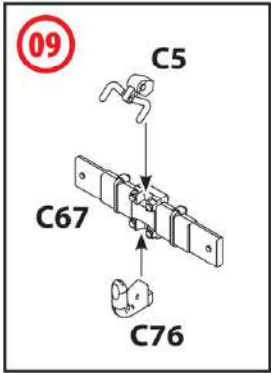

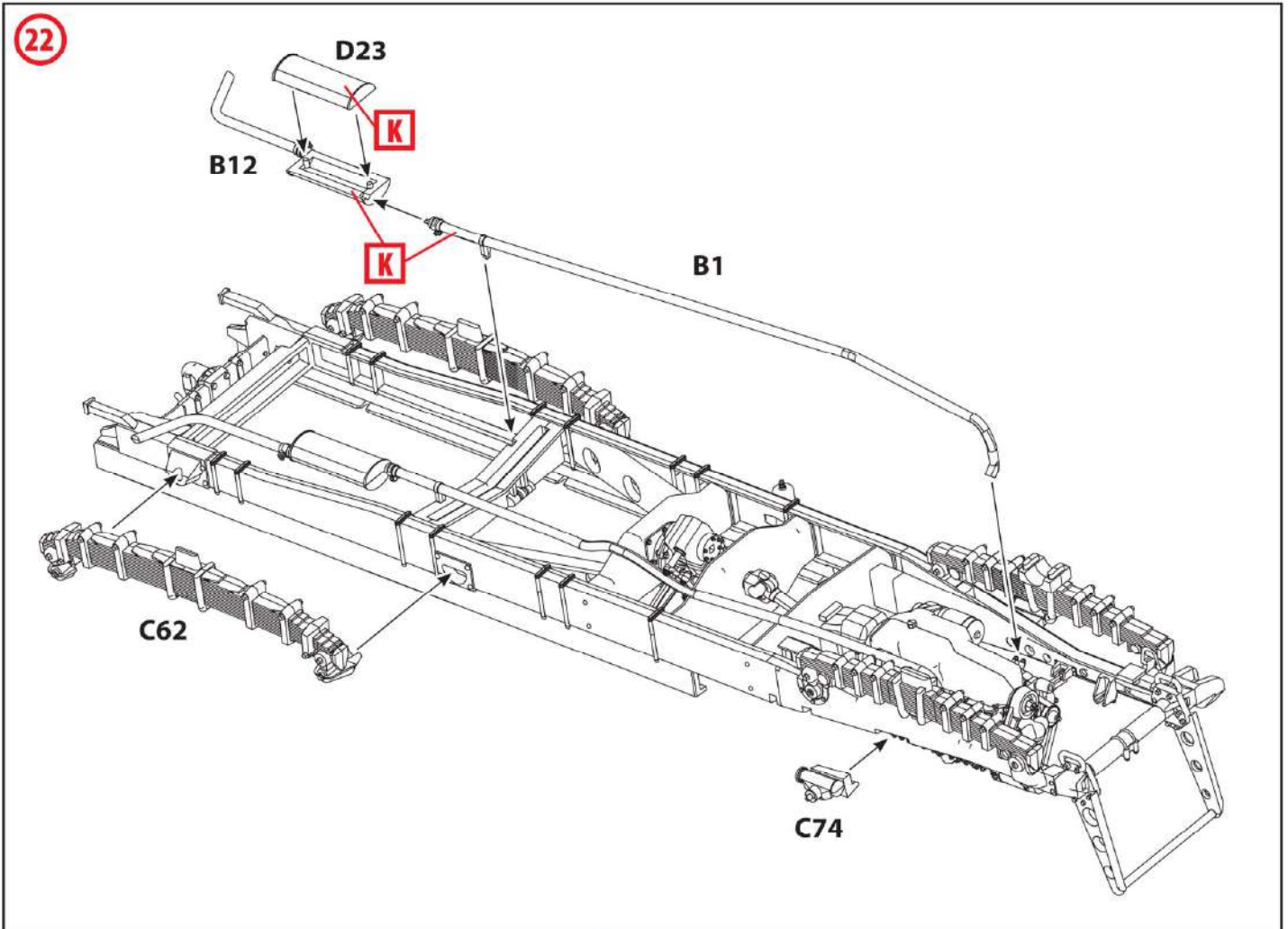
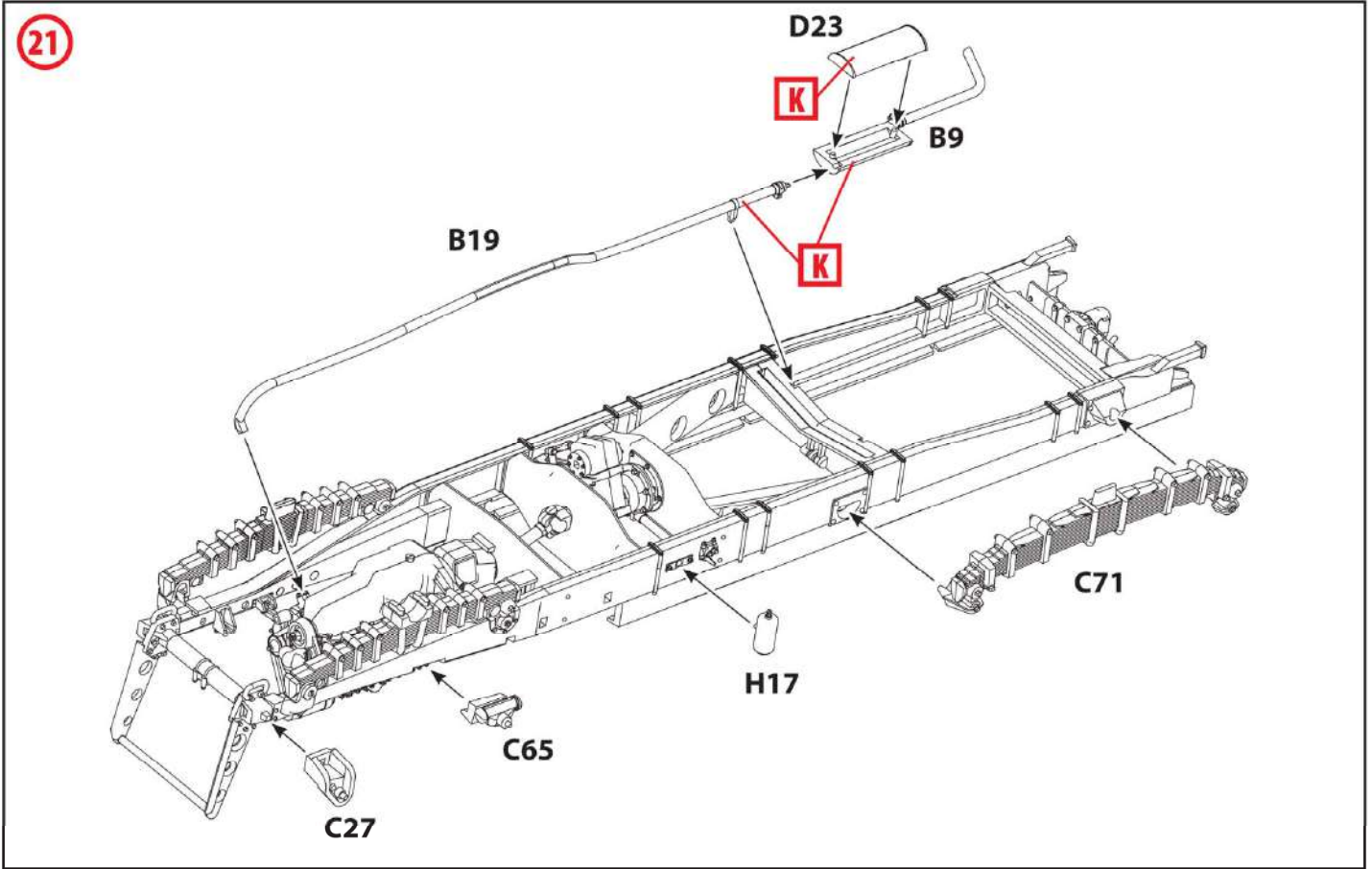

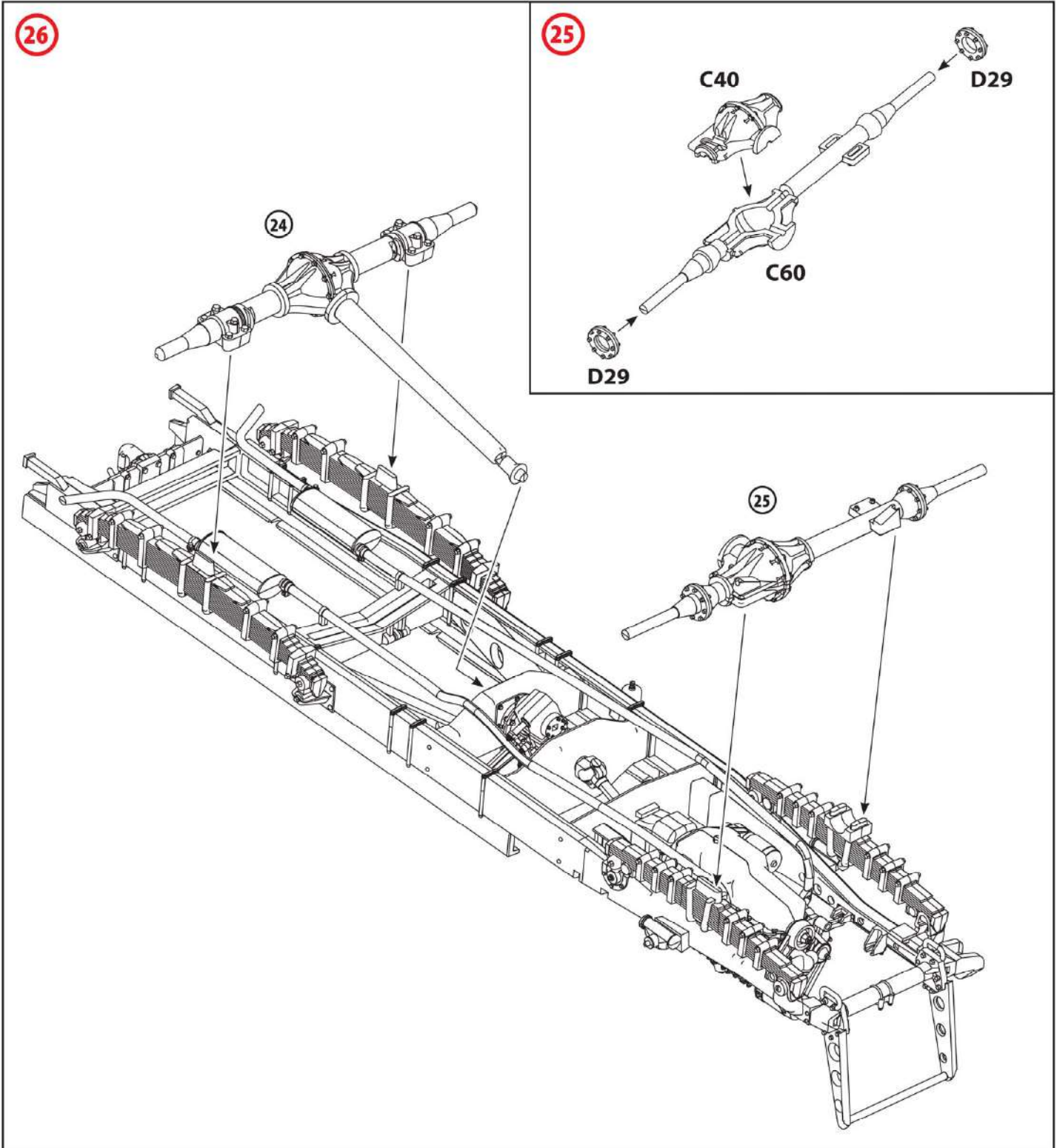
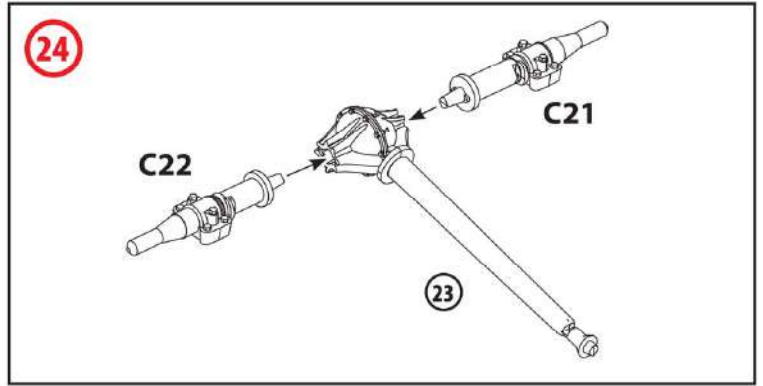
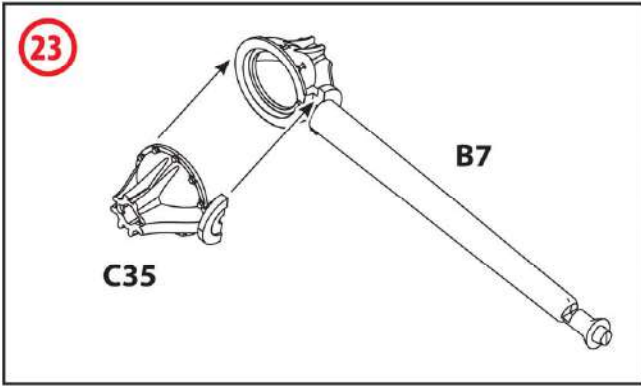

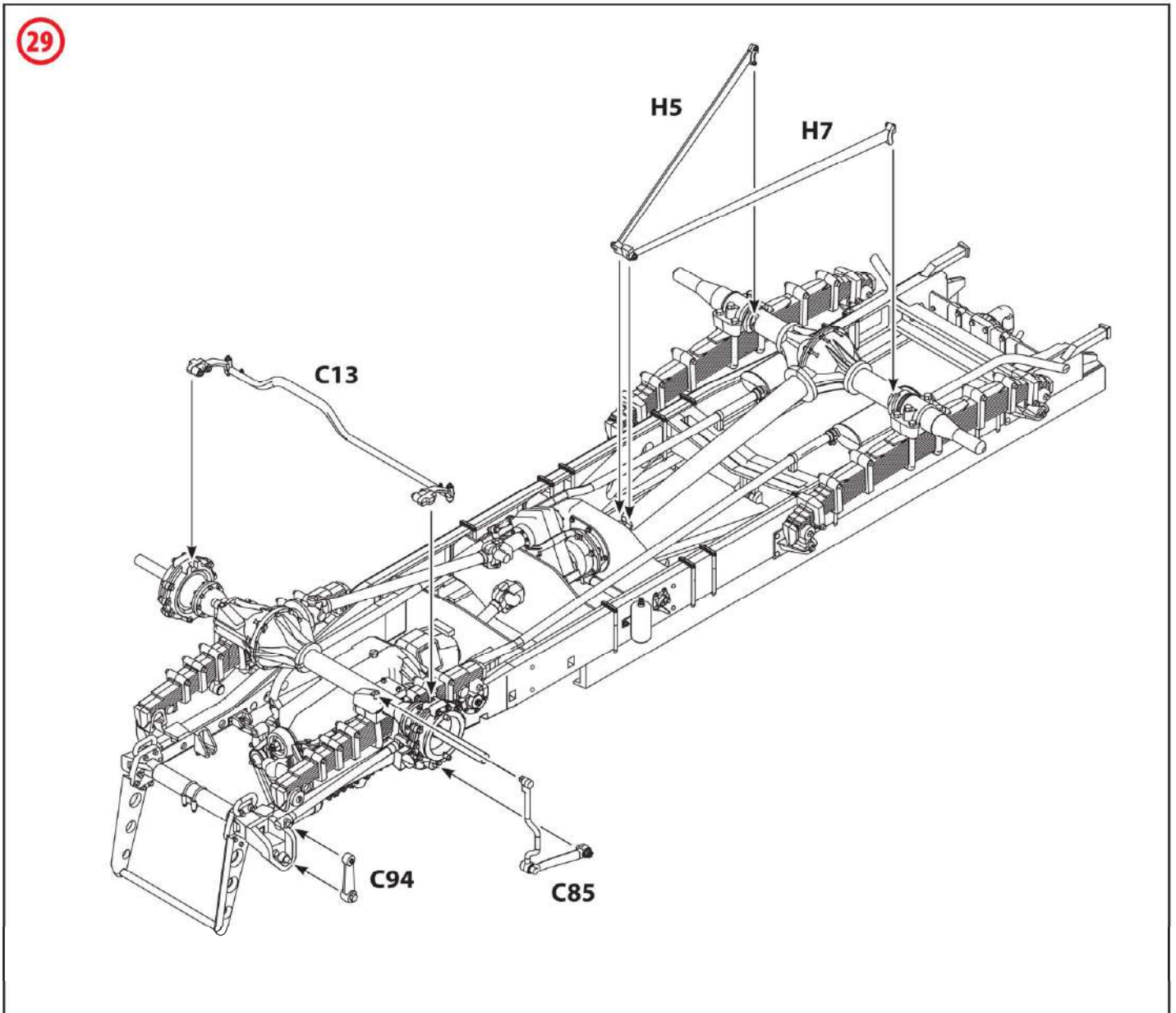
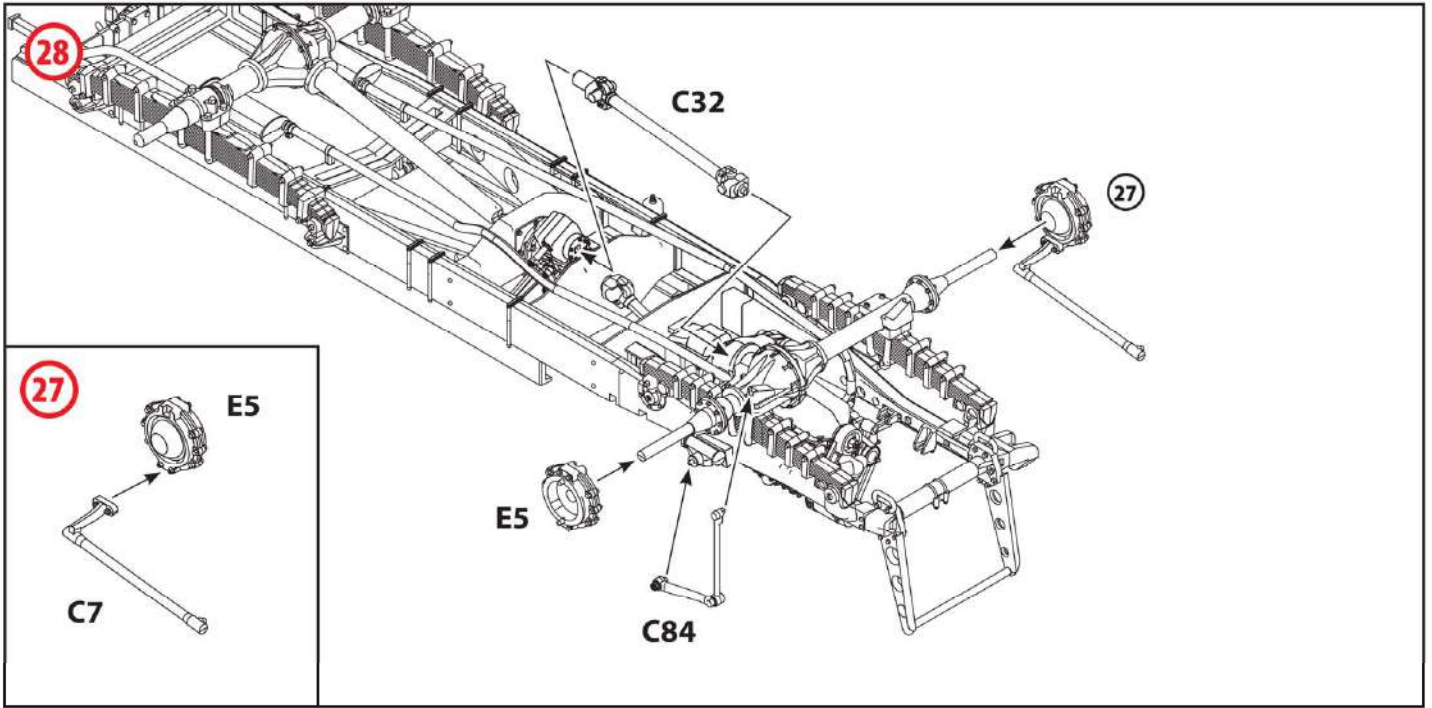

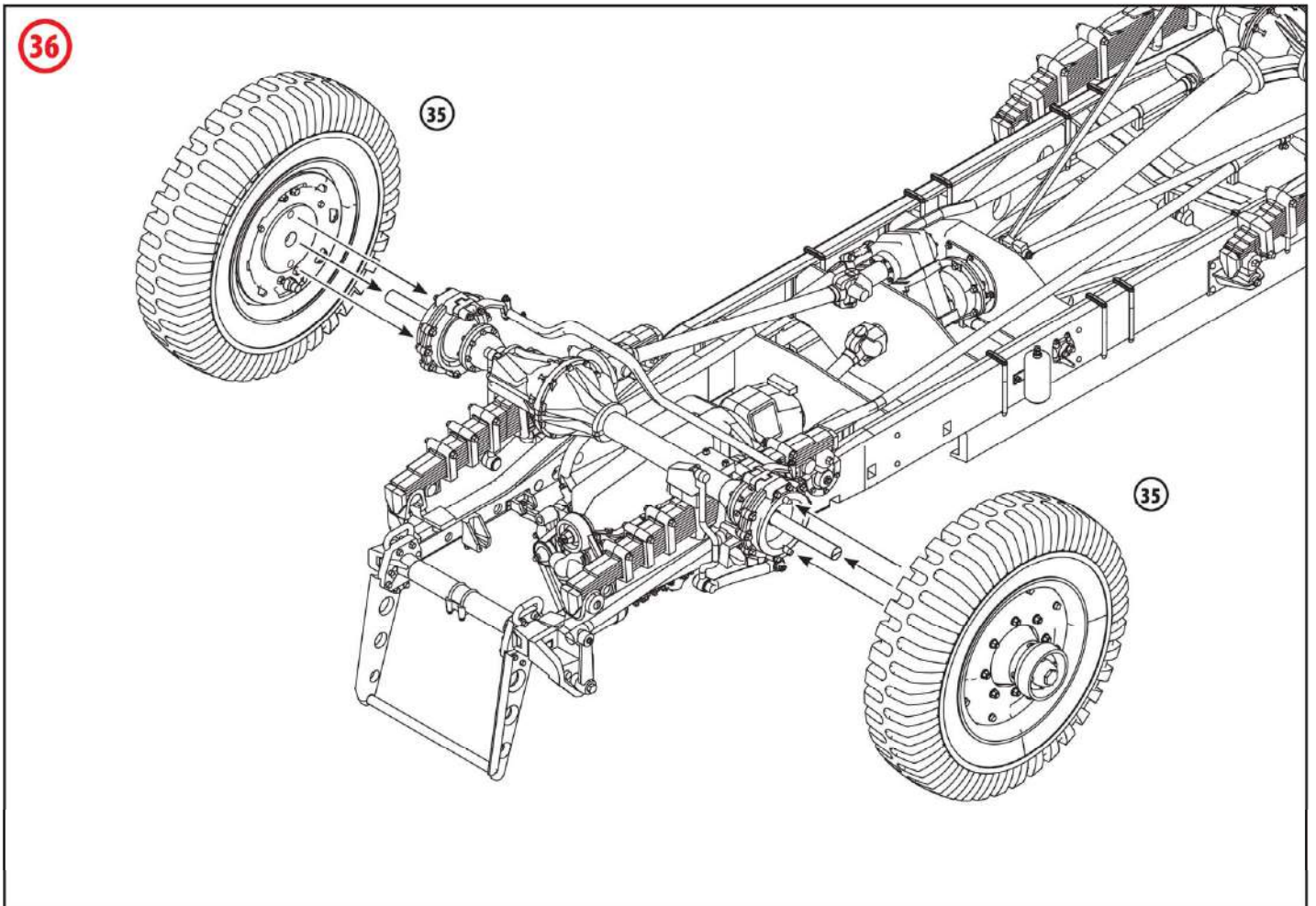
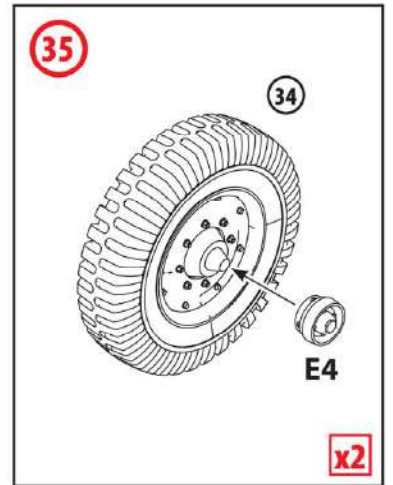
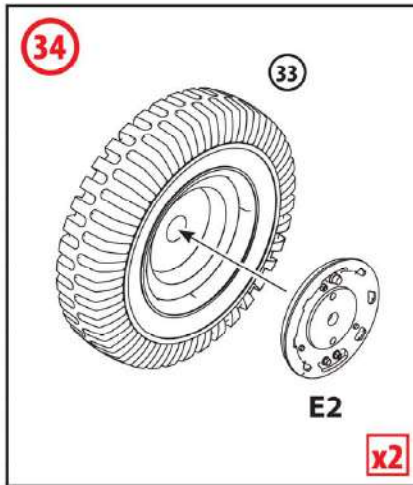
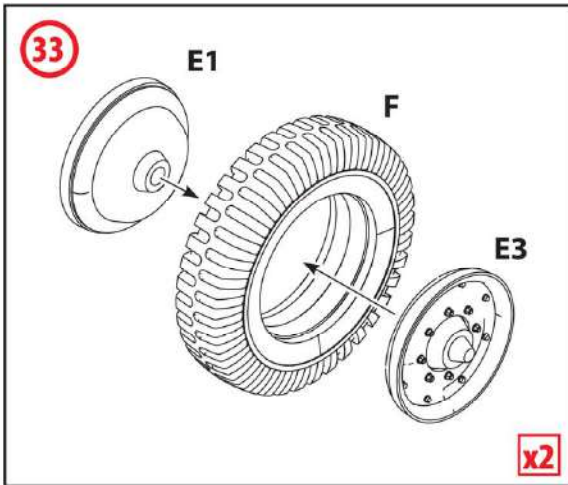
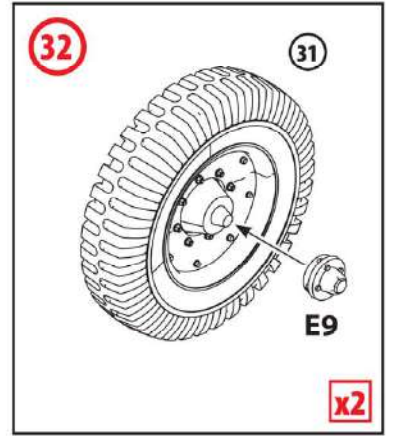
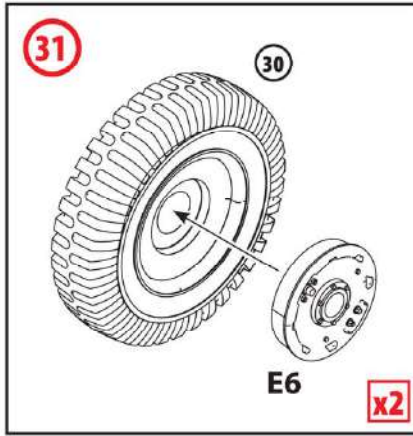
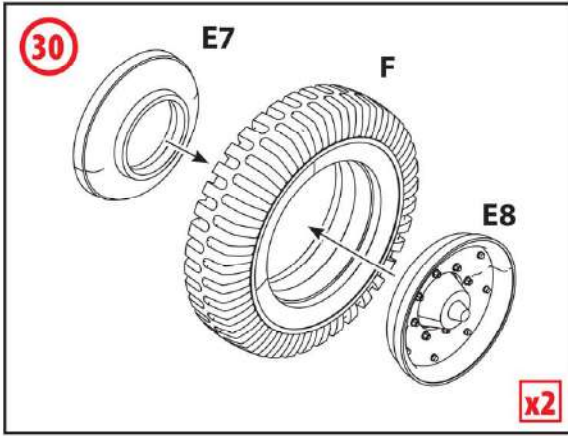

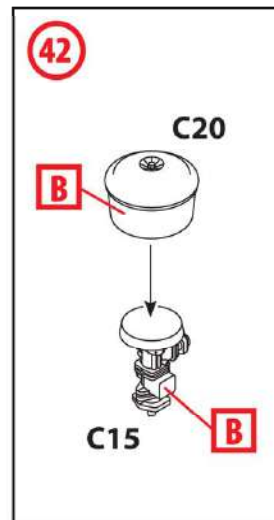
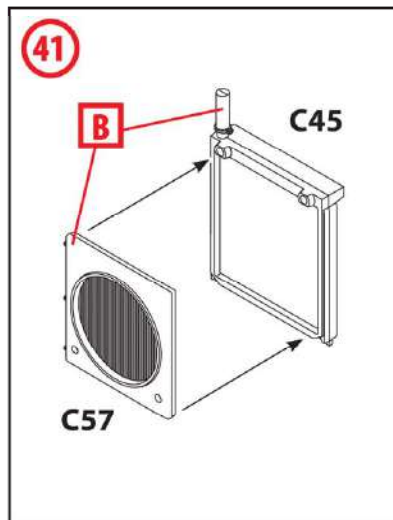
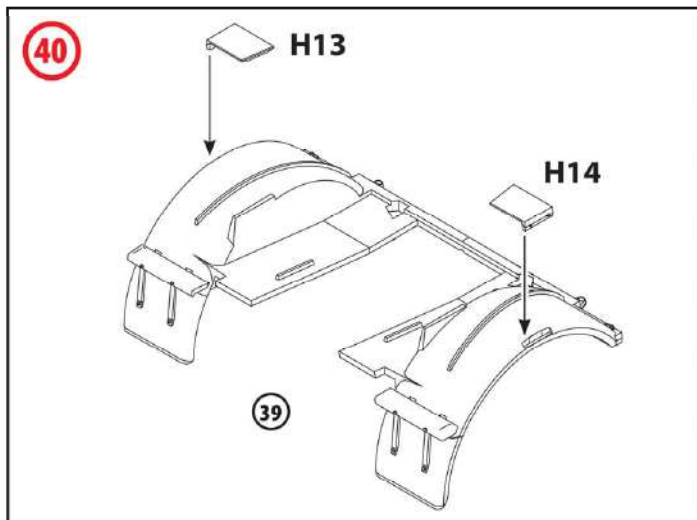
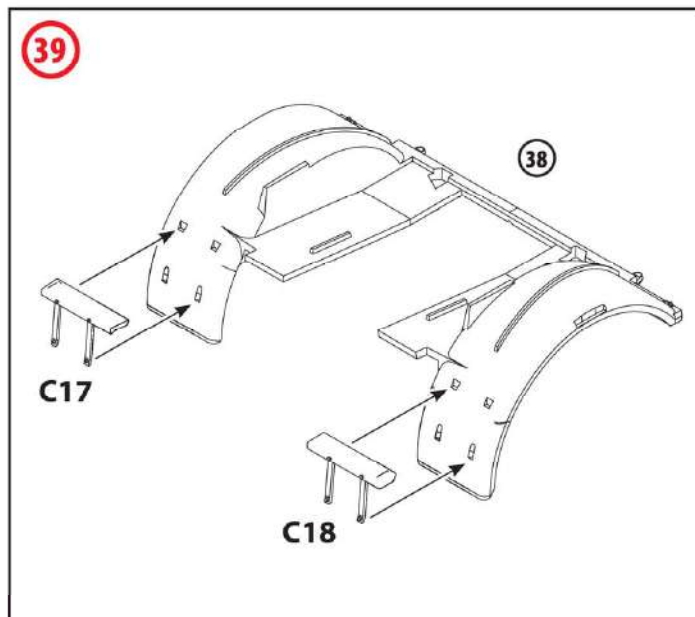
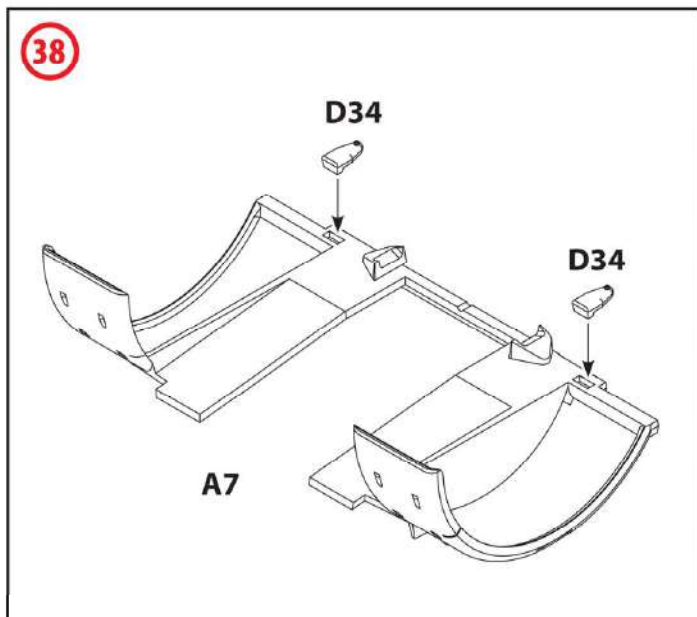
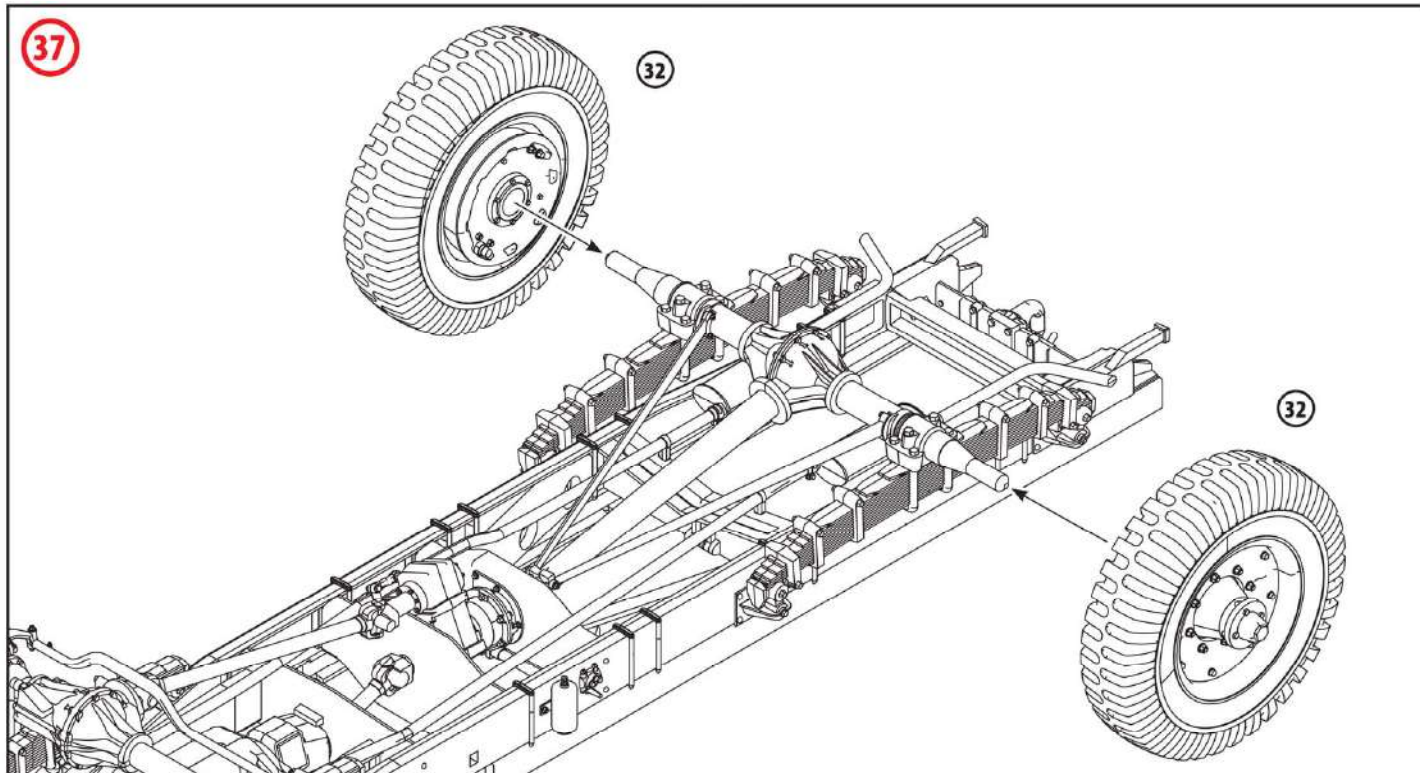

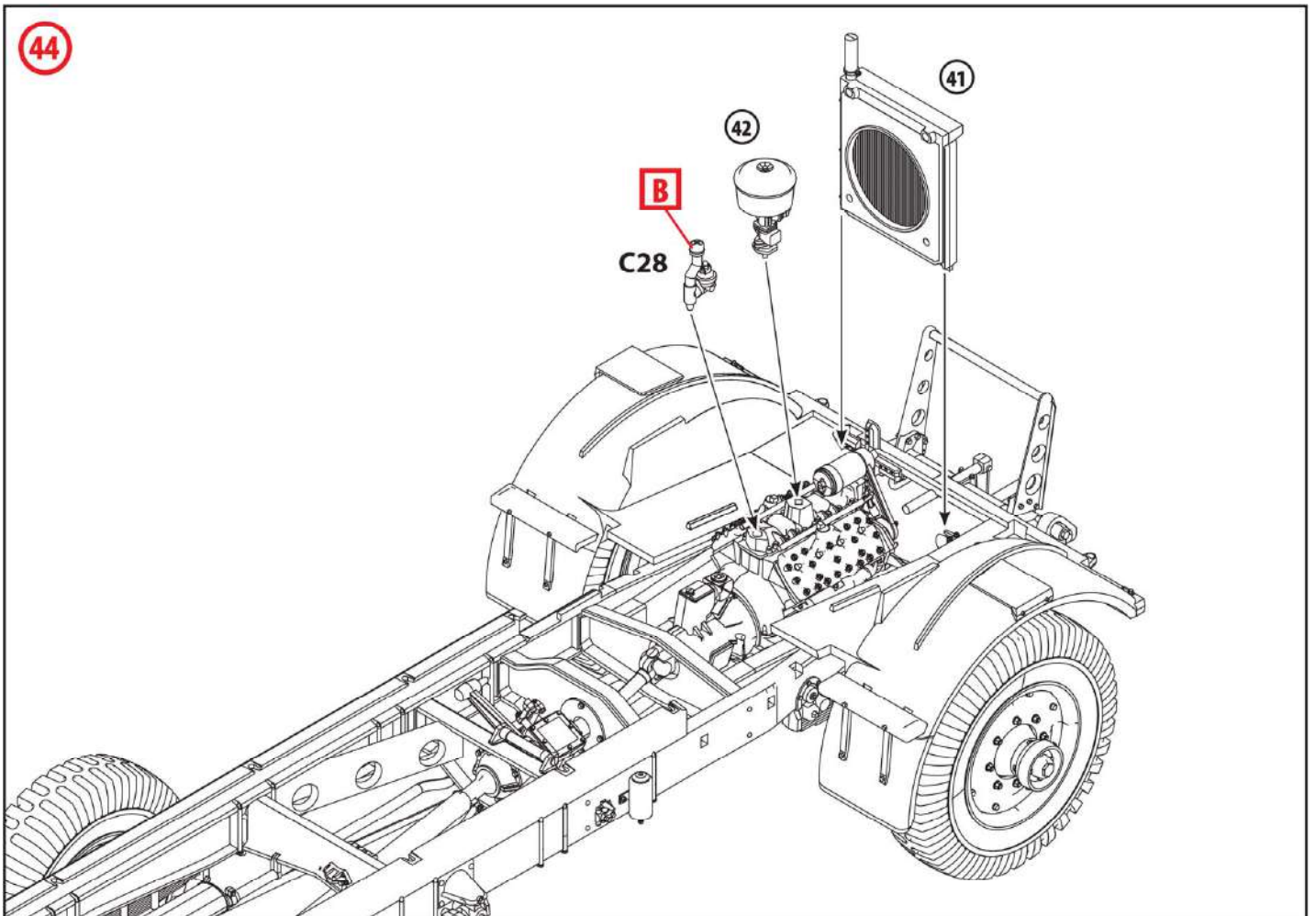
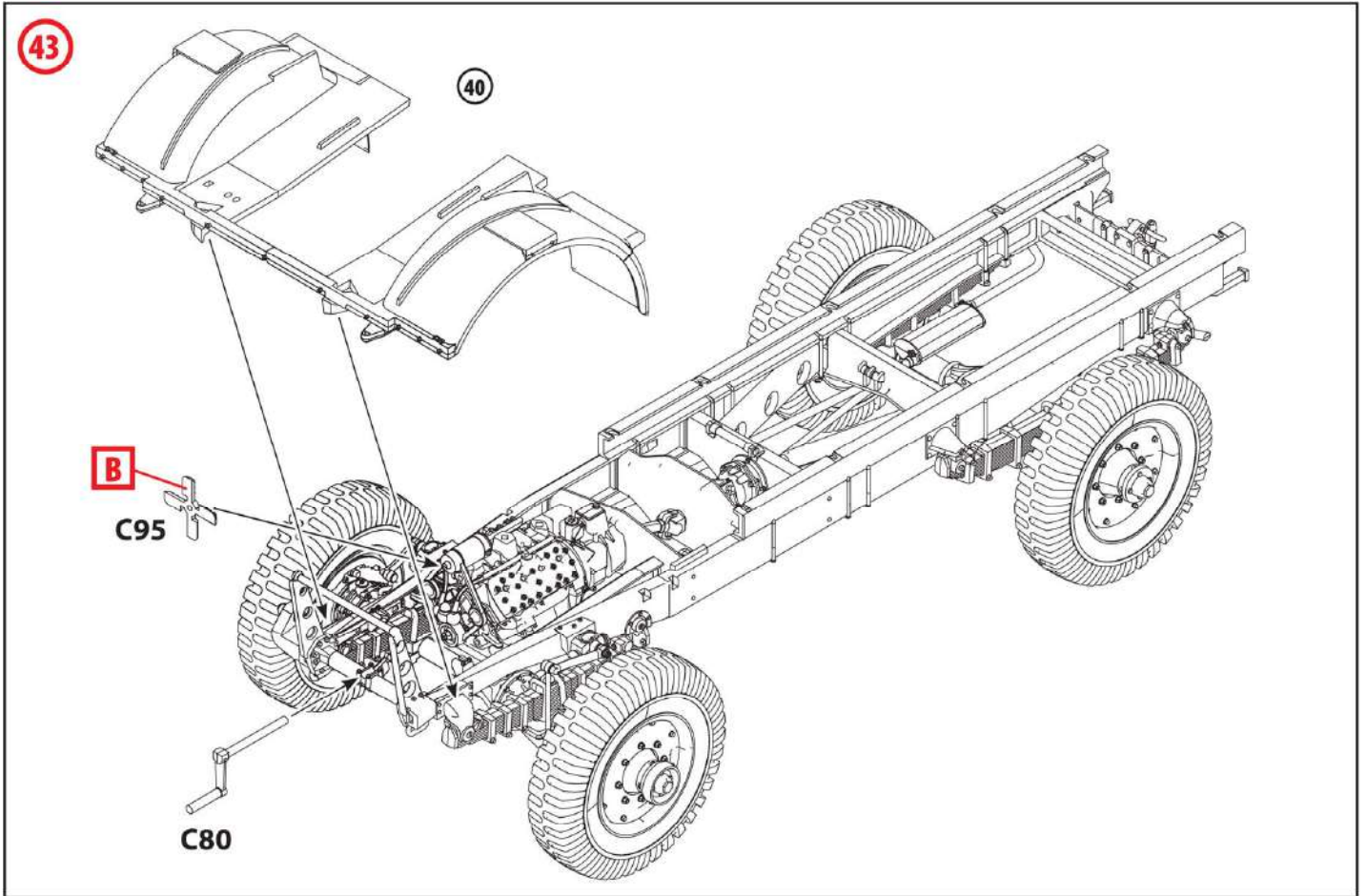

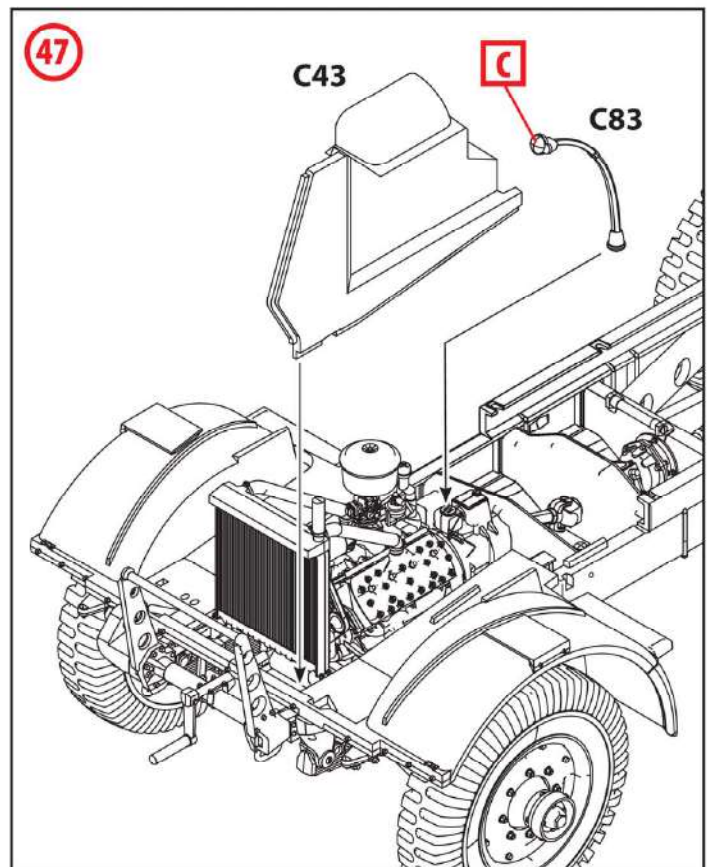
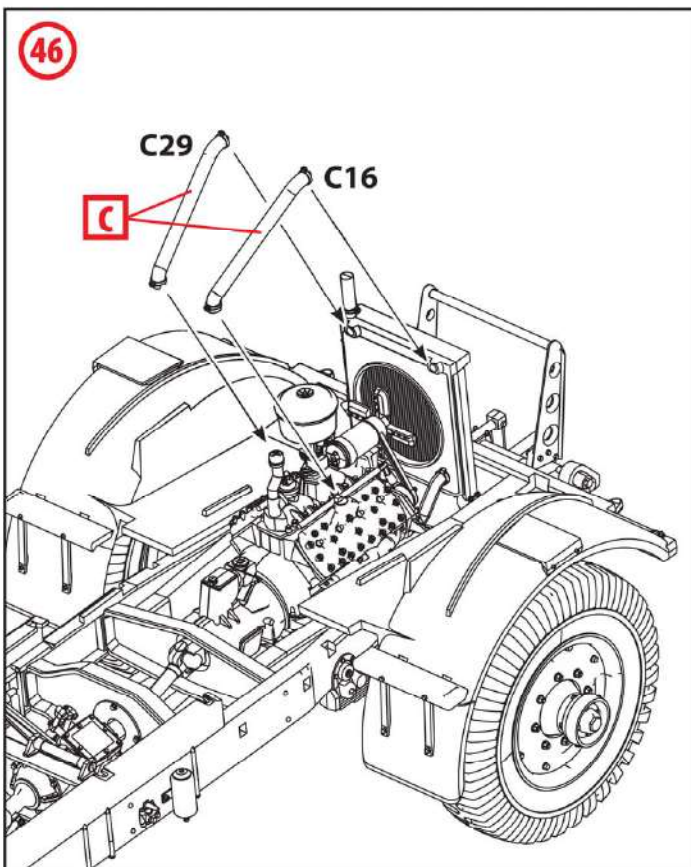
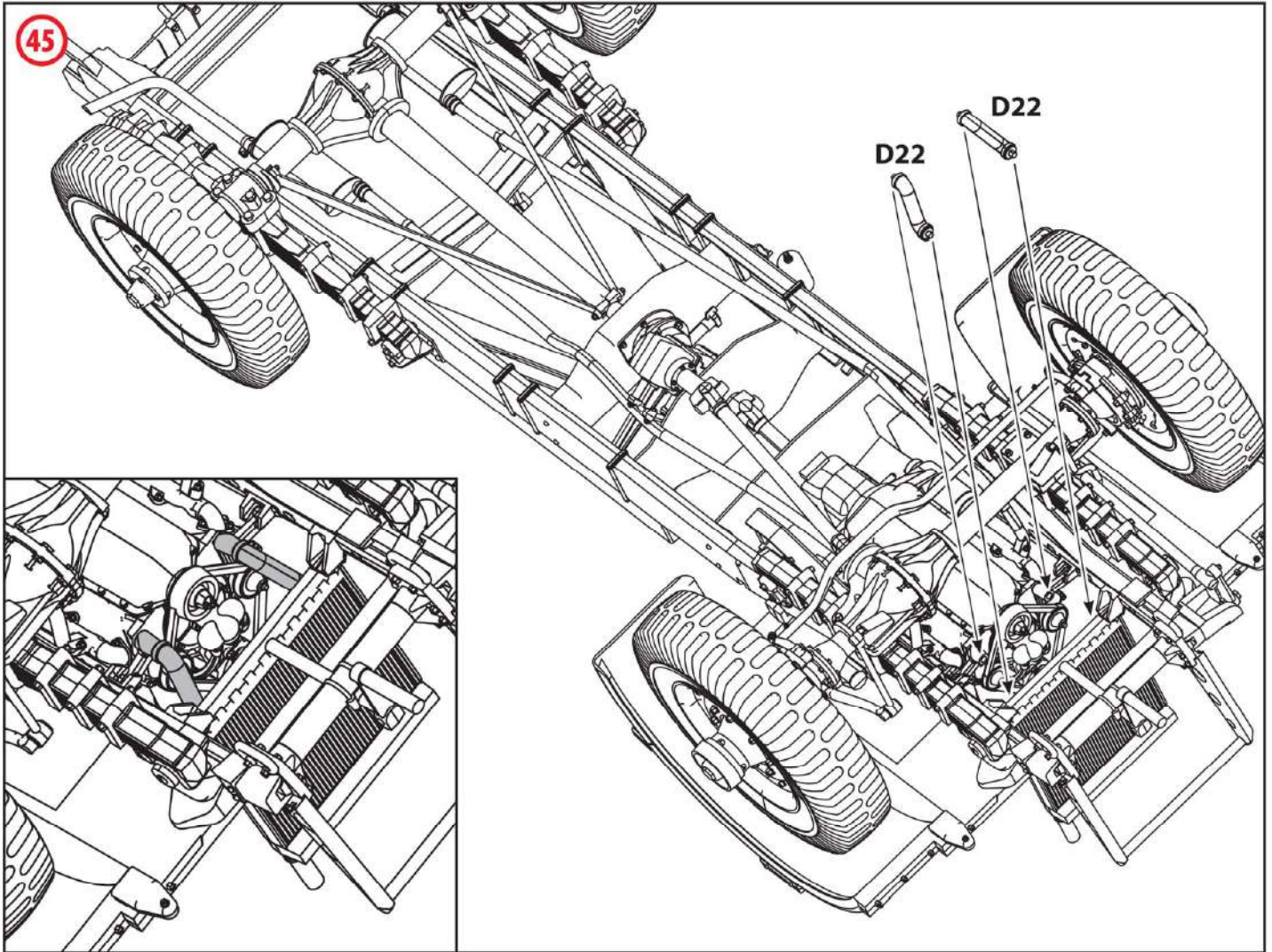

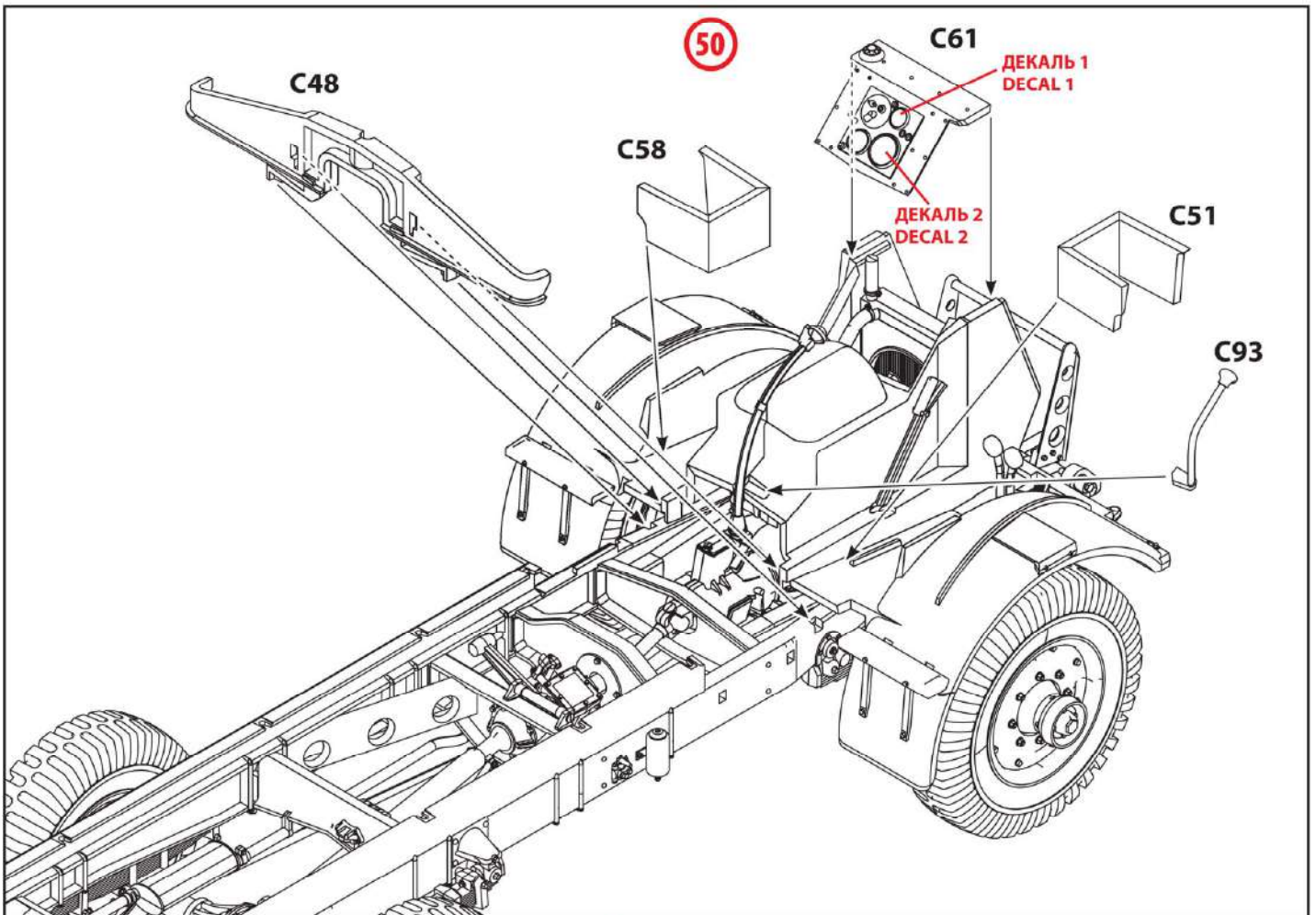
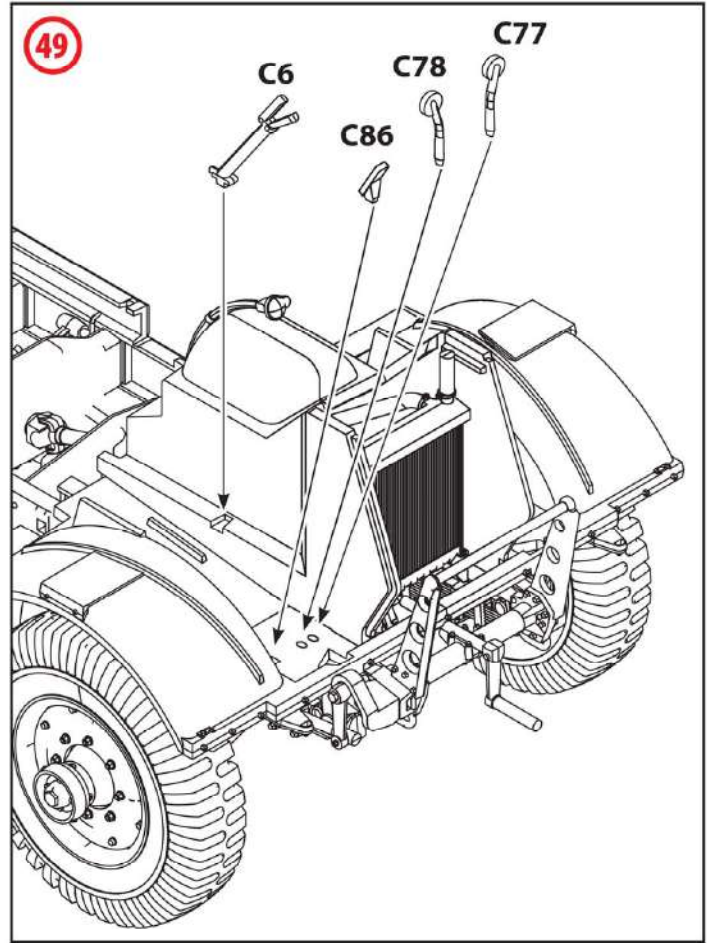
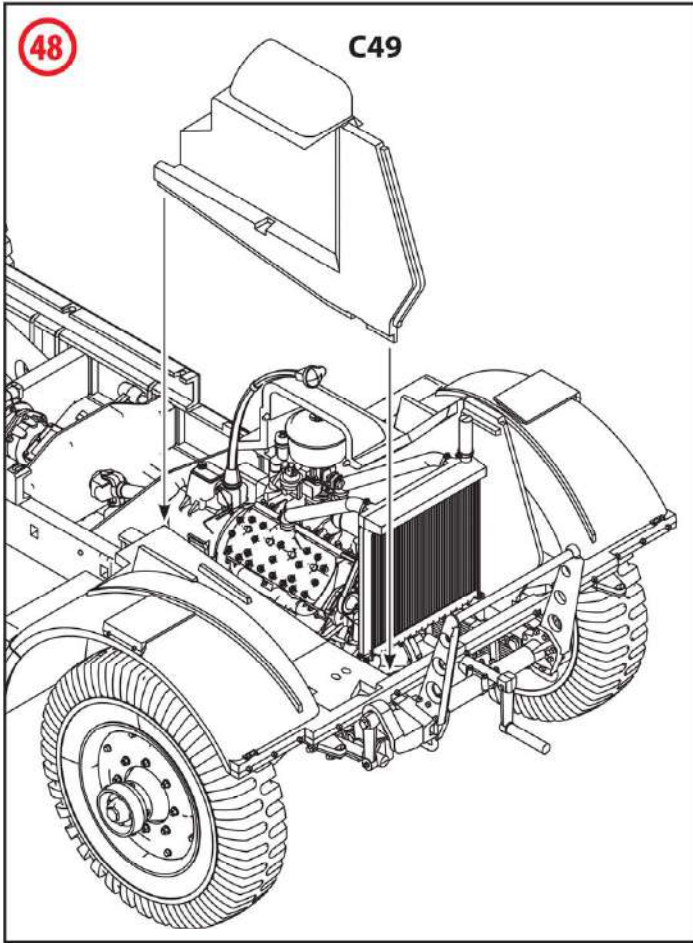

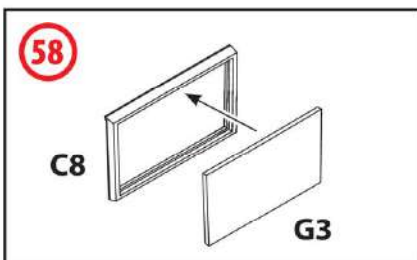
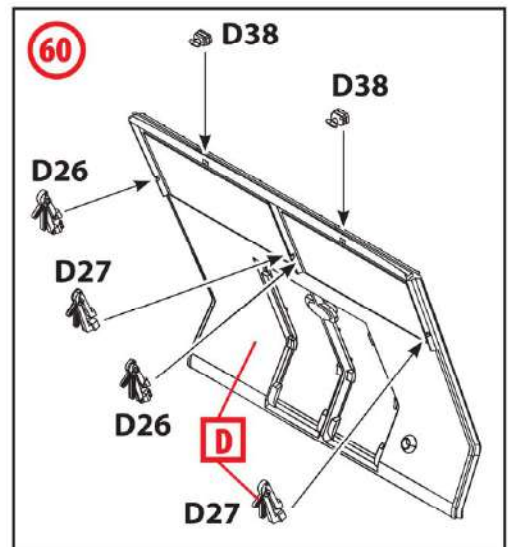
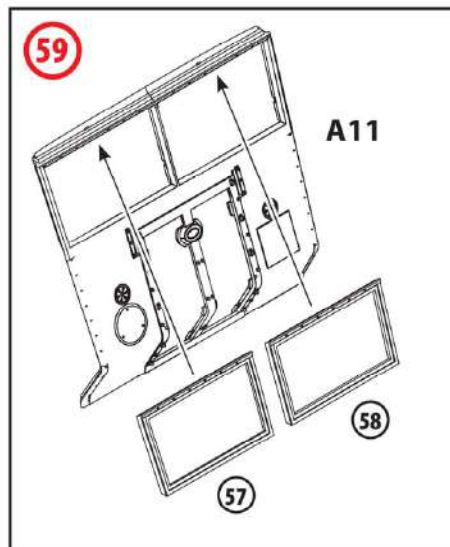
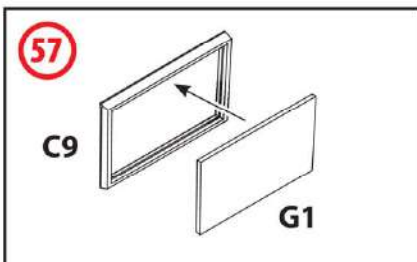
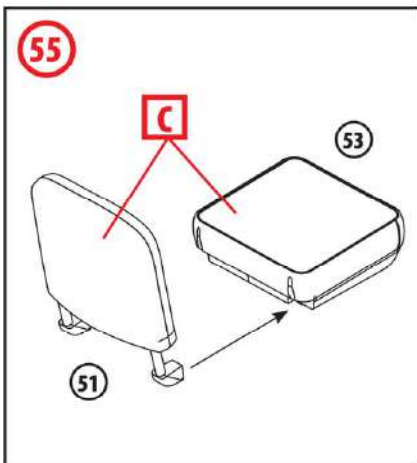
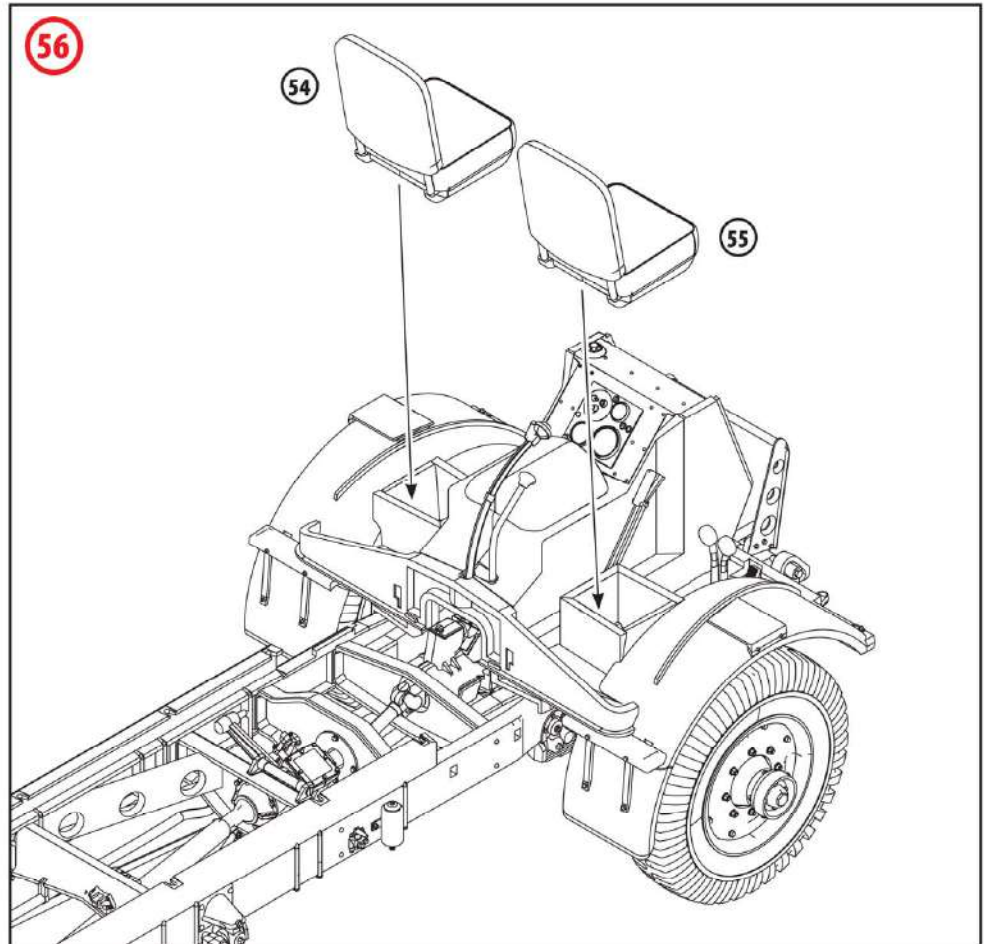
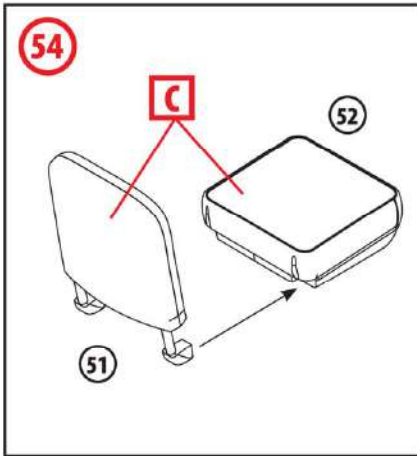
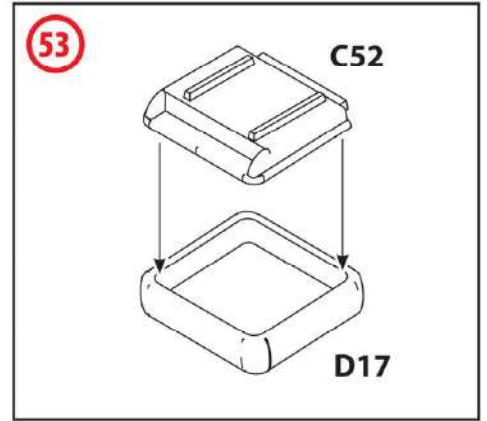
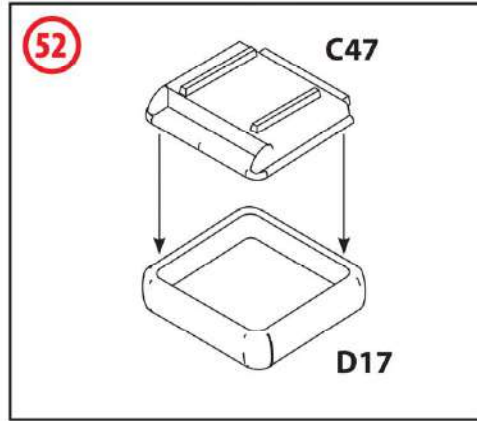
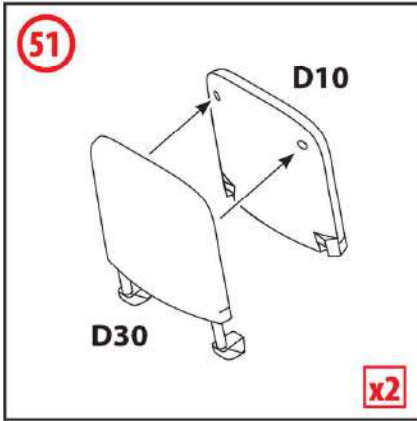

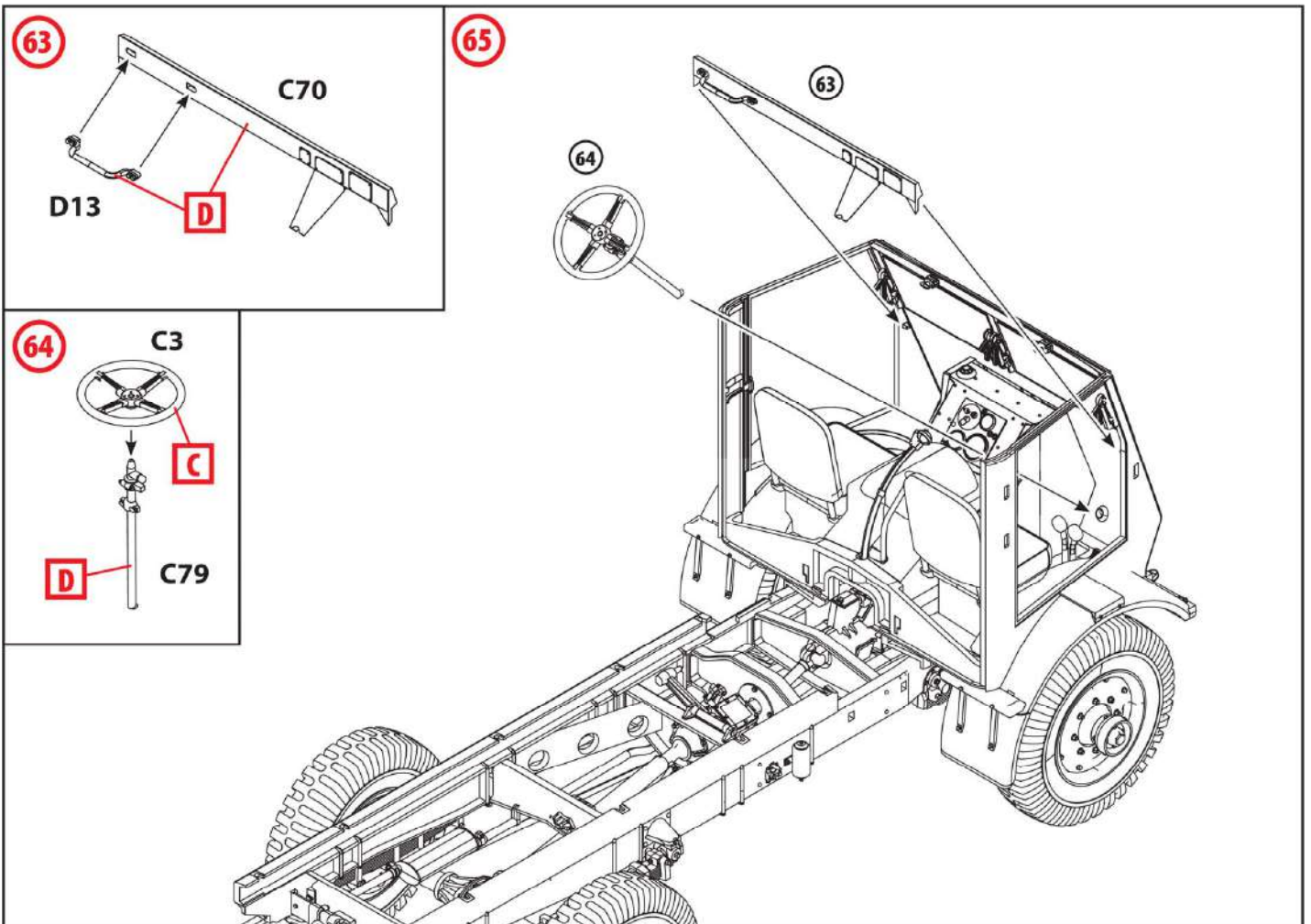
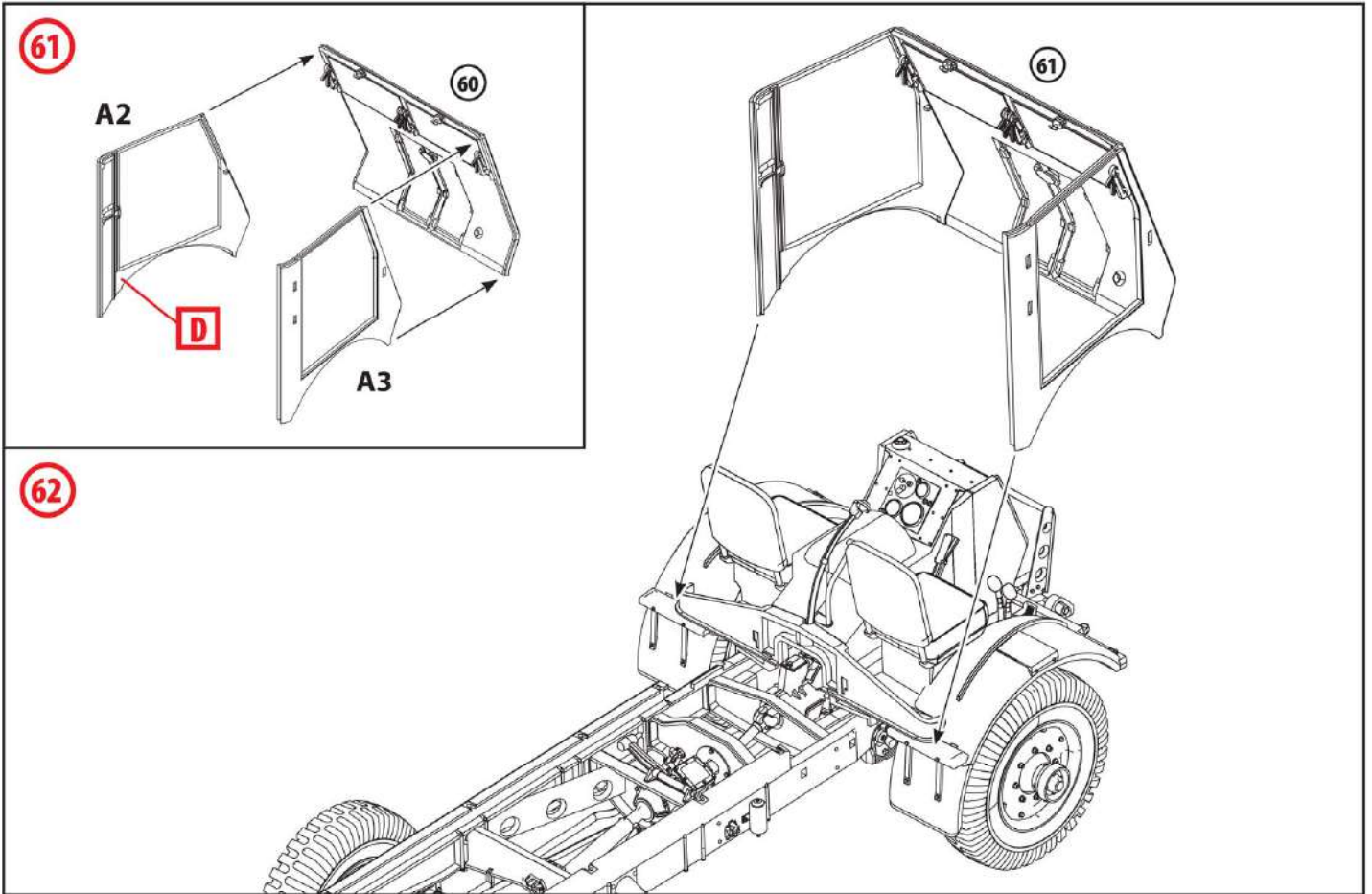

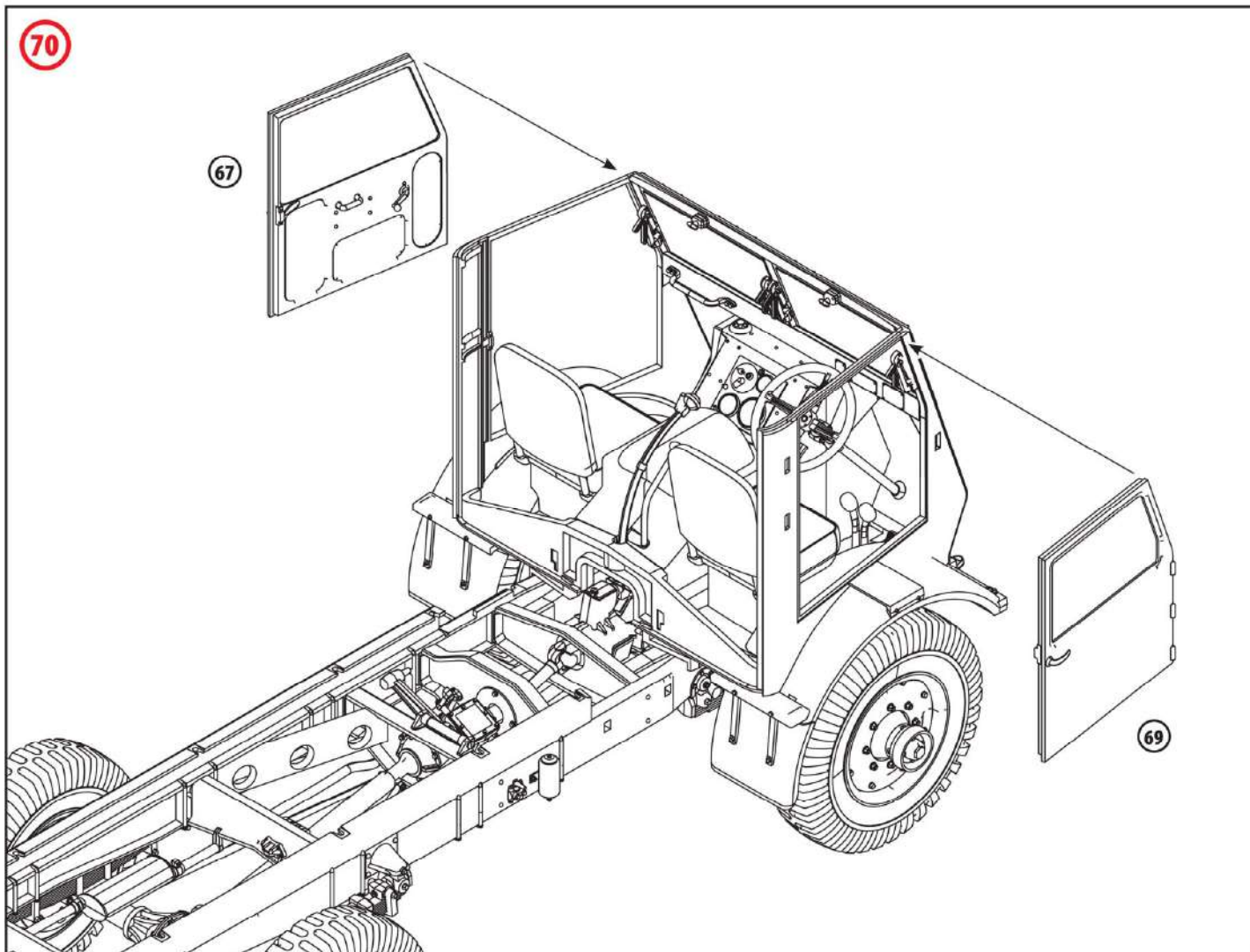
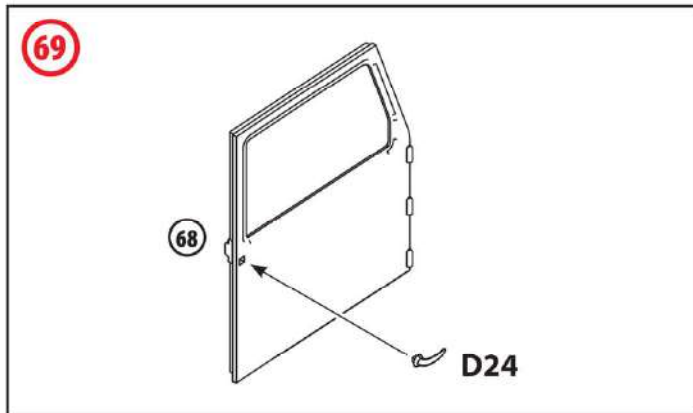
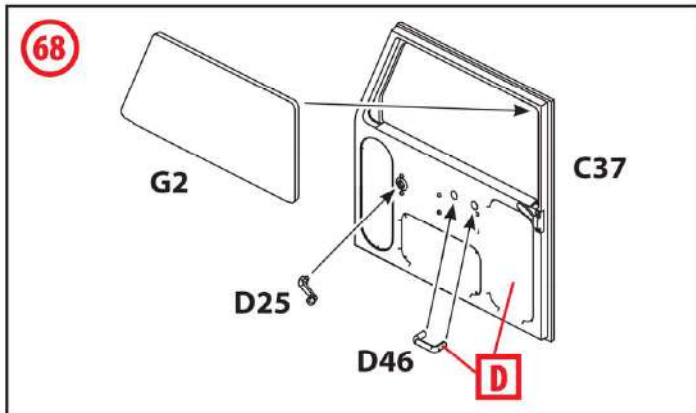
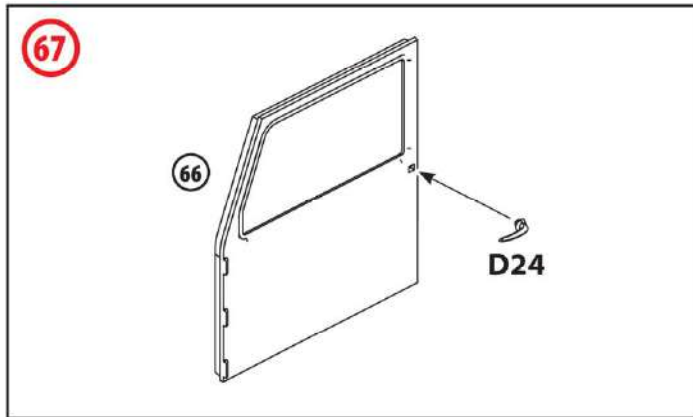
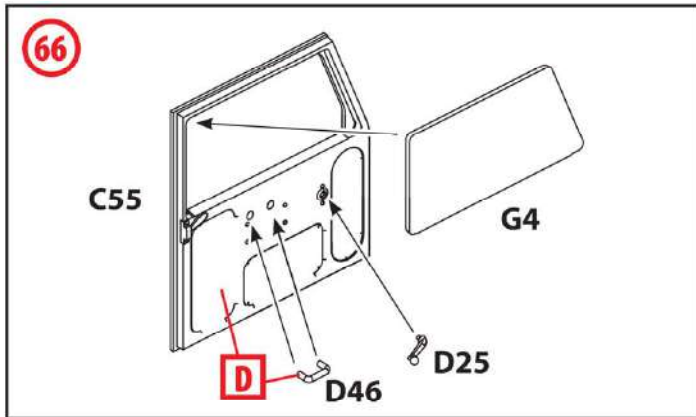

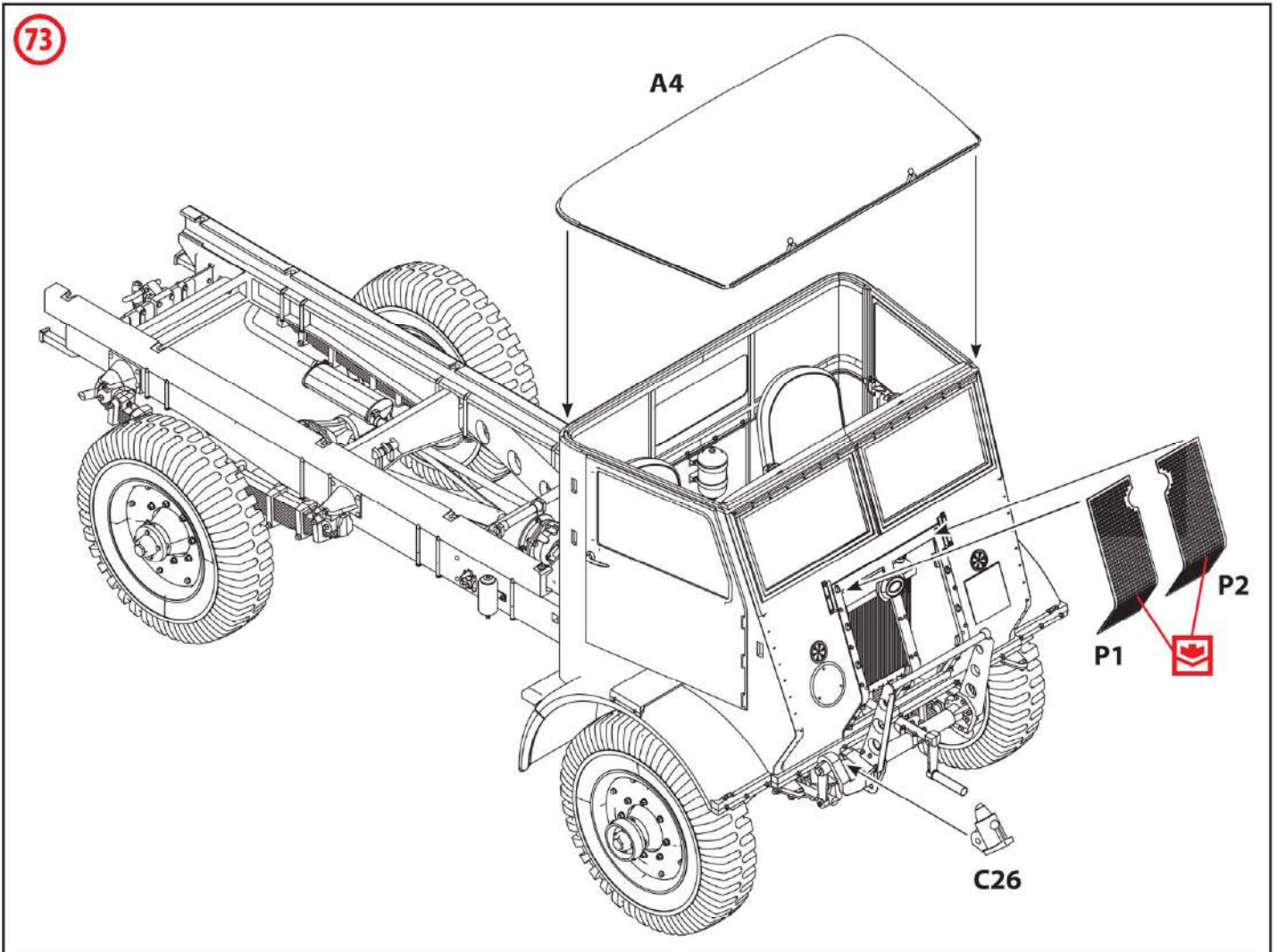
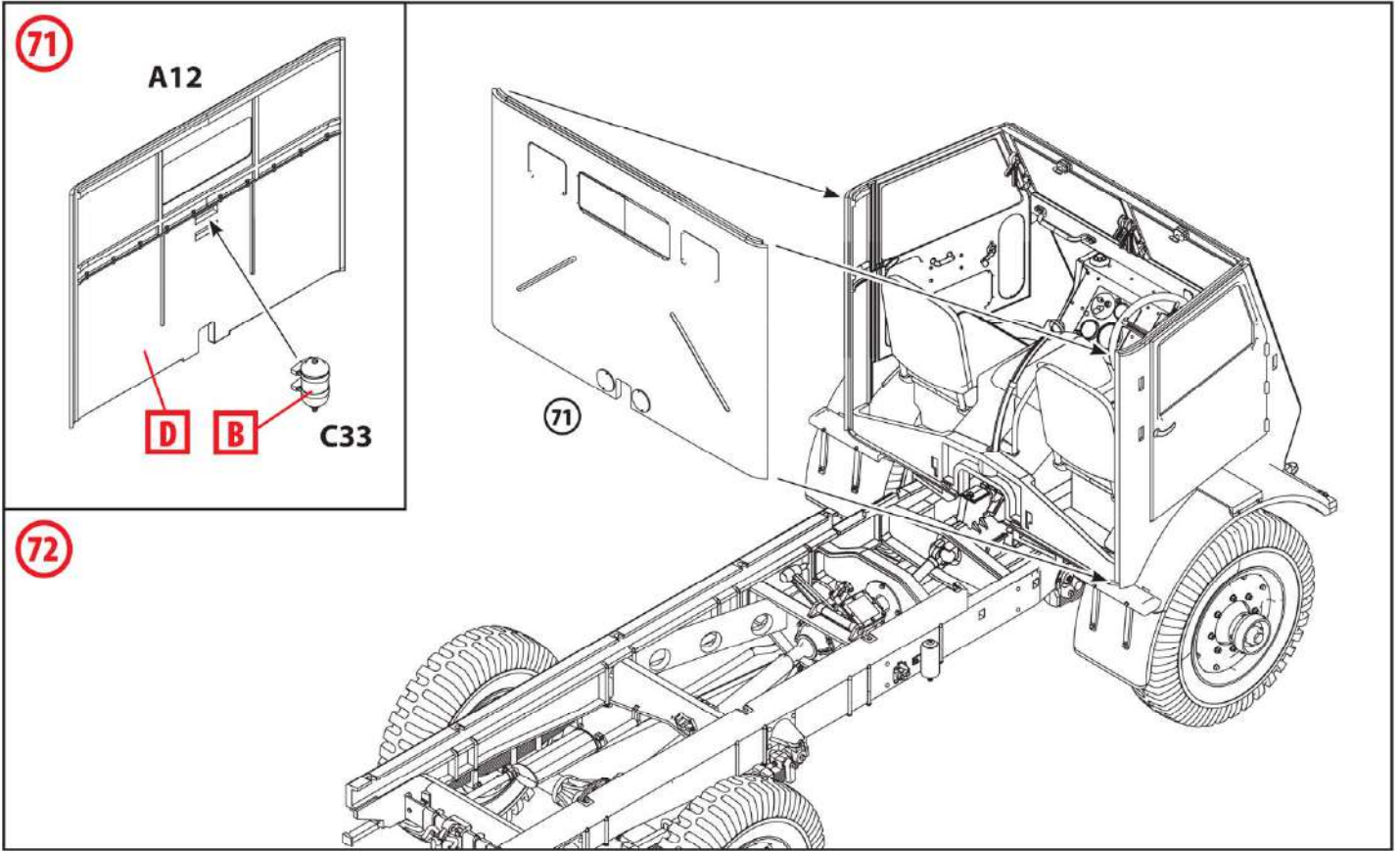

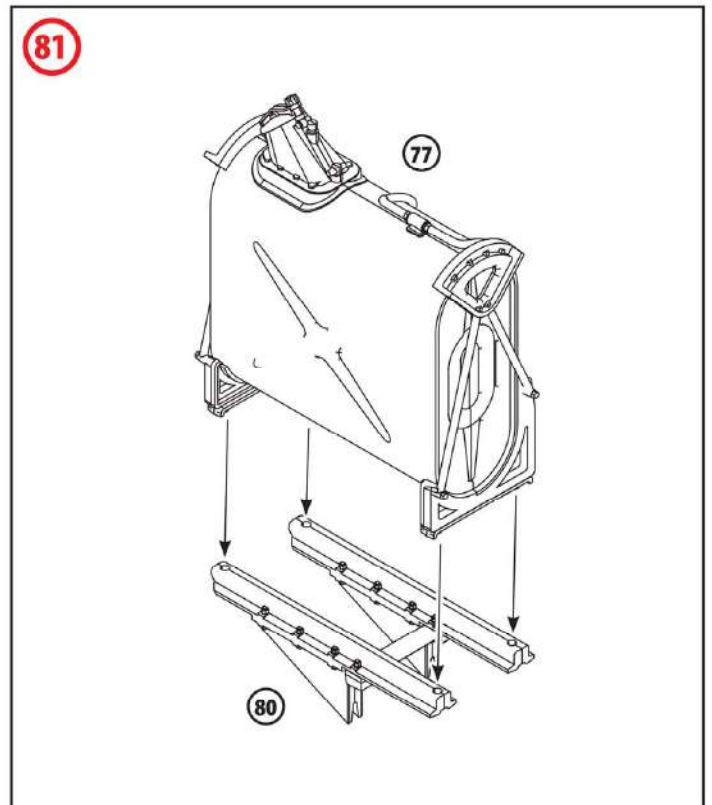
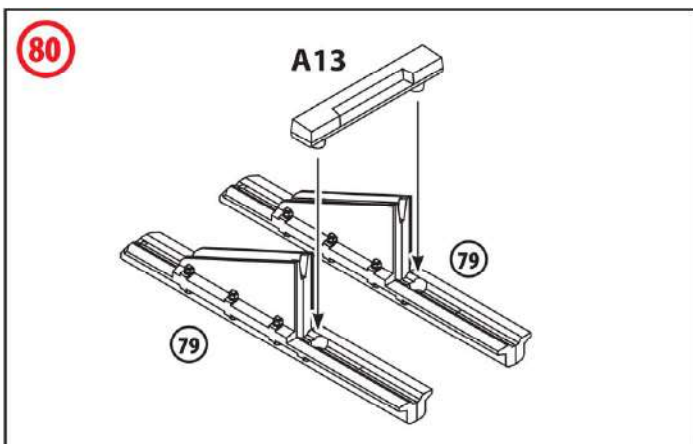
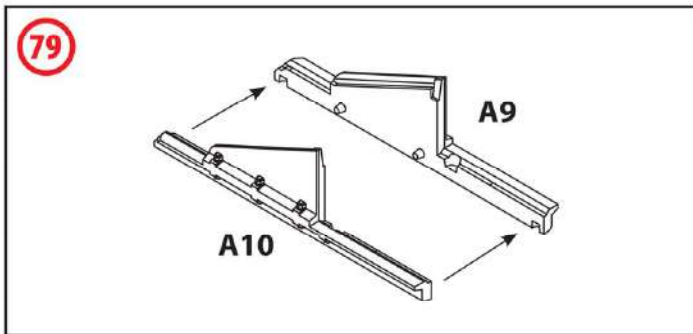
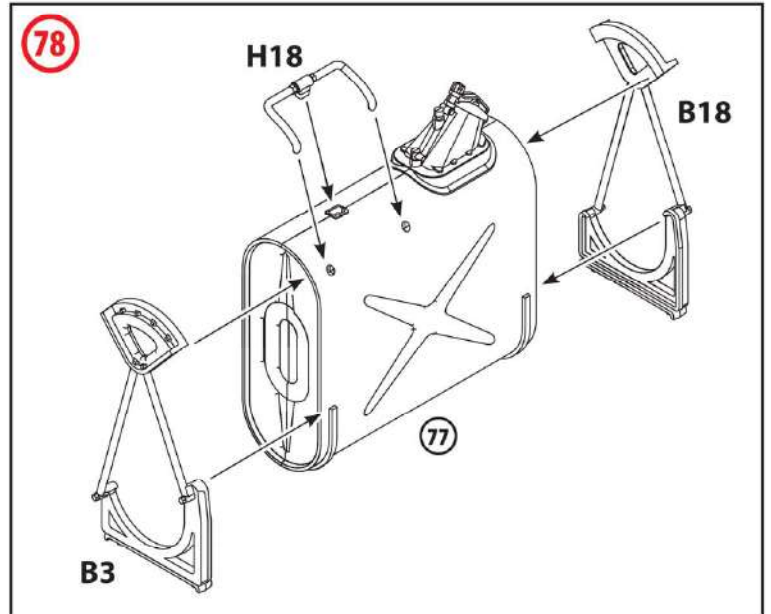
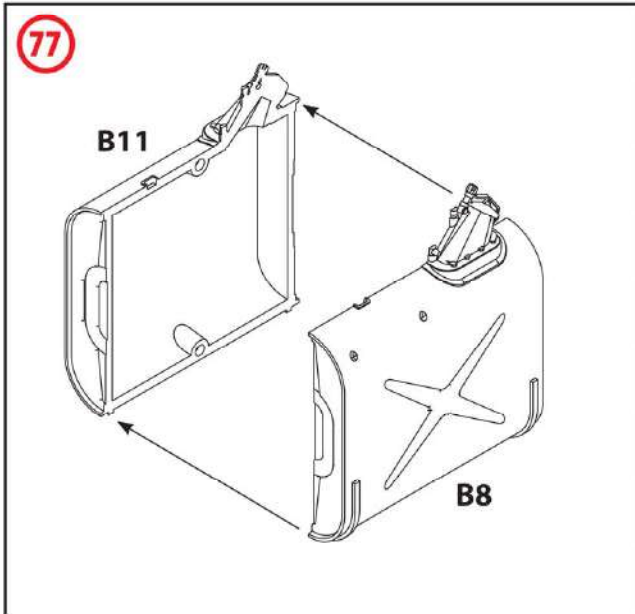
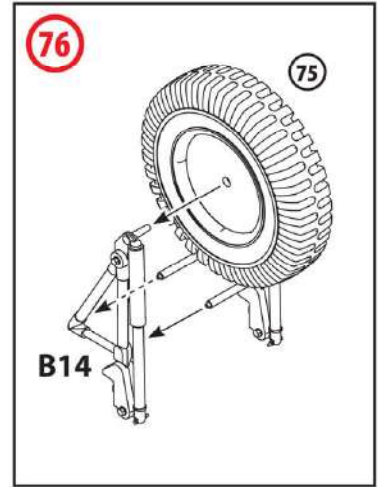
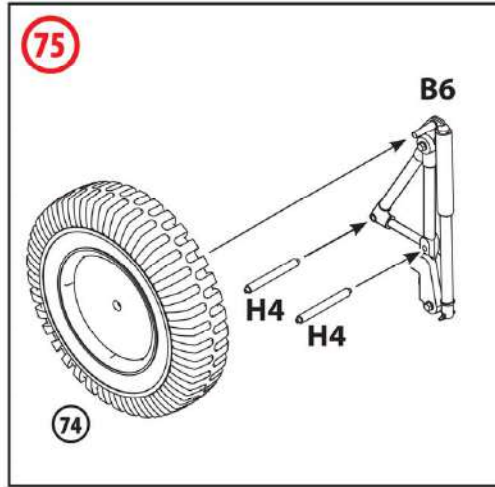
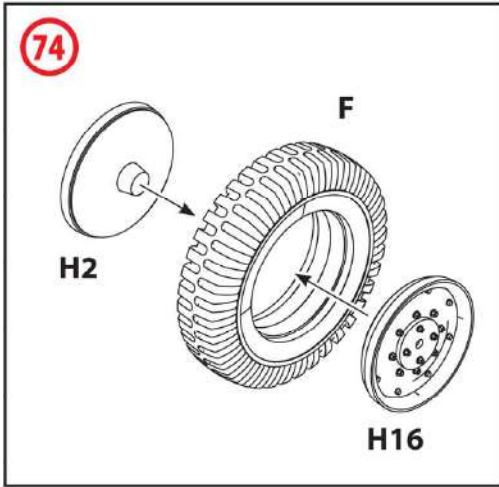

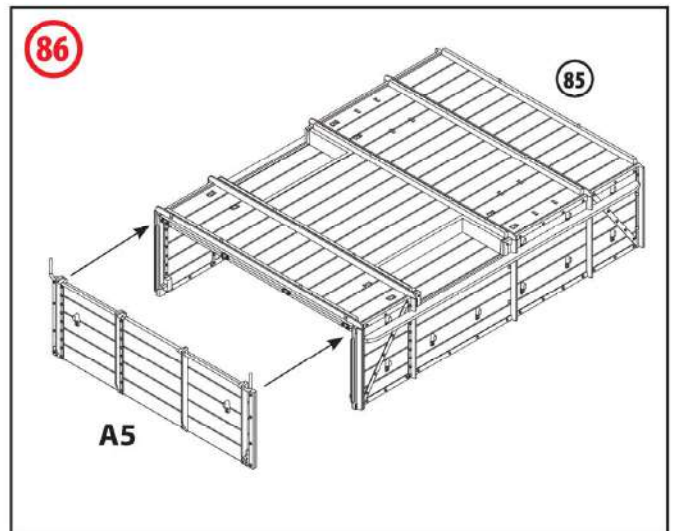
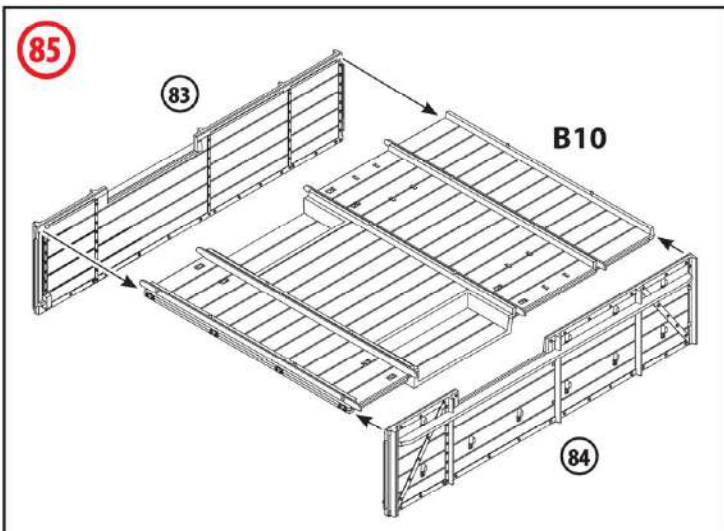
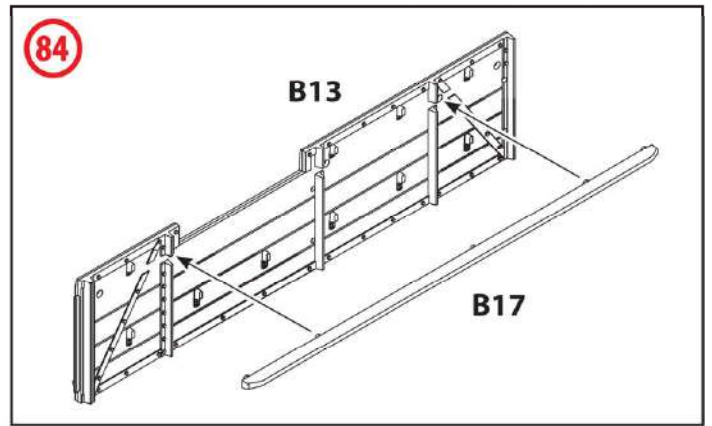
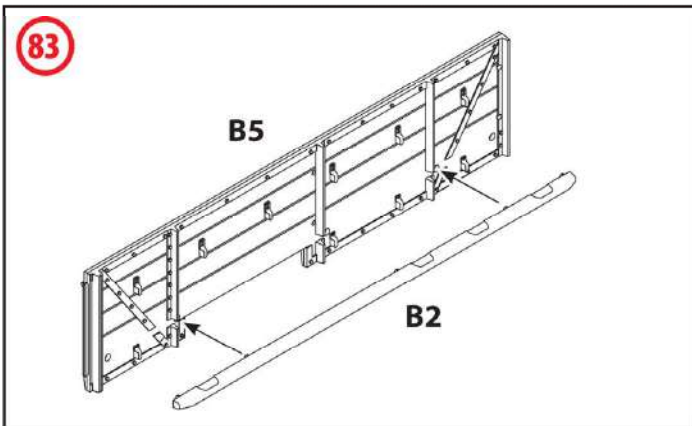
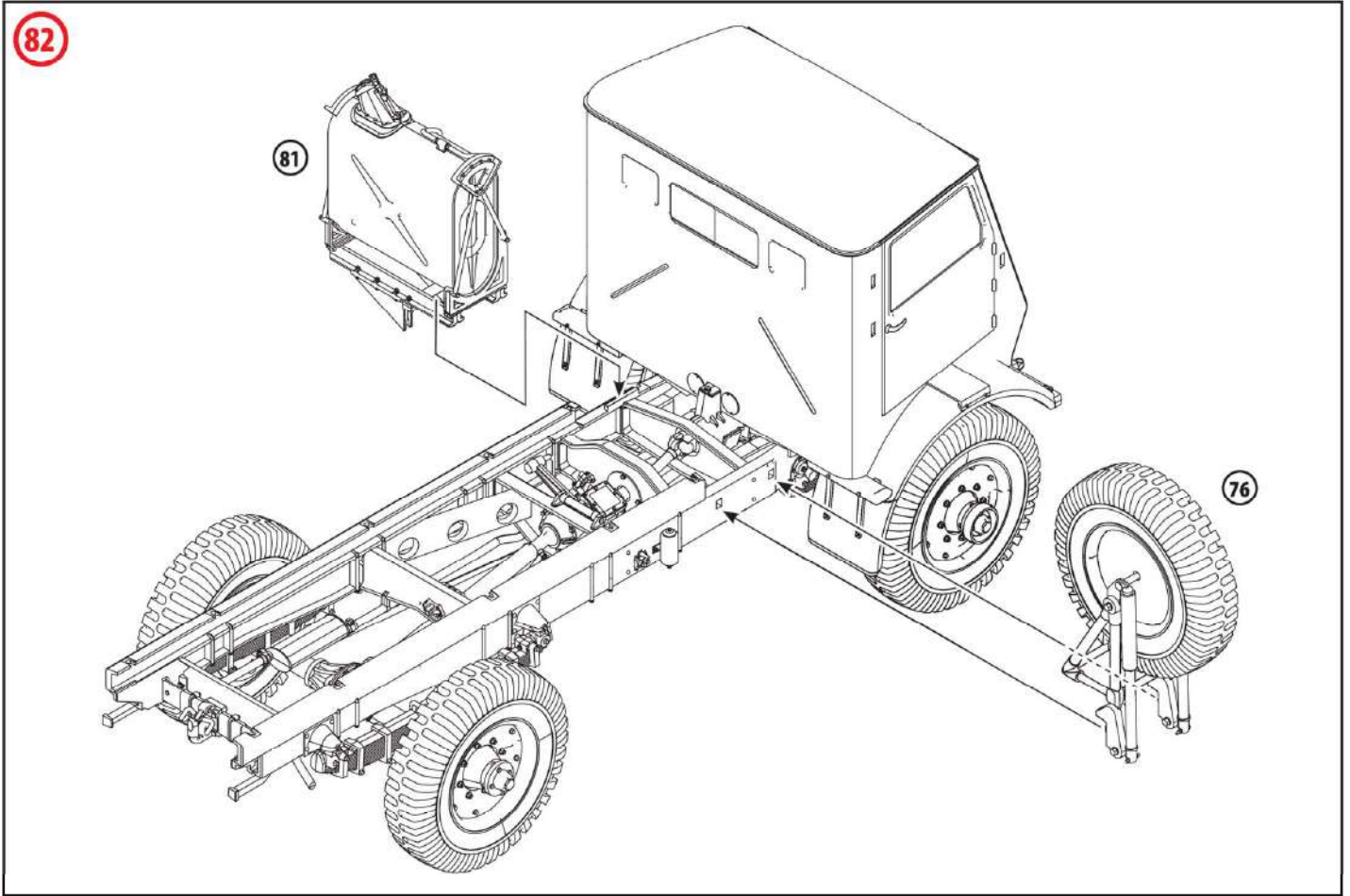

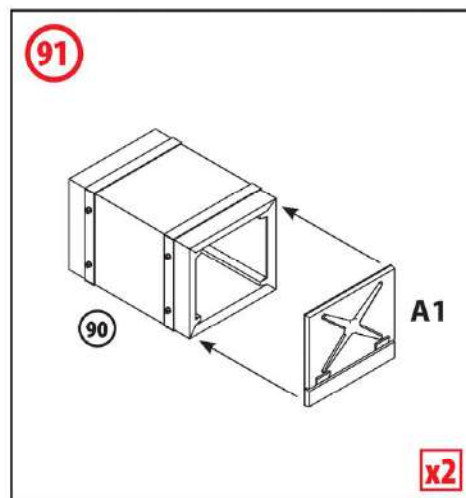
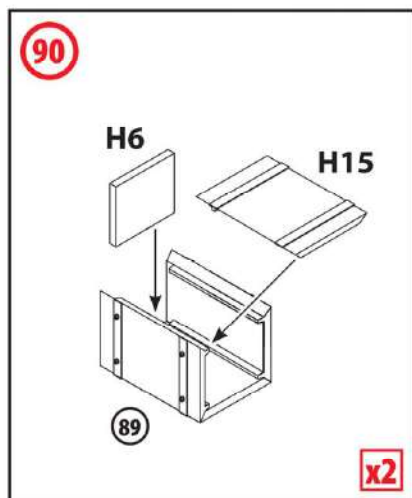
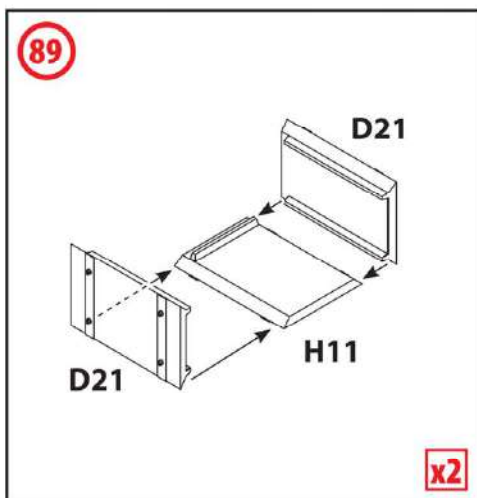
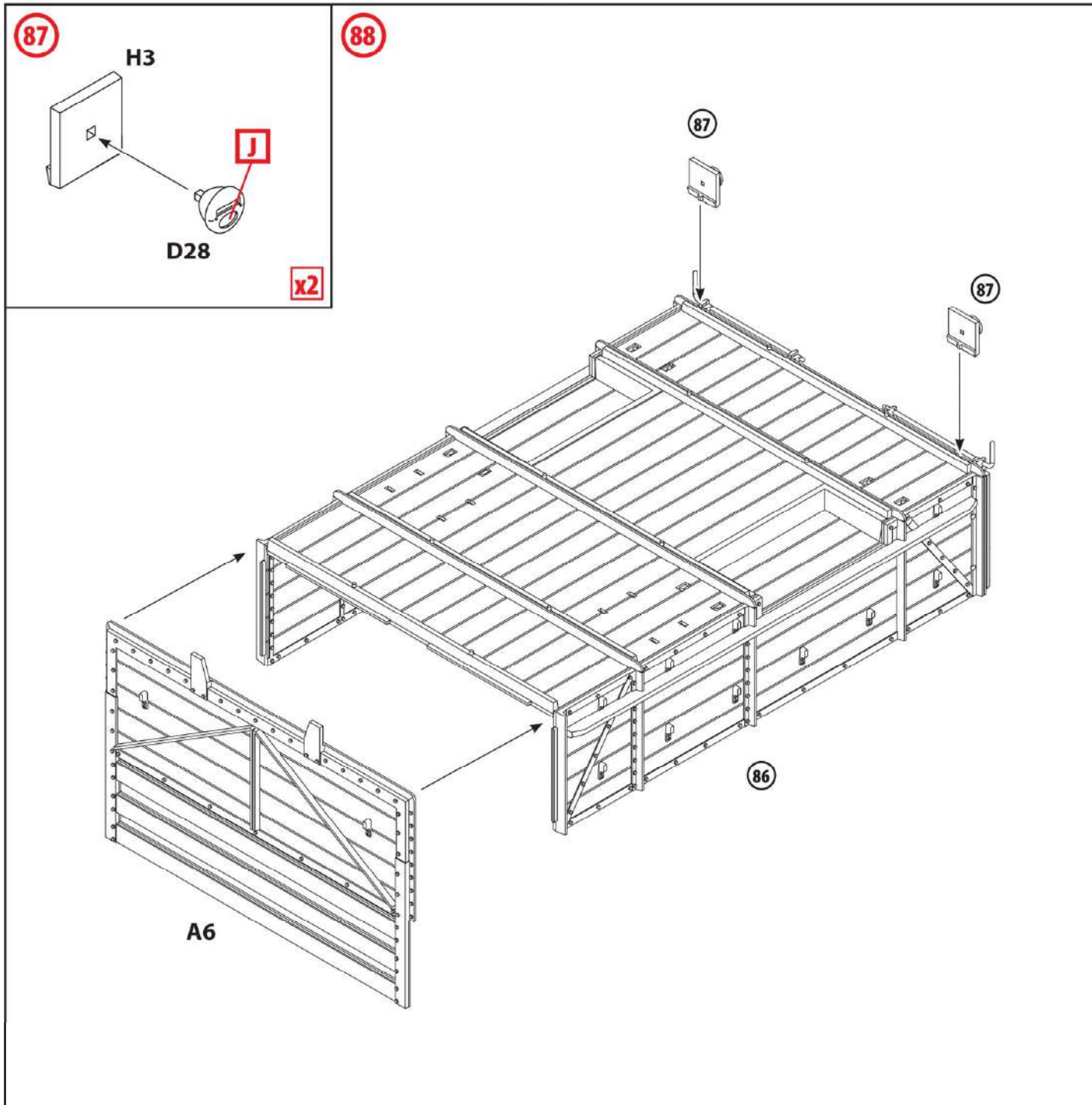

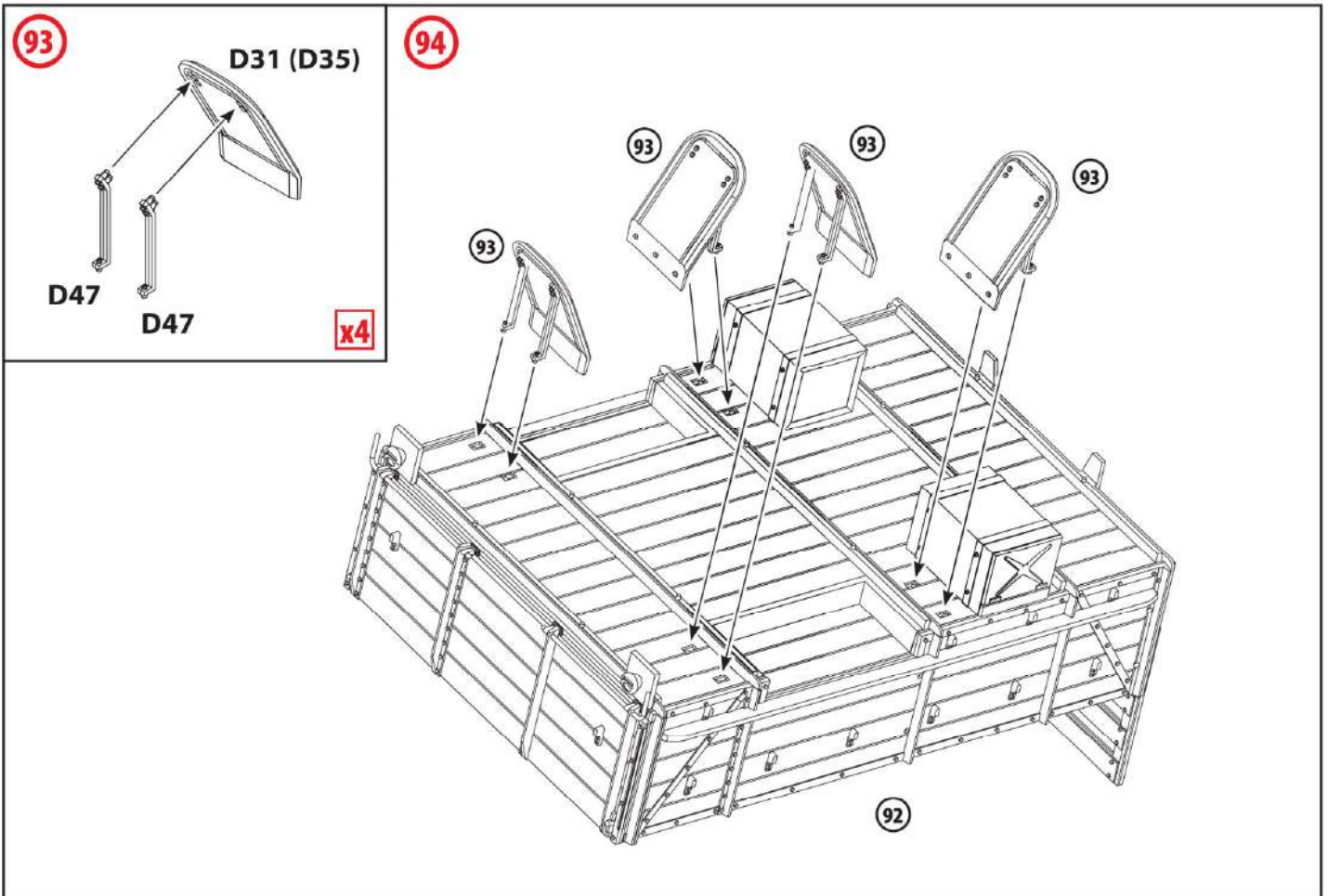
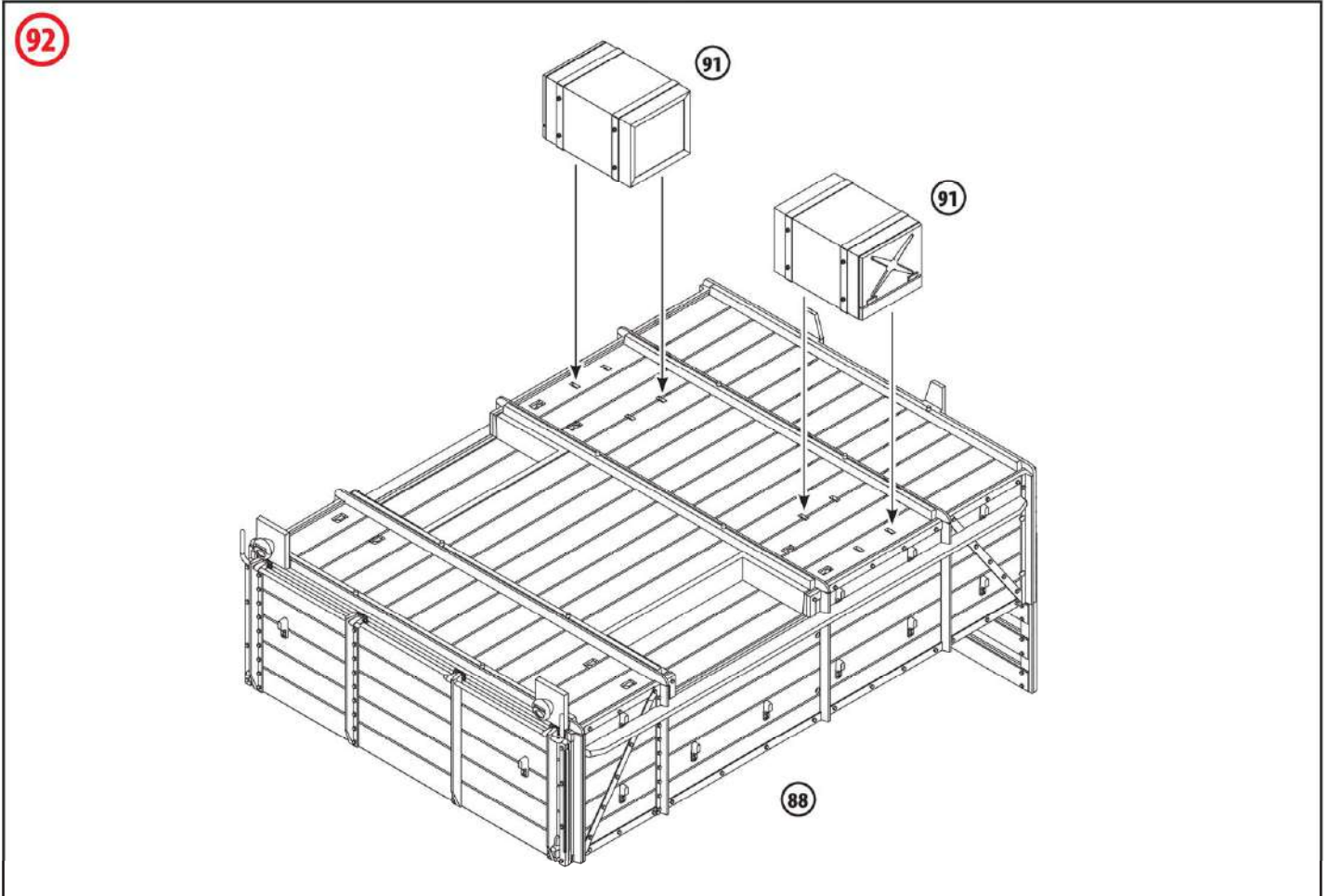

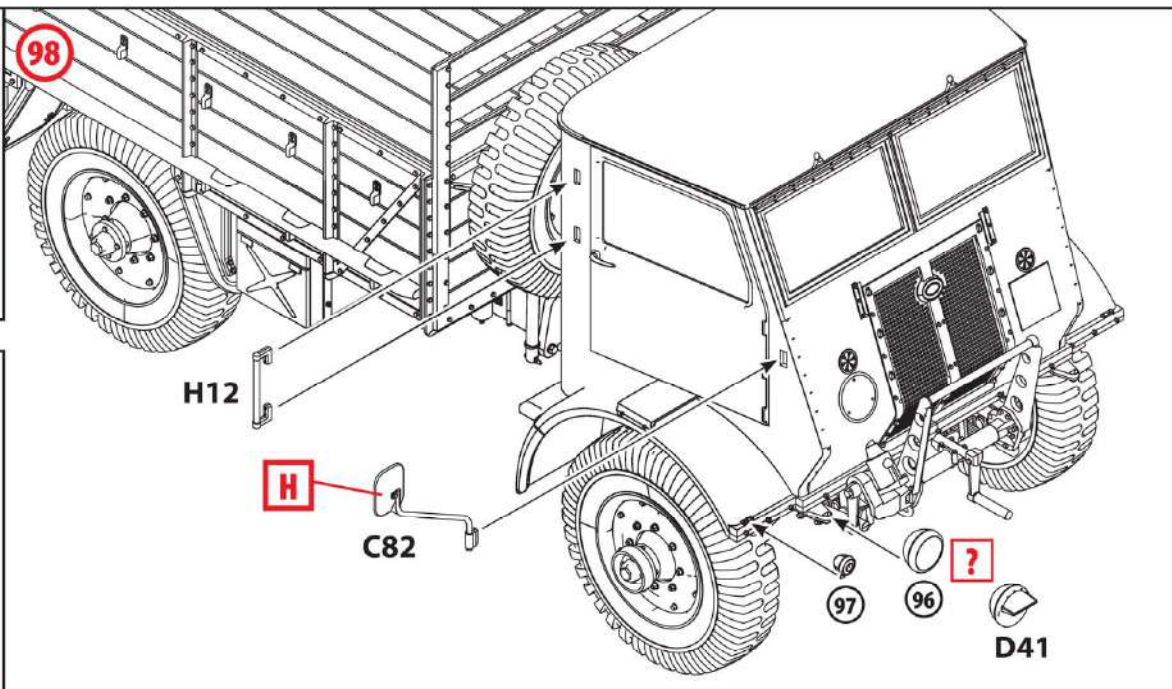
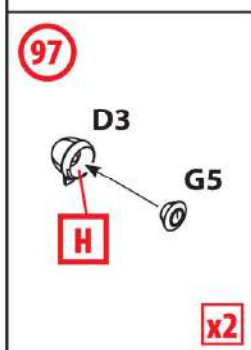
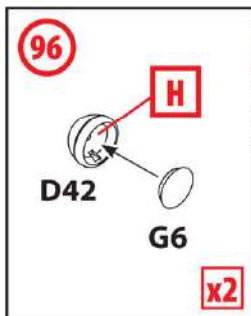
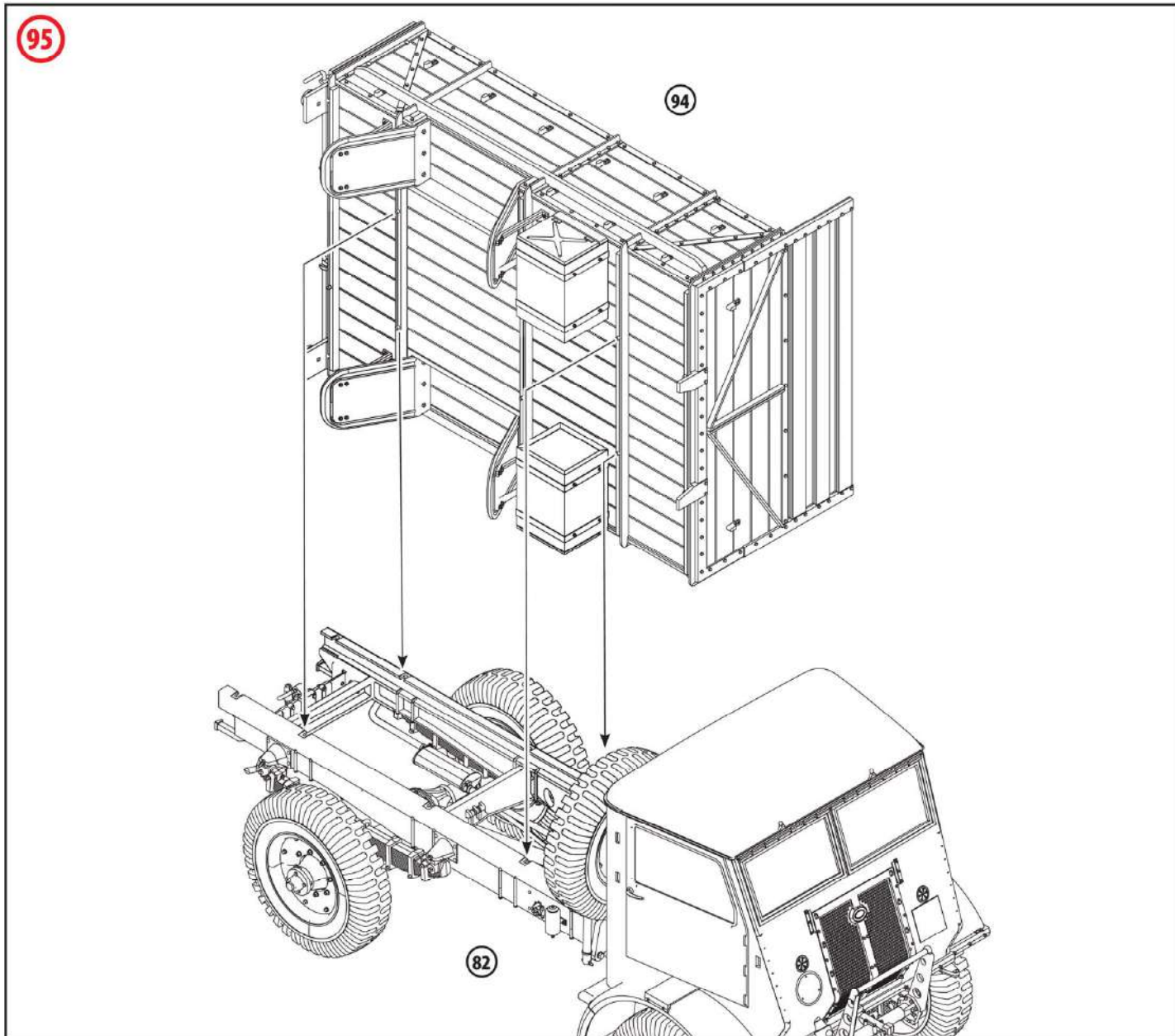

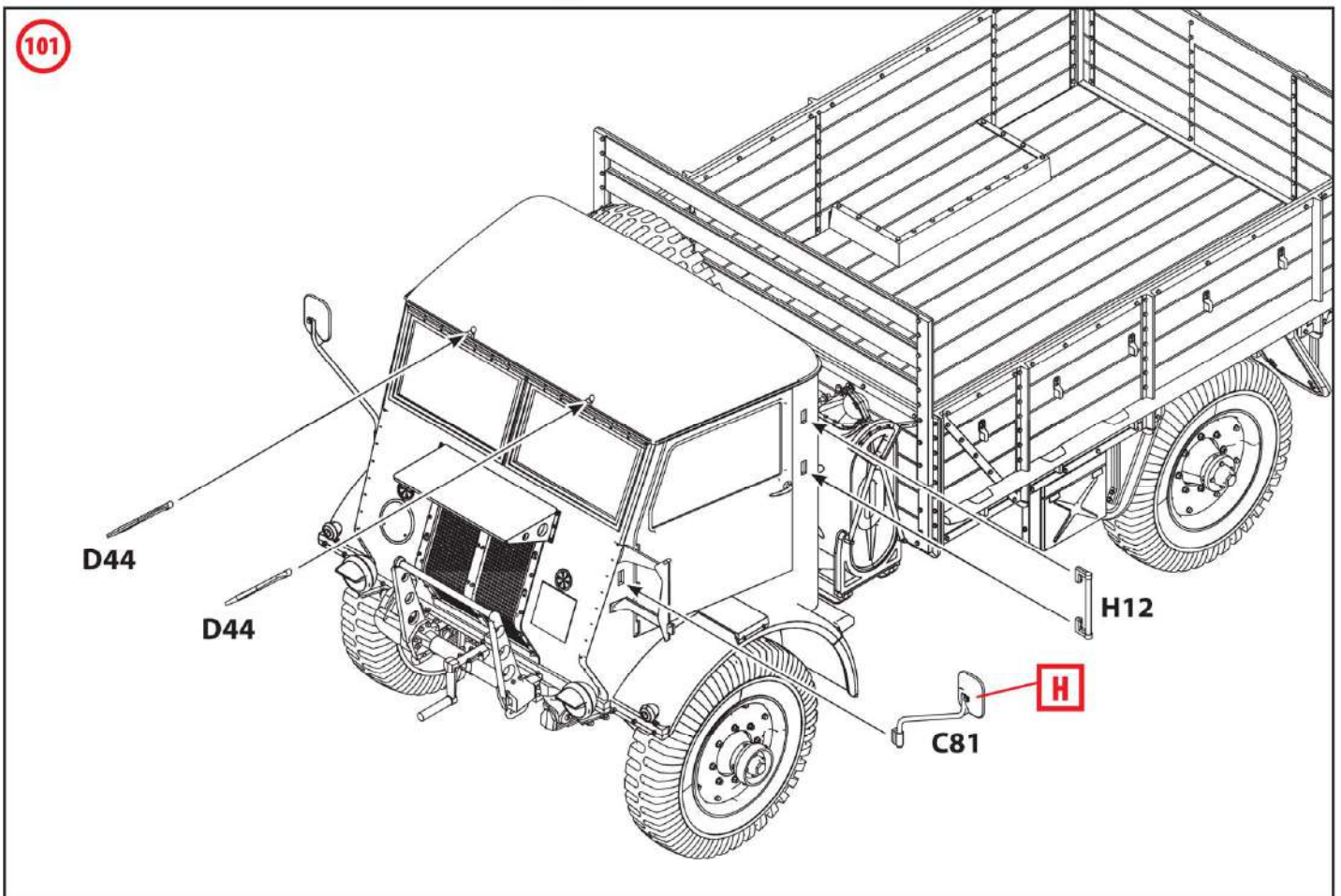
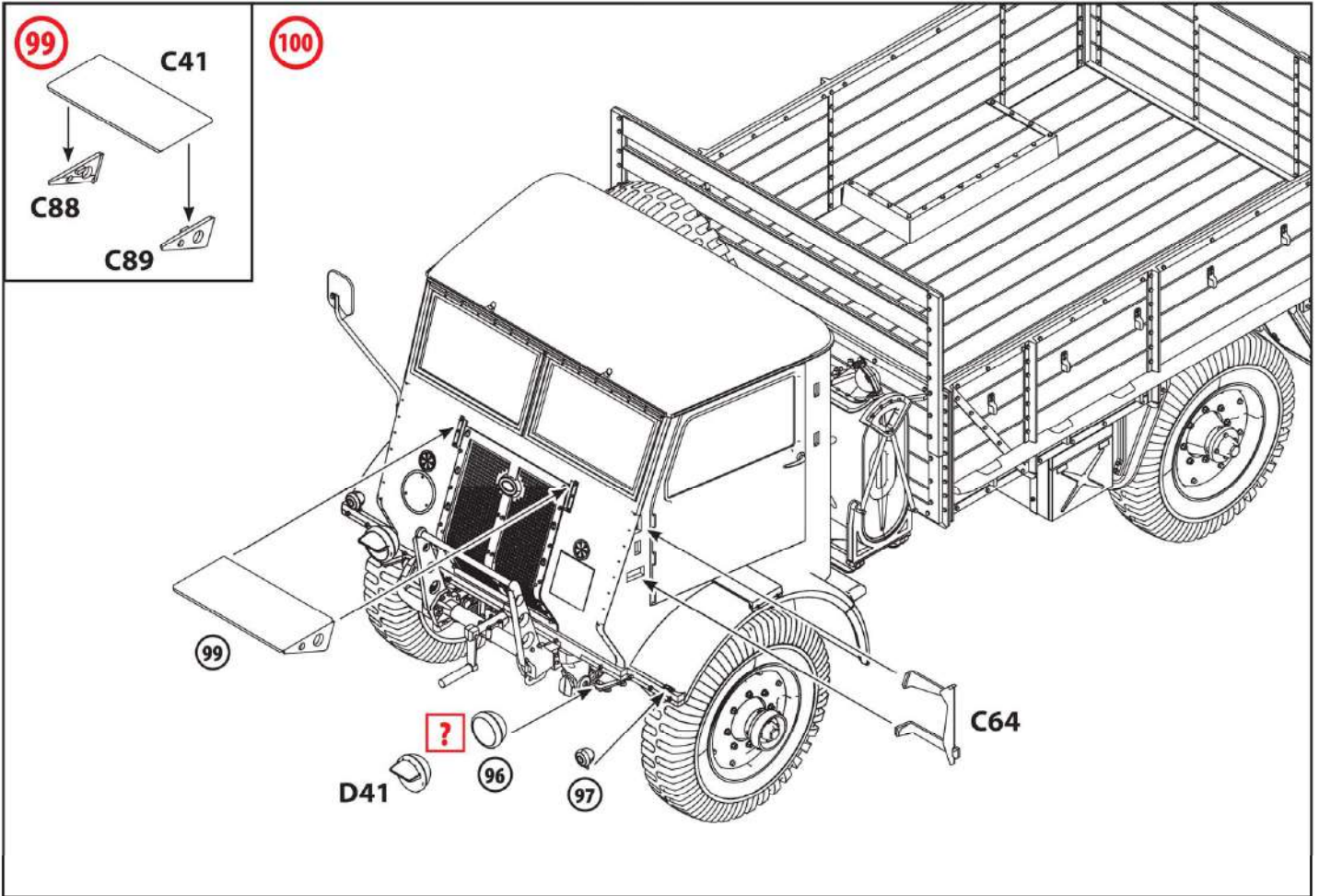

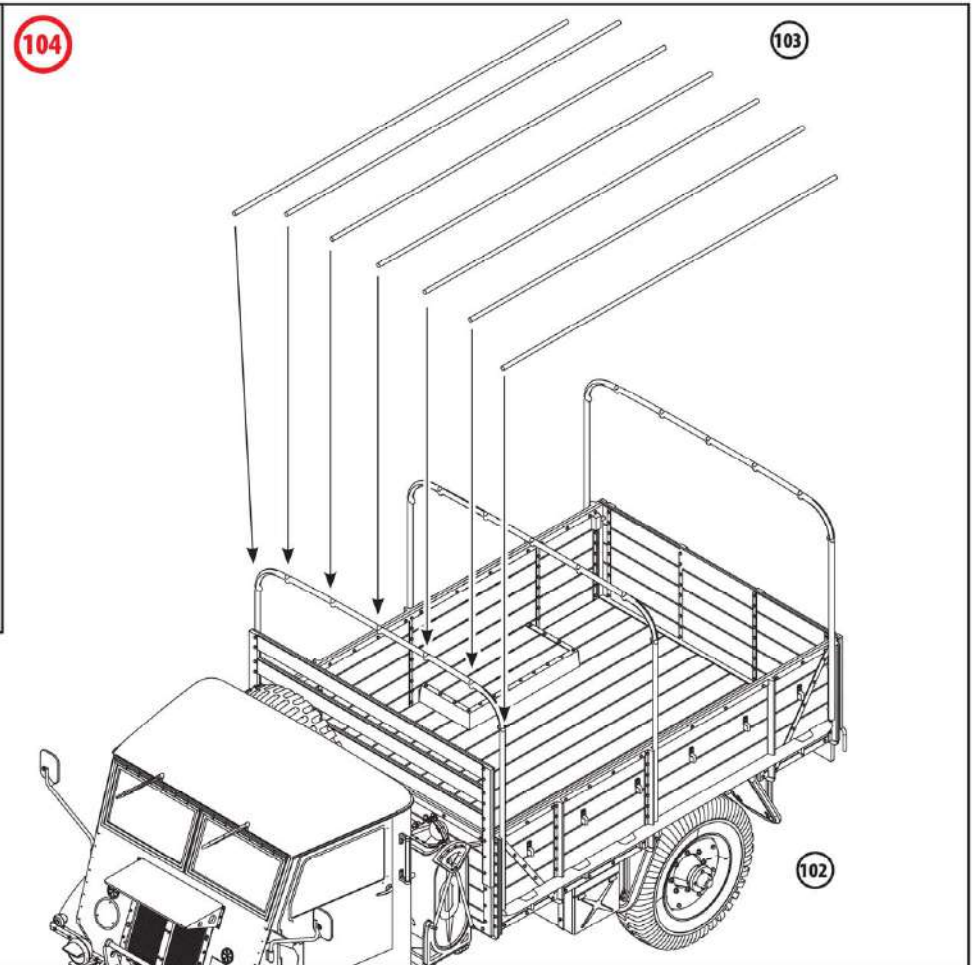
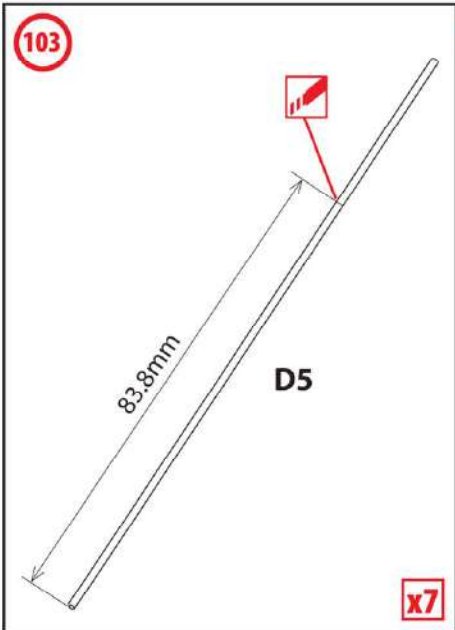
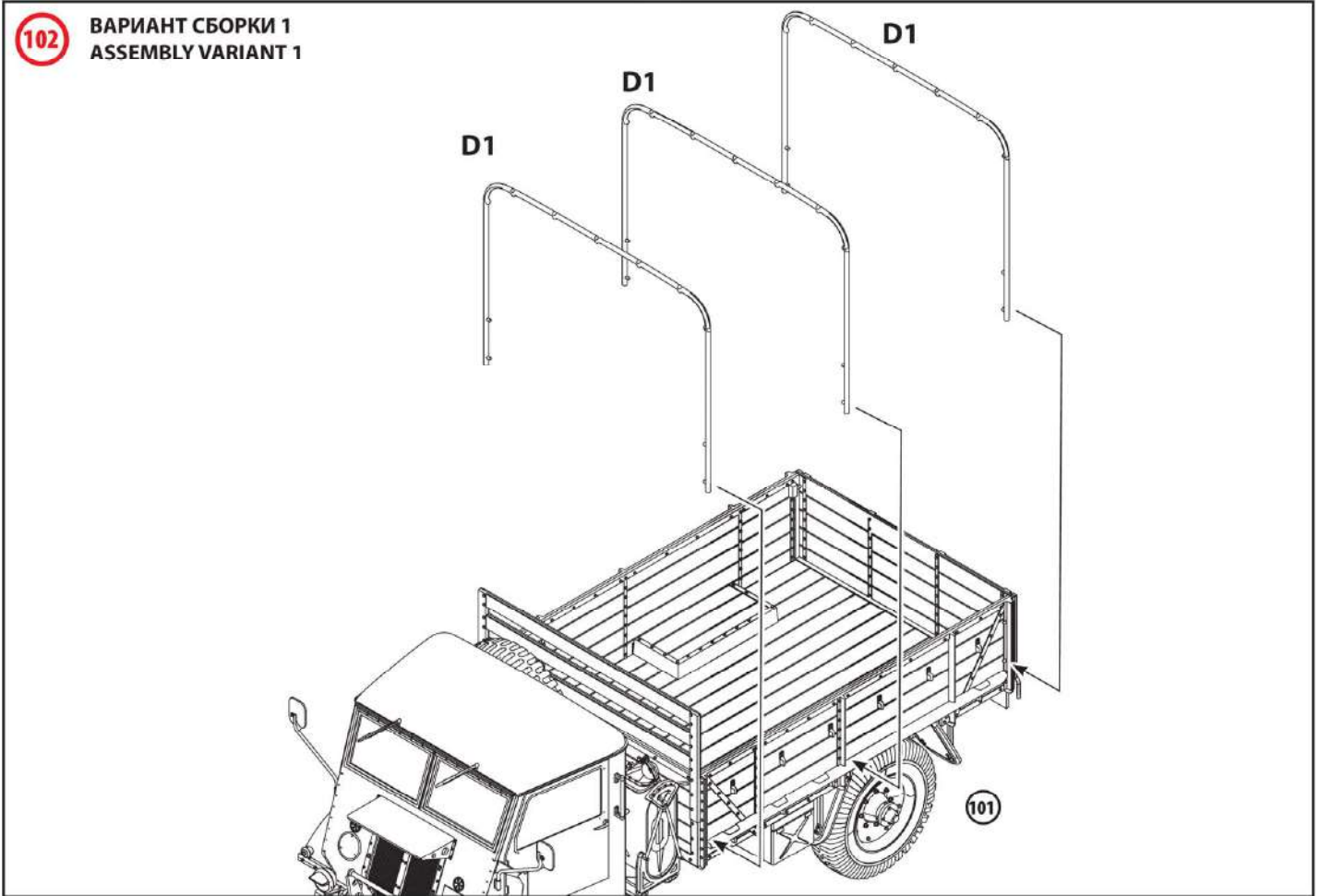

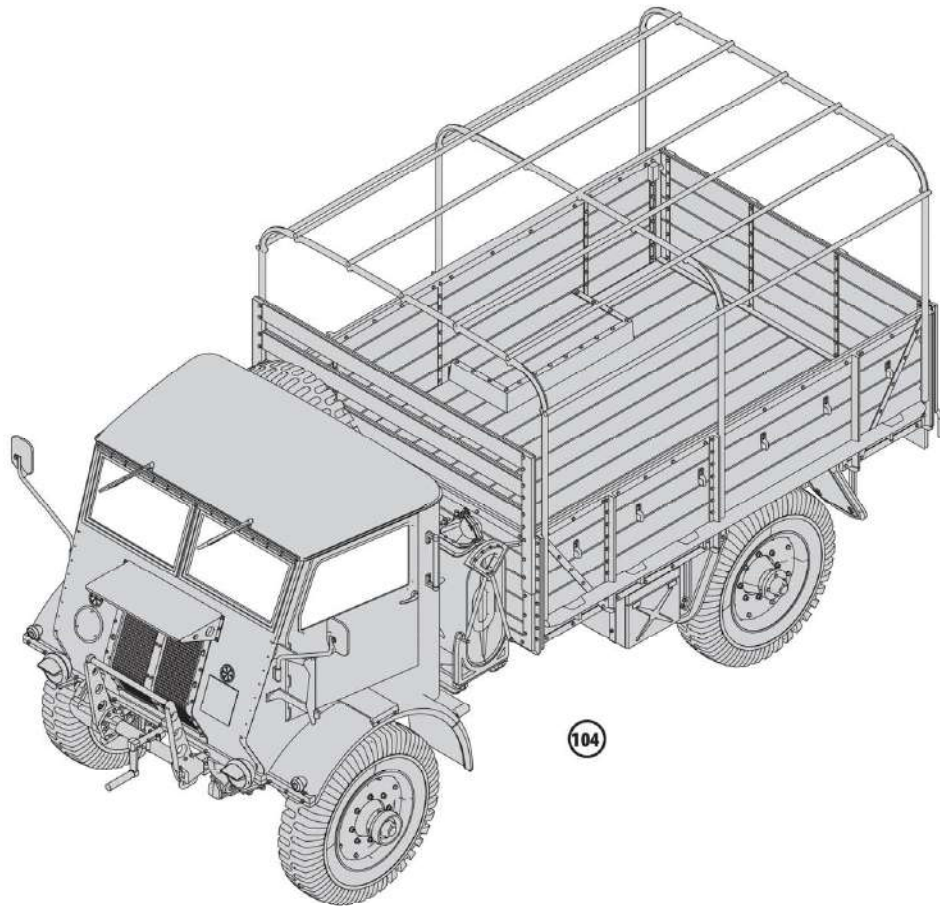

104

105 ВАРИАНТ СБОРКИ 2
 ASSEMBLY VARIANT 2

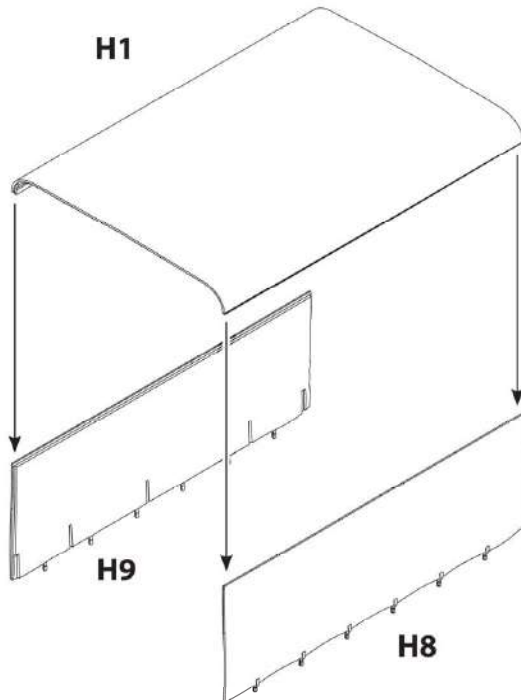

H1

H9

H8

106

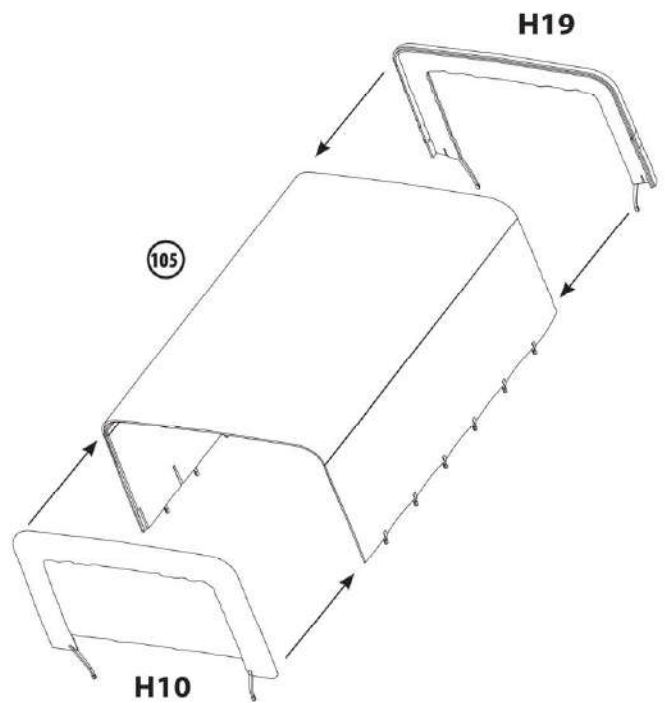

H19

105

H10

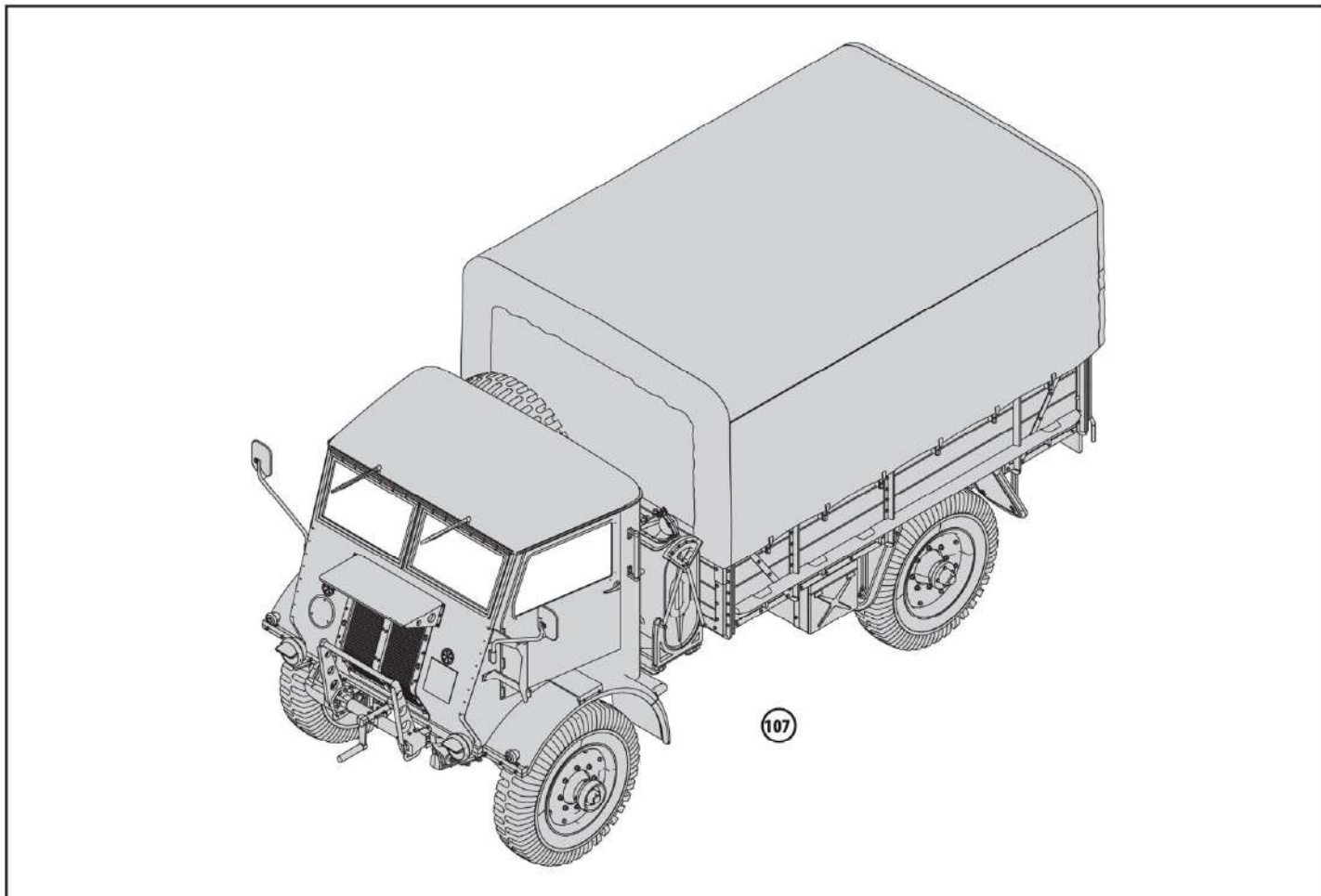
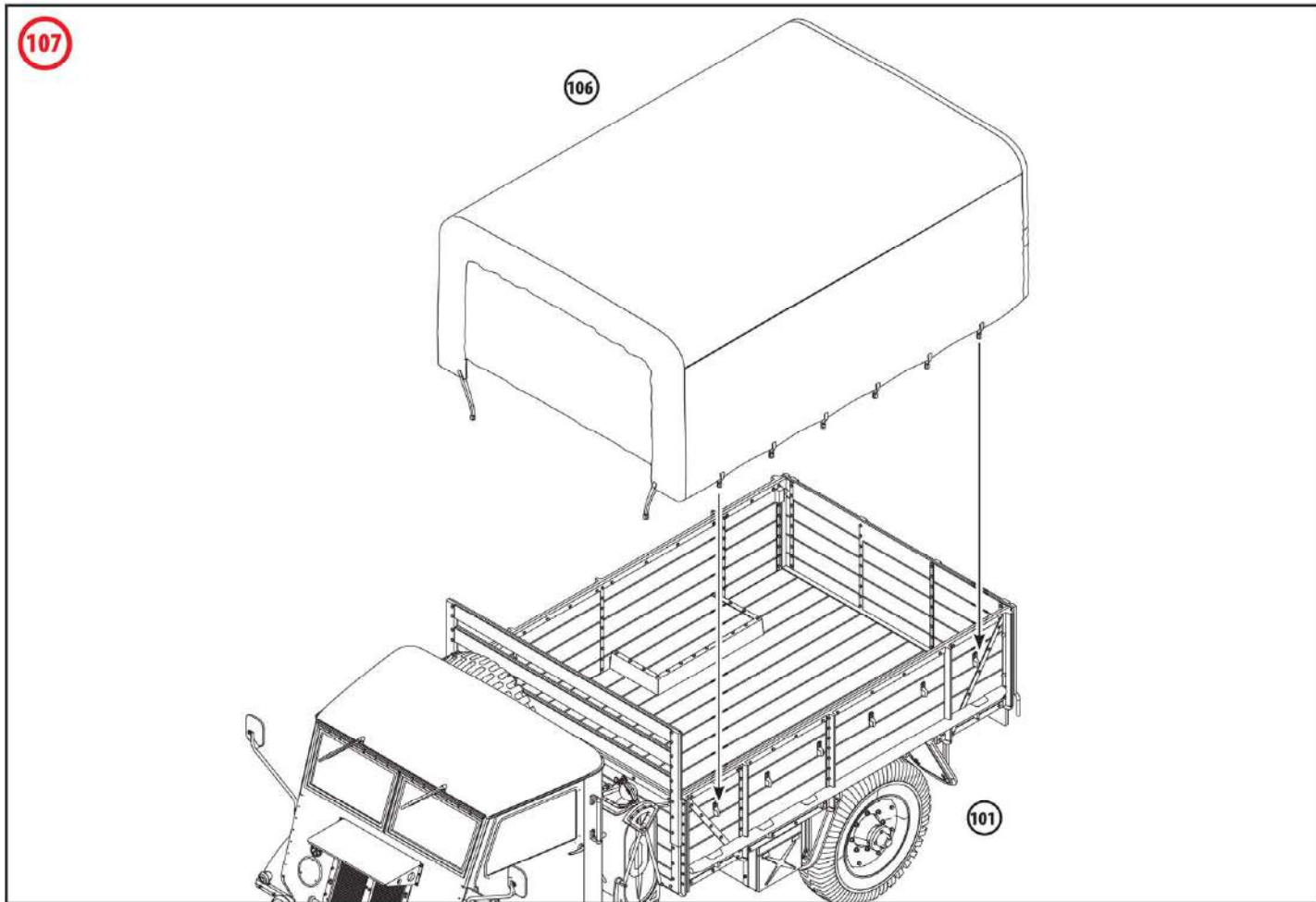

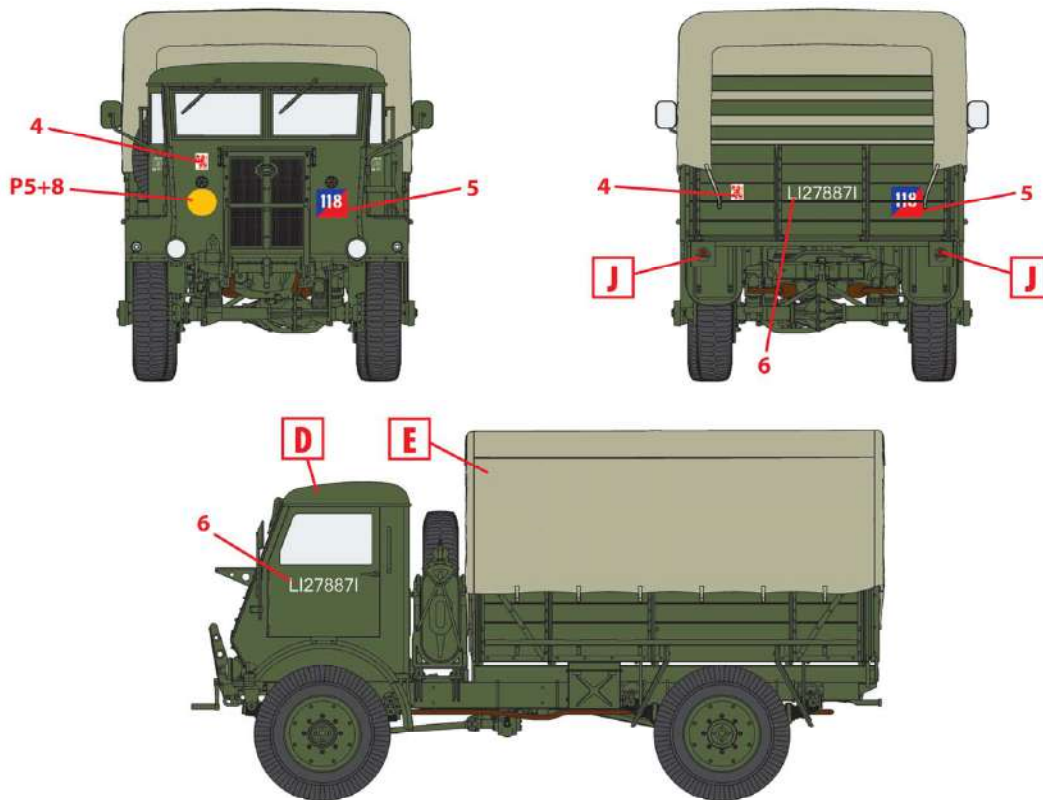

1. W.O.T. 8, 1-я Чехословацкая танковая бригада, Германия, весна 1945 г.
 W.O.T. 8, 1st Czech Armoured Brigade, Germany, Spring 1945

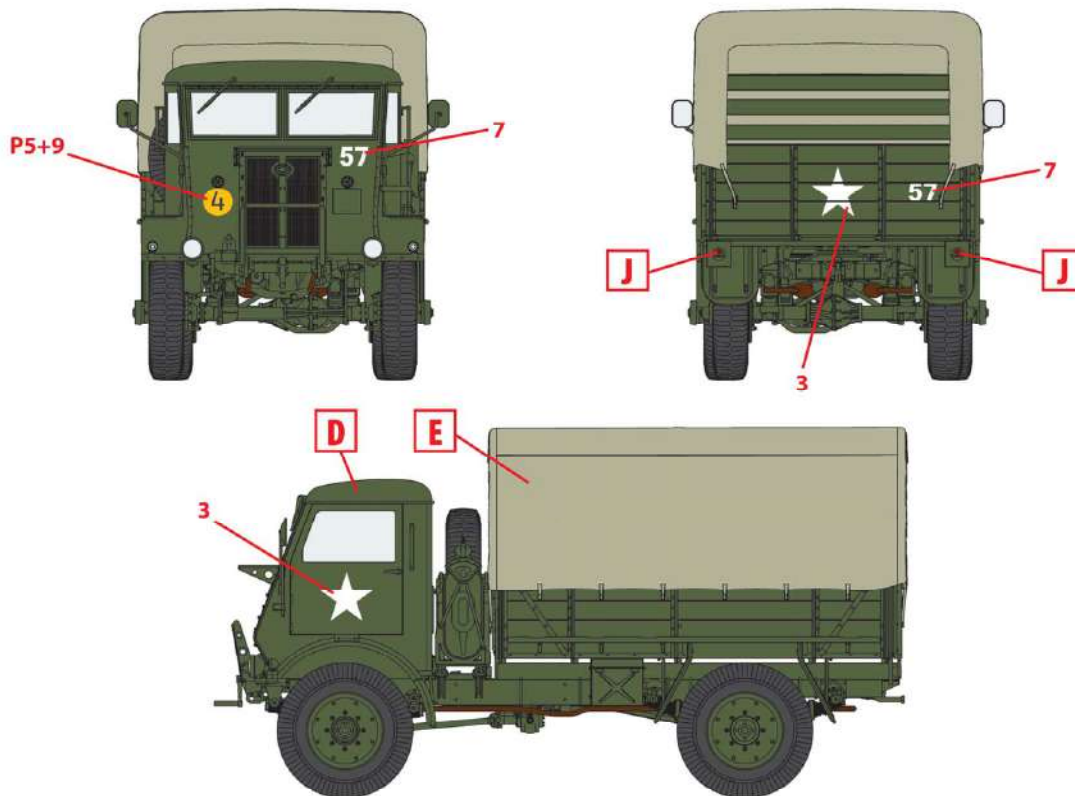

2. W.O.T. 8, Франция, лето 1944 г.
 W.O.T. 8, France, Summer 1944

ООО ICM Холдинг
 ул. Бориспольская 9, строение 64,
 02099, Киев, Украина
 Тел./факс: +38(044) 369 54 12
 E-mail: export@icm.com.ua



ICM Holding
 Borispolskaya, 9, build. 64,
 02099, Kiev, Ukraine
 Tel./Fax: +38(044) 369 54 12
 E-mail: export@icm.com.ua