

AZ model
Plastic kits

Plastic model
scale 1/72

CURTISS HAWK

H-75A1, A2, A3

History in brief

The Curtiss P-36 Hawk, also known as the Curtiss Hawk Model 75, was an American-designed and built fighter aircraft of the 1930s and 40s. A contemporary of both the Hawker Hurricane and Messerschmitt Bf 109, it was one of the first of a new generation of combat aircraft—a sleek monoplane design making extensive use of metal in its construction and powered by a powerful radial engine.

Perhaps best known as the predecessor of the Curtiss P-40 Warhawk, the P-36 saw little combat with the United States Army Air Forces during World War II. It was nevertheless the fighter used most extensively and successfully by the French Armée de l'air during the Battle of France. The P-36 was also ordered by the governments of the Netherlands and Norway, but did not arrive in time to see action before both were occupied by Nazi Germany. The type was also manufactured under license in China, for the Republic of China Air Force, as well as in British India, for the Royal Air Force (RAF) and Royal Indian Air Force (RIAF).

Axis and co-belligerent air forces also made significant use of captured P-36s. Following the fall of France and Norway in 1940, several dozen P-36s were seized by Germany and transferred to Finland; these aircraft saw extensive action with the Ilmavoimat (Air Force) against the Soviet Air Forces. The P-36 was also used by Vichy French air forces in several minor conflicts; in one of these, the Franco-Thai War of 1940–41, P-36s were used by both sides.

From mid-1940, some P-36s en route for France and the Netherlands were diverted to Allied air forces in other parts of the world. The Hawks ordered by the Netherlands were diverted to the Dutch East Indies and later saw action against Japanese forces. French orders were taken up by British Commonwealth air forces, and saw combat with both the South African Air Force (SAAF) against Italian forces in East Africa, and with the RAF over Burma. Within the Commonwealth, the type was usually referred to as the Curtiss Mohawk.

With around 1,000 aircraft built by Curtiss itself, the P-36 was a major commercial success for the company. It also became the basis not only of the P-40, but two other, unsuccessful prototypes: the Y P-37 and the XP-42.

Read before you start:

- 1/ Before you begin, study carefully instructions, exploded drawings and numbering of parts.
- 2/ Prior your assembly, choose carefully your variant, and remove all parts of it.
- 3/ Optional parts and theirs application compare with the picture on the box.
- 4/ Carefully remove parts, clean its and prior to applying adhesive, check to see whether the parts fit together.
- 5/ Assemble thoroughly, do not hurry. You will find that your finished model will reflect your time, work and patience.

Doporučení a upozornění:

- 1/ Dříve než začnete ,prostudujte stavební návod a číslování dílů.
- 2/ Před začátkem stavby zvolte verzi a pečlivě vyberte díly pro variantu, kterou chcete stavět .
- 3/ Volitelné díly/možnosti a jejich použití při stavbě konfrontujte s náhledem markingu na obalu.
- 4/ Díly opatrně oddělte z rámečků, odstraňte technologické vtoky a před slepením je řádně začistěte.
- 5/ Pracujte pečlivě, nespěchejte, dokonalý vzhled modelu záleží jen na Vás.

Symbols/Symboly

Drill hole



Vyvrtat

Cyanoacrylate



Vteřinové lepidlo

Remove



Odstranit

Reduce



Zbrousit

Make new



Vyrobít

Option



Volba

Bend



Ohnout

Putty



Tmel

	Colour name	Humbrol		Colour name	Humbrol
A	Black	H33	F	Aluminium	H56
B	White	H34	G	Silver	H11
C	Interior Green	H226	H	Chrome	H191
D	Gunmetal	H53	I	Tyre	H85
E	Leather	H62	J	Rust	H113

Drawings/Výkresy:
Internet

References/Podklady
Internet

Plastic parts

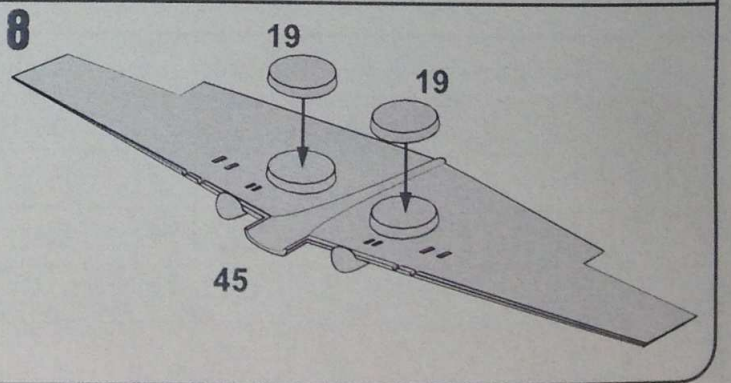
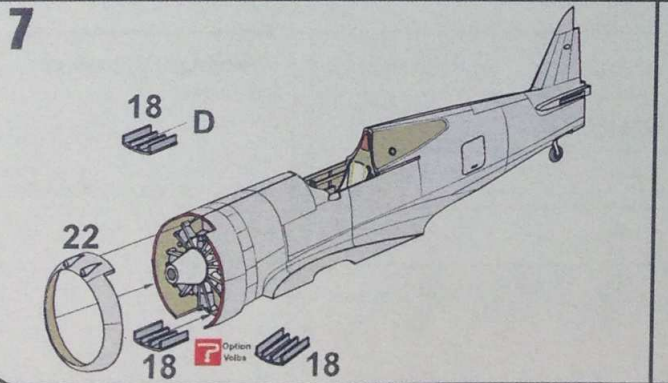
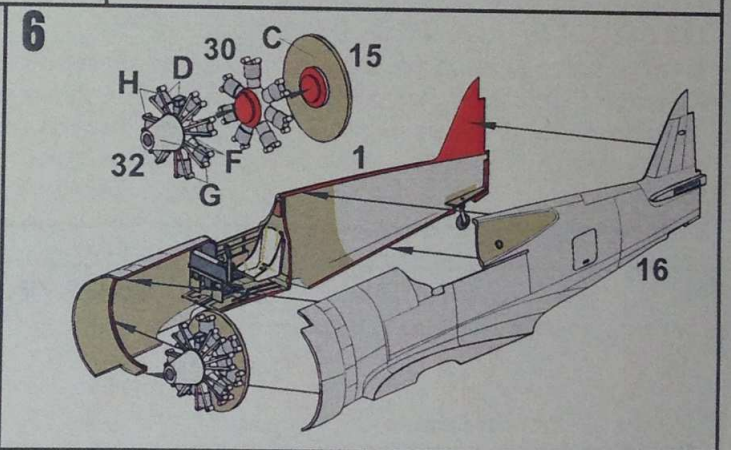
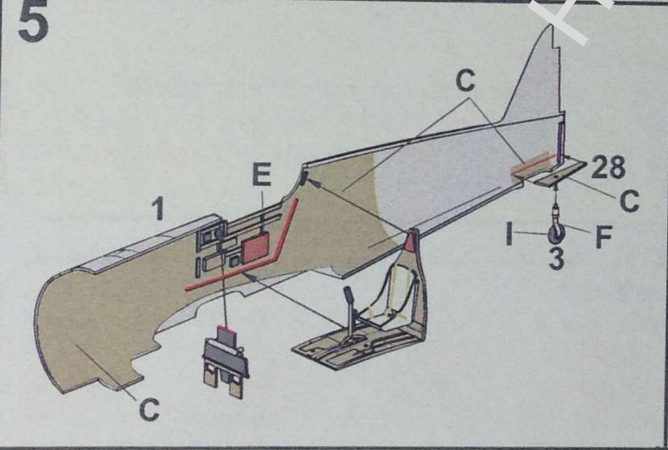
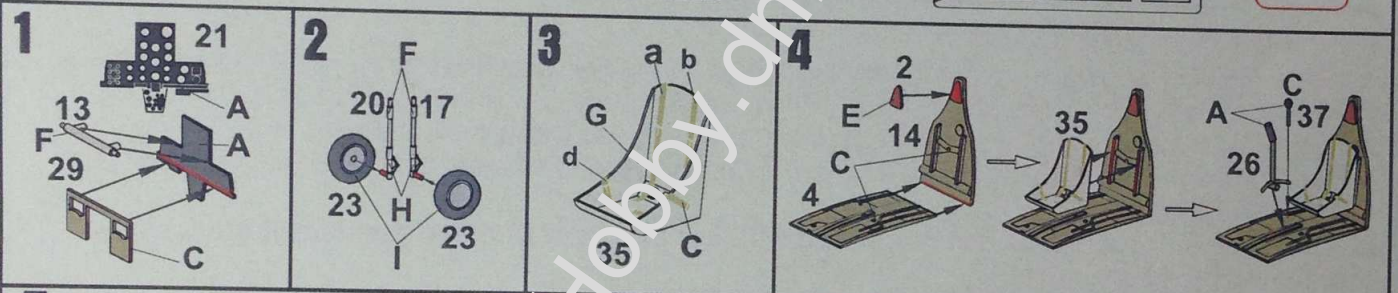
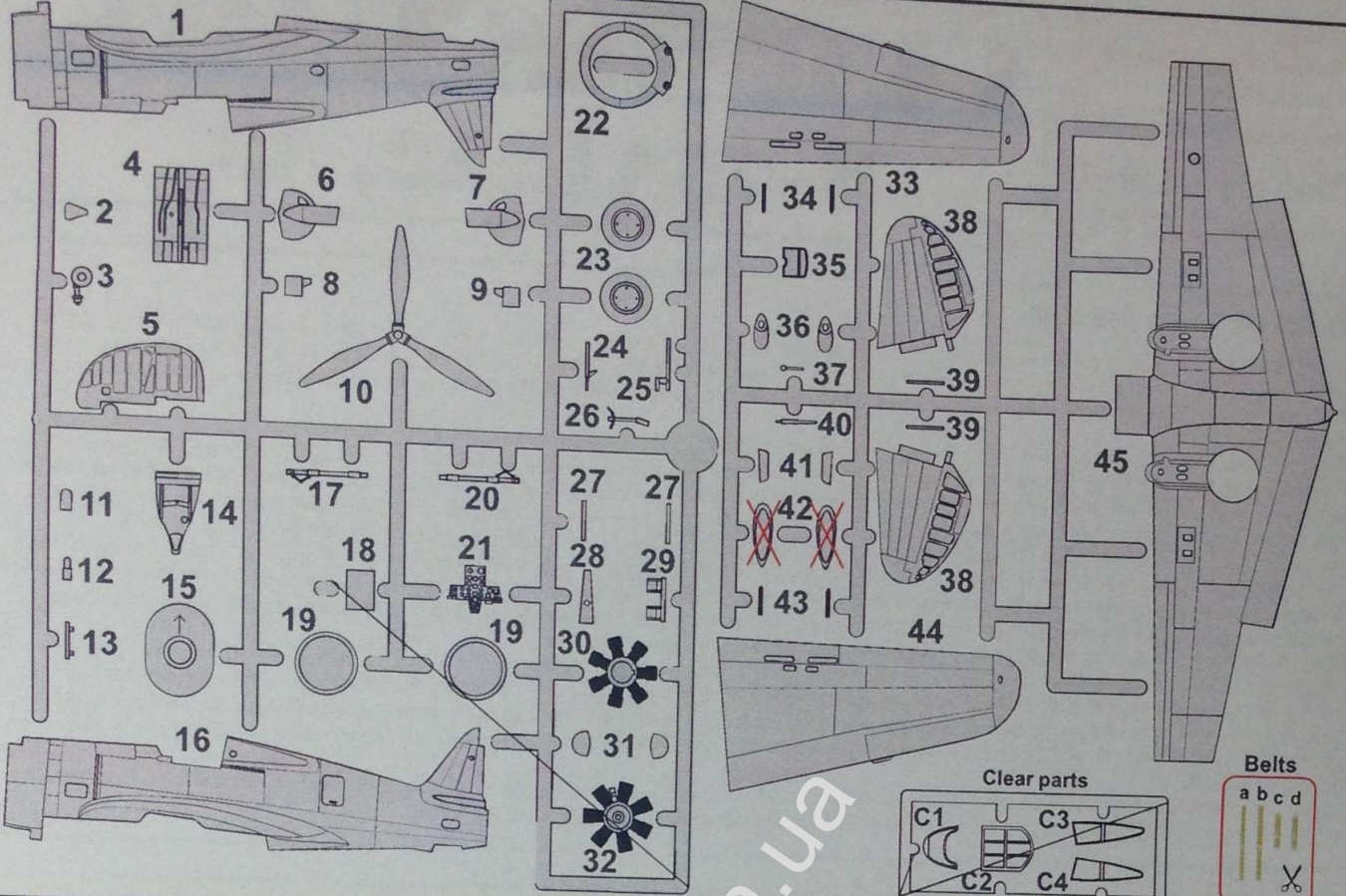

H-75A-2, A-3

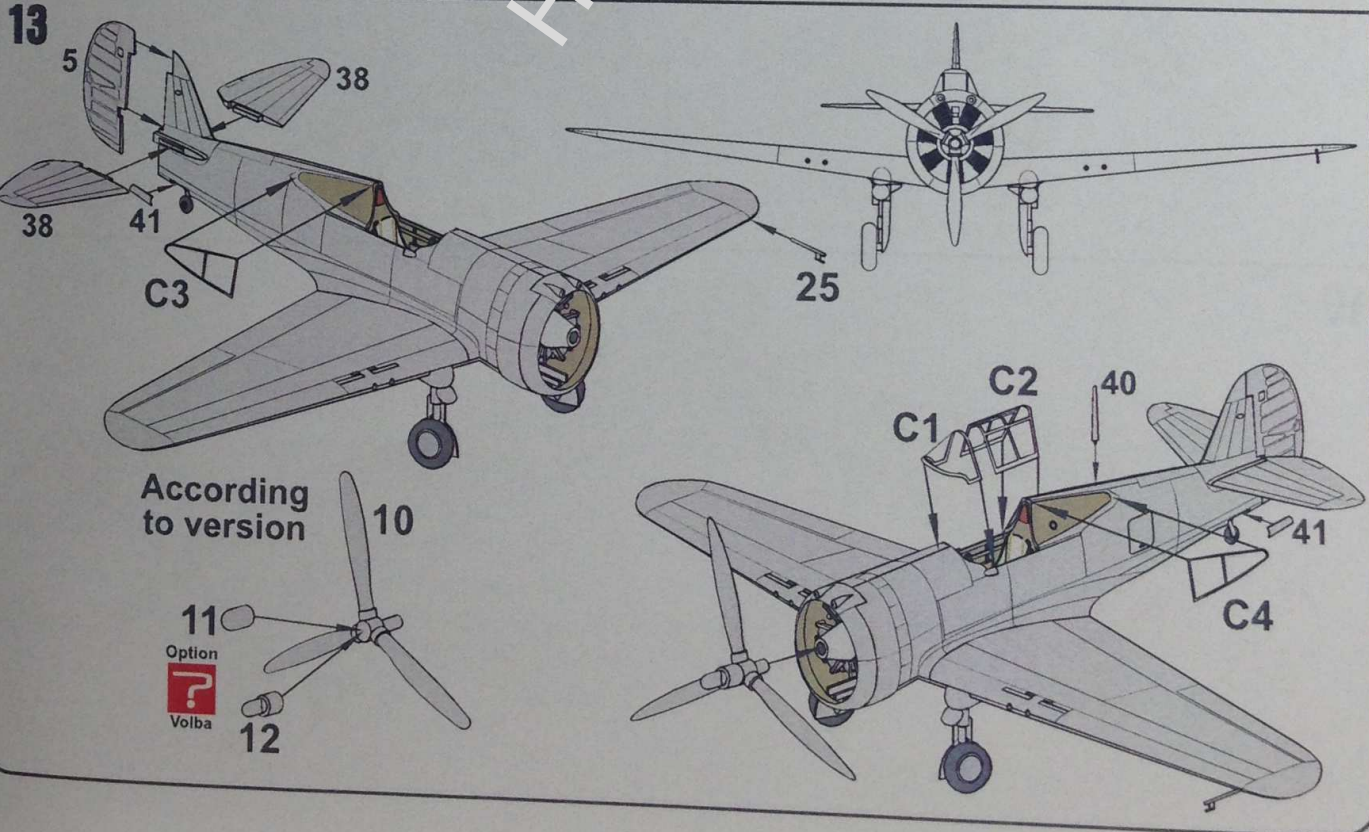
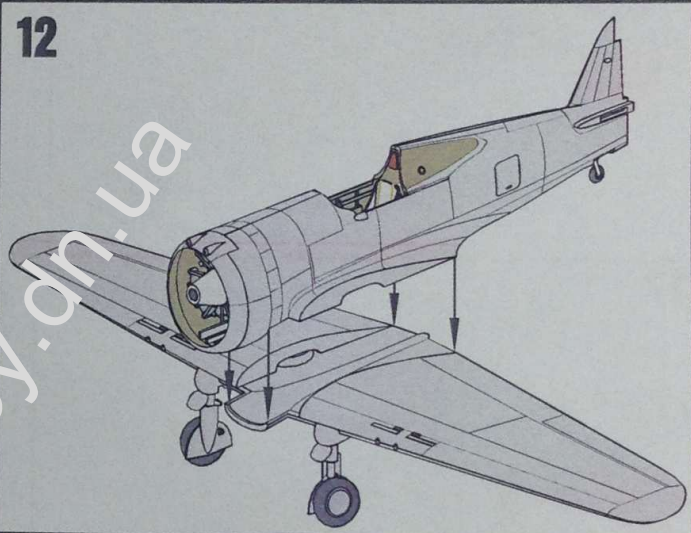
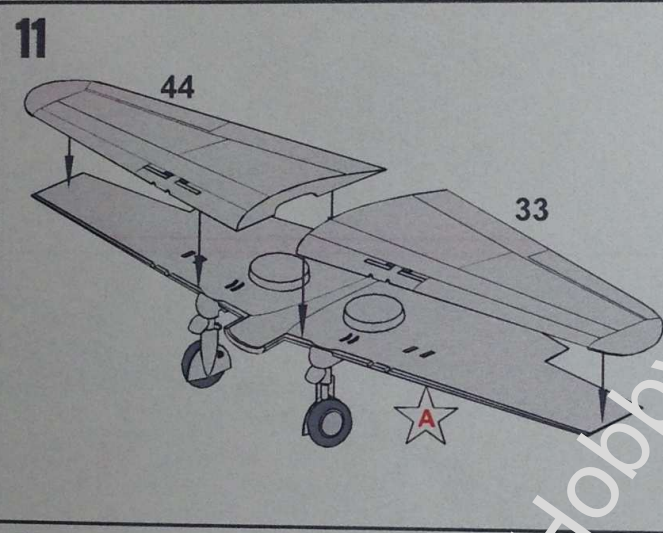
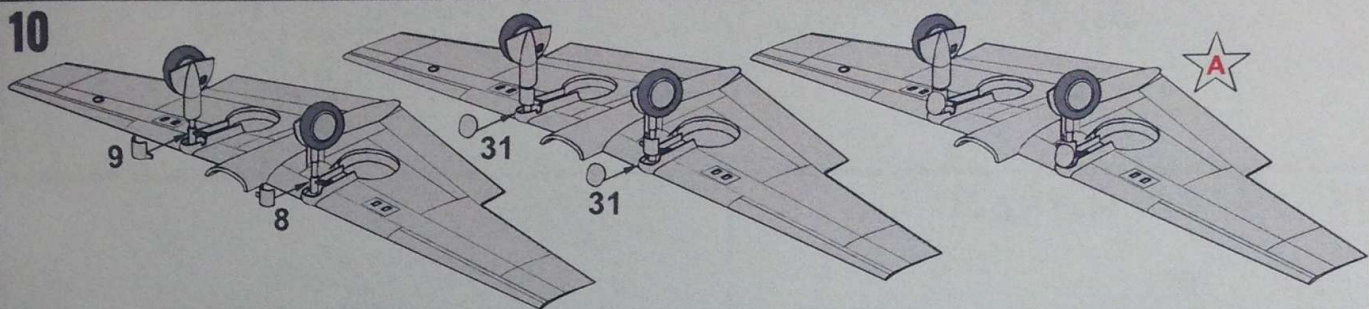
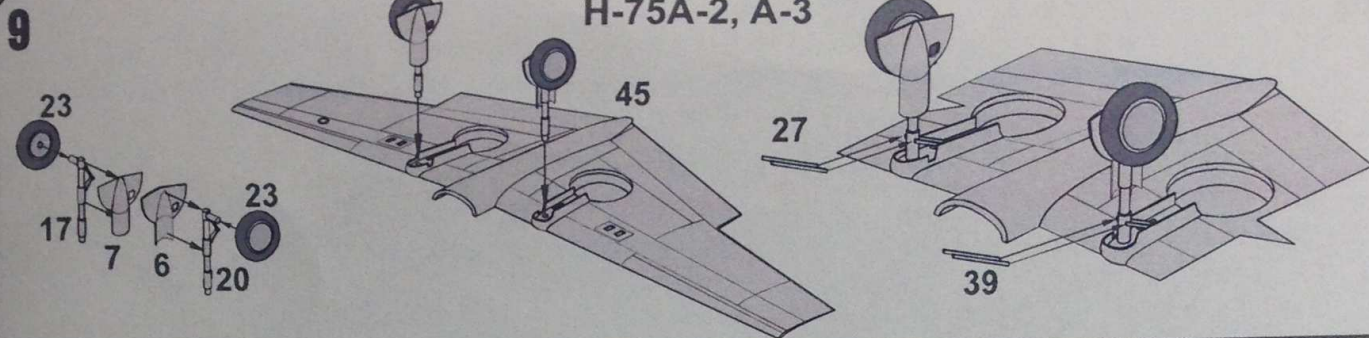

14

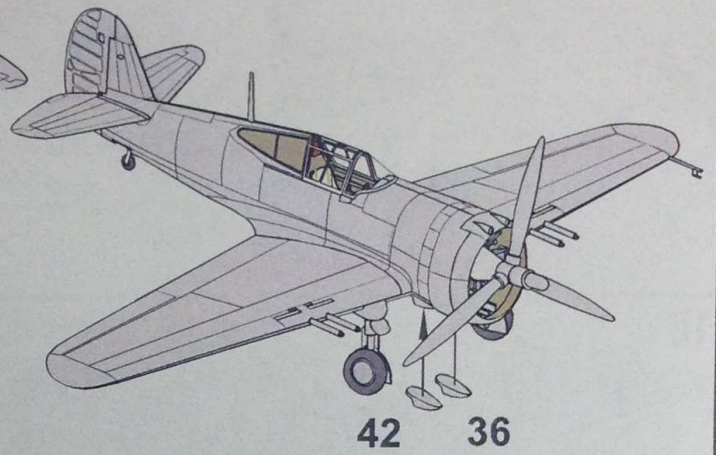
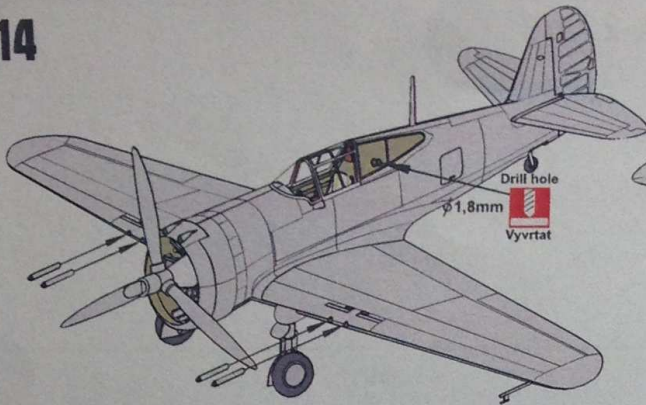

42 36

15

H-75A-1

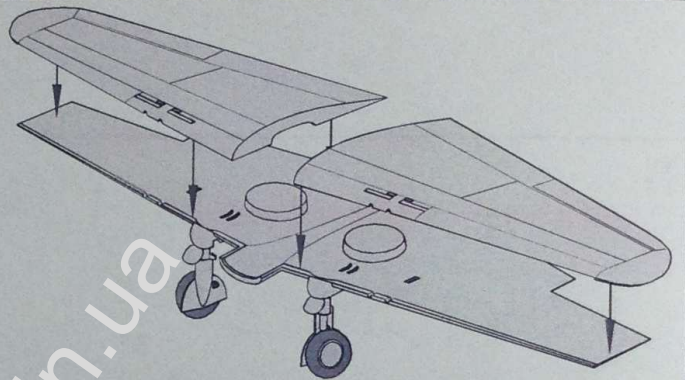
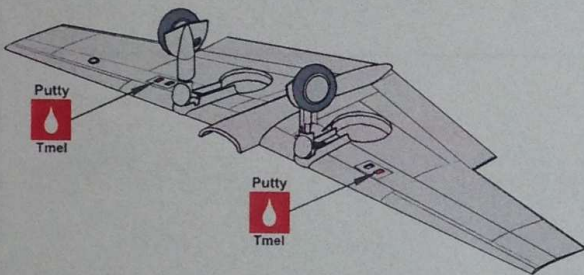

17

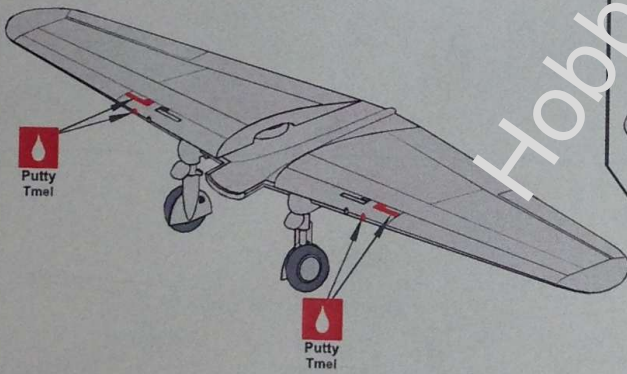

18

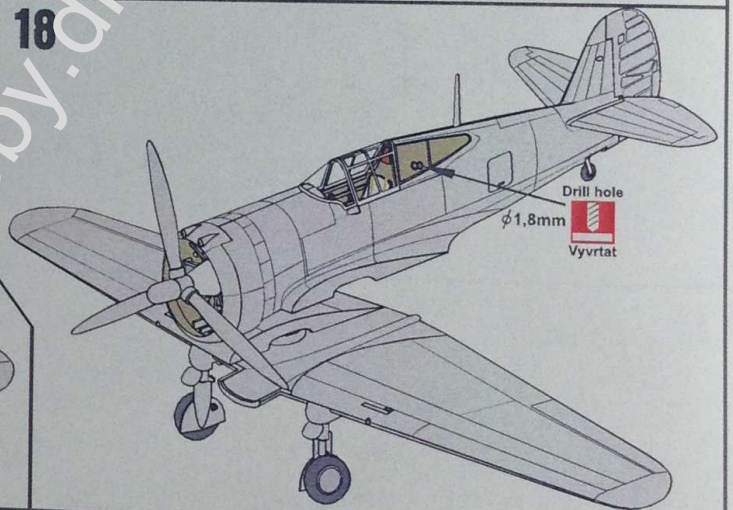

19

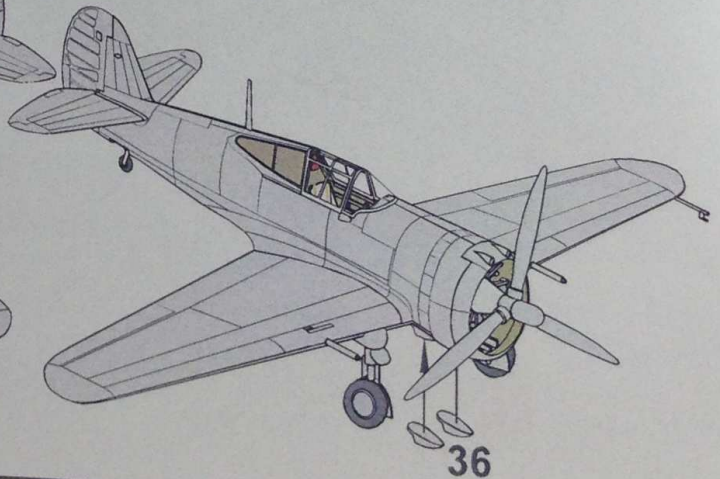
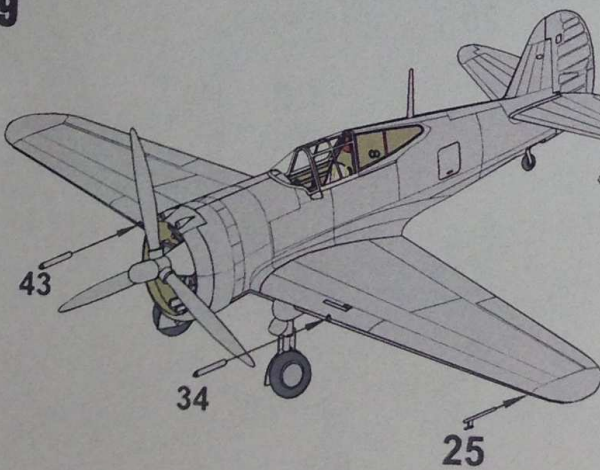

36

Hobby.dn.ua