



P-51H

CAT.NO 4817



SCALE
1:48

РОЗМІХ КРИЛА \ SPAN: 235 мм \ mm
ДОВЖИНА \ LENGTH: 212 мм \ mm
КІЛЬКІСТЬ ДЕТАЛЕЙ \ PARTS: 203 шт \ pieces

ЗБІРНА МОДЕЛЬ \ ЛІМІТОВАНИЙ ВИПУСК
PLASTIC MODEL KIT \ LIMITED EDITION

UA "Mustang" P-51H - найшвидший поршневий винищувач з усіх варіантів "Mustang". P-51H був створений на базі експериментальної версії XP-51F1G з двигуном Packard Merlin V 1659-9. Двигун розвивав короткочасну потужність 2000 к.с.

Основні відмінності від попередніх версій "Mustang": збільшена висота фюзеляжу, збільшилася хвостова частина фюзеляжу; зменшився повітрязбірник карбюратора; спрощено шасі з колесами меншого діаметру; літак отримав крило з прямою передньою кромкою; дещо відрізнявся літкар кабіни пілота; озброєння складалося з шести 12,7 мм кулеметів.

Перший P-51H-1-NA підняли в повітря 3 лютого 1945 р. Перша серія складалася з 29 машин. Всього було замовлено 2000 машин, з них 555 як перша модифікація.

Один P-51H передали RAF для проведення оціночних випробувань в Boscombe Down. Спрійний номер RAF KN987.

Розробка завершилася надто пізно для участі у війні в Європі. Тільки влітку 1945 року P-51H отримали кілька частин USAAF. Жоден літак не встиг взяти участь в бою і в війні на Тихому океані. Було виготовлено 555 P-51H і всі замовлення були скасовані. Пілоти вважали P-51H набагато легше і простіше в управлінні, ніж P-51D, але деякі пілоти воліли літати на P-51D. Саме з цієї причини P-51H не розглядався для участі в бойових діях в Кореї.

EN P-51H was the fastest piston engine fighter among all "Mustang" versions. It was developed from XP-51F and XP-51G experimental aircrafts, powered by Packard Merlin V-1659-9 engine (2000 hp).

Main design differences to the early "Mustang" versions were: increased fin height, increased rear fuselage section, increased cross section of carburetor air intake, simplified chassis with smaller wheels, smaller fuel tanks, minor changes in cockpit construction, armament - six 12.7mm wing machine guns.

First modification, named P-51H-1-NA made its maiden flight on 1st Feb, 1945. In total, around 2000 aircrafts had been ordered, 555 of them - from the 1st modification.

One P-51H was provided to RAF in order to conduct own flight tests in Boscombe Down. The plane received reg. number RAF KN987.

P-51H was developed too late to be sent on the European front line, although some P-51Hs were issued to operational units, none saw combat in World War II, and in postwar service, most were issued to reserve units. Serial number 44-64130 was designated BuNo 09064 and used by the U.S. Navy to test transonic airfoil designs and then returned to the Air National Guard in 1952. The P-51H was not used for combat in the Korean War despite its improved handling characteristics, since the P-51D was available in much larger numbers and was a proven commodity.

ПОСИЛАННЯ НА ЦІКОРИ \ REQUIRED PAINTS

A Mr.Color C8 AK Xtr.Met.- AK481 Polished Aluminium	B Mr.Color C351 AK RC262 Interior Green	C Mr.Color C33 AK RC001 Flat Black	D Mr.Color C329 AK RC008 Orange Yellow	E Mr.Color C326 AK RC258 Insignia Blue	F Mr.Color C327 AK RC006 Red	G Mr.Color C12 AK RC259 Olive Drab	H Mr.Met.Color MC213 AK Xtr.Met.- AK476 Steel
I Mr.Color C331 AK RC296 Sea Grey	J Mr.Color C325 AK RC220 Light Grey	K Mr.Color C368 AK RC290 RAF Sky	L Mr.Met.Color MC211 AK Xtr.Met.- AK477 Chrom Silver	M Mr.Met.Color MC218 AK Xtr.Met.- AK479 Aluminium	N Mr.Color C138 AK RC505 Clear Green	O Mr.Color C48 AK RC507 Clear Yellow	P Mr.Color C45 AK RC046 Ivory
Q Mr.Color C41 AK RC067 Red Brown	R Mr.Color C352 AK RC263 Chromate Yellow	S Mr.Color C47 AK RC503 Clear Red	T Mr.Color C44 AK RC079 Tan	U Mr.Met.Color MC214 AK Xtr.Met.- AK483 Gun Metal	V Mr.Color C137 AK RC022 Rubber Black		

УМОВНІ СИМВОЛИ \ USED SYMBOLS

1 ЕТАПИ ЗБИРАННЯ STAGES OF ASSEMBLY	A1 НОМЕР ДЕТАЛІ PART NUMBER	1 ОКРЕМІ ДЕТАЛІ SEPARATE DETAILS	1 НАКЛЕЇТИ ДЕКАЛІ APPLY DECALS	1 НАКЛЕЇТИ МАСКУ APPLY THE ADHESIVE MASK	? НА ВИБІР OPTIONAL
A ВАРИАНТИ ДЛЯ ЗБИРАННЯ VARIANTS OF ASSEMBLY	S КЛЕЇТИ НА СУПЕРКЛЕЙ GLUE ON "SUPER GLUE"	X НЕ КЛЕЇТИ DON'T GLUE	○ ЗРОБИТИ ОТВІР MAKE A HOLE	△ ВІДРІЗАТИ НОЖЕМ DETACH WITH KNIFE	A ФАРБУВАТИ TO PAINT

Модель вироблена за технологією «short run» і призначена для досвідчених моделістів

This model is produced using short run technology, designed for experienced modelers



КОМПЛЕКТНІСТЬ / COMPLETE SET

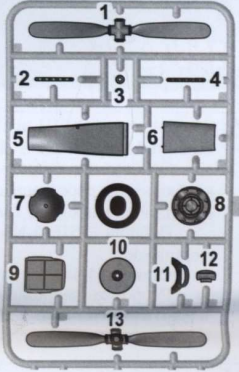
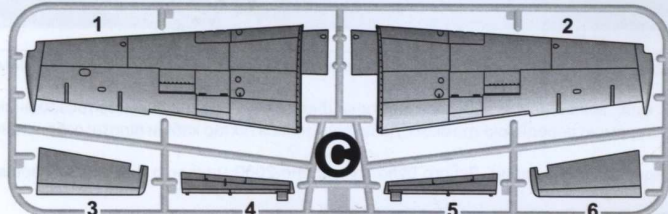
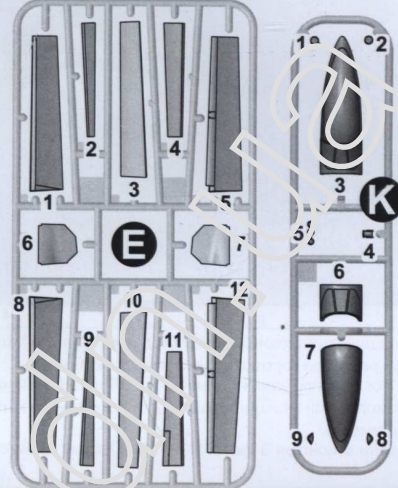
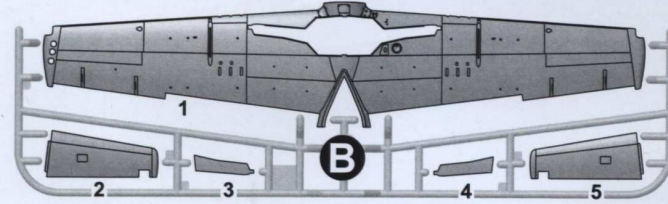
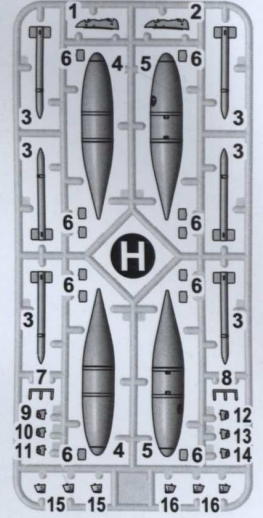
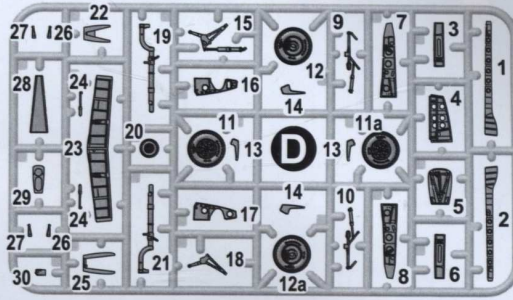
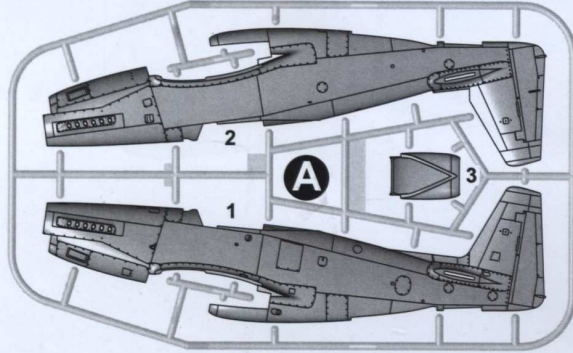

ДВІ ДЕКАЛИ ДЛЯ ЧОТИРЬОХ ВАРІАНТІВ ЗАБАРВЛЕННЯ
TWO DECALS FOR FOUR VERSIONS OF COLOURING

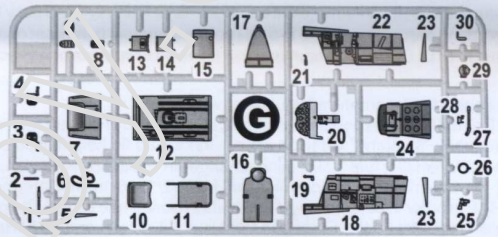
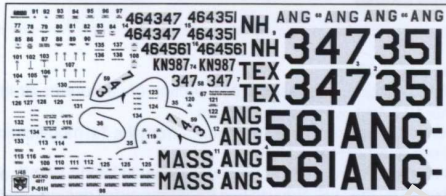

МАСКИ ДЛЯ ФАРБУВАННЯ
MASKS FOR PAINTING

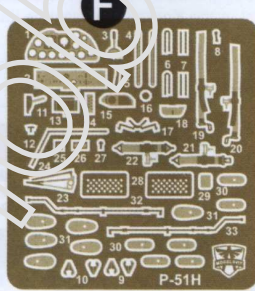
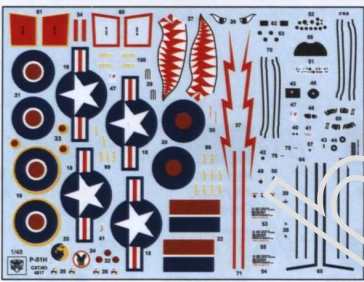

ФОТОЕТЧ ДЛЯ ЗБИРАННЯ
МОДЕЛІ
PHOTO-ETCHED SHEET
FOR ASSEMBLY OF MODEL

ПЛІВКА З ПРОЗОРИМИ
ДЕТАЛЯМИ
FILM WITH TRANSPARENT
DETAILS

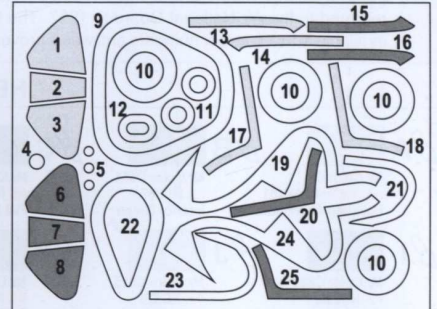
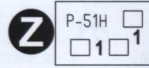

ЗОВНІ OUTSIDE
ВСЕРЕДИНІ INSIDE





СХЕМА ЗБИРАННЯ / THE SCHEME OF ASSEMBLY



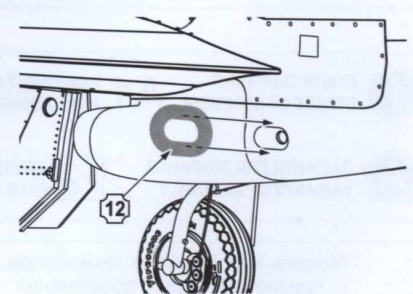
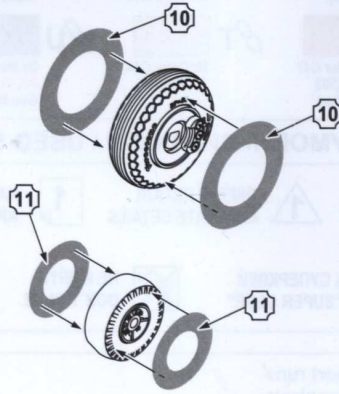
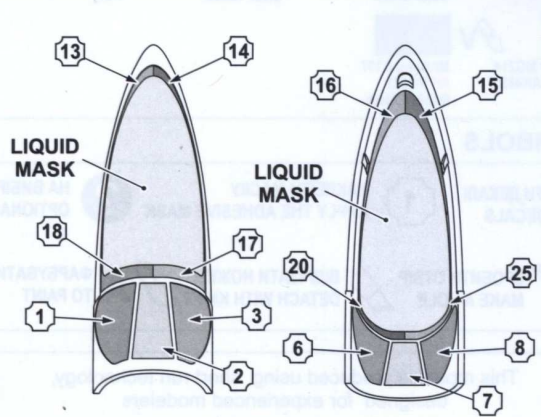

СХЕМА ЗБИРАННЯ / THE SCHEME OF ASSEMBLY



for flap down position

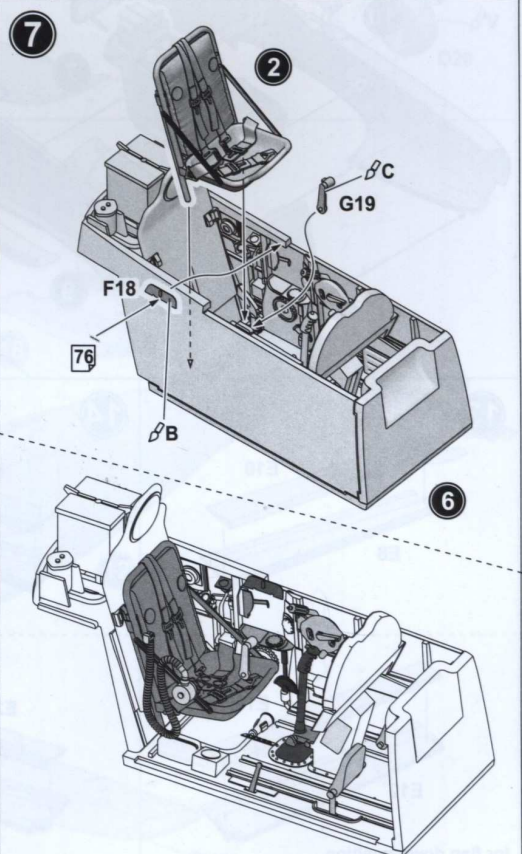
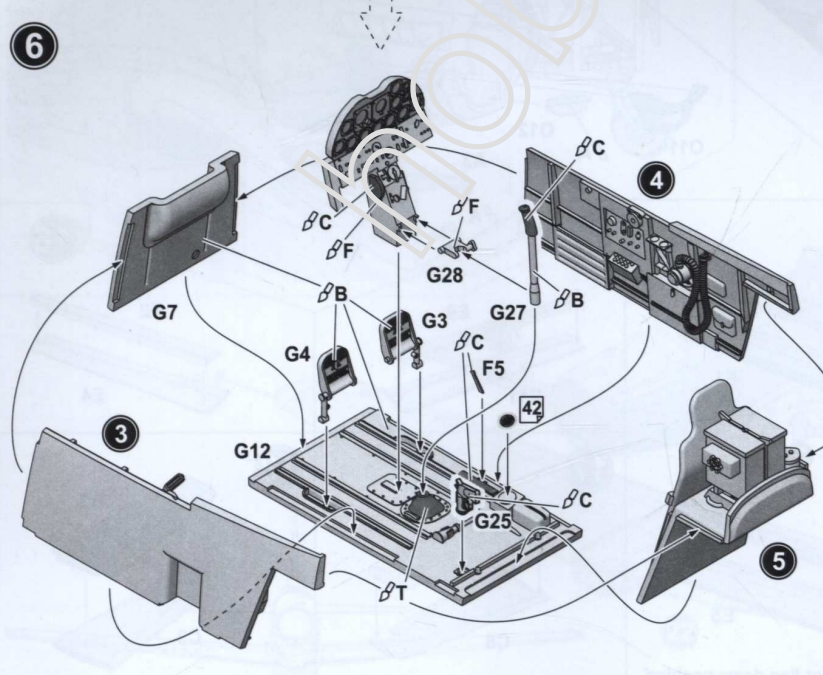
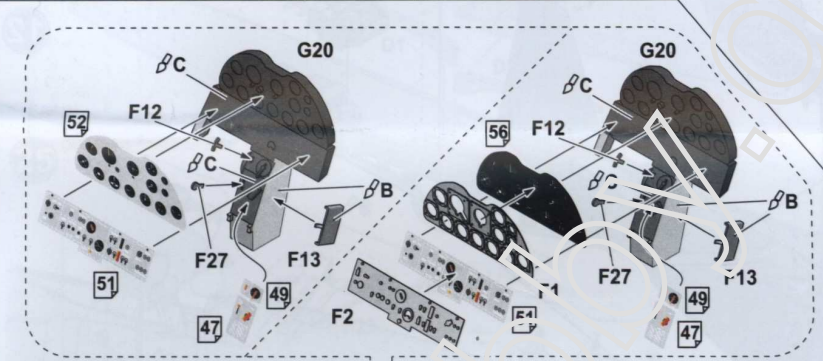
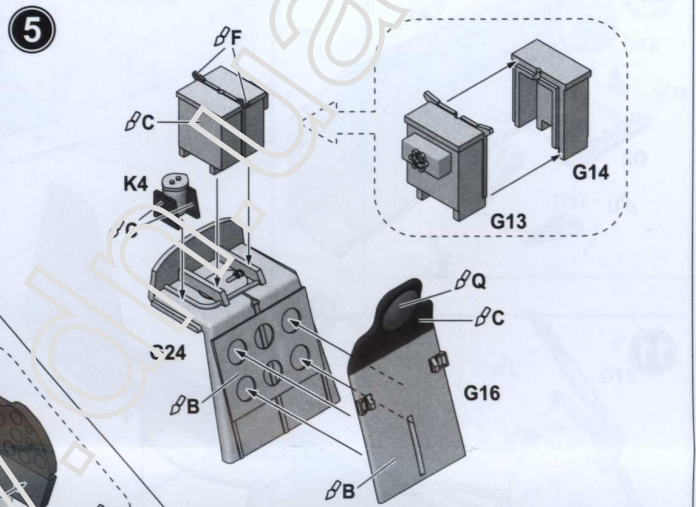
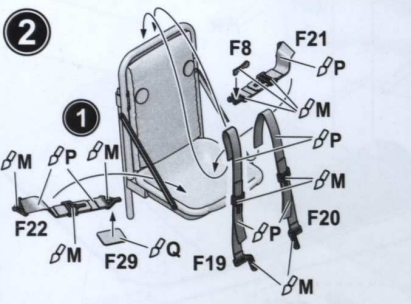
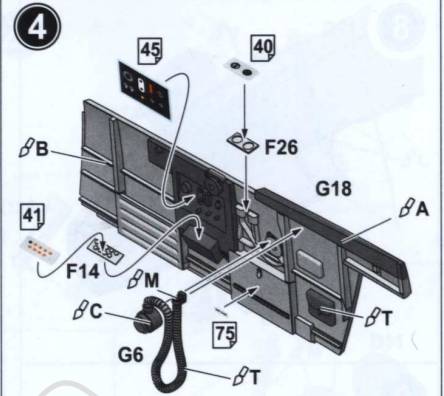
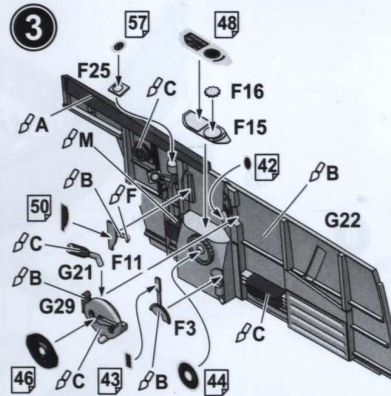
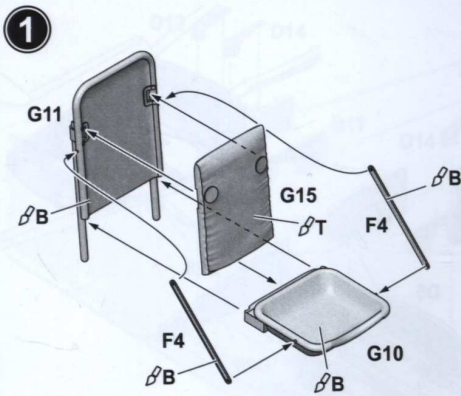
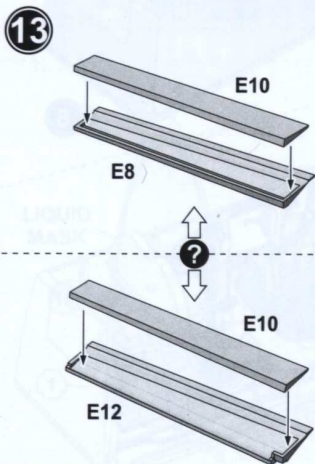
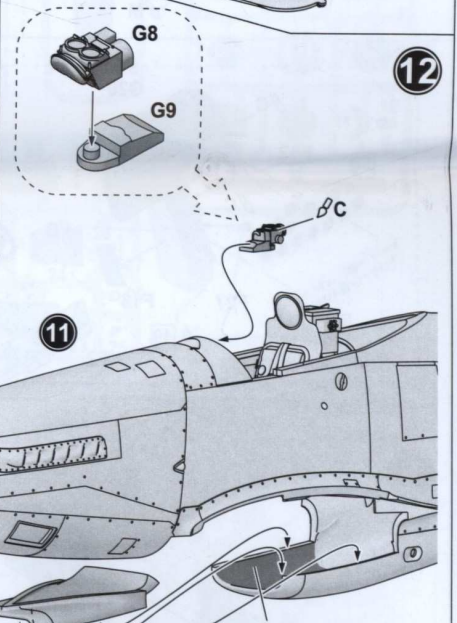
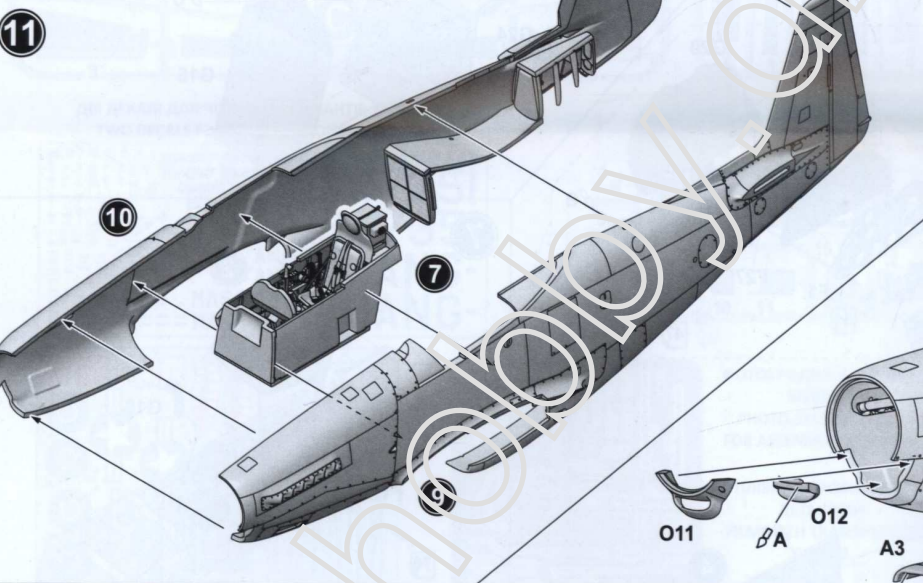
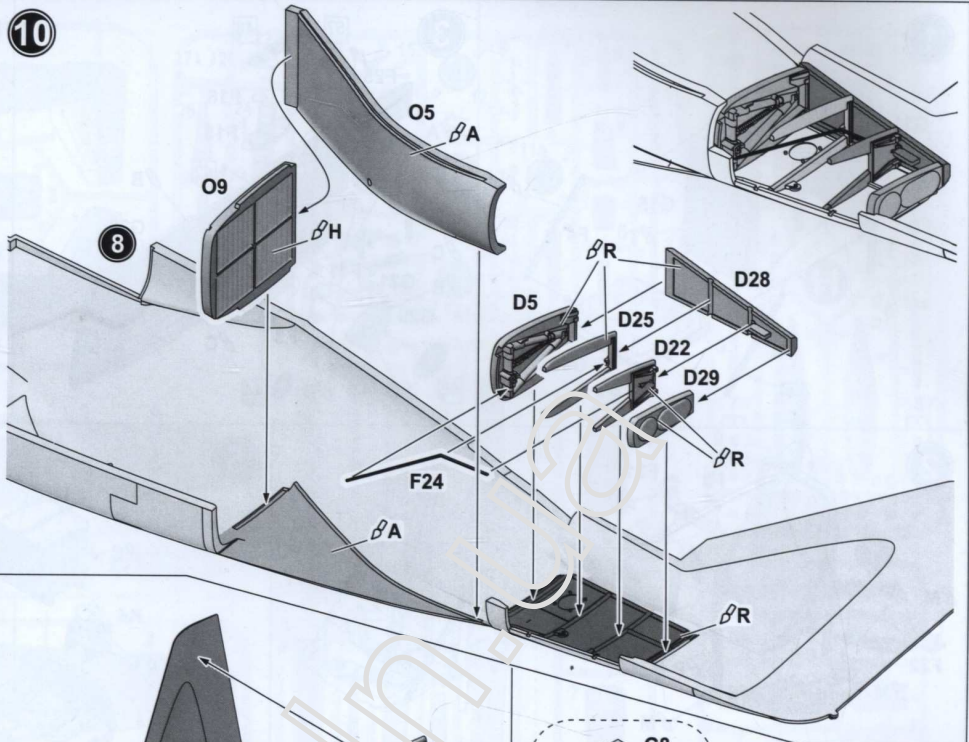
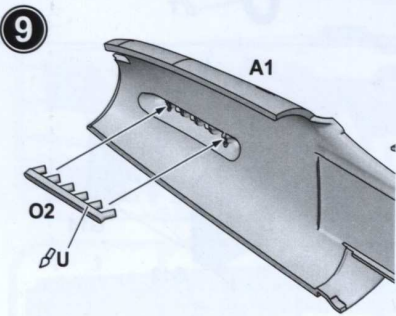
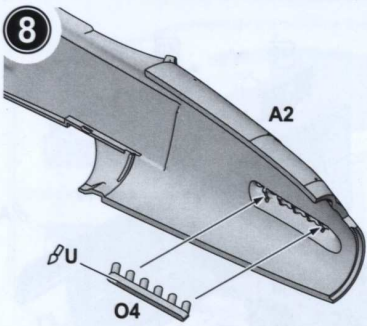
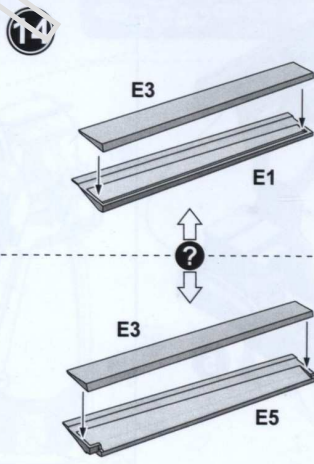

for flap down position





СХЕМА ЗБИРАННЯ / THE SCHEME OF ASSEMBLY



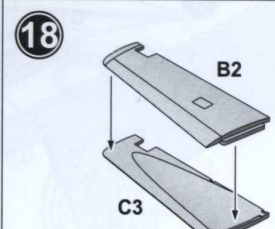
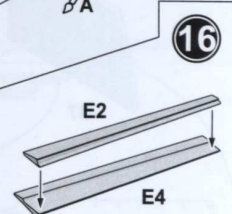
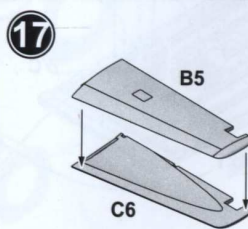
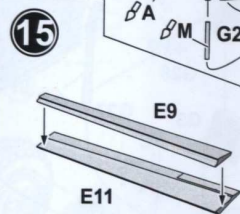

СХЕМА ЗБИРАННЯ / THE SCHEME OF ASSEMBLY



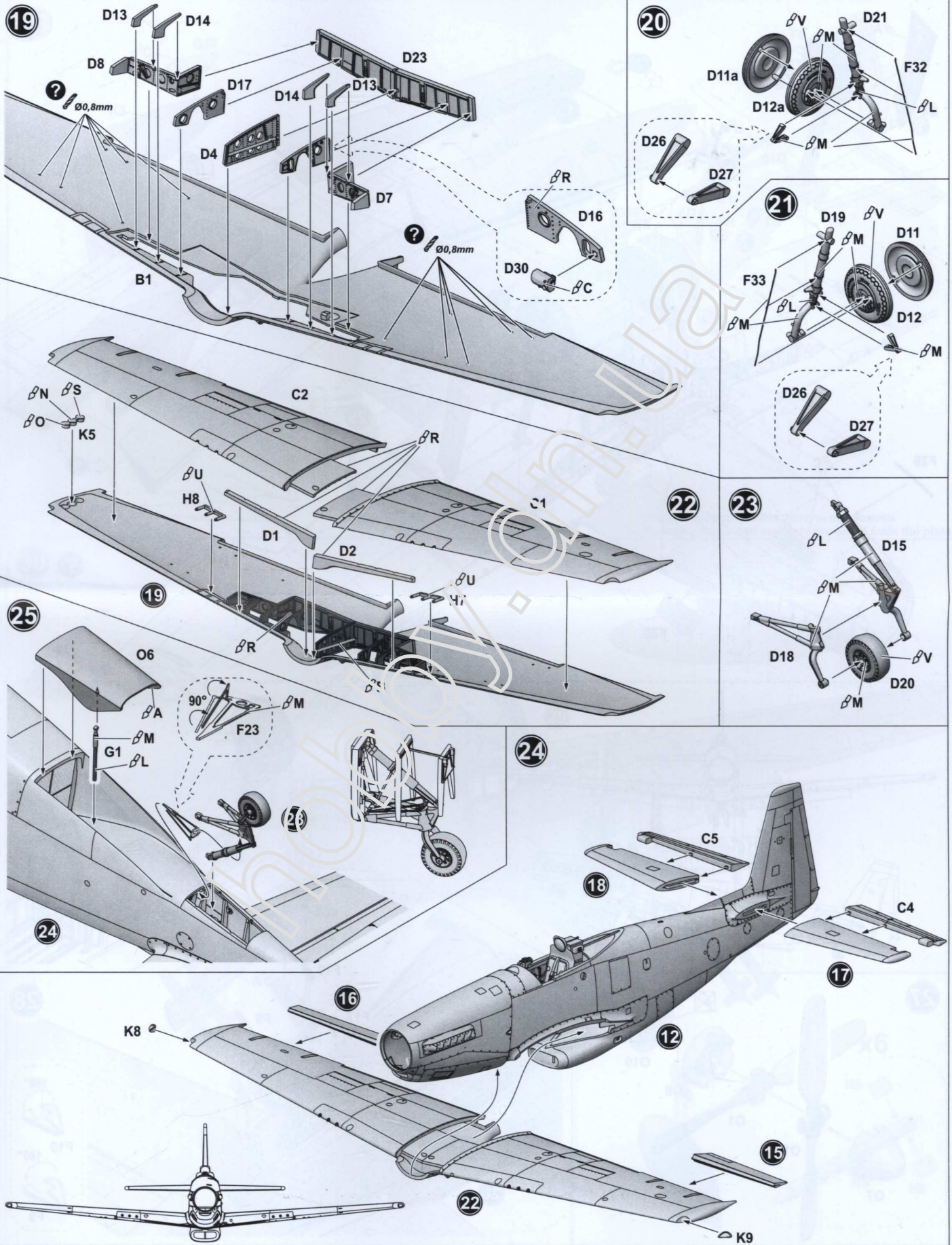

СХЕМА РОЗФАРБУВАННЯ / PAINTING SCHEME

P-51H 44-64561, 182nd FBS, Texas ANG, 1953

P-51H 44-64561, 182 винищувально-бомбардувальна ескадрилья, Національна гвардія штату Техас, 1953

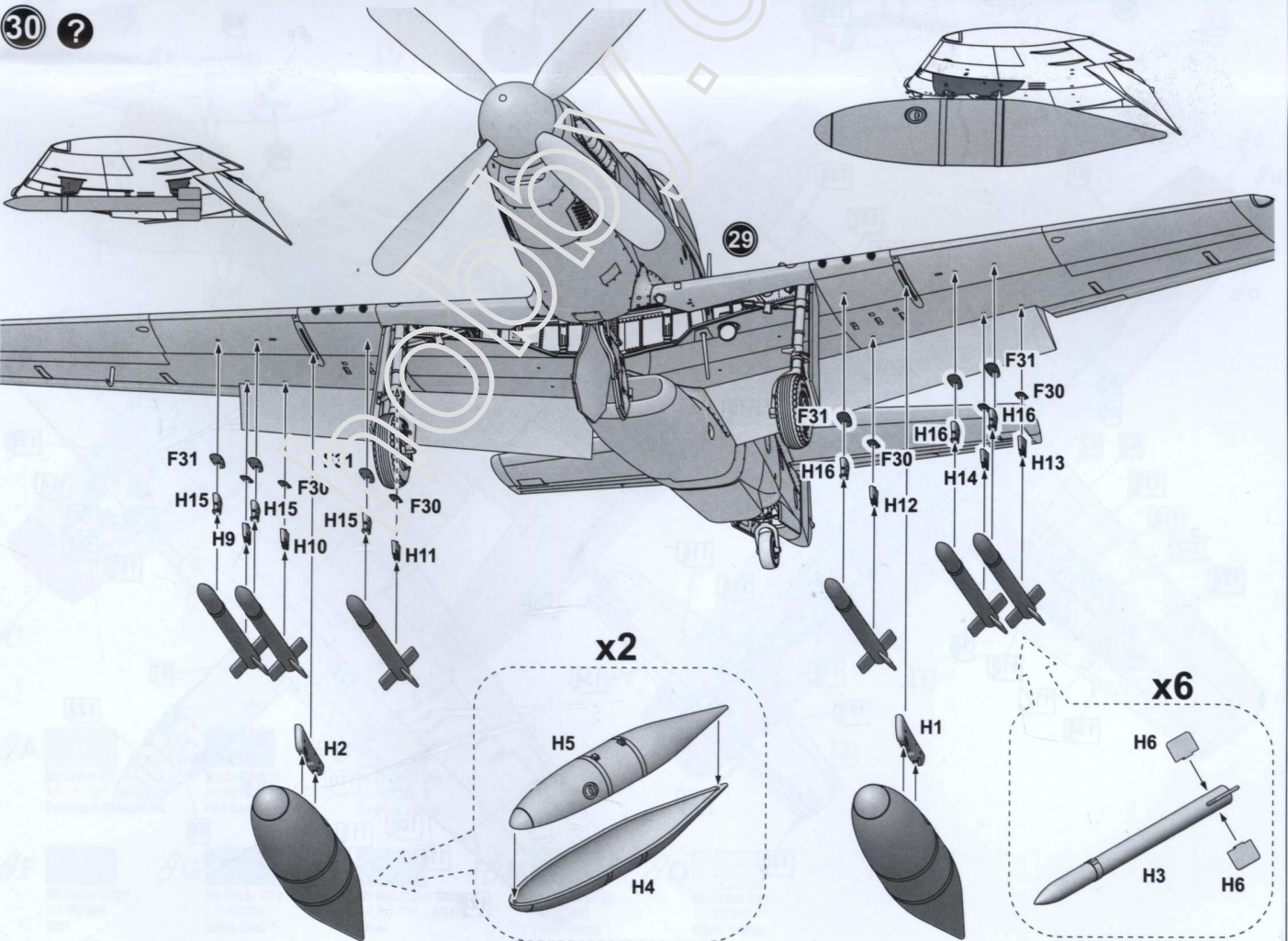
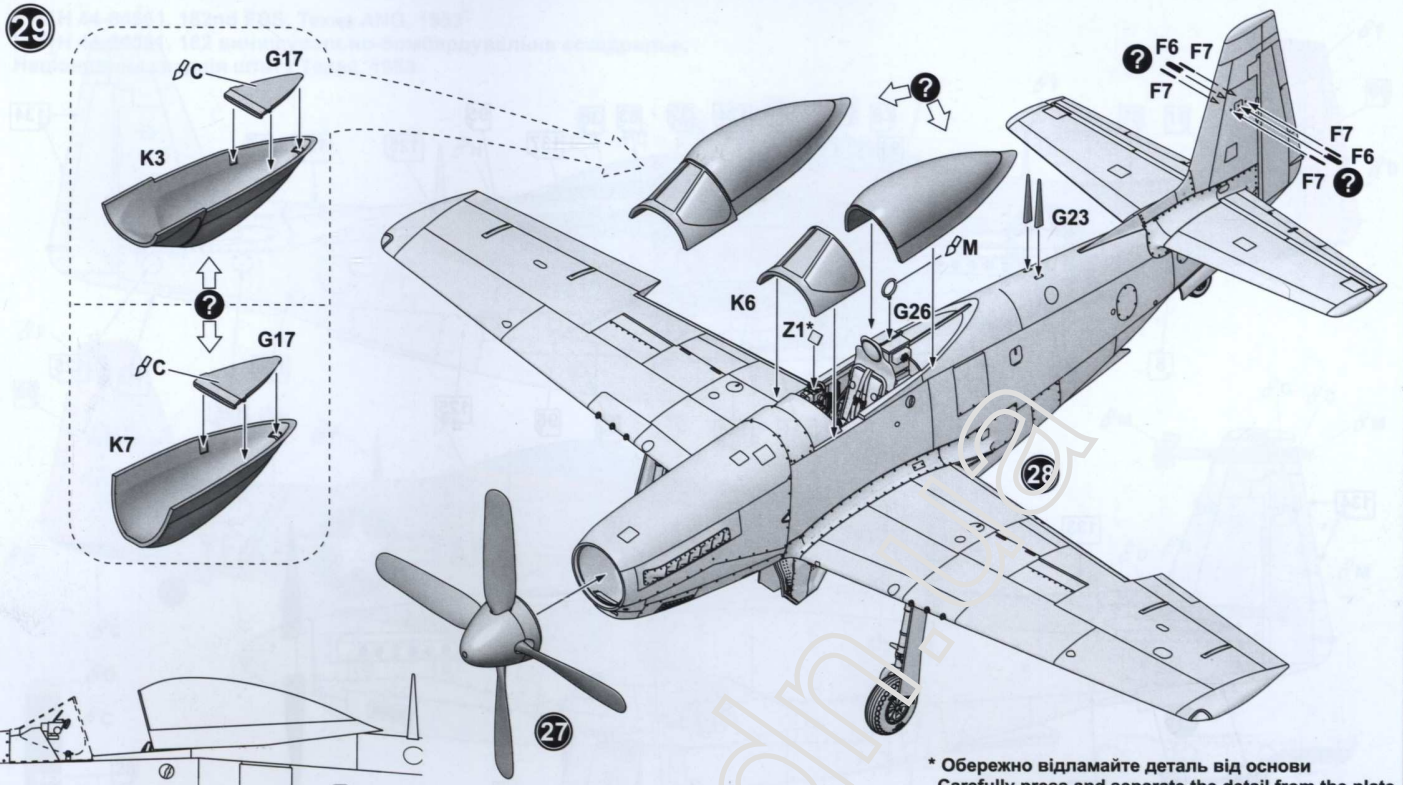

- | | | | | |
|--|---|---|---|---|
|  |  |  | | |
| Mr.Color C8
AK Xtr.Met. - AK481
Polished Aluminium | Mr.Color C33
AK RC001
Flat Black | Mr.Color C329
AK RC008
Orange Yellow | | |
|  |  |  |  |  |
| Mr.Color C327
AK RC006
Red | Mr.Color C12
AK RC259
Olive Drab | Mr.Met.Color MC213
AK Xtr.Met. - AK476
Steel | Mr.Color C138
AK RC505
Clear Green | Mr.Color C48
AK RC507
Clear Yellow |



СХЕМА РОЗФАРБУВАННЯ / PAINTING SCHEME

P-51H 44-64347, 101st FIS, Massachusetts ANG, 1951
 P-51H 44-64347, 101 винищувальна ескадрилья,
 Національна гвардія штату Массачусетс, 1951



Mr.Color C8 AK Xtr.Met. - AK481 Polished Aluminium	Mr.Color C33 AK RC001 Flat Black	Mr.Color C329 AK RC008 Orange Yellow	Mr.Color C326 AK RC258 Insignia Blue	Mr.Color C327 AK RC006 Red	Mr.Met.Color MC213 AK Xtr.Met. - AK476 Steel	Mr.Color C138 AK RC505 Clear Green	Mr.Color C48 AK RC507 Clear Yellow



СХЕМА РОЗФАРБУВАННЯ / PAINTING SCHEME

P-51H 44-64351, 133 FIS, New Hampshire ANG, 1953
P-51H 44-64351, 133 винищувальна ескадрилья,
Національна гвардія штату Нью-Гемпшир, 1953



βA Mr.Color C8
AK Xtr.Met.- AK481
Polished Aluminium

βC Mr.Color C33
AK RC001
Flat Black

βD Mr.Color C329
AK RC008
Orange Yellow

βF Mr.Color C327
AK RC006
Red

βH Mr.Met.Color MC213
AK Xtr.Met.- AK476
Steel

βN Mr.Color C138
AK RC505
Clear Green





















βO Mr.Color C48
AK RC507
Clear Yellow



СХЕМА РОЗФАРБУВАННЯ / PAINTING SCHEME

P-51H KN987, RAF, 1945
P-51H KN987, ВПС Великобританії, 1945



- | | | | | | | |
|--|--|--|--|--|---|--|
|  A  |  D  |  F  | | | | |
| Mr.Color C33
AK RC001
Flat Black | Mr.Color C329
AK RC008
Orange Yellow | Mr.Color C327
AK RC006
Red | | | | |
|  G  |  H  |  I  |  J  |  K  |  N  |  O  |
| Mr.Color C12
AK RC259
Olive Drab | Mr.Met.Color MC213
AK Xtr.Met.- AK476
Steel | Mr.Color C331
AK RC296
Sea Grey | Mr.Color C325
AK RC220
Light Grey | Mr.Color C368
AK RC290
RAF Sky | Mr.Color C138
AK RC505
Clear Green | Mr.Color C48
AK RC507
Clear Yellow |