



Mirage III V-01

CAT.NO.72023



ÉCHELLE
SCALE

1/72

ENVERGURE \ SPAN: 121 mm
LONGUEUR \ LENGTH: 250 mm
PARTIES \ PARTS: 214 pièces \ pieces































MAQUETTE A ASSEMBLER \ ÉDITION LIMITÉE
PLASTIC MODEL KITS \ LIMITED EDITION

FR En 1961, la société Marcel Dassault débute l'étude et la construction du Mirage III V-01 dont la particularité est le décollage et l'atterrissage vertical. En reprenant la formule du Dassault Balzac 01, il est équipé de huit réacteurs Royce RB 162-1 en position verticale et d'un Pratt/Snecma TF-106 comme propulsion principale. Le premier décollage vertical (captif) a lieu le 12 Février 1965, puis la première transition vol stationnaire/vol horizontal a lieu le 24 Mars 1966. Les essais se poursuivront 1 an jusqu'à l'abandon du projet. Le prototype du Mirage III V-01 est conservé au Musée de l'air et de l'espace du Bourget.











EN In 1961 Marcel Dassault began the design and development of the Mirage III V 01 vertical take-off and landing fighter aircraft.

The new Mirage had the general layout of the Dassault Balzac 01 prototype aircraft. It was fitted with eight Rolls-Royce RB 162-01 engines mounted vertically and a single Pratt/SNECMA TF-106 turbofan. The aircraft made its first vertical take-off on February 12, 1965 and the first transition from stationary to horizontal flight was made on March 24, 1966. Flying tests were conducted 1 year after they were stopped and the project was completely abandoned. The Mirage III V 01 prototype aircraft is in the Air and Space Museum in Le Bourget.

PEINTURES UTILISÉES \ REQUIRED COLOURS

 A  HUMBROL 33 NOIR BLACK	 B  HUMBROL 147 GRIS CLAIR LIGHT GREY	 C  HUMBROL 34 BLANC WHITE	 D  HUMBROL 156 CAMOUFLAGE GRIS DARK GREY	 E  HUMBROL 11 ARGENT METALLIQUE SILVER	 F  HUMBROL 56 ALUMINIUM ALUMINIUM	 G  HUMBROL 208 VERT SIGNAL BRILLANT SIGNAL GREEN	
 H  HUMBROL 153 ROUGE INSIGNE RED	 I  HUMBROL 154 JAUNE INSIGNE YELLOW	 J  HUMBROL 71 OAK SATIN OAK	 K  HUMBROL 28 CAMOUFLAGE GRIS CAMOUFLAGE GREY	 L  HUMBROL 72 KAKI MAT KHAKI DRILL	 M  HUMBROL 53 GUN METAL MÉTALLIQUE GUNMETAL	 N  HUMBROL 62 CUIR LEATHER	 O  HUMBROL 83 OCRE OCHRE

SYMBOLES \ USED SYMBOLS

 1 ÉTAPE DE MONTAGE STAGES OF ASSEMBLY	A1 NUMÉRO DE LA PIÈCE NUMBER PARTS	 1 PIÈCES SÉPARÉES SEPARATE DETAILS	 1 PLACER LA DÉCALQUE APPLY DECALS	 A PEINDRE TOUS LES DÉTAILS PAINT ALL THE DETAILS		
 COLLER GLUE	 COLLER AVEC "SUPERGLUE" GLUE ON "SUPER GLUE"	 NE PAS COLLER DON'T GLUE	 PERCER MAKE A HOLE	 COUPER AU CUTTER DETACH WITH KNIFE	 ? AU CHOIX OPTIONAL	 A À PEINDRE TO PAINT

Modèle fabriqué en "short run" et destiné aux modélistes expérimentés

The model is short run on the technology and is designed for experienced modelers



PIÈCES / COMPLETE SET

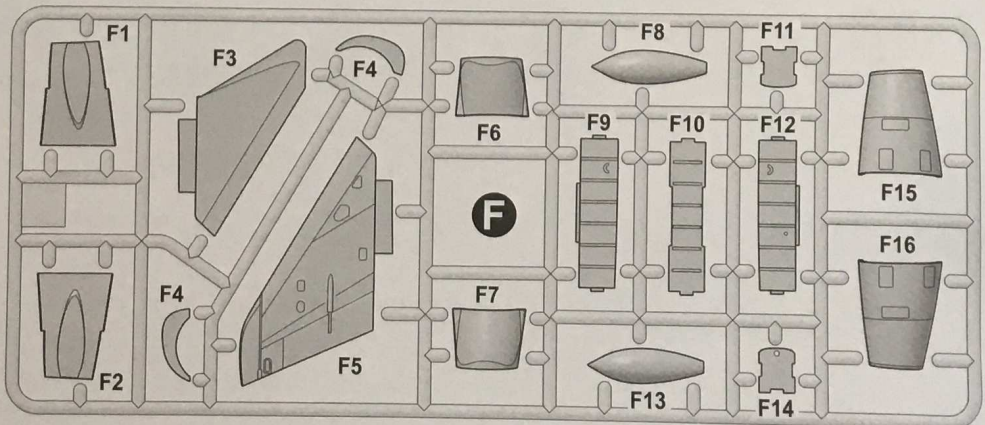
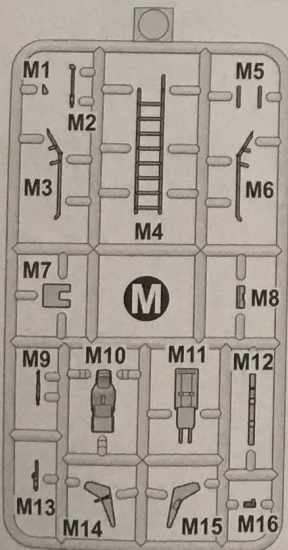
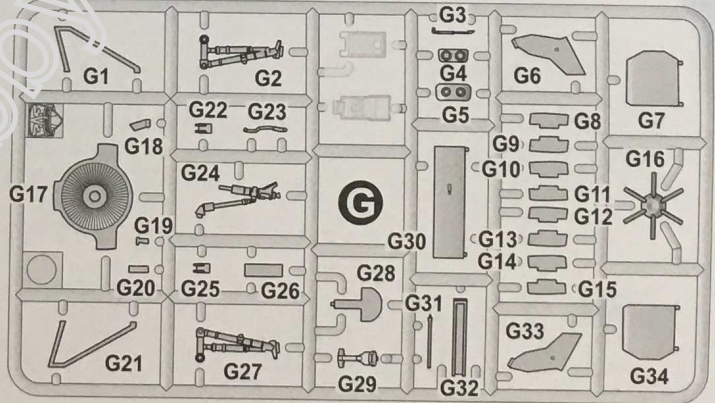
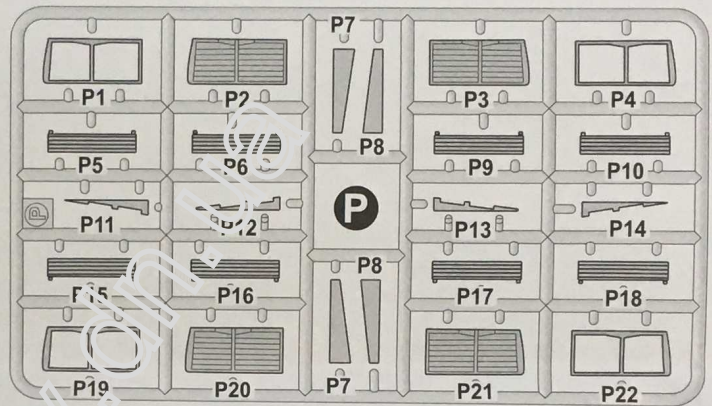
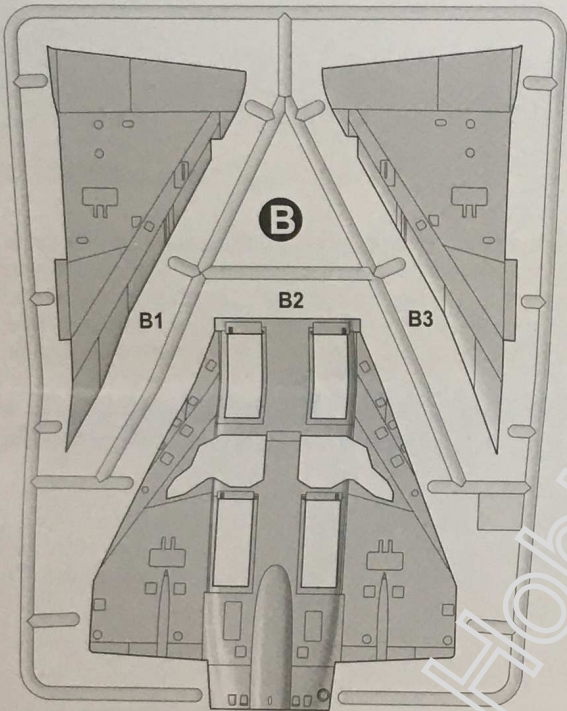
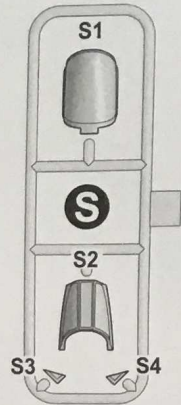
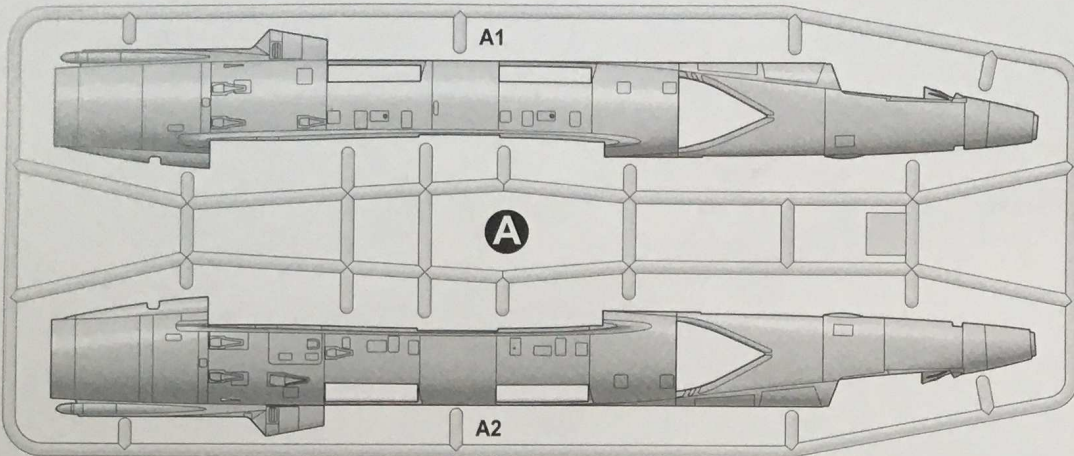



MONTAGE / THE SCHEME OF ASSEMBLY

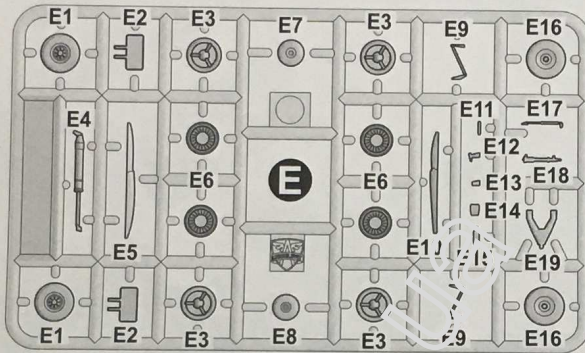
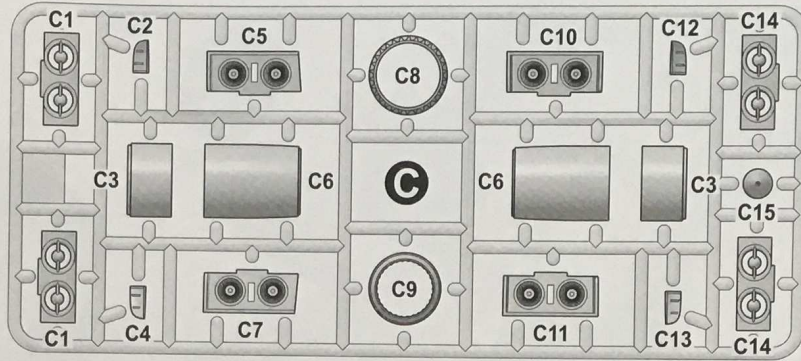
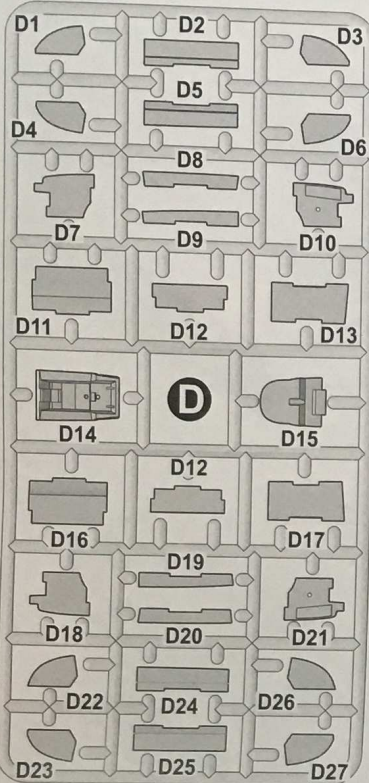

214 PIÈCES POUR LE MONTAGE
D'UNE MAQUETTE
214 DETAILS FOR ASSEMBLY
OF ONE MODEL

x2

UNE DECALQUE POUR UNE
VERSION DE CAMOUFLAGE
ONE DECAL FOR ONE VERSION
OF COLOURING

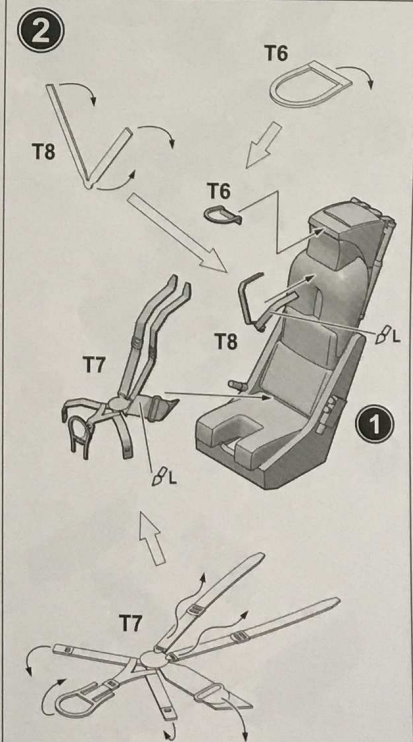
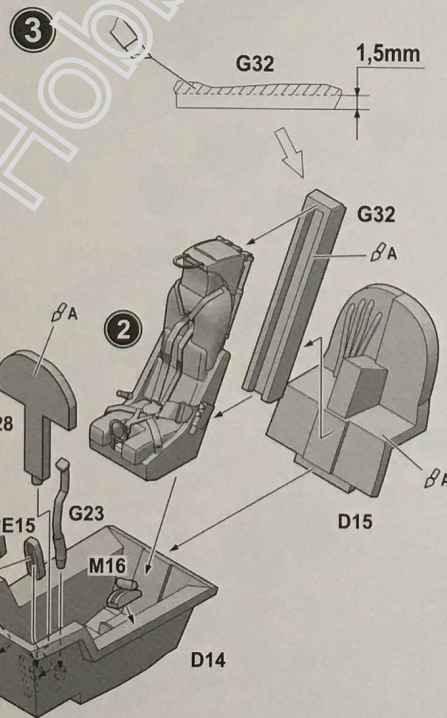
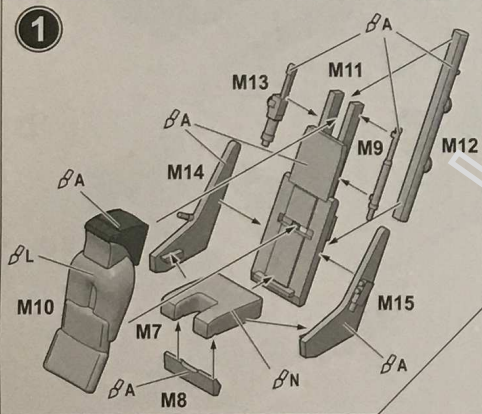
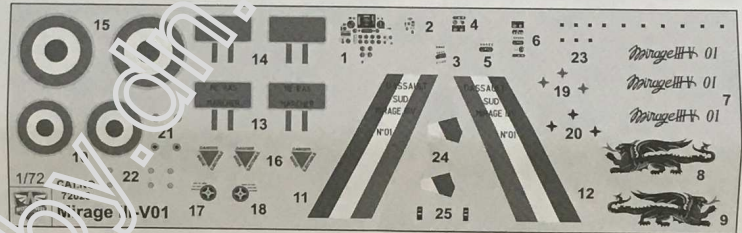
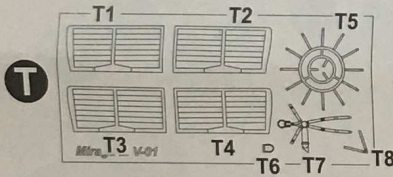



MONTAGE / THE SCHEME OF ASSEMBLY

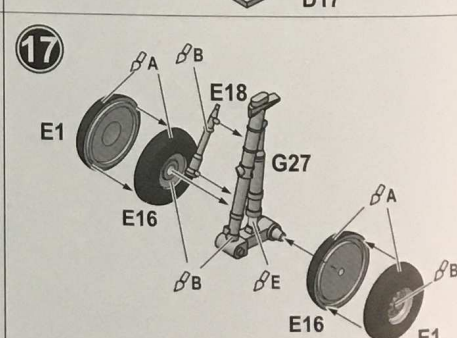
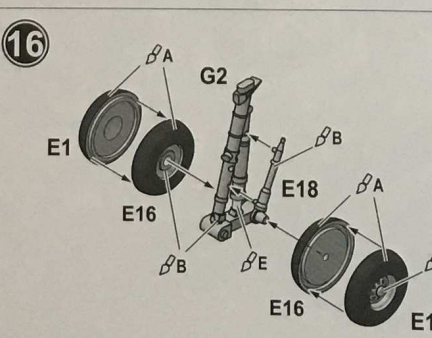
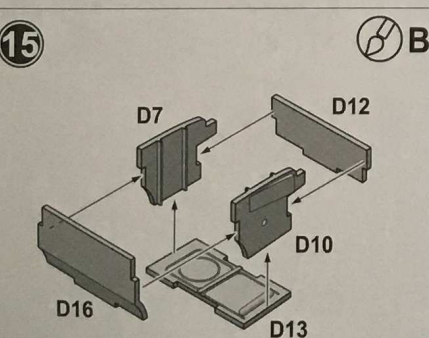
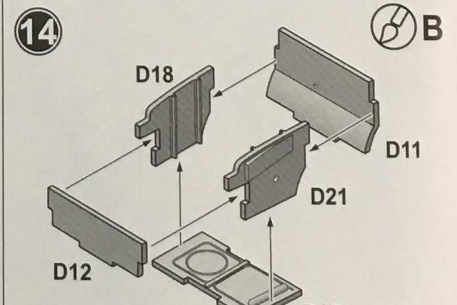
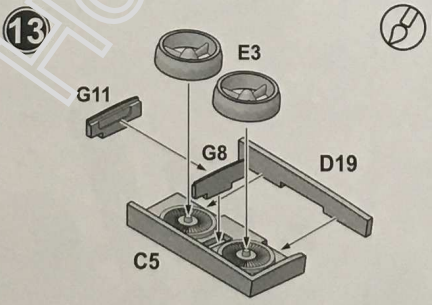
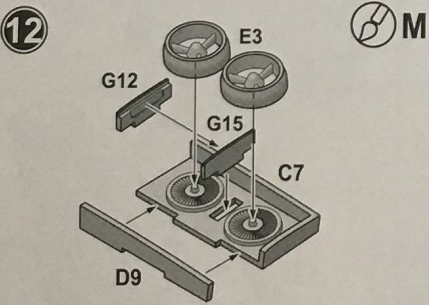
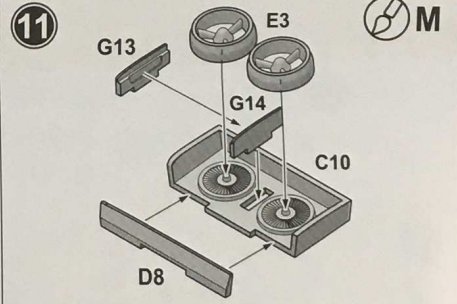
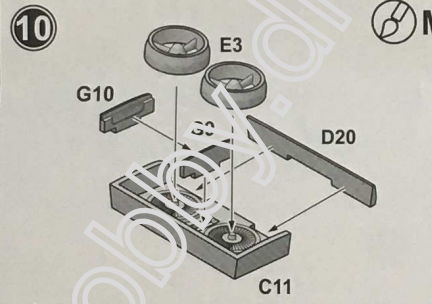
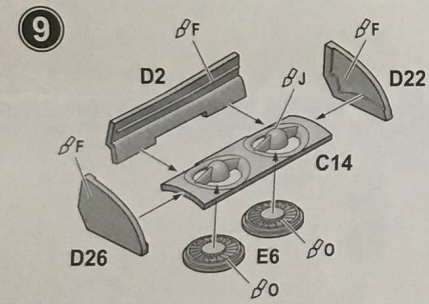
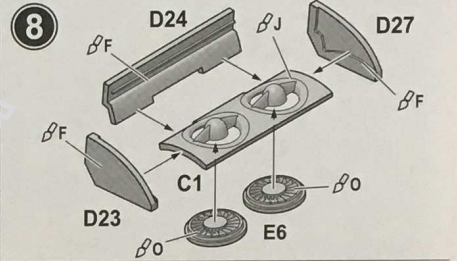
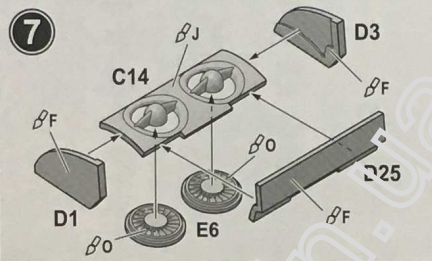
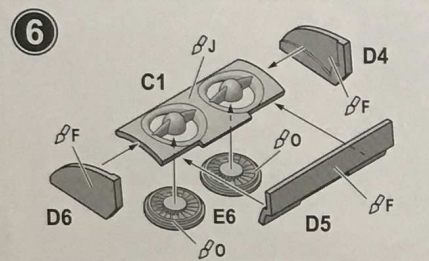
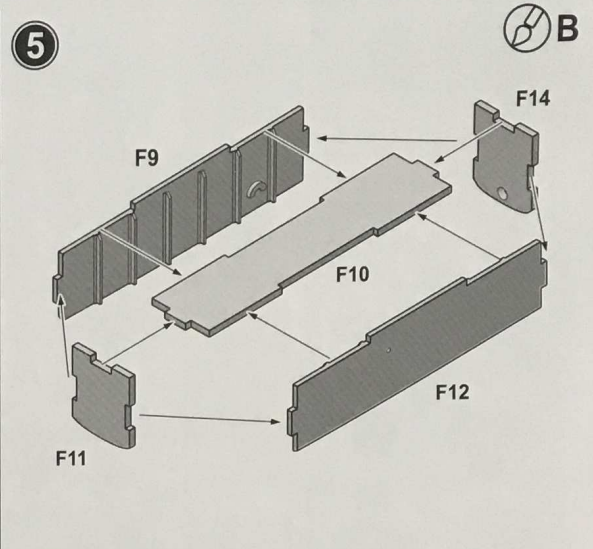
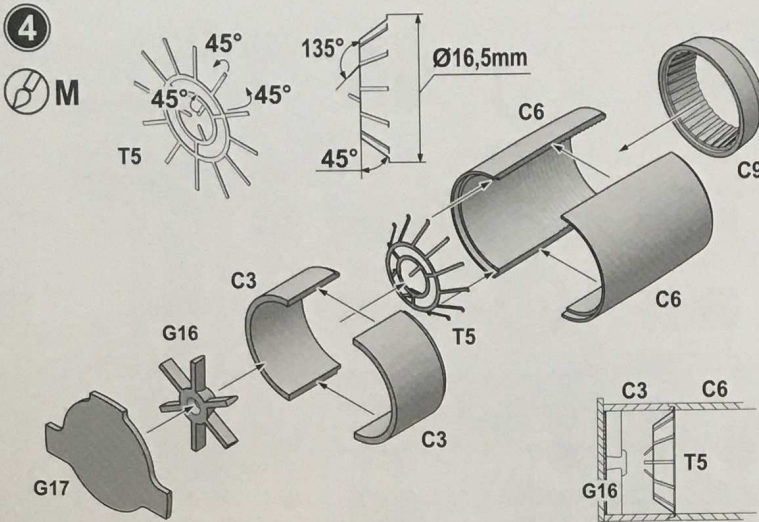



MONTAGE / THE SCHEME OF ASSEMBLY

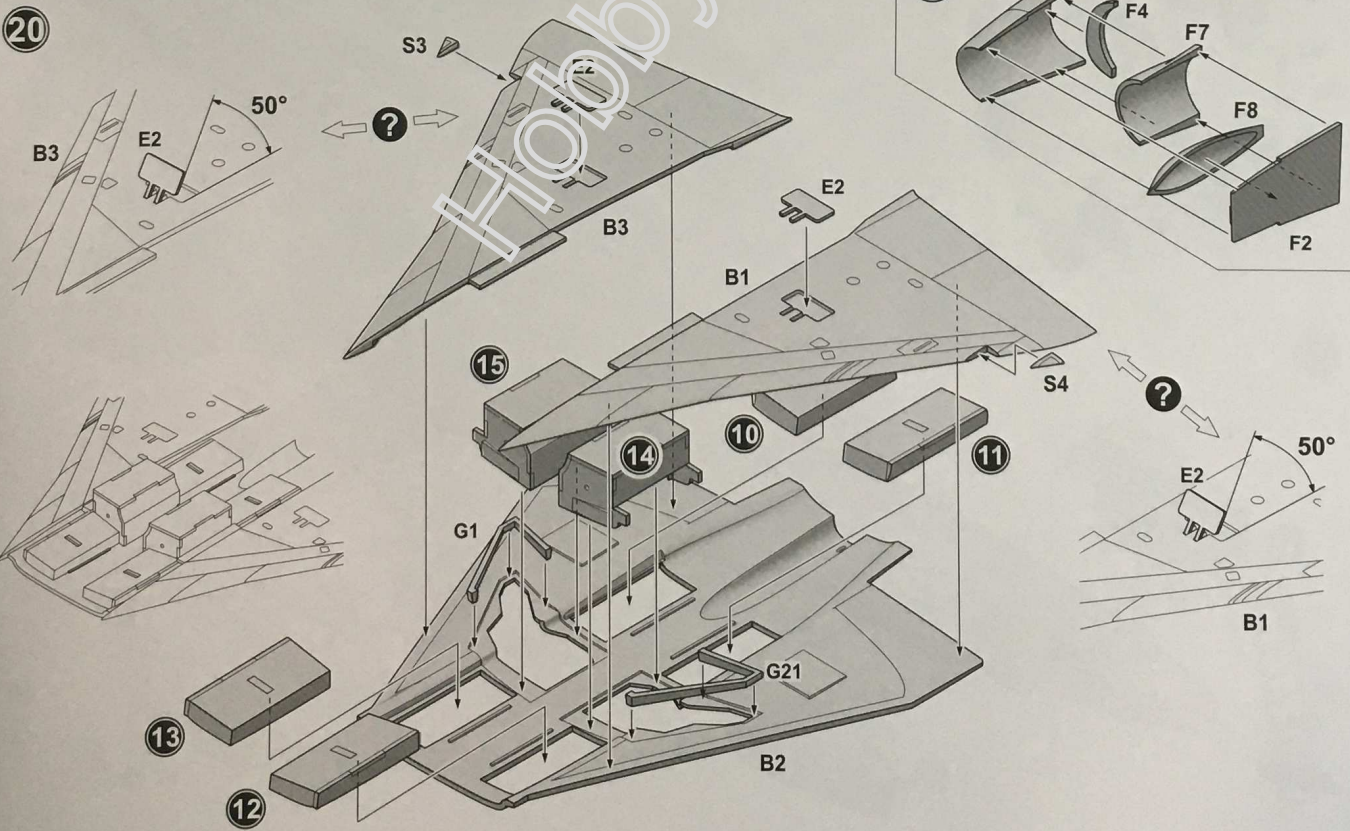
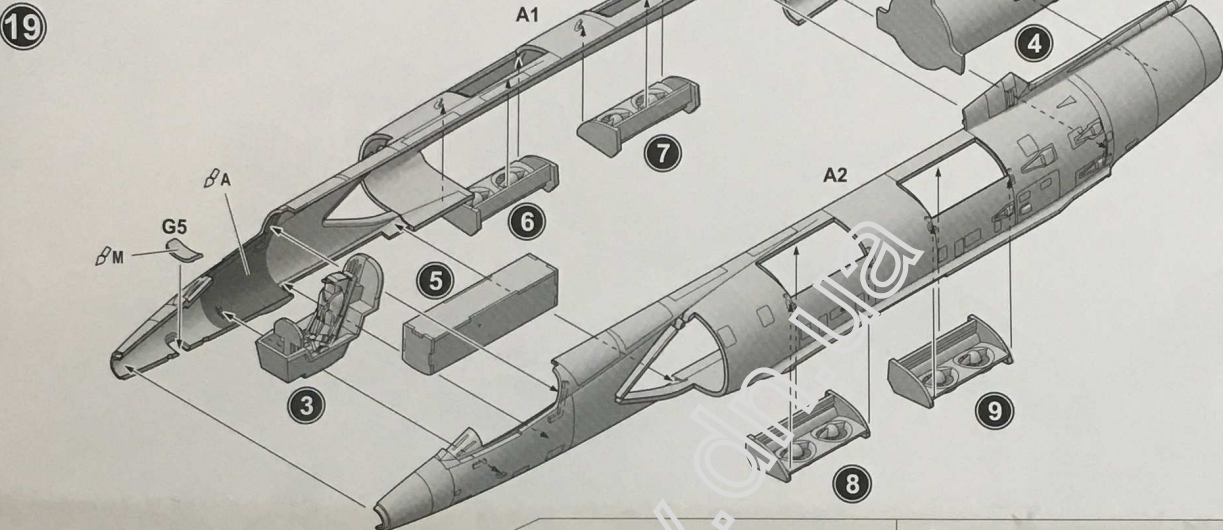
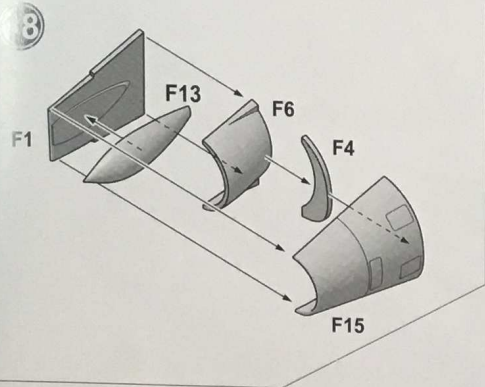



MONTAGE / THE SCHEME OF ASSEMBLY

22

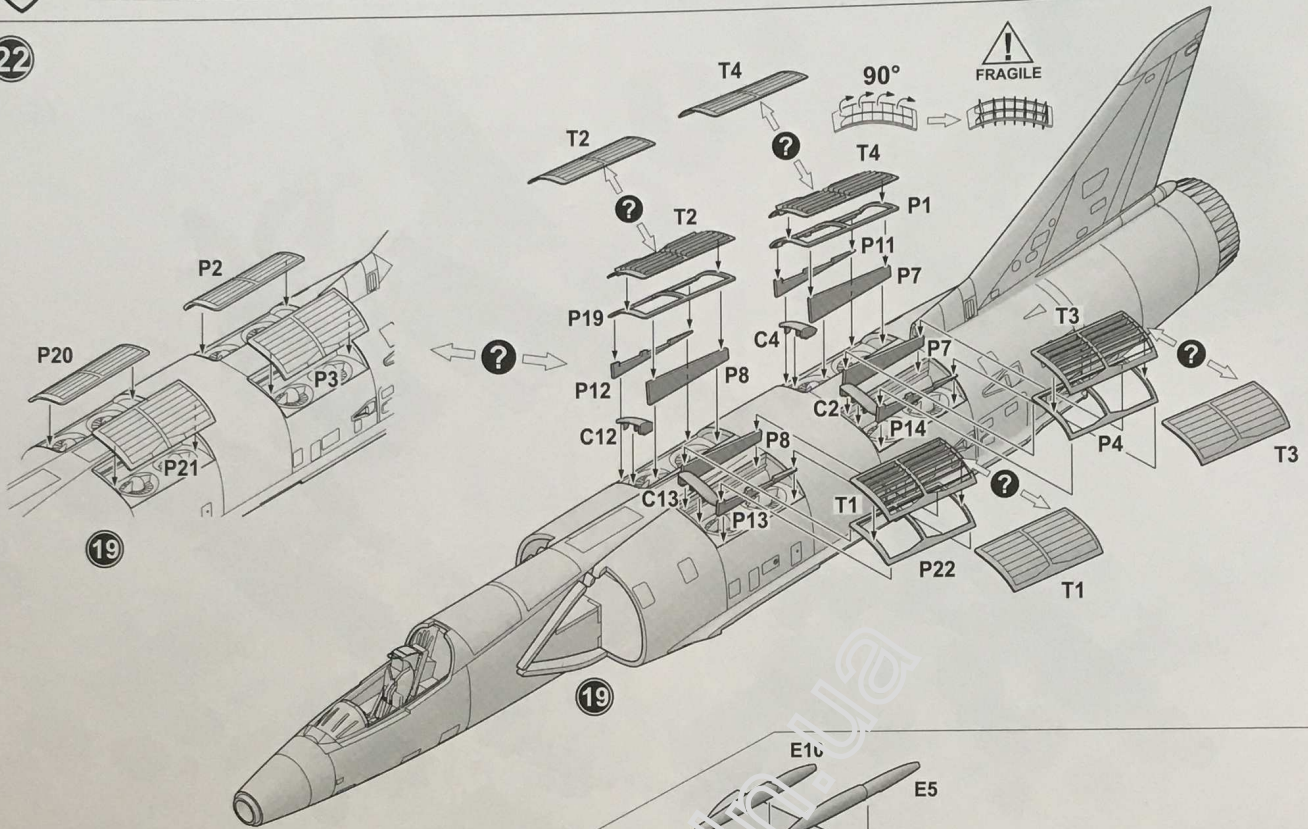

23

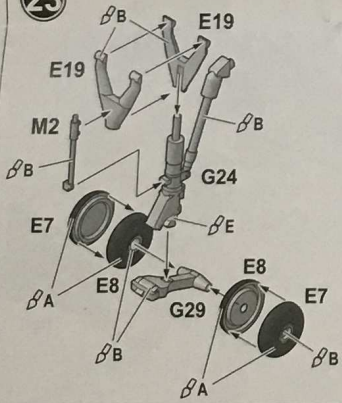

20

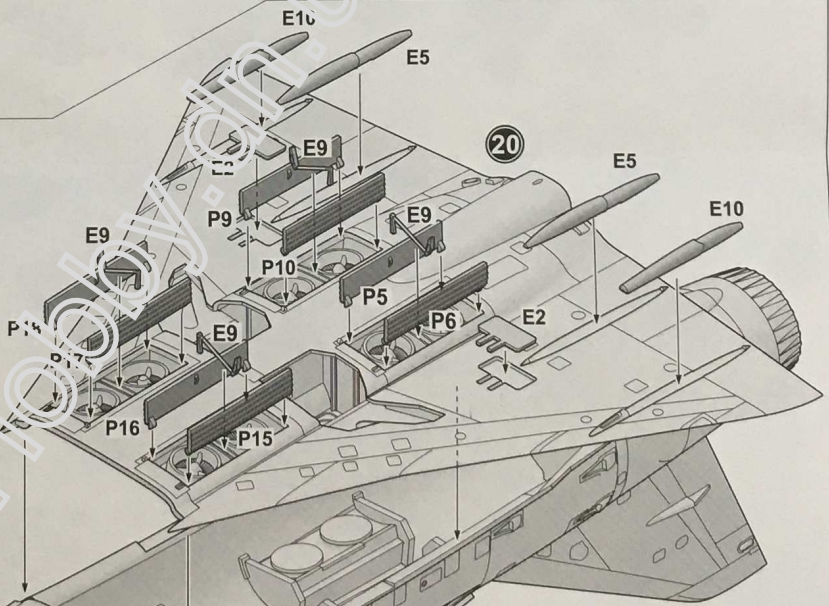

24

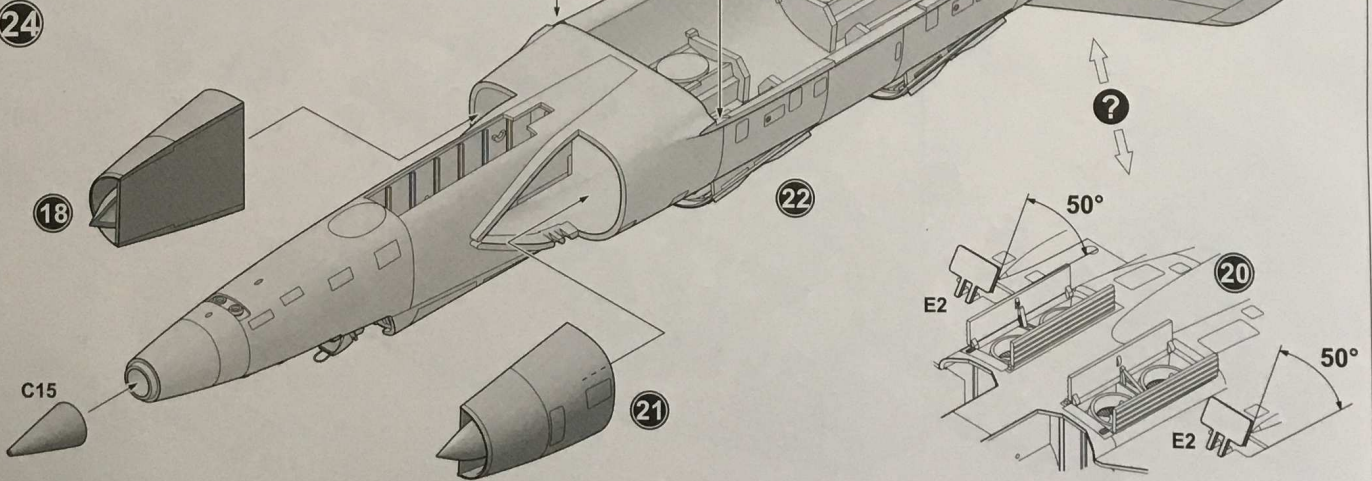



MONTAGE / THE SCHEME OF ASSEMBLY

25

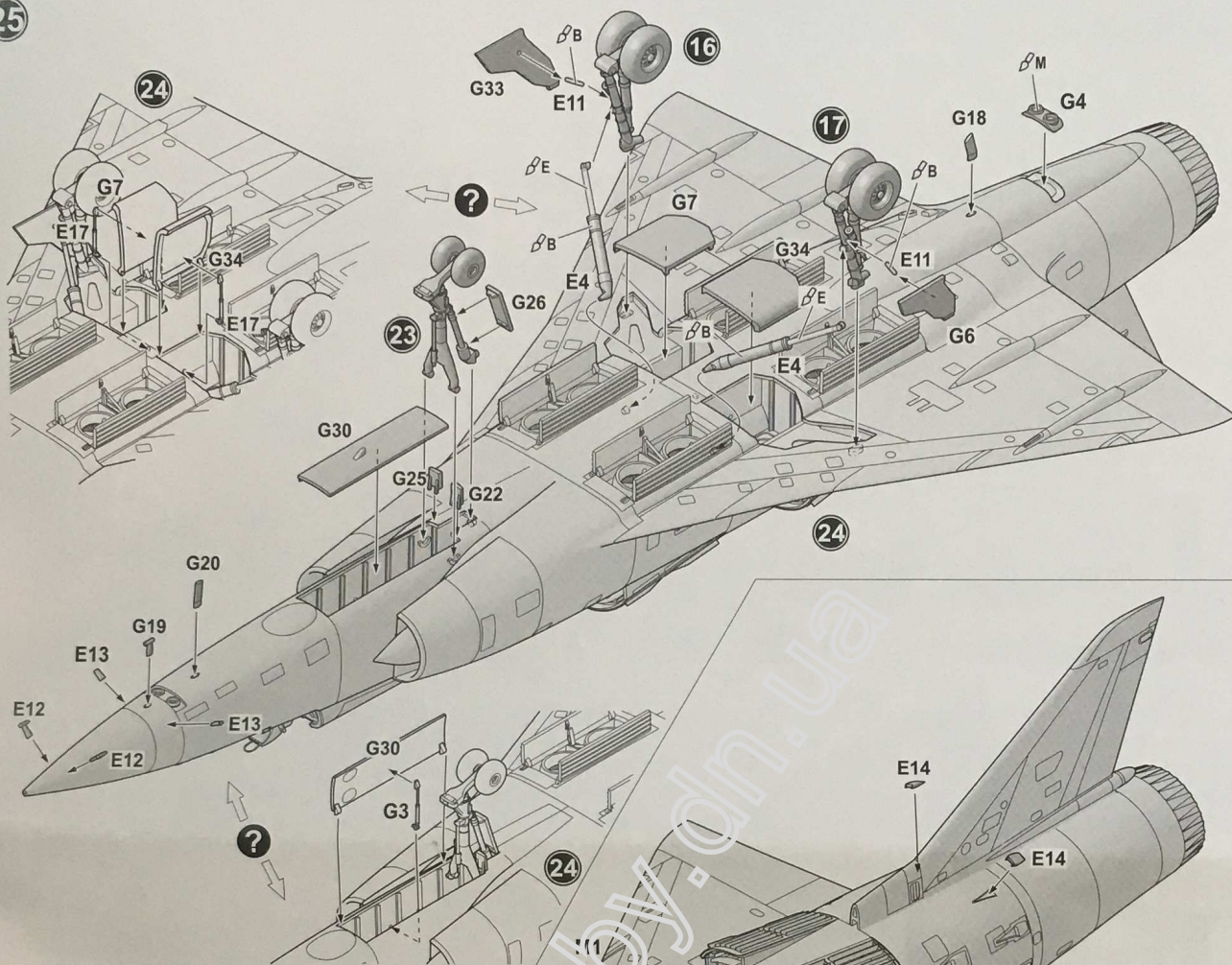

26

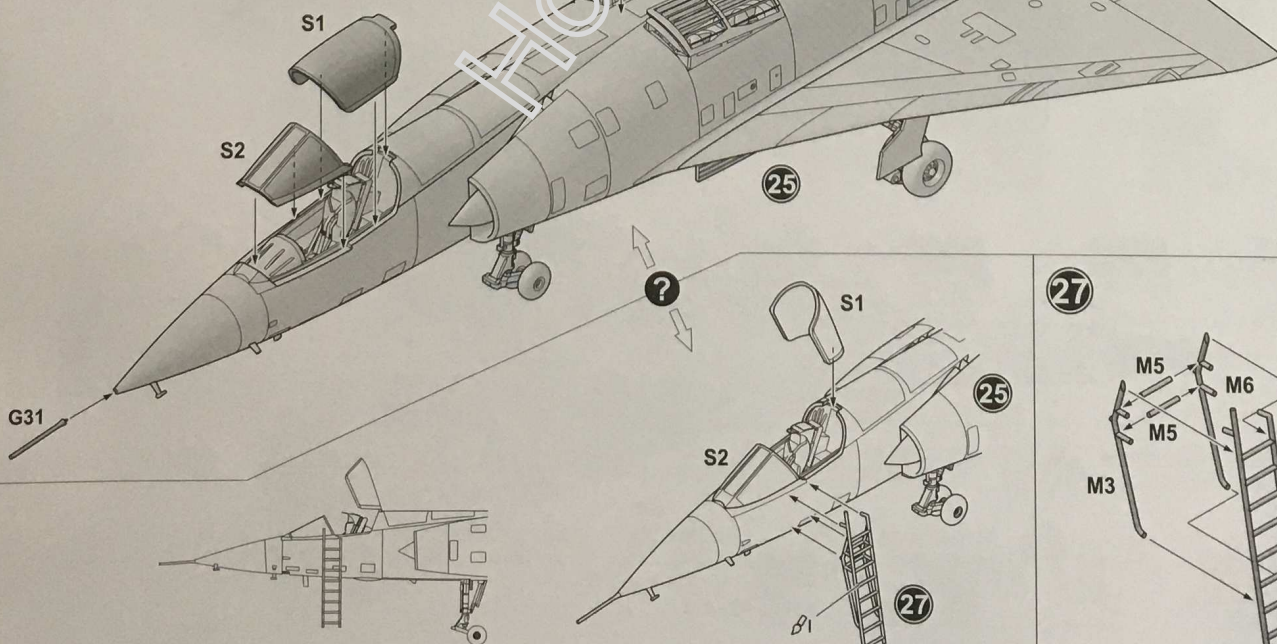

27

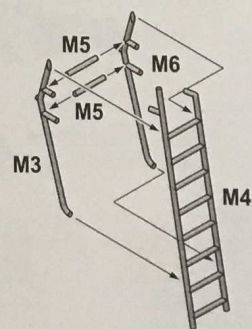



CAMOUFLAGE / THE SCHEME OF COLOURING

Dassault Mirage III-V01

