



Mirage 2000-5F

CATNO
72072



SCALE
1:72

SPAN: 127 mm
LENGTH: 199 mm
PARTS: 183 pieces

ЗБІРНА МОДЕЛЬ \ ЛІМІТОВАНИЙ ВИПУСК
PLASTIC MODEL KIT \ LIMITED EDITION

Офіційне тактико-технічне завдання на третє покоління літака з дельтаподібним крилом було видано в березні 1976 р. Літак Mirage-2000 зробили нестійким по тангажу з електродистанційною системою управління. Крило мало невелике питоме навантаження на крило та автоматичні щільні предкрилки по всьому розмаху. Mirage-2000 оснастили двигуном SNECMA M53. Прототип виконав перший політ 10 березня 1978 р. Зі результатами виробувань встановили киль зі збільшеною хордою і змінили стик крила і фюзеляжу.

Перший серійний Mirage-2000C піднявся в небо 20 листопада 1982 р. Перша партія складалася з 36 літаків.

Поставка в війська однієї серії перехоплювача Mirage-2000C почалася в квітні 1983 р. Mirage-2000C комплектувався зйомним паливоприймачем системи дозаправки в польоті. У нижній частині фюзеляжу літака під повітряозабірником встановлені дві гармати DEFA 554 (30 мм по 150 снарядів). Були дев'ять вузлів підвіски озброєння, для підвіски бомб, ракет, гондоль з розвідувальним устаткуванням, ракетні або гарматні контейнери, паливні баки сумарною масою до 6300 кг. 136 літаків Mirage-2000C експортувалися в багато країн світу. 37 літаків Mirage-2000C з F.O.L. модернізували з варіант Mirage-2000-5F для ВПС Франції.



The Mirage 2000 was a result of Dassault design work on the official tactical and technical requirements of French Air Force for 3rd generation fighter, announced in March 1976.

In the Mirage 2000 project, Dassault engineers managed to bring the delta wing up to date by moving the aircraft's center of lift to the front of its center of gravity, giving the fighter a degree of instability that enhanced maneuverability. That also reduced the take-off run.

Mirage 2000 featured a redundant "fly-by-wire" automatic flight control system (FBW AFCS), providing electronic "smarts" to compensate for the aircraft's inherent instability; two-piece elevons on each wing; and automatic, full-length, two-segment leading-edge slats. That gave the Mirage 2000 a level of agility that the Mirage III and 5 lacked, and in fact the new machine acquired a reputation for superb handling. An airbrake was fitted on top of each wing, the arrangement being very similar to that of the Mirage III. A noticeably taller tailfin allowed the pilot to retain control at higher angles of attack, assisted by small strakes mounted along each air intake.

Mirage 2000 initially was powered by single SNECMA M53-5 jet engine, rated at 88 kN (20,000 lbf) of thrust with afterburner.

The first prototype made its maiden flight on 10th of March 1976 with Jean Coreau at the controls. There were 4 single-seat prototypes, including the first Mirage 2000 prototype mentioned above. The first production Mirage 2000C flew in November 1982. Initial deliveries were in 1983. The first operational squadron was formed in 1984, just in time for the 50th anniversary of the French Air Force.

French Air force received in total 124 Mirage 2000C, 37 of which have been upgraded to the Mirage-2000-5F variant.

НЕОБХІДНІ ФАРБИ \ REQUIRED PAINTS

A Intermediate Blue Mr.Color C366 AK RC235	B Light Ghost Grey Mr.Color C338 AK RC252	C Dark Grey Mr.Color C332 AK RC244	D Grey Mr.Color C31 AK RC251	E Light Grey Mr.Color C338 AK RC253	F Dark Gull Grey Mr.Color C317 AK RC247	G Aluminium Mr.Met.Color MC218 AK Xtr.Met.- AK479	H Gun Metal Mr.Met.Color MC214 AK Xtr.Met.- AK483	I Flat Black Mr.Color C33 AK RC001
J Pale Yellow Mr.Color C313 AK RC018	K White Mr.Color C62 AK RC004	L Red Mr.Color C47 AK RC503	M Khaki Mr.Color C55 AK RC096	N Green Mr.Color C303 AK 2303	O Yellow Mr.Color C4 AK RC007	P Blue Mr.Color C110 AK RC011	R Burnt Metal Mr.Color C61 AK Xtr.Met.- AK484	S Chrom Silver Mr.Met.Color MC211 AK Xtr.Met.- AK477
T Steel Mr.Met.Color MC213 AK Xtr.Met.- AK476	U Zinc Chromate Mr.Color C351 AK RC028	V Rubber/Tires Mr.Color C137 AK RC022	X Grey Mr.Color C306 AK RC249	Z Hull Red Mr.Color C029 AK RC067	W Midnight Blue Mr.Color C71 AK 5043			

УМОВНІ СИМВОЛИ \ USED SYMBOLS

1 ЕТАПИ ЗБИРАННЯ STAGES OF ASSEMBLY	A1 НОМЕР ДЕТАЛІ PART NUMBER	1 ОКРЕМІ ДЕТАЛІ SEPARATE DETAILS	1 НАКЛЕЇТИ ДЕКАЛИ APPLY DECALS	1 НАКЛЕЇТИ МАСКУ APPLY THE ADHESIVE MASK	? НА ВИБІР OPTIONAL
A ВАРІАНТИ ДЛЯ ЗБИРАННЯ VARIANTS OF ASSEMBLY	PS КЛЕЇТИ НА СУПЕРКЛЕЙ GLUE ON "SUPER GLUE"	X НЕ КЛЕЇТИ DON'T GLUE	1 ЗРОБИТИ ОТВІР MAKE A HOLE	1 ВІДРІЗАТИ НОЖЕМ DETACH WITH KNIFE	A ФАРБУВАТИ TO PAINT

Модель вироблена за технологією «short run»
і призначена для досвідчених моделістів

This model is produced using short run technology,
designed for experienced modelers



Комплектність / Complete set

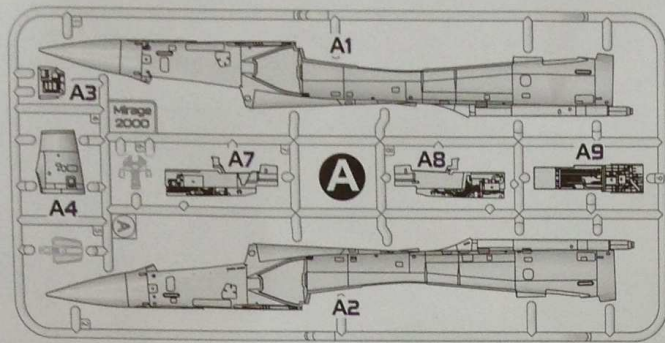

A

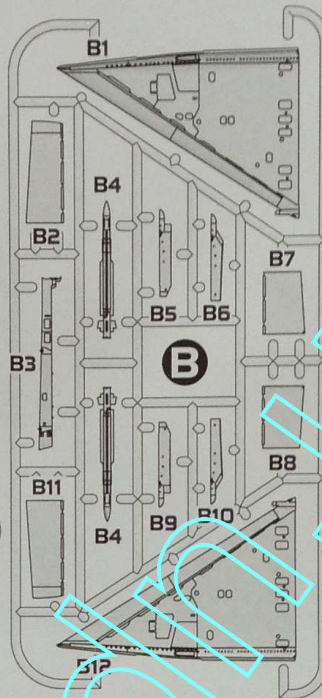

B

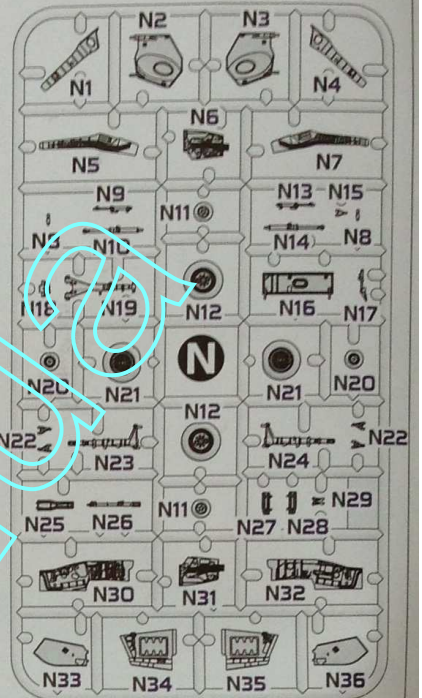

N

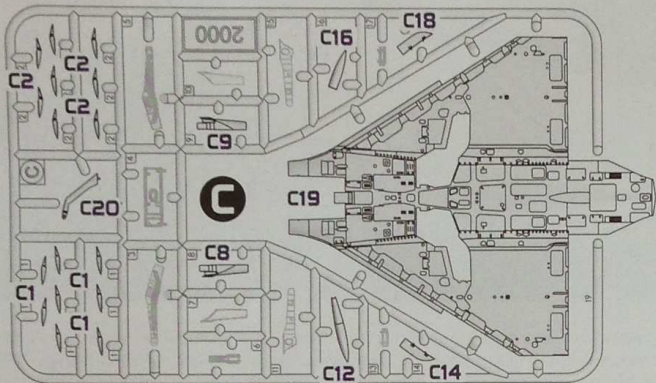

C

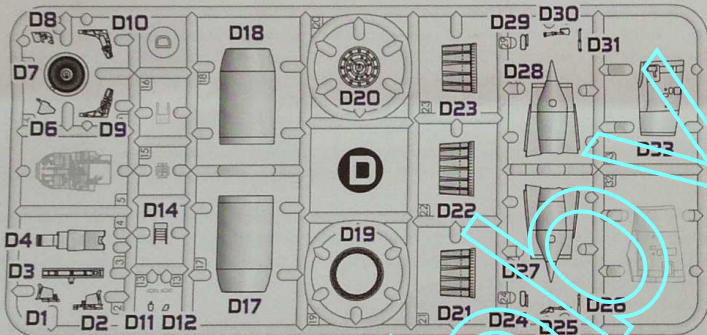

D

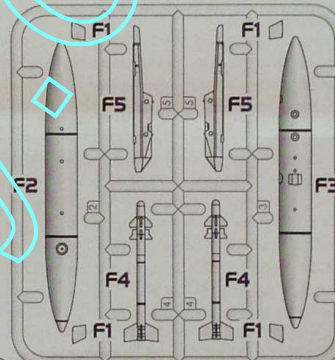

F

G

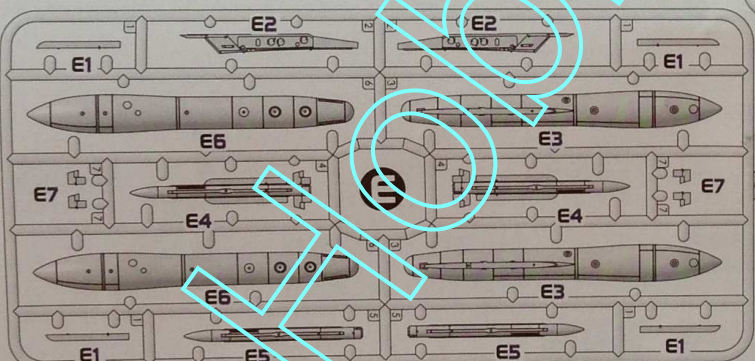

E

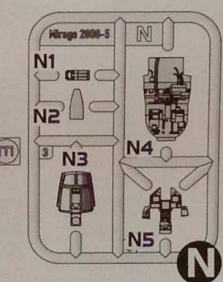

M

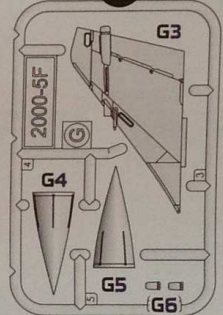

N

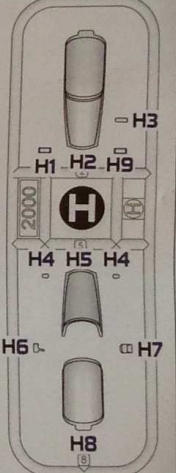

H

одна декаль для чотирьох варіантів фарбування
one decal for four versions of colouring

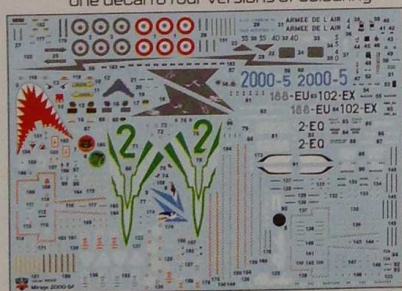

лист фотоетчу
photo-etched sheet

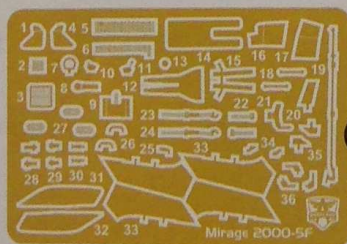

Z

плівка з прозорими
деталлями
film with transparent
details

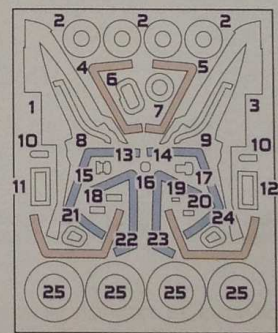

маски для фарбування
masks for painting

- зовні
outside
- всередині
inside



Схема збирання / The scheme of assembly





Схема збирання / The scheme of assembly

10

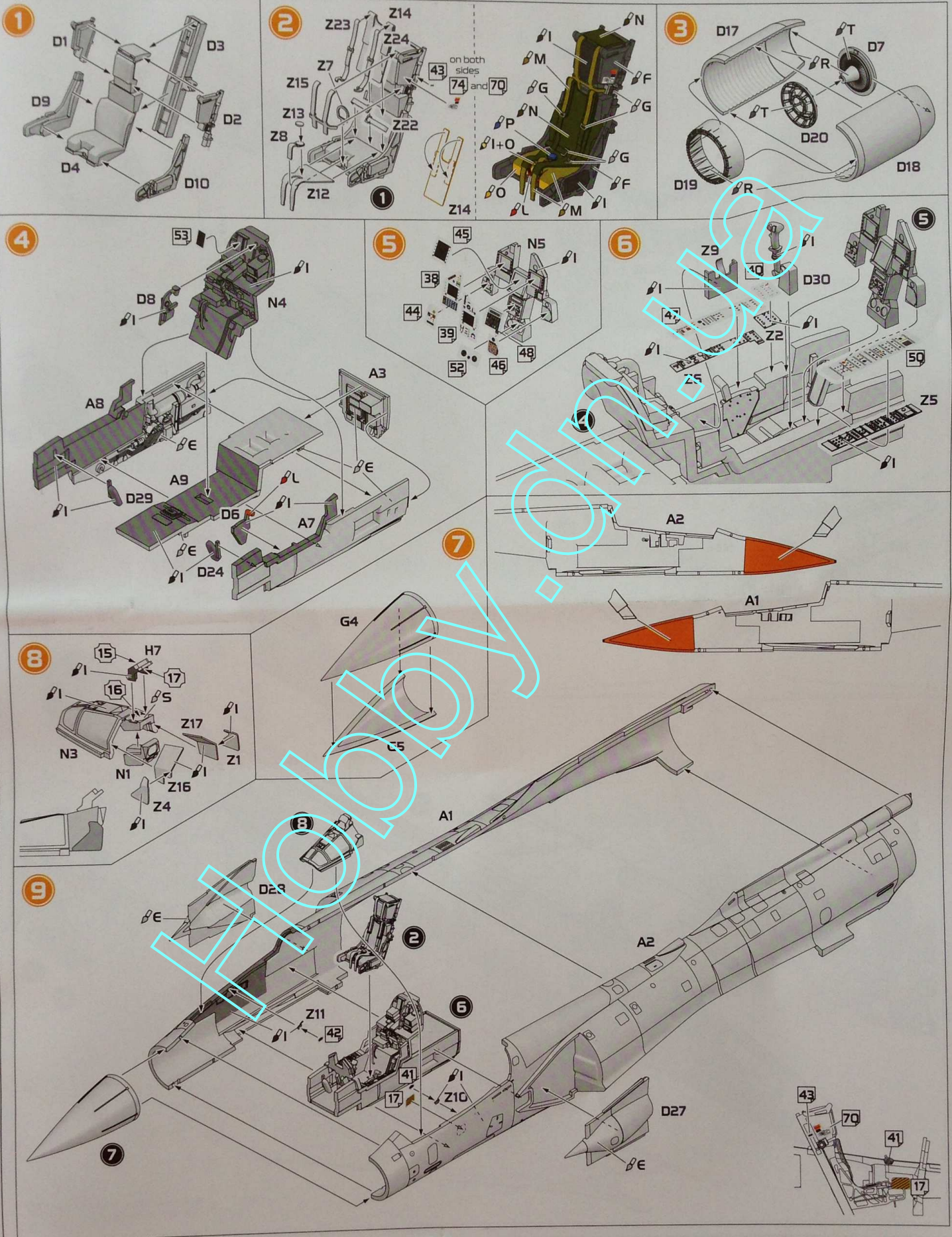
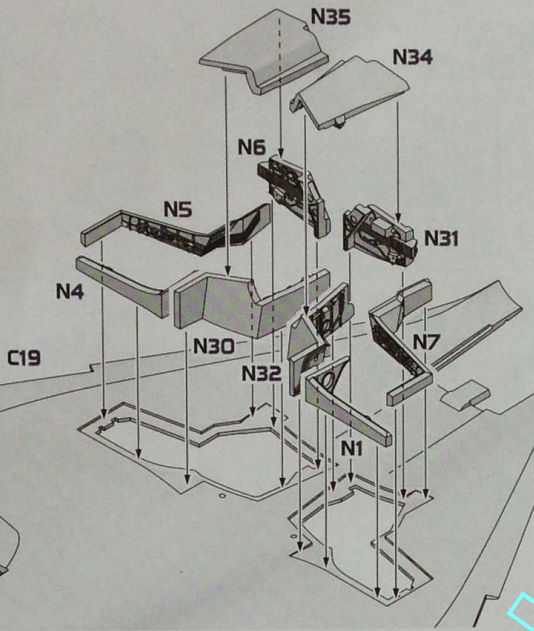

11

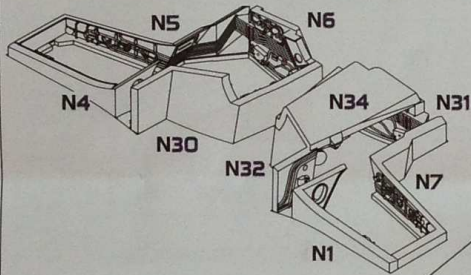
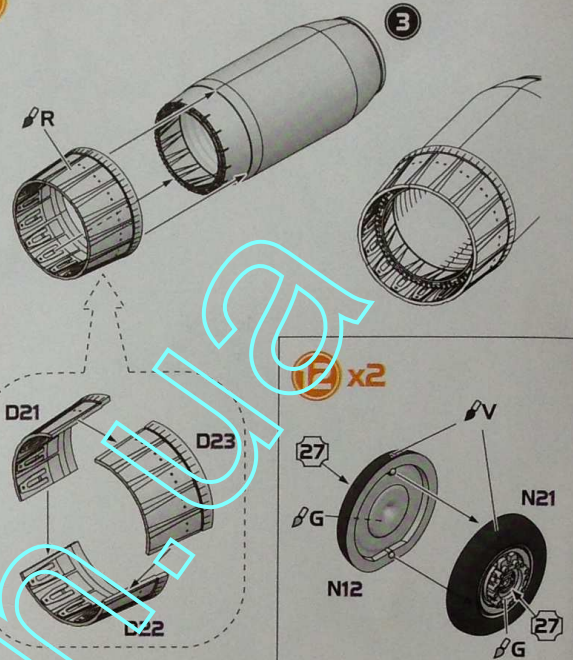

13

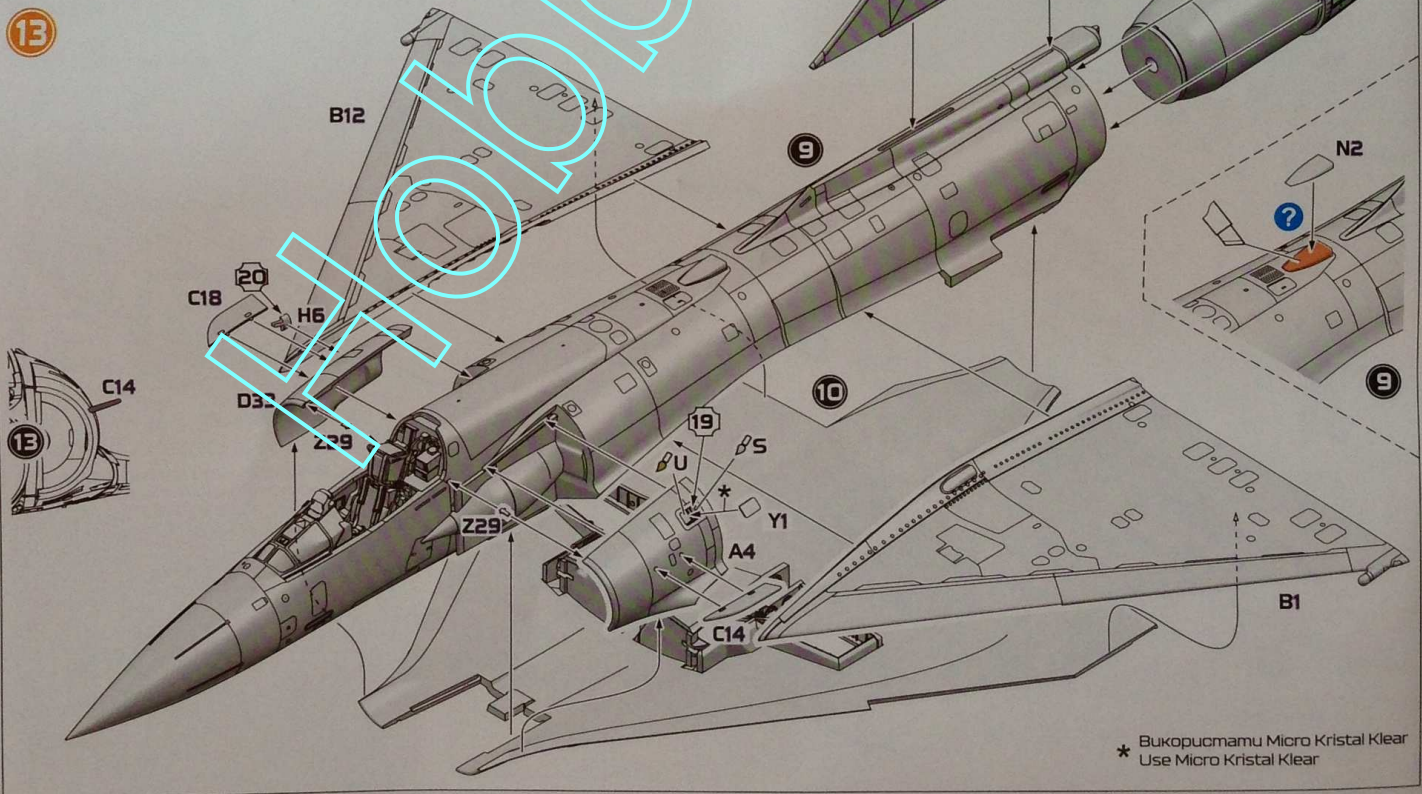

* Вискозниму Micro Kristal Klear
Use Micro Kristal Klear



Схема збирання / The scheme of assembly





Схема збирання / The scheme of assembly



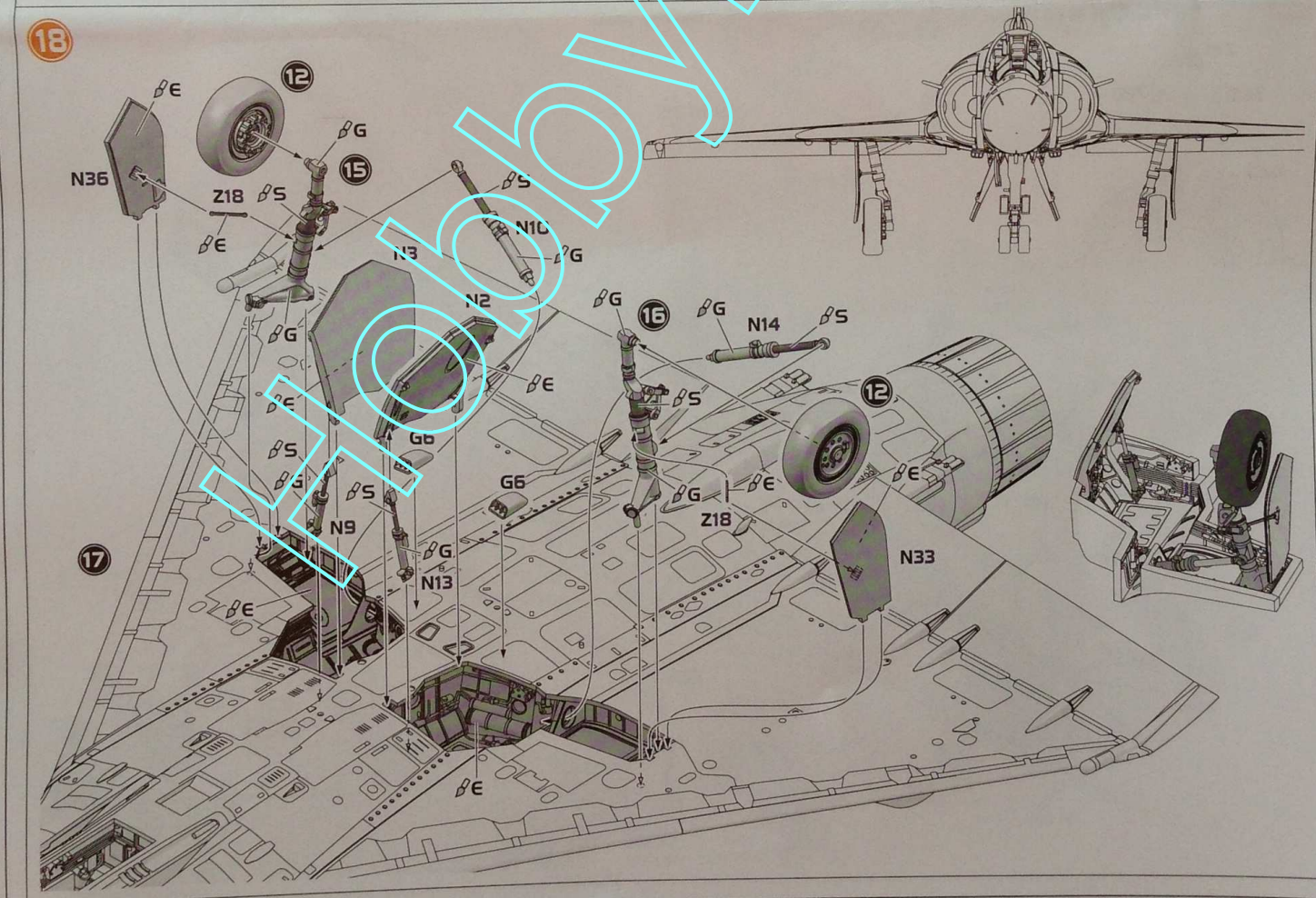
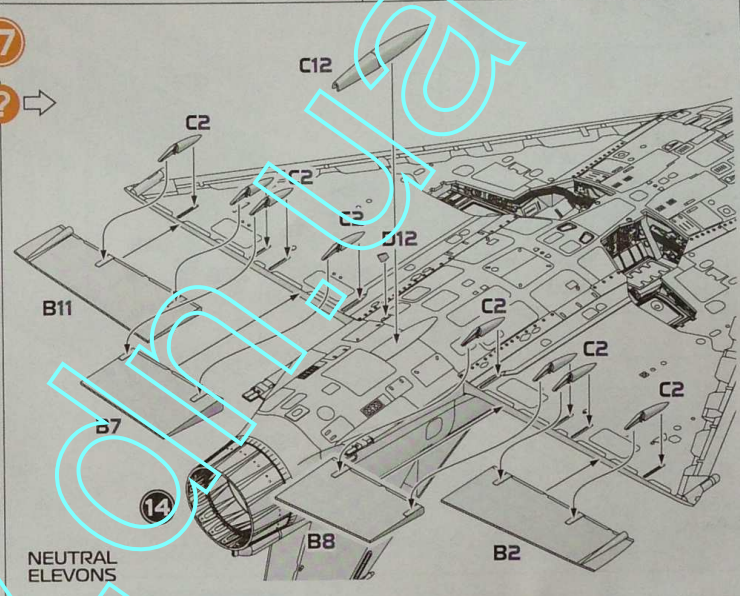
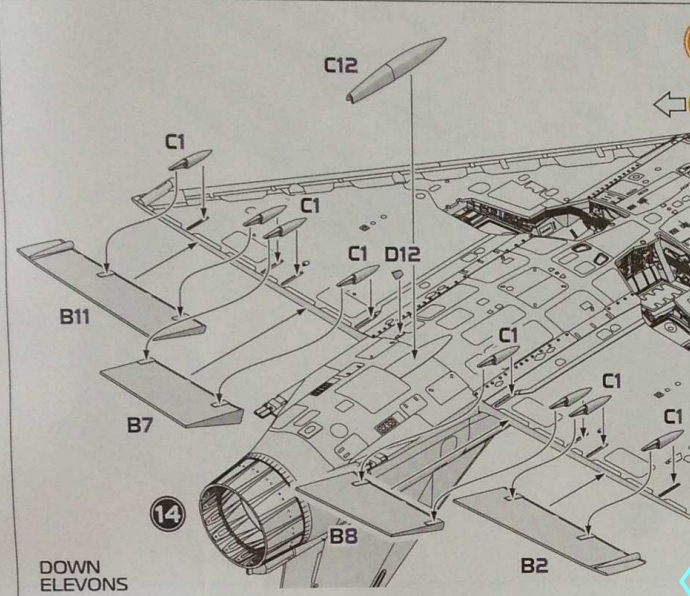
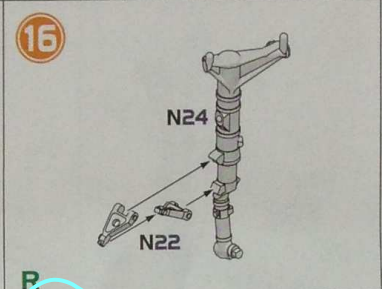
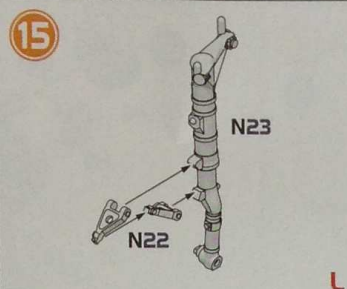
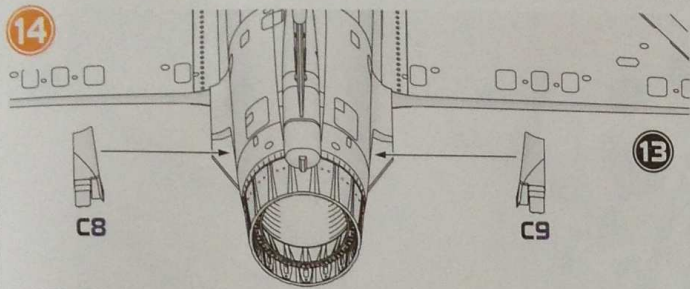

Схема збирання / The scheme of assembly



RP-522 1300L
Fuel Tank

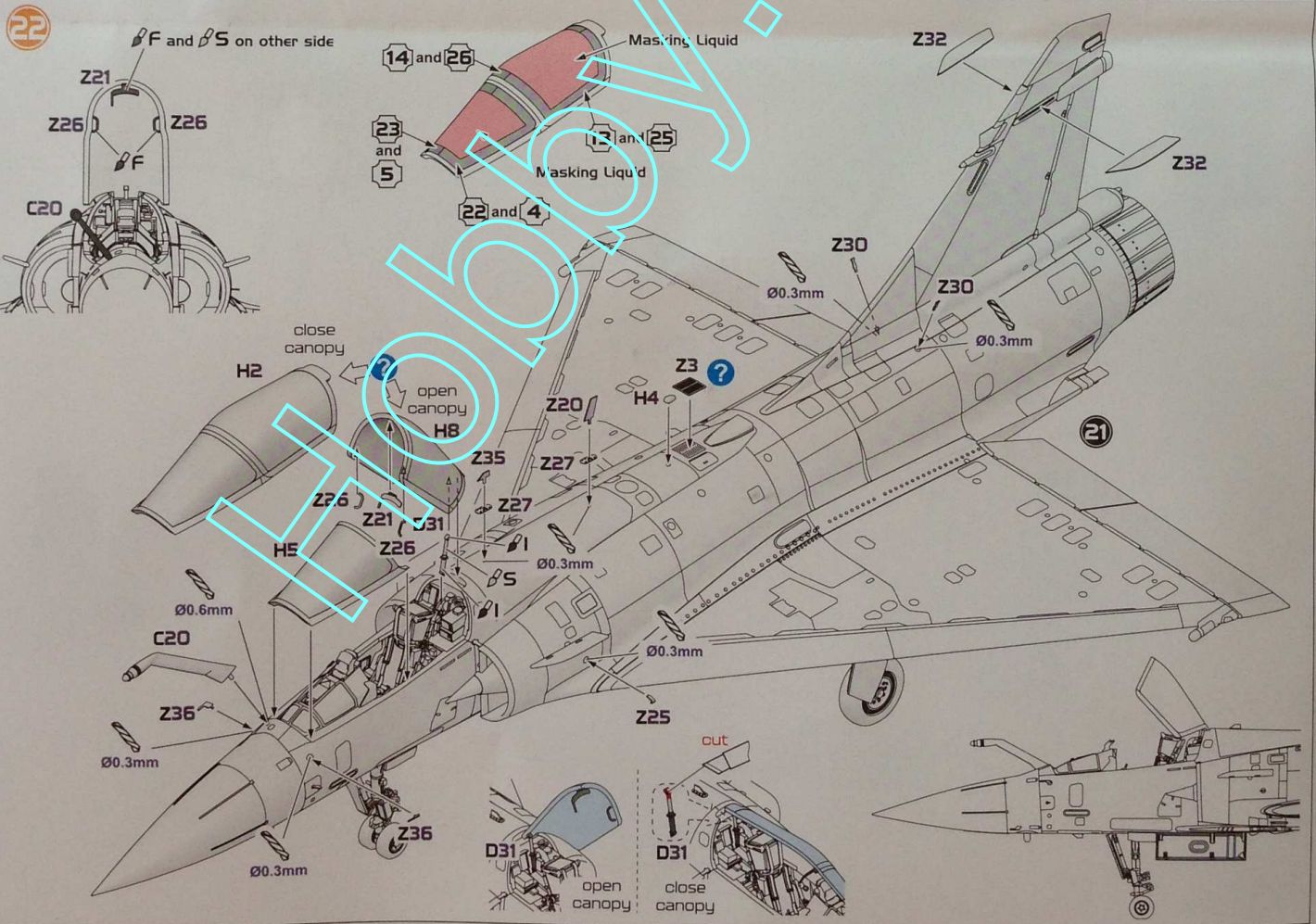
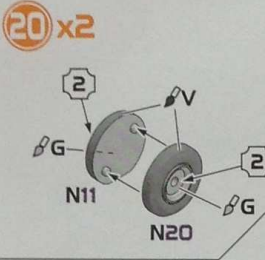
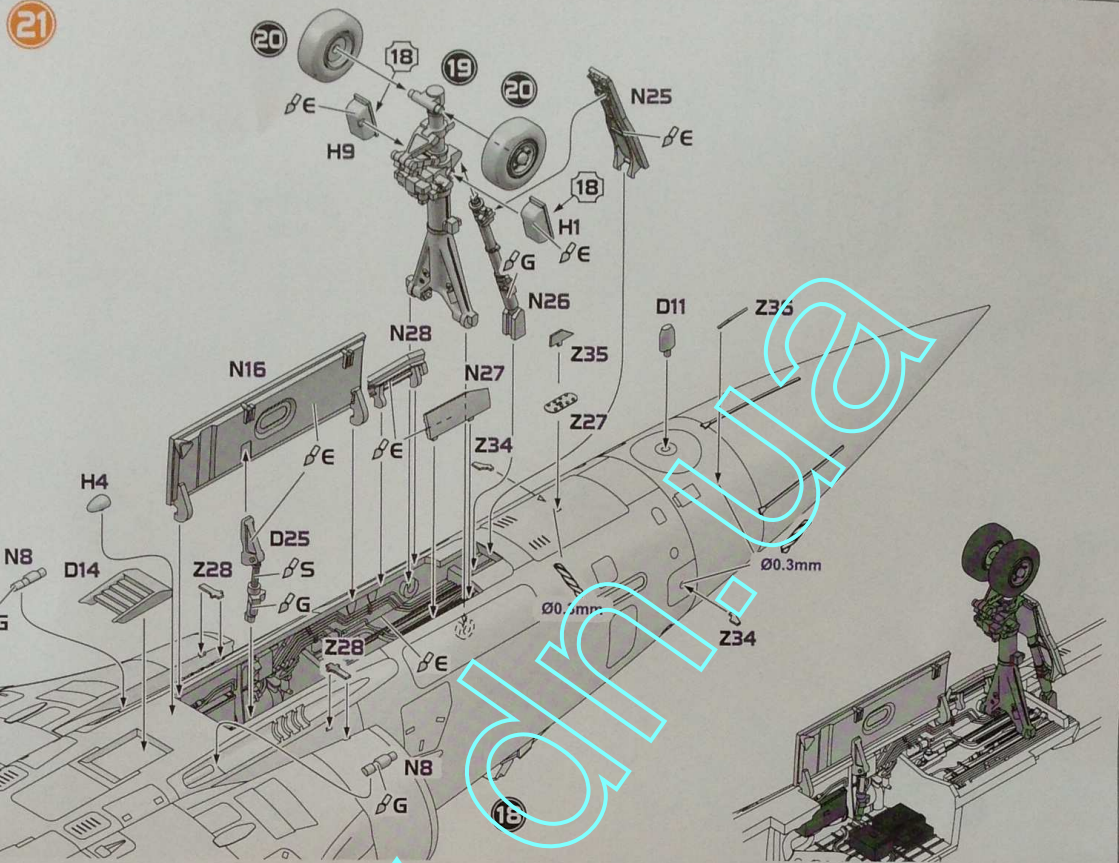
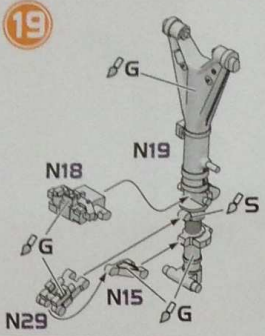
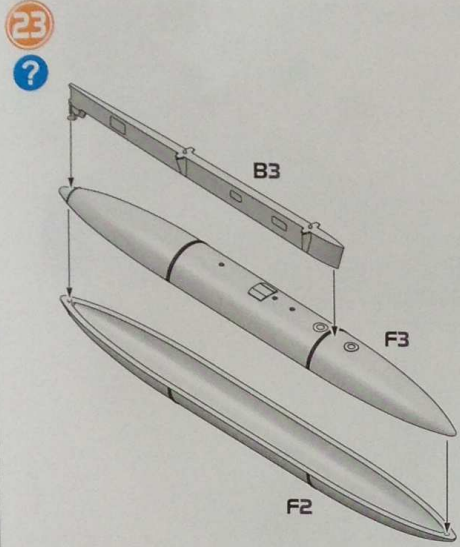
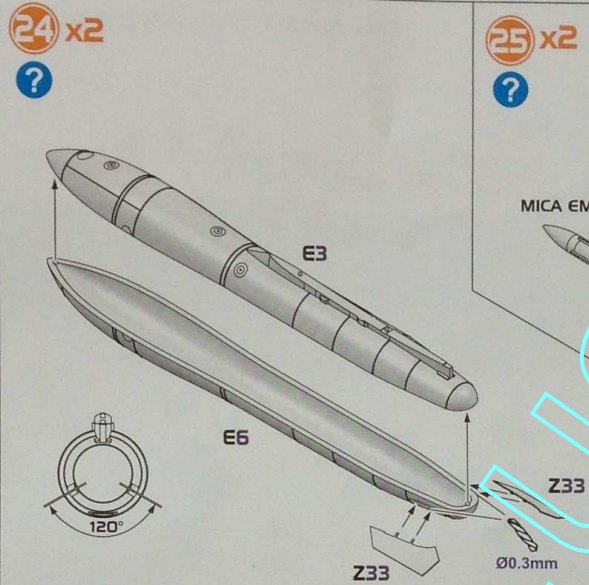

RP-541/542
2000L
Fuel Tank

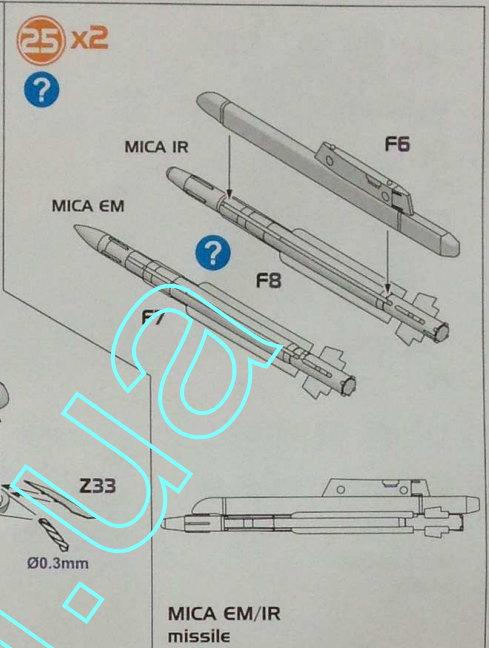

MICA EM/IR
missile





Схема розфарбування / Painting scheme

1 Mirage 2000-5F, EC 3/11 "Corse", BA 188 "Colonel Massart", Djibouti, 2014

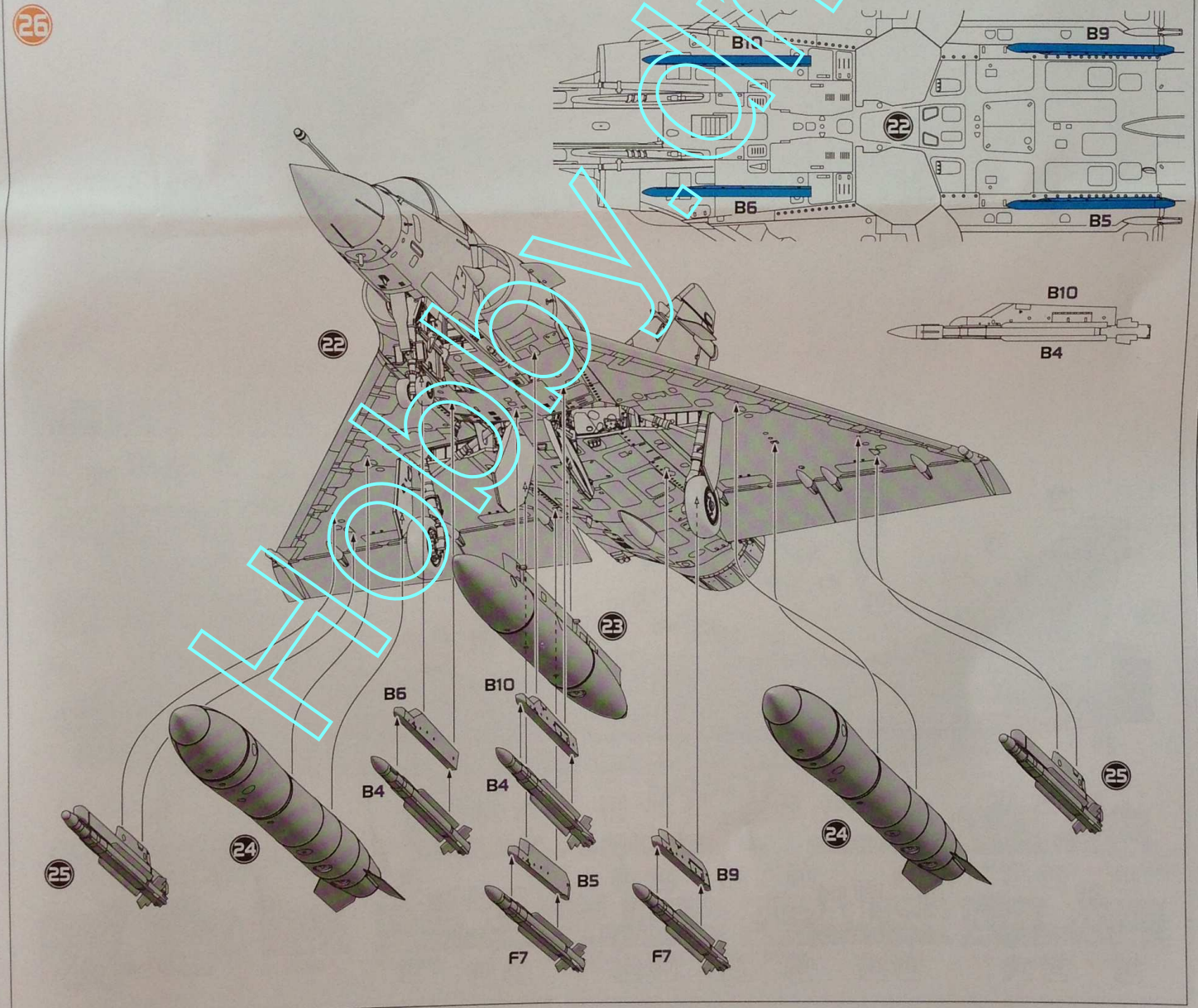

A Intermediate Blue
Mr.Color C366
AK RC235

B Light Ghost Grey
Mr.Color C308
AK RC252

E Light Grey
Mr.Color C338
AK RC253

F Dark Gull Grey
Mr.Color C317
AK RC247

G Aluminium
Mr.Met.Color MC218
AK Xtr.Met. - AK479

I Flat Black
Mr.Color C33
AK RC001

J Pale Yellow
Mr.Color C313
AK RC018

K White
Mr.Color C62
AK RC004

R Burnt Metal
Mr.Color C61
AK Xtr.Met. - AK484

V Rubber/Tires
Mr.Color C137
AK RC022

X Grey
Mr.Color C306
AK RC249

T Steel
Mr.Met.Color MC213
AK Xtr.Met. - AK476



Схема розфарбування / Painting scheme

2 Mirage 2000-5F, EC 1/2 "Cigognes", Souda Bay, Crete. 31 March, 2011
Opération Harmattan . Operation "Unified Protector"

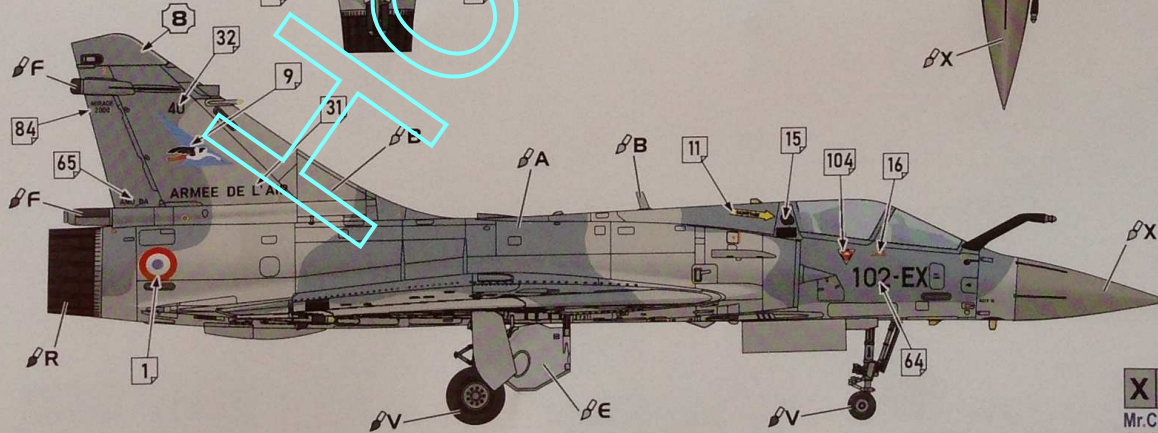
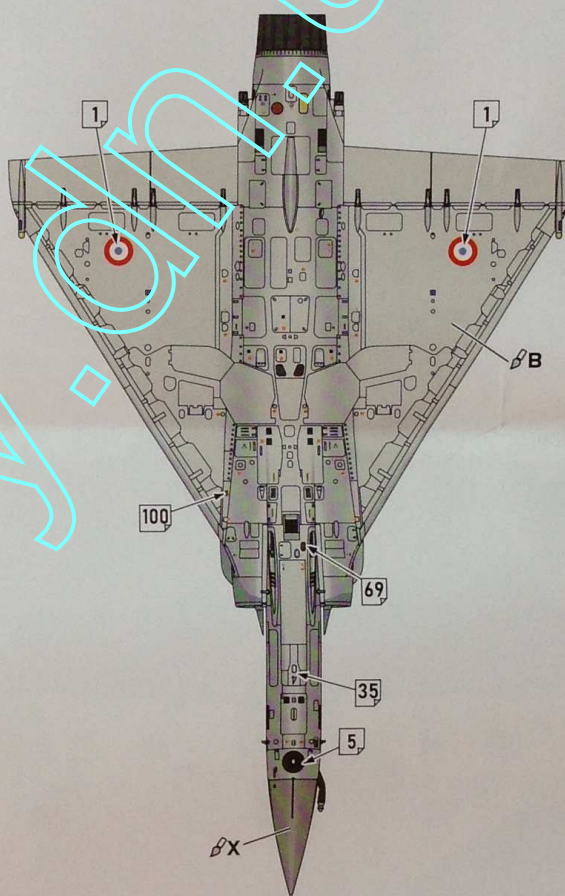
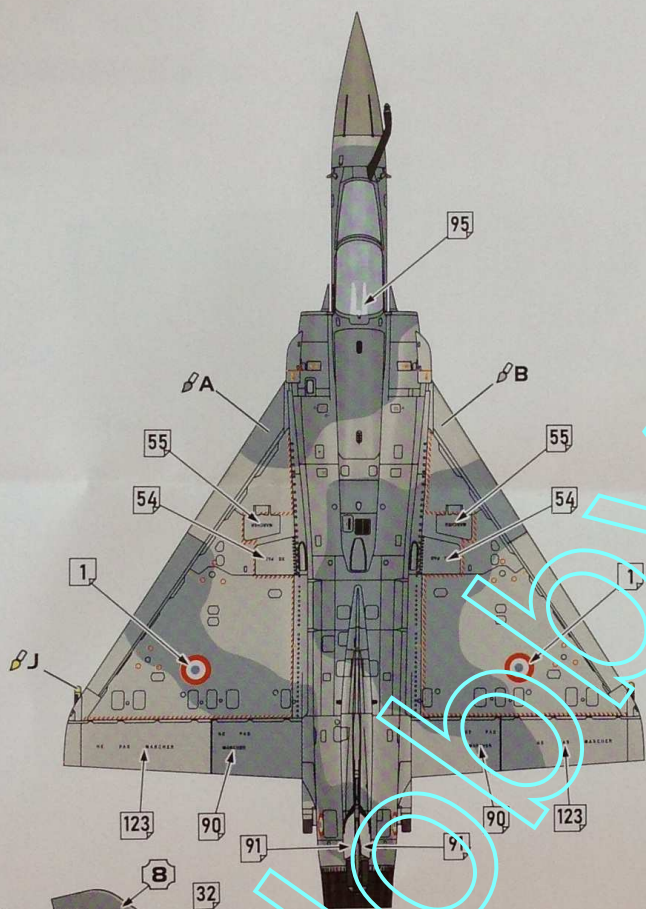
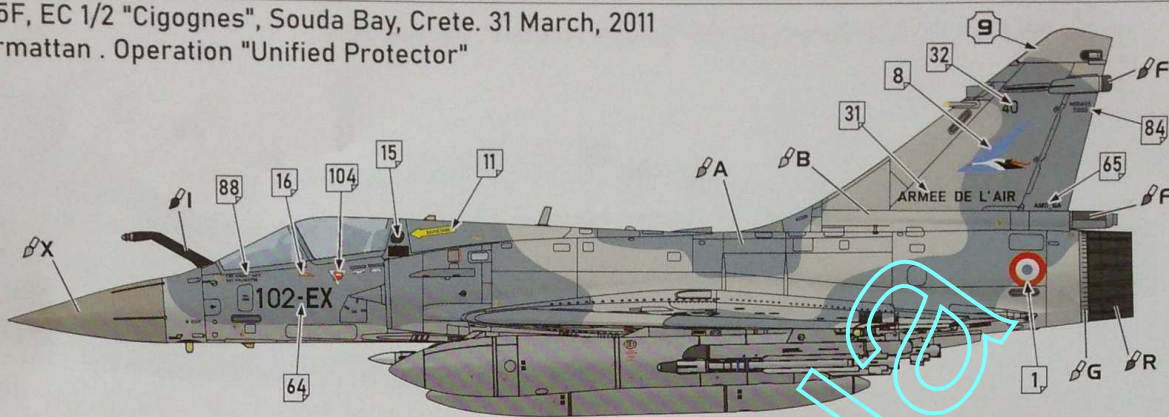

A Intermediate Blue
Mr.Color C366
AK RC235

B Light Ghost Grey
Mr.Color C308
AK RC252

E Light Grey
Mr.Color C338
AK RC253

F Dark Gull Grey
Mr.Color C317
AK RC247

G Aluminium
Mr.Met.Color MC218
AK Xtr.Met.- AK479

I Flat Black
Mr.Color C33
AK RC001

J Pale Yellow
Mr.Color C313
AK RC018

K White
Mr.Color C62
AK RC004

R Burnt Metal
Mr.Color C61
AK Xtr.Met.- AK484

V Rubber/Tires
Mr.Color C137
AK RC022

X Grey
Mr.Color C306
AK RC249

T Steel
Mr.Met.Color MC213
AK Xtr.Met.- AK476



Схема розфарбування / Painting scheme

3 Mirage 2000-5F, "Low Viz", 50 Ans EC 2/2 "Cote d'Or", BA 102, Dijon AFB, 2000

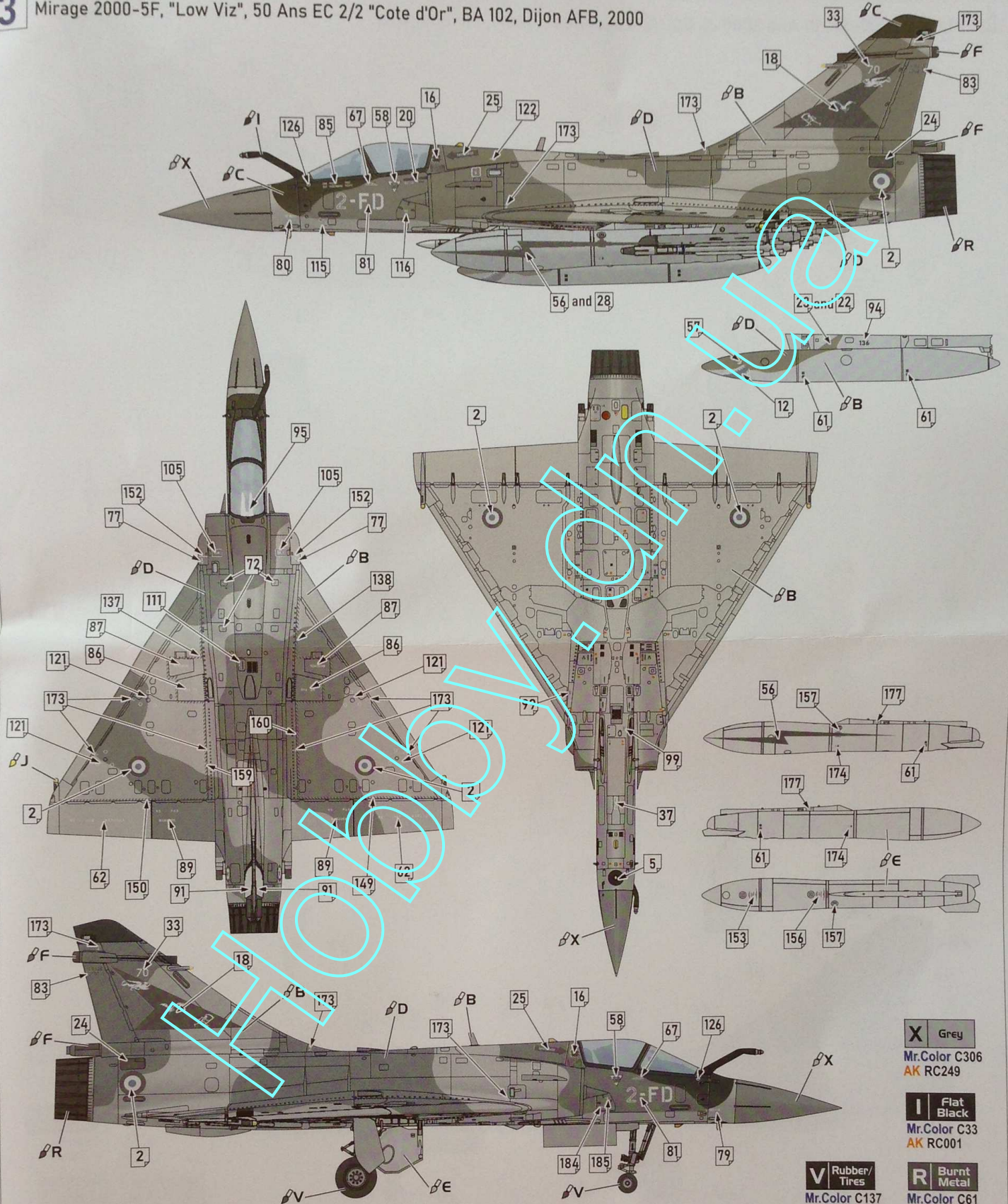

A Intermediate Blue
Mr.Color C366
AK RC235

B Light Ghost Grey
Mr.Color C308
AK RC252

C Dark Grey
Mr.Color C32
AK RC251

D Grey
Mr.Color C31
AK RC251

E Light Grey
Mr.Color C338
AK RC253

F Dark Gull Grey
Mr.Color C317
AK RC247

G Aluminium
Mr.Met.Color MC218
AK Xtr.Met.- AK479

J Pale Yellow
Mr.Color C313
AK RC018

K White
Mr.Color C62
AK RC004

X Grey
Mr.Color C306
AK RC249

I Flat Black
Mr.Color C33
AK RC001

V Rubber/Tires
Mr.Color C137
AK RC022

R Burnt Metal
Mr.Color C61
AK Xtr.Met.- AK484

4 Mirage 2000-5F, 10 Ans 2000-5, EC 1/2 "Cigognes", BA116, Luxeuil, 2019

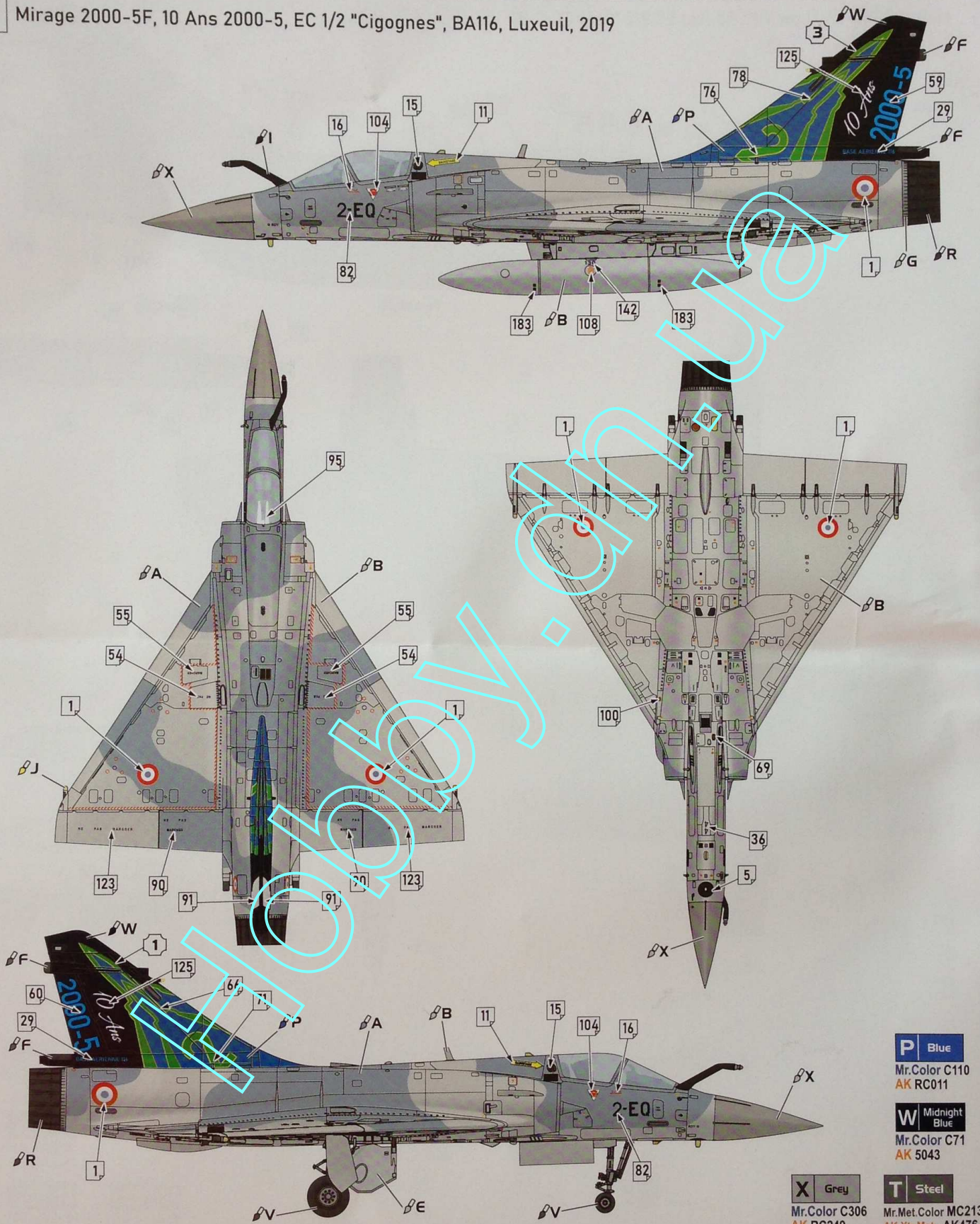

- | | | | | | | | | | |
|---|--|--|--|--|---|---|--|--|--|
| A Intermediate Blue
Mr.Color C366
AK RC235 | B Light Ghost Grey
Mr.Color C308
AK RC252 | E Light Grey
Mr.Color C338
AK RC253 | F Dark Gull Grey
Mr.Color C317
AK RC247 | G Aluminium
Mr.Met.Color MC218
AK Xtr.Met.- AK479 | I Flat Black
Mr.Color C33
AK RC001 | J Pale Yellow
Mr.Color C313
AK RC018 | K White
Mr.Color C62
AK RC004 | R Burnt Metal
Mr.Color C61
AK Xtr.Met.- AK484 | V Rubber/Tires
Mr.Color C137
AK RC022 |
|---|--|--|--|--|---|---|--|--|--|

- | |
|--|
| P Blue
Mr.Color C110
AK RC011 |
| W Midnight Blue
Mr.Color C71
AK 5043 |
| X Grey
Mr.Color C306
AK RC249 |
| T Steel
Mr.Met.Color MC213
AK Xtr.Met.- AK476 |