

Mirage 2000C



CAT. NO 72073



SCALE
1:72

SPAN: 127 mm
LENGTH: 199 mm
PARTS: 163 pieces

ЗБІРНА МОДЕЛЬ \ ЛІМІТОВАНИЙ ВИПУСК
PLASTIC MODEL KIT \ LIMITED EDITION



Освіцілене тактико-технічне завдання на третє покоління літака з дельтовидним крилом було вигано в березні 1976 р. Літак Mirage-2000 зробили нестійким по тангажу з електрогідрастатичною системою управління. Крило мало невелике підйомне навантаження на крило та автоматичні щільні предкрилки по всьому розмаху. Mirage-2000 оснастили двигуном SNECMA M53. Прототип виконав перший політ 10 березня 1978 р. За результатами випробувань встановили киль зі збільшеною хордою і змінили стик крила і фюзеляжу.

Перший серійний Mirage-2000C піднявся в небо 20 листопада 1982 р. Перша партія складалася з 36 літаків.

Поставка в війська одномісного перехоплювача Mirage-2000C почалася в квітні 1983 р. Mirage-2000C комплектувався знімним паливоприймачем системи дозаправки в польоті. У нижній частині фюзеляжу літака під носом розтабували чотири встановлені дві гармати DEFA 554 (30 мм по 150 снарядів). Були дев'ять вузлів пілвіски озброєння, для пілвіски бомб, ракет, гонголи з ракетозвідним устаткуванням, ракетні або гарматні контейнери, паливні баки сумарною масою до 6300 кг. 136 літаків Mirage-2000C експортувалися з Франції країні світу. 37 літаків Mirage-2000C з RDI модернізували в варіант Mirage-2000-SF для ВПС Франції.



The Mirage 2000 was a result of Dassault design work on the official tactical and technical requirements of French Air Force for 3rd generation fighter, announced in March 1976.

In the Mirage 2000 project, Dassault engineers managed to bring the delta wing up to date by moving the aircraft's center of lift to the front of its center of gravity, giving the fighter a degree of instability that enhanced maneuverability. That also allowed the take-off run.

Mirage 2000 featured a redundant "fly-by-wire automatic flight control system (FBW AFCS)", providing electronic "smarts" to compensate for the aircraft's inherent instability; two-piece elevons on each wing; and automatic, full-length, two-segment leading-edge slats. That gave the Mirage 2000 a level of agility that the Mirage III and 5 lacked, and in fact the new machine acquired a reputation for "superb handling". An airbrake was fitted on top of each wing, the arrangement being very similar to that of the Mirage III. A noticeably taller tailfin allowed the pilot to retain control at higher angles of attack, assisted by small strakes mounted along each air intake.

Mirage 2000 initially was powered by single SNECMA M53-5 jet engine, rated at 88 kN (20,000 lbf) of thrust with afterburner.

The first prototype made its maiden flight on 10th of March 1978 with Jean Coreau at the controls. There were 4 single-seat prototypes, including the first Mirage 2000 prototype mentioned above. The first production Mirage 2000C flew in November 1982. Initial deliveries were in 1983. The first operational squadron was formed in 1984, just in time for the 50th anniversary of the French Air Force.

French Air force received its total 124 Mirage 2000C, 37 of which have been upgraded to the Mirage-2000-SF variant.

НЕОБХІДНІ ФАРБИ \ REQUIRED PAINTS

A Intermediate Blue Mr.Color C366 AK RC235	B Light Ghost Grey Mr.Color C308 AK RC252	C Dark Grey Mr.Color C310 AK RC215	D Sand Mr.Color C119+C62 AK RC104	E Light Grey Mr.Color C338 AK RC253	F Dark Gull Grey Mr.Color C317 AK RC247	G Aluminium Mr.Met.Color MC218 AK Xtr.Met.- AK479	H Gun Metal Mr.Met.Color MC214 AK Xtr.Met.- AK483	I Flat Black Mr.Color C33 AK RC001
J Pale Yellow Mr.Color C313 AK RC018	K White Mr.Color C62 AK RC004	L Red Mr.Color C47 AK RC503	M Khaki Mr.Color C55 AK RC096	N Green Mr.Color C303 AK 2303	O Yellow Mr.Color C4 AK RC007	P Blue Mr.Color C110 AK RC011	R Burnt Metal Mr.Color C61 AK Xtr.Met.- AK484	S Chrom Silver Mr.Met.Color MC211 AK Xtr.Met.- AK477
T Steel Mr.Met.Color MC213 AK Xtr.Met.- AK476	U Zinc Chromate Mr.Color C351 AK RC028	V Rubber/Tires Mr.Color C137 AK RC022	Z Hull Red Mr.Color C029 AK RC067					

УМОВНІ СИМВОЛИ \ USED SYMBOLS

1 ЕТАПИ ЗБИРАННЯ STAGES OF ASSEMBLY	A1 НОМЕР ДЕТАЛІ PART NUMBER	1 ОКРЕМІ ДЕТАЛІ SEPARATE DETAILS	1 НАКЛІЙТИ ДЕКАЛІ APPLY DECALS	1 НАКЛІЙТИ МАСКУ APPLY THE ADHESIVE MASK	? НА ВИБІР OPTIONAL
A ВАРІАНТИ ДЛЯ ЗБИРАННЯ VARIANTS OF ASSEMBLY	PS КЛІЙТИ НА СУПЕРКЛЕЙ GLUE ON "SUPER GLUE"	X НЕ КЛІЙТИ DON'T GLUE	○ ЗРОБИТИ ОТВІР MAKE A HOLE	△ ВІДРІЗАТИ НОЖЕМ DETACH WITH KNIFE	A ФАРБУВАТИ TO PAINT

Модель вироблена за технологією «short run»
і призначена для досвідчених моделістів

This model is produced using short run technology,
designed for experienced modelers



Комплектність / Complete set

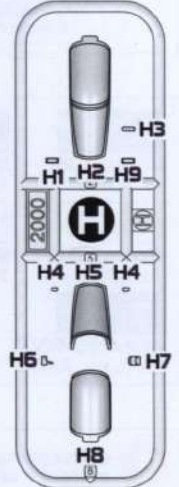
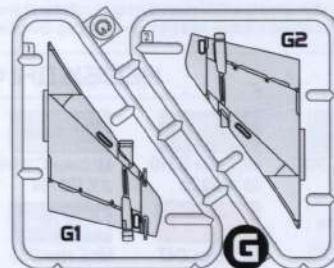
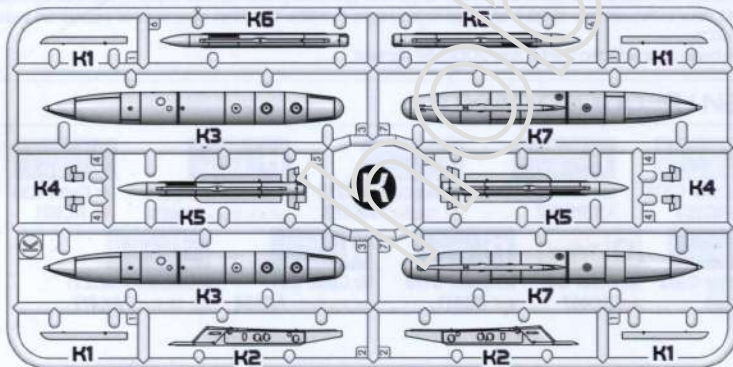
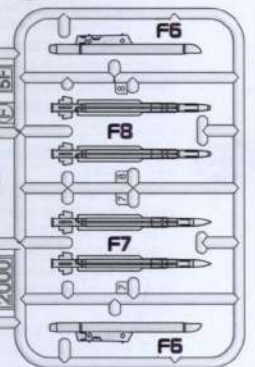
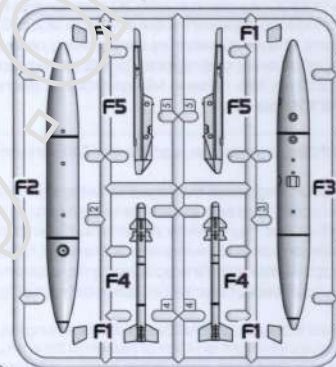
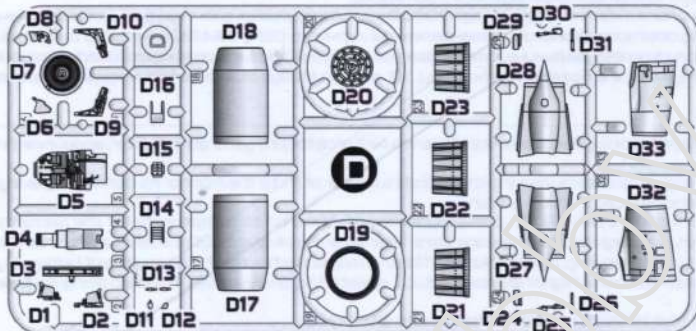
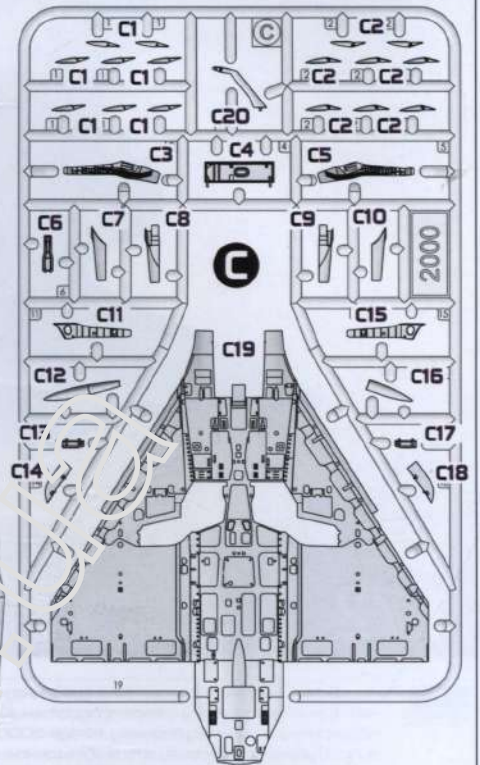
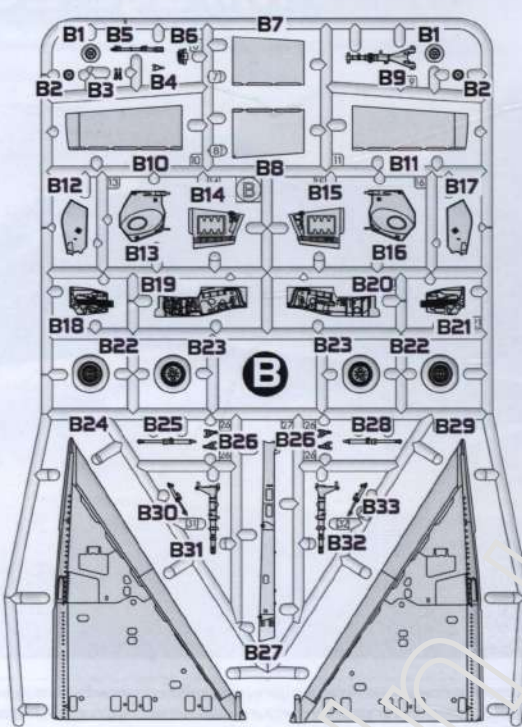
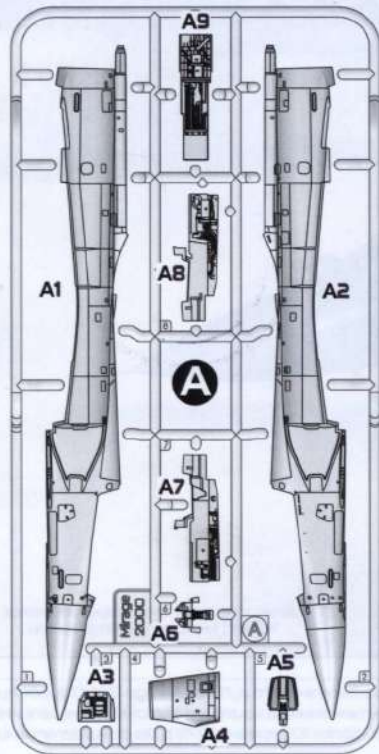

одна декаль для п'яти варіантів забарвлення
one decal for five versions of colouring

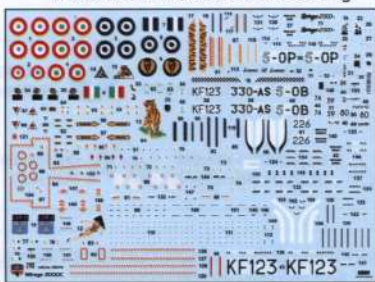

лист фотоетчу
photo-etched sheet

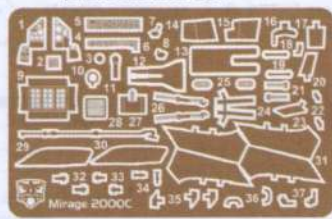

плівка з прозорими
гемальми
film with transparent
details

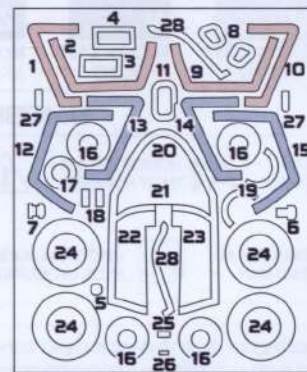

маски для фарбування
masks for painting

зовні
outside
всередині
inside



Схема збирання / The scheme of assembly





Схема збирання / The scheme of assembly



* Bukopuchamuu Micro Kristal Klear
Use Micro Kristal Klear

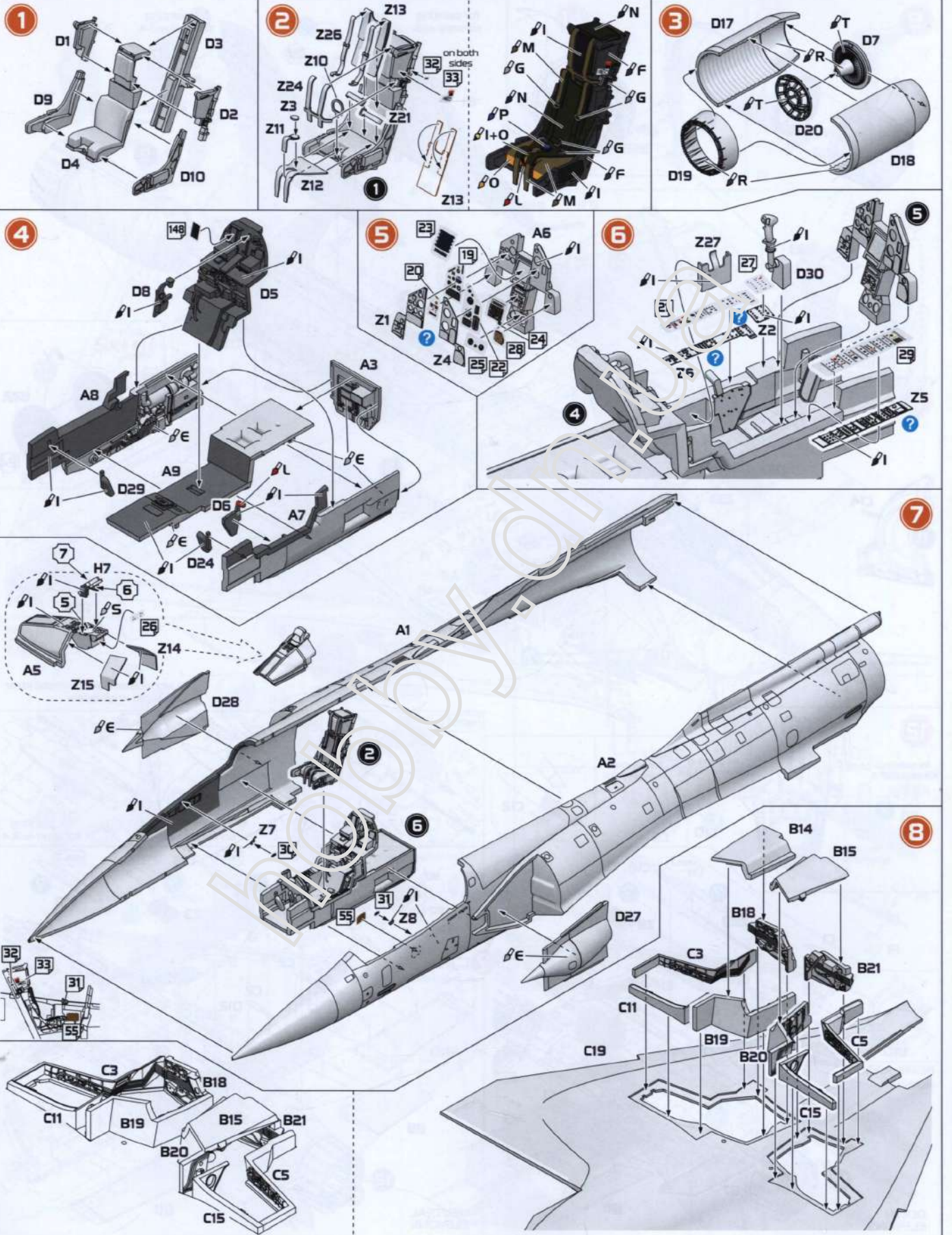
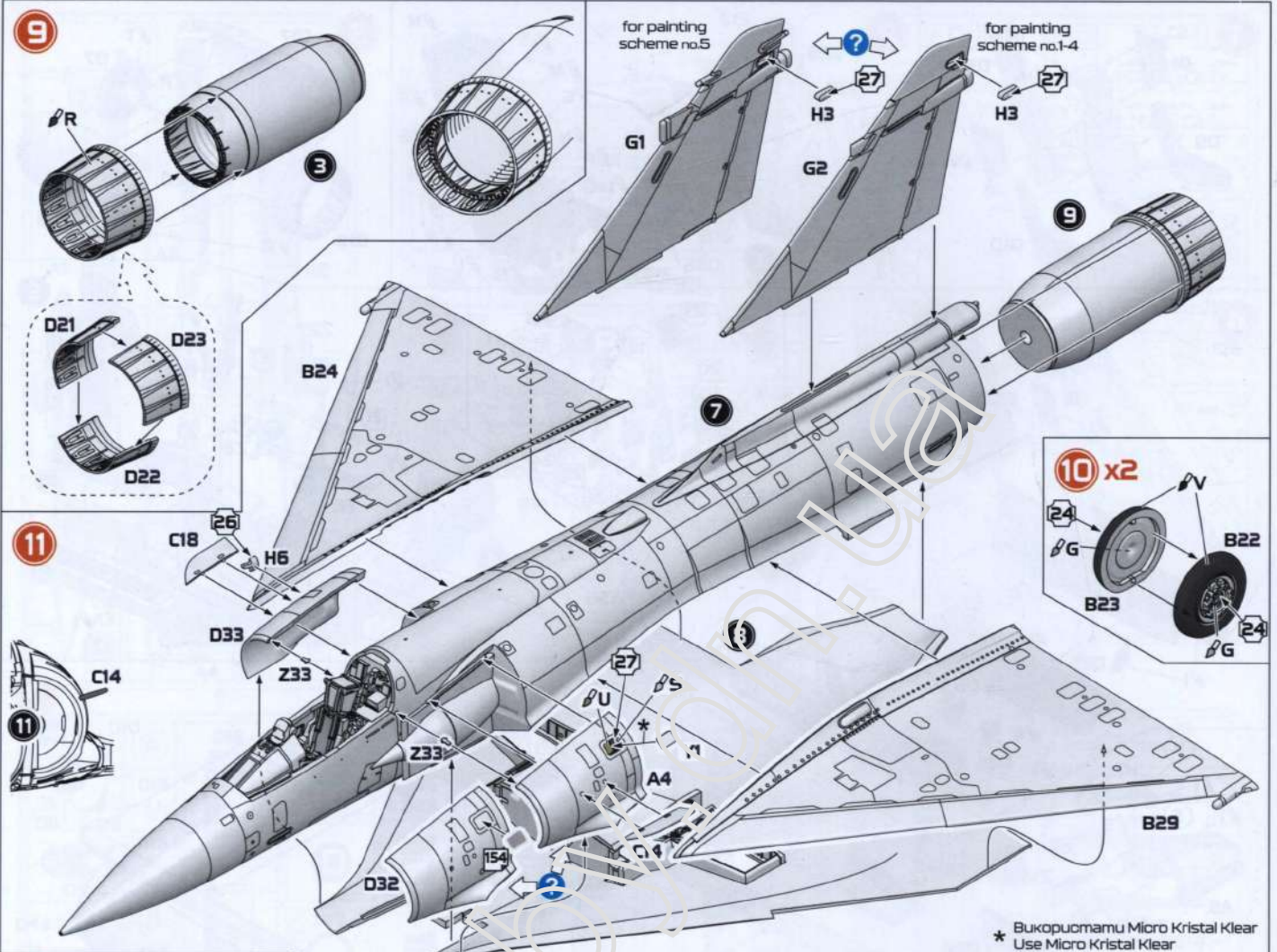



Схема збирання / The scheme of assembly



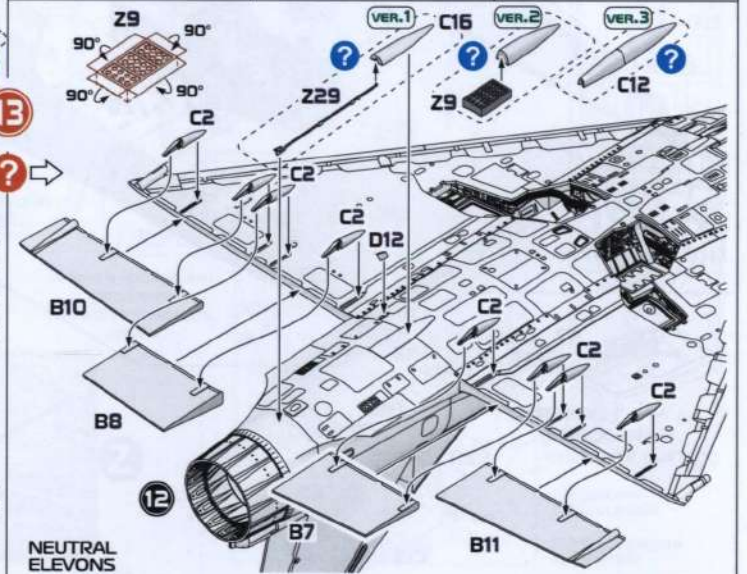
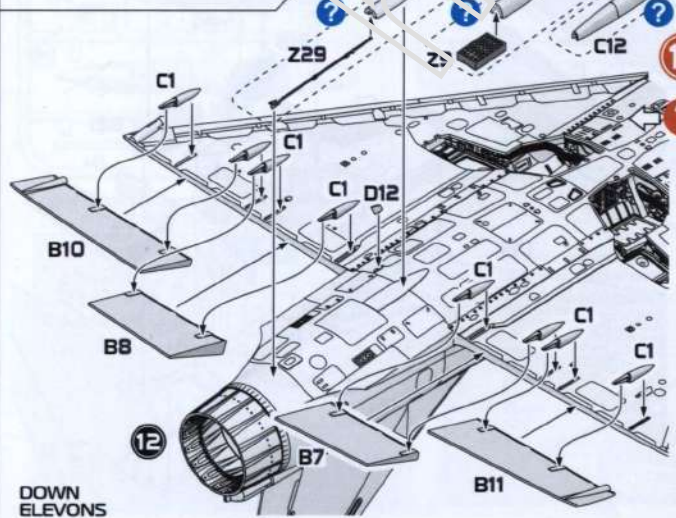
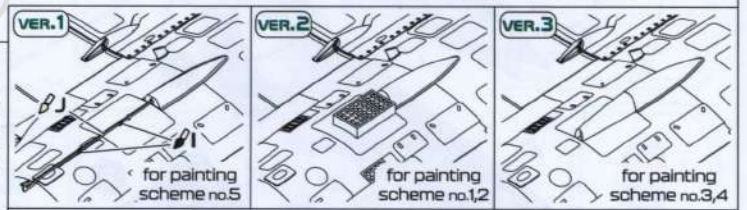
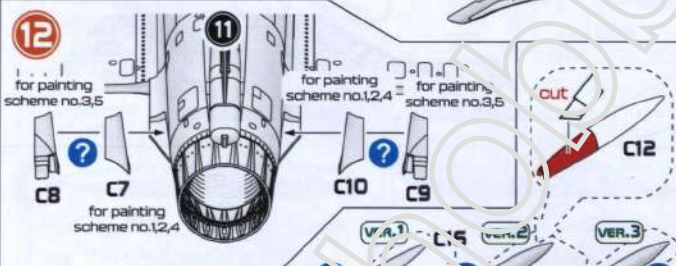

Схема збирання / The scheme of assembly



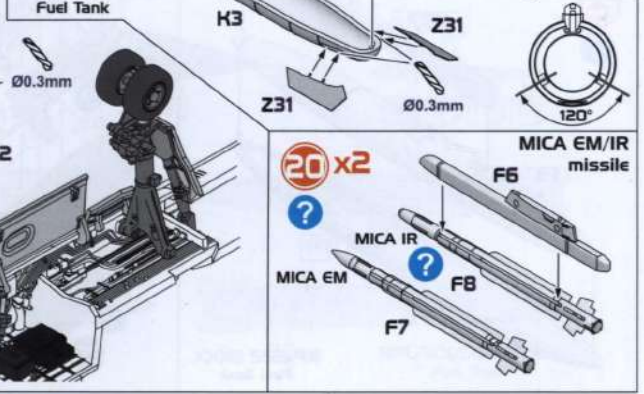
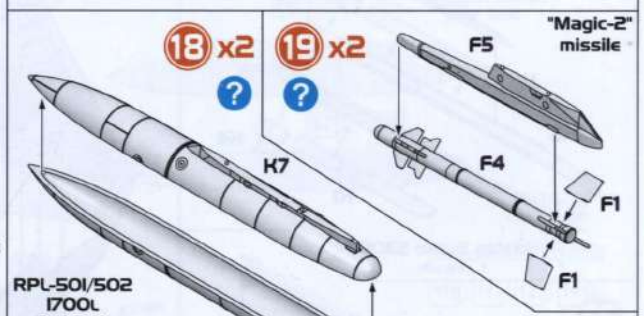
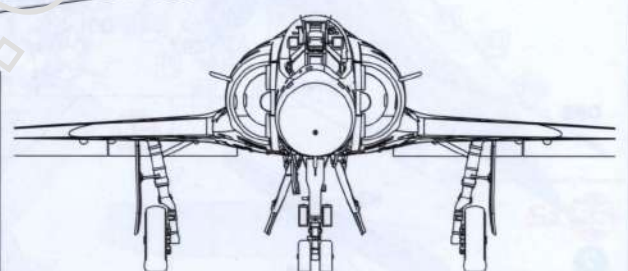
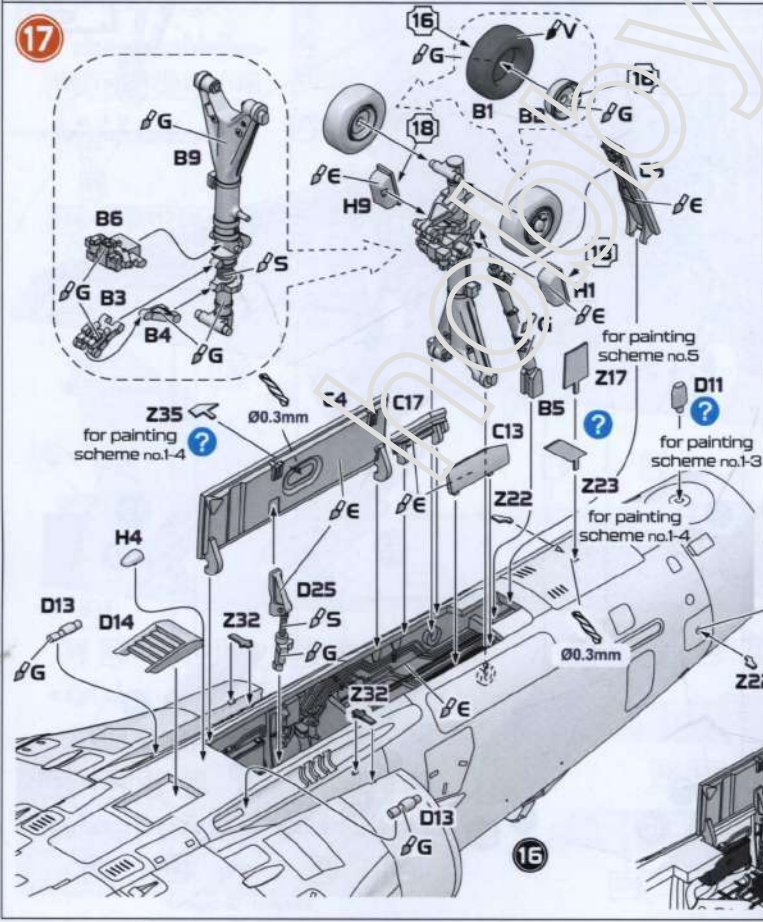
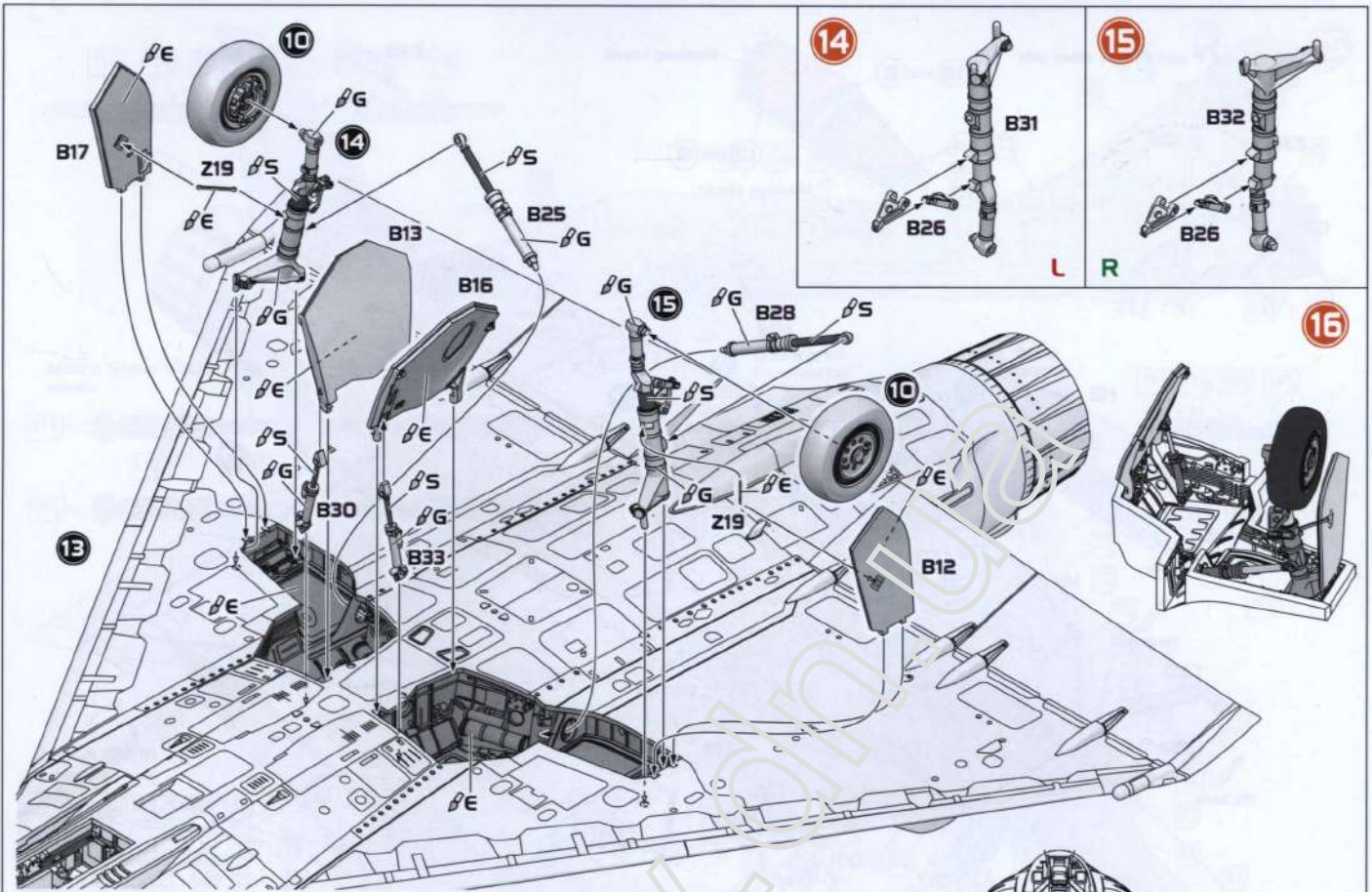
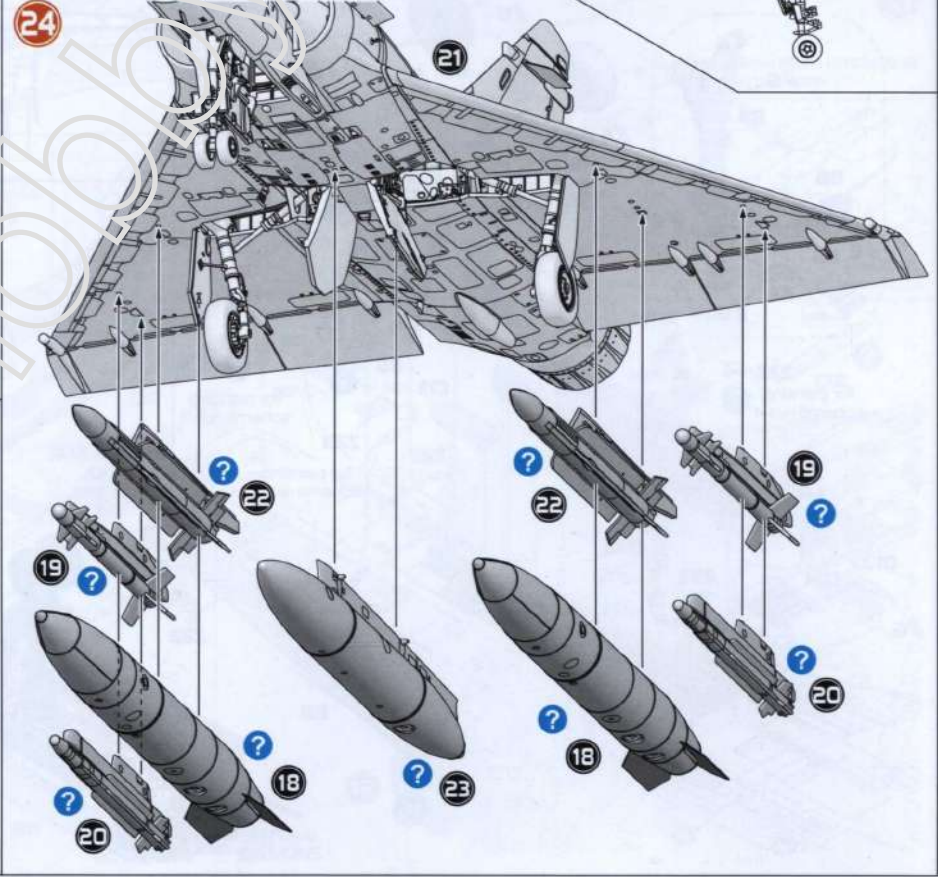
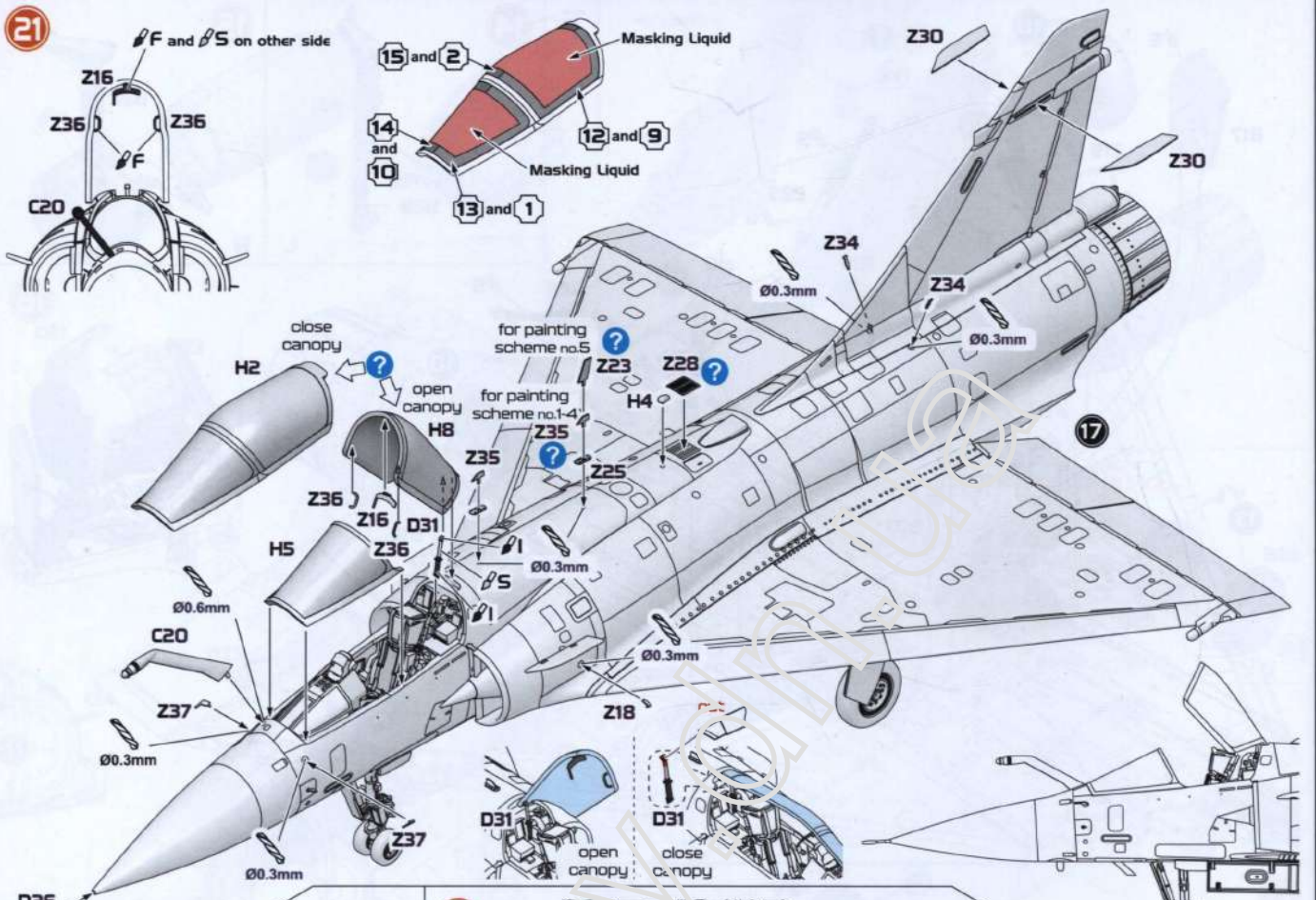

Технічні нагниси / Technical stencils





Схема розфарбування / Painting scheme

1 Mirage 2000C, 5-OB n° 59, E.C. 2/5 "Ile de France", Armée de l'Air, Orange, France - Al Ahsa, Saudi Arabia, 1990

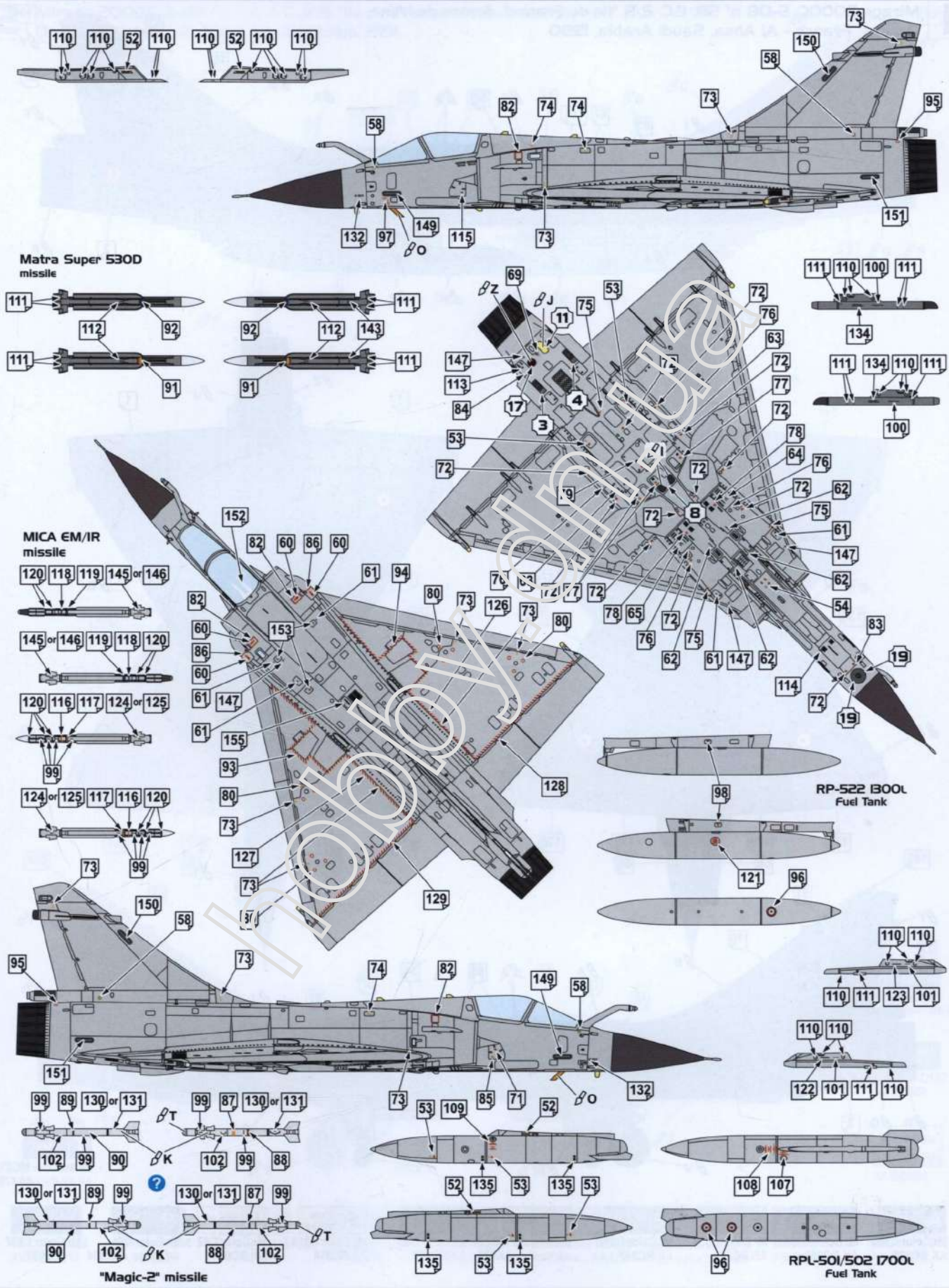
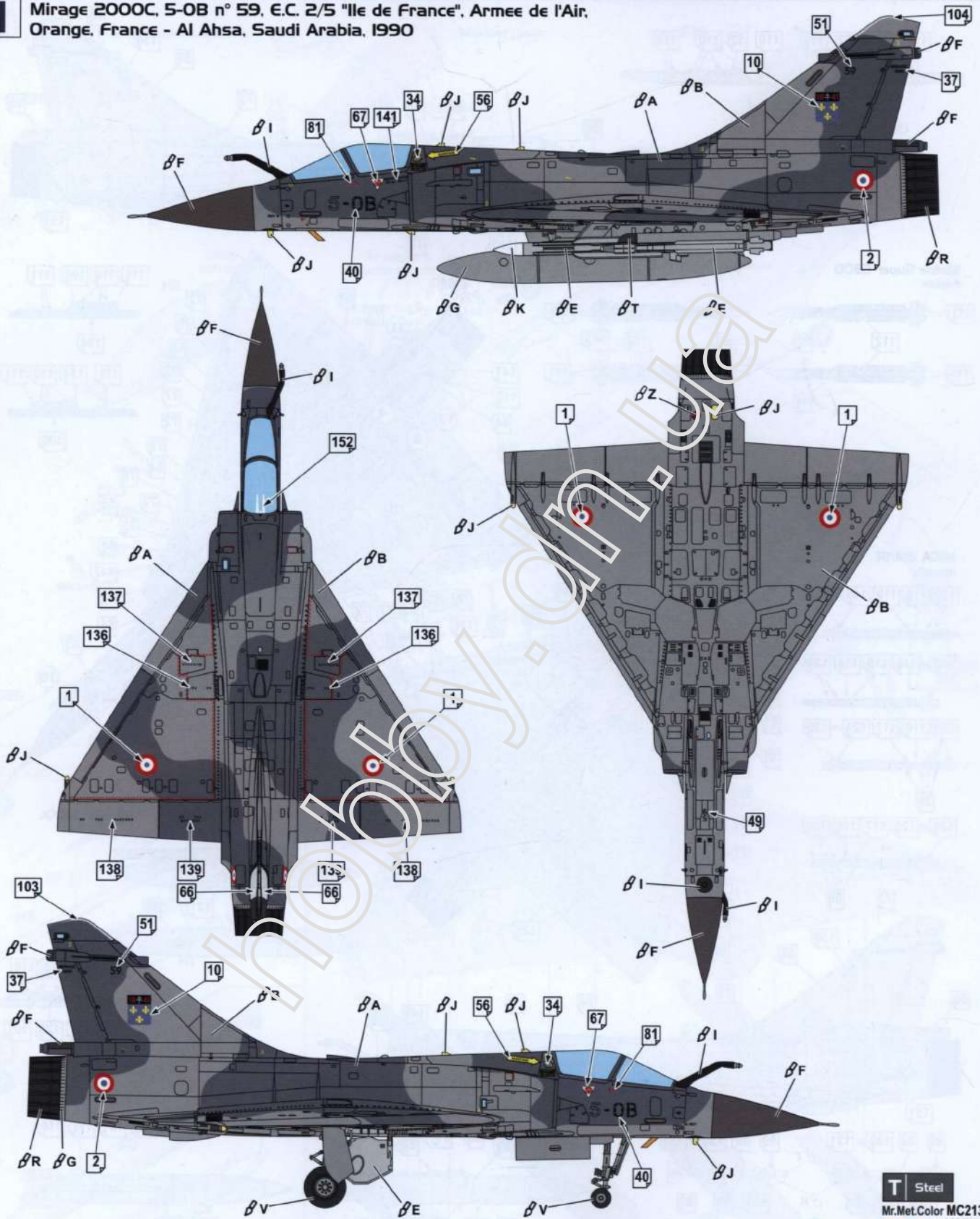

T Steel
Mr.Met.Color MC213
AK Xtr.Met.- AK476

- A** Intermediate Blue
Mr.Color C366
AK RC235
- B** Light Ghost Grey
Mr.Color C308
AK RC252
- E** Light Grey
Mr.Color C338
AK RC253
- F** Dark Gull Grey
Mr.Color C317
AK RC247
- G** Aluminium
Mr.Met.Color MC218
AK Xtr.Met.- AK479
- I** Flat Black
Mr.Color C33
AK RC001
- J** Pale Yellow
Mr.Color C313
AK RC018
- K** White
Mr.Color C62
AK RC004
- R** Burnt Metal
Mr.Color C61
AK Xtr.Met.- AK484
- V** Rubber/Tires
Mr.Color C137
AK RC022



Схема розфарбування / Painting scheme

2 Mirage 2000C, 5-OP n° 74, E.C. 2/5 "Ile de France", Armée de l'Air,
Orange, France - Al Ahsa, Saudi Arabia, 1991

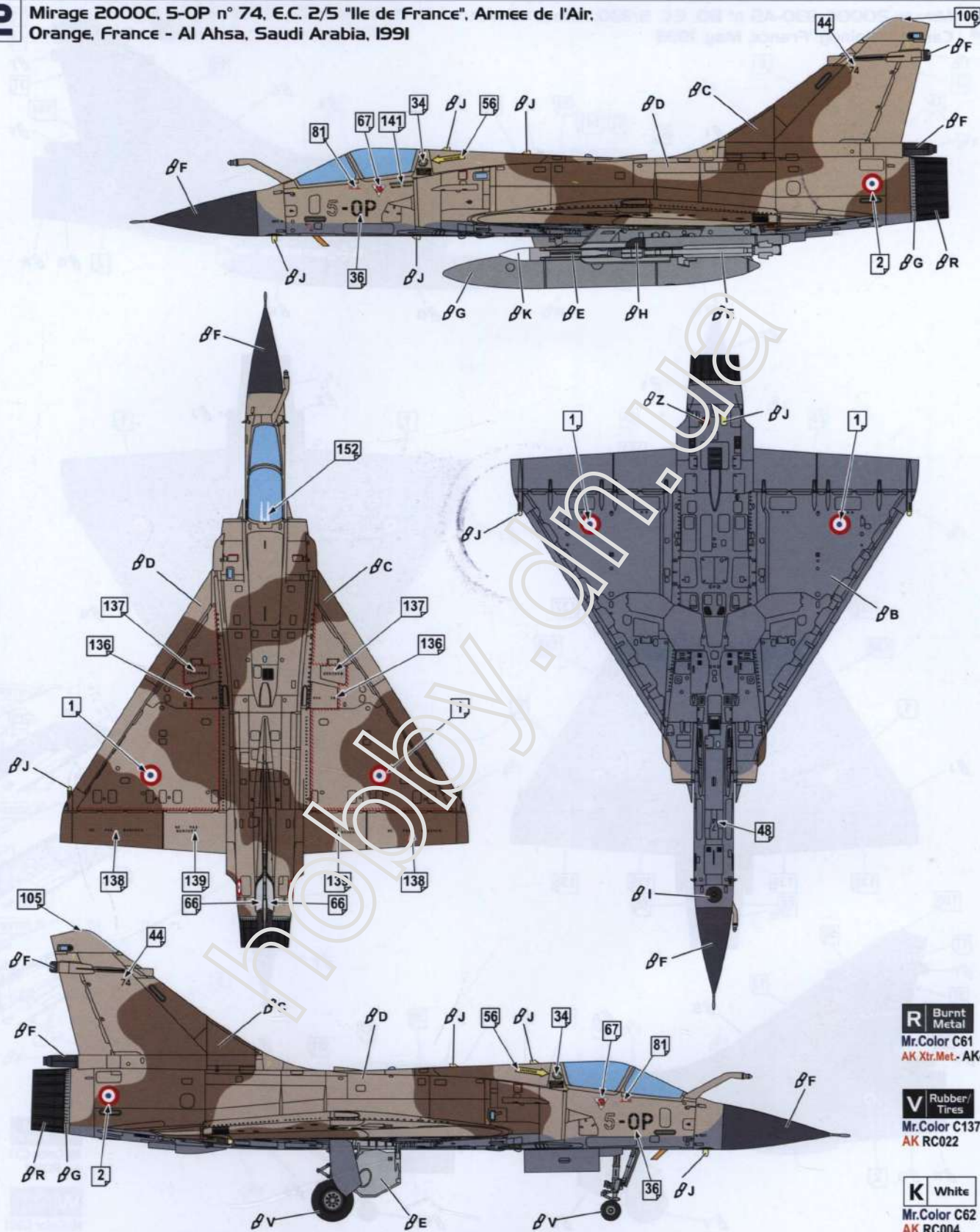

R Burnt Metal
Mr.Color C61
AK Xtr.Met.- AK484

V Rubber/Tires
Mr.Color C137
AK RC022

K White
Mr.Color C62
AK RC004

B Light Ghost Grey
Mr.Color C308
AK RC252

C Dark Tan
Mr.Color C310
AK RC225

D Sand
Mr.Color C119+C62
AK RC104

E Light Grey
Mr.Color C338
AK RC253

F Dark Gull Grey
Mr.Color C317
AK RC247

G Aluminium
Mr.Met.Color MC218
AK Xtr.Met.- AK479

H Gun Metal
Mr.Met.Color MC214
AK Xtr.Met.- AK483

I Flat Black
Mr.Color C33
AK RC001

J Pale Yellow
Mr.Color C313
AK RC018



Схема розфарбування / Painting scheme

3 Mirage 2000C, 330-AS n° 80. E.C. 5/330. Armée de l'Air, Cambrai-Epinoy, France, May, 1993

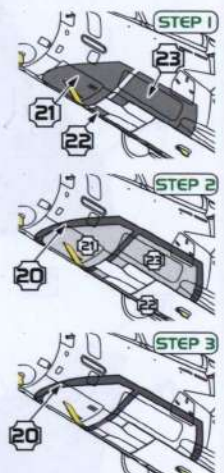
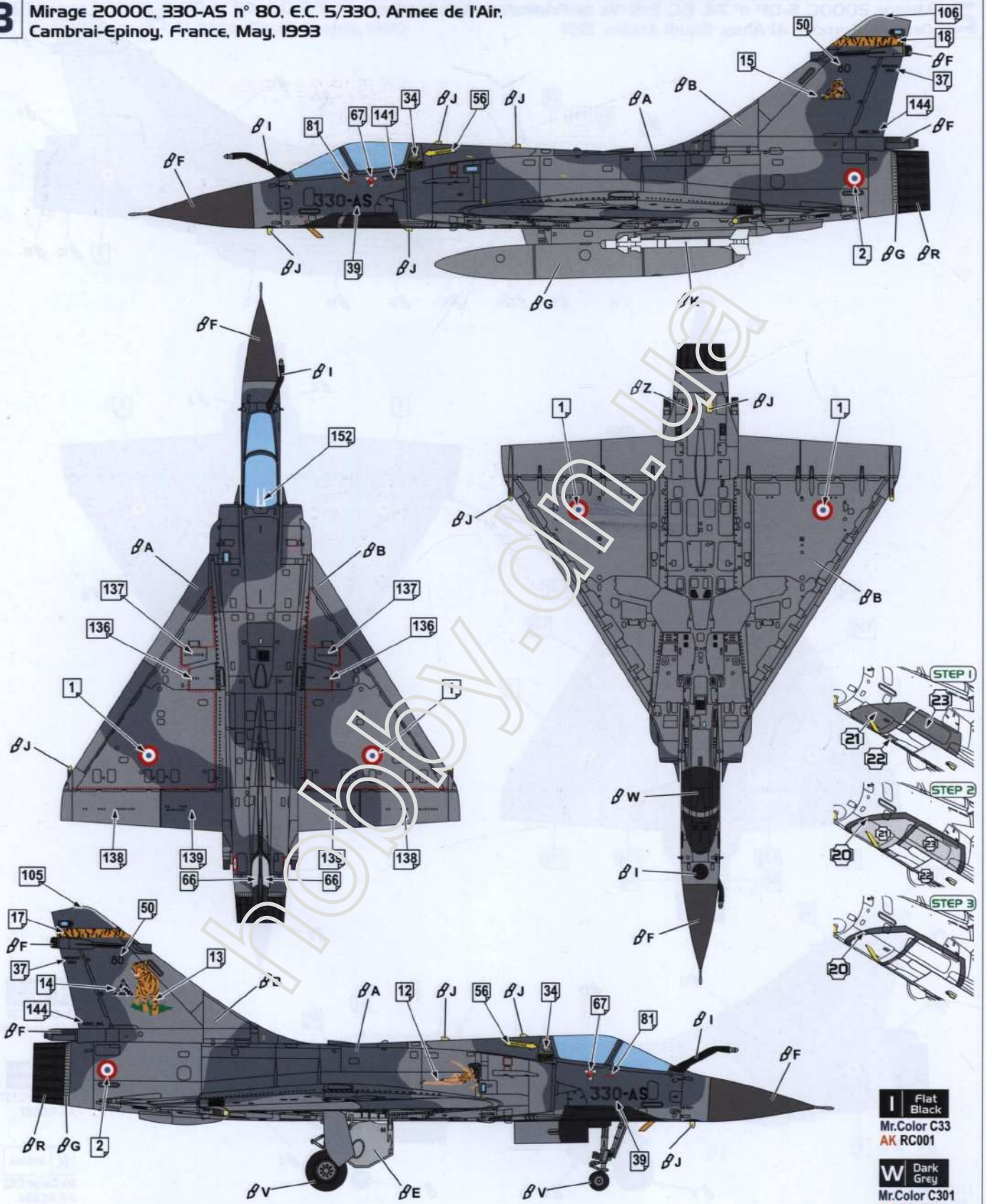

- A** Intermediate Blue
Mr.Color C366
AK RC235
- B** Light Ghost Grey
Mr.Color C308
AK RC252
- E** Light Grey
Mr.Color C338
AK RC253
- F** Dark Gull Grey
Mr.Color C317
AK RC247
- G** Aluminium
Mr.Met.Color MC218
AK Xtr.Met.- AK479
- J** Pale Yellow
Mr.Color C313
AK RC018
- K** White
Mr.Color C62
AK RC004
- V** Rubber/Tires
Mr.Color C137
AK RC022
- R** Burnt Metal
Mr.Color C61
AK Xtr.Met.- AK484

- I** Flat Black
Mr.Color C33
AK RC001
- W** Dark Grey
Mr.Color C301
AK RC243



Схема розфарбування / Painting scheme

4 Mirage 2000H, (Vajra) KFI23, 7th Squadron, Indian Air Force, Gwalior-Maharajpur, India, December 2012

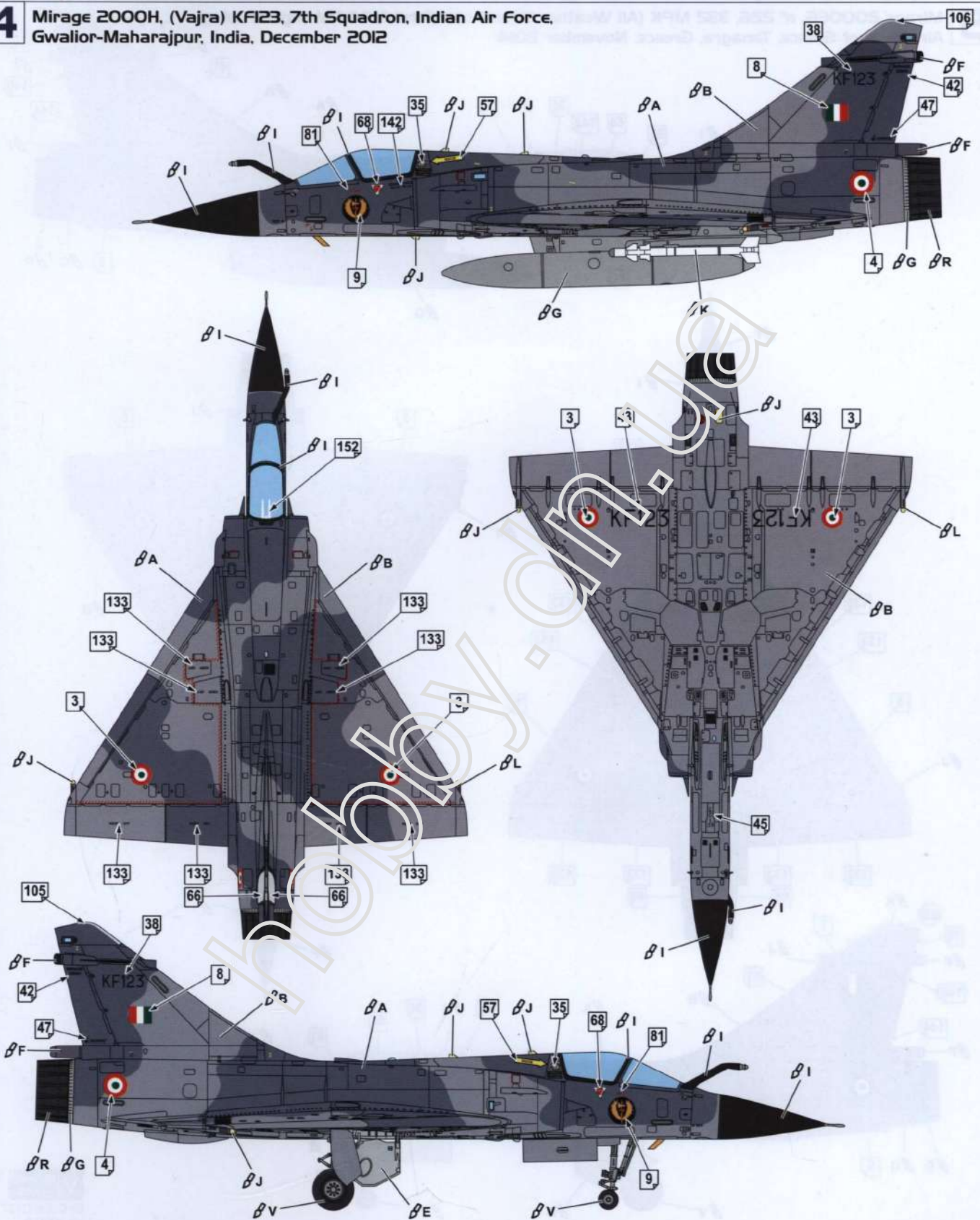

A Intermediate Blue Mr.Color C366 AK RC235	B Light Ghost Grey Mr.Color C308 AK RC252	E Light Grey Mr.Color C338 AK RC253	F Dark Gull Grey Mr.Color C317 AK RC247	G Aluminium Mr.Met.Color MC218 AK Xtr.Met. - AK479	I Flat Black Mr.Color C33 AK RC001	J Pale Yellow Mr.Color C313 AK RC018	K White Mr.Color C62 AK RC004	V Rubber/Tires Mr.Color C137 AK RC022	R Burnt Metal Mr.Color C61 AK Xtr.Met. - AK484
---------------------------------------------------------	--------------------------------------------------------	--------------------------------------------------	------------------------------------------------------	-----------------------------------------------------------------	-------------------------------------------------	---------------------------------------------------	--------------------------------------------	----------------------------------------------------	-------------------------------------------------------------



Схема розфарбування / Painting scheme

5 Mirage 2000EG, n° 226, 332 MPK (All Weather Squadron) 'Geraki', II4 PM (fighter wing), Air Force of Greece, Tanagra, Greece, November 2014

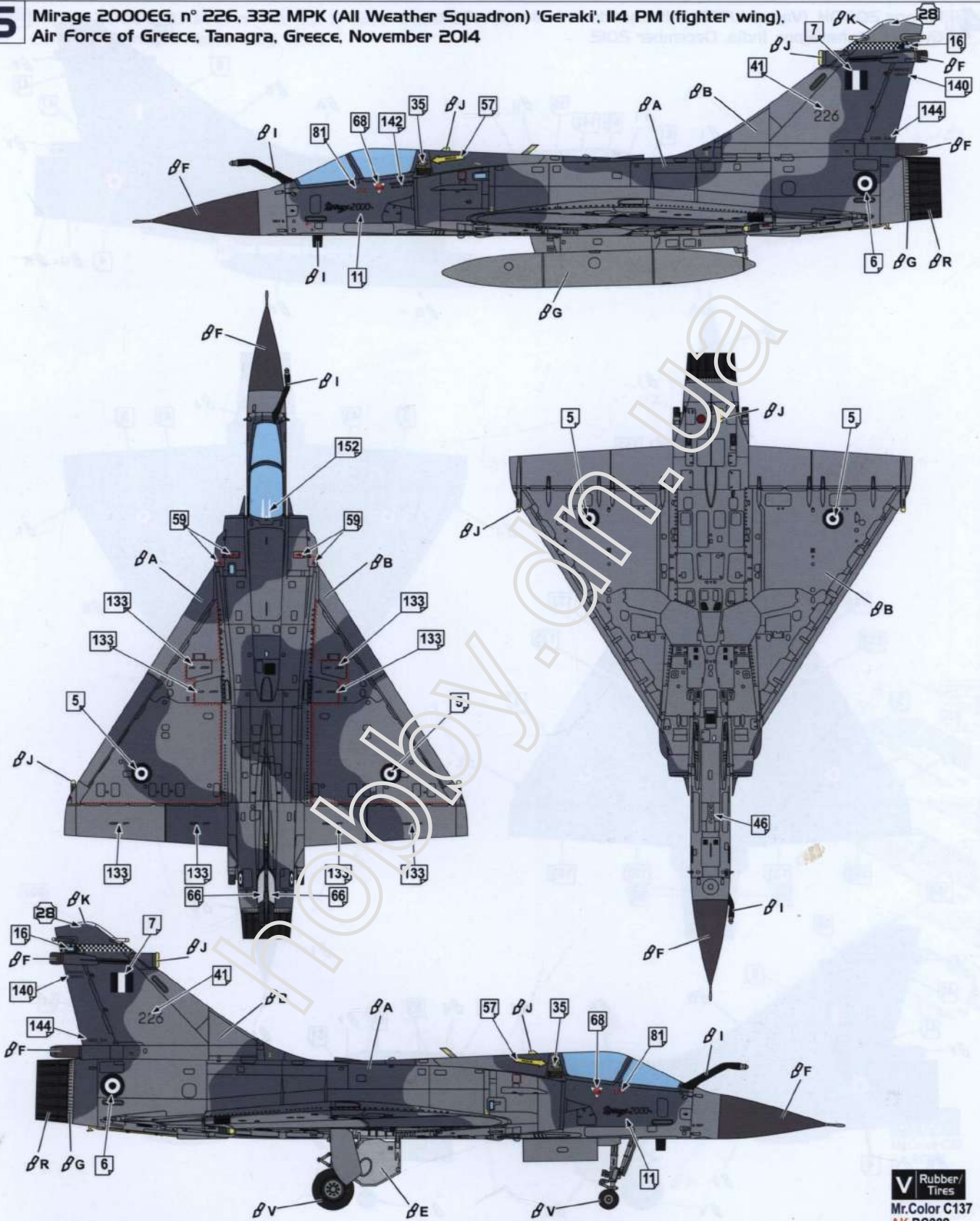

V Rubber/Tires
Mr.Color C137
AK RC022

A Intermediate Blue
Mr.Color C366
AK RC235

B Light Ghost Grey
Mr.Color C308
AK RC252

E Light Grey
Mr.Color C338
AK RC253

F Dark Gull Grey
Mr.Color C317
AK RC247

G Aluminium
Mr.Met.Color MC218
AK Xtr.Met.- AK479

H Gun Metal
Mr.Met.Color MC214
AK Xtr.Met.- AK483

I Flat Black
Mr.Color C33
AK RC001

J Pale Yellow
Mr.Color C313
AK RC018

K White
Mr.Color C62
AK RC004

R Burnt Metal
Mr.Color C61
AK Xtr.Met.- AK484