

Revell

GERMAN SUBMARINE

TYPE XXI with interior

05078-0389

© 2011 BY REVELL GmbH & Co. KG

PRINTED IN GERMANY

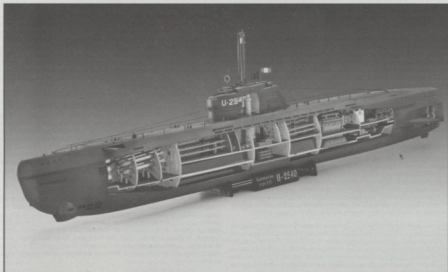

Deutsches U-Boot Typ XXI mit Interieur

Mit dem Typ XXI besaß Deutschland Anfang 1945 das fortschrittlichste U-Boot der damaligen Welt. Durch zahlreiche technische Neuerungen konnte es unbeschränkt unter Wasser fahren, da die Dieselmotoren die benötigte Frischluft durch einen speziellen Schnorchel ansaugten. Die für Unterwasserfahrten entworfene Linienform und eine dreifach größere Batteriekapazität ergaben eine sensationelle Unterwassergeschwindigkeit von 17 Knoten. Weitere Neuerungen waren geräuscharme Elektromotoren für Schleichfahrten, hochempfindliche Ortungsgeräte und 2 cm Flakgeschütztürme. Nach kurzer Ausbildungsfahrt wurde U2540 am 04.05.1945 von der Besatzung in der Flensburger Förde versenkt. 1957 wieder gehoben, diente es der Bundesmarine als Erprobungsboot „Wilhelm Bauer“. Heute kann U2540 als Museumsboot besichtigt werden.

German Submarine Type XXI with interior

At the beginning of 1945 with the type XXI Germany had the most advanced submarine in the world at that time. Due to numerous technical innovations it was capable of unlimited underwater travel as the diesel engines drew in the necessary fresh air through a special snorkel. It had a linear shape designed for submarine travel and its battery capacity was three times greater, giving it a sensational speed of 17 knots. Other innovations were noiseless electric motors for stealth, highly sensitive navigation instruments and 2 cm anti-aircraft gun turrets. After a short training voyage, on 04.05.1945, the U2540 was scuttled by the crew in the Flensburg Fjord. In 1957 it was raised and served in the Federal German Navy as a test vessel the "Wilhelm Bauer". Today the U2540 can be seen as a museum ship.

Beiliegenden Sicherheitstext beachten / Please note the enclosed safety advice

D: Beiliegenden Sicherheitstext beachten und nachschlagebereit halten.
GB: Please note the enclosed safety advice and keep safe for later reference.

F: Respecter les consignes de sécurité et-jointes et les conserver à portée de main.

NL: Houdt u aan de bijgaande veiligheidsinstructies en hou deze steeds bij de hand.

E: Observear y siempre tener a disposición este texto de seguridad adjunto.

I: Seguir le avvertenze di sicurezza allegate e tenere a portata di mano.

P: Ter an atzwaic a texto de segurança anexa e guardá-lo para consulto.

S: Beakta bilagade säkerhetstext och håll den i beredskap.

FIN: Noustedä ja säilyttävä ohjeet varustuksen.

DK: Overhold vedlagte sikkerhedsanvisninger og hav dem liggende i nærheden.

N: Na altid vedlagt sikkerhetstext klar til bruk.

RUS: Сохраните прилагаемый текст по технике безопасности, храните его в доступном месте.

PL: Stosować się do załączonej karty bezpieczeństwa i mieć ją stale do wglądu.

GR: Προσέχετε τις οδηγίες ασφαλείας που ακολουθεί με προσοχή τις έχετε πάντα με ελάττωχο όραση.

TR: Ekteki güvenliğin talimatlarını dikkatle okuyun, kullanışlı bir şekilde muhafaza ediniz.

CZ: Dbejte na příslušný bezpečnostní text a mějte jej připravený na dohled.

H: A melékelt biztonsági szöveget vegye figyelembe és tartsa felleopozásra készen!

SL: Priločena varnostna navodila izvajajte in jih hranite na vsem dostopnem mestu.

Dieser Bauzust wurde in mehrfachen Qualitäts- und Gewichtskontrollen auf Vollständigkeit überprüft. Bei Reklamationen wenden Sie sich bitte grundsätzlich an Ihren Fachhändler; bitte halten Sie hierzu die **Bausanleitung**, das aus der Kartongabe ausgeschlittene **EAN-Strichcode-Feld** sowie den **Kassenbon**.

This Model Kit has been subject to extensive quality and weight checks during the manufacturing process to ensure it leaves our warehouse in perfect condition. If there are any problems with the product please contact your supplying dealer directly. Please ensure that you have retained the original receipt, instruction sheet and barcode.

Forma hergestellt und im Eigentum von Revell GmbH & Co. KG. Wiedereinfache Nachbildungen werden gerichtlich verfolgt.

Forma produsida e in proprietate de Revell GmbH & Co. KG. Toate reprodusurile ulterioare fara autorizatie sunt interzise.

Modello fatto e in proprietà di Revell GmbH & Co. KG. Qualsiasi riproduzione senza permesso è vietata.

Forma produsida della Revell GmbH & Co. KG. e di proprietà della stessa impresa, le quale qualsiasi riproduzione senza ogni autorizzazione è vietata.

Modell av Revell GmbH & Co. KG. utvirket og i eiebesittelse av Revell GmbH & Co. KG. Utsvirket og i eiebesittelse av andre personer er forbudt.

Forma e produsida og este in Revell GmbH & Co. KG. Drepturile rezervate sunt protejate prin lege.

Modell av Revell GmbH & Co. KG. utvirket og i eiebesittelse av Revell GmbH & Co. KG. Utsvirket og i eiebesittelse av andre personer er forbudt.

Forma e produsida e in Revell GmbH & Co. KG. Drepturile rezervate sunt protejate prin lege.

Forma e produsida e in Revell GmbH & Co. KG. Drepturile rezervate sunt protejate prin lege.

(Délai de traitement: 6 semaines), en joignant à votre courrier la notice de montage. Le cc EAN découpe sur la boîte, ainsi que votre ticket de caisse. Aucune demande ne sera prise en compte sans ces trois éléments. Aucune demande ne sera traitée par téléphone depuis notre bureau de Dijon.

Deze bouwdoos werd verscheidene malen volledig gecontroleerd op kwaliteit en gewicht. Bij klachten wendt u zich hoofdzakelijk tot uw winkelier; u wordt verzocht dan bouwhandleiding, de uit de doos geknipte EAN-streepcode alsmede de kassabon met u nemen.

Modell manufactured by and property of Revell GmbH & Co. KG. Illegal imitations are subject to prosecution.

Forma produsida e in proprietate de Revell GmbH & Co. KG. Toate reprodusurile ulterioare fara autorizatie sunt interzise.

Modello fatto e in proprietà di Revell GmbH & Co. KG. Qualsiasi riproduzione senza permesso è vietata.

Forma produsida della Revell GmbH & Co. KG. e di proprietà della stessa impresa, le quale qualsiasi riproduzione senza ogni autorizzazione è vietata.

Modell av Revell GmbH & Co. KG. utvirket og i eiebesittelse av Revell GmbH & Co. KG. Utsvirket og i eiebesittelse av andre personer er forbudt.

Forma e produsida og este in Revell GmbH & Co. KG. Drepturile rezervate sunt protejate prin lege.

Forma e produsida e in Revell GmbH & Co. KG. Drepturile rezervate sunt protejate prin lege.

Forma e produsida e in Revell GmbH & Co. KG. Drepturile rezervate sunt protejate prin lege.

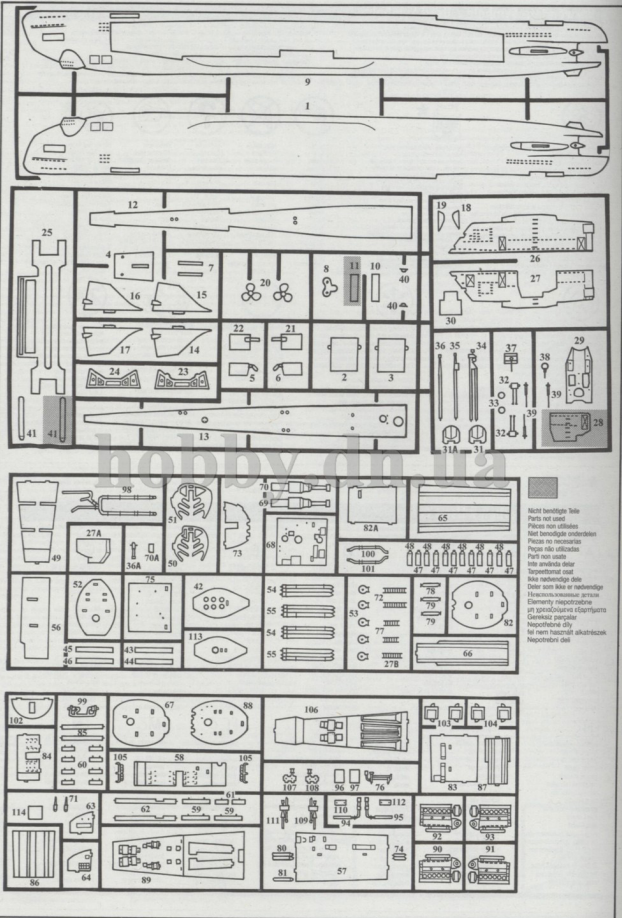

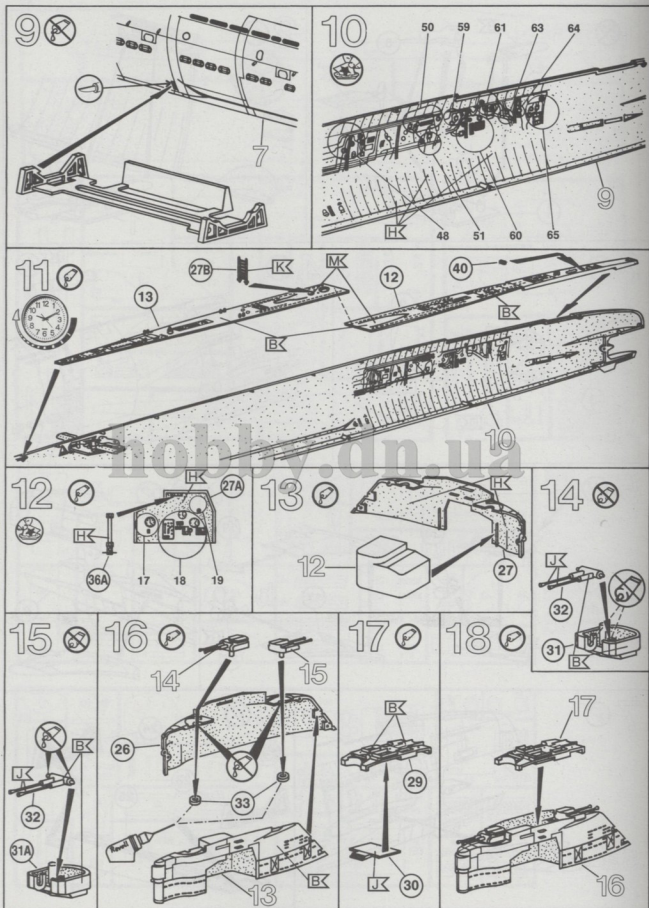

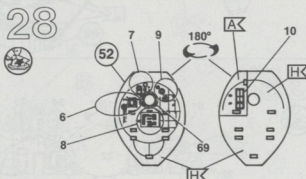
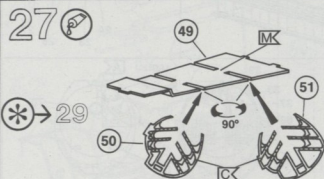
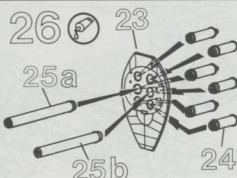
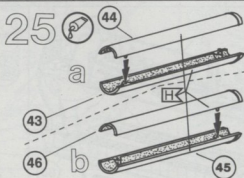
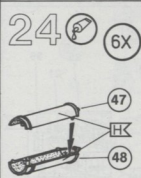
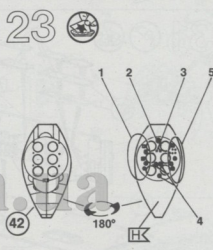
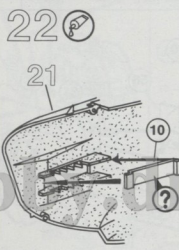
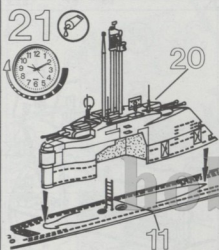
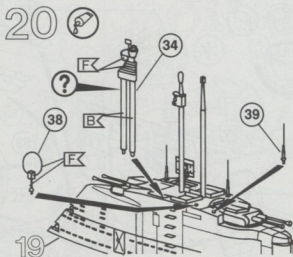
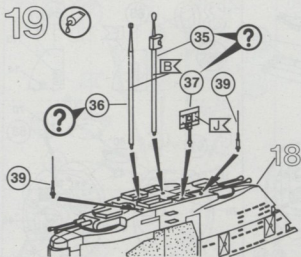

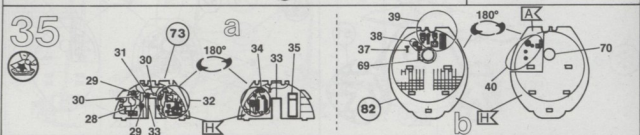
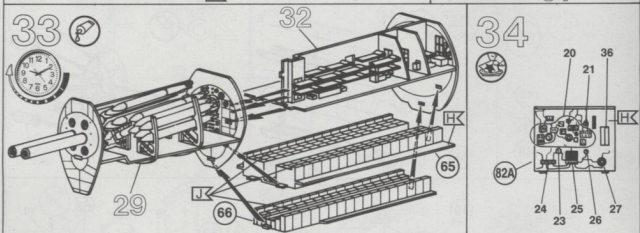
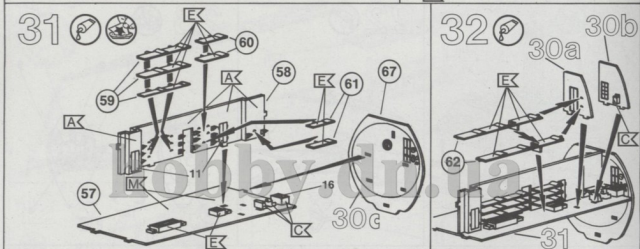
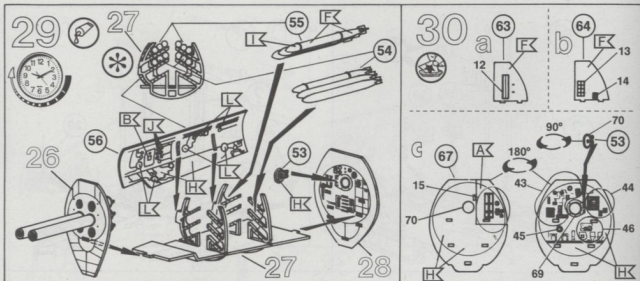

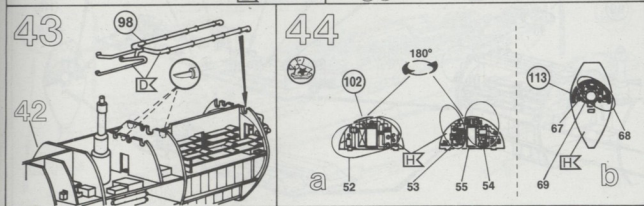
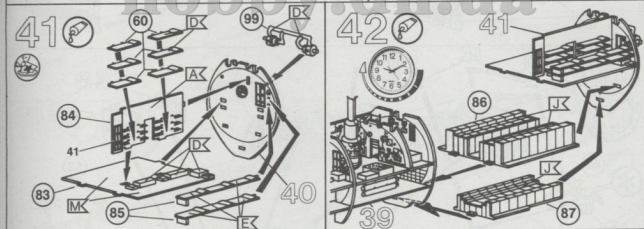
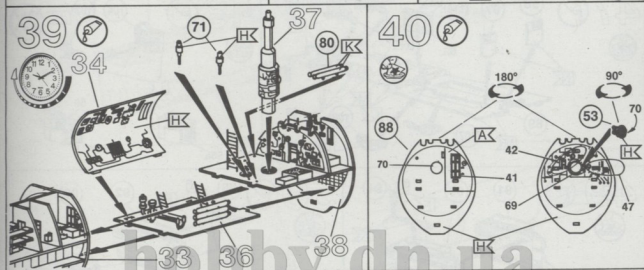
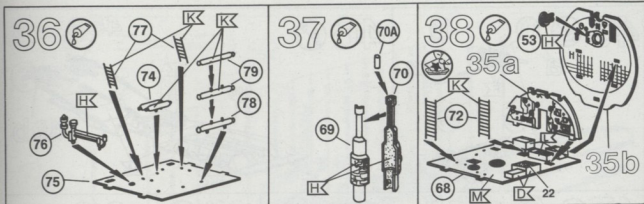

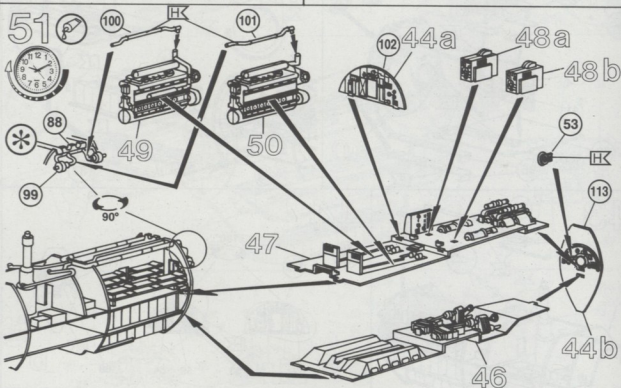
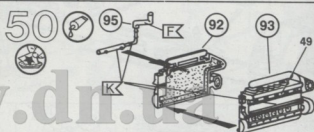
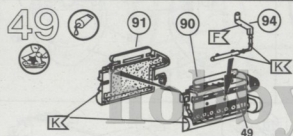
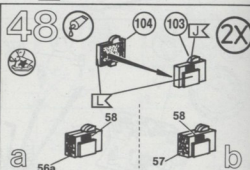
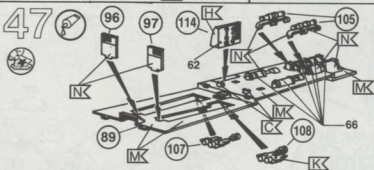
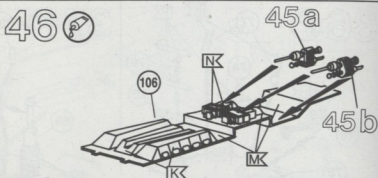
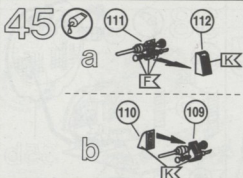

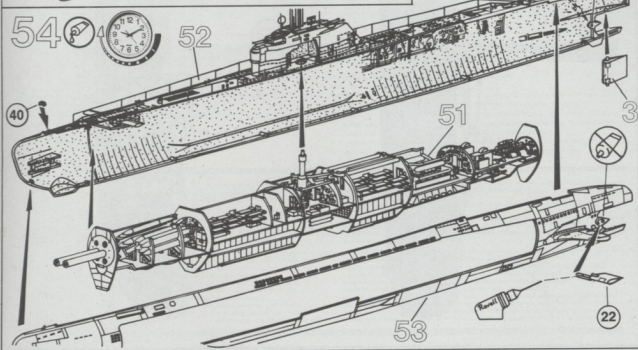
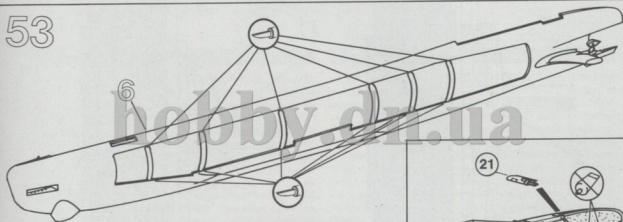
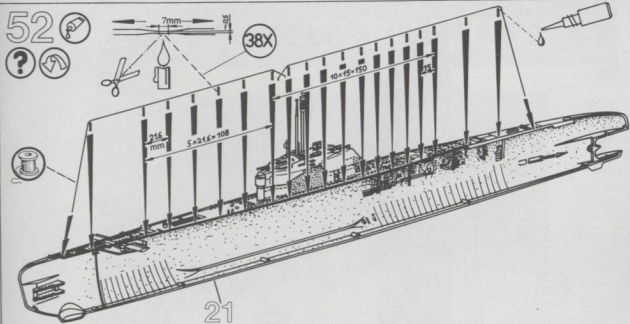

55



U-2540

