

LIMITED EDITION

SOVA-M
SVM-72021

KDA-2
Type 88-I

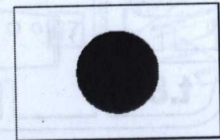

UNASSEMBLED PLASTIC MODEL KITS

SCALE: 1/72

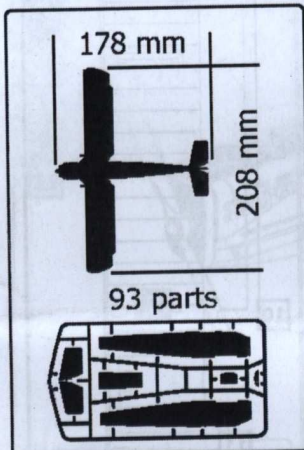

DECALS

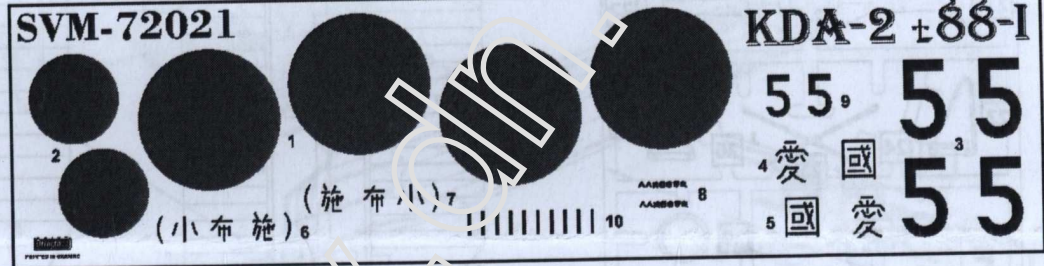

ONE VERSION OF COLOURING

The Army KDA-2 Type 88 Reconnaissance Aircraft was designed for Kawasaki in 1927. After flight testing, the aircraft was accepted and ordered into production as the Army Type 88-I Reconnaissance Biplane. At the beginning of 1929 a new version of the aircraft the Type 88-II was designed and put into production. Between 1929 and 1932, a bomber version was built as the Type 88 Light Bomber, differed with a strengthened lower wing and an additional pair of centre-section struts. Both reconnaissance and bomber versions participated in combat of the Imperial Japanese Army Air Force during the Second Sino-Japanese War until 1940.

The model is executed on technology short run and is intended only for experienced modelers.

Word-wide distributor for Sova-M kits:
ModelSvit Balkans Ltd. 4003 Plovdiv,
Bulgaria 9, zk Maritza Gardens.
Tel. +359 32 397 069,
E-Mail: modelsvitbalkans@gmail.com
MADE IN UKRAINE

PAINTS

- | | |
|-------------------------------------|-------------------------------|
| A HUMBROL 147 LIGHT GREY | B HUMBROL 33 BLACK |
| C HUMBROL 53 GUNMETAL | D HUMBROL 27003 STEEL |
| E HUMBROL 110 WOOD | F HUMBROL 113 RUST |
| G HUMBROL 158 INTERIOR GREEN | H HUMBROL 56 ALUMINIUM |
| J HUMBROL 62 LEATHER | |

SYMBOLS

- | | | |
|----------------------------------|-------------------|---------------|
| 1 STAGES OF ASSEMBLY | TO PAINT | TO BEND |
| 1 NUMBER PARTS | GLUE | SCRATCH BUILT |
| APPLY DECALS | DON'T GLUE | OPEN HOLE |
| x2 QUANTITY OF OPERATIONS | НА ВИБІР OPTIONAL | CAT OUT |

SET OF THE PARTS

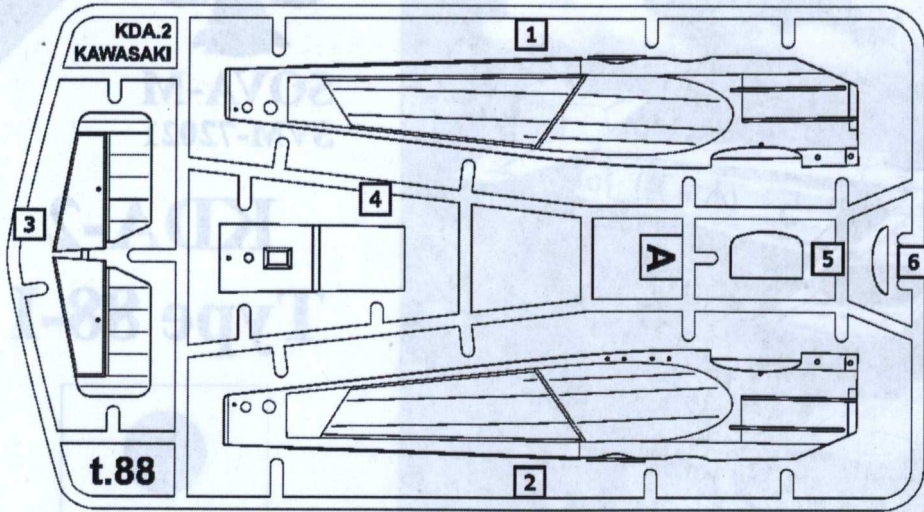

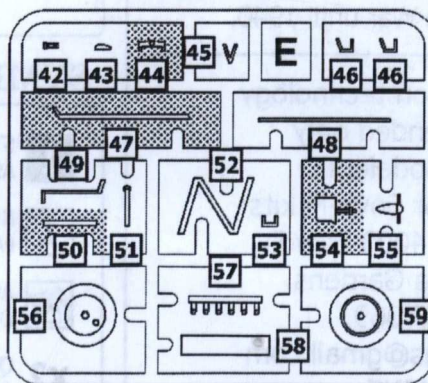
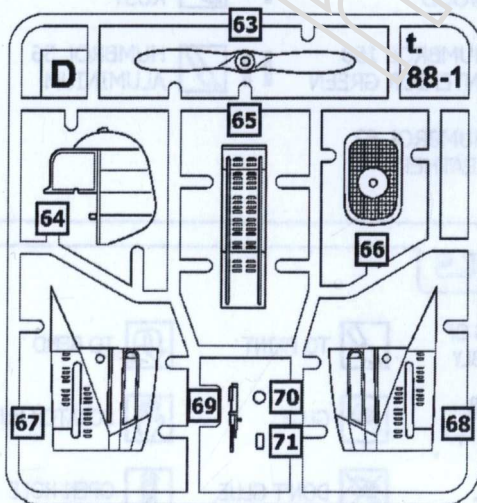
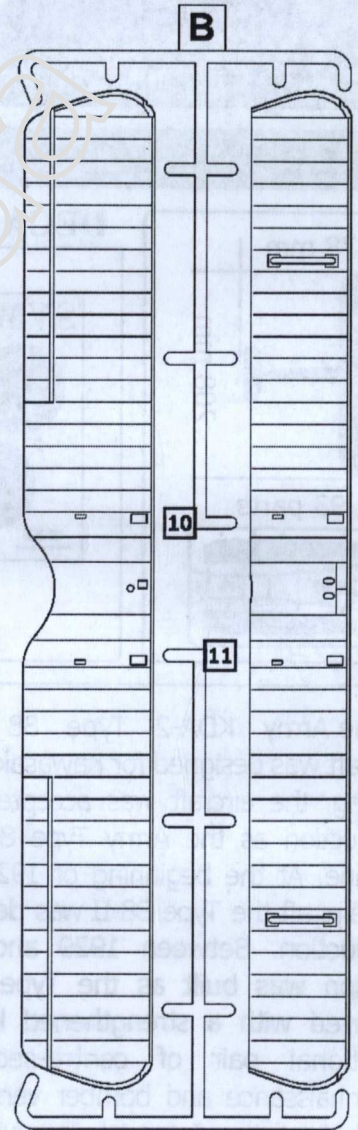
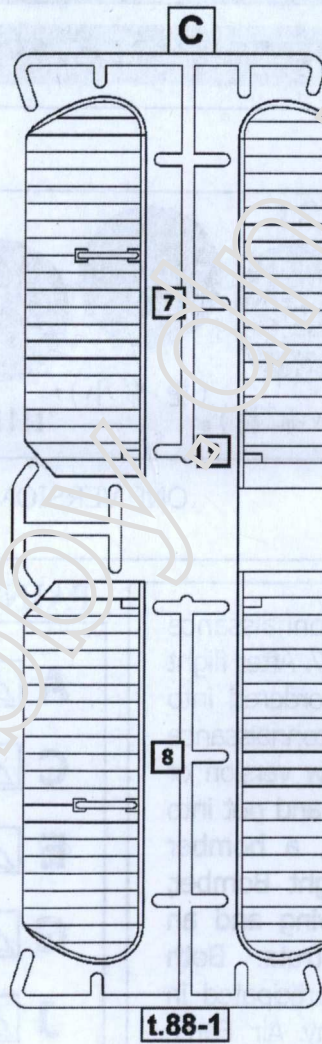
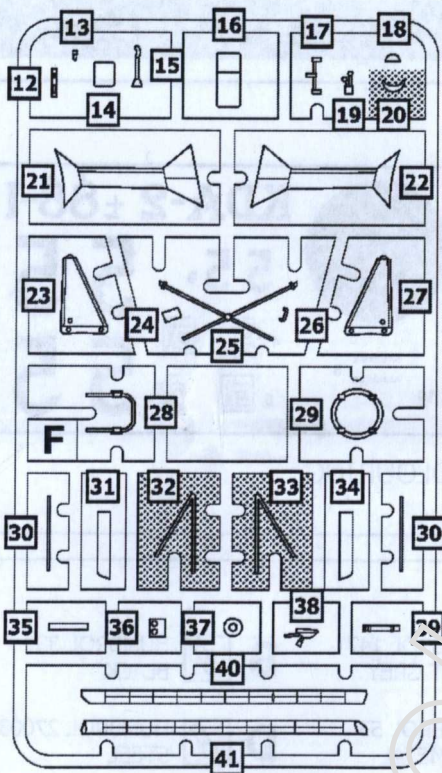

PARTS NOT FOR USE

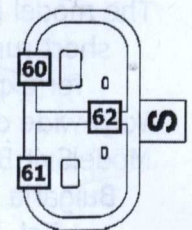

x2

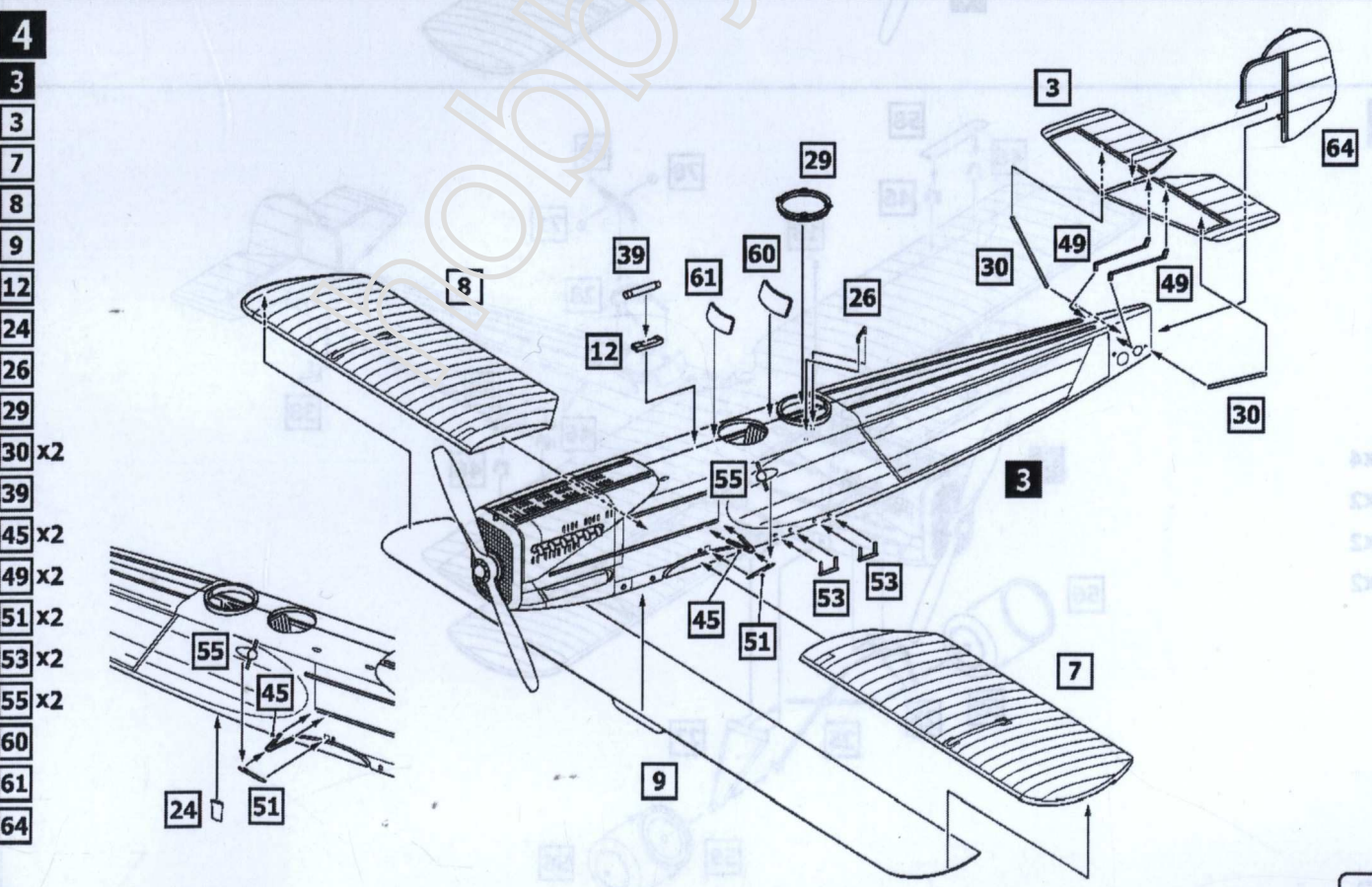
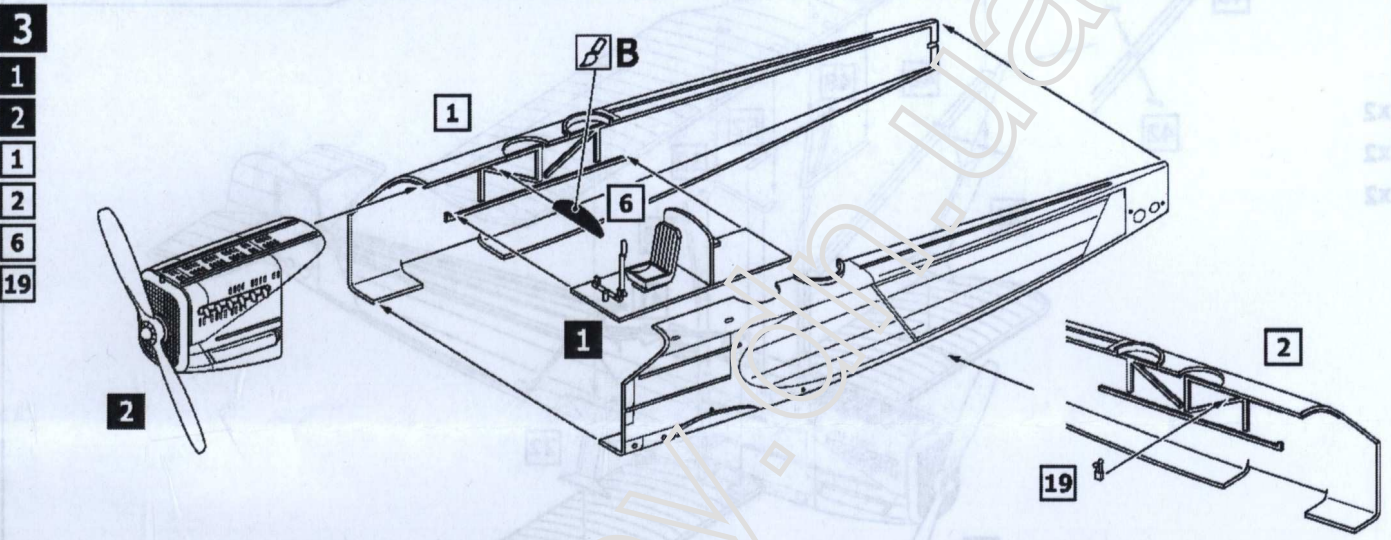
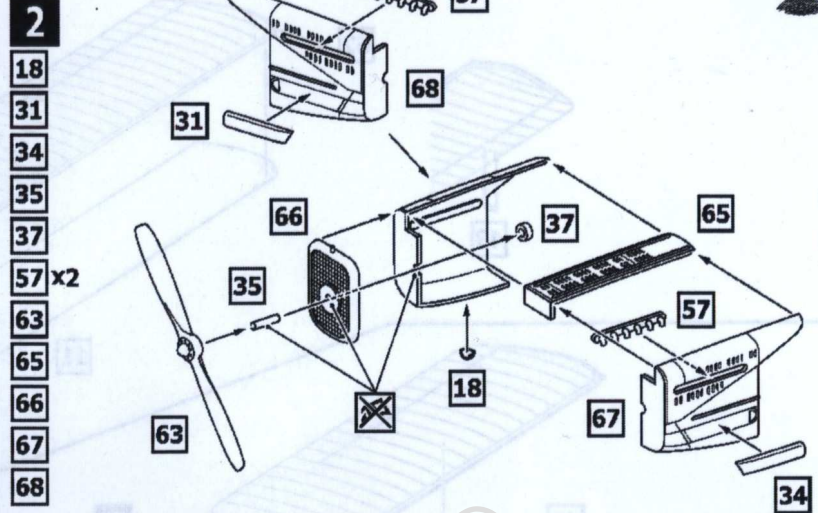
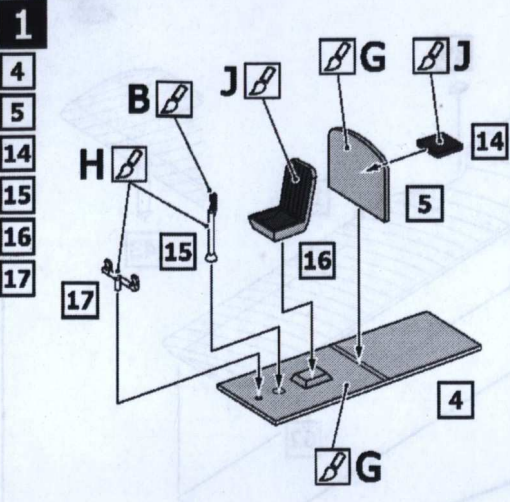

ASSEMBLY INSTRUCTION



ASSEMBLY INSTRUCTION



- 5**
- 10**
- 11**
- 36**
- 43** x2
- 62** x2

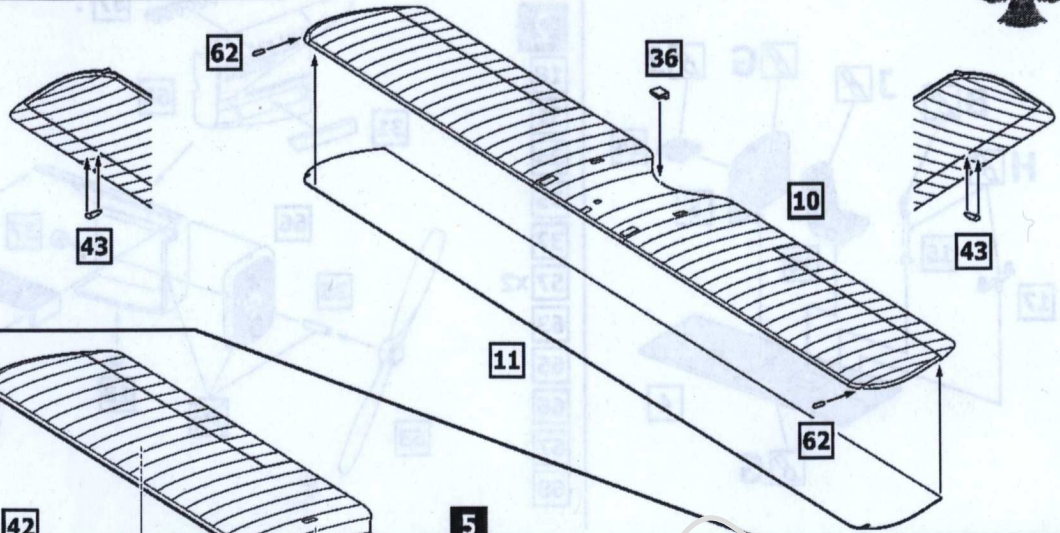

- 6**
- 4**
- 5**
- 21**
- 22**
- 40**
- 41**
- 42** x2
- 48** x2
- 52** x2

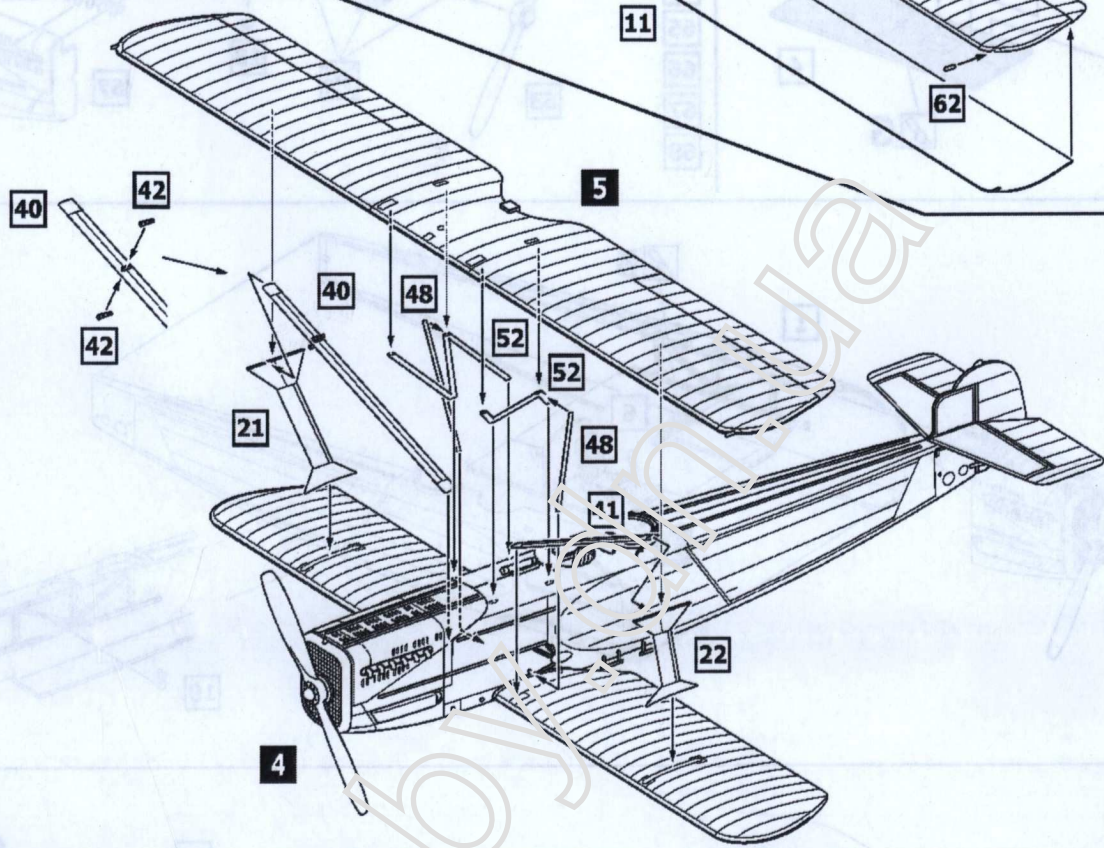

- 7**
- 6**
- 13**
- 23**
- 25**
- 27**
- 28**
- 38**
- 46** x4
- 56** x2
- 58** x2
- 59** x2
- 69**
- 70**
- 71**

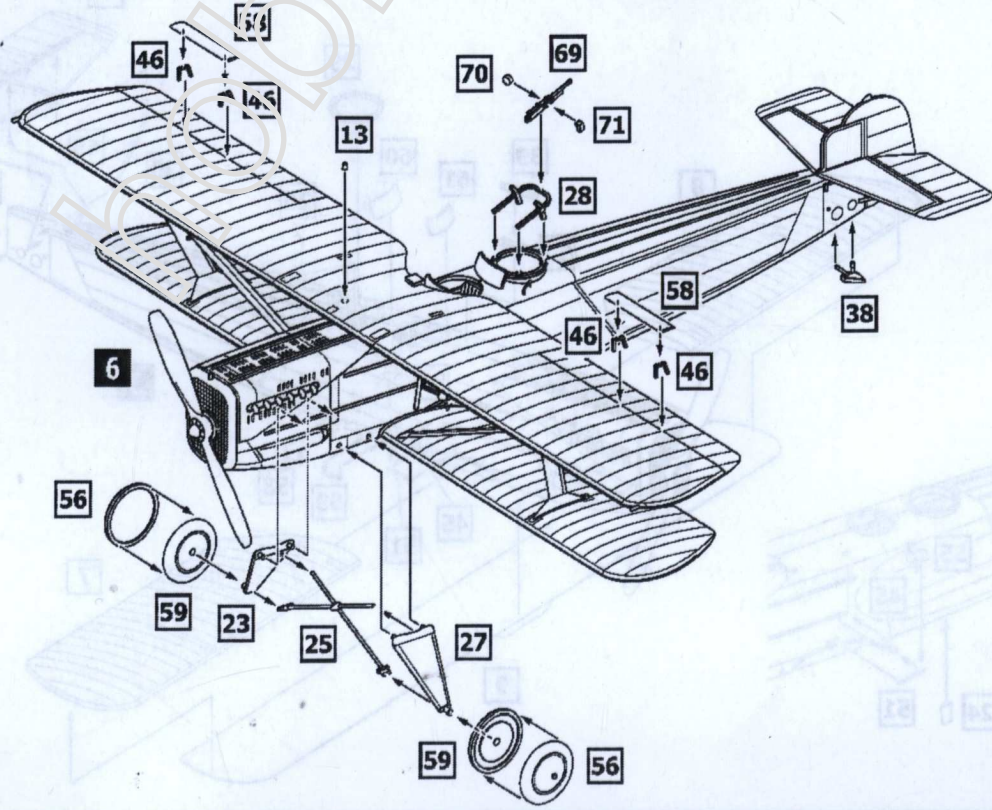

MARKING & PAINTING

Kawasaki KDA-2 Type 88-I

