

Sd.Kfz 250/1 Ausf.A (Alte Ausführung)

1/72

CZ

Sd.Kfz 250 byl vyvinut na základě požadavků Wehrmachtu na rozvoj výstavby jednotek polopásových transportérů. Během plánování požadavků na jednotlivé kategorie polopásových transportérů vyvstala potřeba menšího a levnějšího vozidla, než byl standardní polopás Sd.Kfz 251. V rámci urychlení vývoje byla použita podvozková skupina neparceňovanáho vozidla Demag D7 (Sd.Kfz 10). Pro tu byla firmou Büssing zkonstruována pancéřová nástavba. Ta byla svařována z pancéřových desek navazujícími na sebe pod značnými úhly. Tím byla zvýšena odolnost proti odstřelování. Nástavba měla šestiúhelníkový tvar. První prototyp byl postaven v roce 1939. Následovaly ho další prototypy, intenzivně testované. Náročnými testy ověřené stroje se začaly sériově vyrábět v roce 1941. Podobně jako u Sd.Kfz 10 byl původně montovaný motor Maybach HL 38 u sériových Sd.Kfz 250 nahrazen spolehlivějším HL 42 se stejným výkonem. Do konce roku 1941 Wehrmacht dostal 39 kusů, velkosériová produkce provedení Sd.Kfz 250 později nazvaného Alte Ausführung běžela celý rok 1942 a část roku 1943. V roce 1943 se začala vyrábět provedení Sd.Kfz 250 Neue Ausführung. Tvar pancéřové vany byl změněn na výrobně jednodušší obdélníkový. Výroba běžela až do konce roku 1944, kdy byla zastavena. Celkově bylo vyrobeno skoro 6000 těchto výborných strojů v mnoha variantách. Důvodem zastavení výroby byla celková krize produkce německých továren a snaha po zjednodušení a zlevnění výroby. Standardním polopásovým vozidlem Wehrmachtu měl být větší Sd.Kfz 251. K náhradě ale nedošlo. Sd.Kfz 250 bojovaly v první linii až konce druhé světové války. Nasazeny byly na východní i západní frontě a část strojů bojovala i v Africe. Po válce byly krátce používány v několika armádách, včetně československé. Podobně jako jiné bojové stroje Wehrmachtu byl Sd.Kfz 250 obou provedení dodáván v mnoha variantách. Ty označovalo lomítka a číslice za ním. Sd.Kfz 250/1 byl standardní transportér pěchoty pro polovinu družstva. Sd.Kfz 250/2 sloužil ke kladení linek polního telefonu, Sd.Kfz 250/3 bylo velitelské vozidlo s různými typy radiovybavení. Varianty Sd.Kfz 250/4 a /5 sloužily k průzkumu, Sd.Kfz 250/6 sloužil jako transportér munice pro samohybná děla Stug III. Jako pohyblivý minomet sloužila varianta Sd.Kfz 250/7. Sd.Kfz 250/8, /9, /10 a /11 byly vybaveny různými typy protitankových zbraní. Poslední oficiální variantou se stala verze Sd.Kfz 250/12, sloužící jako mobilní stanoviště řízení palby. Další výzbrojní varianty vznikly na frontě či v opravárenských jednotkách iniciativou vojáků. Základní Sd.Kfz 250 posloužil k vývoji typů Sd.Kfz 252 a Sd.Kfz 253. Sd.Kfz 252 bylo speciální vozidlo pro dopravu munice v oblasti bojů. Sd.Kfz 253 pak průzkumné vozidlo pro spolupráci se svazky tankových jednotek nebo jednotek útočných děl. Vzhledově odpovídalo Sd.Kfz 250, ale prostor osádky, u Sd.Kfz 250 otevřený, byl u Sd.Kfz 253 uzavřen pancéřovou deskou s dvěma průlezy.

EN

The Sd.Kfz 250 half track vehicle was developed to the Wehrmacht requirements calling for growing development of half track transporter units. While planning the respective categories of the half track vehicles, the need arose for a vehicle smaller and cheaper than was the Sd.Kfz 251, by then already in standard service. To speed up the development of such a vehicle, a chassis the unarmoured Demag D7 (Sd.Kfz 10) halftrack was used and a new, armoured body constructed by Büssing company. This hull armour plates were welded in rather considerable angles, giving the vehicle a degree of safety from enemy fire. The hull was of a hexagonal shape. The prototype vehicle was built in 1939, soon to be followed by a few more ones, all of which were put to rather demanding tests. The mass production of the test-proven design commenced in 1941. At first, the vehicles were powered by a Maybach HL 38 engine which in production Sd.Kfz 250 vehicles was later replaced by a HL 42 type of the same power, in a manner similar to the Sd.Kfz 10. By the end of 1941, the Wehrmacht received 39 vehicles. The mass production of the early type later called Alte Ausführung ran for the whole next year and for a couple of months of 1943, when the version was replaced by a newer one known as the Sd.Kfz 250 Neue Ausführung. Its hull was of a simplified, rectangular shape, easier to produce. The production lasted until the end of 1944 when it was stopped. In total, almost 6000 of these excellent vehicles were produced in many variants. The reason for halting the production was partly the crisis of the production from German factories, partly because of the effort to make the production less demanding and less expensive – the larger Sd.Kfz was expected to become the standard halftrack transport vehicle of the Wehrmacht. The replacement did not realize in the end, though. The Sd.Kfz 250 fought in the front line service until the end of the war. They were used on both the Eastern and Western fronts, some of the machines found themselves also in Africa. In the post war period, they served with armies of some other countries as well, including that of Czechoslovakia. As well as other Wehrmacht vehicles, both versions of the Sd.Kfz 250 were delivered in many varieties, designated by a numeral behind the slash. The Sd.Kfz 250/1 was a standard troop carrier able to carry half a squad. The Sd.Kfz 250/2 was equipped with a cable-laying gear, the Sd.Kfz 250/3 was a command radio vehicle. Both the Sd.Kfz 250/4 and 250/5 were reconnaissance vehicles with various types of radio equipment. The 250/6 variant was an ammunition transporter for the Stug III assault gun. The 250/7 carried an 81mm mortar and variants 250/8 to 250/11 were equipped with various sorts of anti-tank armament. The final, officially recognized variant was the Sd.Kfz 250/12 fitted for range spotting and fire control. Further variants were also created, both at the front and in rear line repair units, by the initiative of military personnel. The basic Sd.Kfz 250 type gave rise to the development of the Sd.Kfz 252 and 253, the former of which was a specialized, ammunition carrying vehicle operating on battlefield, the latter was a reconnaissance vehicle cooperating with tank or assault gun units. In overall appearance it was similar to the Sd.Kfz 250 but its hull was enclosed by a armour plate with two manholes, while the body of the Sd.Kfz 250 was open on the top.

Plastic Parts

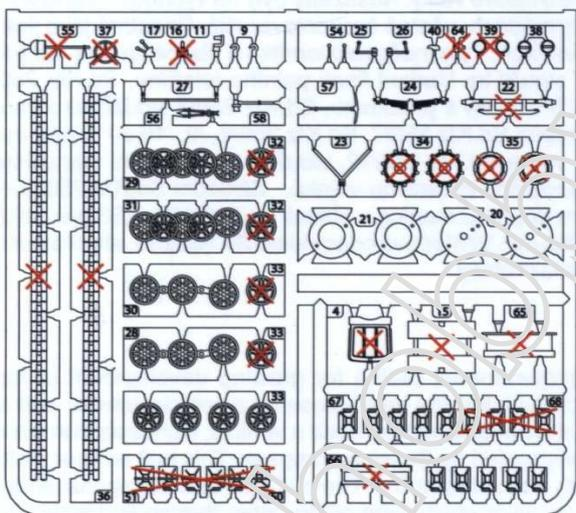
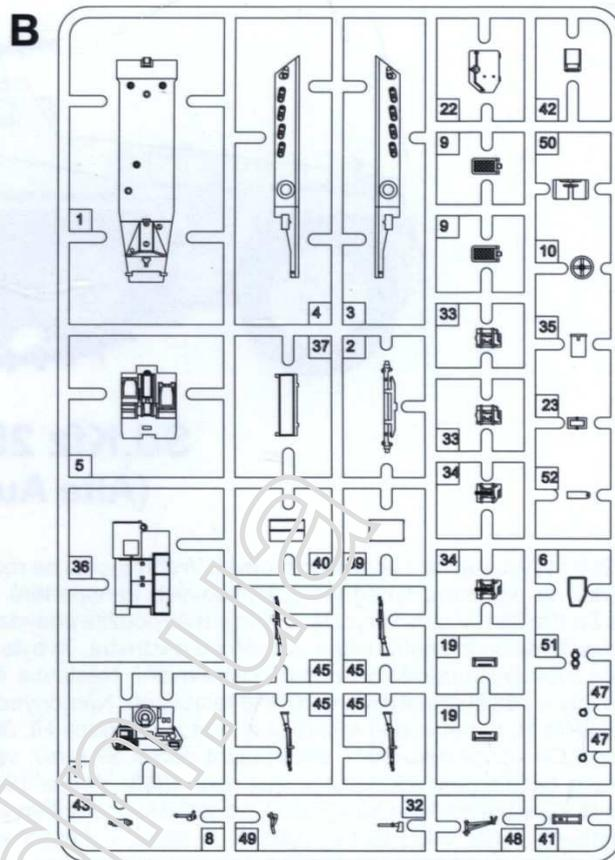
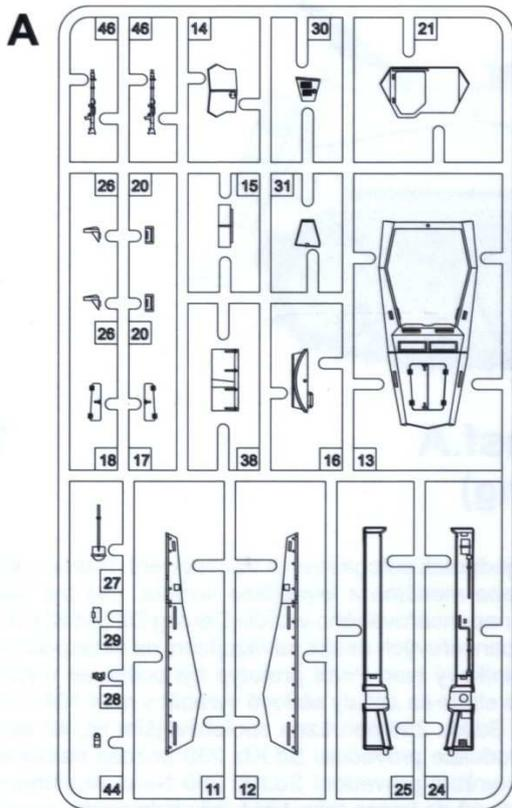

C

Photo-Etched Parts (PP)

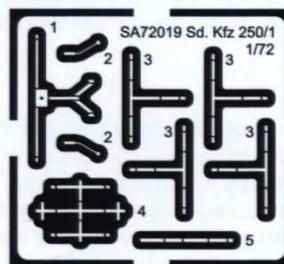

D

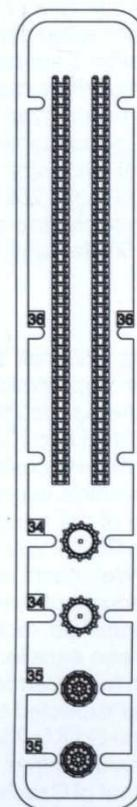

Barvy GUNZE/ GUNZE Colour No.

Barva pneu / Tyre Black	H77 / C137
Špinavě bílá / Off White	H21 / C69
Polní šedá Panzergrau / Field Grey	H32 / C40
Tmavá žlutá / Dark Yellow RAL 7028	H79 / C39
Žluto hnědá / Yellow Brown RAL 8000	H32 / C40
Ocelová / Steel	H18 / C28

SYMBOLS



MOŽNOST VOLBY
OPTIONAL
NACH BELIEBEN
OPTION



POUŽÍT KYANOAKRYLÁTOVÉ LEPIDLO
INSTANT CYANOACRYLATE GLUE
ZYANOAKRYLATKLEBER
COLLE CYANOACRYLAT



OHNOUT
BEND
BIEGEN
COURBER



ZHOTOVIT NOVÉ
SCRATCH BUILD
FERTIGSTELLEN
ACHEVER



ŘEZAT/VRTAT
CUT OFF/DRILL
ENTFERNEN
DETACHER



GSI
colour code

NATRÍT
COLOUR
FARBEN
PEINDRE

STEP 1

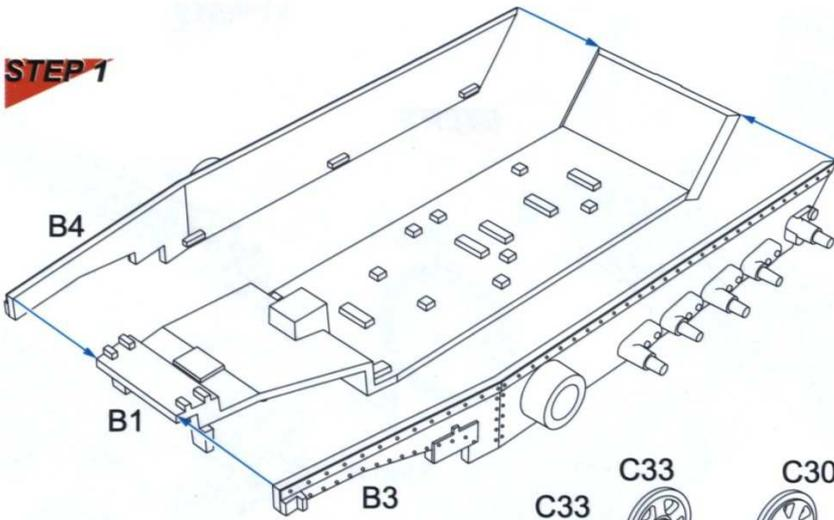

STEP 2 2x

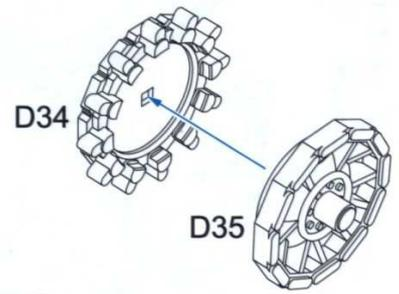

STEP 3

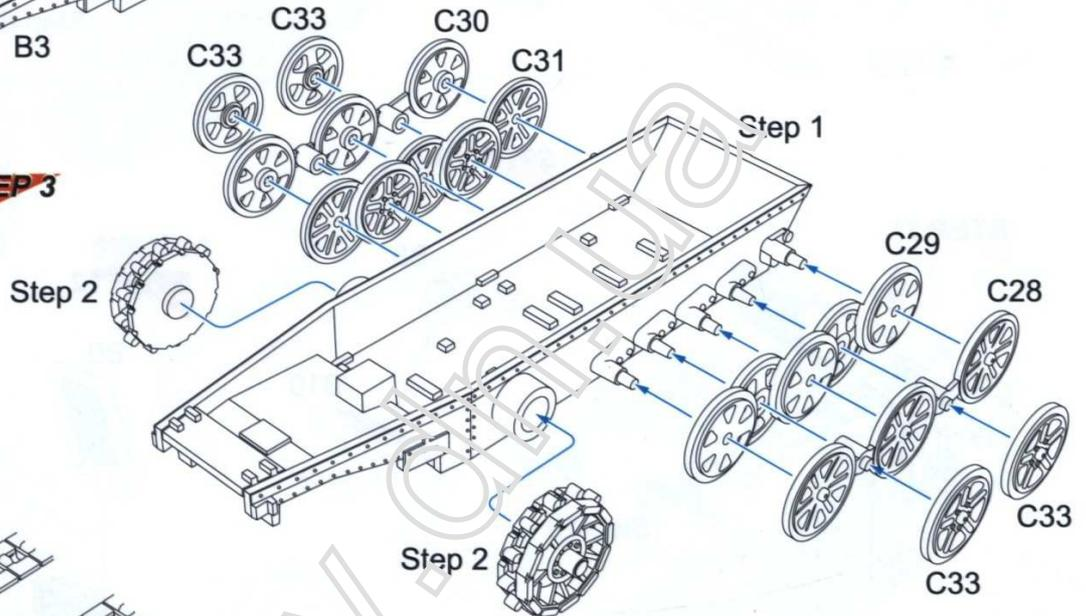

STEP 4

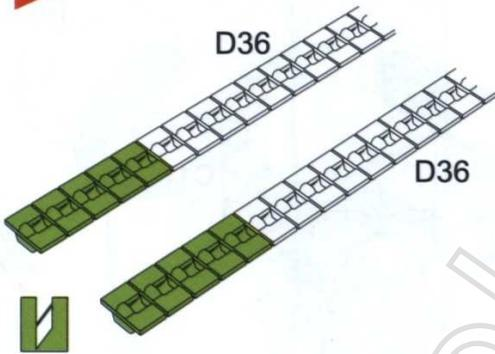

STEP 5

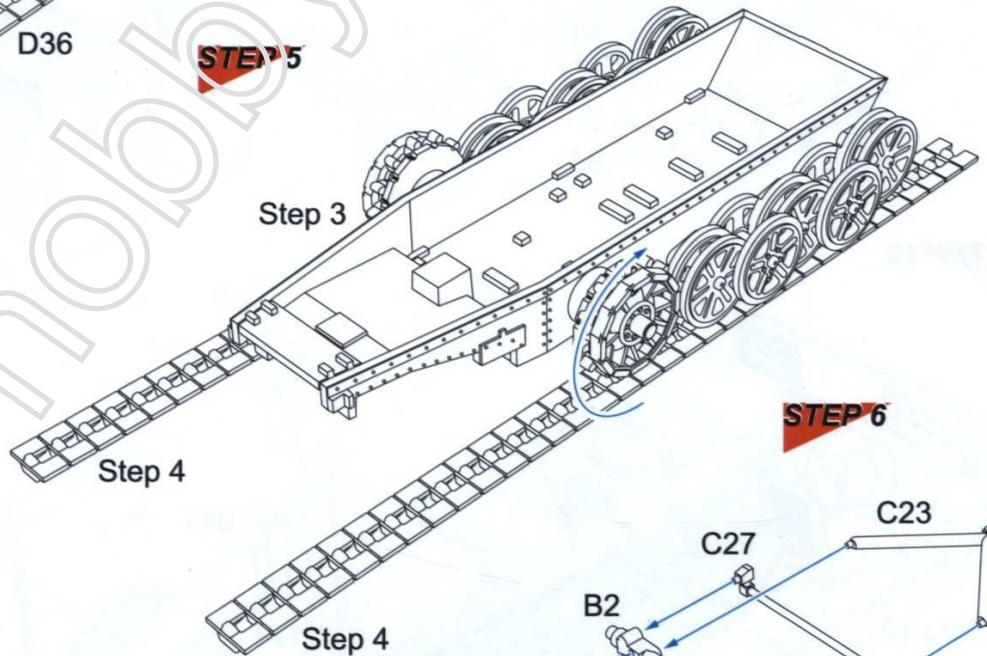

STEP 6

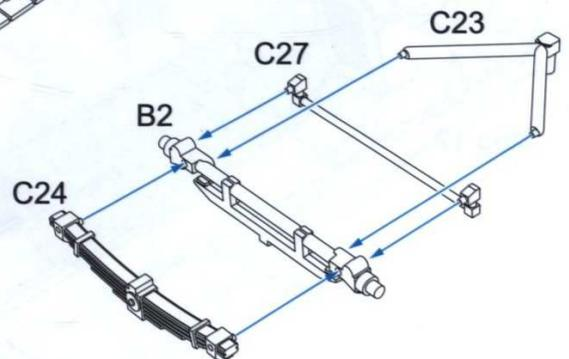

STEP 7 2x

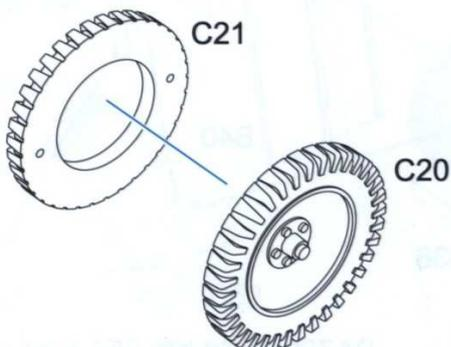

STEP 8

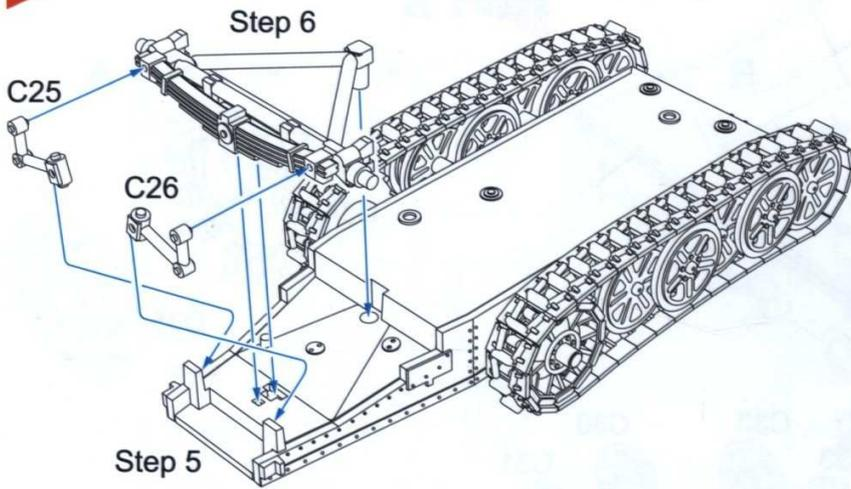

STEP 9

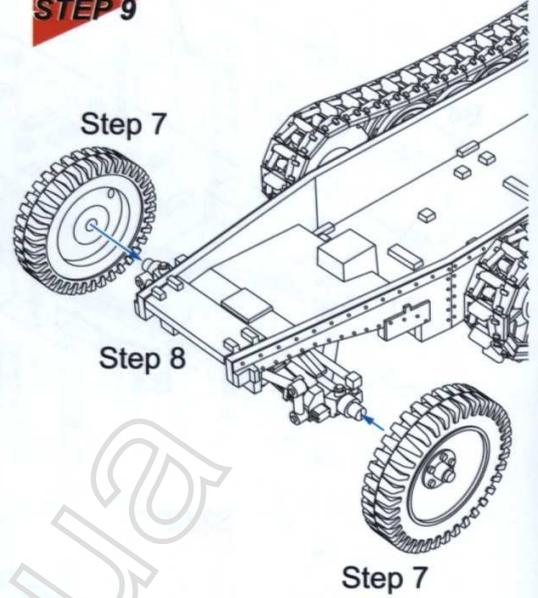

STEP 11

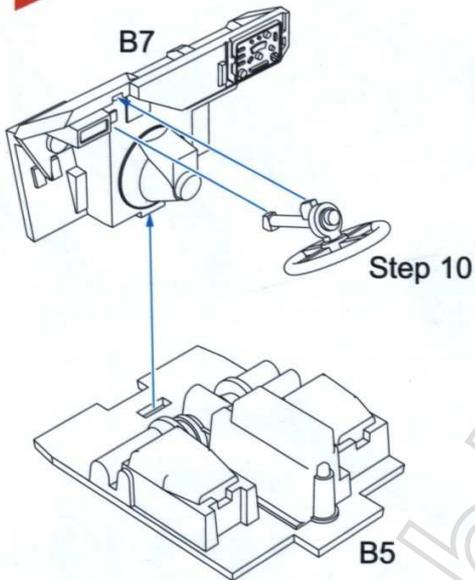

STEP 10

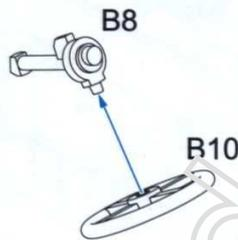

STEP 12

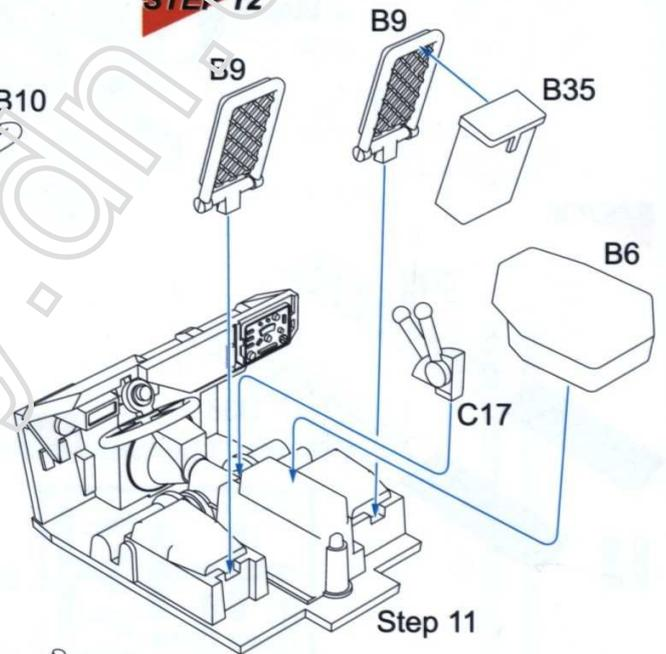

STEP 13

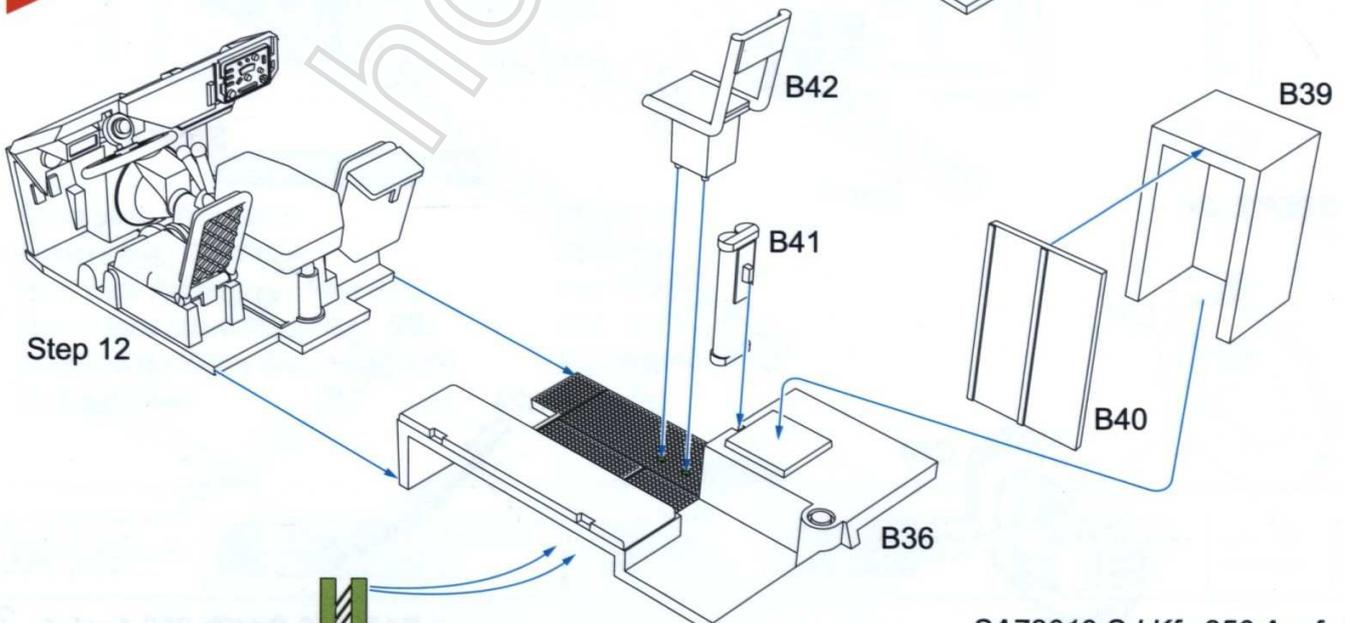

STEP 14

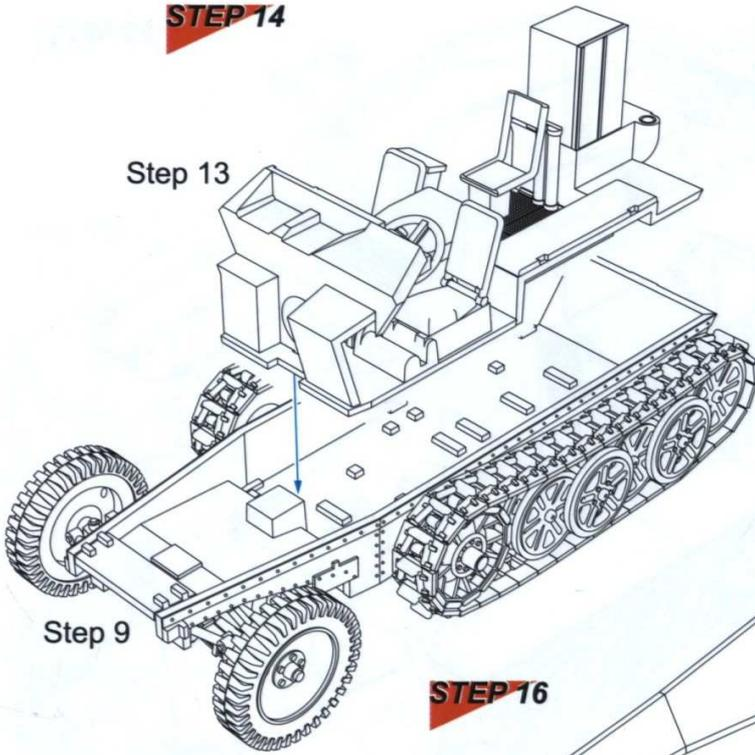

STEP 15

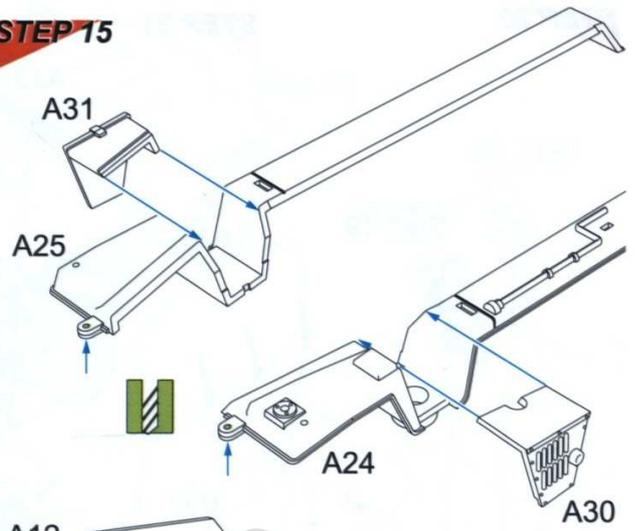

STEP 16

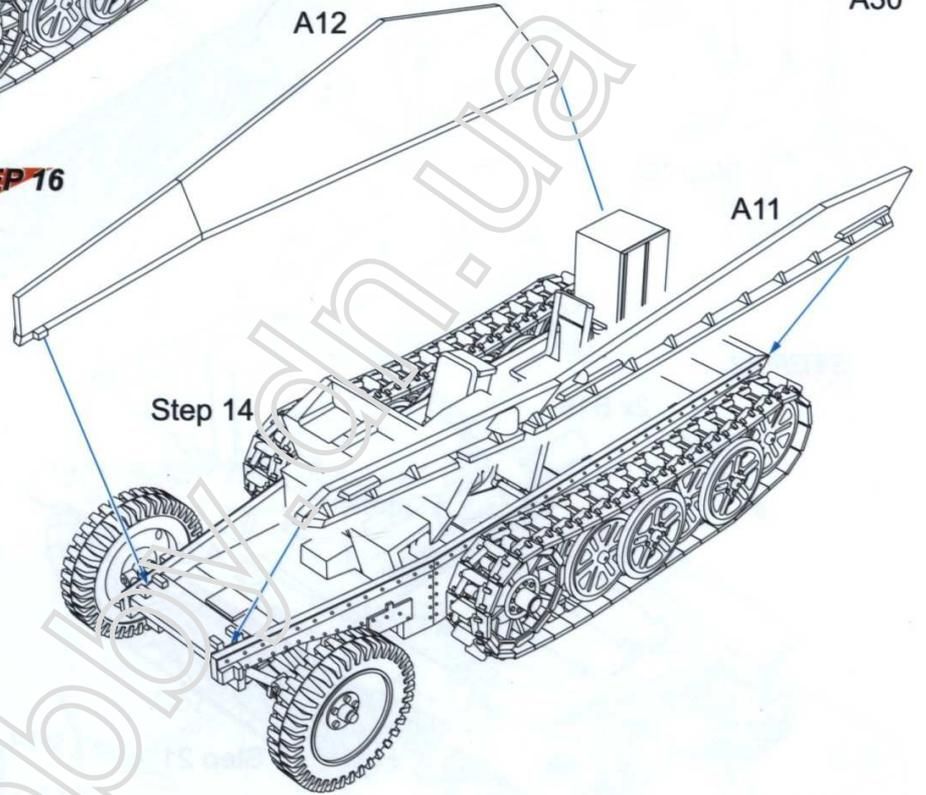

STEP 17

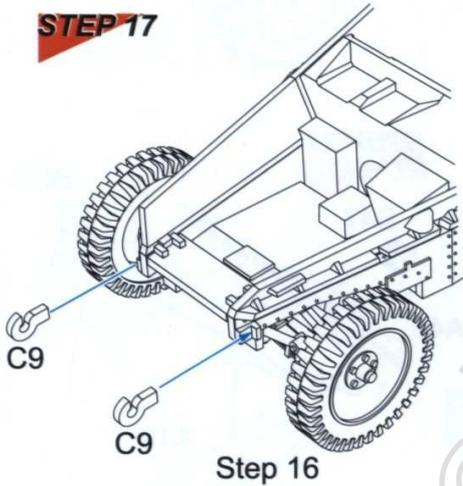

STEP 18

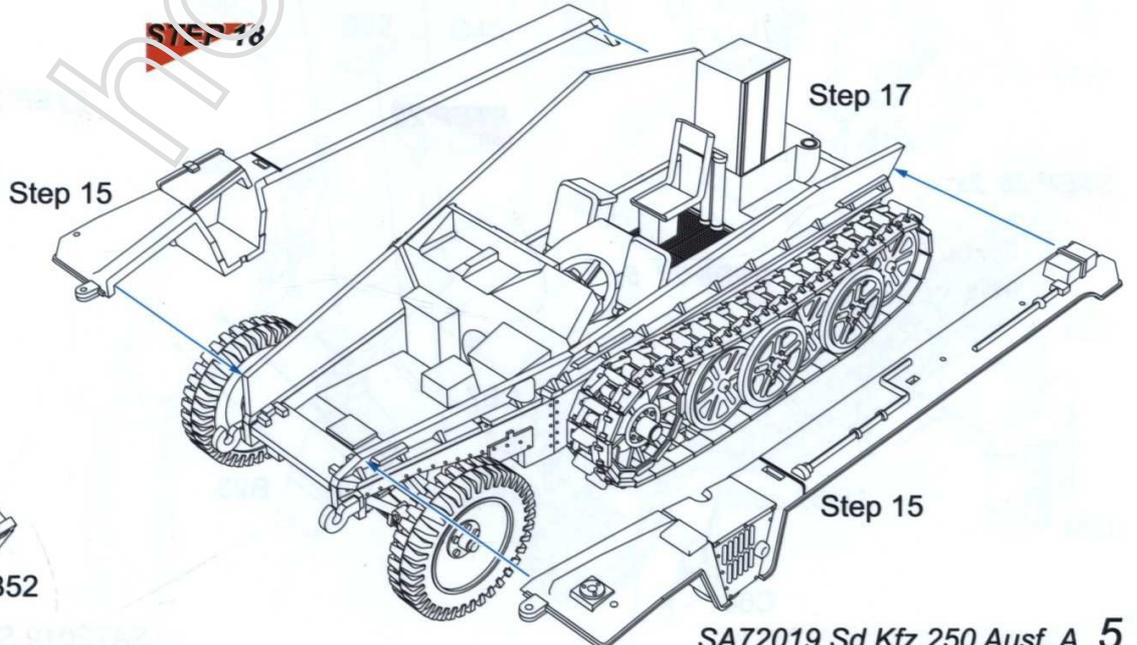

STEP 19

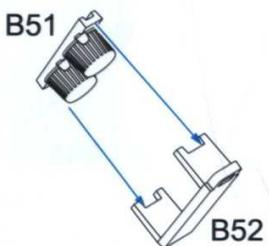

STEP 20

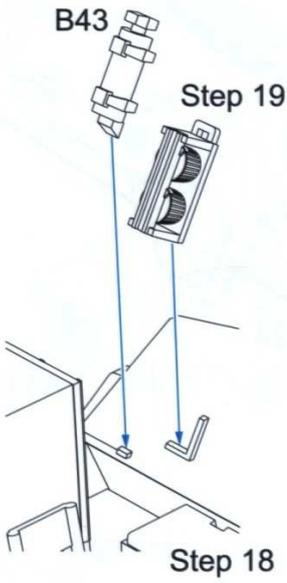

STEP 21

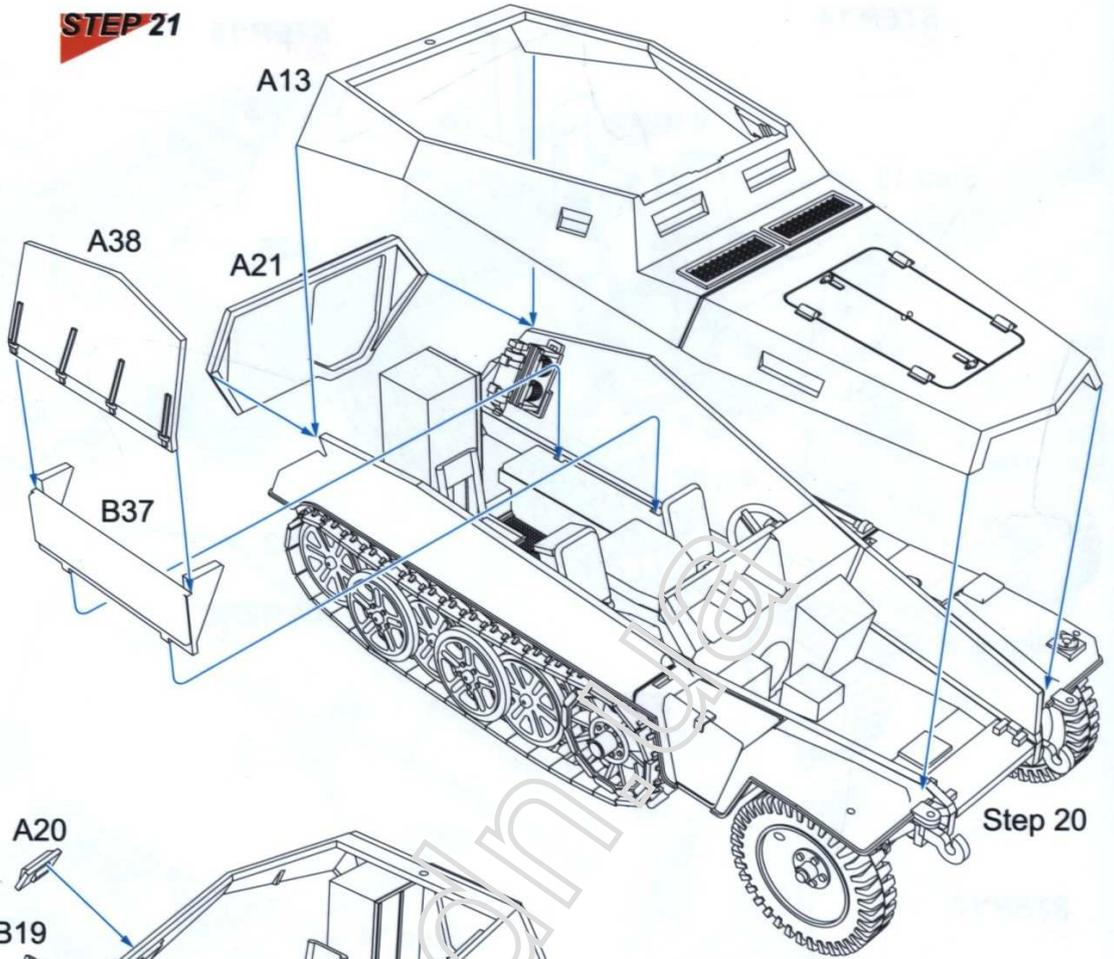

STEP 22

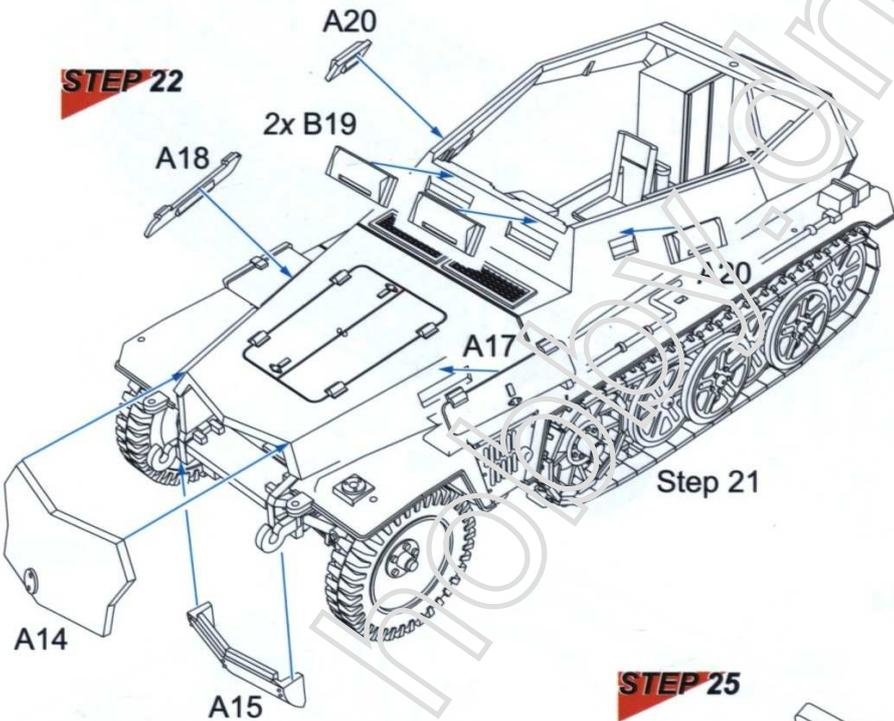

STEP 23

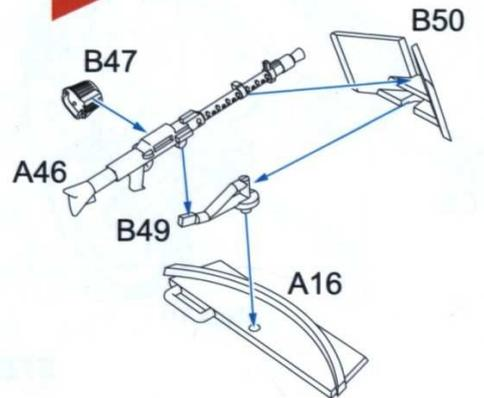

STEP 24

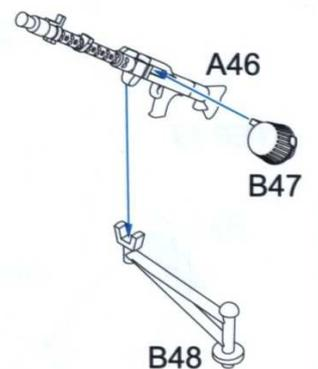

STEP 25

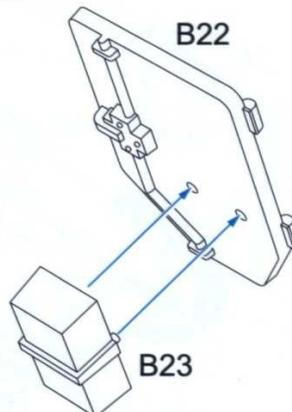

STEP 26 2x



STEP 27 5x

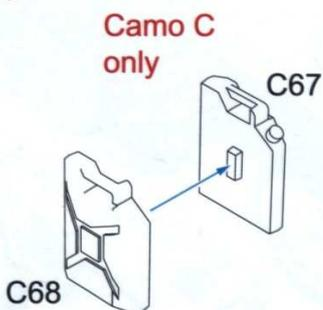

STEP 28

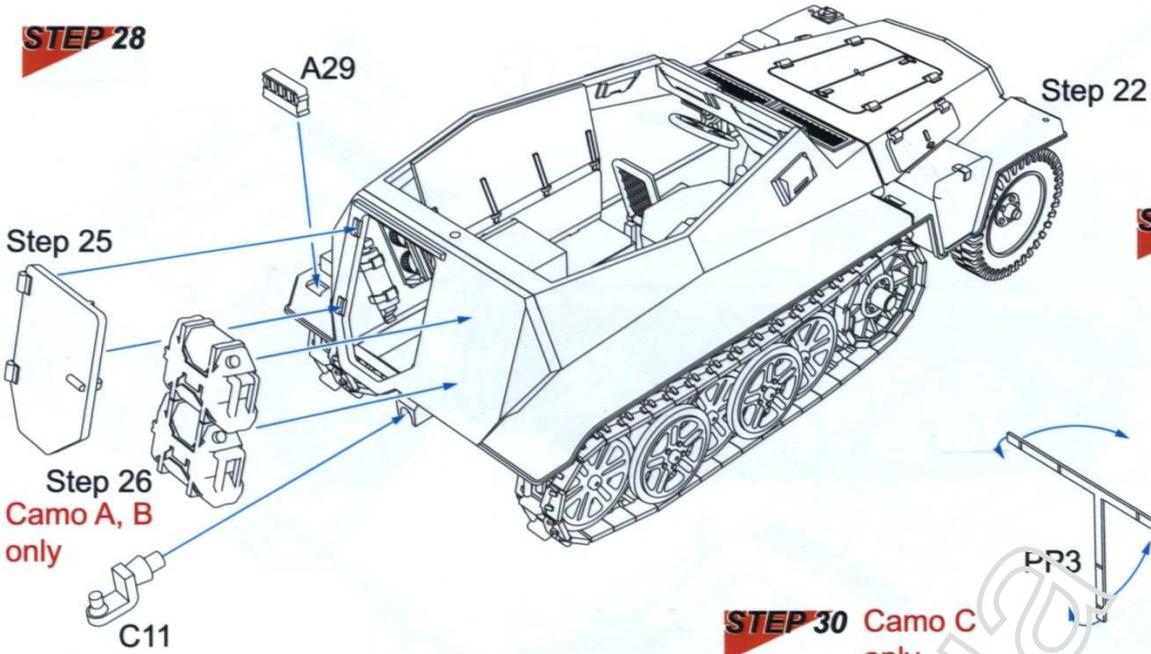

STEP 29 4x Camo C only



STEP 30 Camo C only

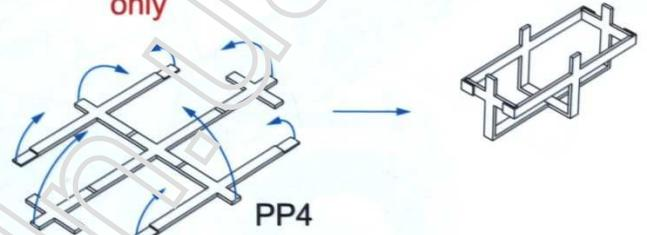

STEP 31

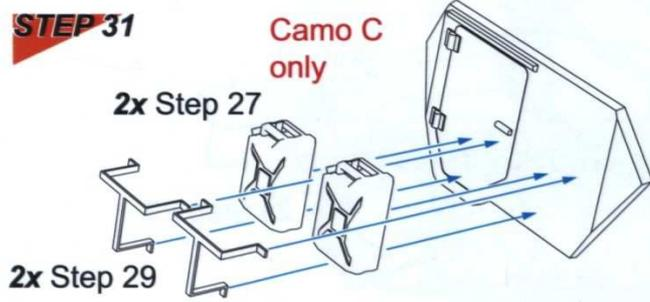

STEP 32

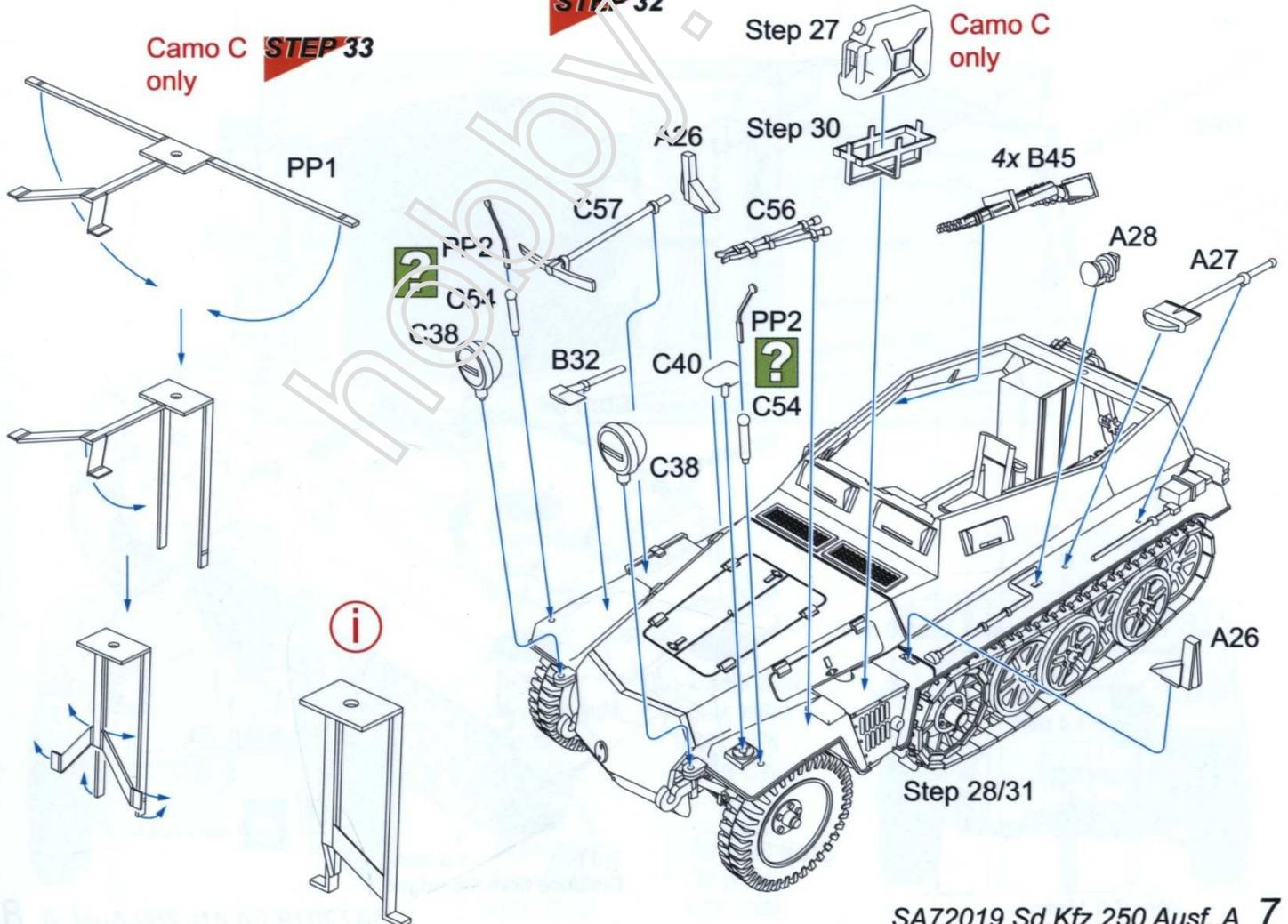

STEP 33 Camo C only

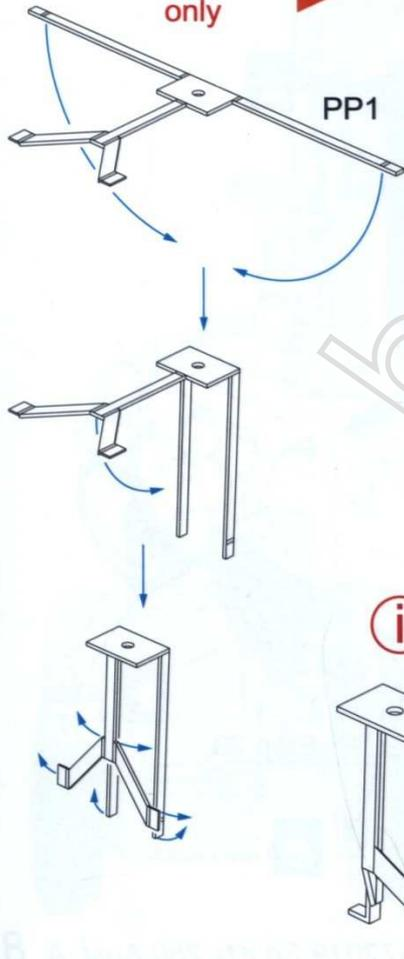

STEP 34

Camo C only 

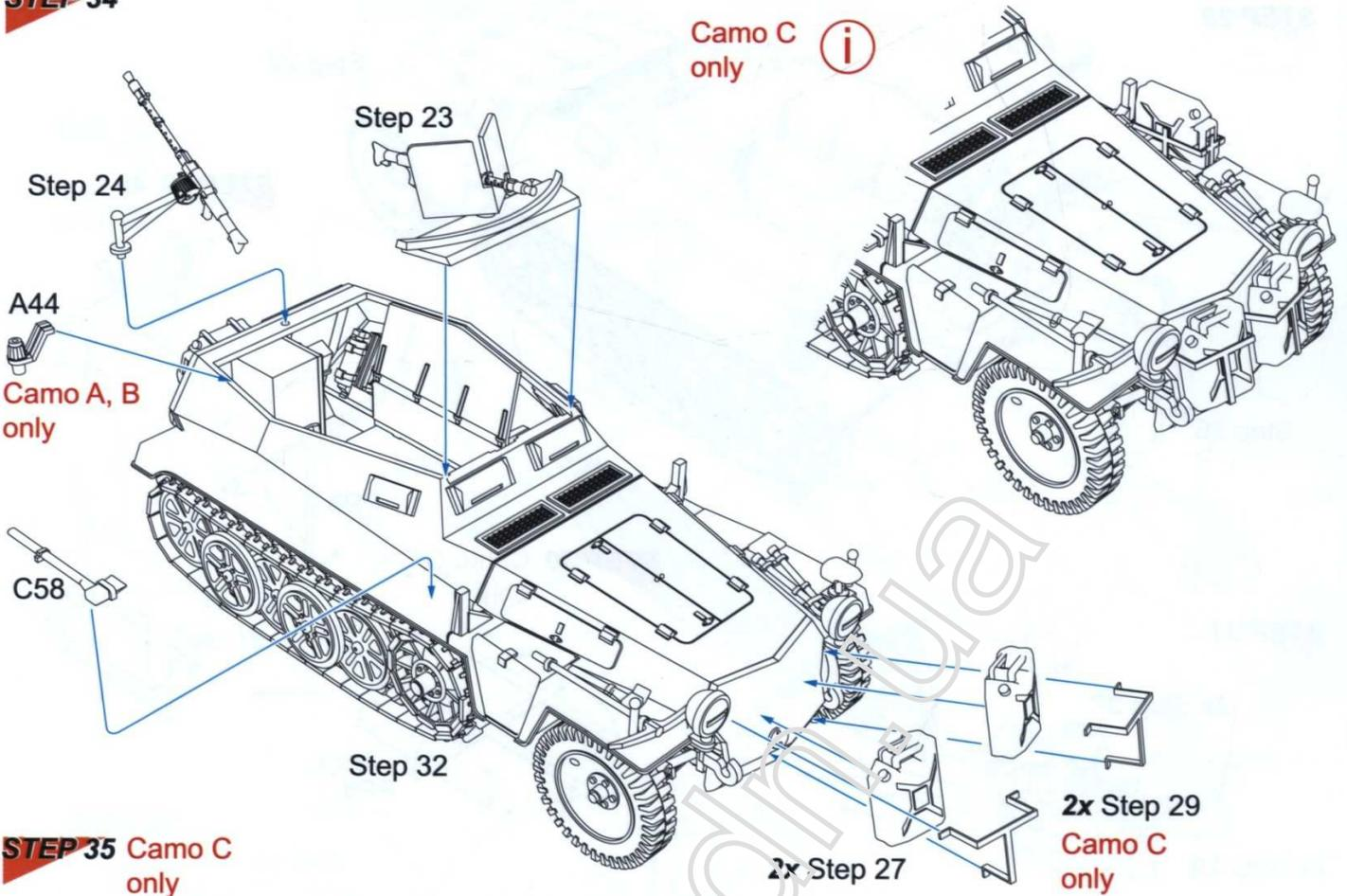

STEP 35 Camo C only

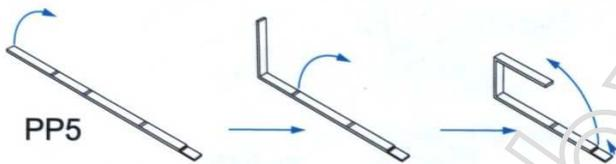

STEP 36 Camo C only



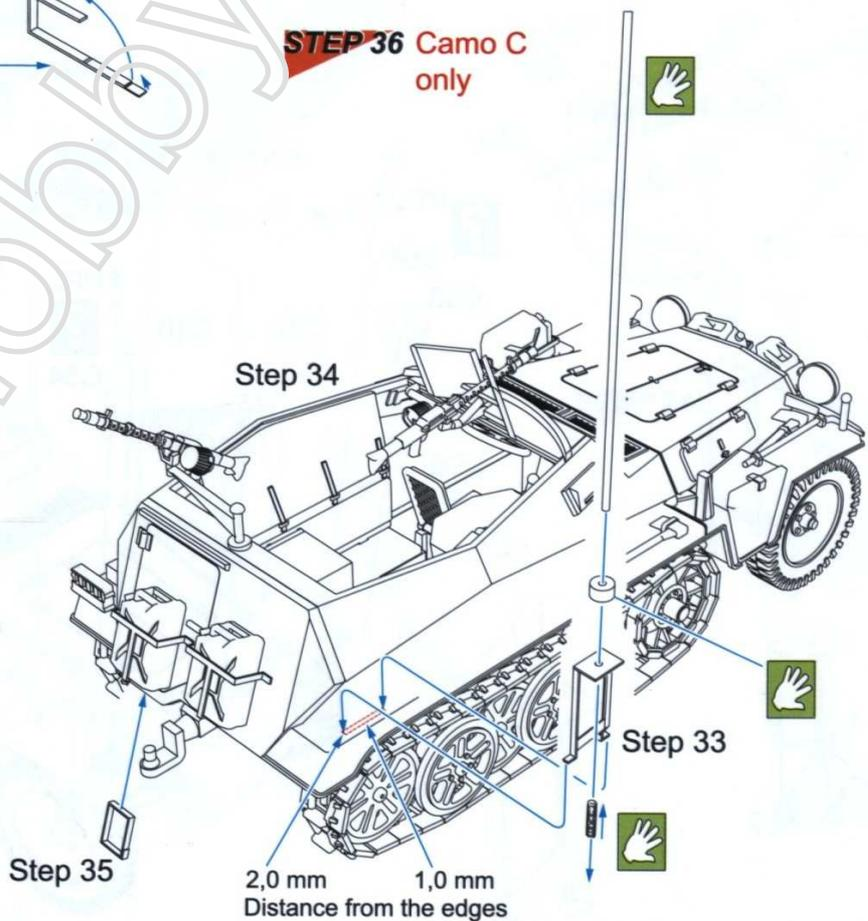
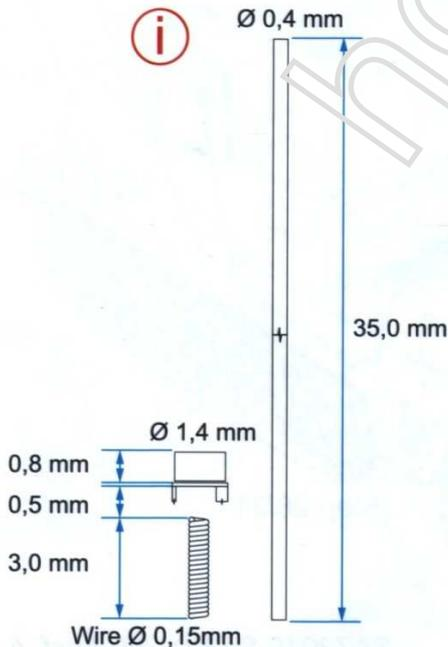

Camo A

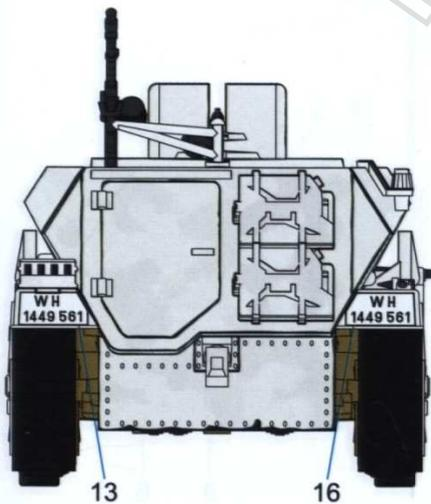
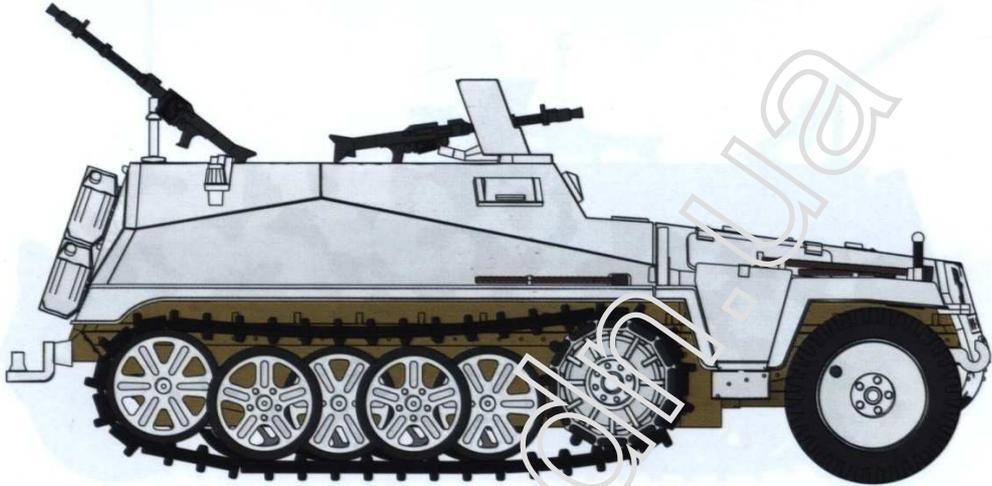
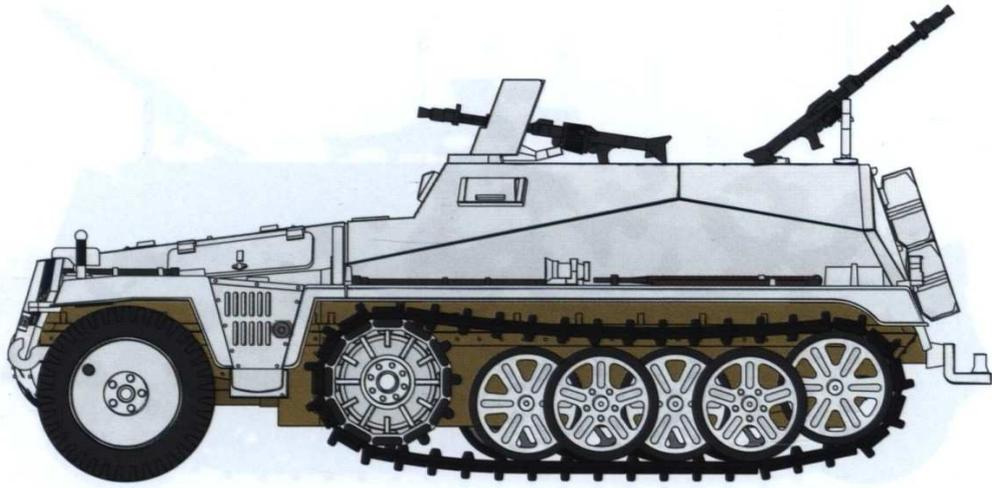

●
Ocelová
Steel
H18 / C28

●
Tank Grey
Tanková šedá
Panzergrau
H32 / C40

●
Barva pneu
Tyre Black
H77 / C137

●
Tmavá žlutá
Dark Yellow
RAL 7028
H79 / C39

○
Špinavě bílá
Off White
H21 / C69

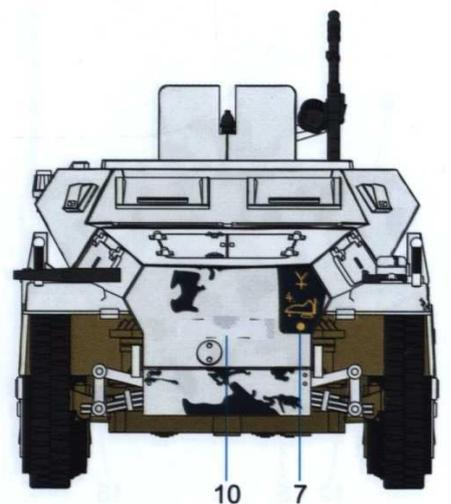

Camo B



● Tank Grey
 Tanková šedá
 Panzergrau
 H32 / C40

● Barva pneu
 Tyre Black
 H77 / C137

● Ocelová
 Steel
 H18 / C28



Camo C

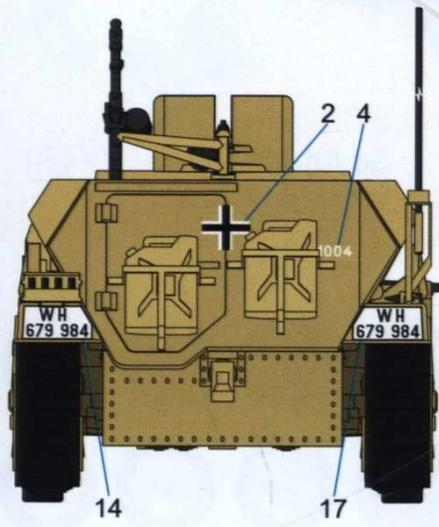
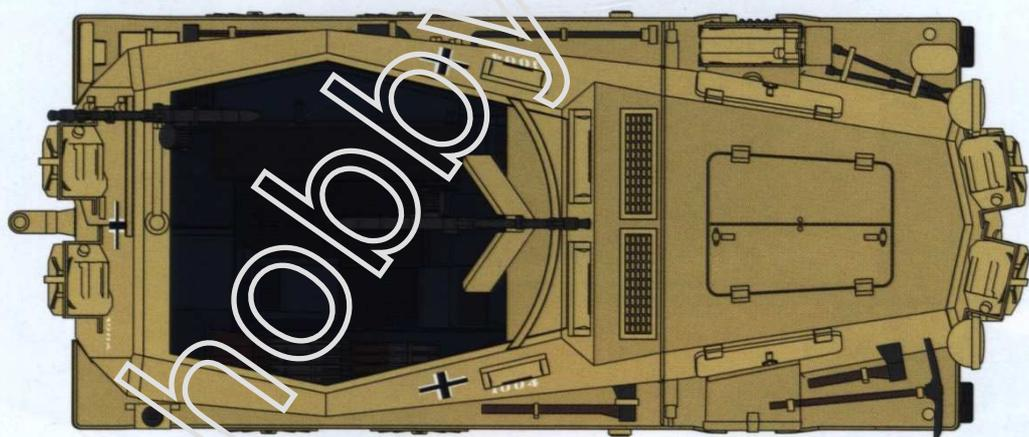
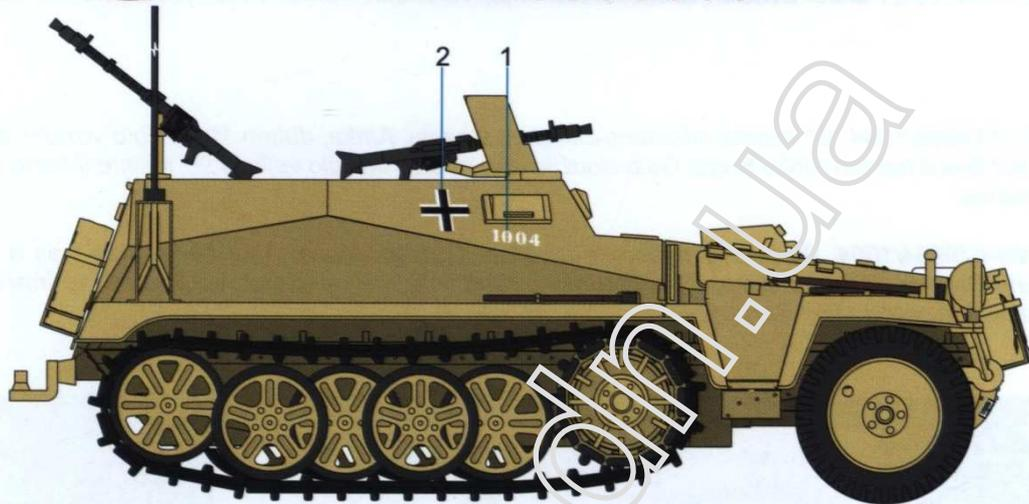
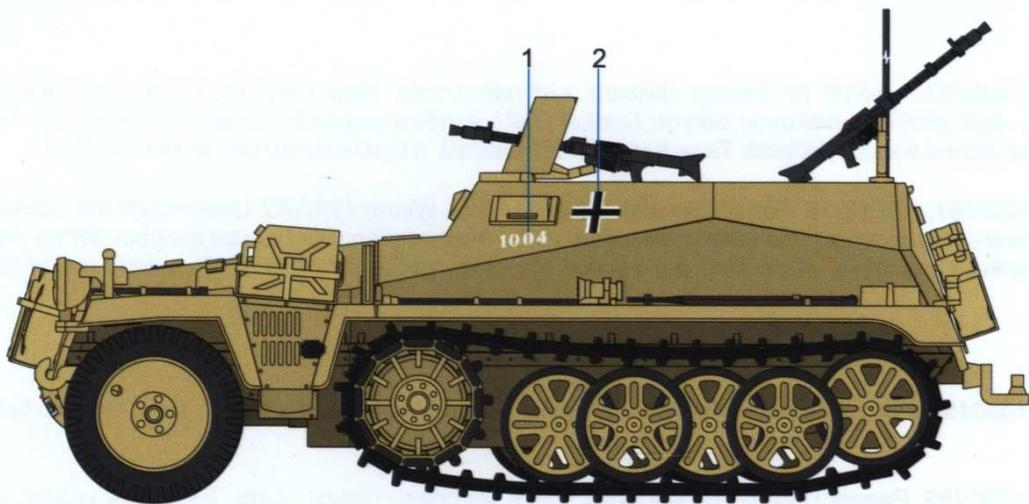

● Tank Grey
Tanková šedá
Panzergrau
H32 / C40

● Žluto hnědá
Yellow Brown
RAL 8000
H66 / C19

● Barva pneu
Tyre Black
H77 / C137

● Ocelová
Steel
H18 / C28

