

Sd.Kfz 10 Zugkraftwagen 1t (Demag D7)

EN The Sd.Kfz 10 was a military half-track vehicle designed for carrying troops and some other purposes. The German Wehrmacht commissioned the development and production of several various types of semi track vehicles of various weight categories. The DEMAG company was assigned the task to develop the lightest planned vehicle which was to tow various weaponry up to one ton of weight. A rather large number of prototypes were tested between 1934 and 1938. Eventually in 1938 the production began not only at Demag but with other plants too. The production ran until it was ceased in 1944, giving a total of about 17,500 vehicles in various versions. The first vehicles to emerge from the production line weighed 3.4t and were equipped with a Maybach NL38 TRKM engine. Later, it was replaced by a more powerful Maybach HL42 TRKM which then became a production standard for this vehicle.

The base version of the Sd.Kfz 10 was used for towing light weight pieces of artillery as were the anti-tank and anti-aircraft guns or Nebelwerfer rocket launchers. During the production, a more powerful tow mechanism was introduced which enabled the vehicle to tackle anti tank guns of to 75mm or even the sIG 33 heavy infantry gun. The chassis of the Sd.Kfz 10 had also been used later as a basis for the SdKfz 250 armoured infantry carrier, which was produced alongside the SdKfz 10 until 1944.

The Sd.Kfz 10 was produced in many varieties which differed by their purpose. They could be distinguished by the numeral after the slash. The Sd.Kfz 10/1, 10/2 and 10/3 versions were fitted for chemical and anti-chemical warfare. The Sd.Kfz 10/4 and 10/5 served as anti aircraft weapons, both being equipped with a 20mm cannon mounted on the platform, the former received the Flak 30, the latter the Flak 38. Both were produced for Wehrmacht as well as Luftwaffe units. A smaller number of the vehicles were also produced and operated as an anti-tank weapons, but did not get their specific digit after the slash.

The anti-tank versions had the 3.7cm Pak 36 or the more powerful 5cm PaK 38 cannon mounted on their platforms. The Sd.Kfz 10 type saw service on each front of the war where the Wehrmacht fought. The vehicles were used up until the end of the war, mostly in all the anti-tank varieties. The Sd.Kfz 10s were also exported abroad, in the winter of 1939-40, the Swedish military purchased a dozen of them, alongside the leFH 18 howitzers. Some more vehicles, which had been captured by Norway, were bought by Sweden after the war. In Norway, Volvo had also developed an improved, unlicensed copy during the war.

Specifications: length: 4.74 m, width 1.83 m, height: 1.62 m, max. speed 65 km/h, range 150 km.

CZ Sd.Kfz 10 bylo polopásové vozidlo určené k přepravě pěchoty a dalším účelům. Pro Wehrmacht byl plánován vývoj a výroba několika typů polopásových vozidel různých váhových kategorií. Firma DEMAG byla pověřena vývojem nejlehčího plánovaného vozidla, určená k tahání zbraní do váhy jedné tuny. Mezi lety 1934-38 bylo odzkoušeno větší množství prototypů. V roce 1938 se rozeběhla sériová výroba. To běžela nejen u DEMAGu, ale i několika dalších firem. Zastavena byla v roce 1944 a vyrobeno bylo okolo 17500 ks všech verzí tohoto vozidla. První kusy tohoto polopásového vozidla o hmotnosti 3,4 tuny, byly poháněny motorem Maybach NL38 TRKM. Ten byl nahrazen motorem Maybach HL42 TRKM. Motor HL42 se stal standardem až do konce výroby.

Základní verze SdKfz 10 byla používána jako tahač pro vleky lehčích dělostřeleckých zbraní, jako byly protitankové a protiletadlové kanóny či raketometry Nebelwerfer. V průběhu výroby bylo namontováno silnější tažné zařízení a to umožnilo tahat protitankové kanóny do ráže 75 mm nebo i polní houfnici SiG 33.

Podvozková skupina byla využita pro konstrukci pancéřového vozidla - obrněného transportéru pěchoty Sd.Kfz 250. Ten byl vyráběn souběžně také do roku 1944.

Sd.Kfz 10 byla produkovaná v mnoha variantách, lišící se určením. Rozlišovaly se číslicí za lomítkem. Varianty Sd.Kfz 10/1, 10/2 a 10/3 byly určeny k chemické a protichemické službě. Sd.Kfz 10/4 a 10/5 byly protiletadlové varianty. Obě měly na korbě lafetován kanón ráže 20 mm, v prvním případě Flak 30, ve druhém Flak 38. Byly vyráběny pro jednotky Wehrmachtu i Luftwaffe. V malém množství byly vyrobeny a bojově nasazeny i protitankové varianty. Nedostaly oficiální označení za lomítkem. Na korbě protitankových variant byl montován kanón PaK 36 ráže 3,7 cm nebo účinnější PaK 38 ráže 5 cm. Stroje Sd.Kfz 10 byly nasazeny na všech frontách, kde Wehrmacht bojoval. Byly používány do konce války a to zejména v protiletadlových variantách. Sd.Kfz 10 byl dokonce exportován. V zimě 1939/40 byly zakoupeny pro Švédské ozbrojené síly v počtu dvanácti kusů, společně s houfnicemi leFH 18. Další, kořistní Sd.Kfz 10 koupilo Švédsko z Norska po ukončení války. Volvo během druhé světové války vyvinulo upravenou

Ttd: délka: 4,74 m, šířka 1,83 m, výška: 1,62 m, max. rychlost 65 km/h, dojezd 150 km.

Parts List

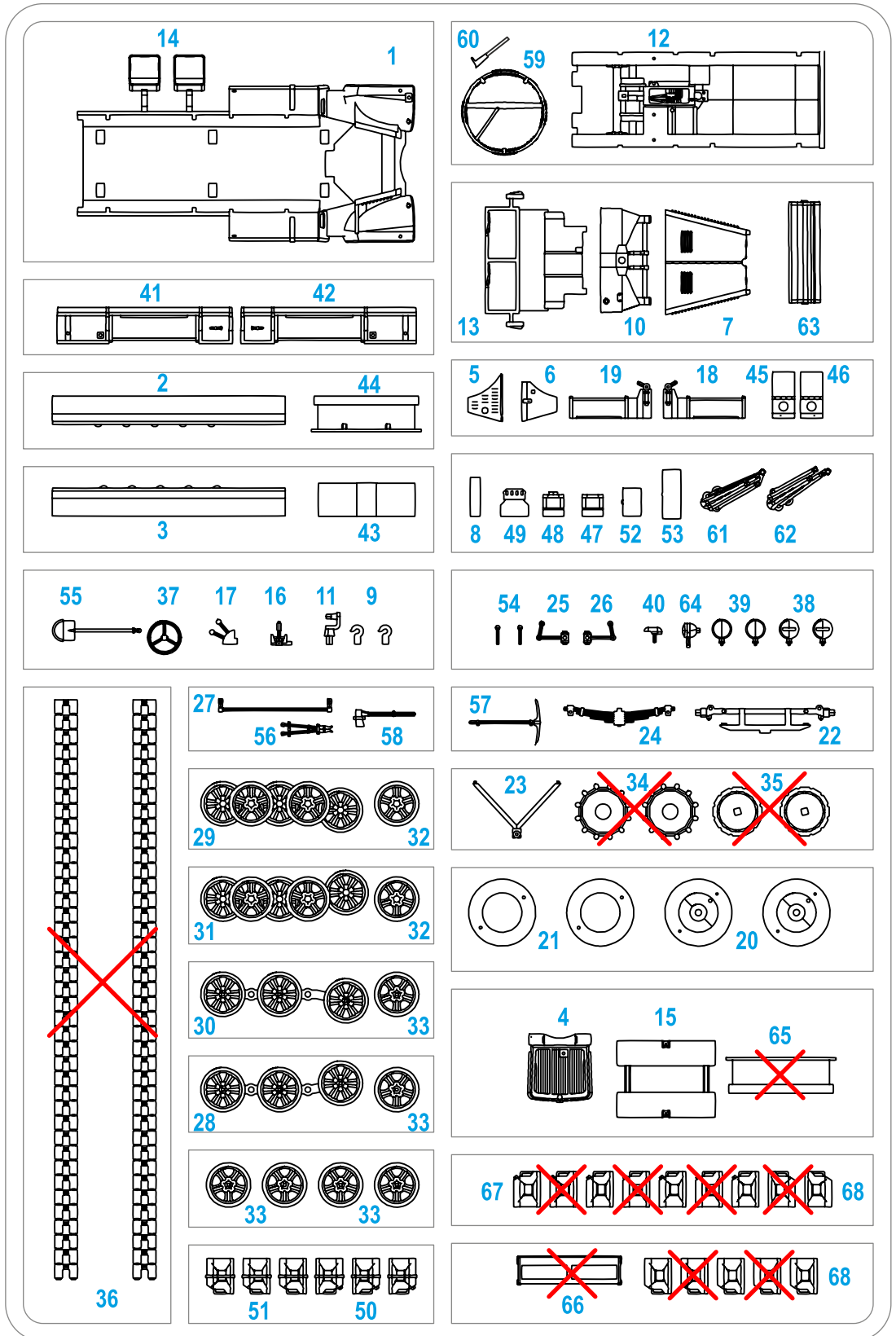
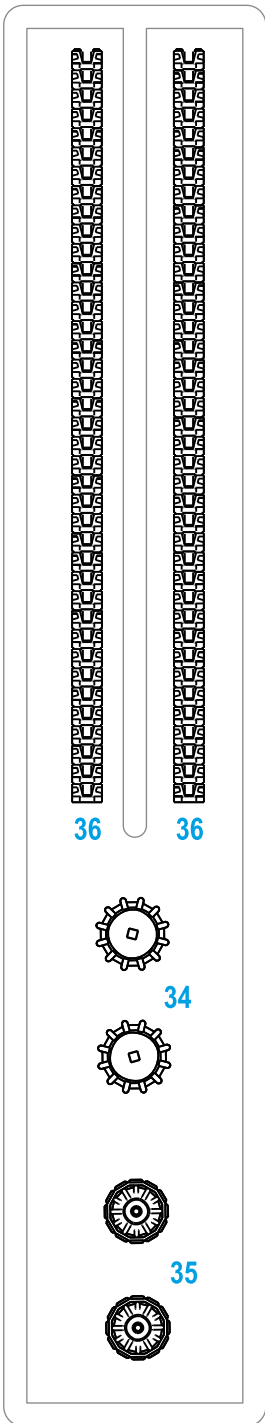

Do not use this part
Tento díl nepoužít

SYMBOLS

OPTIONAL
MOŽNOST VOLBY
NACH BELIEBEN
OPTION

INSTANT CYANOACRYLATE GLUE
POUŽÍT KYANOAKRYLÁTOVÉ LEPIDLO
ZYANOAKRYLÁTKLEBER
ADHÉSIF CYANOACRYLAT

BEND
OHNOUT
BIEGEN
COURBER

SCRATCH BUILD
ZHOTOVIT NOVÉ
FERTIGSTELLEN
ACHEVER

CUT OFF/DRILL
REZAT/VRTAT
ENTFERNEN
DETACHER

GSI COLOUR
NATRÍT
FARBEN
PEINDRE

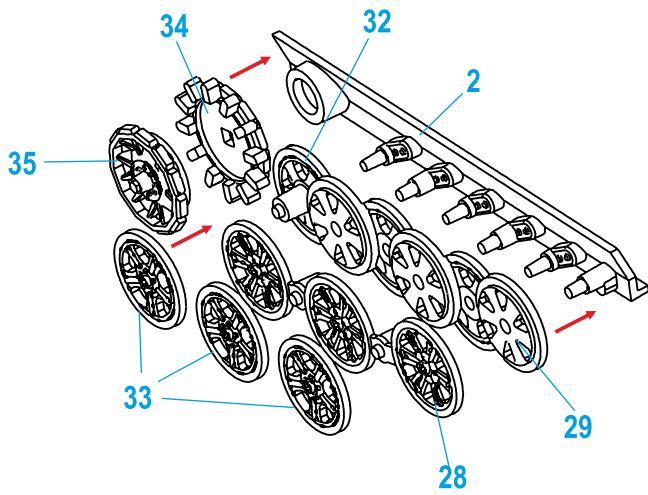
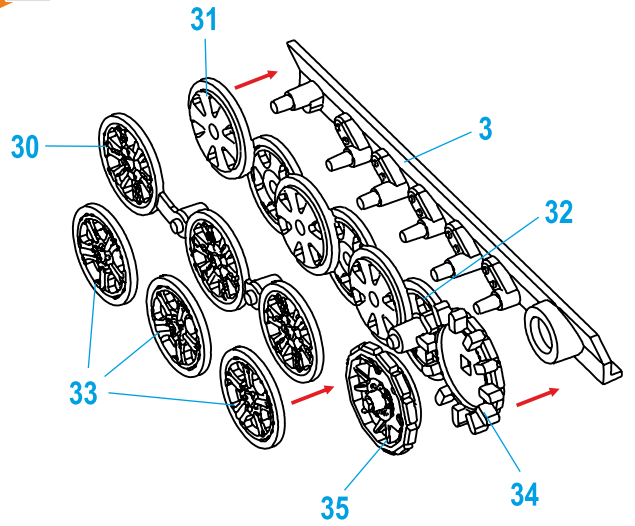
1**2**

 cut off unnecessary links

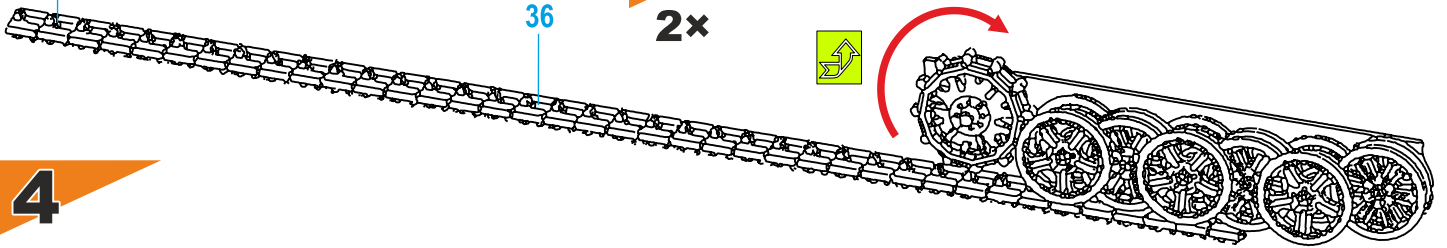
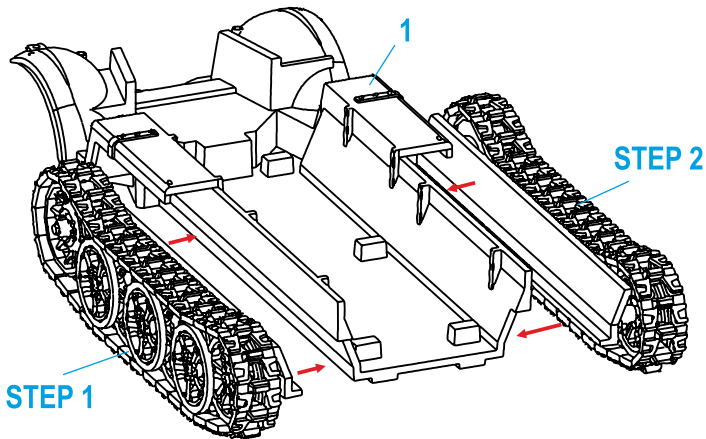
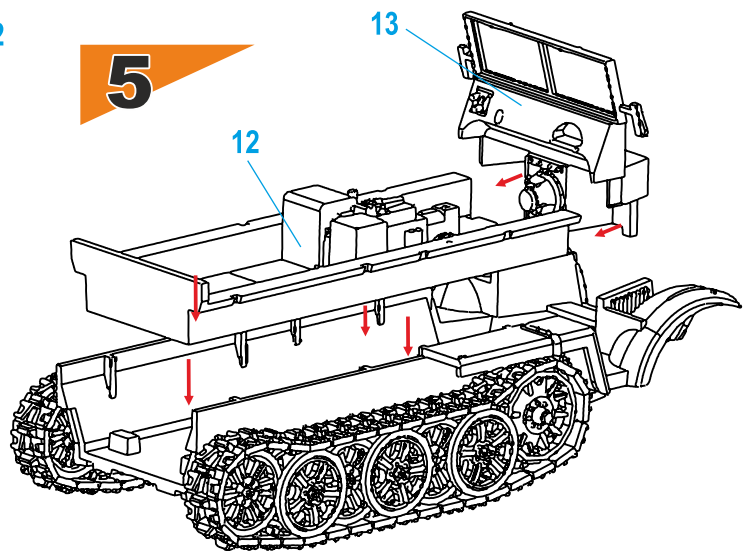
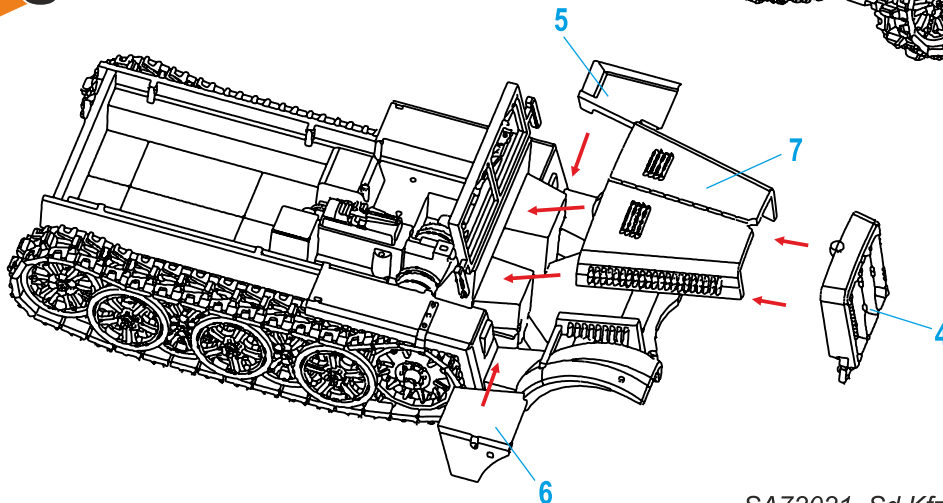
3
2x**4****5****6**

 **Windscreen**
(clear film)

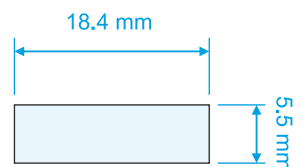

7

2x

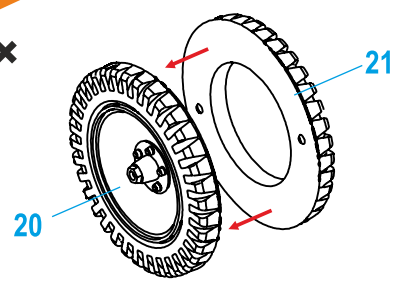

8

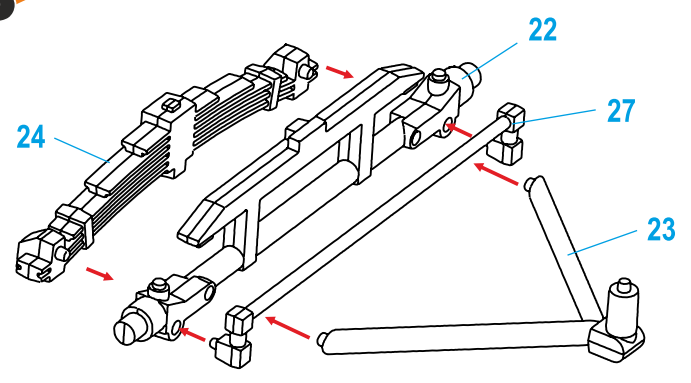

9

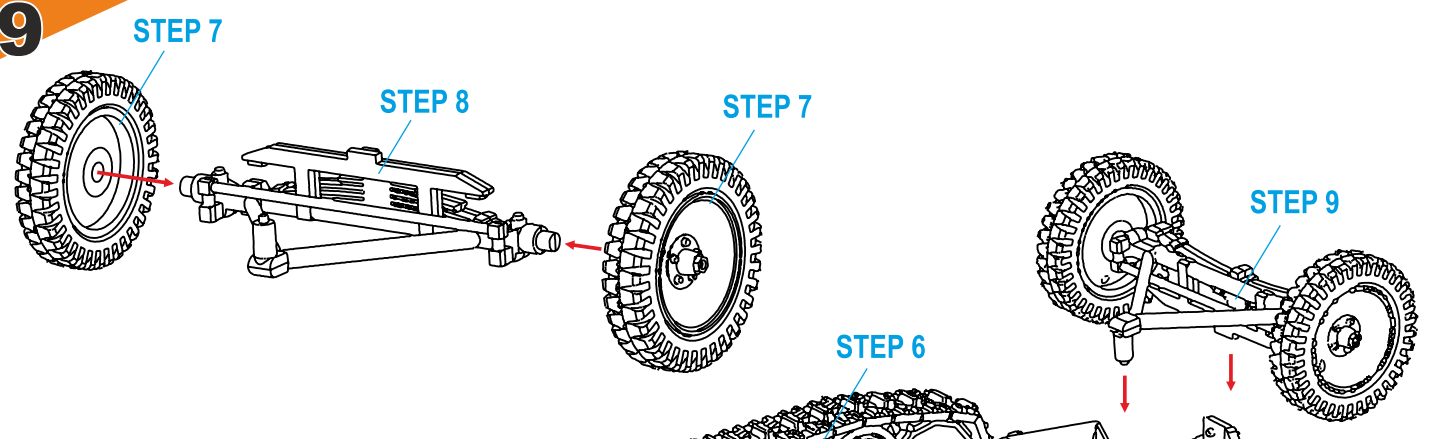

10

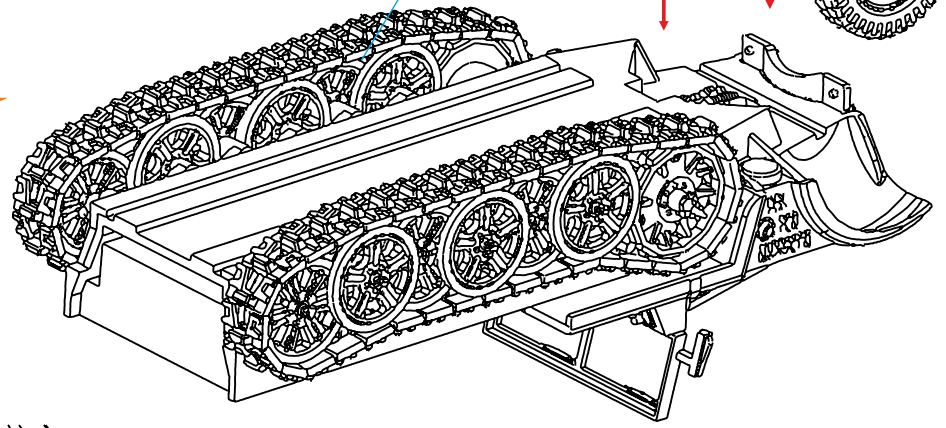

11

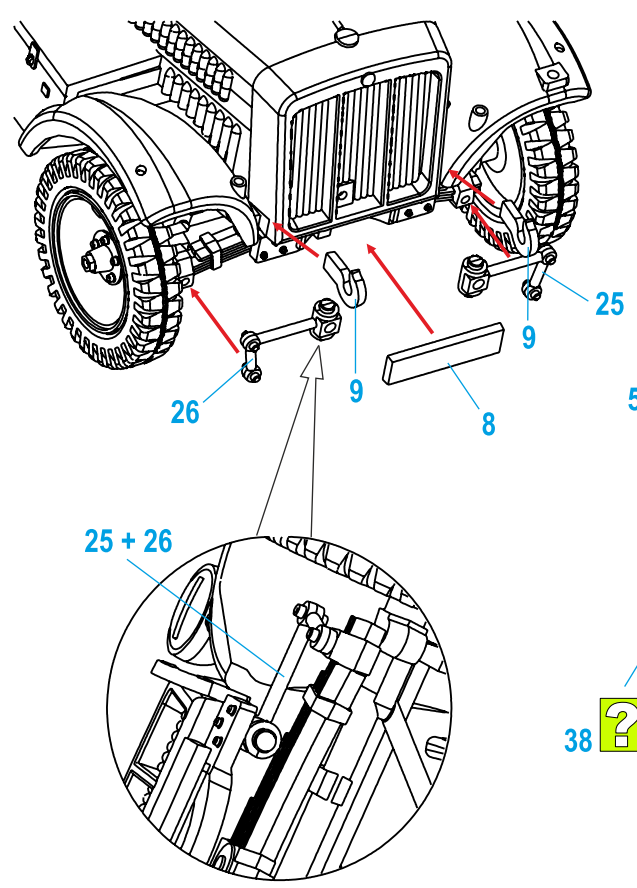

12

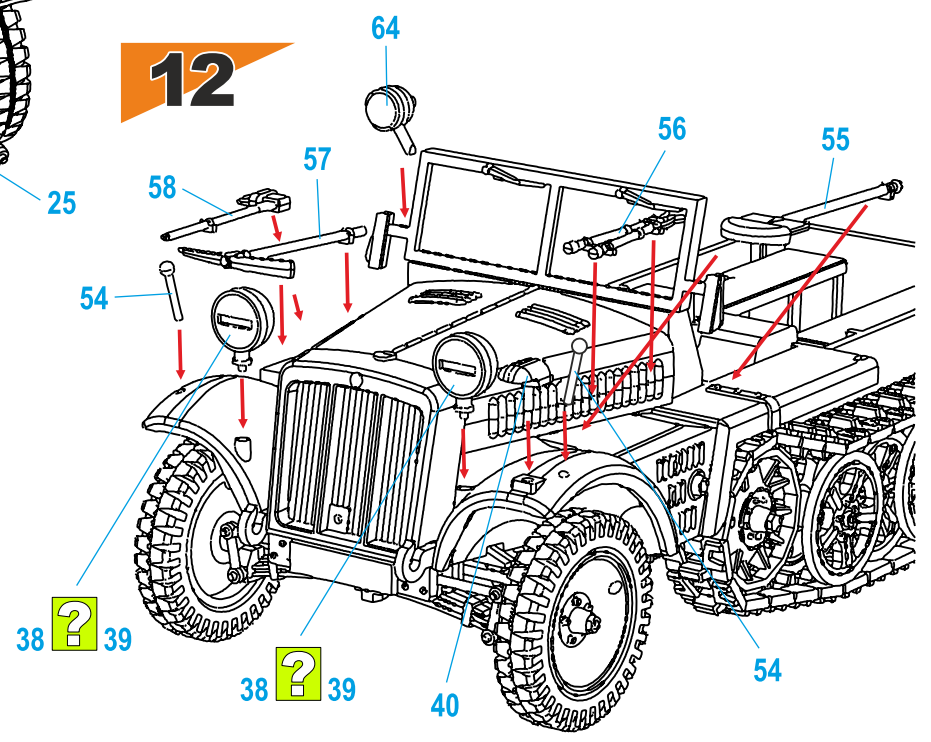

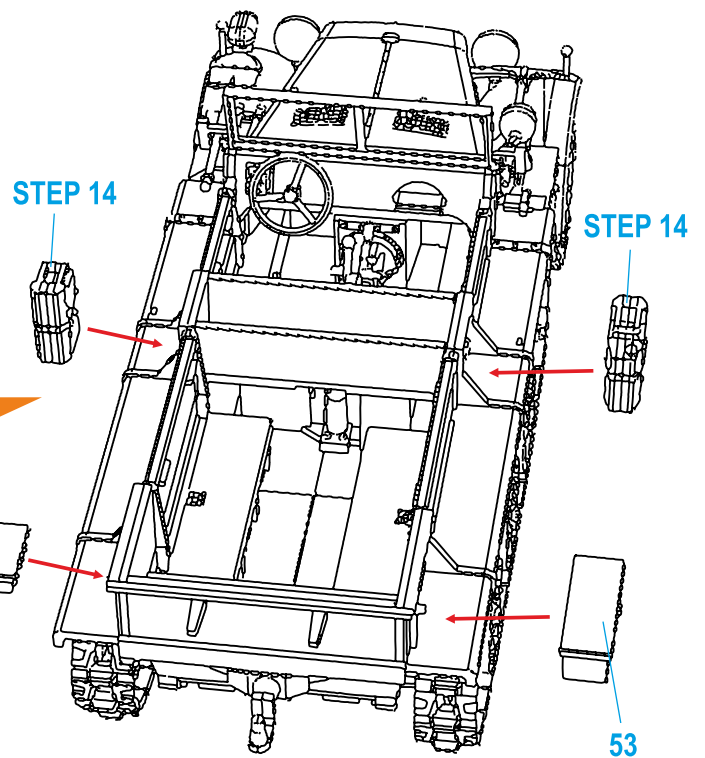
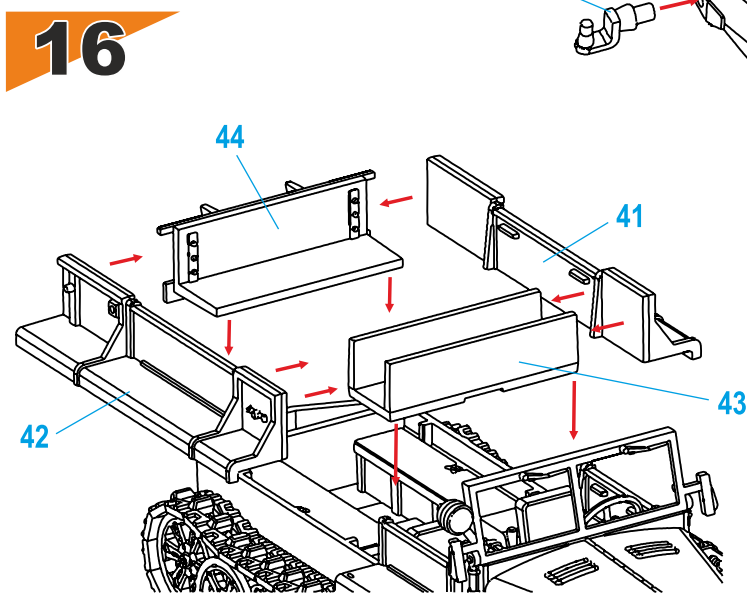
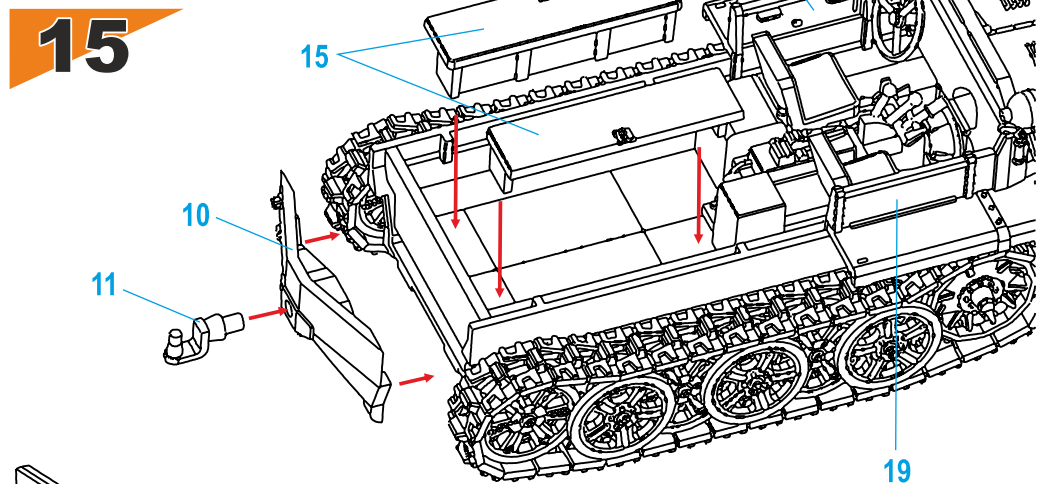
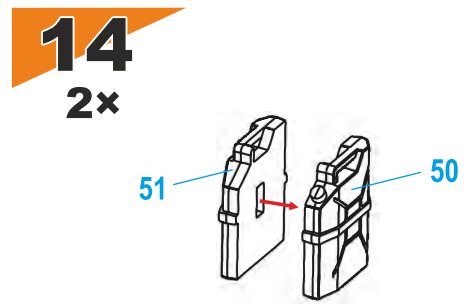
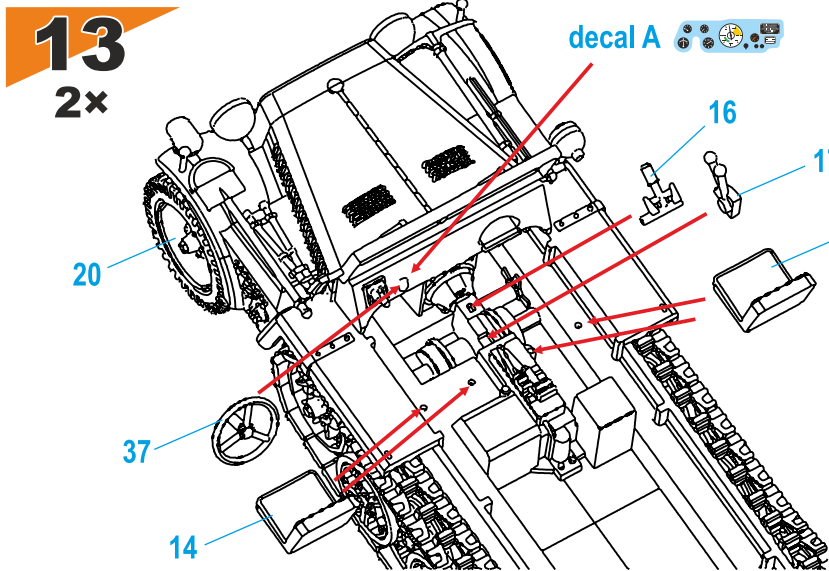

19

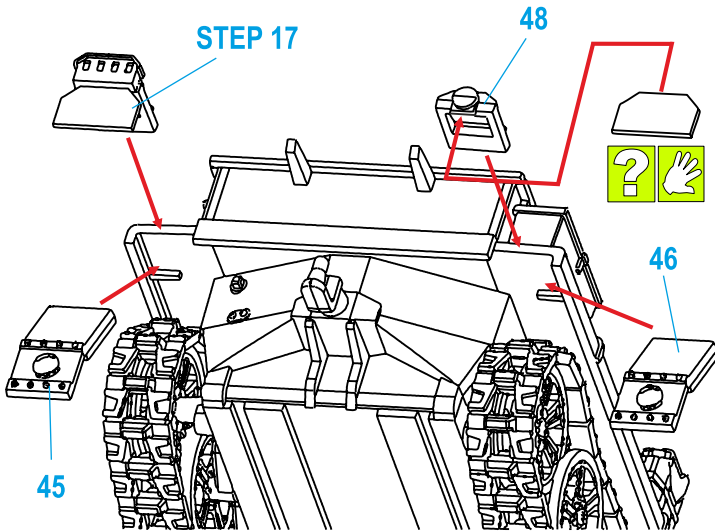

20

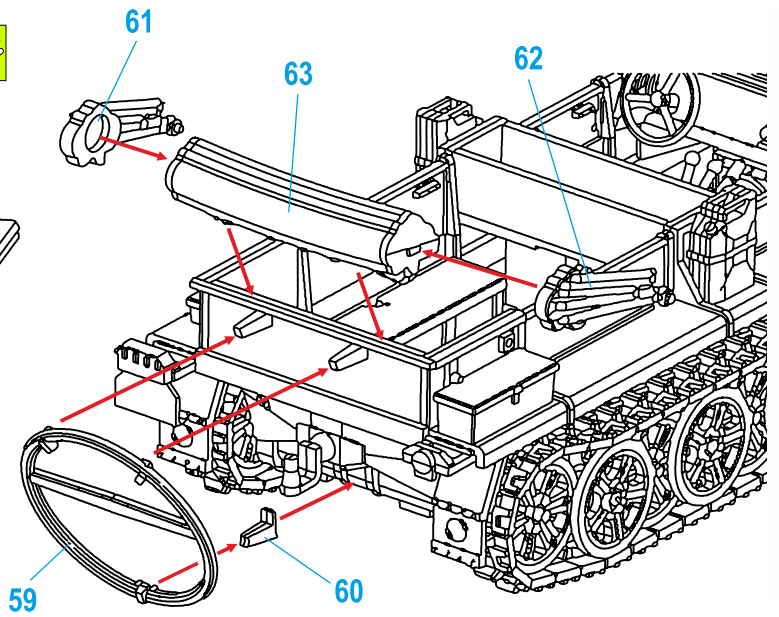

21

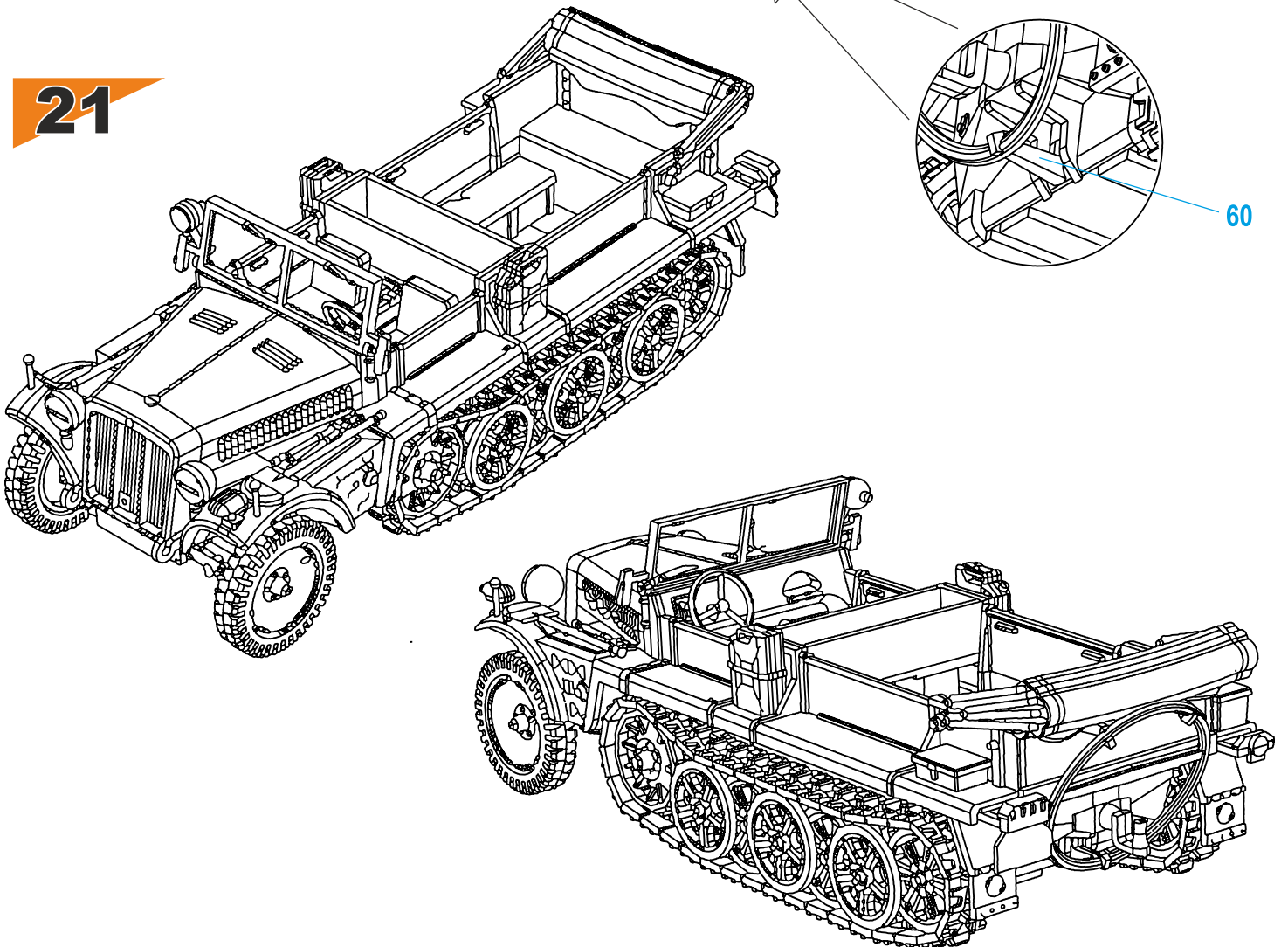

Sd.Kfz 10, unknown combat unit, Wehrmacht, Russia 1942.

Sd.Kfz 10, neznámá bojová jednotka Wehrmachtu, Rusko 1942.

Camo A

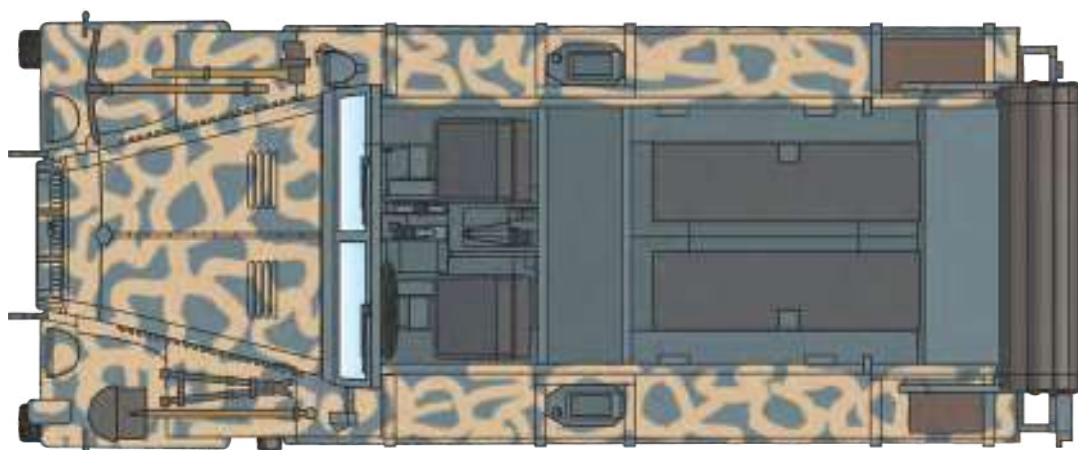
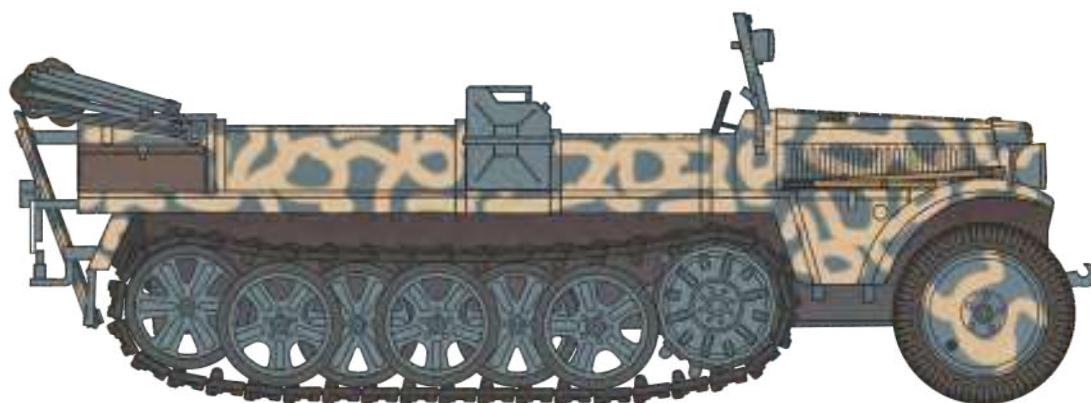
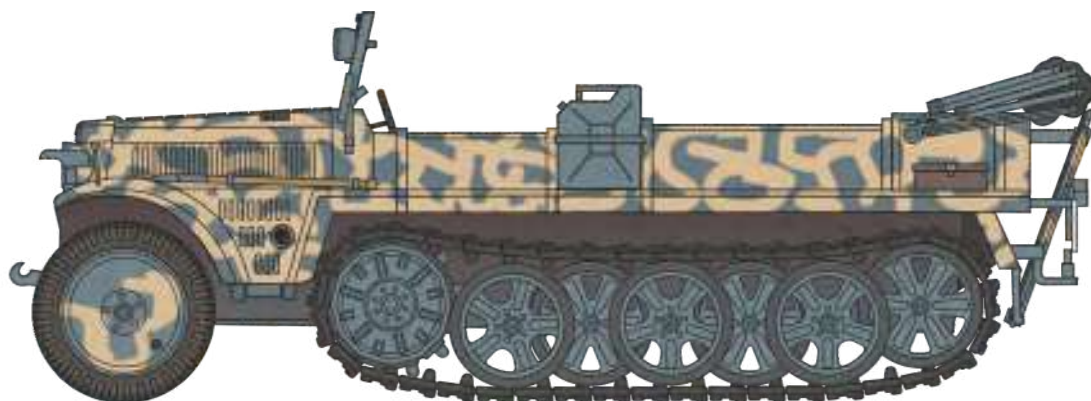

Field Gray
Polní šedá
Panzergrau
H32 / C40

Dark Yellow
Tmavě žlutá
Dunkelgelb
H79/C39

Tyre Black
Barva pneu
H77/C137

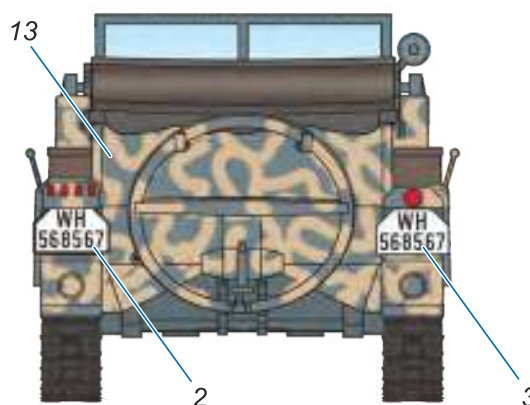
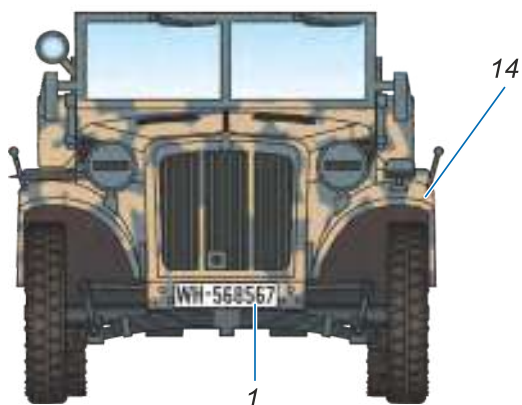

Sd.Kfz 10, Adler-built vehicle, unknown combat unit, Wehrmacht, Poland, Autumn 1939.

Sd.Kfz 10, stroj vyrobený firmou Adler, neznámá bojová jednotka Wehrmachtu, Polsko, podzim 1939.

Camo B

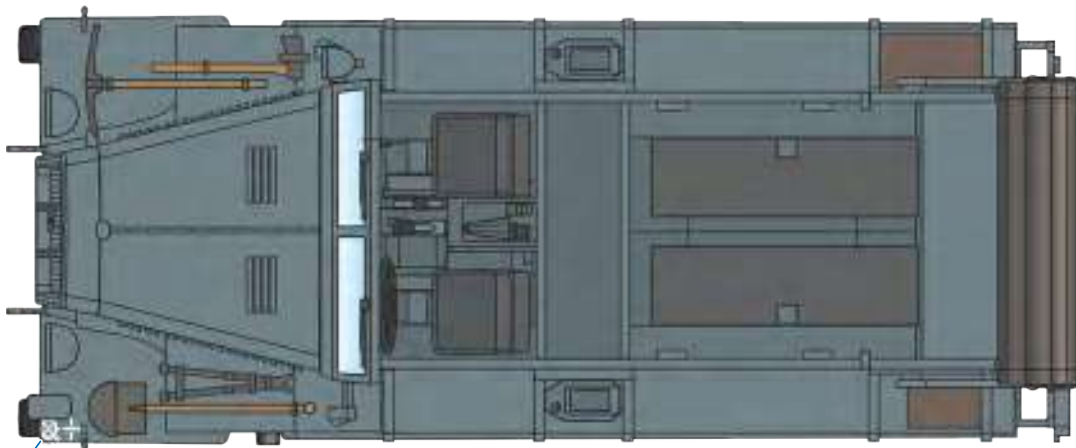
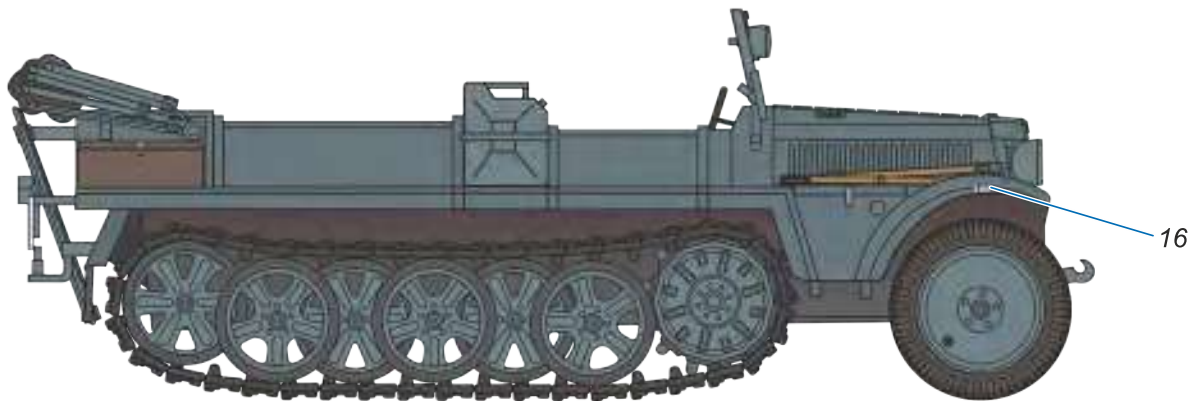
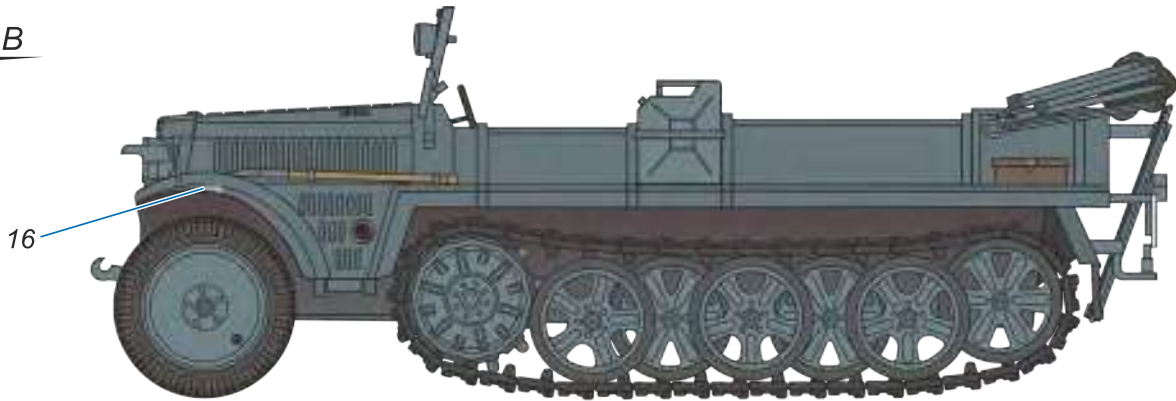

Field Gray
Polní šedá
Panzergrau
H32 / C40

Tyre Black
Barva pneu
H77/C137

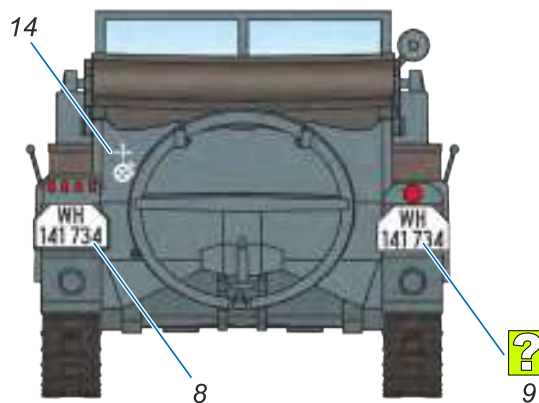
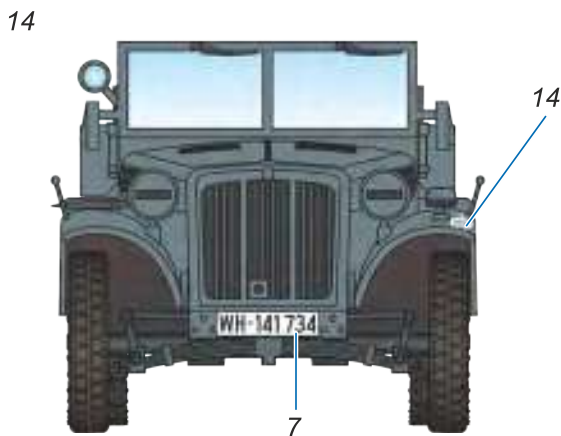

Sd.Kfz 10, Demag-built vehicle, unknown combat unit, Wehrmacht, Yugoslavia territory, Summer 1942.

Sd.Kfz 10, stroj vyrobený firmou Demag, neznámá bojová jednotka Wehrmachtu, území Jugoslávie, léto 1942.

Camo C

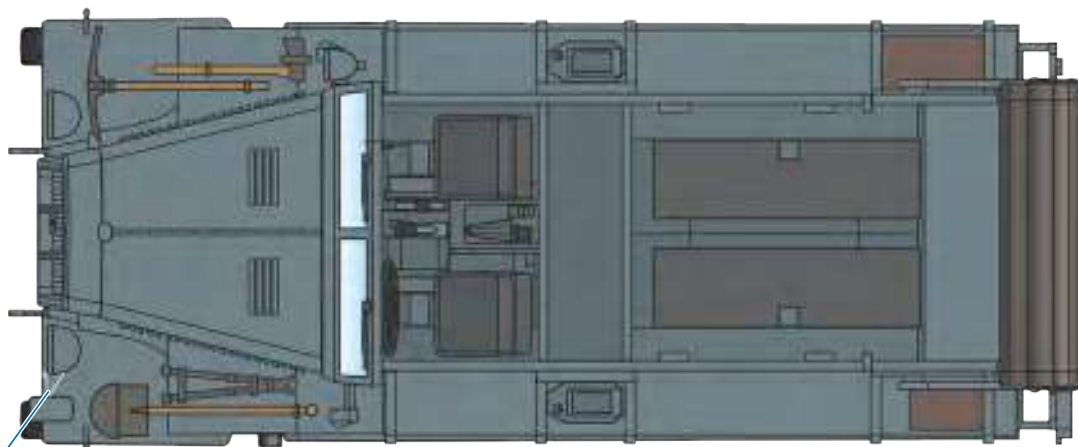
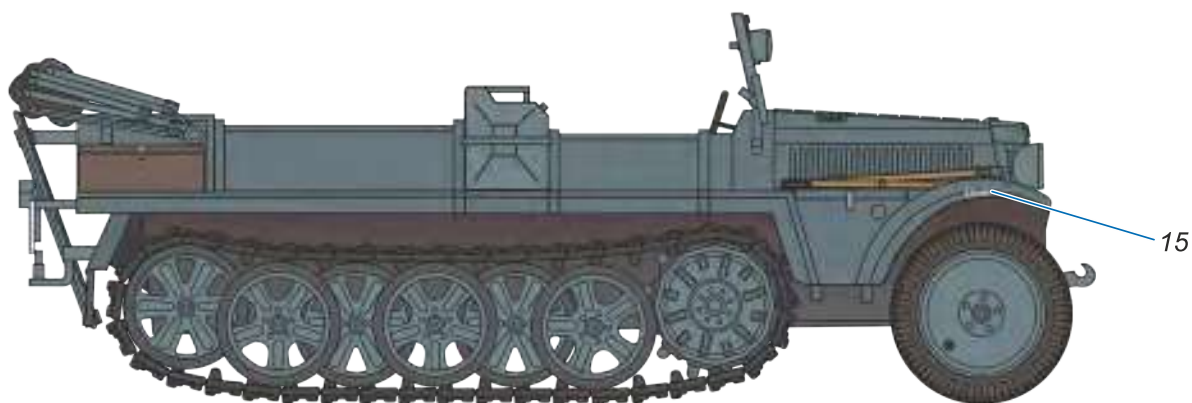
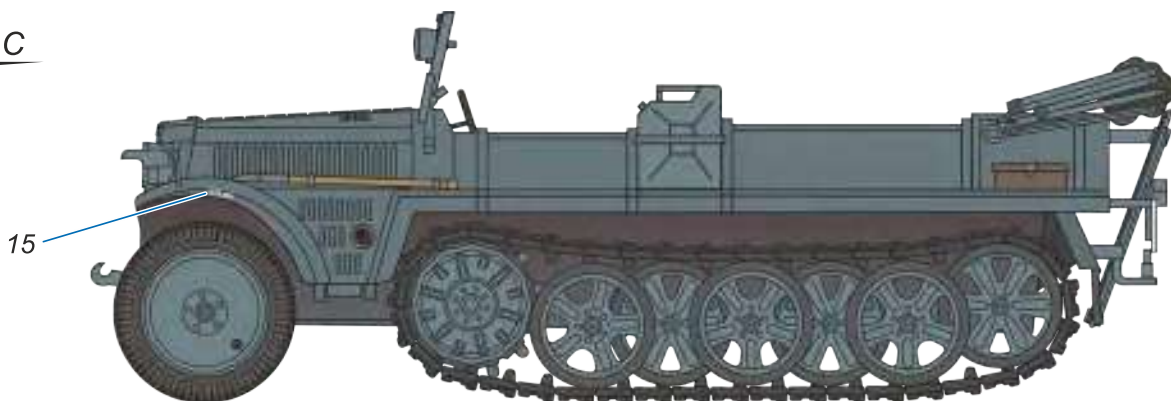

13

Field Gray
Polní šedá
Panzergrau
H32 / C40

Tyre Black
Barva pneu
H77/C137

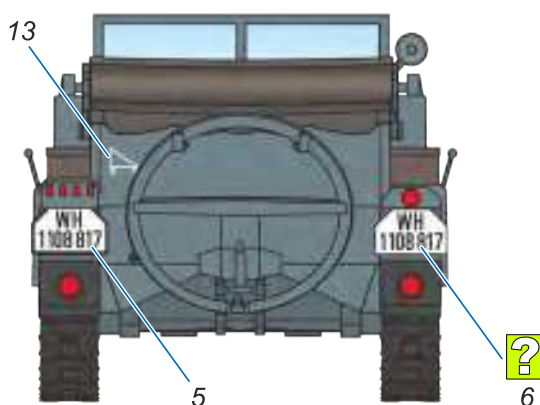
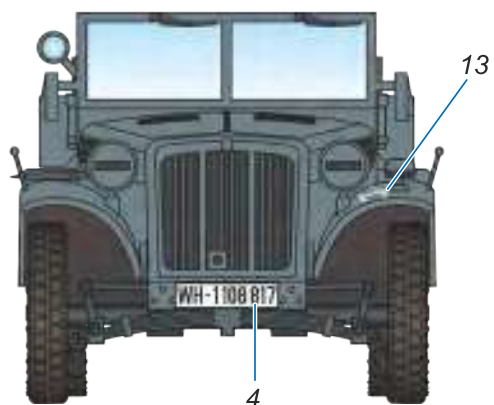

Sd.Kfz 10, unknown combat unit, Wehrmacht, Veselí nad Lužnicí, Protectorate of Bohemia and Moravia (Czechoslovakia), May 1945 .

Sd.Kfz 10, neznámá bojová jednotka Wehrmachtu, Veselí nad Lužnicí, Protektorát Čechy a Morava (Československo), květen 1945.

Camo D

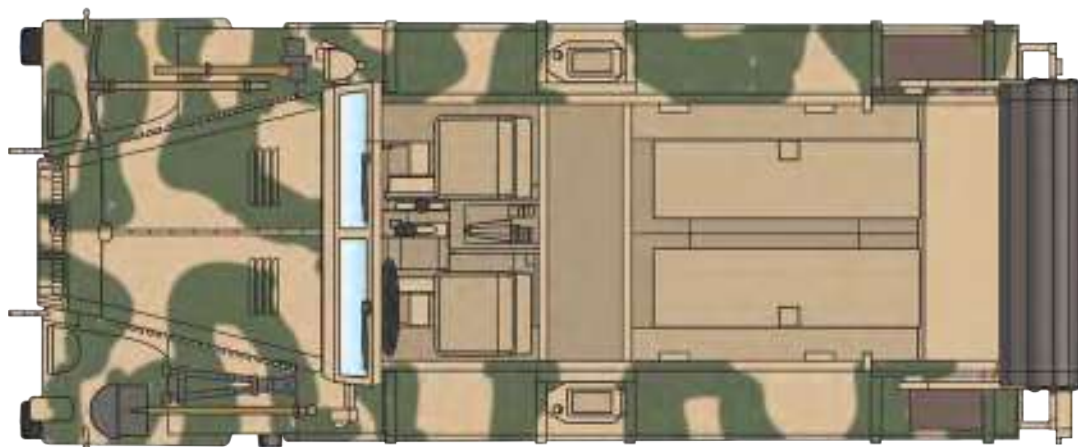
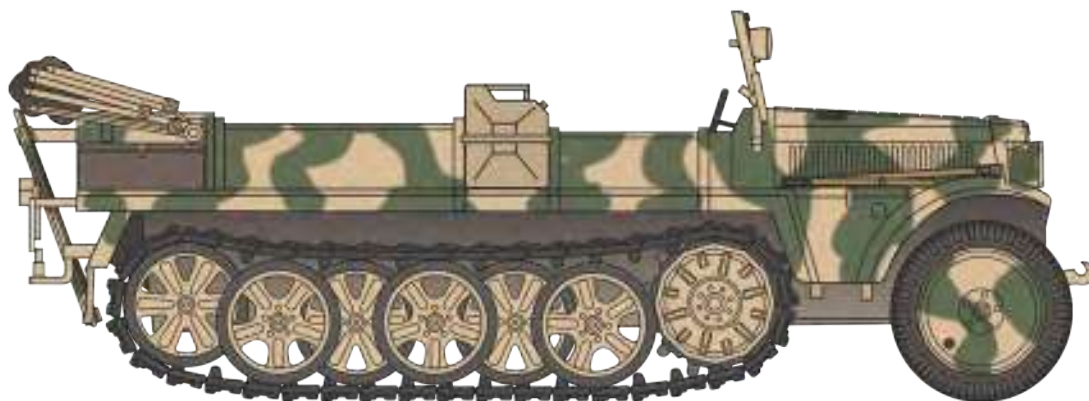
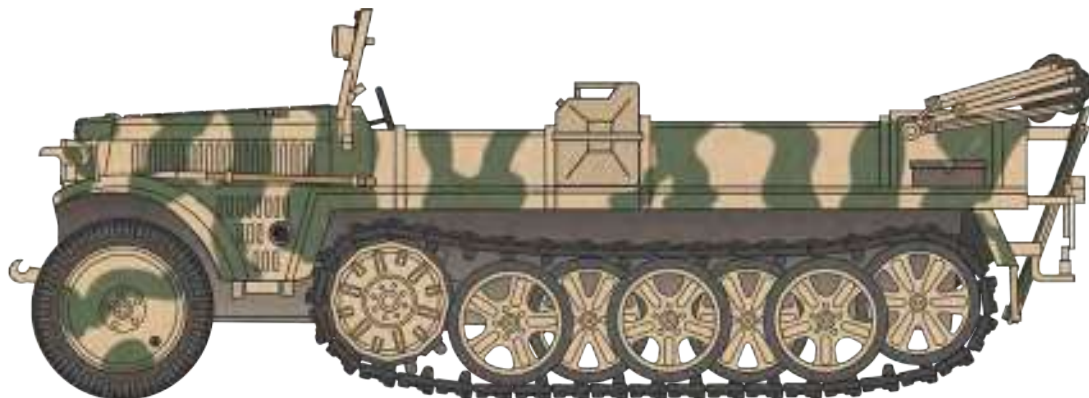

-  Dark Yellow
Tmavě žlutá
Dunkelgelb
H79/C39
-  Olive Green
Olivově zelená
Olivgrün
H420/C120
-  Tyre Black
Barva pneu
H77/C137

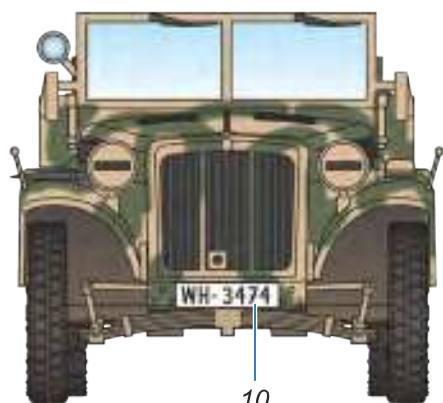

10

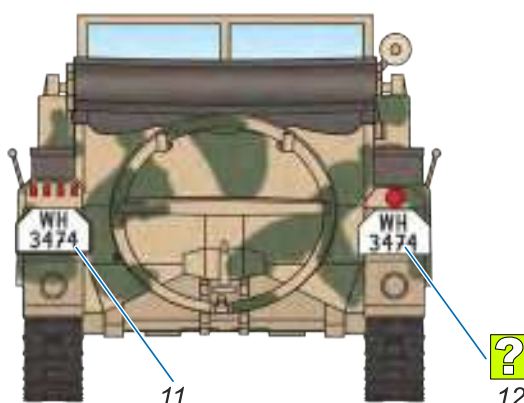

11

12



IMPROVE YOUR MODEL WITH THIS HIGHLY DETAILED
RESIN WHEEL SET B72094



BLITZ Line
ARMOUR ACCESSORIES

special
HOBBY

Special Hobby 1/72 Scale Kits
Within Special Armour Line

special
ARMOUR

SA72002



Sd.Kfz 11 (3t)

SA72003



A4/V2

SA72014



A4/V2 Prototypes

SA72020



'German Tank Destroyer'
Marder II (Sd.Kfz 131)

SA72009



Vidalwagen V2 Transporter

SA72012



Meillerwagen V2 Transporter

SA72015

'Liquid Oxygen Tank for V2 Rocket'



A-Stoffanhänger

ATTRACTIVE 1/72 SCALE KITS OFFERED BY

Aspecial *special*
ARMOUR NAVY



SA72006 1/72
Biber
German Midget Submarine

N72025 1/72
WWII German Torpedo
Type G7e
(3 pcs) Detailed resin weapon for
the Biber and other CMK U-Boots

SA72001 1/72
SS-100 Gigant
Schwerer Radschlepper / Heavy Tractor



B72102 1/72
Biber Trailer
Wheels



B72094 1/72
SS-100 Gigant
Wheels

USE CMK TOOLS AND WEATHERING PIGMENTS FOR YOUR KITS

H1010 handle for our saws
priceless tool for resin
parts adjustment



H1011 CMK sanding stick
four different grit
of sanding papers on
one sanding stick



Star Dust
weathering pigments

All of the above items can be found and ordered via our official
website and e-shop: WWW.CMKKITS.COM, WWW.SPECIALHOBBY.EU

