



## **EoN Eton TX.1**

### **SG-38 Over Western Europe**



When the SG-38 elementary training glider was designed by Rehberg, Schneider and Hoffmann, its constructors could not have guessed just how famous it would become. This glider very soon became a standard training machine for the NSFK which was mass produced by several factories and it could also be home-built from drawings sent by post. Production was not restricted solely to Germany either and the basic design went on to be built throughout the world, making it the most widely used training glider ever known. The type was built within most European countries under a variety of different designations and amongst them was Slovakia which began production during WW2 and in post war years they continued to be built for aeroclubs in Czechoslovakia as the ŠK-38 Komar (Gnat) where they were used alongside some original ex-German SG-38 aircraft.

Wingspan: 10,40 m, Length: 6,28 m, Empty weight: 100 kg, Max. speed: 115 km/h, Max. glide ratio: 10:1 at 52 km/h



Když pánové Rehberg, Schneider a Hoffmann navrhli kluzák pro základní výcvik SG-38 Schulgleiter, jistě netušili, jak slavný letoun stvořili. Kluzák se totiž brzy stal standardním kluzákem pro NSFK a byl vyráběn jak amatérsky podle zasílaných plánů, tak sériově v několika továrnách. A to jak v Německu, tak i v jiných státech, např. za války na Slovensku. Dalo by se říci, že minimálně v Evropě ho snad postavili úplně všude. Stal se nejmasověji vyrobeným školním kluzákem světa. Po druhé světové válce byla vyrobena série SG-38 s označením ŠK-38 Komár i pro československé aerokluby. Tyto nově vyrobené kluzáky pak u nás sloužily společně s kořistními. Kořistní kluzáky používali po válce i v Polsku, Francii, a jinde v Evropě.

rozpětí: 10,40 m, délka: 6,28 m, prázdná váha: 100 kg, max. rychlost: 115 km/h, max. klouzavost: 10:1 při 52 km/h

# Plastic Part

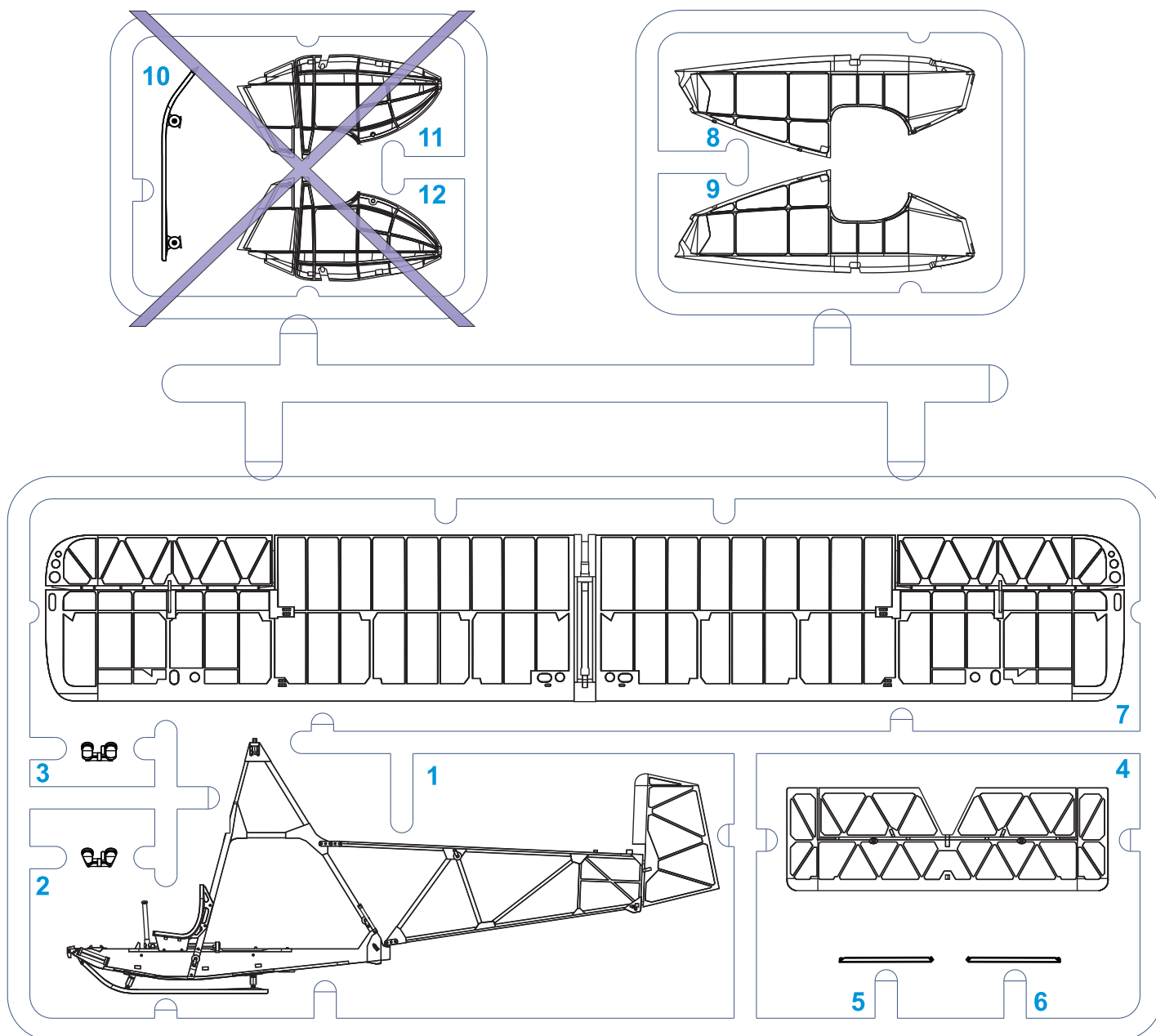

## Barvy GUNZE/ GUNZE Colour No.

|          |                             |           |
|----------|-----------------------------|-----------|
| <b>A</b> | Bílá/ White                 | H1/C1     |
| <b>B</b> | Červená/ Red                | H3/C3     |
| <b>C</b> | Modrá/ Blue                 | H5/C5     |
| <b>D</b> | Černá/ Black                | H12/C33   |
| <b>E</b> | Plátno/ Fabric              | H27/C44   |
| <b>F</b> | Barva dřeva/ Wood           | H66/C119  |
| <b>H</b> | Černá na pneu./ Tire Black  | H77/C137  |
| <b>I</b> | RLM 83 Zelená/ RLM 83 Green | H423/C423 |
| <b>J</b> | Tmavý kov/ Dark Metal       | MC214     |
| <b>K</b> | Hliník/ Aluminium           | MC218     |

## SYMBOLS

**?** MOŽNOST VOLBY  
OPTIONAL  
NACH BELIEBEN  
OPTION

POUŽÍT KYANOAKRYLÁTOVÉ LEPIDLO  
INSTANT CYANOACRYLATE GLUE  
ZYANOAKRYLÁTKLEBER  
ADHÉSIF CYANOACRYLAT

OHNOUT  
BEND  
BIEGEN  
COURBER

ZHOTOVIT NOVĚ  
SCRATCH BUILD  
FERTIGSTELLEN  
ACHEVER

ŘEZAT/VRTAT  
CUT OFF/DRILL  
ENTFERNEN  
DETACHER

GSI **A**  
colours code  
NATRÍT  
COLOUR  
FARBEN  
PEINDRE

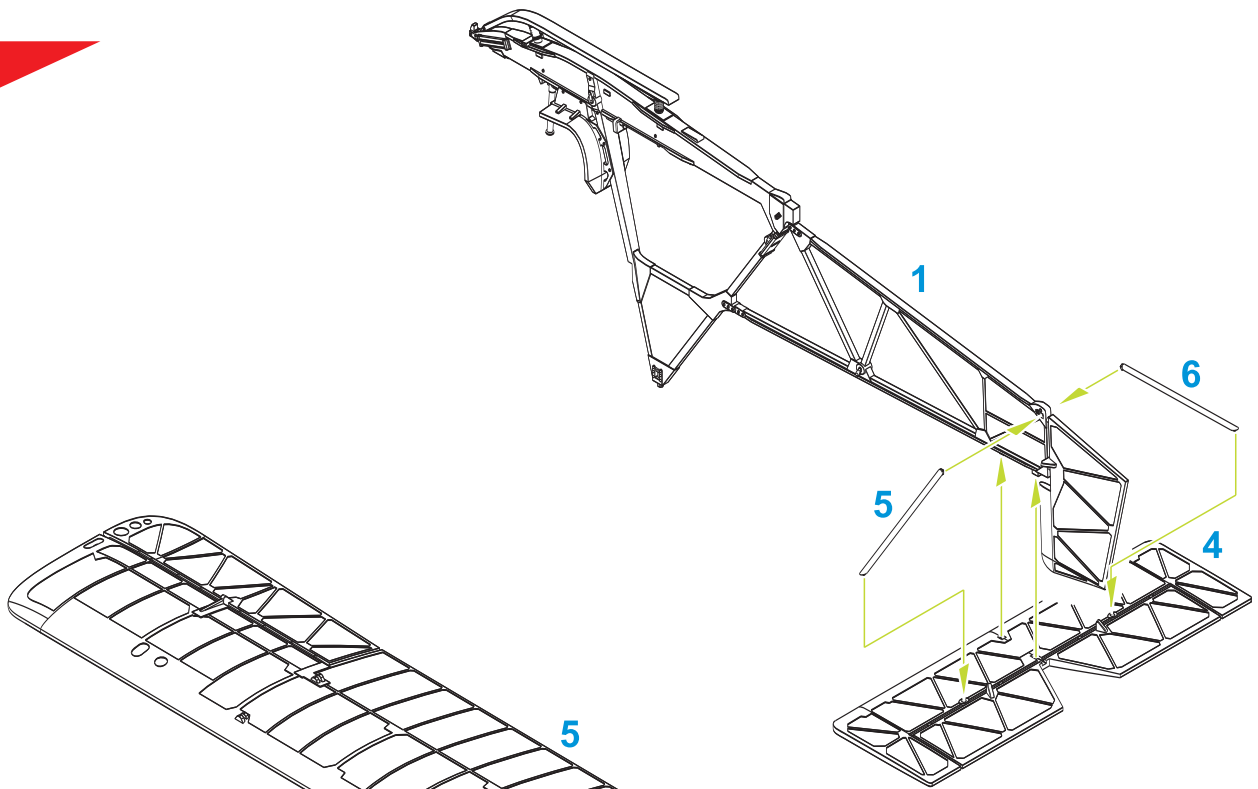
**1****2****NOTE:**

Part 3 use only for camo A, D.  
All fittings and the control stick were  
in dark metal colour.

Díl 3 použijte jen pro camo A, D.  
Veškerá kování a řídicí  
páka byly v barvě  
tmavého kovu.

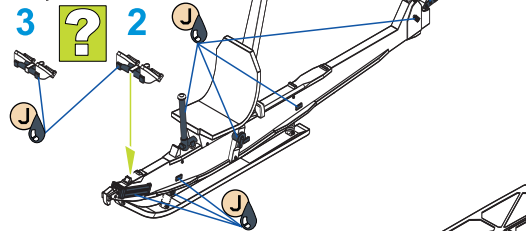
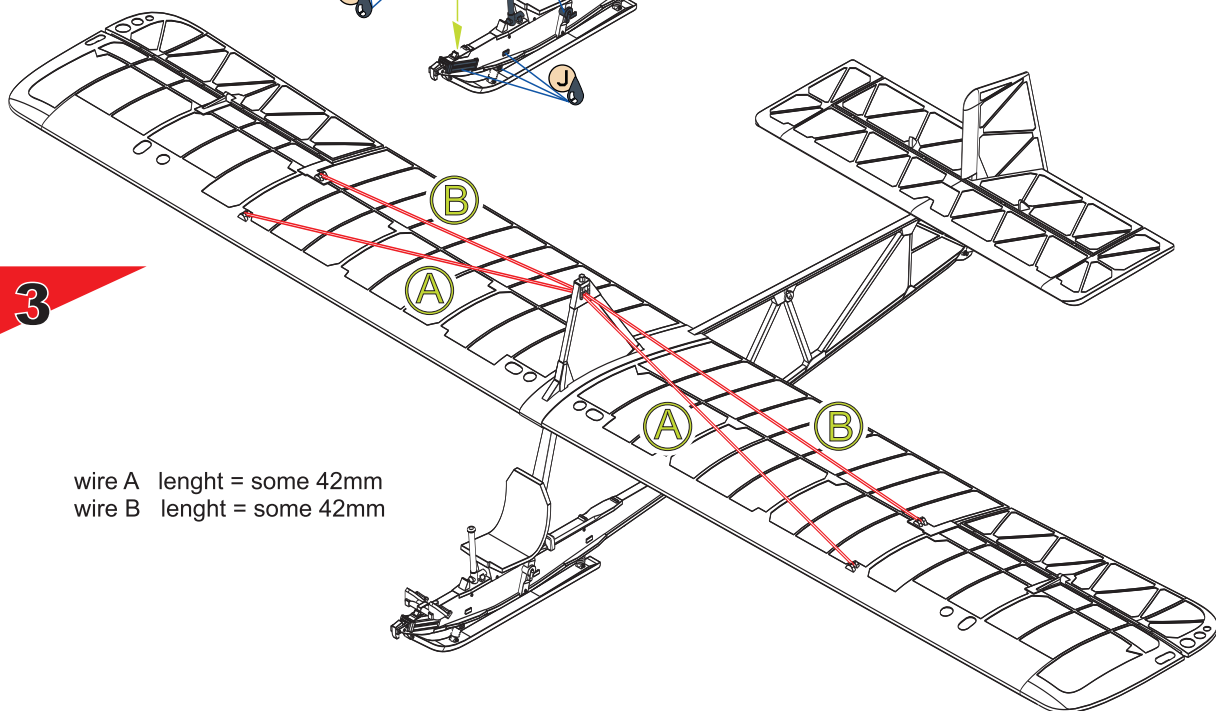
**3**

wire A lenght = some 42mm  
wire B lenght = some 42mm

4

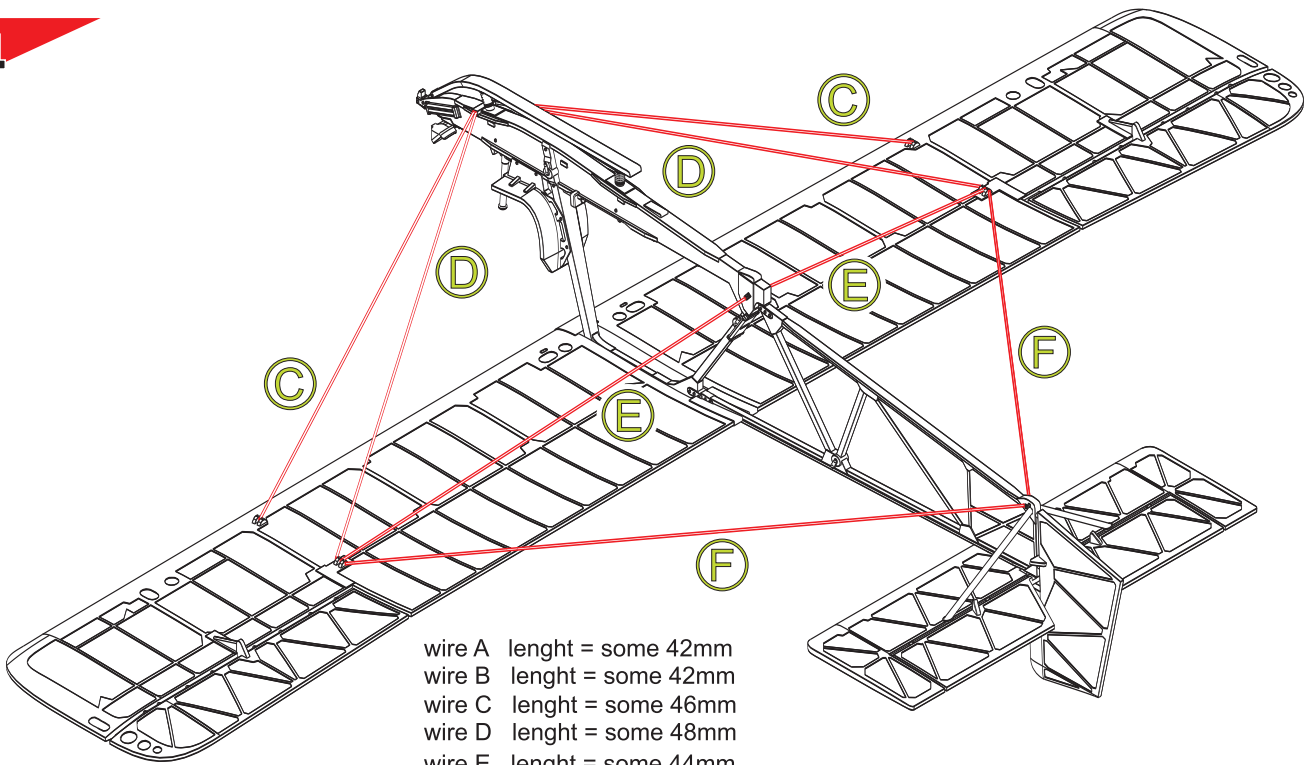

- wire A lenght = some 42mm
- wire B lenght = some 42mm
- wire C lenght = some 46mm
- wire D lenght = some 48mm
- wire E lenght = some 44mm
- wire F lenght = some 61mm

5

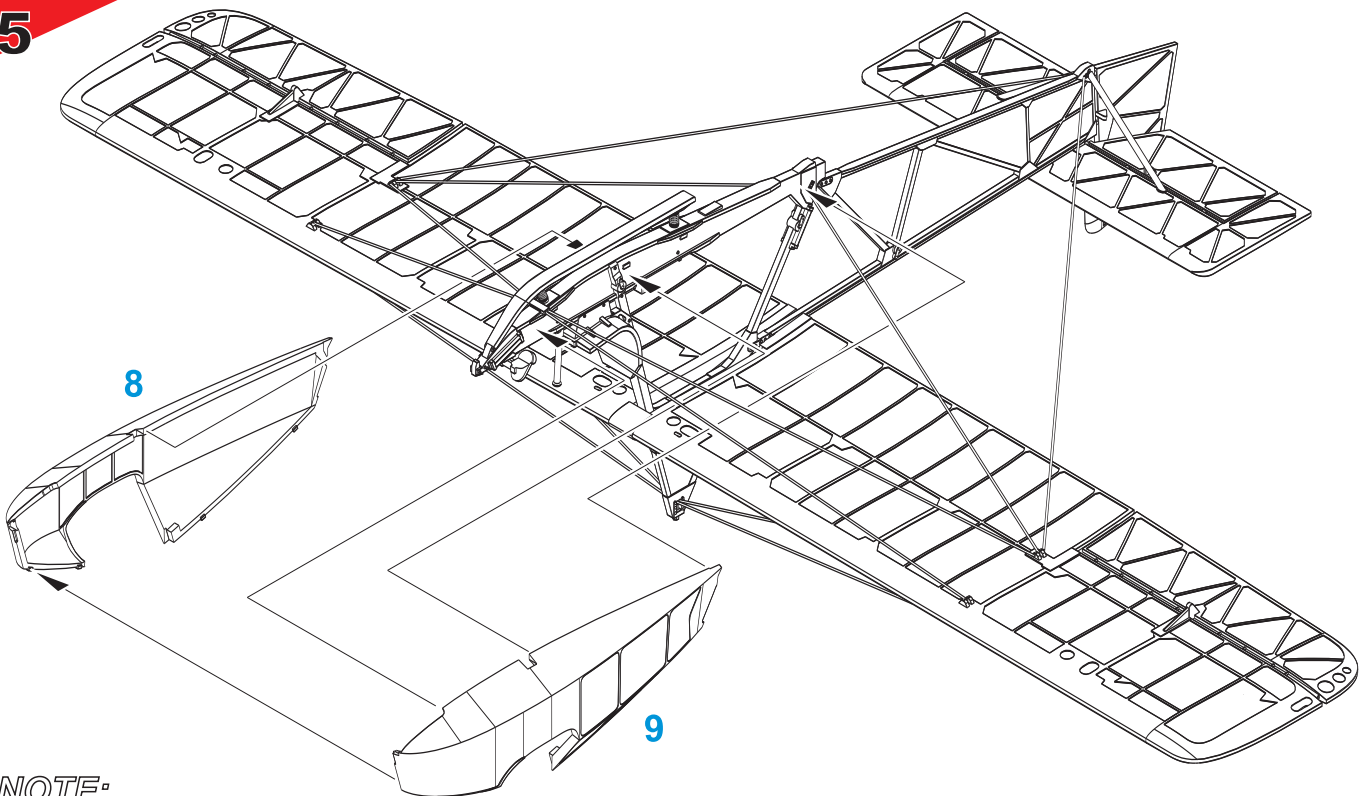

**NOTE:**

Parts 8 and 9 use only for camo A, D.  
Díly 8 a 9 použijte jen pro camo A, D.

**INFO VIEW:**

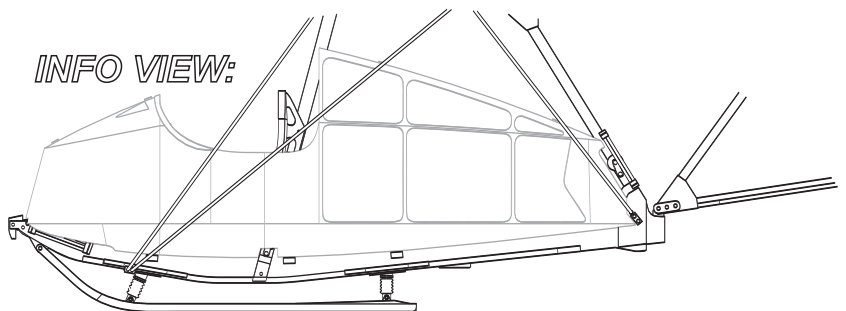

Eon Eton TX.1, WP270, c/n 038, delivered to Maidstone Grammar School Combined Cadet Force (Air Cadets) in September 1951 where it was used until May 1961 and had accumulated 1183 launches. Its last flight took place on 12 July 1962 at RAF Bicester, since then on display at Hendon and Manchester museums.

Eon Eton TX.1, WP270, výrobní číslo 038, byl používán od září 1951 v Maidstone Grammar School Combined Cadet Force (Air Cadets). Bylo na něm provedeno 1183 letů, poslední 12. července 1962. Nyní je muzejním exponátem.

CAM. A

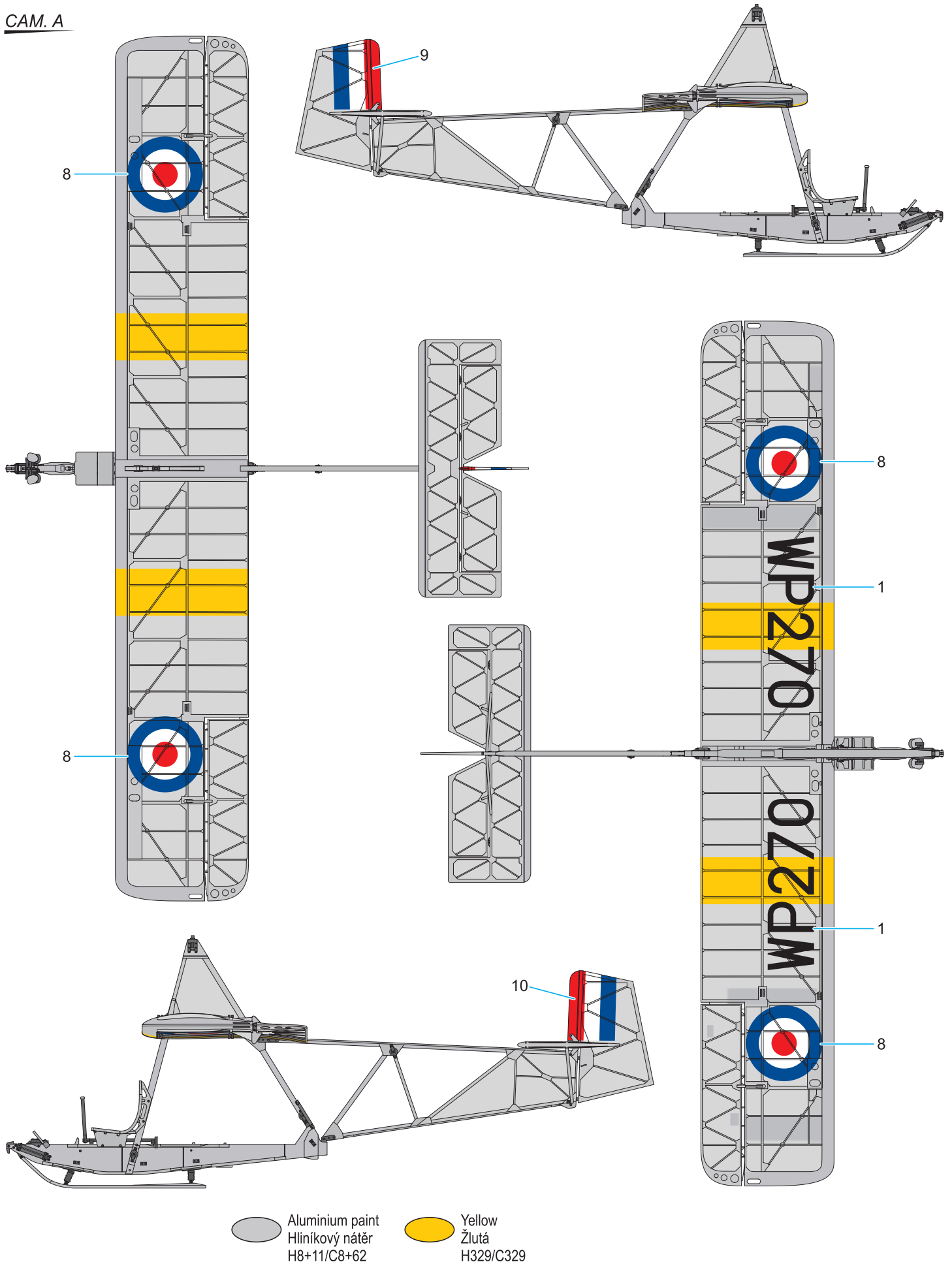

Eon Eton TX.1, WP265, c/n 033, operated by Air Cadets at RAF West Malling in the 1950s.

Eon Eton TX.1, WP265, výrobní číslo 033, používali Air Cadets na základně RAF West Malling v padesátých letech minulého století.



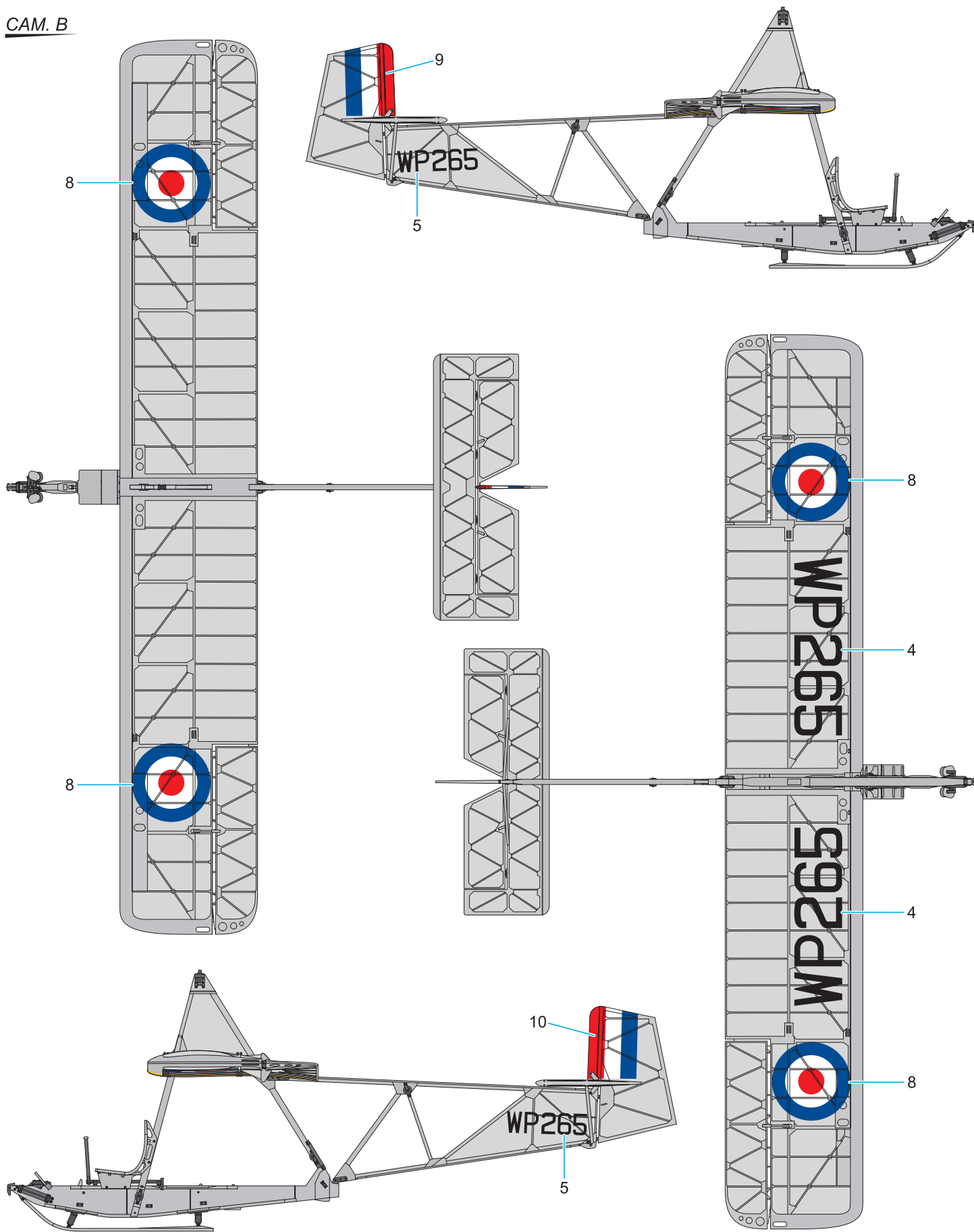

CAM. B

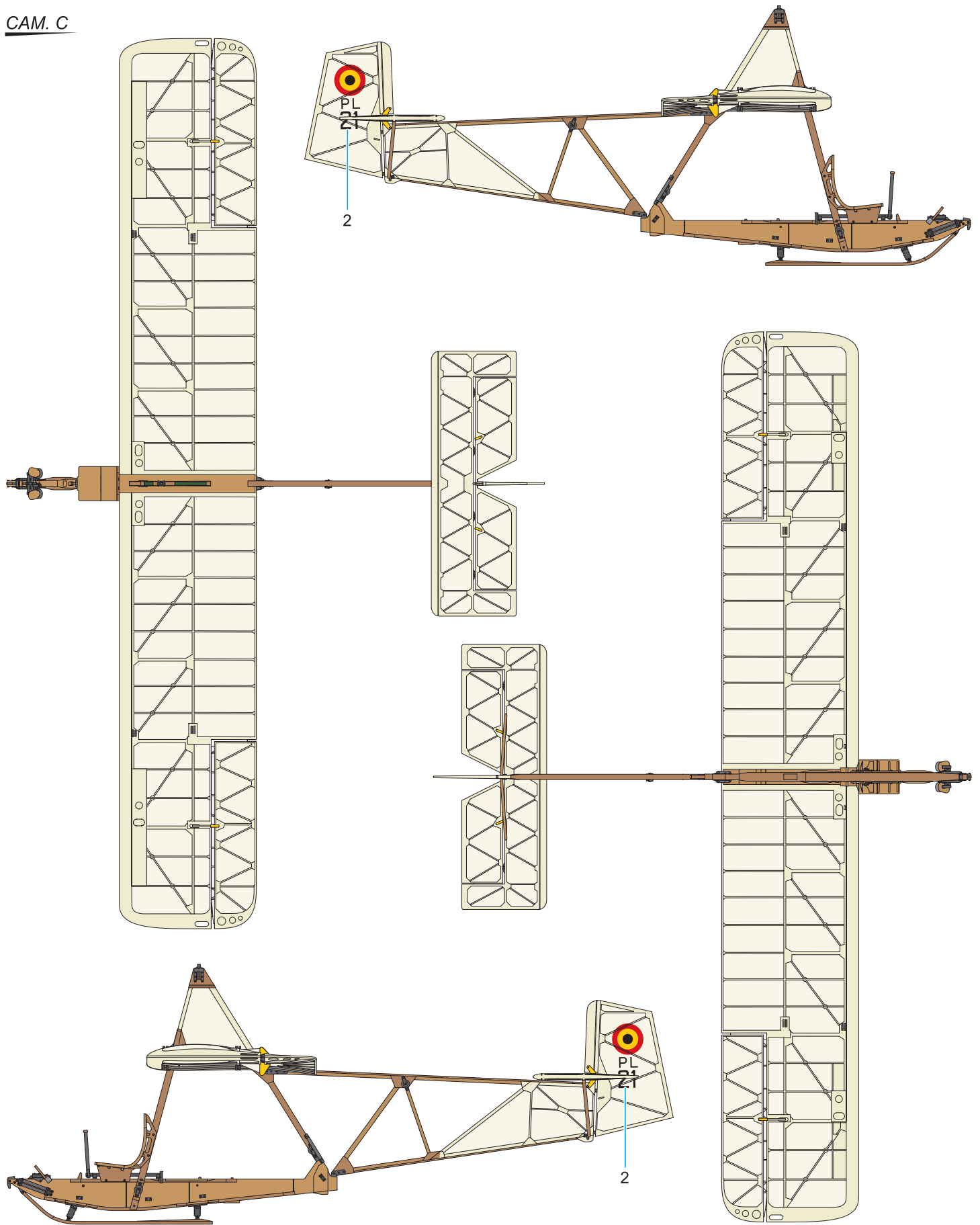

○ Aluminium paint  
Hliníkový nátěr  
H8+11/C8+62

CAM. C



- |                                                                                     |                                              |                                                                                     |                                            |                                                                                     |                                                                                                |                                                                                      |                              |
|-------------------------------------------------------------------------------------|----------------------------------------------|-------------------------------------------------------------------------------------|--------------------------------------------|-------------------------------------------------------------------------------------|------------------------------------------------------------------------------------------------|--------------------------------------------------------------------------------------|------------------------------|
|  | Varnished Wood<br>Lakované dřevo<br>H66/C119 |  | Bleaded fabric<br>Bělené plátno<br>H21/C69 |  | Fabric over the wood construction<br>Plátno přes dřevěnou konstrukci<br>H21+(5%H85)/C69(5%C45) |  | Yellow<br>Žlutá<br>H329/C329 |
|-------------------------------------------------------------------------------------|----------------------------------------------|-------------------------------------------------------------------------------------|--------------------------------------------|-------------------------------------------------------------------------------------|------------------------------------------------------------------------------------------------|--------------------------------------------------------------------------------------|------------------------------|

CAM. D

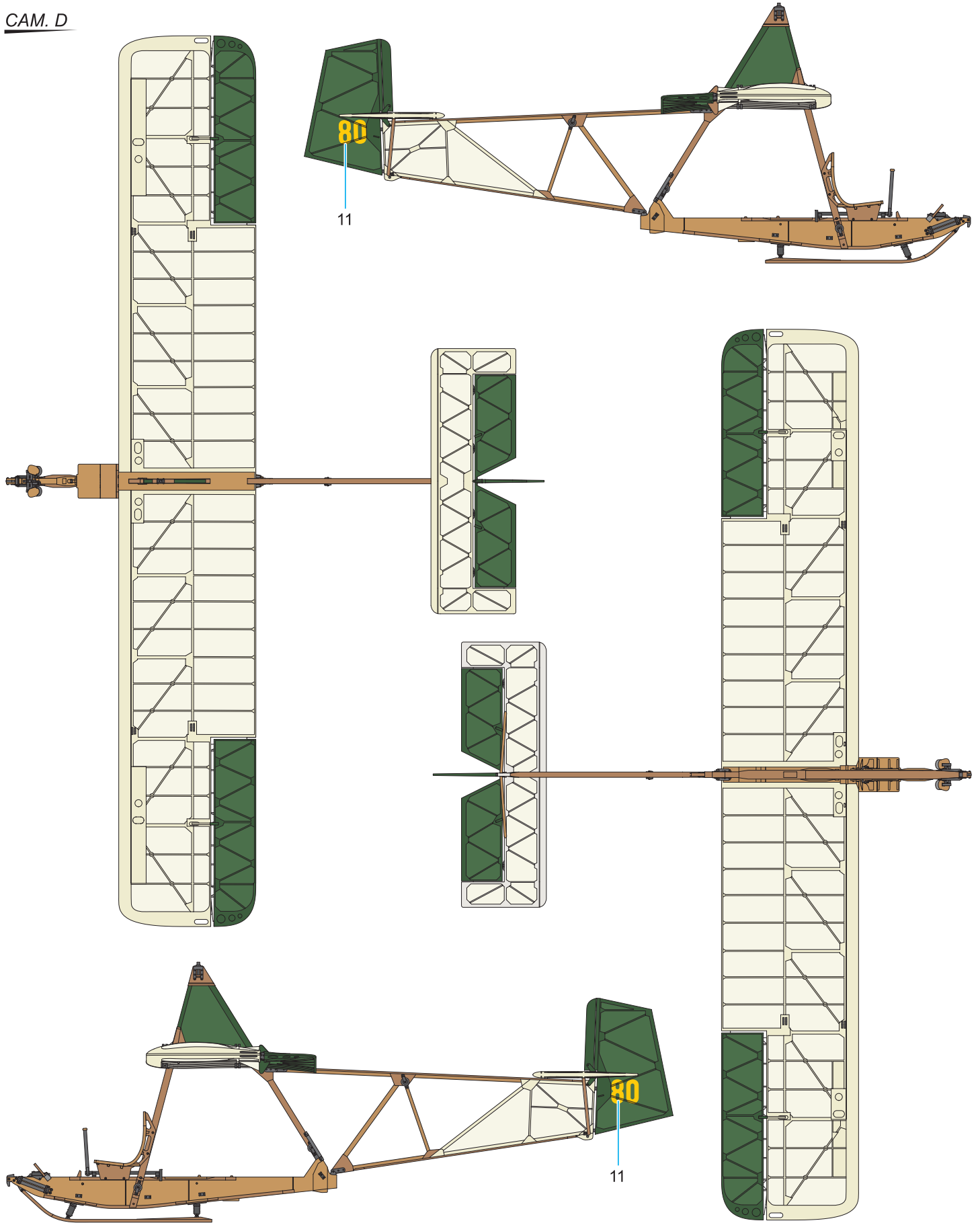

- |                                                                                     |                                              |                                                                                     |                                            |                                                                                     |                                                                                                |                                                                                      |                                       |
|-------------------------------------------------------------------------------------|----------------------------------------------|-------------------------------------------------------------------------------------|--------------------------------------------|-------------------------------------------------------------------------------------|------------------------------------------------------------------------------------------------|--------------------------------------------------------------------------------------|---------------------------------------|
|  | Varnished Wood<br>Lakované dřevo<br>H66/C119 |  | Bleaded fabric<br>Bělené plátno<br>H21/C69 |  | Fabric over the wood construction<br>Plátno přes dřevěnou konstrukci<br>H21+(5%H85)/C69(5%C45) |  | Dark Green<br>Tmavě zelená<br>H73/C70 |
|-------------------------------------------------------------------------------------|----------------------------------------------|-------------------------------------------------------------------------------------|--------------------------------------------|-------------------------------------------------------------------------------------|------------------------------------------------------------------------------------------------|--------------------------------------------------------------------------------------|---------------------------------------|



SG-38, No.95 "Le Timide", France 1945. An original, German-built glider, after the liberation of France used by French sport pilots.

SG-38, No.95 „Le Timide“, Francie 1945. Původně německý kluzák byl po osvobození Francie používán francouzskými sportovními piloty.

CAM. E

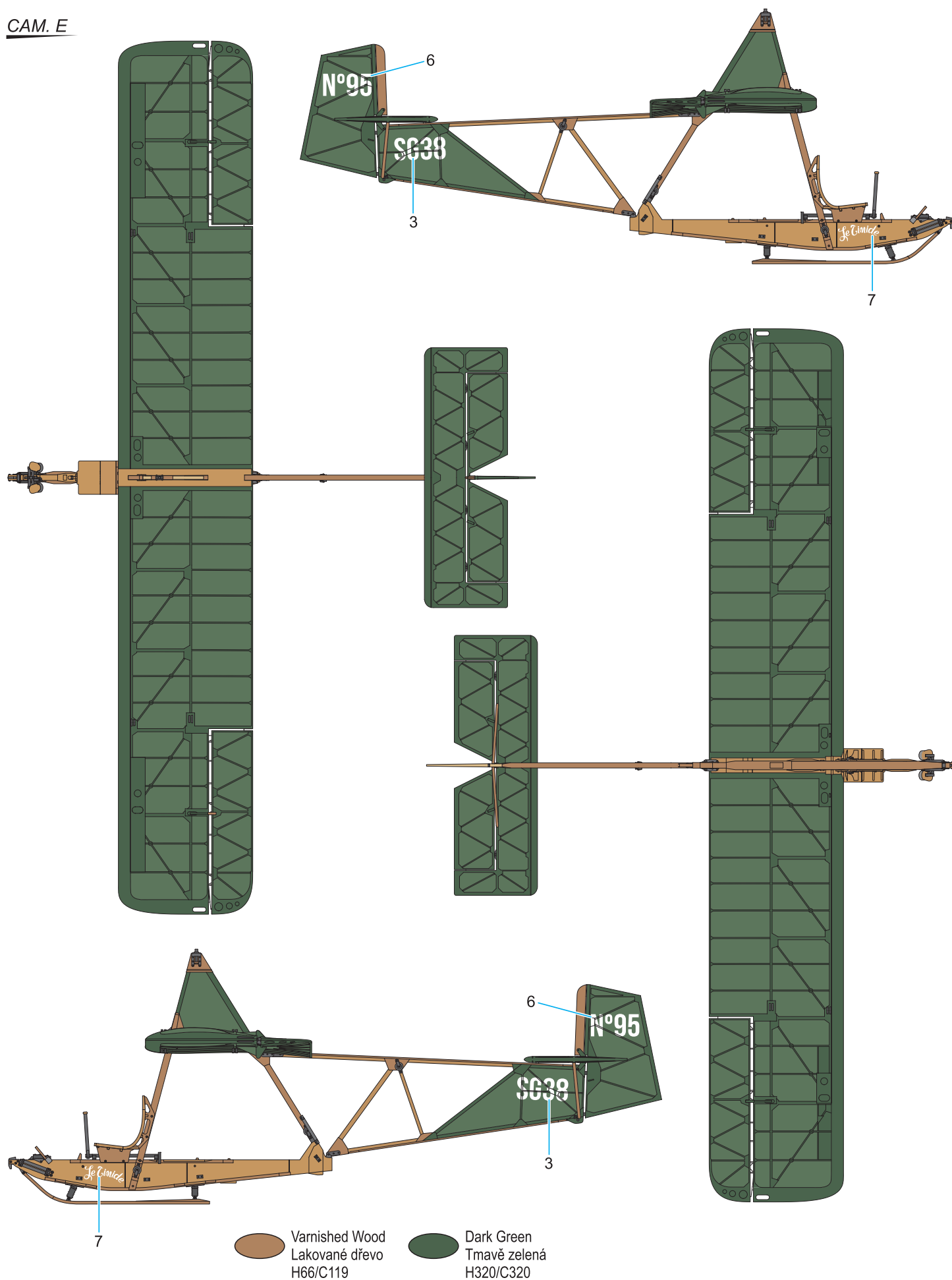

Varnished Wood  
Lakované dřevo  
H66/C119

Dark Green  
Tmavě zelená  
H320/C320

# ATTRACTIVE 1/72 SCALE MODELS



**SH72358**

**A.W. Meteor NF MK.11**



**SH72360**

**A.W. Meteor NF MK.12**



**SH72424**

**Gloster Meteor F.8 Prone Pilot**



1/72  
SH72439

# Messerschmitt Bf 109E-4

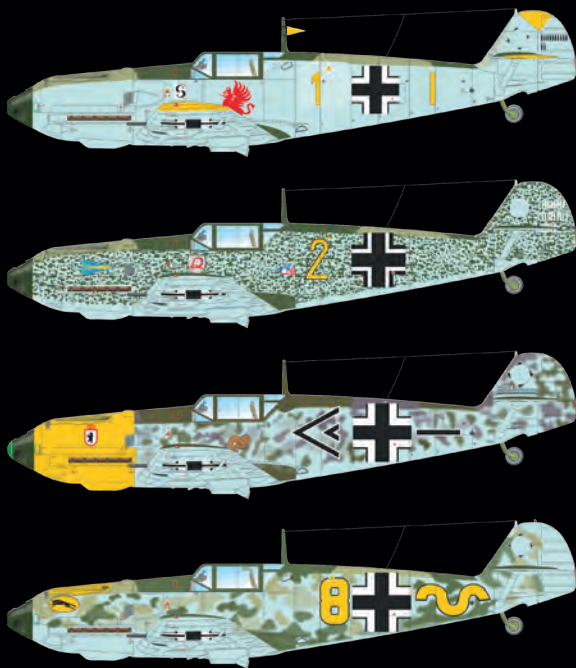

**K72031**  
German Ace Helmut Wick's Bf 109E-4 Decals



M72009 Bf 109E-4

**Special MASK**

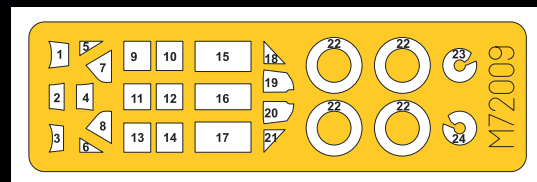

## CMK RESIN SETS

TO MAKE YOUR EMIL EVEN MORE LIFE-LIKE



- 129-7455 Messerschmitt Bf 109E Engine
- 129-7456 Messerschmitt Bf 109E Fuselage Machine Guns and Ammo Boxes
- 129-7457 Messerschmitt Bf 109E Wing Guns
- 129-7458 Messerschmitt Bf 109E FuG VII Radio Equipment
- 129-7459 Bomb trolley for Bf 109E-4/B and other planes
- 129-7460 Messerschmitt Bf 109E-1/5/8 Wing Machine Guns
- 129-Q72384 Messerschmitt Bf 109E Wheels
- 129-Q72385 Messerschmitt Bf 109E-4/B SC500 Bomb and Rack
- 129-Q72389 Messerschmitt Bf 109E Propeller Hub and Spinner Detail Set
- 129-F72369 Bf 109E Ace A. Galland and Mechanic
- 129-Q72390 Messerschmitt Bf 109E Exhausts and more...

**Special HOBBY**

[facebook.com/specialhobby](https://www.facebook.com/specialhobby)  
[WWW.SPECIALHOBBY.EU](http://WWW.SPECIALHOBBY.EU) | [WWW.CMKKITS.COM](http://WWW.CMKKITS.COM)

**CMK**  
CZECH MASTER'S KITS

1/72  
SH72418



# SIAI Marchetti SF-260M/AM/W

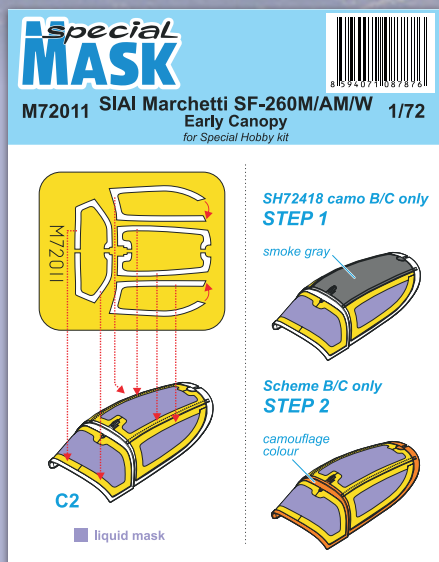

**Use  
this!**



**Star Dust**  
weathering pigments



**The Razor Saw with Handle (cat. n. H1010) is a great tool for cutting both plastic and resin. CMK also offers a wide variety of coarse/medium/fine saws.**

**H1000** Ultra smooth and extra smooth saw (2 sides – 70 teeth / 42 teeth) 1 pc  
**H1001** Ultra smooth saw (both sides – 70 teeth / 70 teeth) 1 pc  
**H1002** Very smooth saw (both sides – 42 teeth / 42 teeth) 1 pc

**H1003** Smooth saw (both sides – 31 teeth / 31 teeth) 1 pc  
**H1004** Ultra smooth and extra smooth saw (2 sides – 70 teeth / 42 teeth) 5 pcs  
**H1005** Ultra smooth saw (both sides – 70 teeth / 70 teeth) 5 pcs

**H1006** Very smooth saw (both sides – 42 teeth / 42 teeth) 5 pcs  
**H1007** Smooth saw (both sides – 31 teeth / 31 teeth) 5 pcs  
**H1010** Razor Saw with Handle

**Special  
HOBBY**

facebook.com/specialhobby  
**WWW.SPECIALHOBBY.EU | WWW.CMKKITS.COM**

**CMK**  
 CZECH  
 MASTER'S KITS