



## SIAI-Marchetti SF-260 M/AM/D/W Duo Pack

Instructions / Návod

EN

The design of an all metal low wing, trainer and light ground attack monoplane was originally prepared by constructor Stelio Frati for the Aviamilano company. The F.250 prototype first took to air in 1964 but crashed soon after. The slightly improved version, bearing designation changed to F.260 was taken aloft for the first time on 15 July 1964. The production rights were bought by SIAI Marchetti not long after and the production machines were known as the SF.260. Although some of the machines were used by civil operators, the majority of built SF.260s were sold to various air forces. The first of the military versions, the SF-260M found its way to the Italian Air Force (SF-260AM) as well as to Belgium and Libya (SF-260ML), and later to even more military operators worldwide. Among the other versions to have enjoyed rather widespread service was the SF-260W Warrior which was fitted with wing hardpoints enabling it to carry variety of armament and fly in the COIN (Counter-Insurgency) role. The major operator of this version became, again, Libya, but other air forces bought the Warrior as well, such as those of Ireland, Indonesia, Singapore, Bolivia and others. During the years, the SF-260C, D and E improved version were offered for the use by both civil and military subjects. The very final version of the type to be fitted with the Lycoming O-540 piston powerplant was the SF-260EA built for the Aeronautica Militare.

From 1980 on, a turboprop-fitted SF-260TP was also produced, having the Allison 250 unit in the nose. This version, too, was well liked among small air forces. The main operators of this type were the military of the Philippines (where the older, piston engined versions had been re-built to the turboprop standard), Burundi, Zambia and Haiti.

Civil versions of the SF-260 keep flying around the globe still, because of their excellent aerobatics performance they have been used by aerobatics teams or by airlines' flying schools, such as those owned by Sabena, Alitalia or even the Air Combat USA, a civil school using the type to train military pilots.

Span: 8.35m, length: 7.1m, top speed: 333km/h, range: 1,650km, ceiling: 4,665m, rate of climb: 7.6m/s.

CZ

Návrh celokovového dolnoplošného jednoplošníku s určením pro výcvik nebo jako lehký bojový letoun vypracoval konstruktér Stelio Frati původně pro firmu Aviamilano. Prototyp označený F.250, zalétaný v roce 1964 záhy havaroval. Upravená verze, přeznačená na F.260 vzletla poprvé 15. července 1964. Nedlouho poté zakoupila práva k výrobě firma SIAI Marchetti a sériové stroje dostaly označení SF.260. I když se SF.260 prodával i civilním uživatelům, hlavními odběrateli byla vojenská letectva. První produkční vojenská verze SF.260M byla dodána Italskému (SF.260AM), Belgickému a Libyjskému letectvu (SF.260ML). Postupně byla dodávána i dalším vojenským uživatelům po celém světě. Další sériově vyráběnou a velmi rozšířenou verzí se stala verze SF.260W Warrior. Ta byla vybavena křídlem se závěsníky a byla používána mnoha menšími letectvy jako letoun kategorie COIN. Největším odběratelem se stala opět Libye, letouny ale používají nebo používaly Irsko, Indonésie, Singapur, Bolívie a další státy. Civilním i vojenským zákazníkům byly v průběhu let nabídnuty vylepšené verze SF.260C, D a E. Poslední vyráběnou verzí s pístovým motorem Lycoming O-540 se stala SF.260EA, určená pro italské letectvo.

Od roku 1980 byla vyráběna i verze s turbovrtulovým motorem SF.260TP. V předí této verze je montován turboprop Allison 250. I tato verze byla a je oblíbená u malých vojenských letectev. Uživatelé této verze jsou nebo byly letectva Filipín (zde byly i pístové stroje přestavovány na turbo verzi), Burundi, Zambie, Haiti a další.

Civilní verze létají po celém světě, pro výborné akrobatické vlastnosti je používají nebo používaly akrobatické skupiny nebo civilní letecké školy velkých aerolinek, jako je Sabena, Alitalia či civilní škola pro výcvik bojových pilotů Air Combat USA.

Rozpětí: 8,35 m, délka: 7,1 m, max. rychlost: 333 km/h, dolet: 1650 km, dostup: 4 665 m, stoupavost: 7,6 m/s.

**A 2x**

**Parts List**

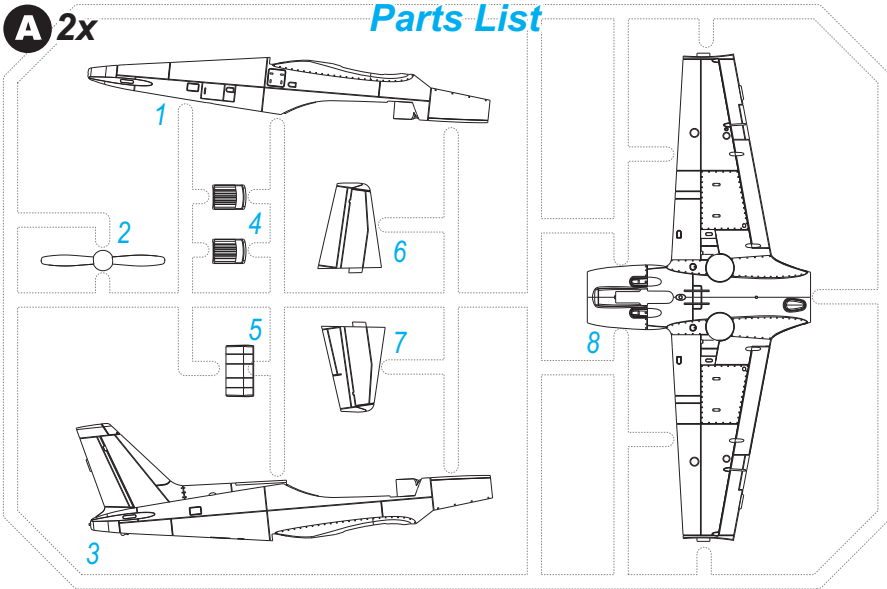

✗ = Not used

**B 2x**

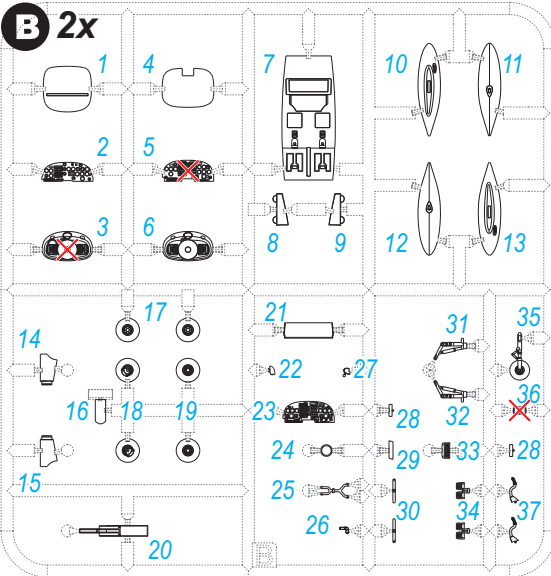

**C 2x**

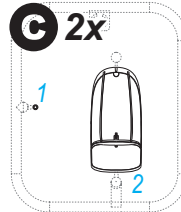

**Clear Parts**

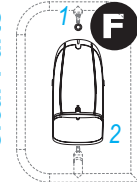

**D 2x**

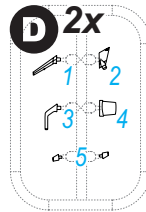

**E 2x**

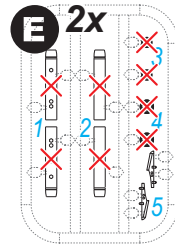

**PUR - Resin Parts**

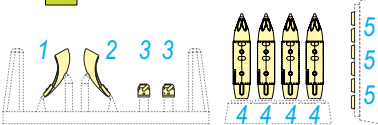

**PE - Photo Etches**

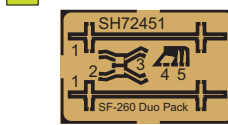

**Barvy GUNZE/ GUNZE Colour No.**

<b>A</b>	Černá / Black	H12/C33
<b>B</b>	Světlá šedá / Light Gray	H51/C11
<b>C</b>	Šedobílá / Off White	H21/C69
<b>D</b>	Hliníková / Aluminium	H1/C8
<b>E</b>	Opálený kov / Burnt Iron	H76/C61
<b>F</b>	Barva pneu / Tire Black	H77/C137
<b>G</b>	Červená čírá / Clear Red	H90/C47
<b>H</b>	Zelená čírá / Clear Green	H94/C138
<b>I</b>	Tmavý kov / Dark Iron	H28/C78



**MŮŽNOST VOLBY  
OPTIONAL  
NACH BELIEBEN  
OPTION**



**POUŽÍT KYANOAKRYLÁTOVÉ LEPIDLO  
INSTANT CYANOACRYLATE GLUE  
ZYANOAKRYLATKLEBER  
ADHÉSIF CYANOACRYLAT**

**SYMBOLS**



**OHNOUT  
BEND  
BIEGEN  
COURBER**



**ZHOTOVIT NOVÉ  
SCRATCH BUILD  
FERTIGSTELLEN  
ACHEVER**



**REZAT/VRTAT  
CUT OFF/DRILL  
ENTFERNEN  
DETACHER**



**NATRÍT  
COLOUR  
FARBEN  
PEINDRE**  
GSI  
colours code

2

SH72451 SF-260 M/AM/D/W Duo Pack

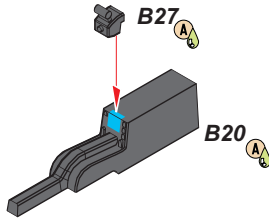
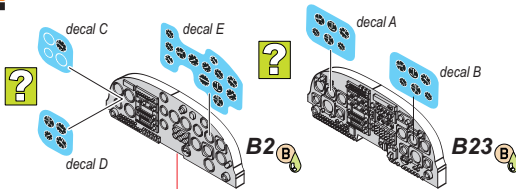
**1****2**

Scheme A: B2 + decals C,E  
 Scheme F: B2 + decals D,E

Schemes B,C,D,E,G,H:  
 B23 + decals A,B

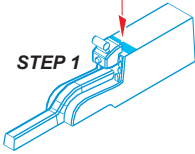
**STEP 1**

Note:  
 interior paint scheme varied,  
 always check your references.

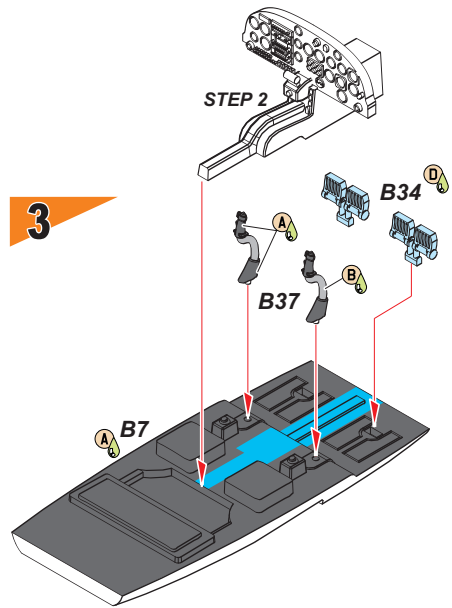
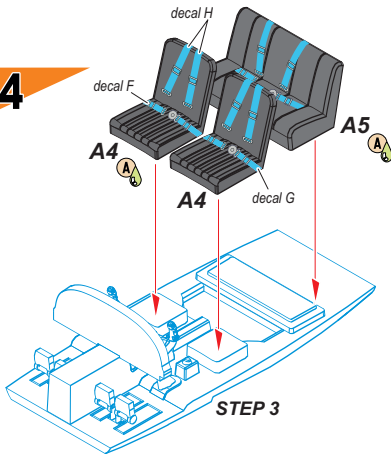
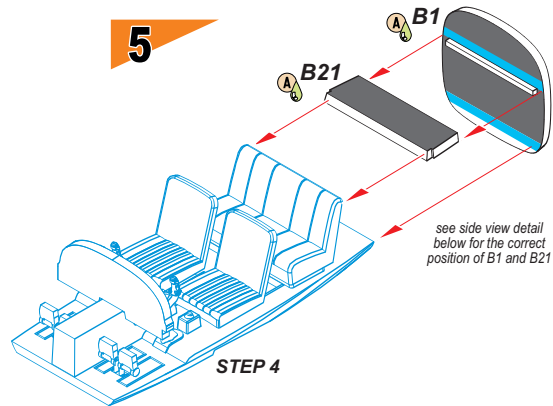
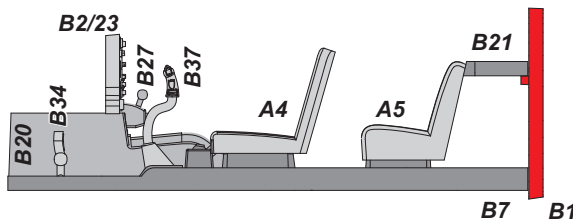
**3****4****STEP 3****5****STEP 4**

6

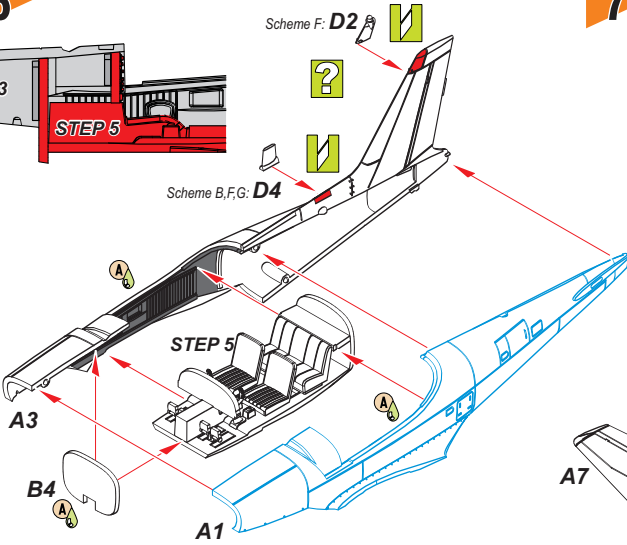

7

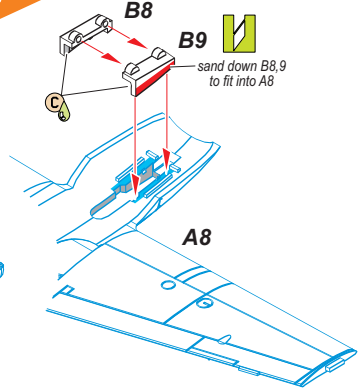

8

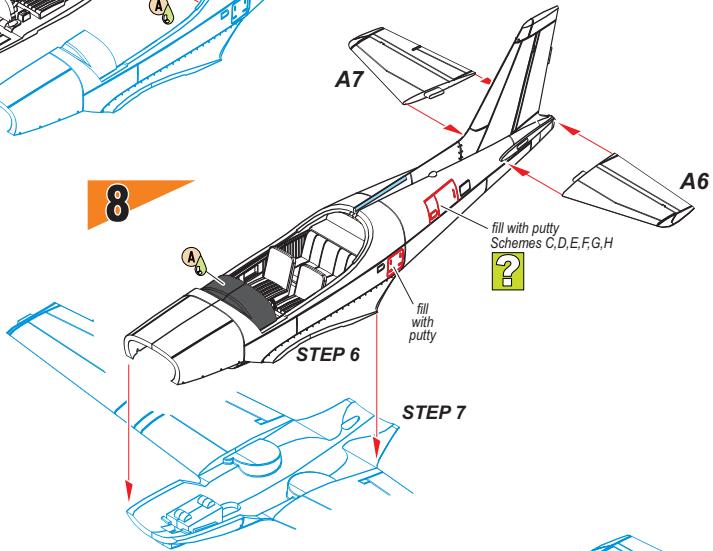

9

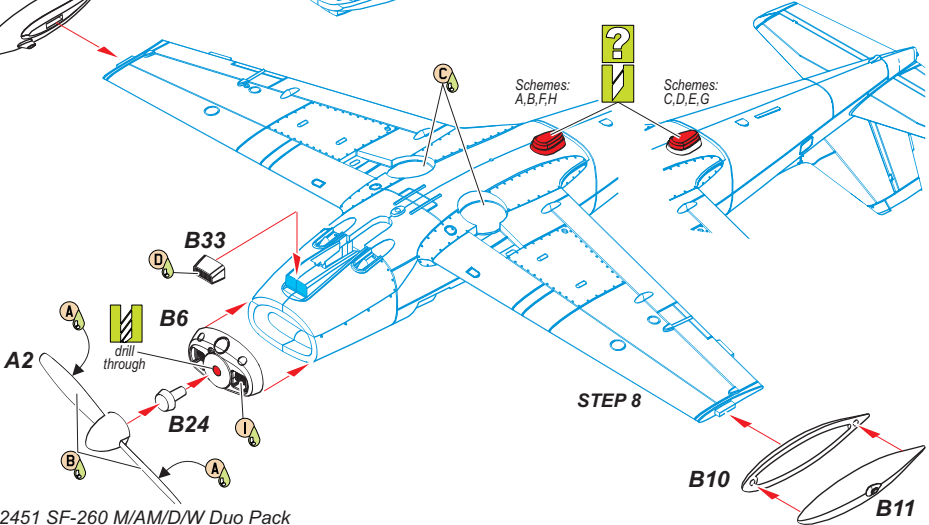

4

# 10

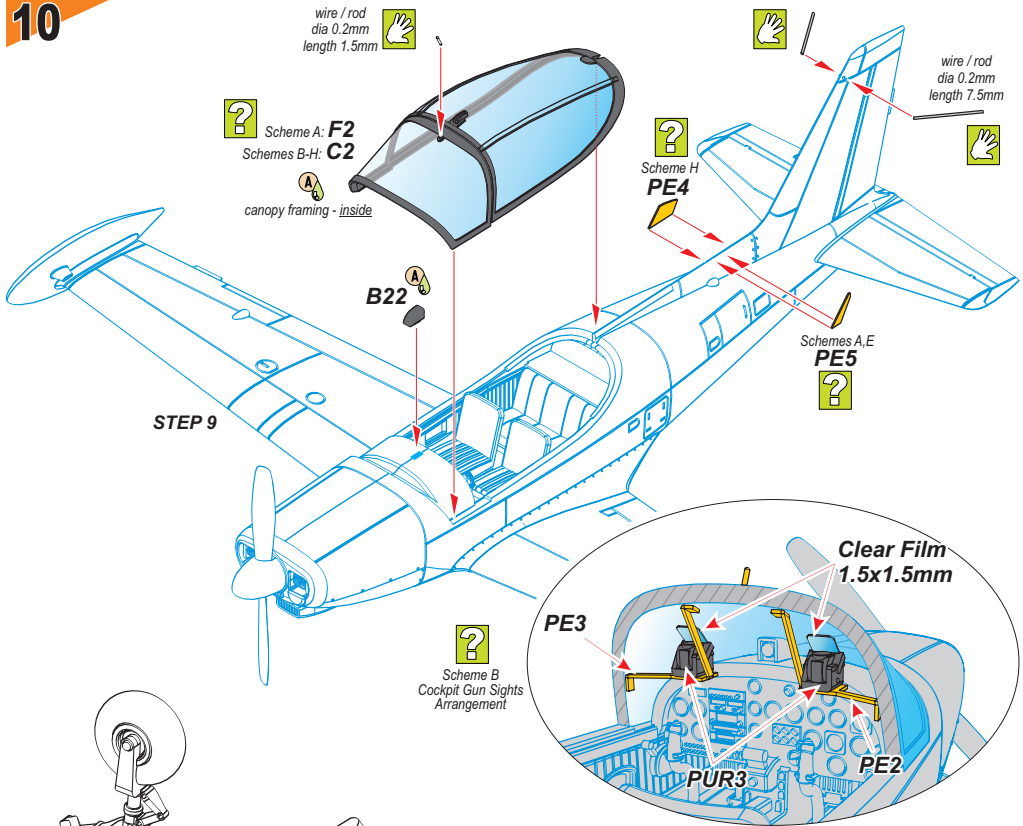

# 11

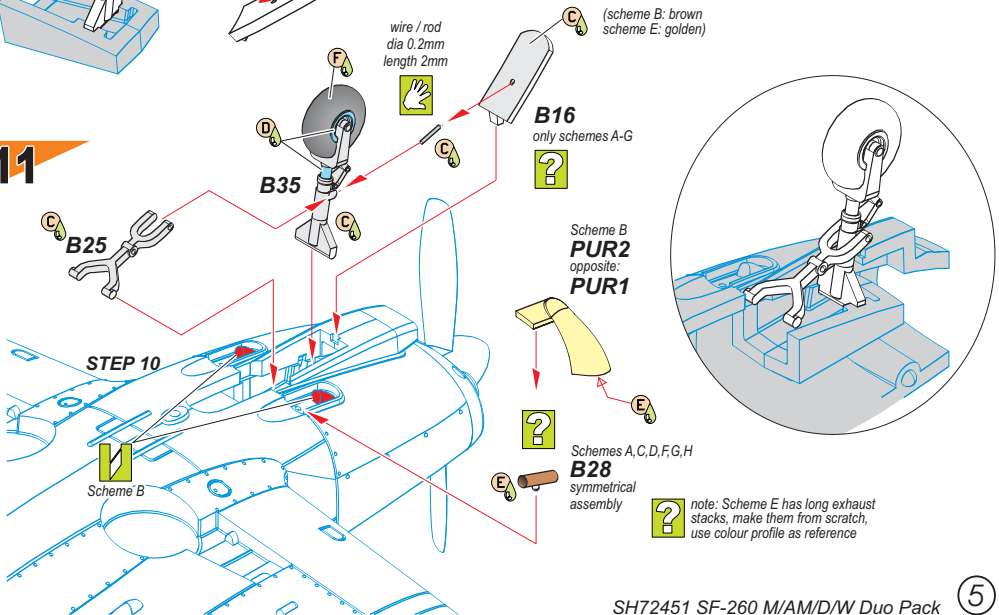

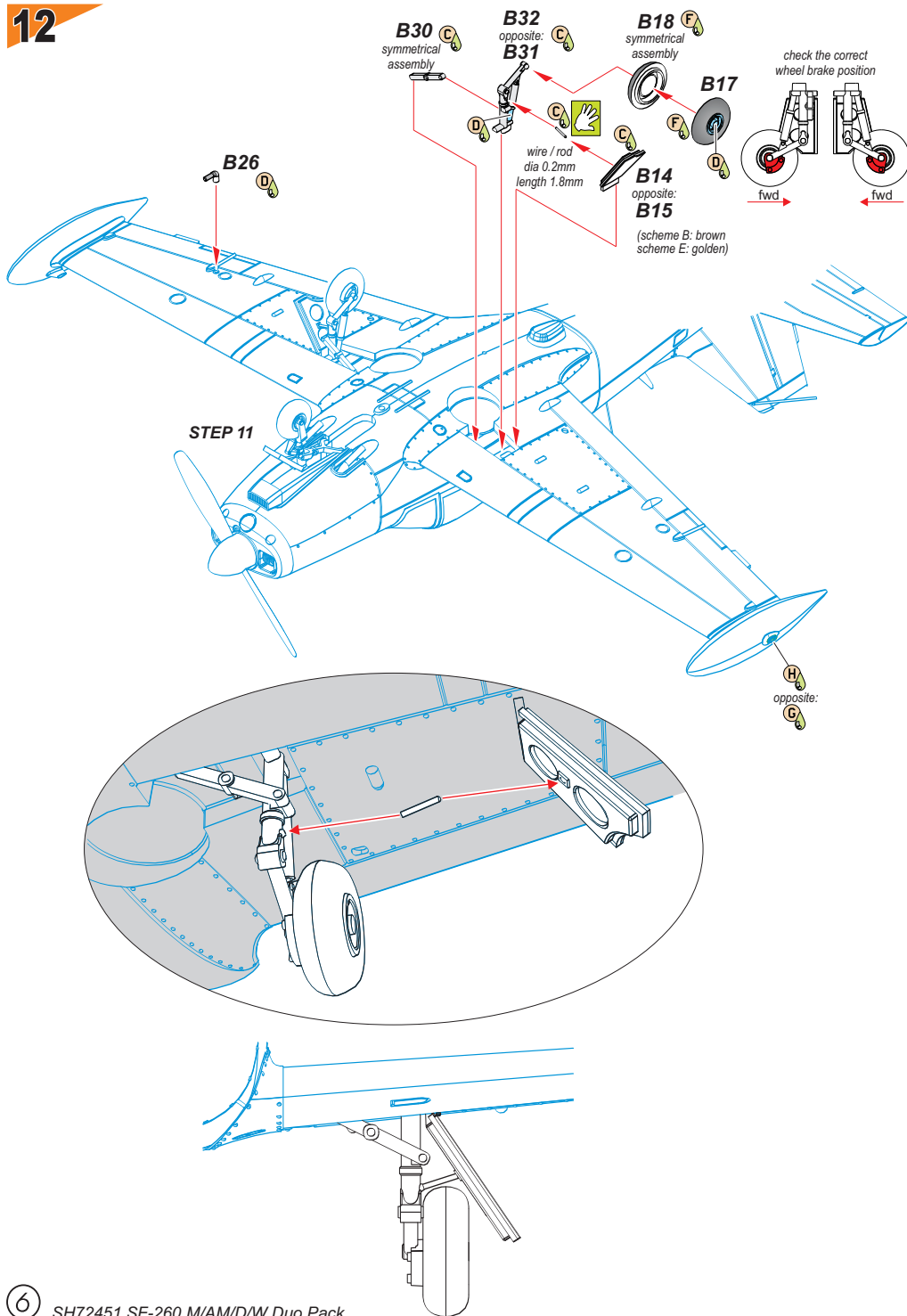

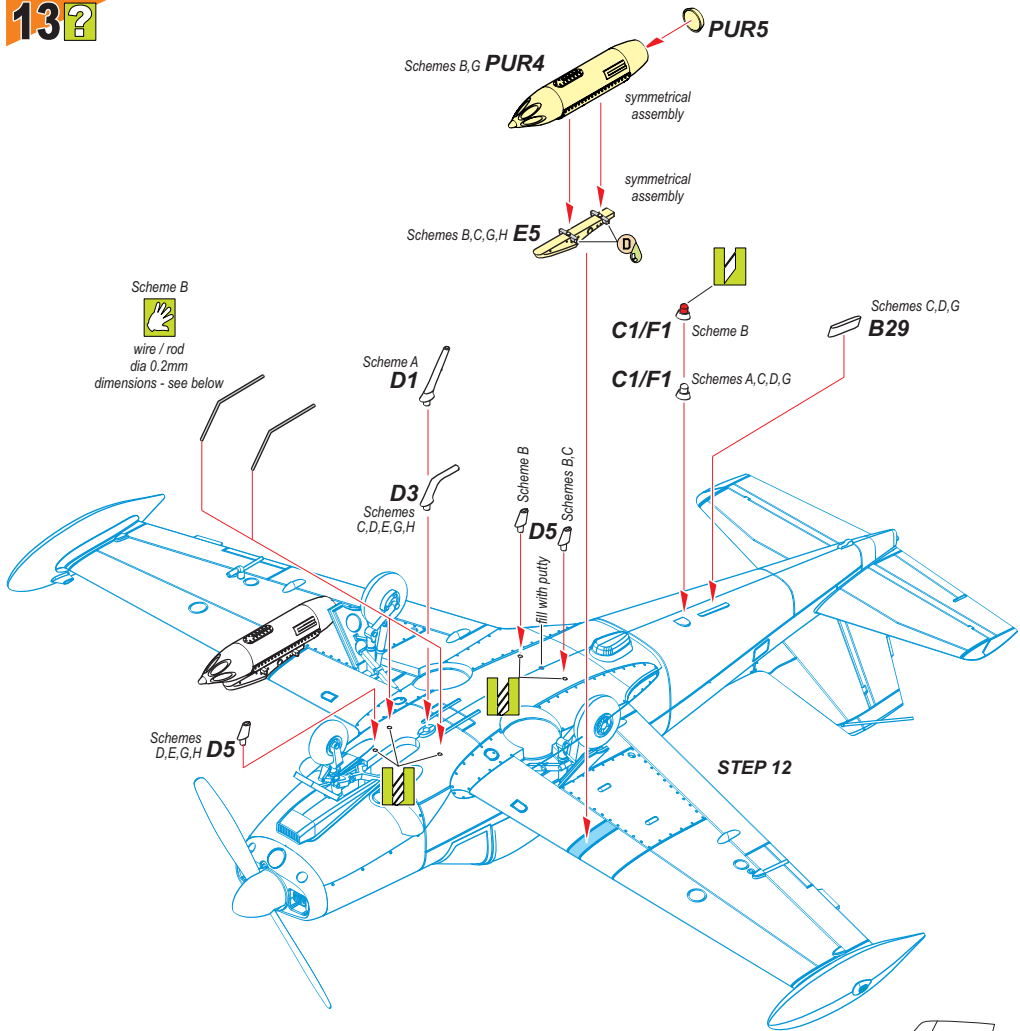

Scheme B  
  
 wire / rod  
 dia 0.2mm  
 dimensions - see below

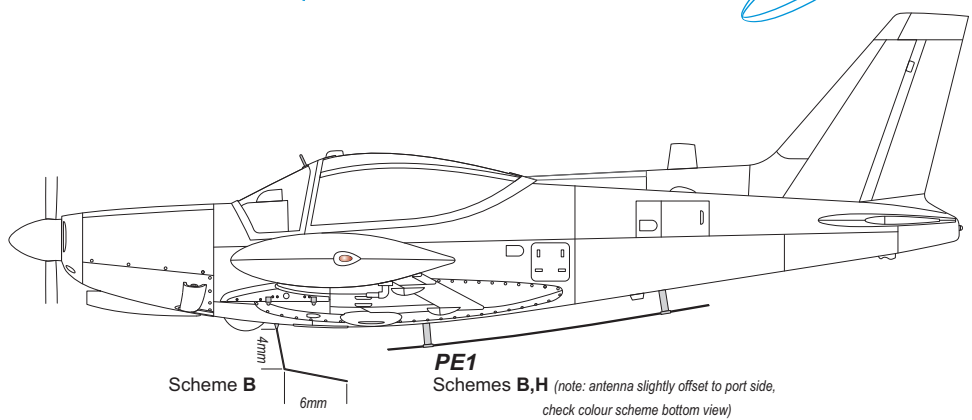

SIAl-Marchetti SF-260M+, ST-34+, Red Devils Aerobatic Display Team, No 5 Squadron, Luchtcomponent/Composante Air (Belgian Air Force), 2015.

SIAl Marchetti SF-260M+, ST-34+, akrobatická a předváděcí skupina Red Devils, no.5 Sqn., belgické letectvo, 2015

Scheme A

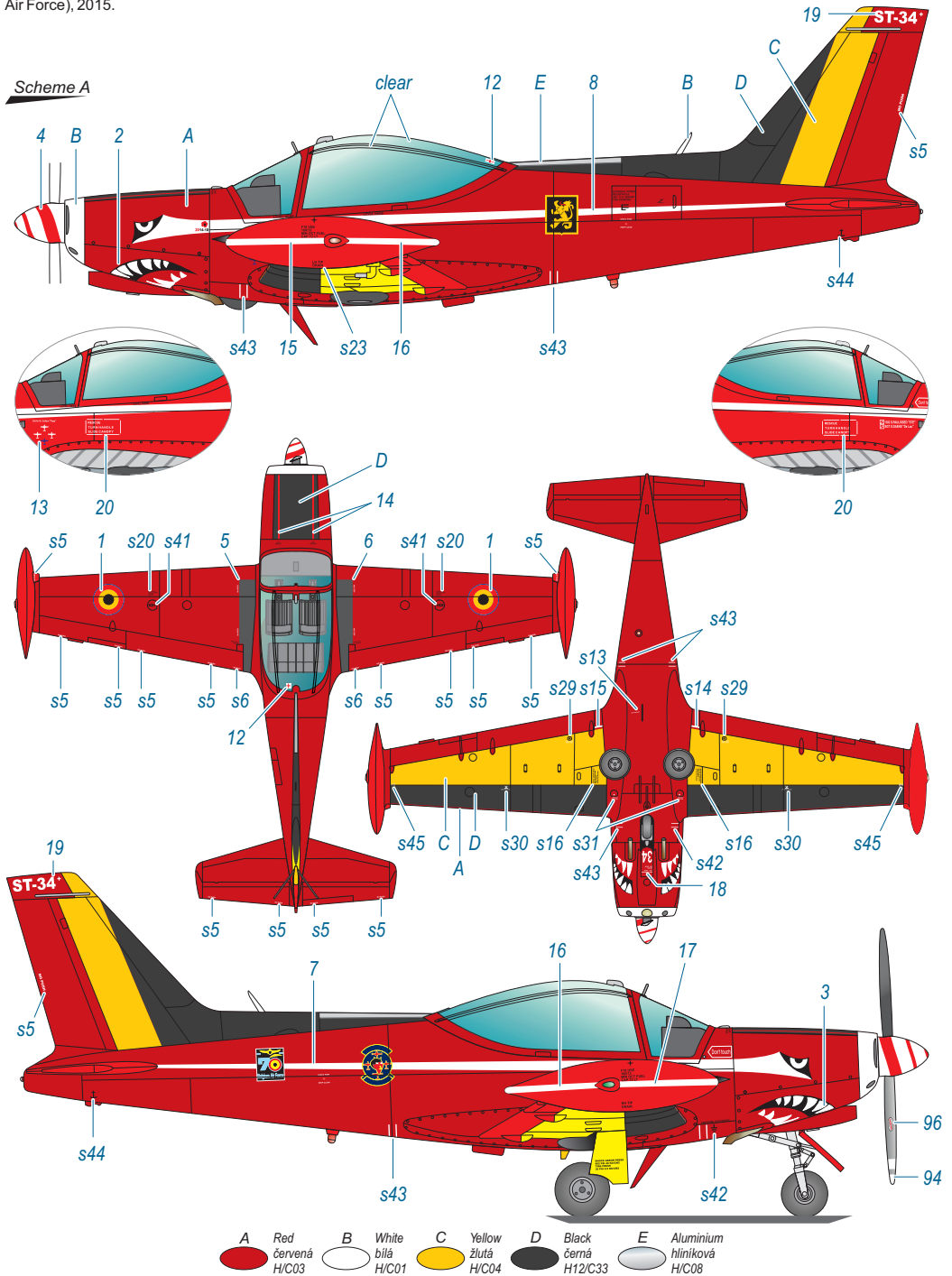



SIAI-Marchetti SF-260 W Genet (Warrior), White S, No.4 Sqn, Rhodesia Air Force, Thornhill, 1978. Rhodesian SF-260s flew wearing a two-tone scheme with either yellow (SF-260Cs) or white trim (SF-260Ws). Machine 'S' had a symbol of a black native warrior on its tail fin. The armed SF-260W airframes flew patrol, recon and escort missions during the so-called 'Rhodesian Bush War'.

SIAI Marchetti SF-260W Genet, bílé S, 4. Sqn rhodeského letectva, základna Thornhill, 1978. Rhodeské SF-260 létaly kamuflované, se žlutými (SF-260C) nebo bílými doplňky (SF-260W). Letoun 'S' nesl na ocasní ploše kresbu domorodého válečníka. Ozbrojené SF-260W byly používány k hlídce, průzkumu a doprovodu vojenských kolon během občanské války známé též jako "The Rhodesian Bush War".

**Scheme B**

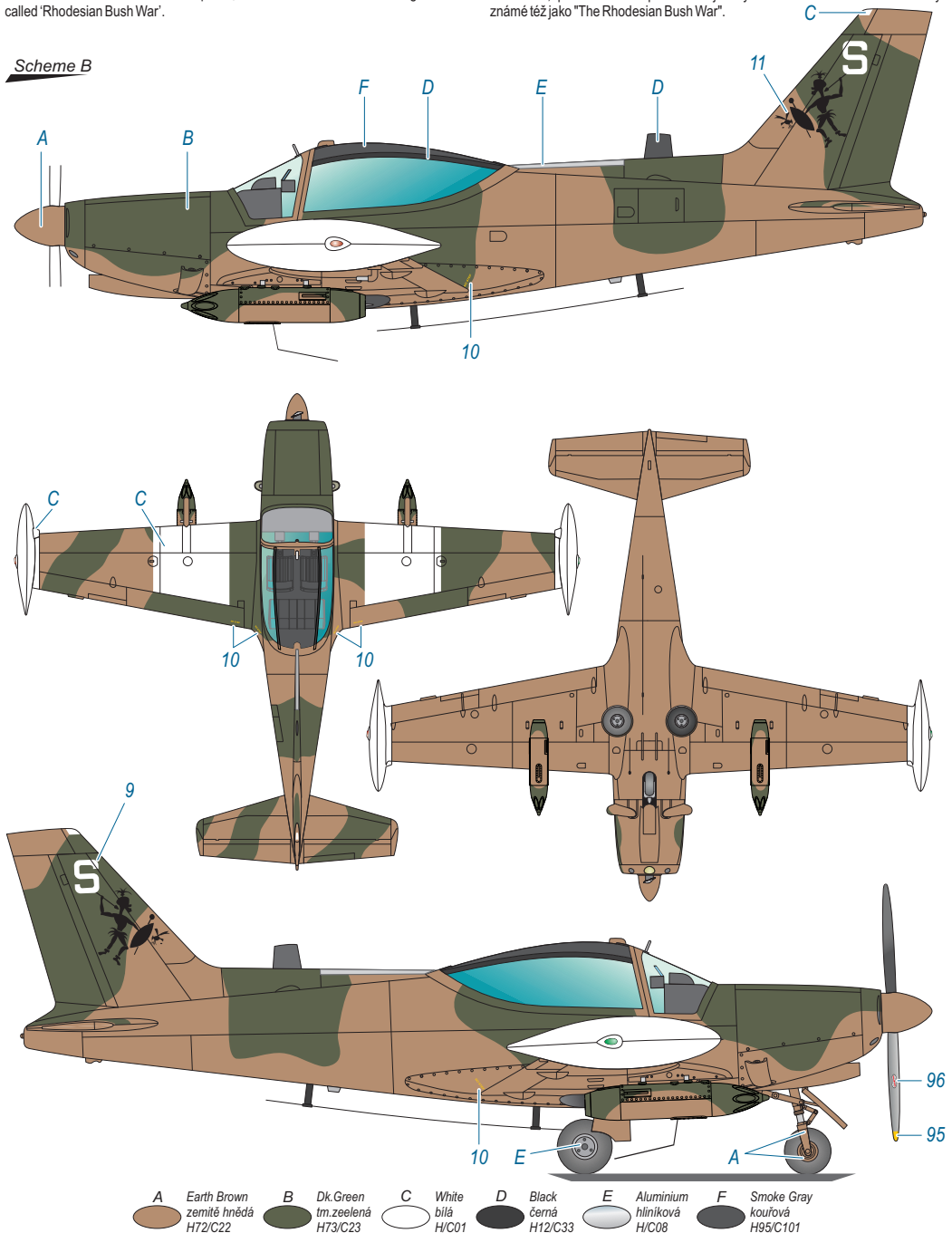

EN: SIAI-Marchetti SF-260 W, FAB-184, Fuerza Aérea Boliviana, 1980. At present times, a privately-owned SF-260 with FAB-184 markings keeps flying over the UK. In actual fact it is a different machine, registered in Britain as G-SIAI (ex Belgian OO-XCP).

SIAI Marchetti SF-260W, FAB-184, bolivijské letectvo, 1980. V současnosti v tomto zbarvení létá soukromý SF-260 ve Velké Británii SF-260. Jde však o jiný letoun s imatrikulací G-SIAI (ex OO-XCP).

**Scheme C**

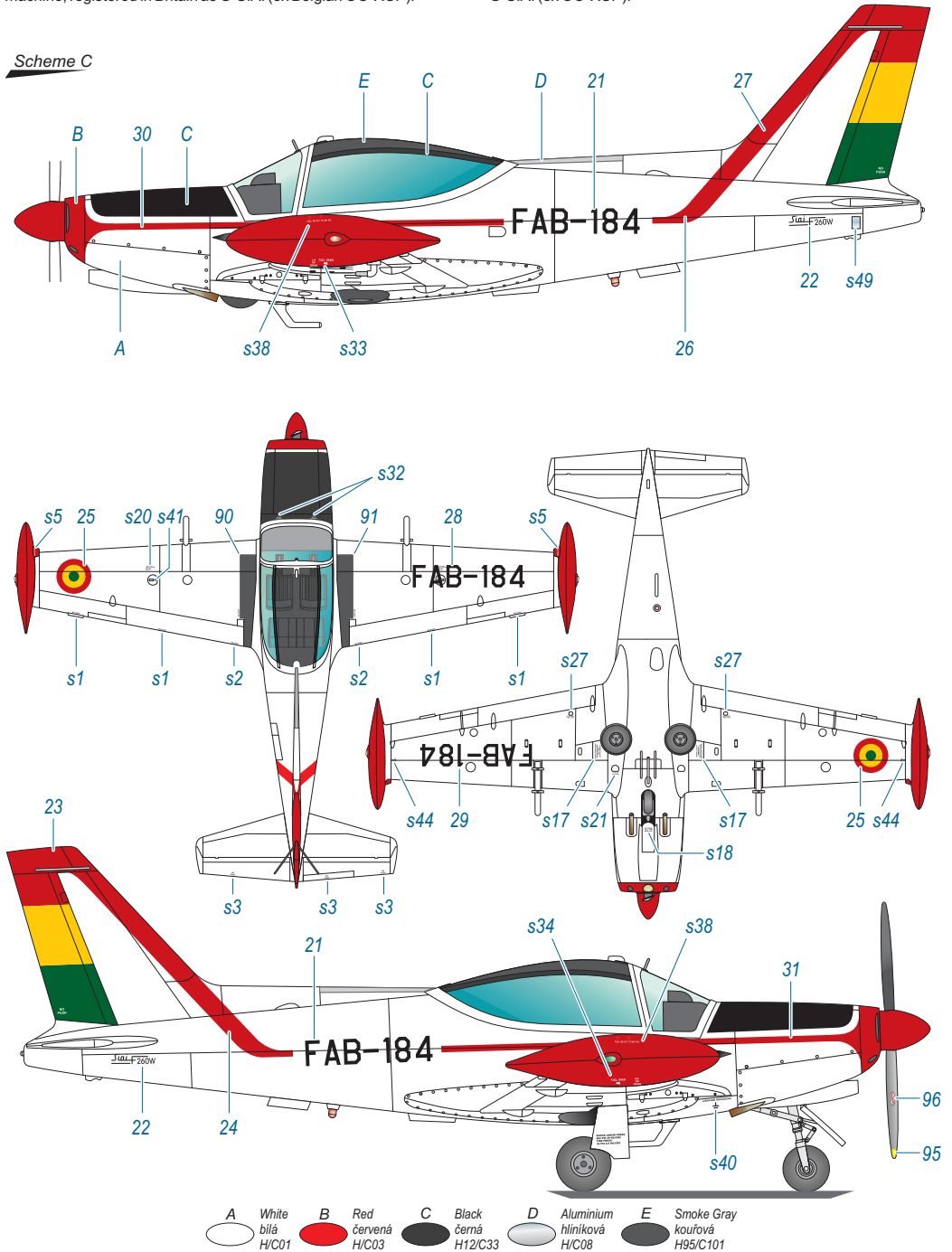

**Scheme D**

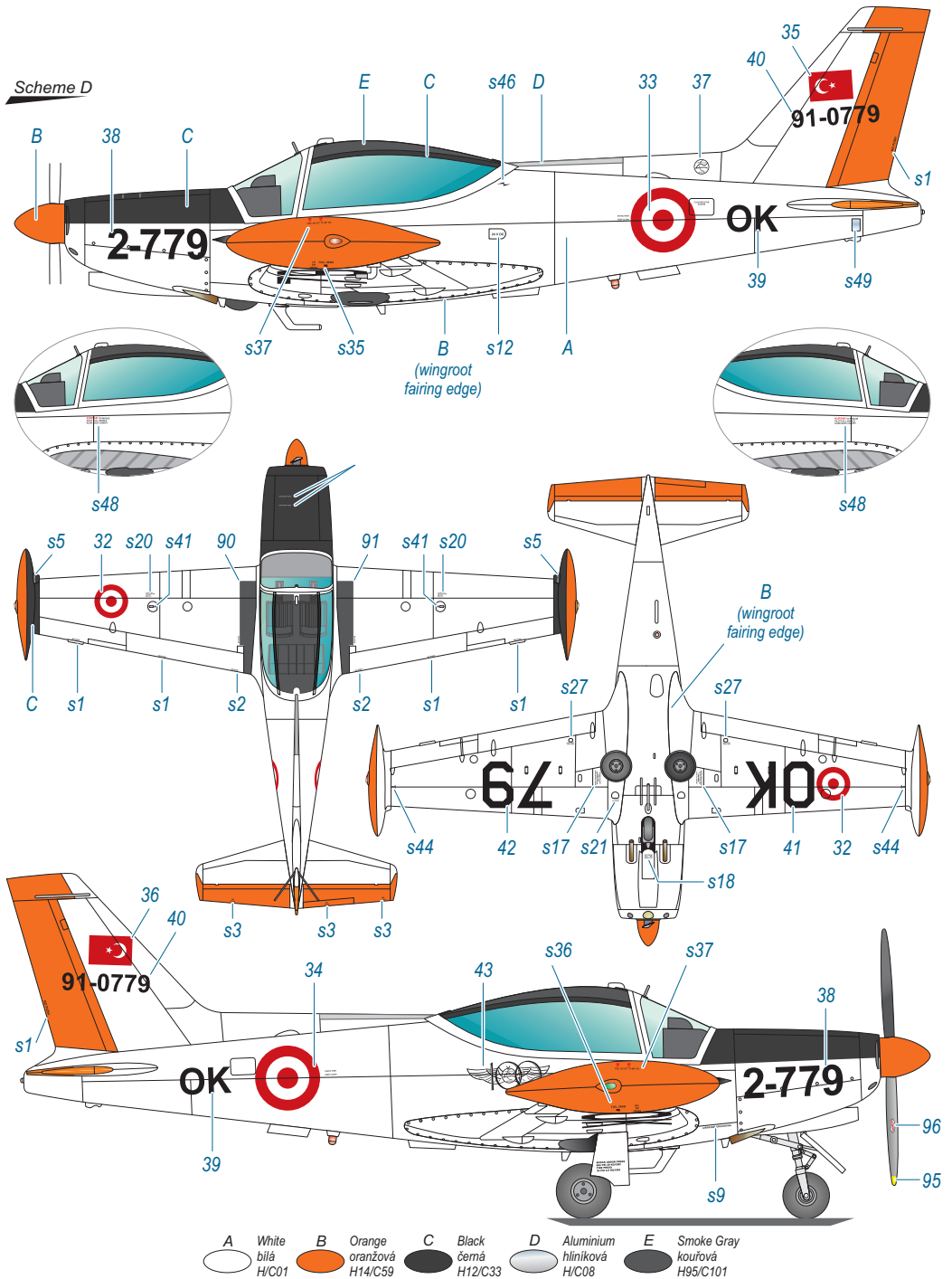

SIAI-Marchetti SF-260D, N405FD, Sky West Aviation Inc Trustee, Albuquerque, NM, USA. The depicted machine originally flew with the Air Combat USA Inc. The new operator, however, have their machines based in the UK.

SIAI Marchetti SF-260D, N405FD, Sky West Aviation Inc Trustee, Albuquerque, NM, USA. N405FD létal původně u společnosti Air Combat USA Inc. Nový vlastník ale letoun používá ve Velké Británii.

**Scheme E**

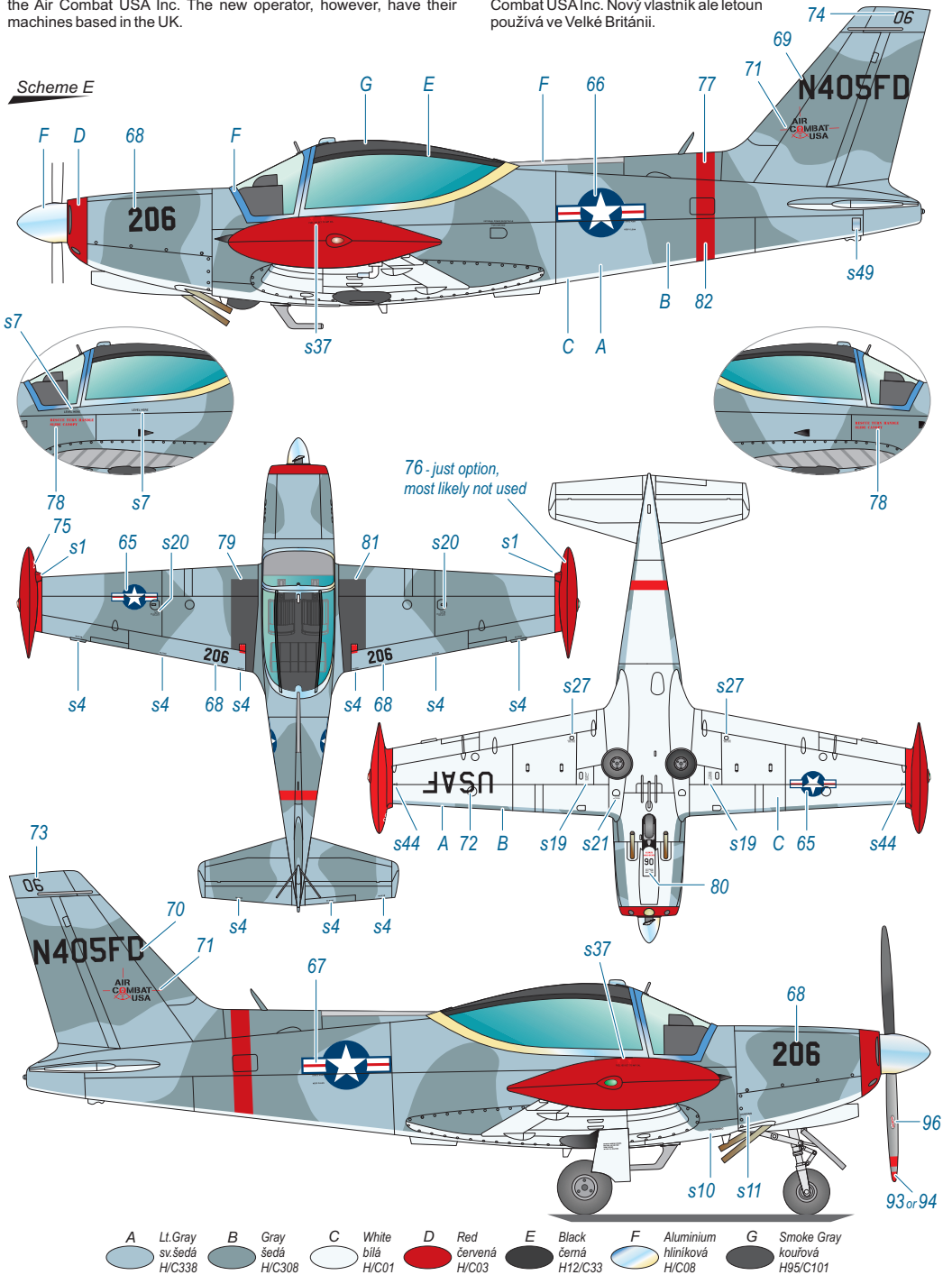

SIAI-Marchetti SF-260AM, 70-21/M.M.54434, 70° Stormo, Aeronautica Militare Italiana, Latina/Enrico Comany Airport, 2005. This airframe received very special, golden-black scheme to commemorate the 50th anniversary of the 70° Stormo of the Italian Air Force. This paint scheme was designed by Maresciallo (highest rank of Italian NCOs) Mirko Porcelli and the tail fin symbol by Maresciallo Pietro Freiles. Now 70-21 is displayed at the base in the open air, carried on pylons.

SIAI Marchetti SF-260AM, 70-21/M.M.54434, Italské letectvo, základna Latina/Enrico Comany, 2005. Letoun dostal speciální černo-zlaté zbarvení k výročí 50 let existence 70° Stormo Aeronautica Militare Italiana. Zbarvení navrhl Maresciallo (poddůstojník) Mirko Porcelli a logo na svislé ocasní ploše Maresciallo (poddůstojník) Pietro Freiles. Nyní je tento letoun umístěn na této základně jako muzejní exemplář na pylonech.

**Scheme F**

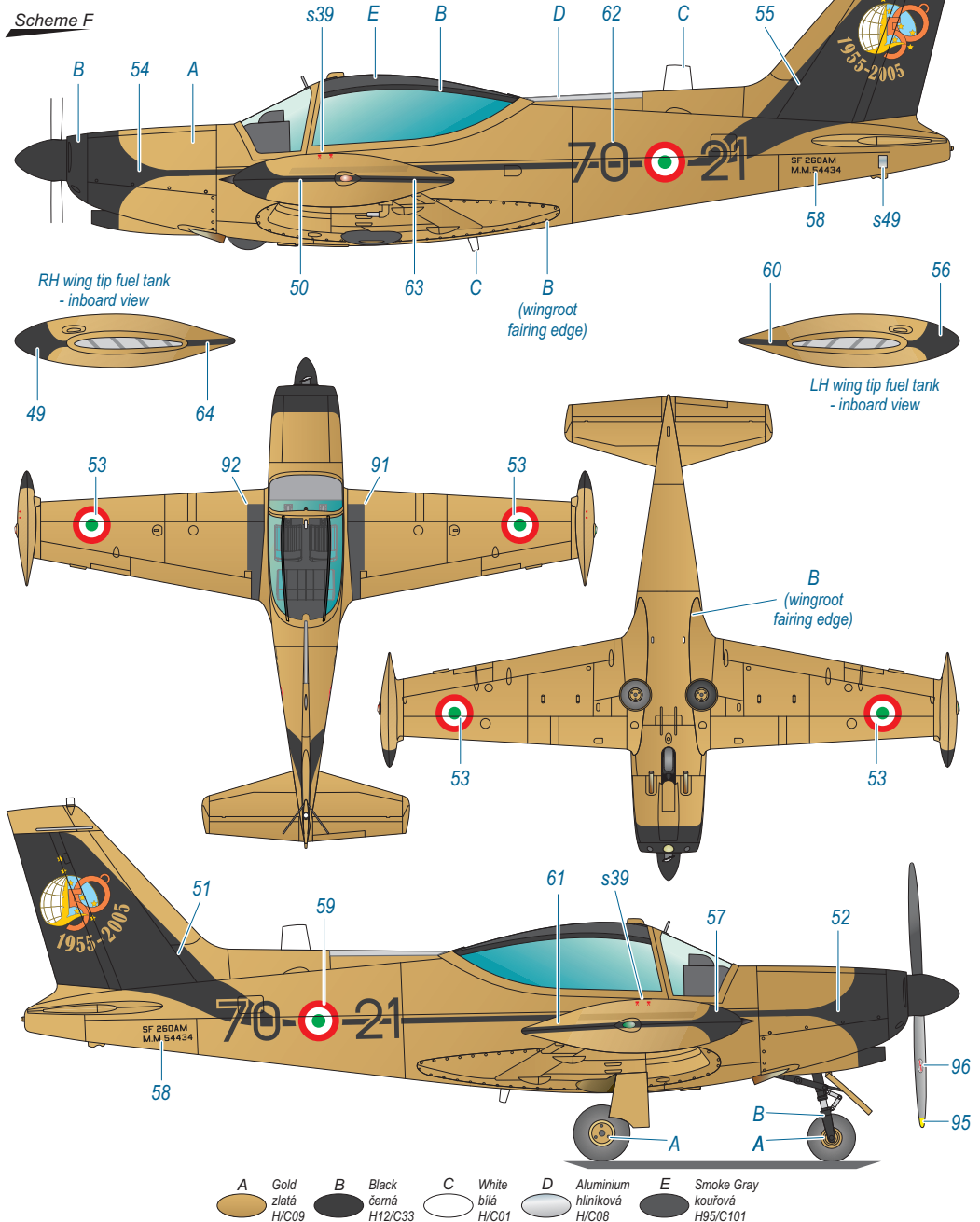

SIAI-Marchetti SF-260WL, no. 603, Free Libya Air Force, ca 2018. The rocket-pods armed SF-260WLs were flown in anti-smuggler and patrol missions over the remote Kufra oasis area and rather porous and remote borders with Egypt, Sudan and Chad.

SIAI Marchetti SF-260WL, 603, letectvo svobodné Libye, cca 2018. Raketnicemi vyzbrojené stroje SF-260 jsou nasazené proti pašerákům v jinak špatně dostupných oblastech oázy Kufra a nad chabě střeženými hranicemi s Egyptem, Súdánem a Čadem.

**Scheme G**

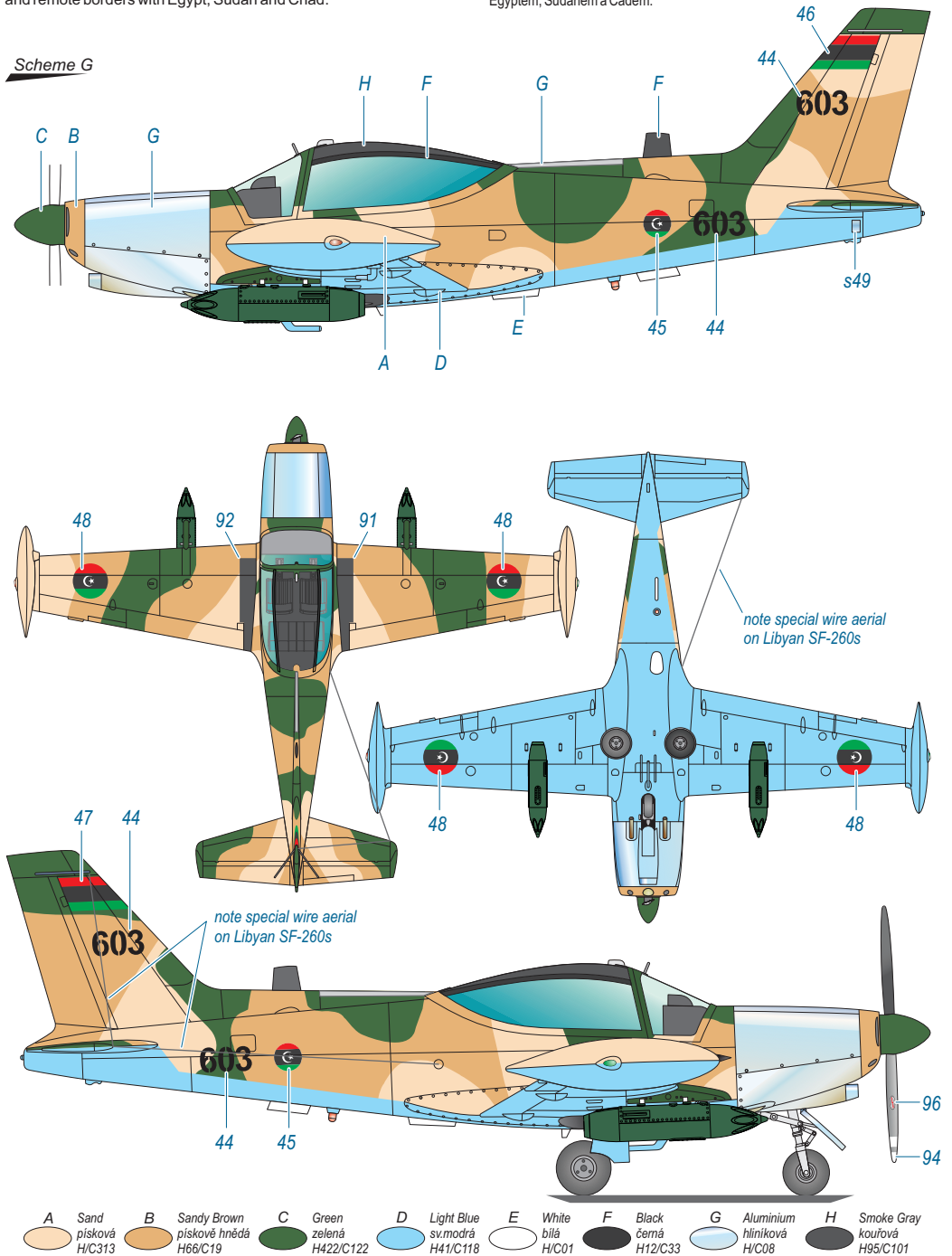

SIAI-Marchetti SF-260W, TS-TBP, W41-503, No. 14 Sqn, Tunisia Air Force, temporarily based at Latina, Italy in July 2008. Along with sister machine TS-TBE, it took part in a joint exercise with pilots of Italian 207° Gruppo, 70° Stormo. Normally, the home base of Tunisian No. 14 Sqn is Sfax.

SIAI Marchetti SF-260W, TS-TBP, tuniské letectvo, základna Latina, Itálie, červenec 2008. Spolu se strojem TS-TBE se zúčastnil společného cvičení s italskými letci ze 207° Gruppo, 70° Stormo. Normálně stroj operuje ze základny Sfax v Tunisku.

**Scheme H**

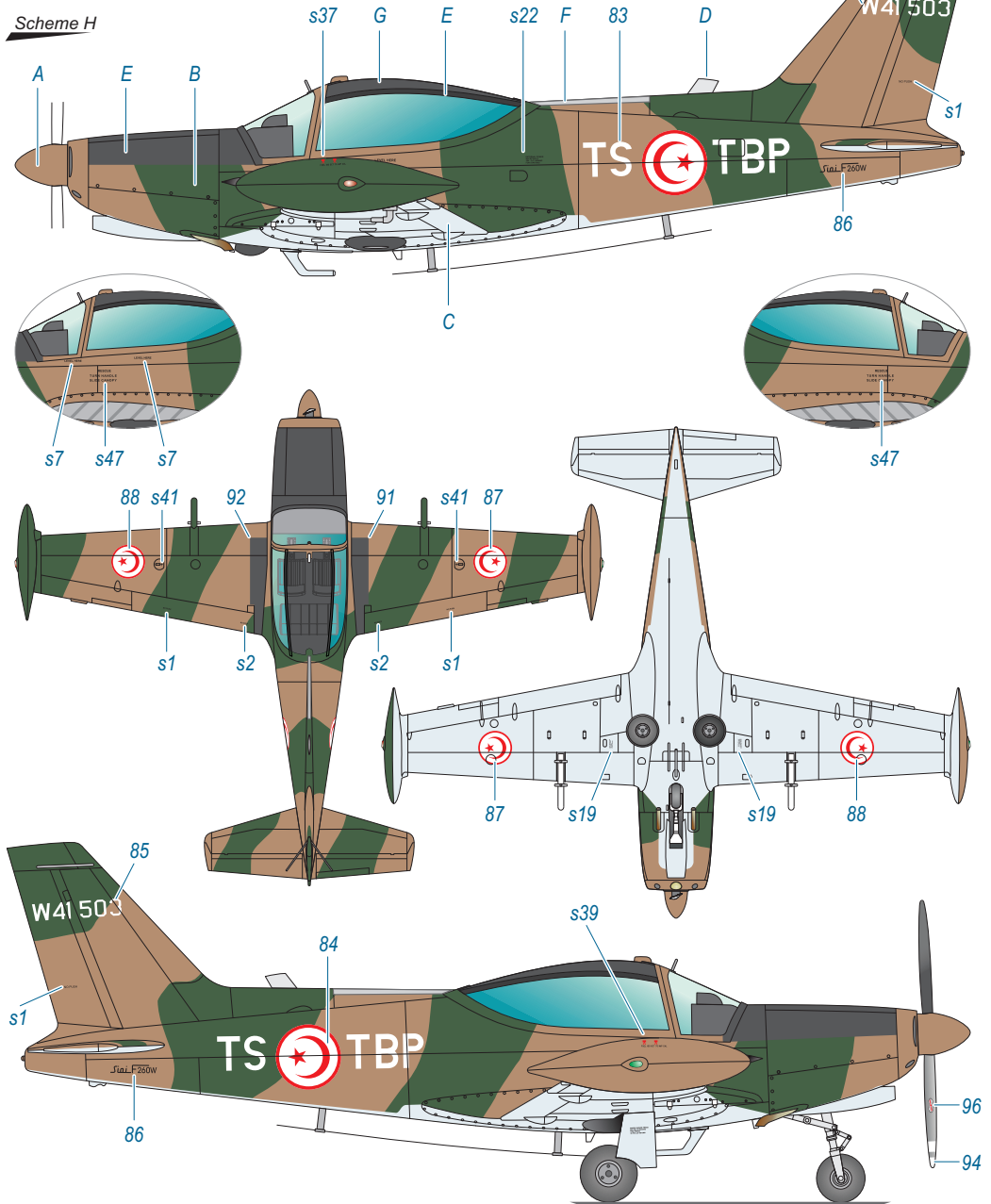

- |   |  |   |                                 |                                    |  |  |
|---|--|---|---------------------------------|------------------------------------|--|--|
| <b>A</b> Earth Brown<br>zemité hnědá<br>H72/C22 | <b>B</b> Dark Green<br>tm.zelená<br>H/C340 | <b>C</b> Light Grey<br>sv.sědá<br>H51/C97 | <b>D</b> White<br>bílá<br>H/C01 | <b>E</b> Black<br>černá<br>H12/C33 | <b>F</b> Aluminium<br>hliníková<br>H/C08 | <b>G</b> Smoke Gray<br>kouřová<br>H95/C101 |
|---|--|---|---------------------------------|------------------------------------|--|--|

# ATTRACTIVE 1/72 SCALE MODELS & SETS

## SH72414 Mirage F.1 Duo Pack & Book

**M72013**

Mirage F.1 Single Seater Mask

**Special MASK**

**M72014**

Mirage F.1 Two Seater Mask



## SH72417 SMB-2 Super Mystère / Sa'ar Duo Pack & Book

**M72001**

SMB-2 Super Mystere Mask

**Special MASK**

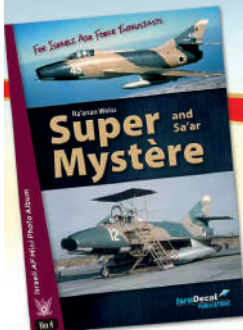

## F-14A Tomcat CMK sets for Academy kit



**7452**  
F-14A Tomcat  
Cockpit



**7453**  
F-14A Tomcat  
Port Side  
Cannon  
Installation



**7454**  
F-14A Tomcat  
Port Engine

## AH-1G/Q/S CMK sets for Special Hobby and Revell kit



**Q72330**  
AH-1G Early  
Emerson Electric  
TAT-102 (single  
weapon) turret



**Q72331**  
AH-1G  
Emerson  
Electric M28  
(dual weapon) turret



**Q72338**  
AH-1Q/S  
Hughes M65  
Telescopic  
Sight Unit



**F72349**  
AH-1  
Sitting pilots  
(2 figures)  
and ground  
crew  
(1 figure)

**Special HOBBY**

[facebook.com/specialhobby](https://www.facebook.com/specialhobby)

[WWW.SPECIALHOBBY.EU](http://WWW.SPECIALHOBBY.EU) | [WWW.CMKKITS.COM](http://WWW.CMKKITS.COM)

**CMK**  
CZECH  
MASTERS KITS