

SW 72130

scale 1/72 

TBM-3S / Avenger AS.4



The original Avenger was developed for the U.S. Navy and U.S. Marine corp. as a torpedo bomber, and entered service in 1942. Over time the aircraft was further developed to carry airborne radar in anti-shipping and anti-submarine roles. The TBM-3S was an anti-submarine version produced post WWII at the onset of the Cold War. The TBM-3S usually flew with a TBM-3W as a 'Hunter / Killer' team. The 3S was a converted 3E, with the turret removed, and had a larger rear compartment housing a radar operator / navigator. The radio compartment was retained with its operator, but two sonobuoy launch tubes were installed at the rear. A search light was mounted under the port wing and an AN/APS-4 radar pod under the starboard wing. The Royal Navy / Fleet Air Arm aircraft were designated AS-4 and their air-to-surface radar was mounted in a 'dustbin' type radome under the fuselage. The TBM-3S and similar TBM-3S2 could carry rockets with zero-length launch mounts under each wing. A single acoustic torpedo or 4 bombs / depth-charges could be carried in the bomb-bay. The aircraft had an antenna / receiver for the radar data-link from a TBM-3W. The TBM-3S was used by several countries including Canada, France, Japan, and the Dutch. Details such as canopies and other components varied between countries.

The TBM-R was a converted TBM-3W or TBM-3S. Combat gear was removed and the rear canopy either glazed or covered over. It was developed during the Korean War as a COD (carrier onboard delivery) and had seating for 7 passengers in the rear compartment. It could also carry stretchers in the bomb-bay, or a cargo basket which could quickly be exchanged on the ground or on deck.

VISION SWORD s.r.o. Těšínská 288
739 34 Šenov
CZECH REPUBLIC

www.swordmodels.cz
e-mail: swordmodels@gmail.com

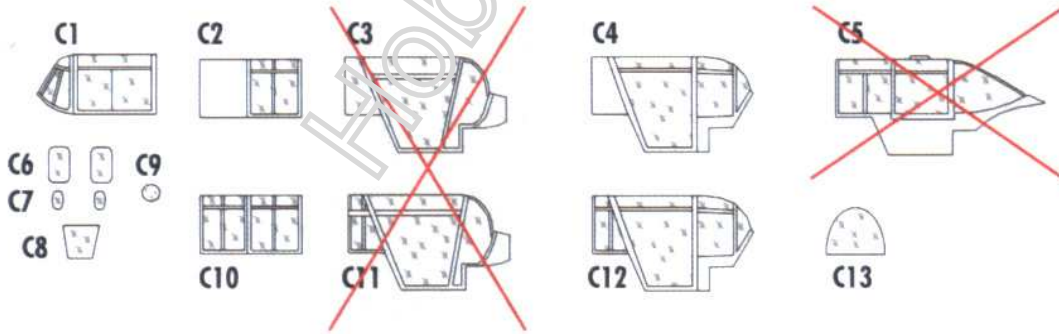
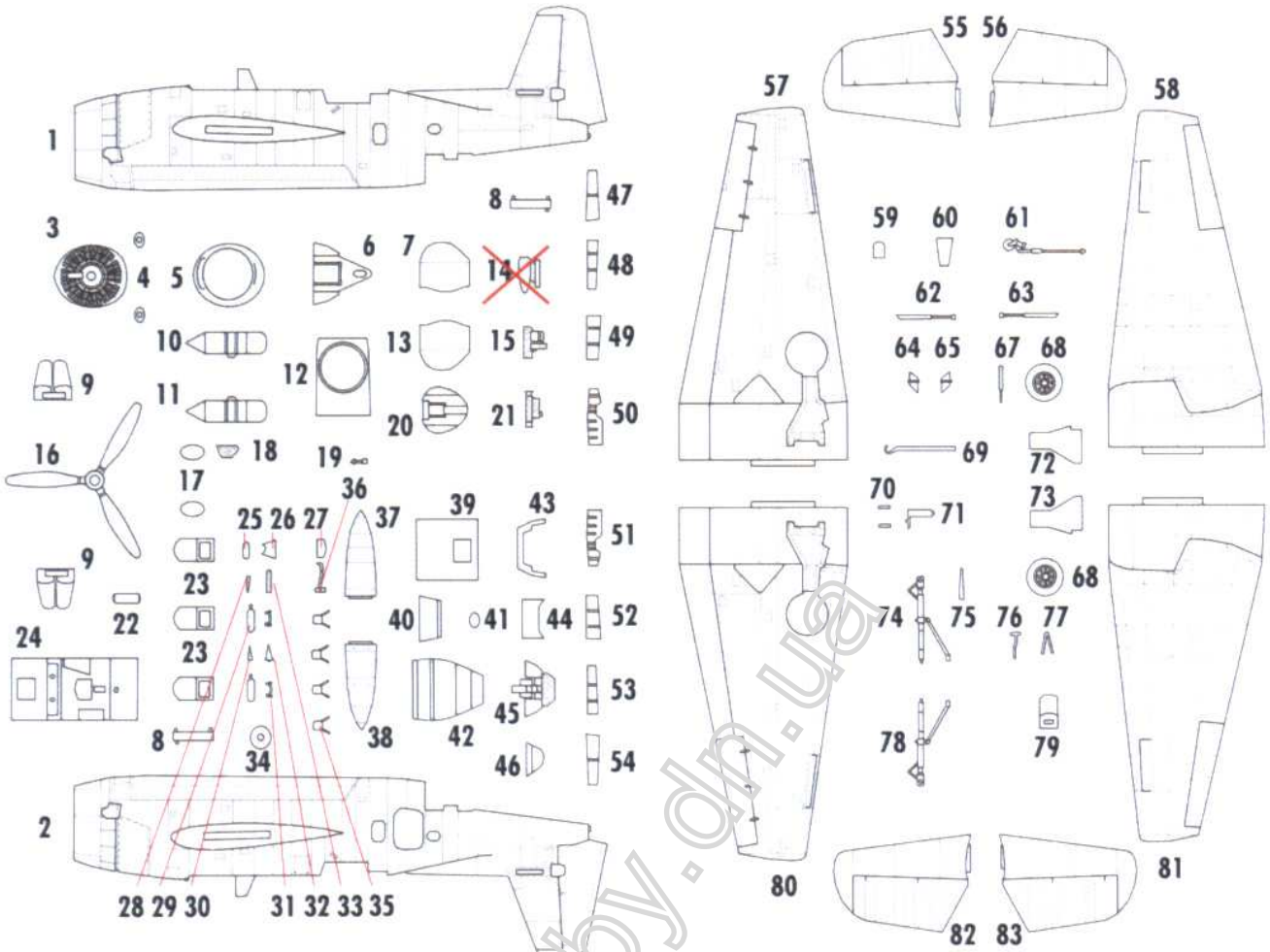

- 
REMOVE
- 
BEND
- 
OPEN HOLE
- 
SCRATCH BUILD
- 
COLOR
- 
SYMMETRICAL ASSEMBLY
- 
OPTION
- 
SECOND GLUE

- | | | | | | | |
|---|---|--|---|---|---|---|
| 
White | 
Light Grey | 
Exhaust | 
Tyres Black | 
Black | 
Bronze Green | 
Gloss Sea Blue |
| 
Silver | 
Yellow | 
Chrome | 
Interior Green | 
Leather | 
Engine Grey | |

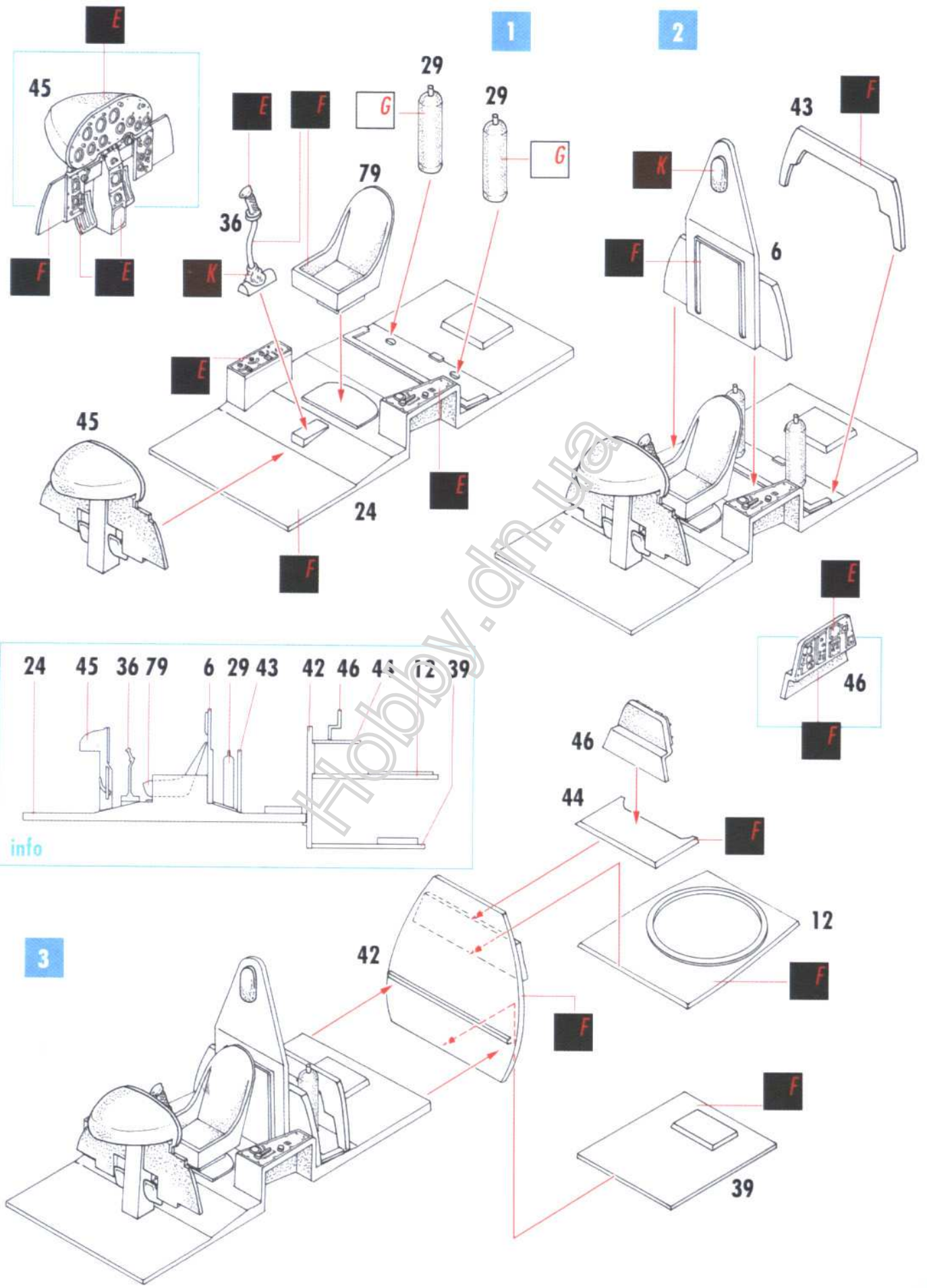

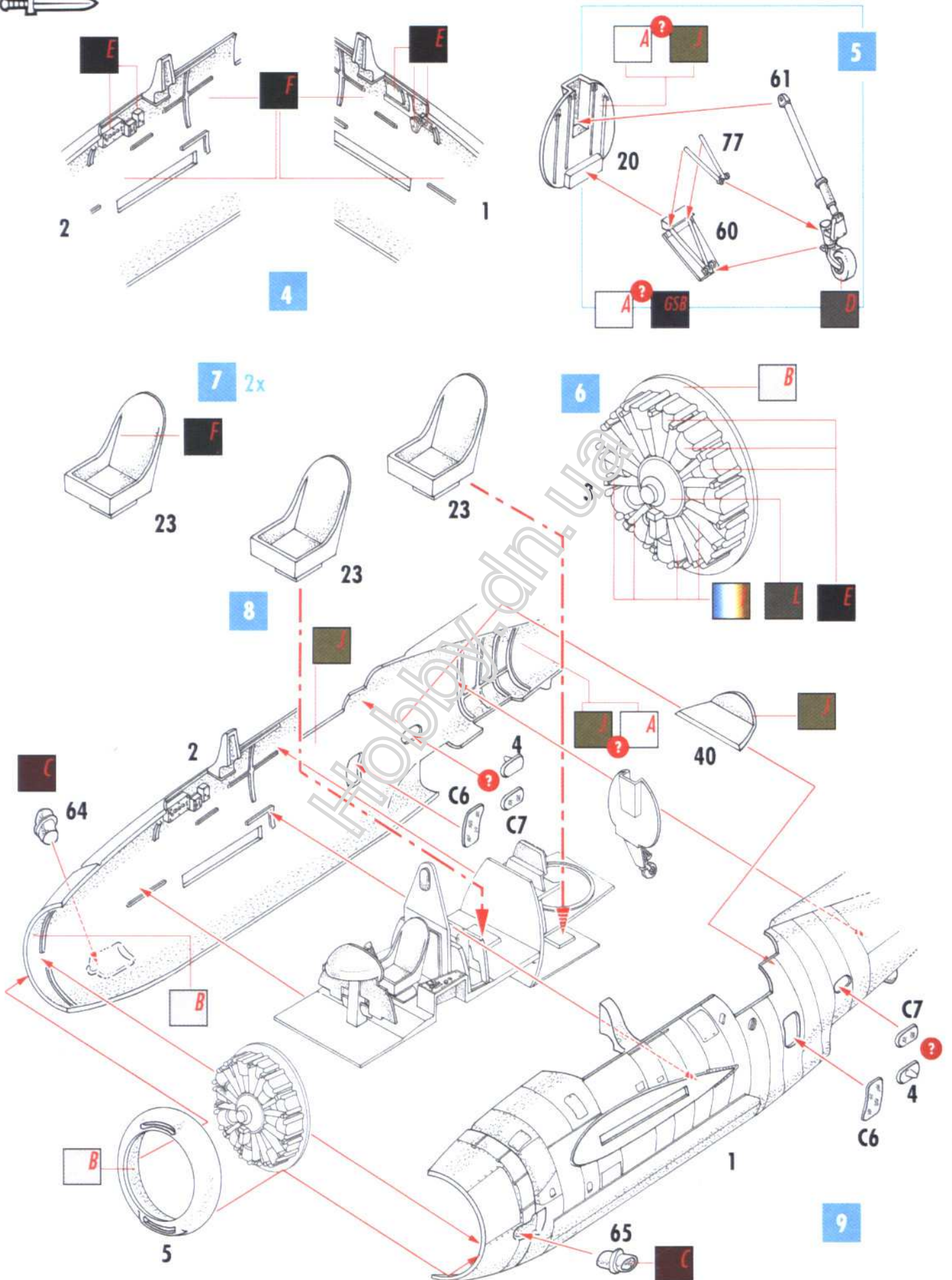

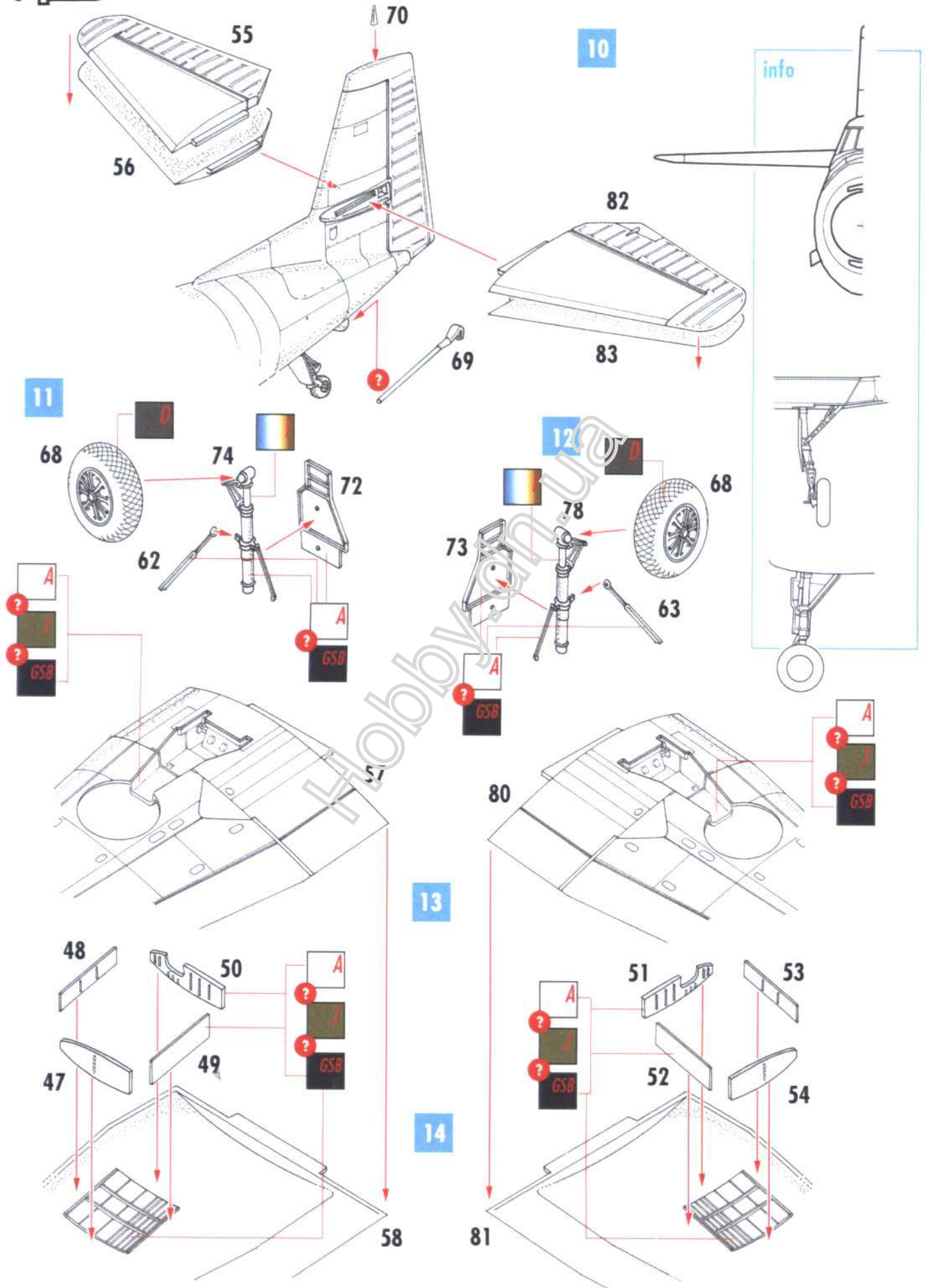

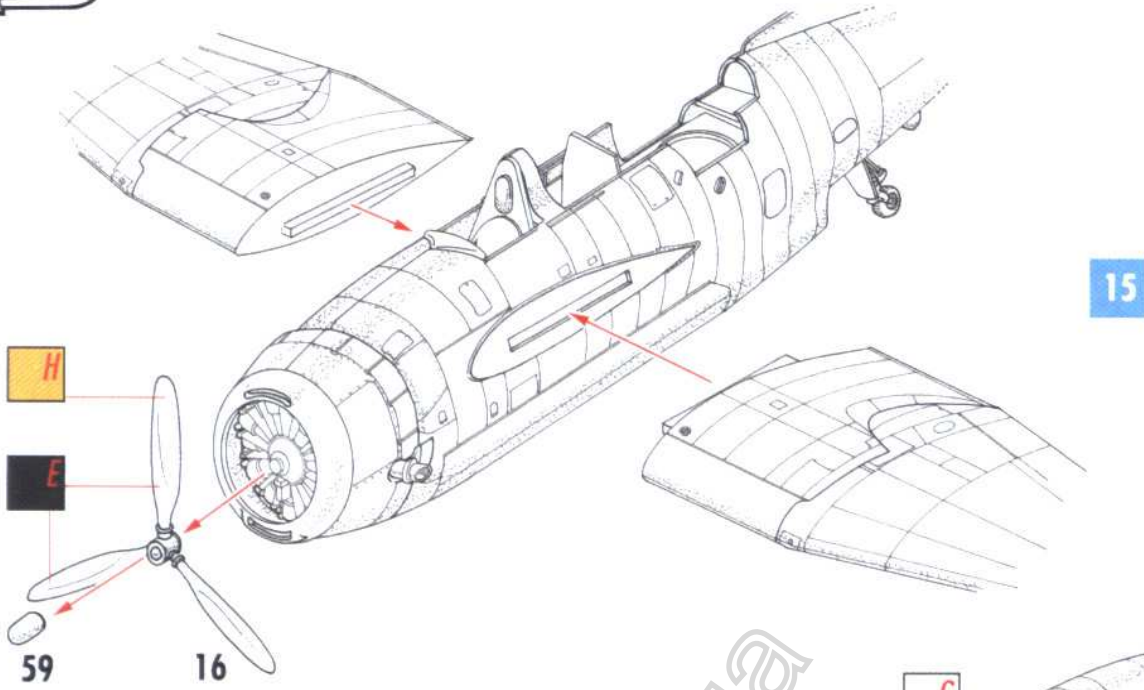

16

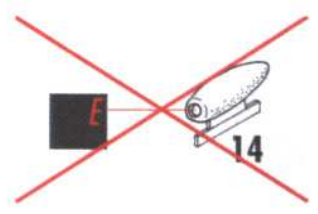
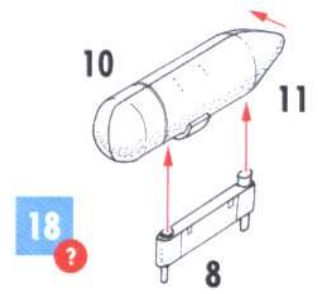
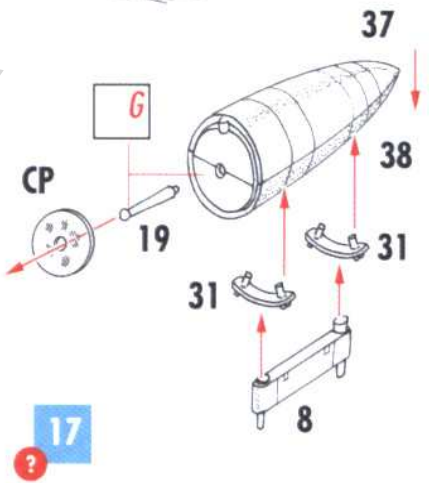
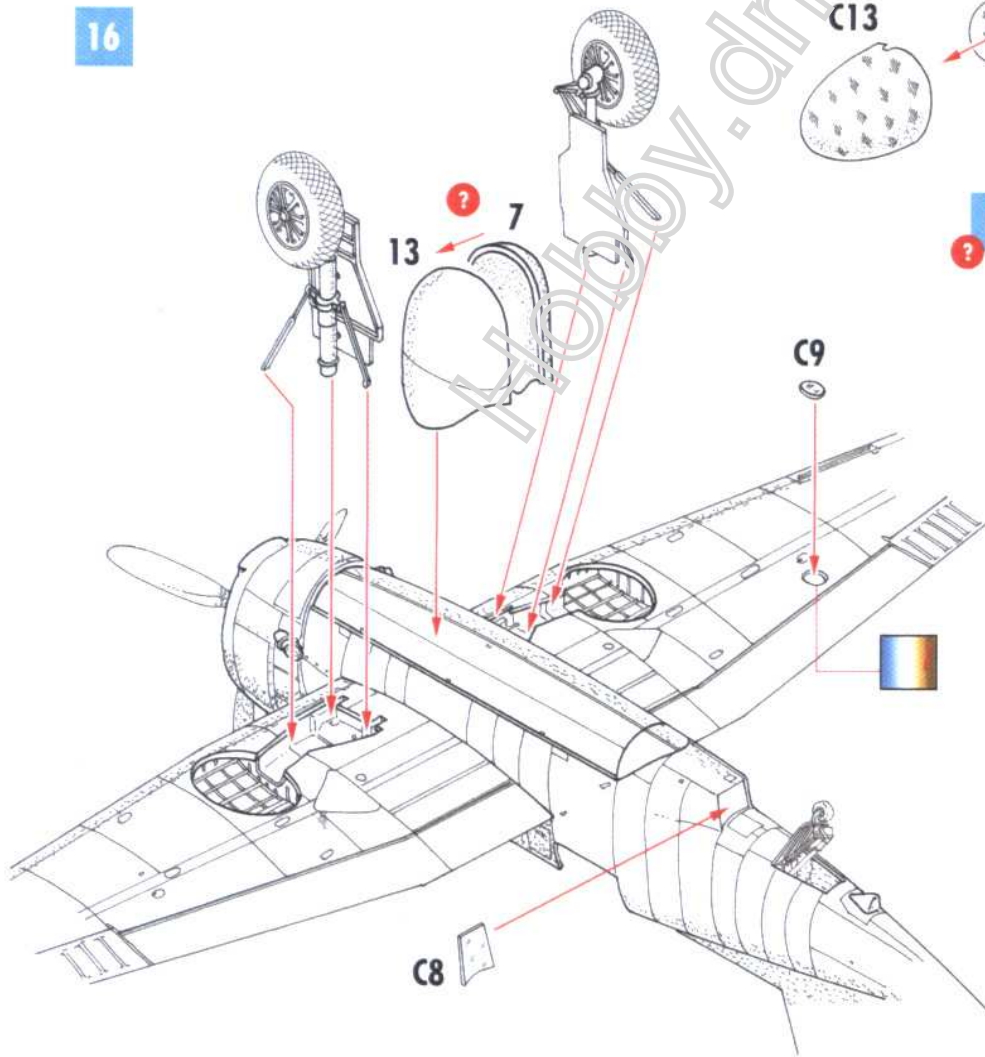

19

20

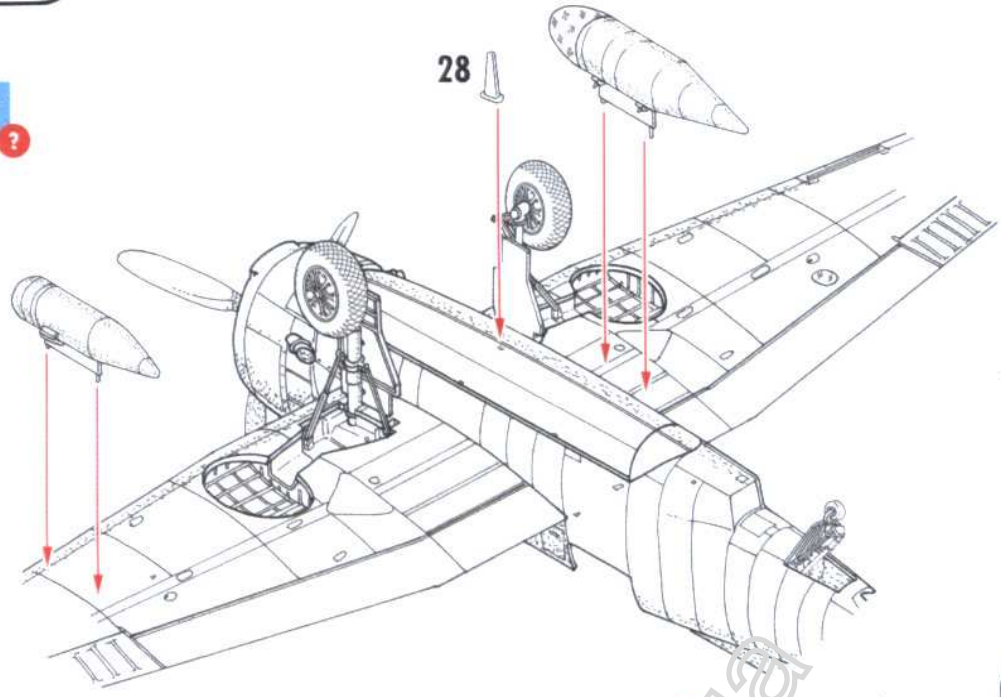

28

21

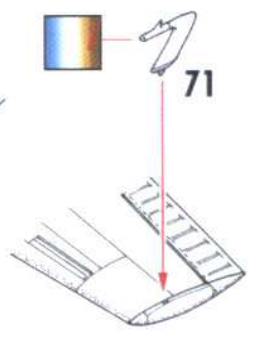

71

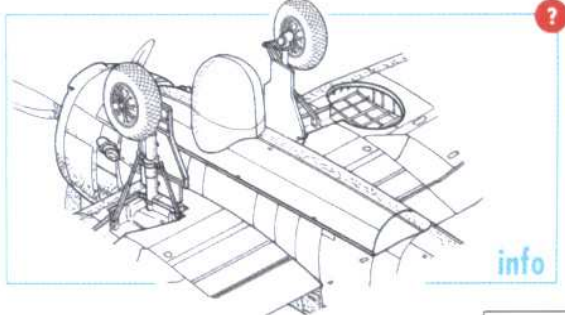

info

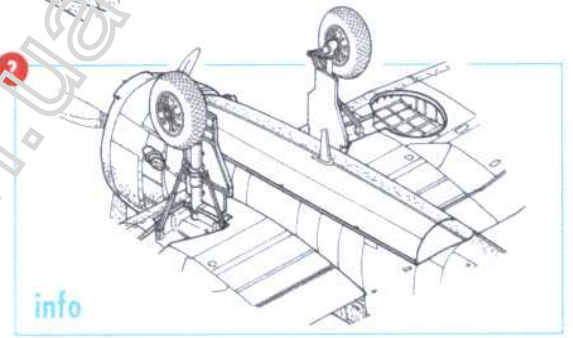

info

22

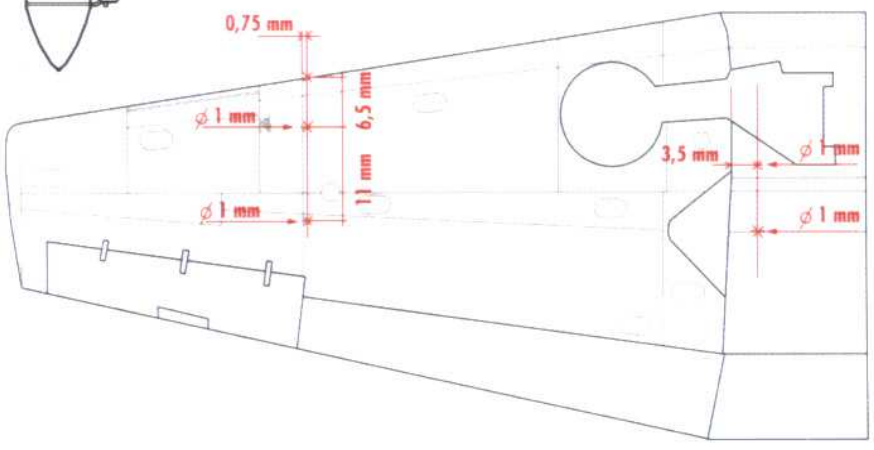
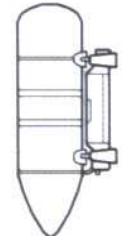
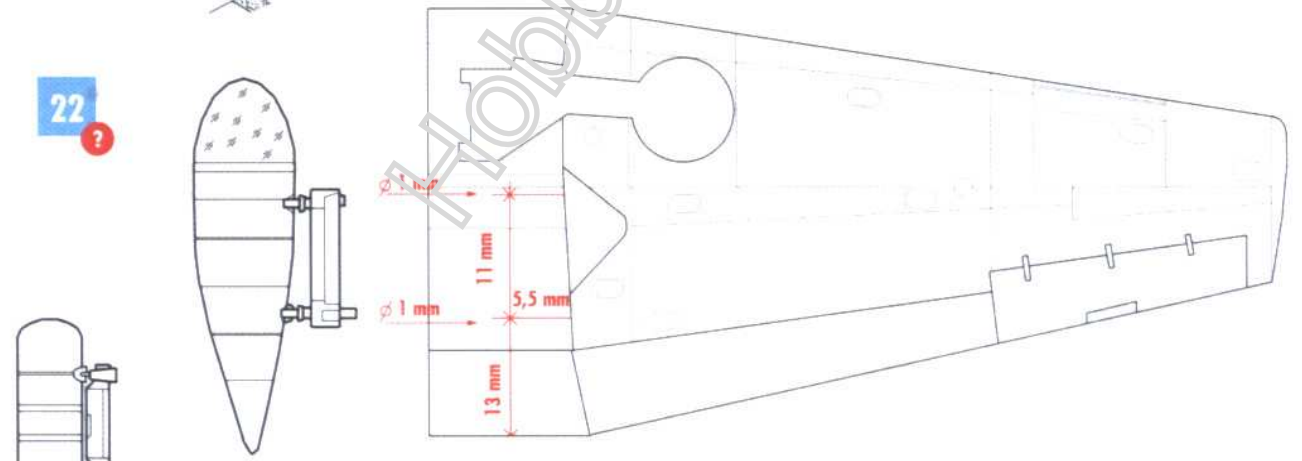

23

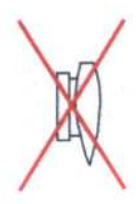

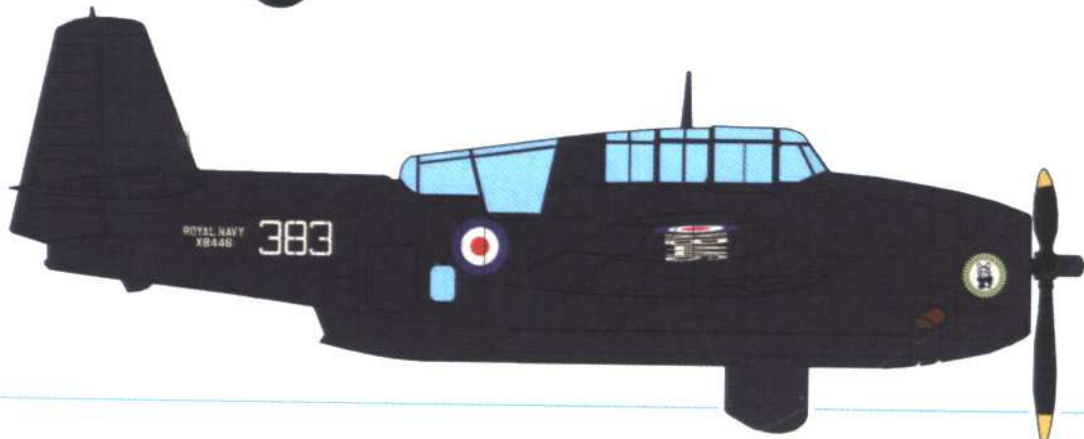
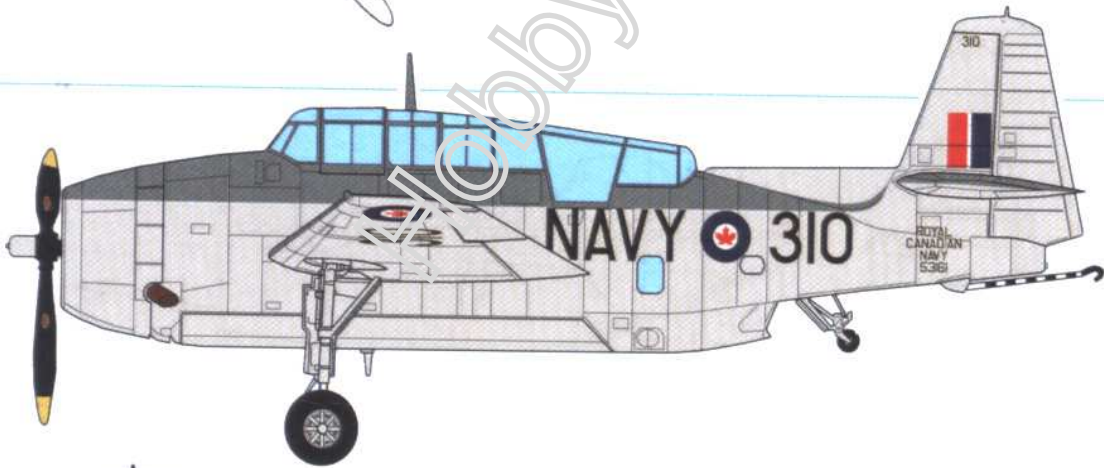
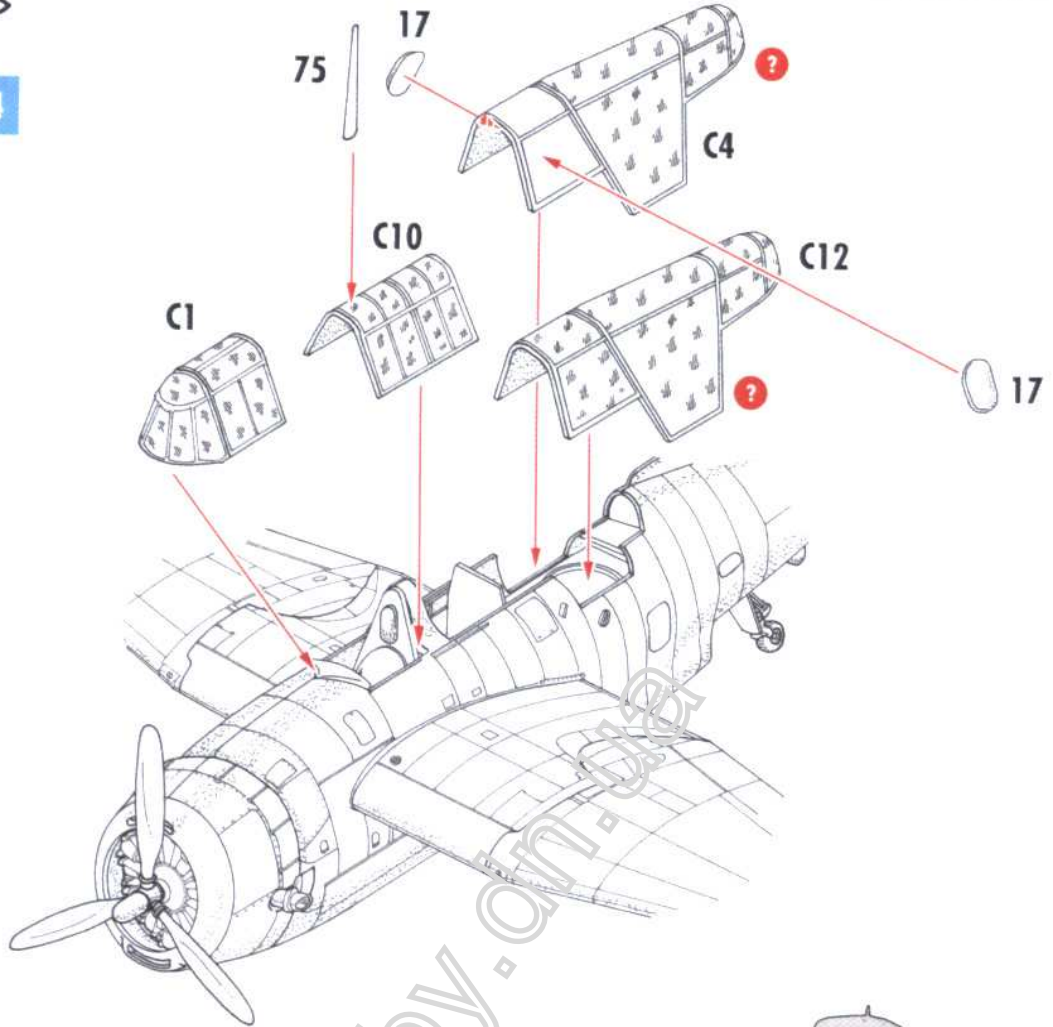

Avenger AS.3, Royal Canadian Navy, 881 Squadron, 1955

