

SW 72134

scale 1/72



# TBM-3U



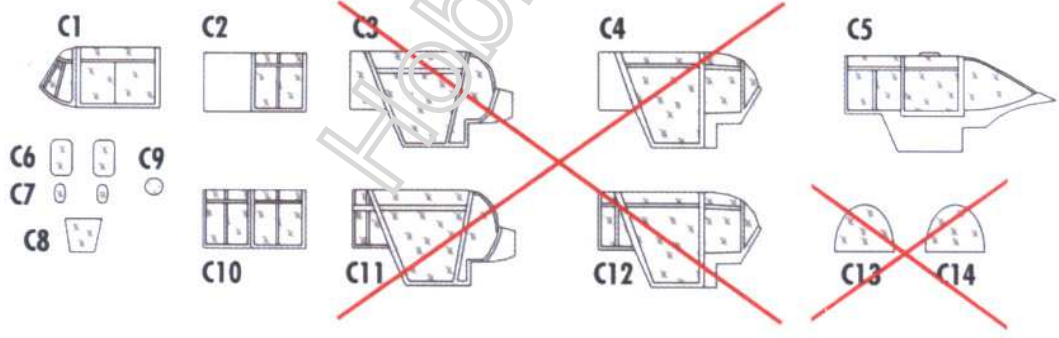
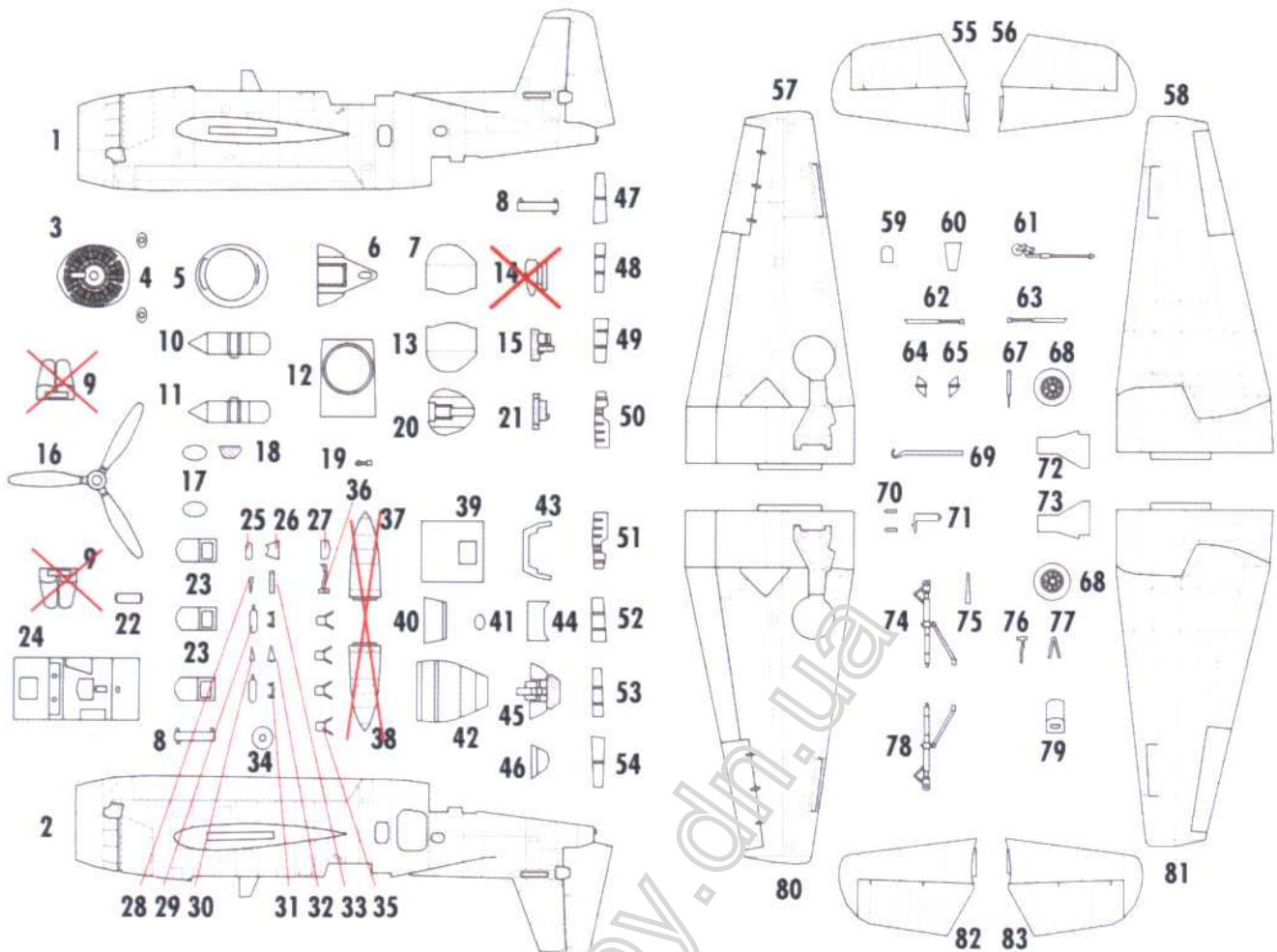

The original Avenger was developed for the U.S. Navy and U.S. Marine corp. as a torpedo bomber, and entered service in 1942. Over time the aircraft was further developed to carry airborne radar in anti-shiping and anti-submarine roles. The TBM-3S was an anti-submarine version produced post WWII at the onset of the Cold War. The TBM-3S usually flew with a TBM-3W as a 'Hunter / Killer' team. The 3S was a converted 3E, with the turret removed, and had a larger rear compartment housing a radar operator / navigator. The radio compartment was retained with its operator, but two sonobuoy launch tubes were installed at the rear. A search light was mounted under the port wing and an AN/APS-4 radar pod under the starboard wing. The Royal Navy / Fleet Air Arm aircraft were designated AS-4 and their air-to-surface radar was mounted in a 'dustbin' type radome under the fuselage. The TBM-3S and similar TBM-3S2 could carry rockets with zero-length launch mounts under each wing. A single acoustic torpedo or 4 bombs / depth-charges could be carried in the bomb-bay. The aircraft had an antenna / receiver for the radar data-link from a TBM-3W. The TBM-3S was used by several countries including Canada, France, Japan, and the Dutch. Details such as conopies and other components varied between countries.

The TBM-R was a converted TBM-3W or TBM-3S. Combat gear was removed and the rear canopy either glazed or covered over. It was developed during the Korean War as a COD ( carrier onboard delivery) and had seating for 7 passengers in the rear compartment. It could also carry stretchers in the bomb-bay, or a cargo basket which could quickly be exchanged on the ground or on deck.



							
REMOVE	BEND	OPEN HOLE	SCRATCH BUILD	COLOR	SYMMETRICAL ASSEMBLY	OPTION	SECOND GLUE

						
White	Light Grey	Exhaust	Tyres Black	Black	Bronze Green	Gloss Sea Blue
						
Silver	Yellow	Chrome	Interior Green	Leather	Engine Grey	

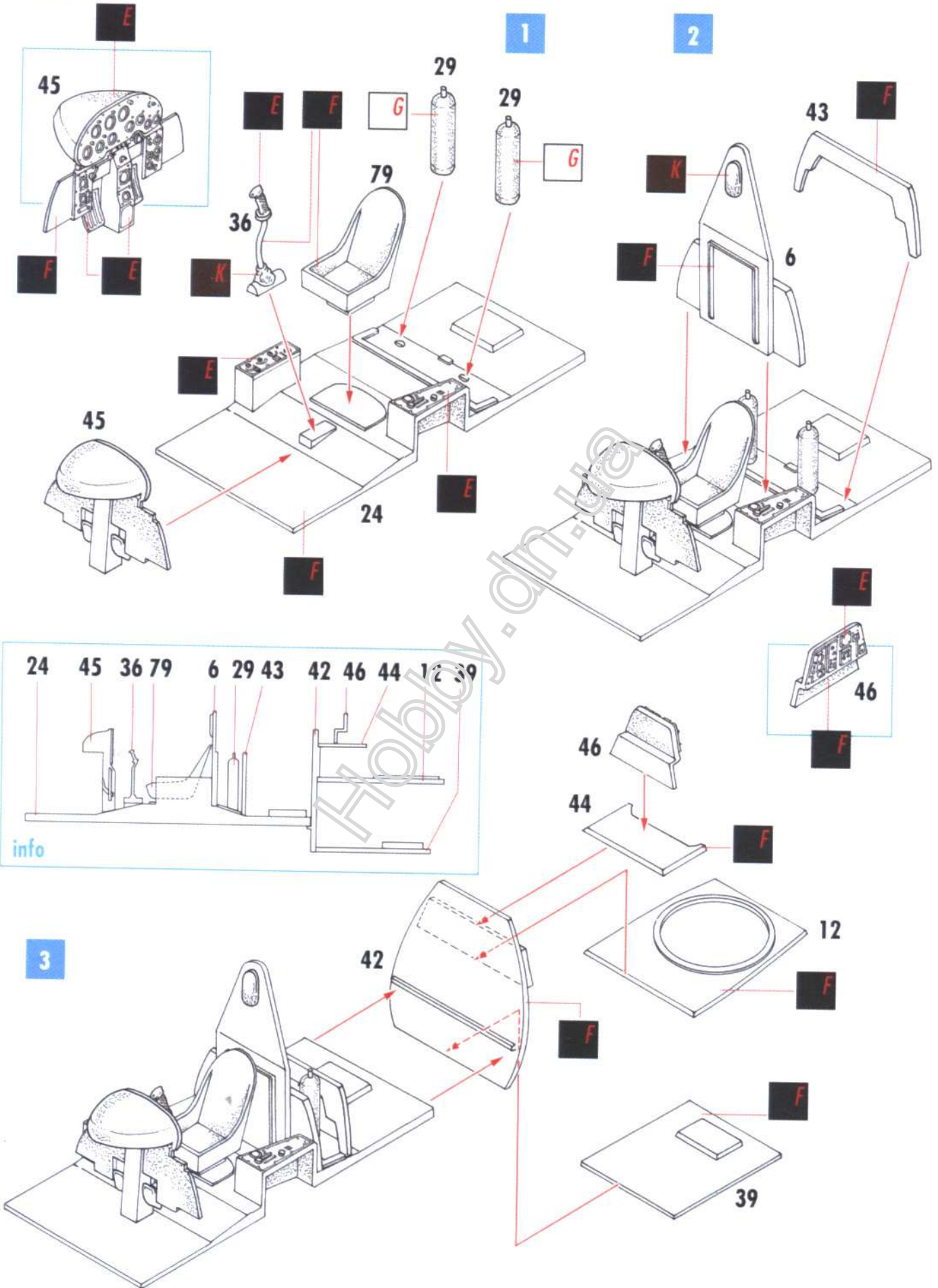

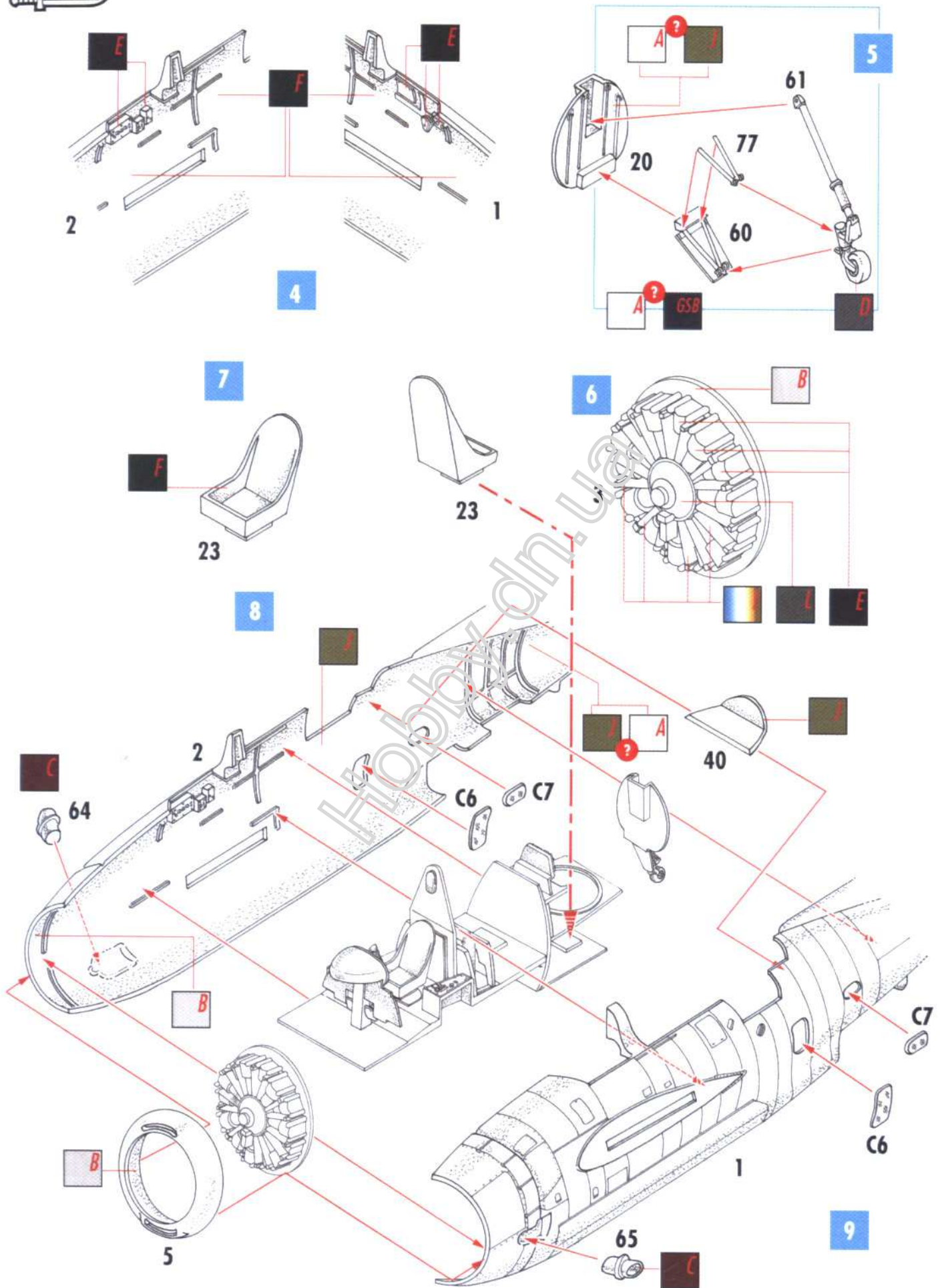

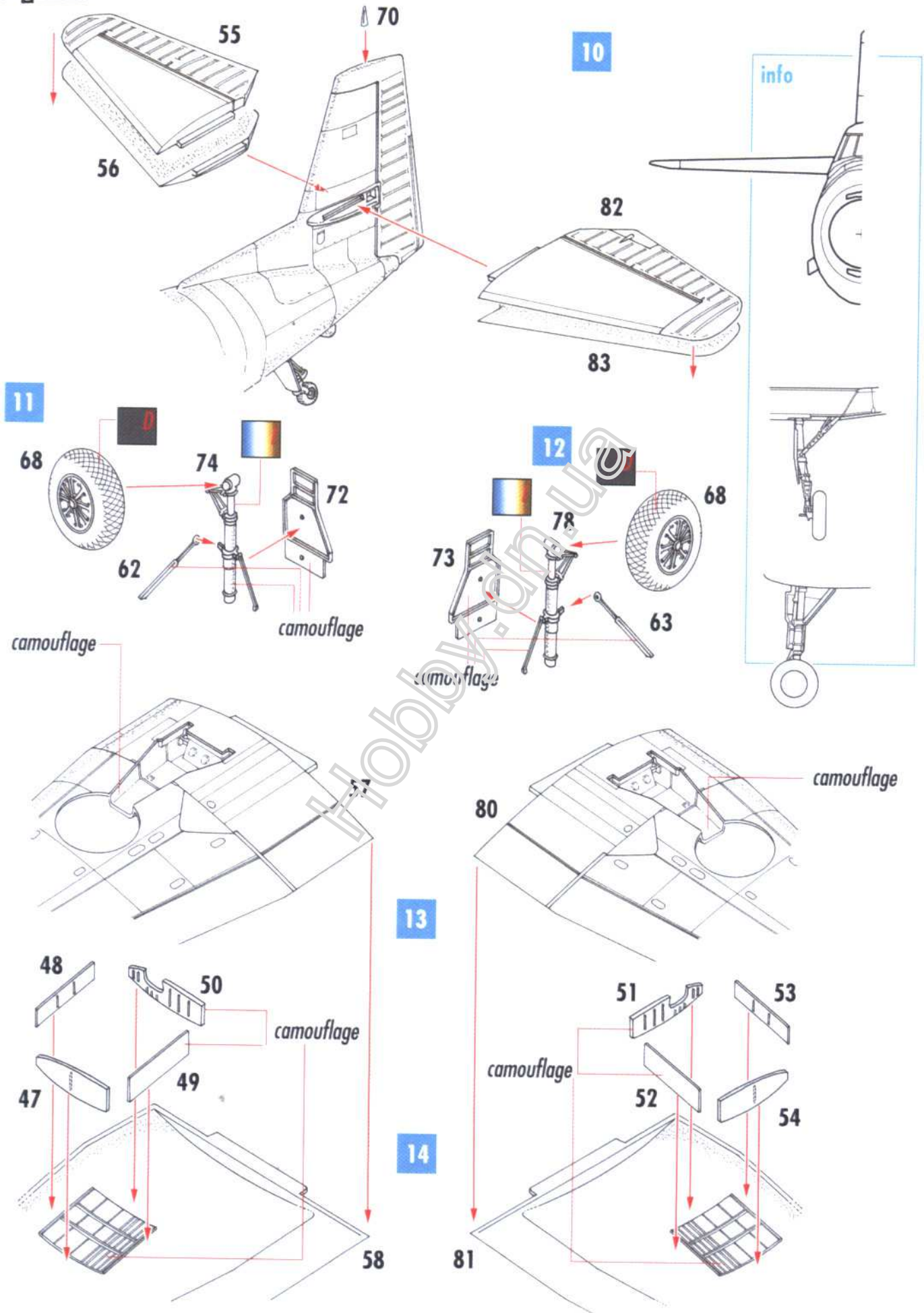

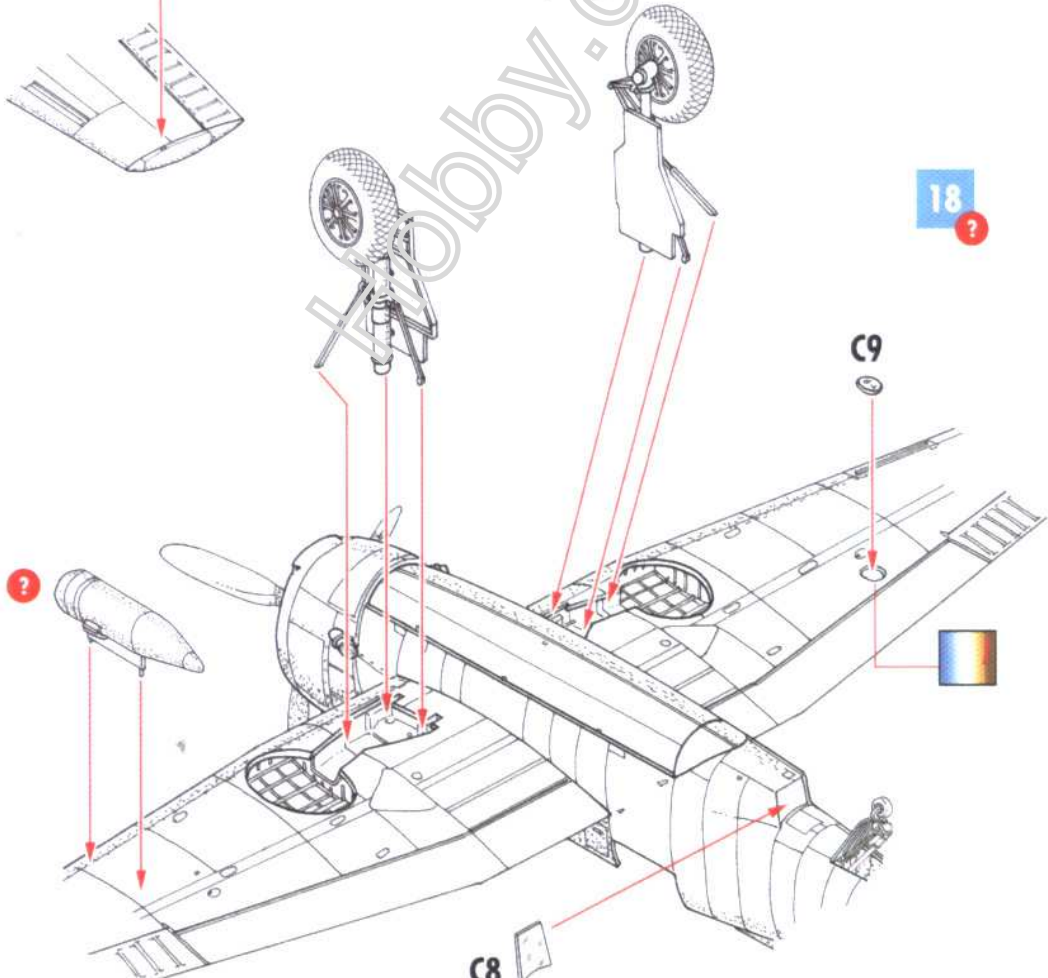
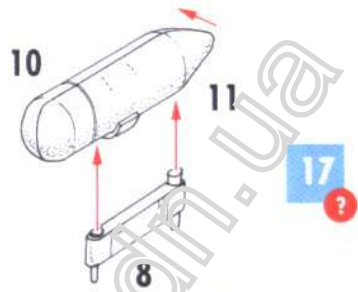
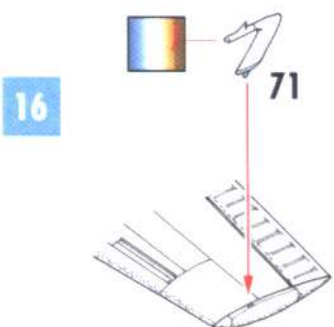
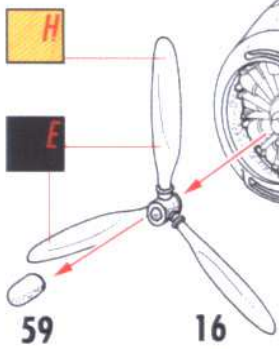
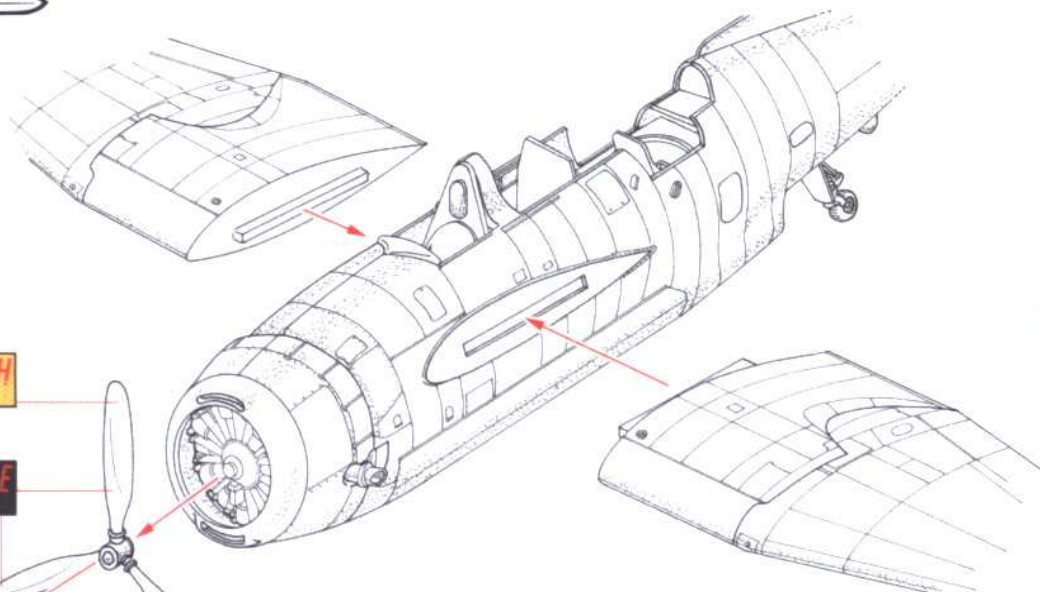

C8  
camouflage

TBM-3U (UH-25, BUNo 69400), Utility Squadron VU-7A at Naval Air Station (NAS) Barbers Point, Oahu, Hawaii, 1948

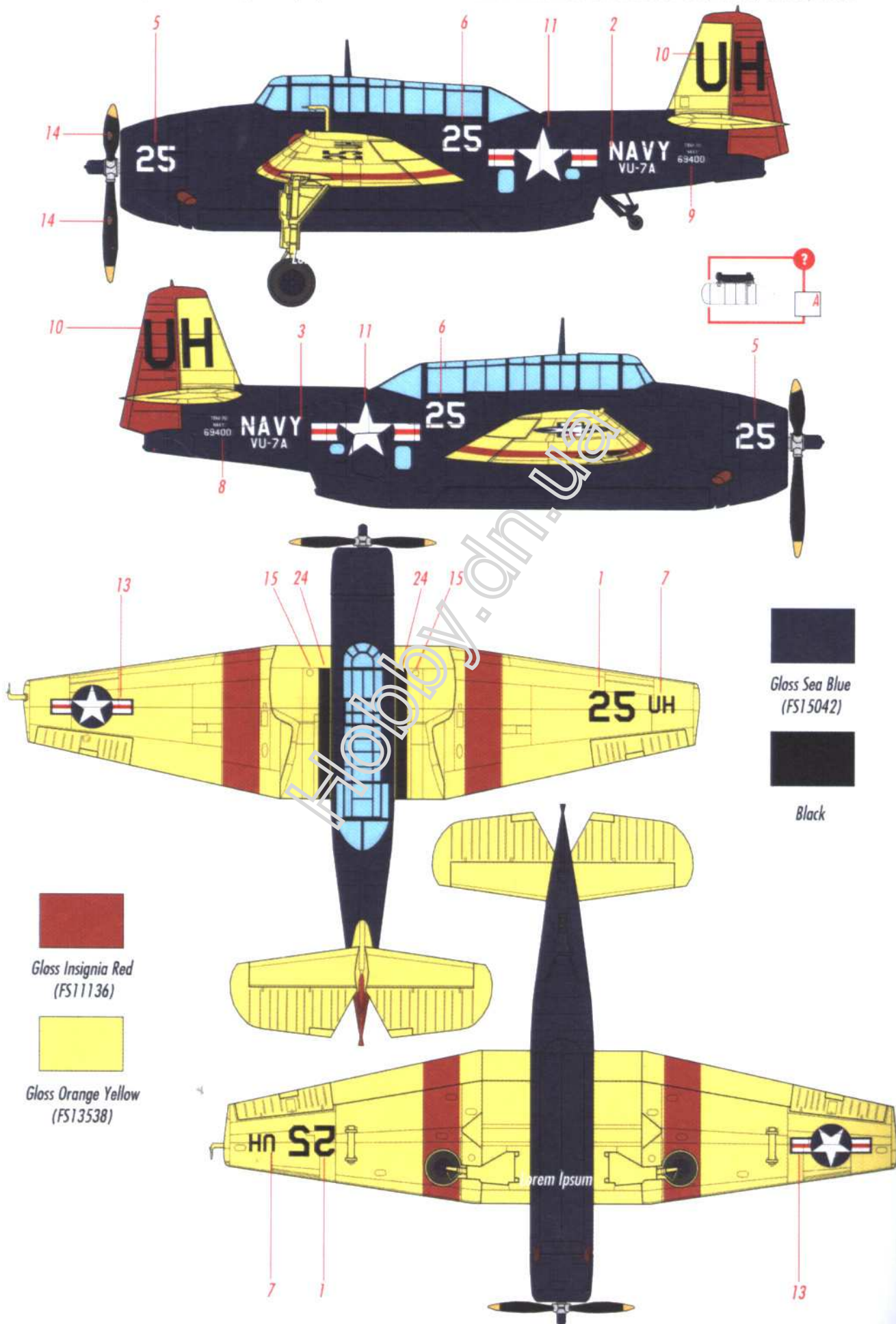

TBM-3U (TD-35, BUNo 69329), Utility Squadron 4 (VU-4) at Naval Air Station (NAS) Norfolk, Virginia, 1948

