

F-3B/C DEMON

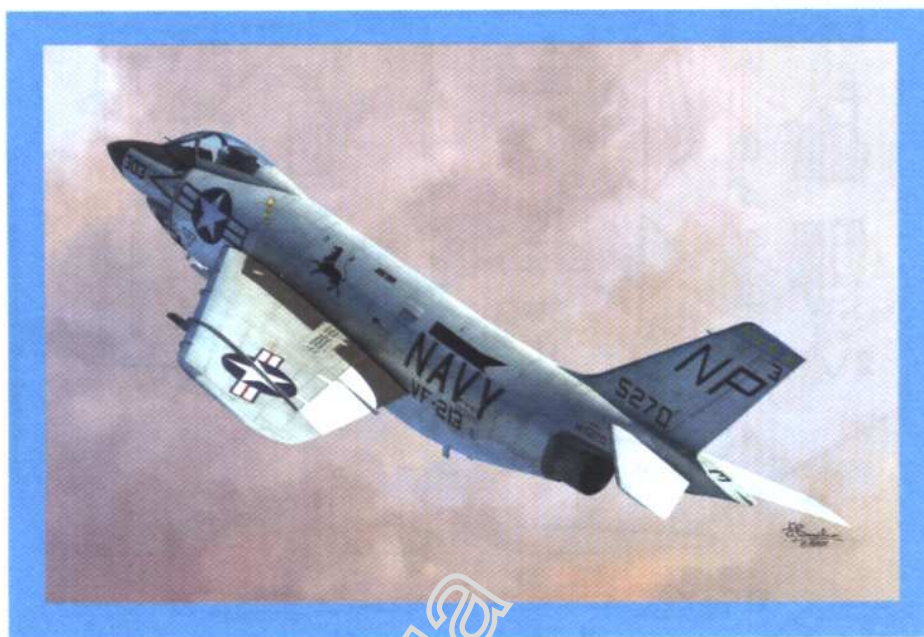

Development began in 1949 for a carrier-based jet fighter. The swept-wing design was to be powered by a single Westinghouse J40, the U.S. Navy's preference at that time, and a departure from McDonnell's usual twin engine layout. The Navy needed a jet fighter to combat the Mig 15 over Korea and ordered the F3H into production even before the prototype FX3H-1 had made its first flight in August 1951. But the J40 was problematic. Lack of power limited the Demon to sub-sonic speed except for in a shallow dive. The first operational design appeared in 1953, too late for the battle. Engine problems and accidents meant the grounding of the Demon. A J40 powered Demon did however break an unofficial time-to-climb record; 10,000ft (3000m) in 71 seconds. Other J40 powered aircraft projects were either shelved or redesigned to be fitted with other engines. The J40 program was itself shelved in 1953. The demon could not be fitted with most of the other engines available without major changes to wings and fuselage. The best option was the Allison J71, the F3H then becoming the F3H-2N. This engine also proved problematic in service; insufficient power, flameouts, compressor-stalls. This version was first flown in 1954, but by then the aircraft also had other problems. An additional order of 239 F3H-2 was however, deployed in 1956. The Demon was retired in 1964. 519 had been built. An F3H-P recon version had been designed, but never built. Armament consisted of 4 x 20mm (0.79 in) Colt Mk 12 cannons, the 2 upper cannons later removed to save weight. The F3H-2M carried Raytheon AAM-N2 Sparrow, and later, Sidewinder missiles. Deployed aircraft would carry both; Sparrows on the inboard mounts, Sidewinders on the outer. Carrier defence omitted the cannons unless installed and armed for specific task such as the 'Cuban missile Crisis'.

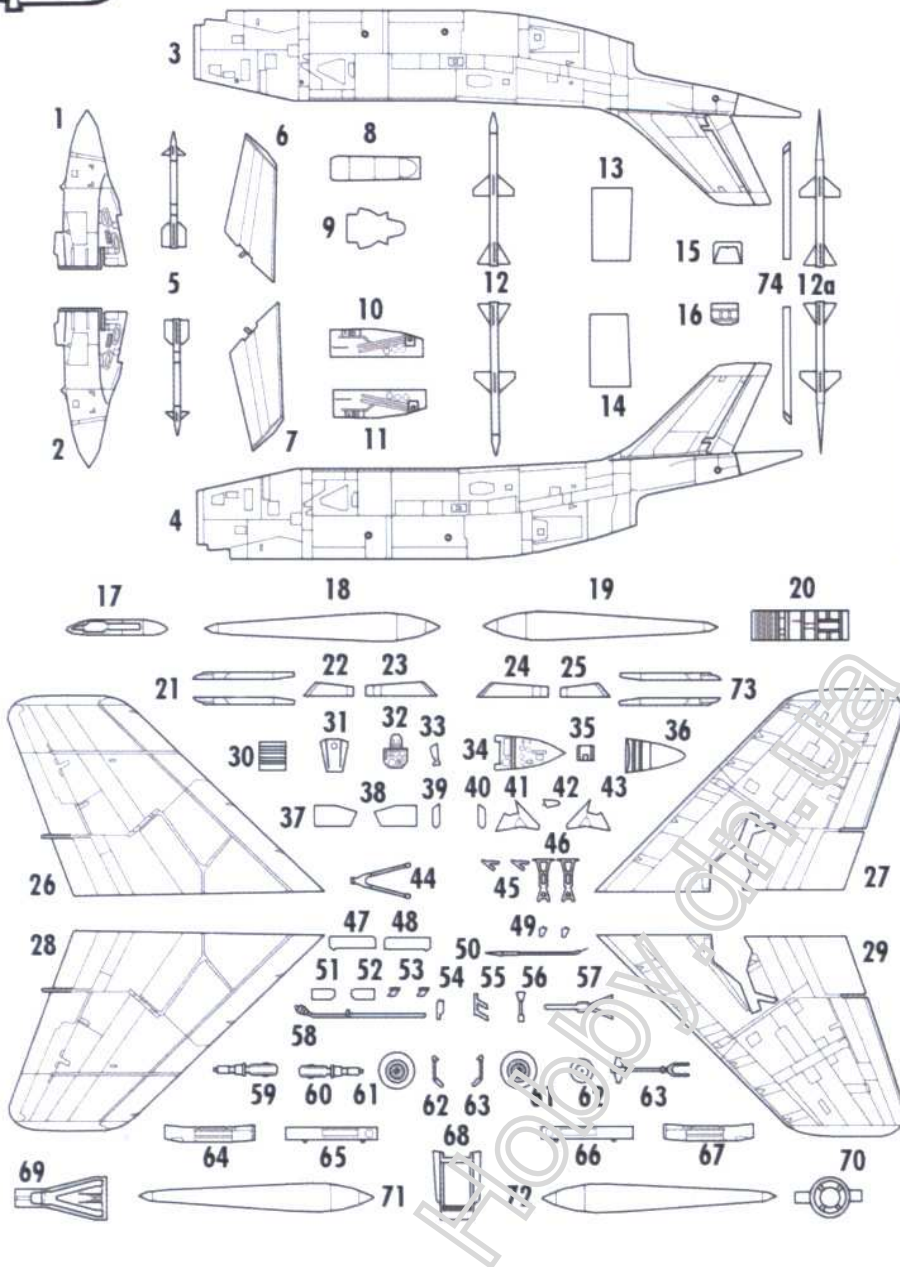

CLEAR

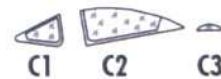
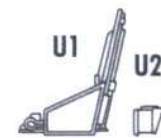

PHOTO-ETCHED



U1 U2



U3



URETHAN

BARVA/COLOR	
A	Černá/Black
B	Khaki
C	Stříbrná/Silver
D	Hliník/Aluminium
E	Světle šedá/Light Grey
F	Bílá/White
G	Žlutá/Yellow
H	Zelená/Green
I	Černošedá/Tyre Black
J	Špinavý hliník/Dirty Aluminium
K	Chromová/Chrome
L	Burn iron/Vypálený kov
M	Kovová/Gun metal
N	Přírodní kov/Natural metal
O	Červená/Red

REMOVE	BEND
OPEN HOLE	SCRATCH BUILD
COLOR	SYMMETRICAL ASSEMBLY
OPTION	SECOND GLUE

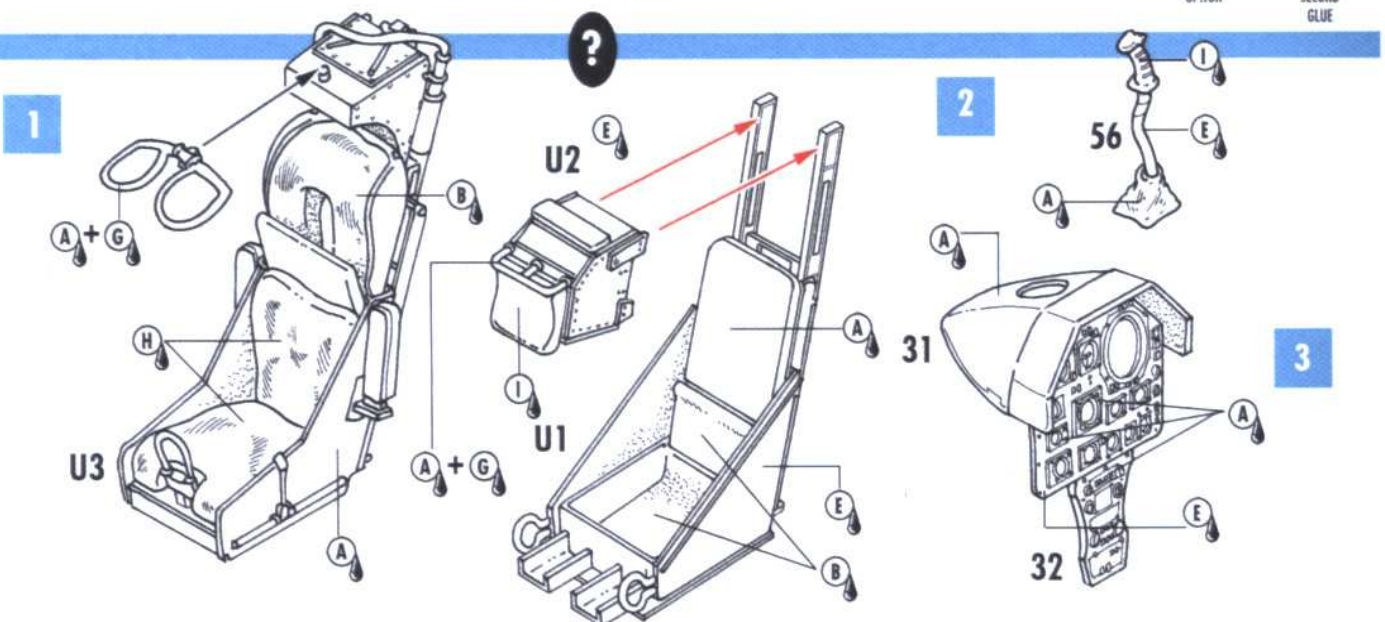

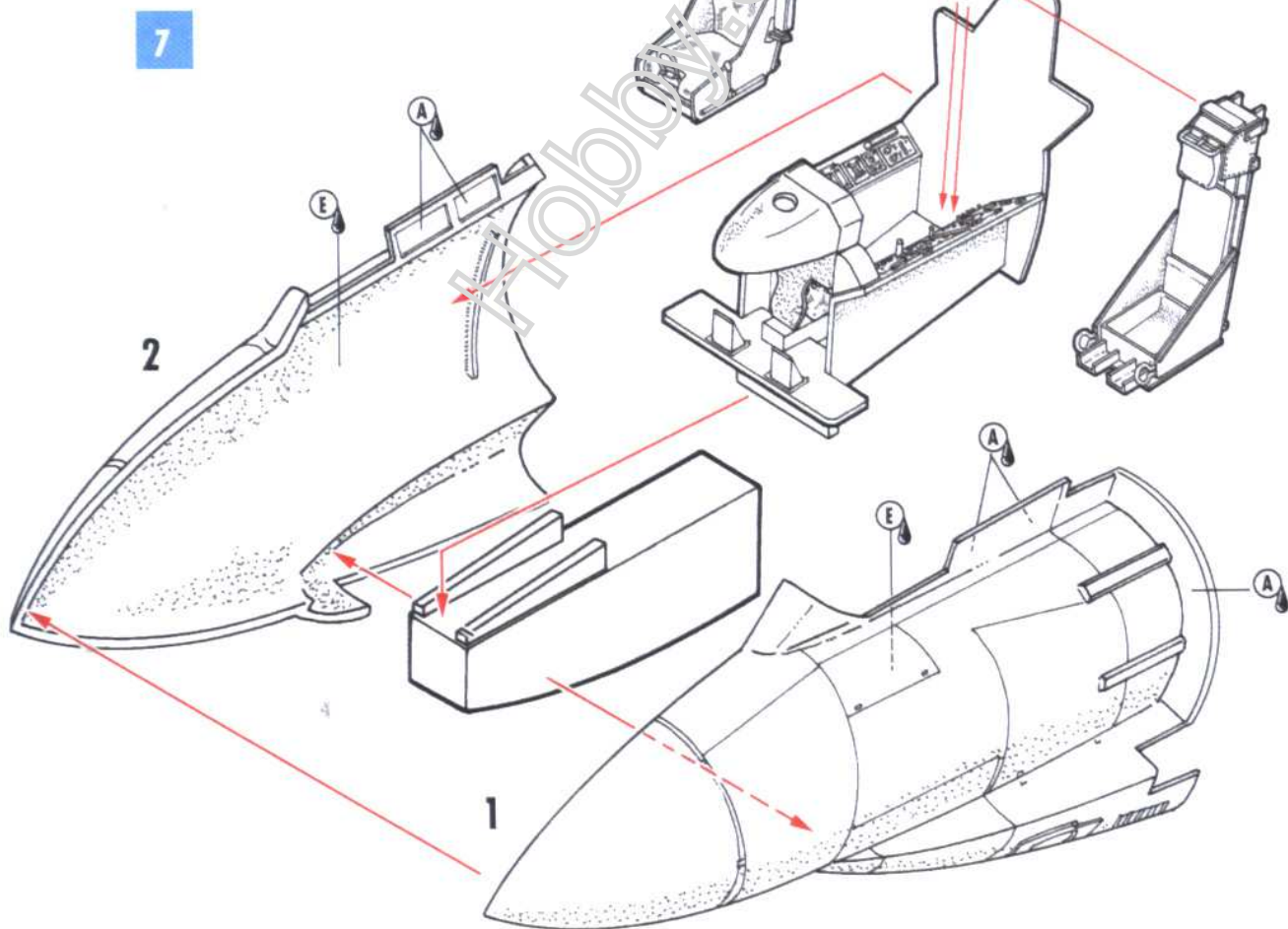
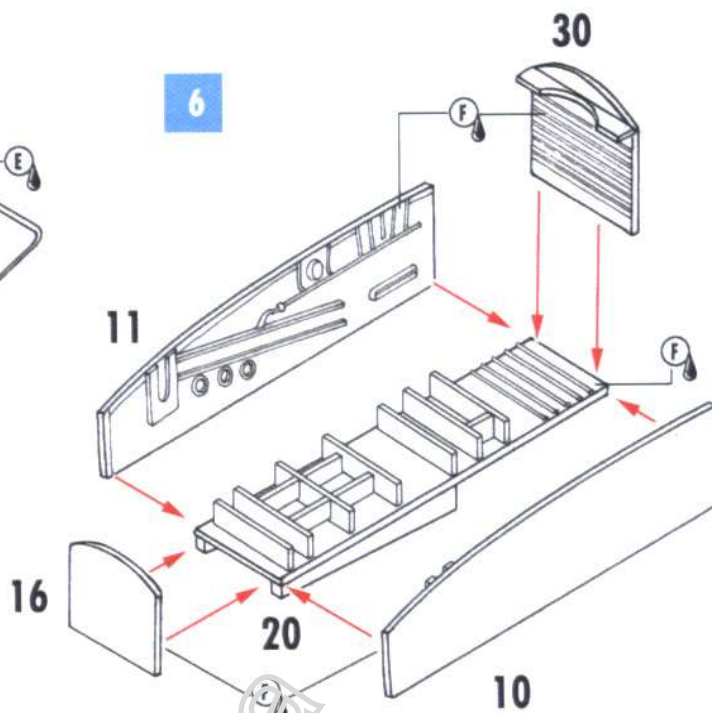
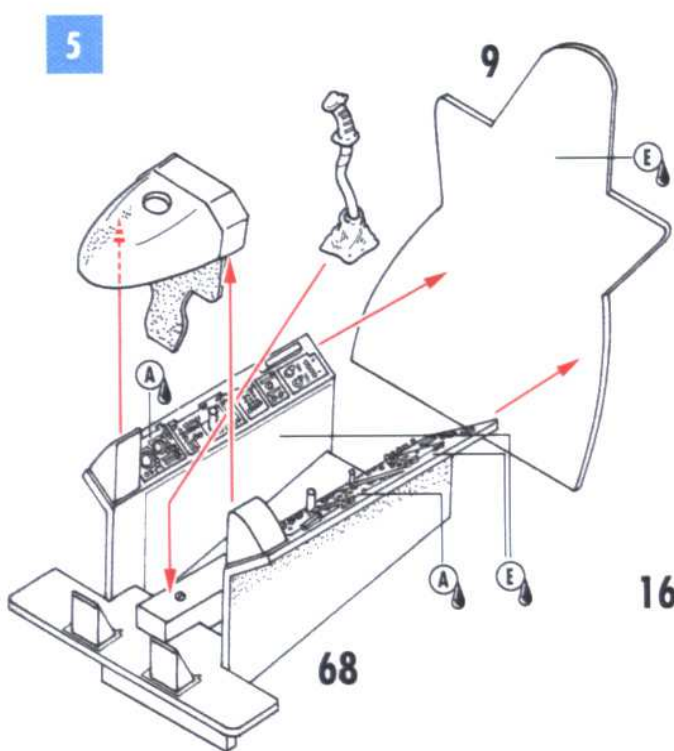

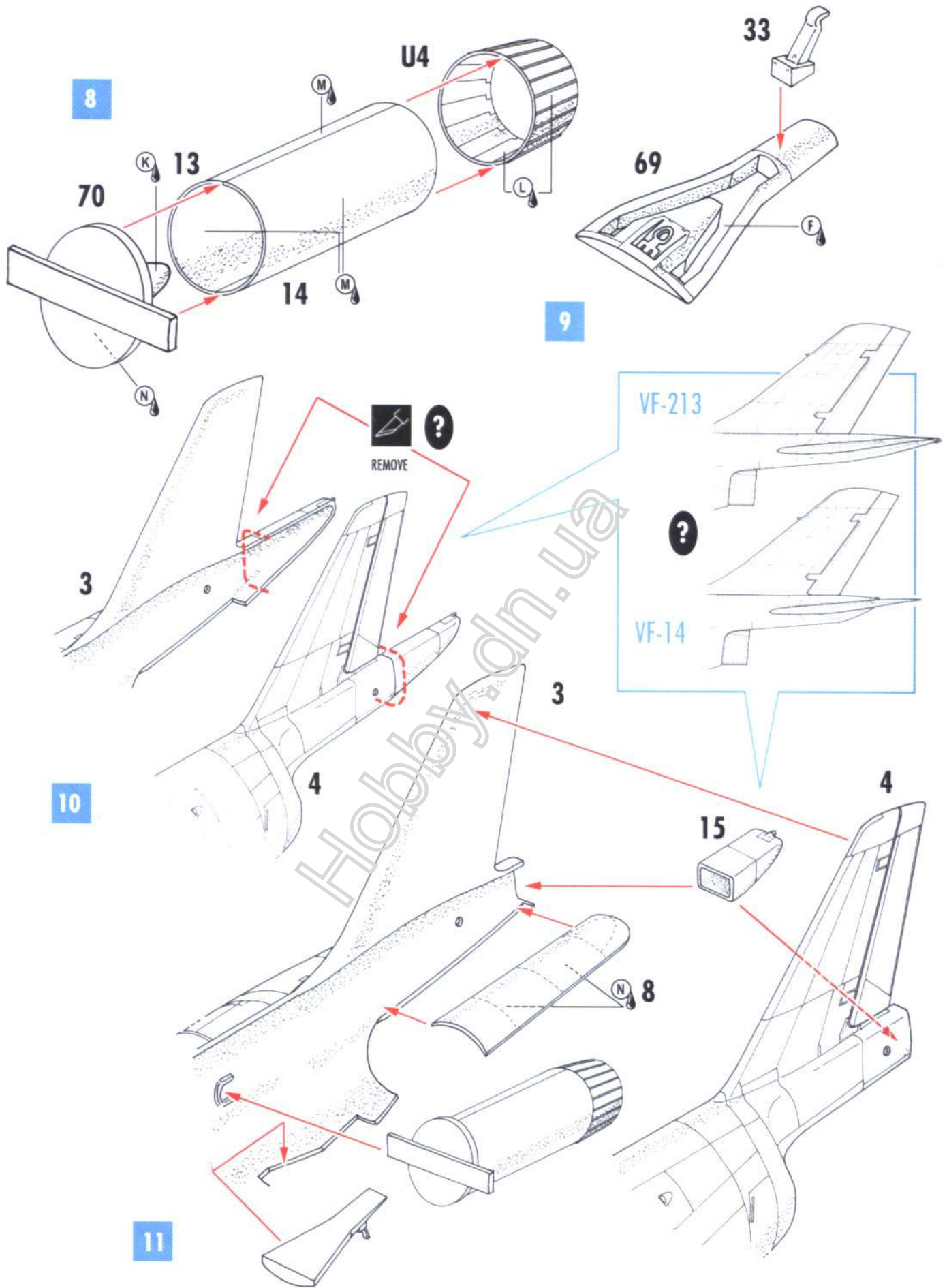

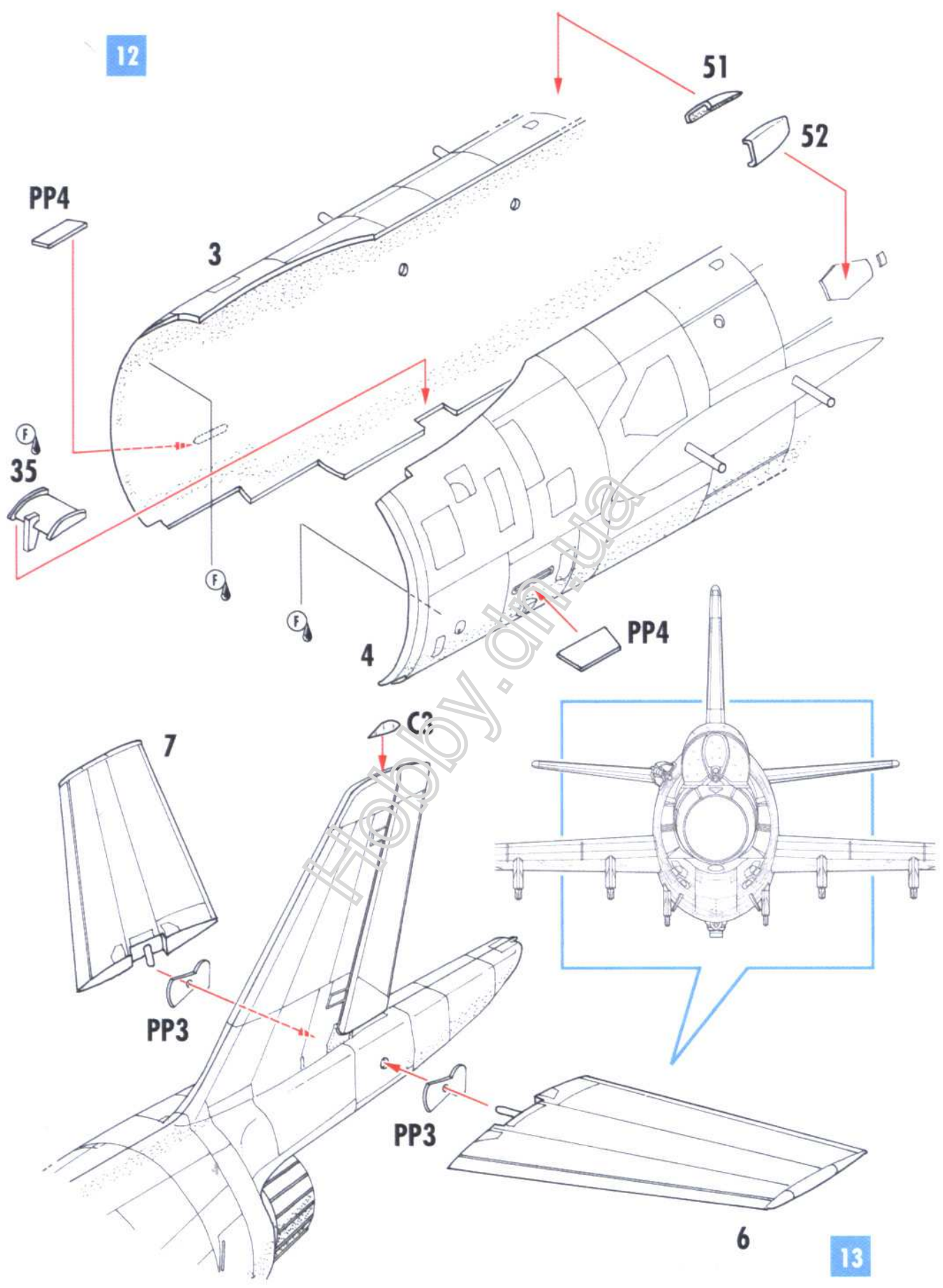

14

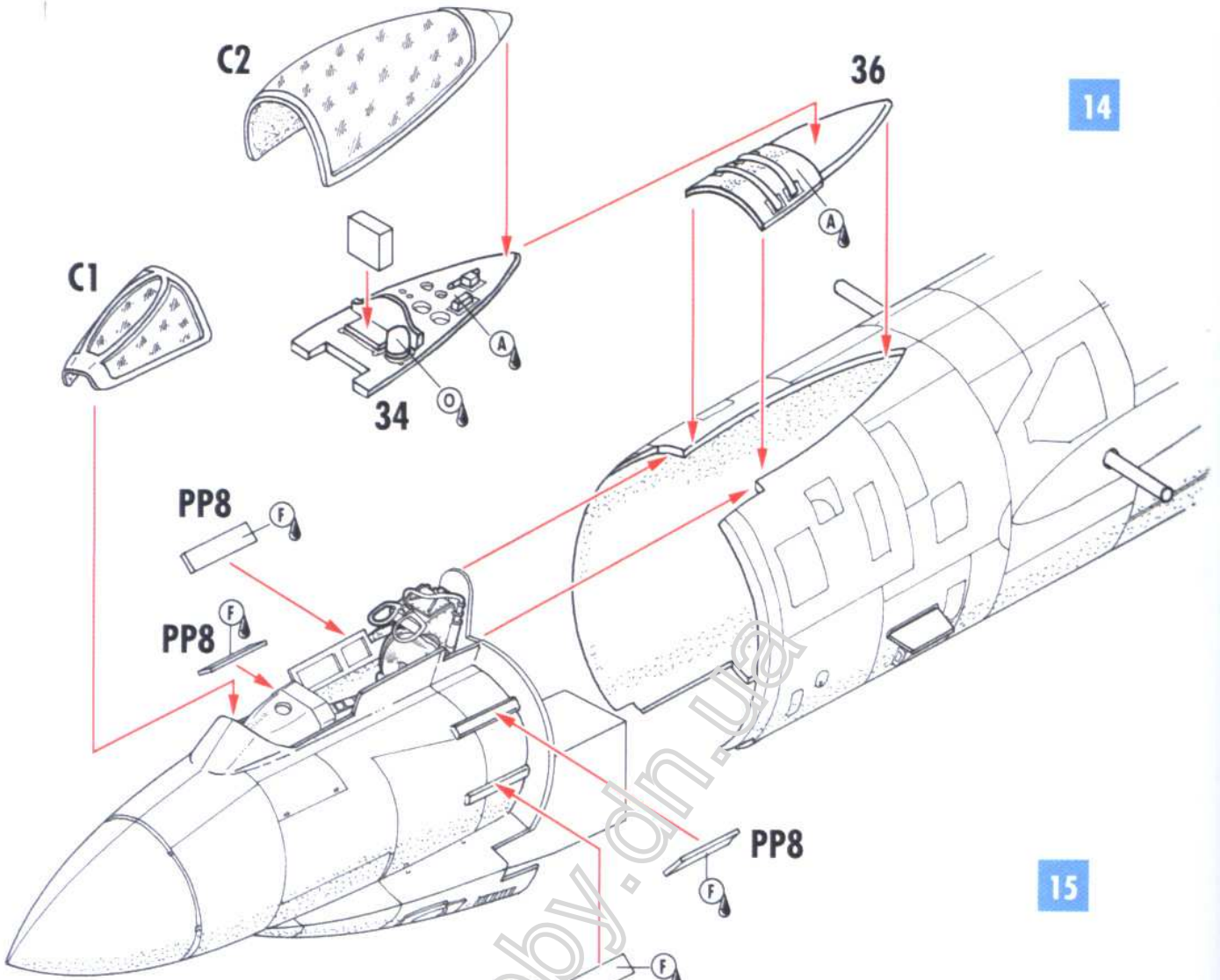

15

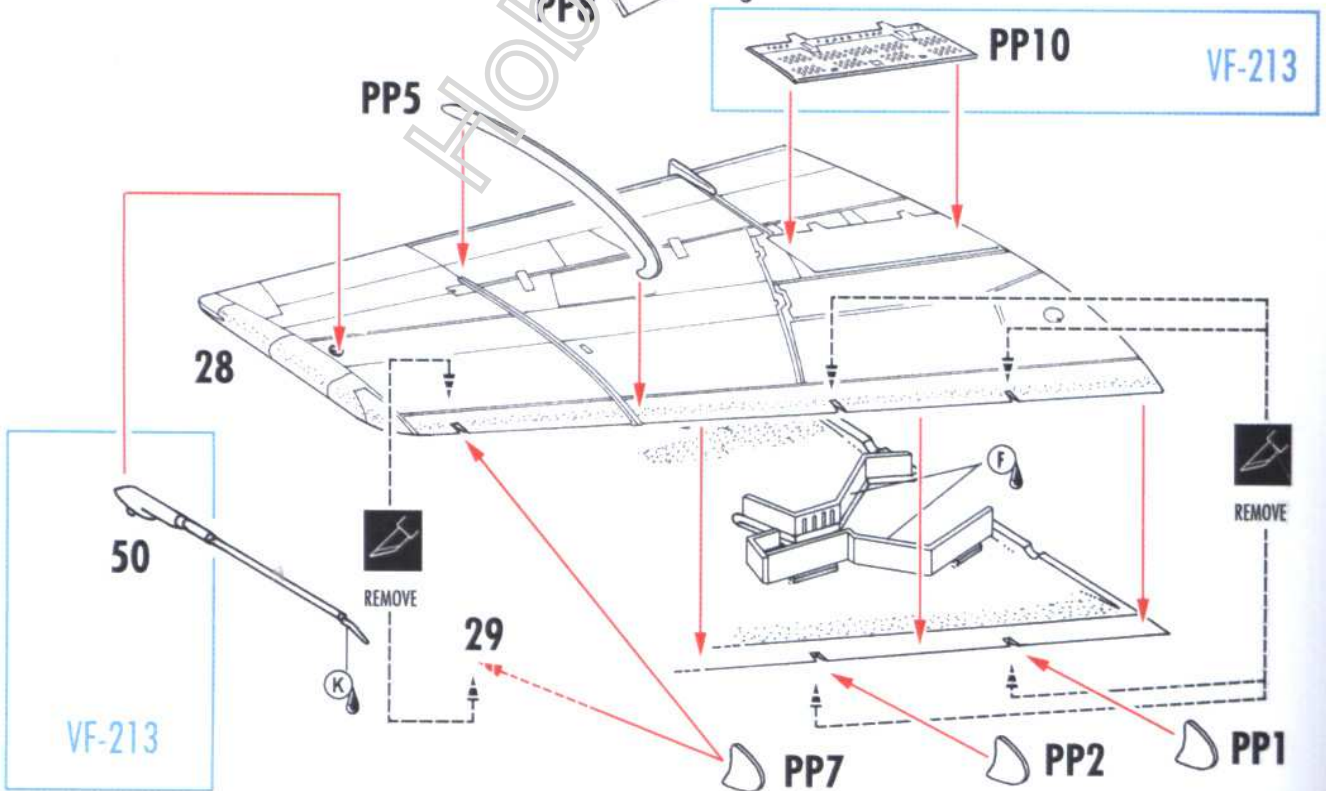

VF-213 PP9

16

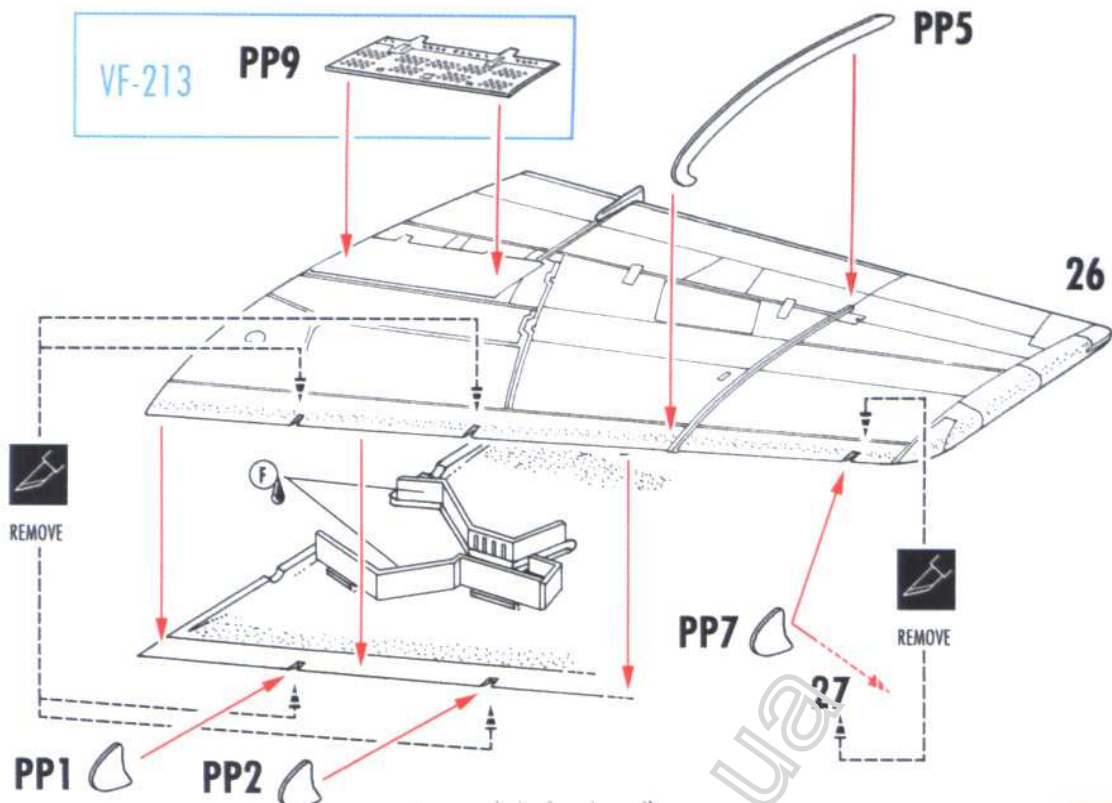

17

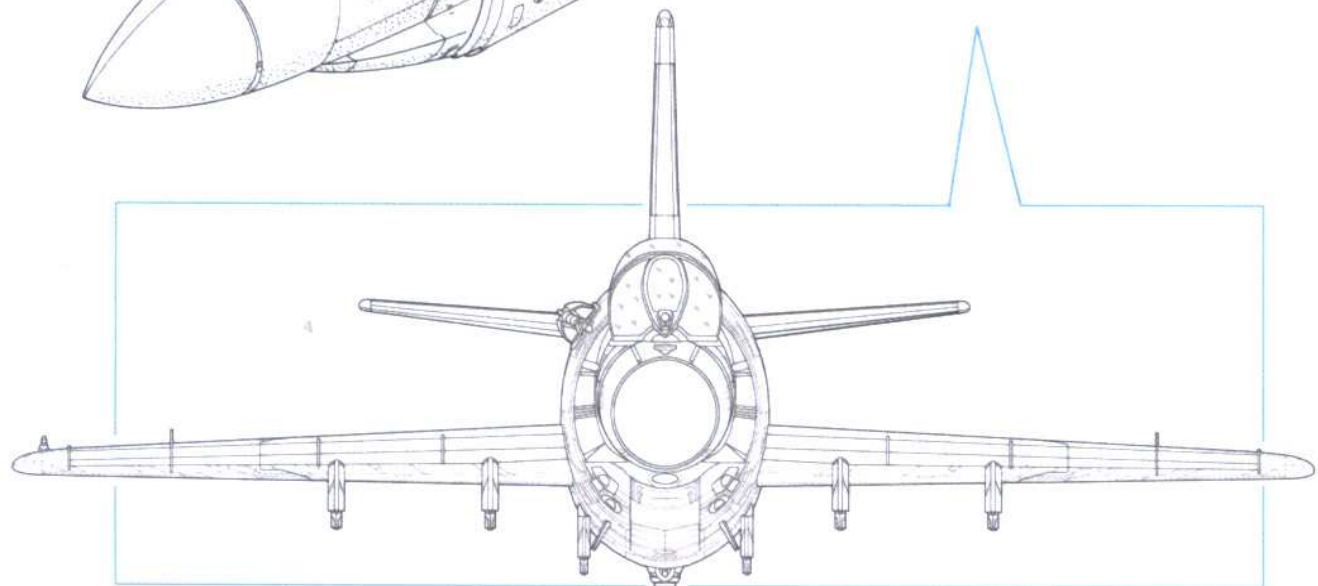
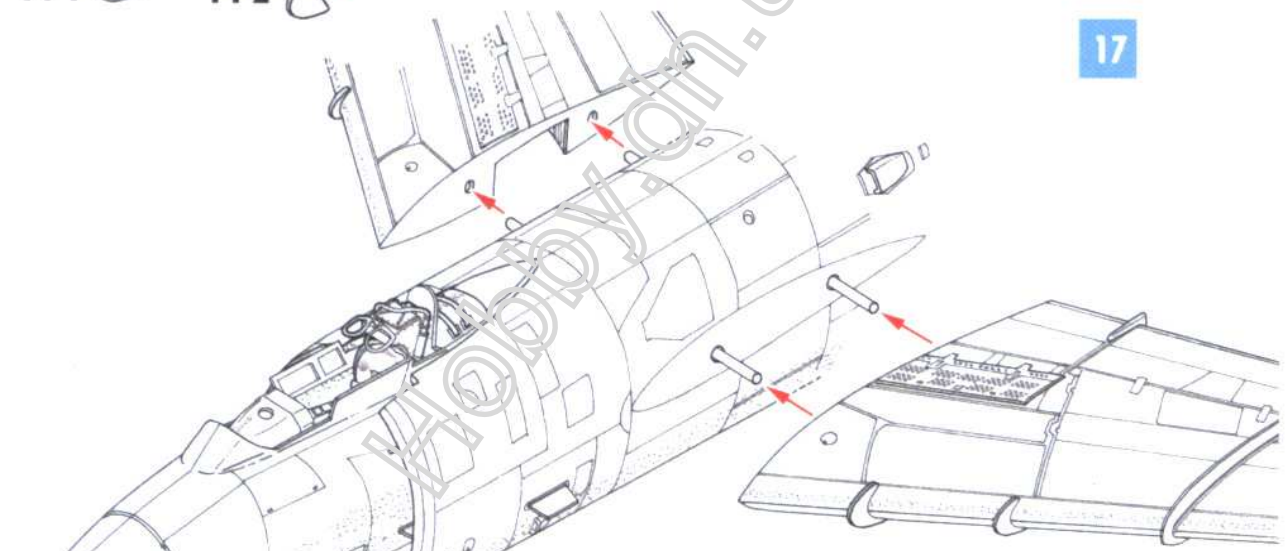

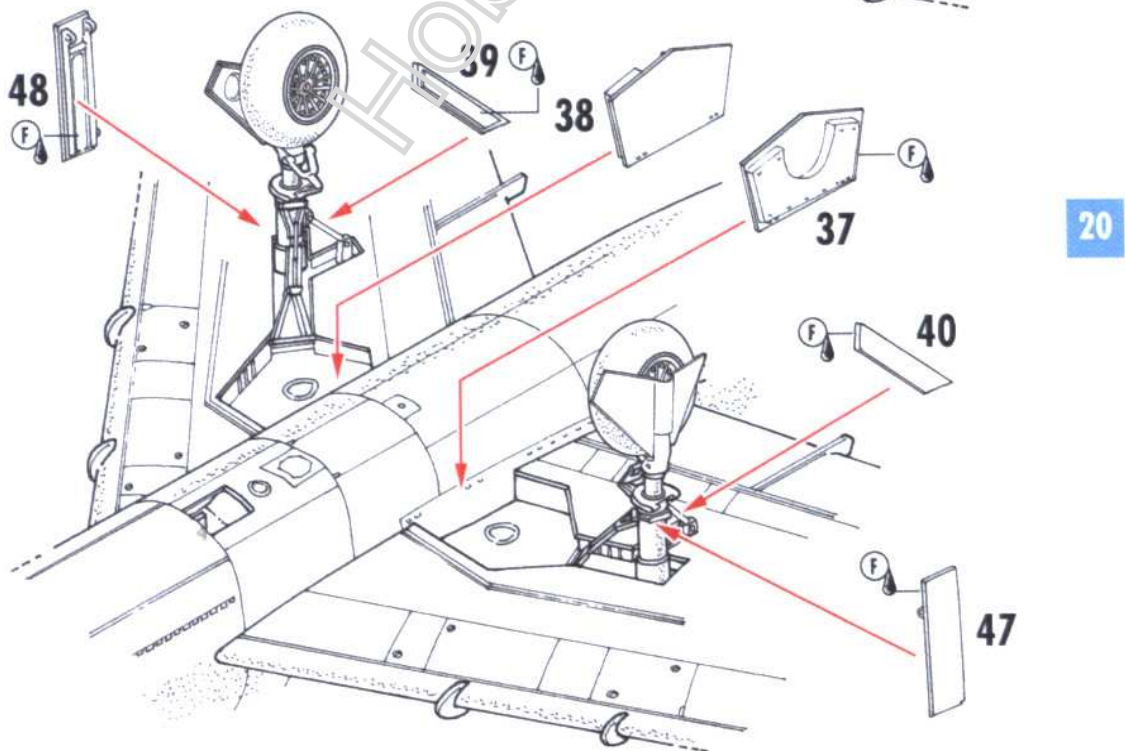
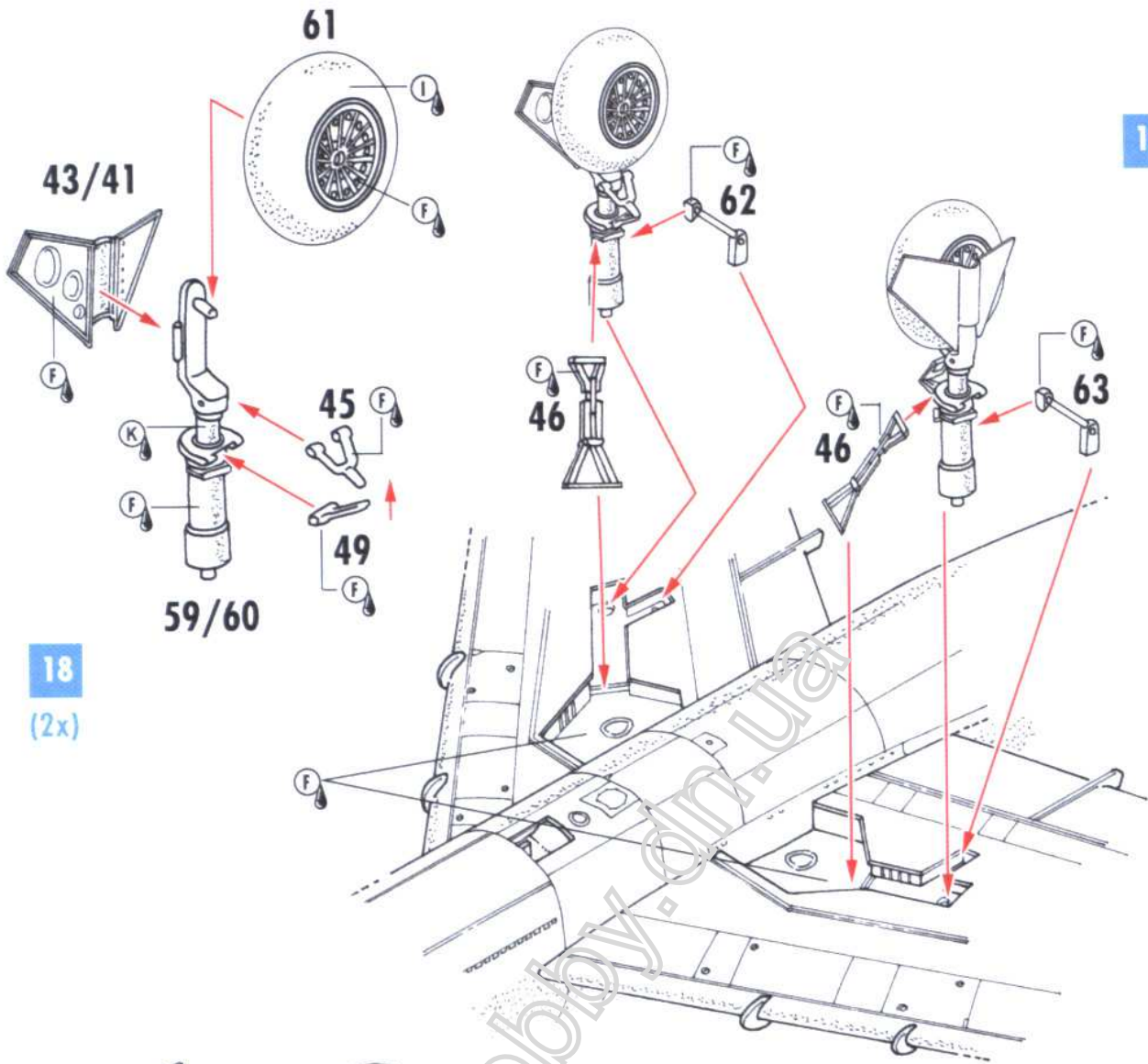

STEP 21

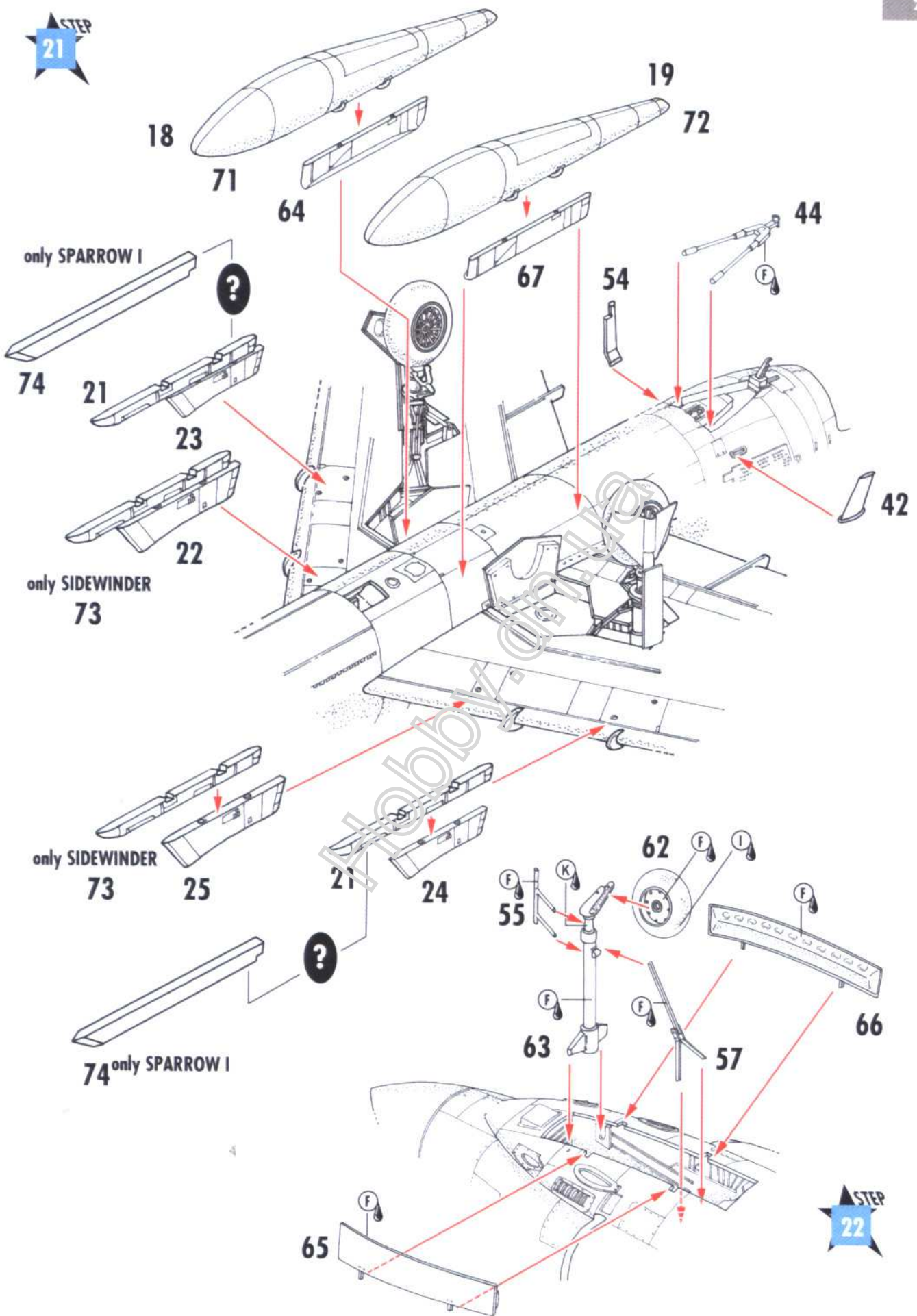

STEP 22

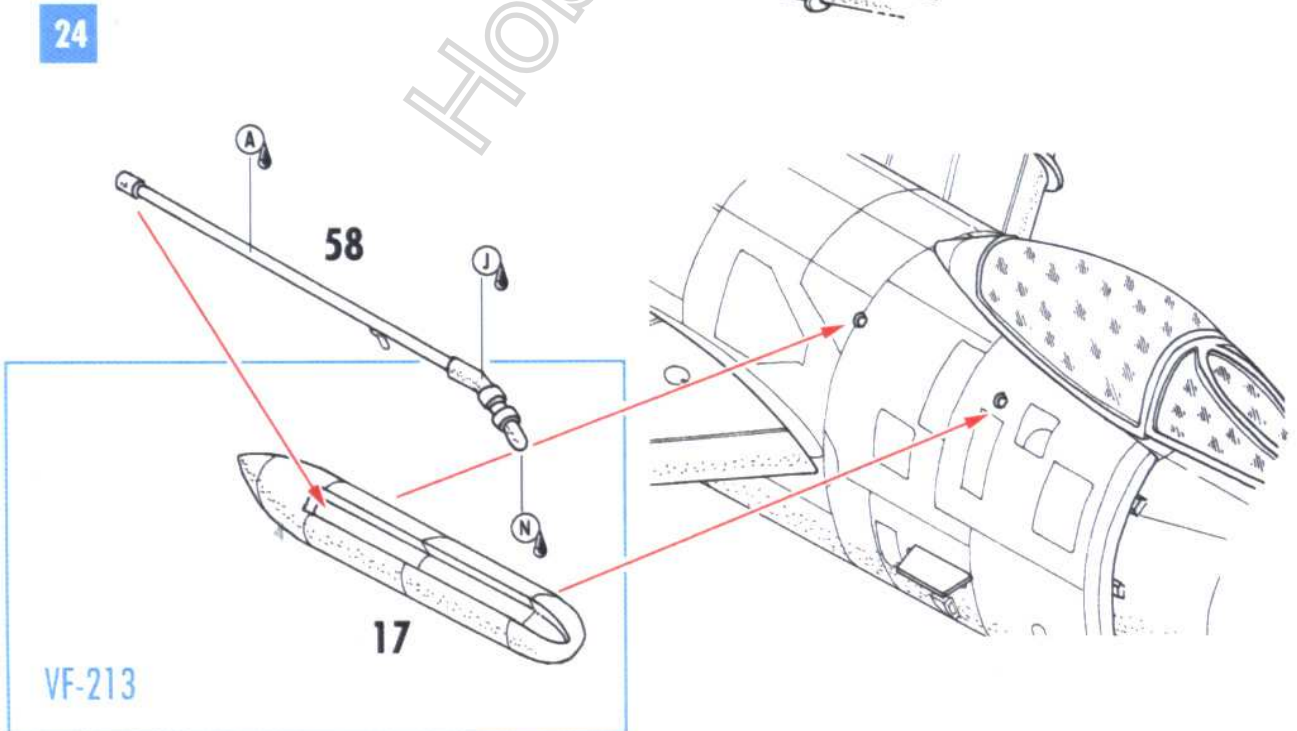
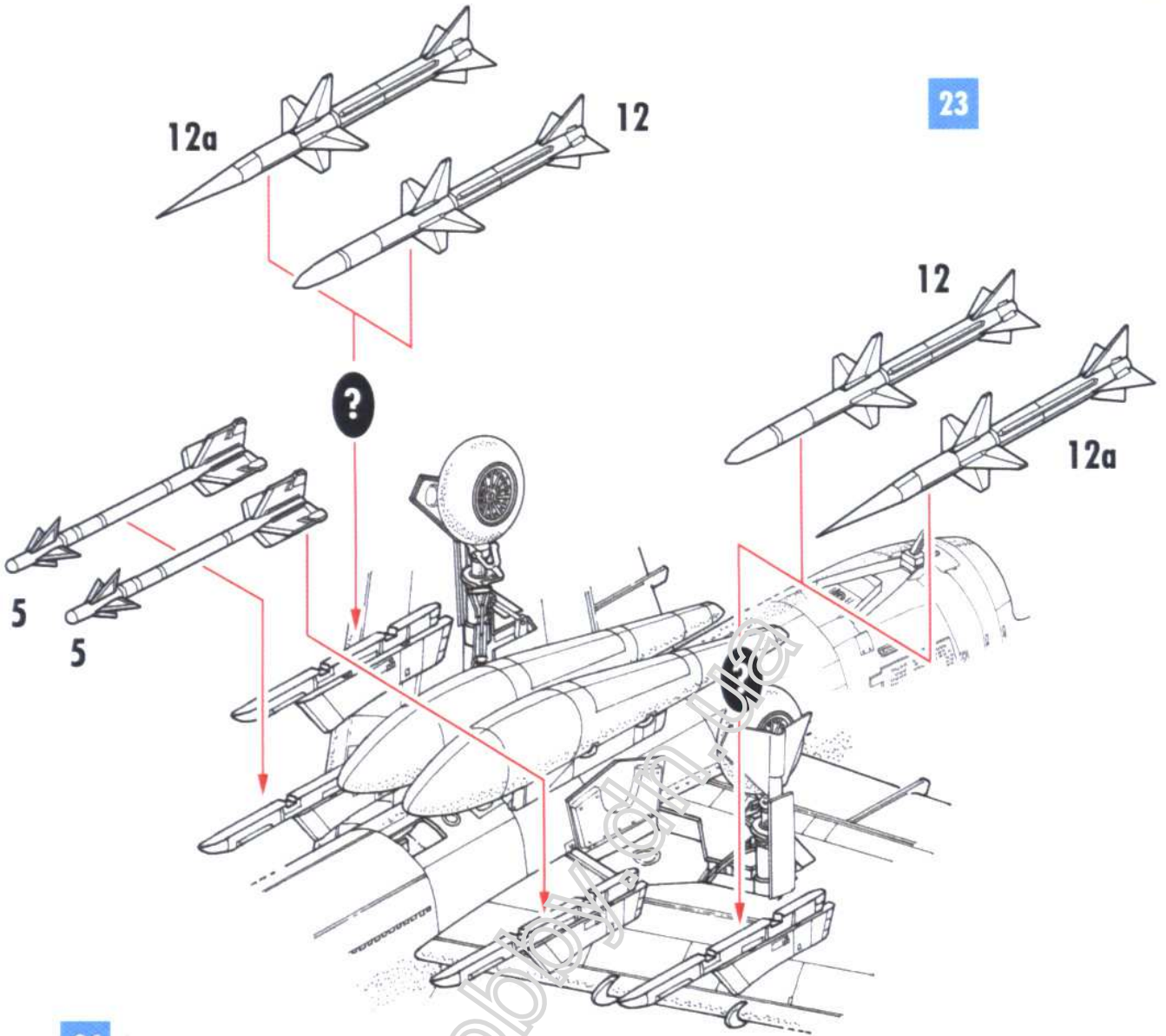

F-3B/C DEMON

F-3B Demon, VF-213, USS Hancock, May 1963

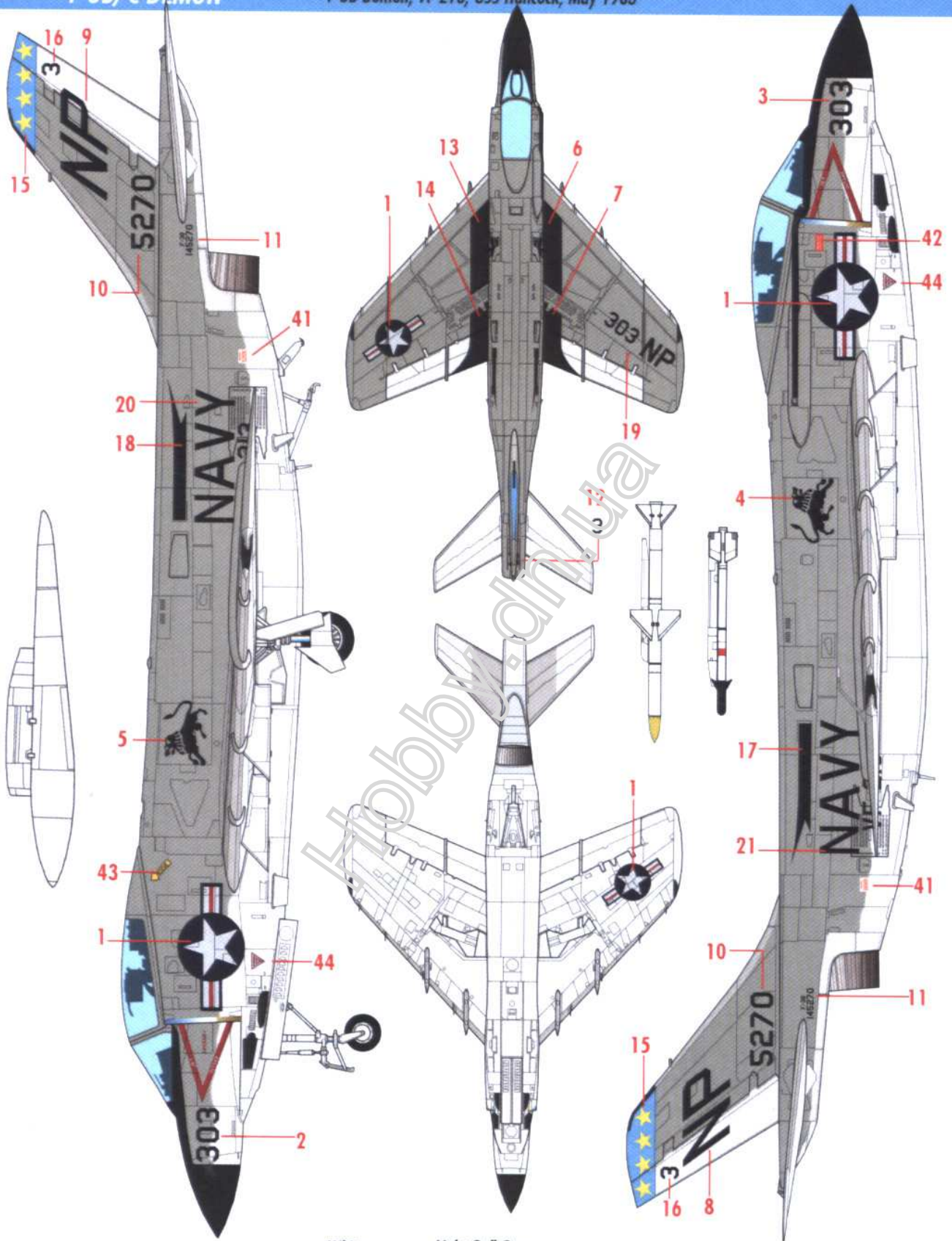

Silver



Natural metal

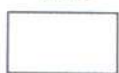

White

FS 17875

Light Gull Gray



FS 16440



Black



Light Blue

F-3B/C DEMON

F3H-2N Demon, VF-14, USS Forrestal, September 1956

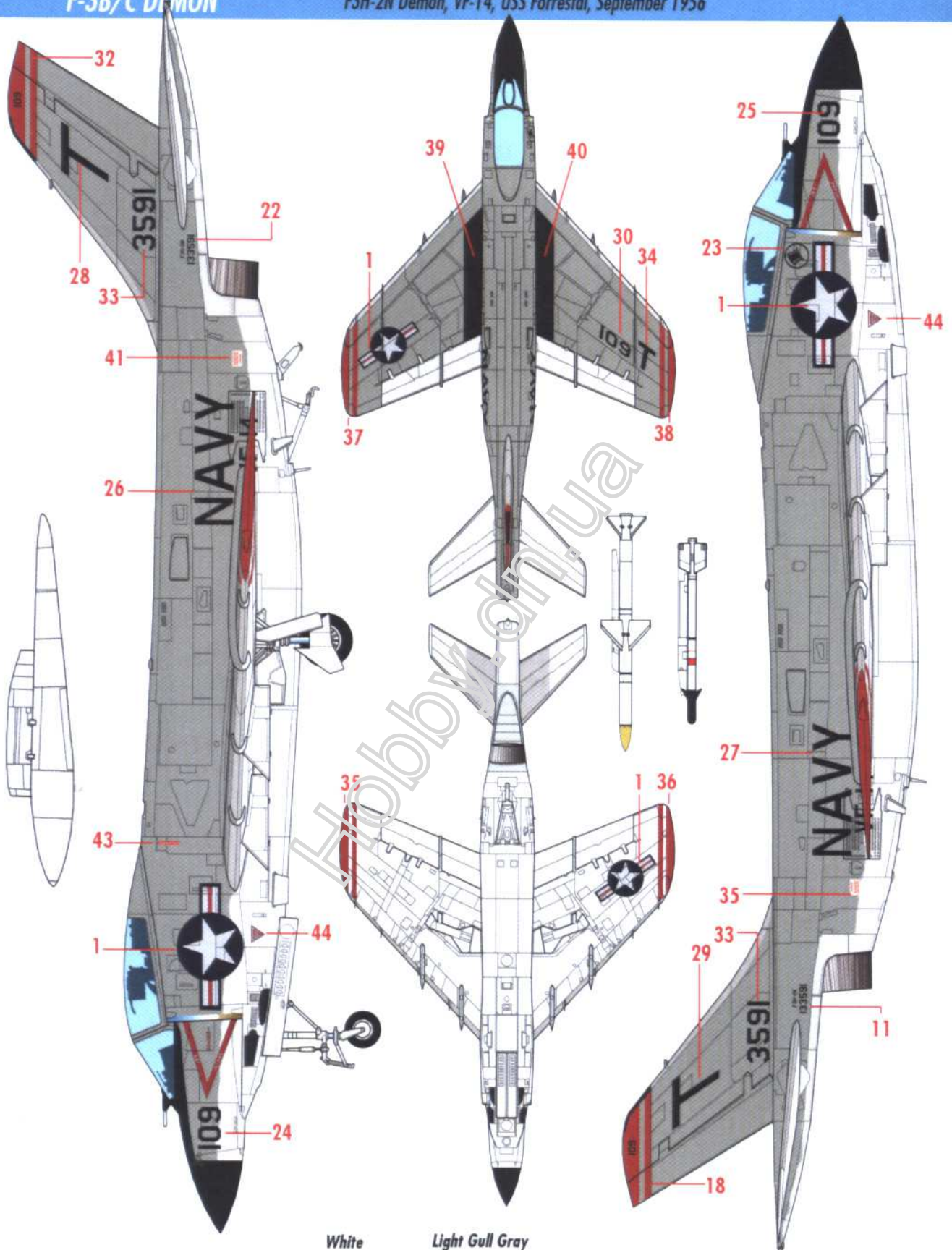

Silver

Natural metal

White
FS 17875

Light Gull Gray
FS 16440

Black

Red