

G4M1 Model 11 BETTY - Late version

SW 72148

scale 1/72

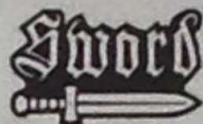

The Mitsubishi G4M was the result of a directive in 1937 from the Japanese Imperial Navy to Mitsubishi for a high-speed, long-range medium bomber, the specifications for much higher performance than existing aircraft. The official designation was Mitsubishi Navy Type 1 attack bomber. Often called 'Hannaki' ('cigar', owing to its tubular fuselage shape) by its pilots, and known as 'Betty' in the allied reporting code. First flown in October 1939, the G4M exceeded all performance requirements with a maximum speed of around 430kmh / 265 mph / 230 kts at 4200m or 13380ft, cruise speed of 315kmh / 195 mph / 170kts at 3000m / 9850ft, and a normal range of 2850km / 1770 miles. It had a ferry range of over 5000km / 3100 miles. The aircraft was light and fast but at the expense of having no armour or self-sealing fuel tanks until the G4M3 versions. There were continual up-grades of power-plant. It had a crew of seven including a pilot, co-pilot, navigator / bombardier / nose gunner, top turret gunner, radio operator / waist gunner, mechanic / waist gunner, and tail gunner. The tail gun being a 20mm cannon, all other machine guns being 7.7mm / .303 cal. The aircraft could carry 1 x 858kg / 1892lb bomb, a similar weight aerial torpedo, or 4 x 250kg / 550lb bombs. Late in WWII it would carry Yokosuka MXY7 Ohka rocket powered, pilot-guided (Sakurahanna – Sakura Blossom / Cherry Blossom) suicide (Kamikaze) flying-bombs. G4M aircraft saw combat in China, the Pacific as far north as the Aleution Islands, as far south as the Northern Territories of Australia. G4M1 variants were modified as long-range bomber escorts, and other variants included transport and heavy trainers. Some G4M carried anti-shiping radar. JIN Admiral Yamamoto was killed when the G4M he was travelling in was shot down by P38s in April 1943. In the same battle, JIN Chief of Staff, Vice-Admiral Matome Ugaki was also shot down in a G4M, but survived. Two G4Ms painted white, with green insignia crosses, carried Japanese surrender delegations on the first leg of travel to Manila.

SWORDMODELS s.r.o. Tešínská 288
739 34 Šenov
CZECH REPUBLIC

www.swordmodel.cz
e-mail: swordmodels@gmail.com

WHITE	BLACK	GUN METAL	ALUMINIUM	INTERIOR GREEN	RED	YELLOW	BROWN	BURNT IRON	CHROME	GREY	TIRE BLACK	BLUE
A	B	C	D	E	F	G	H	I	J	K	L	M
C1	C33	C104 XF-56	C8	C126	C47	C4	C42 XF-10	C61	MC211 X-11	C35	C137	C50
STEEL	C - Mr.COLOR XF, X - TAMIYA				REMOVE	BEND	OPEN HOLE	SCRATCH BUILD	SYMETRICAL ASSEMBLY	OPTION		
N												
C28												

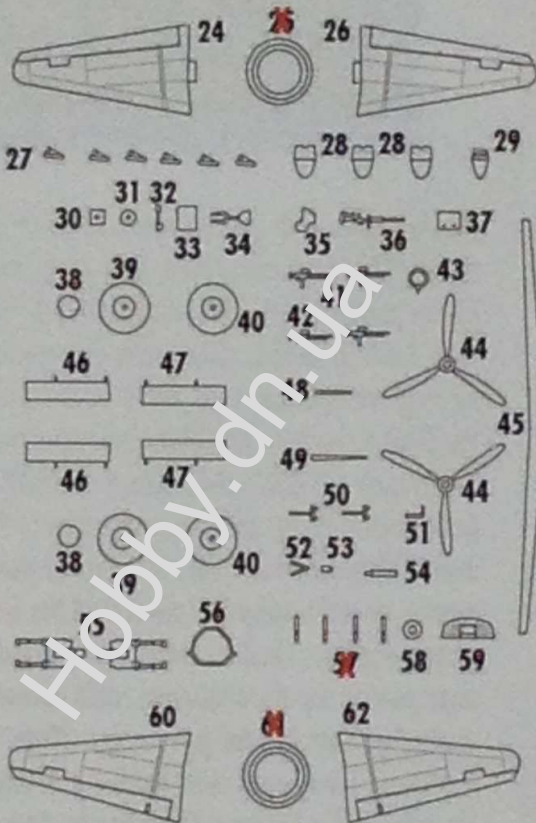
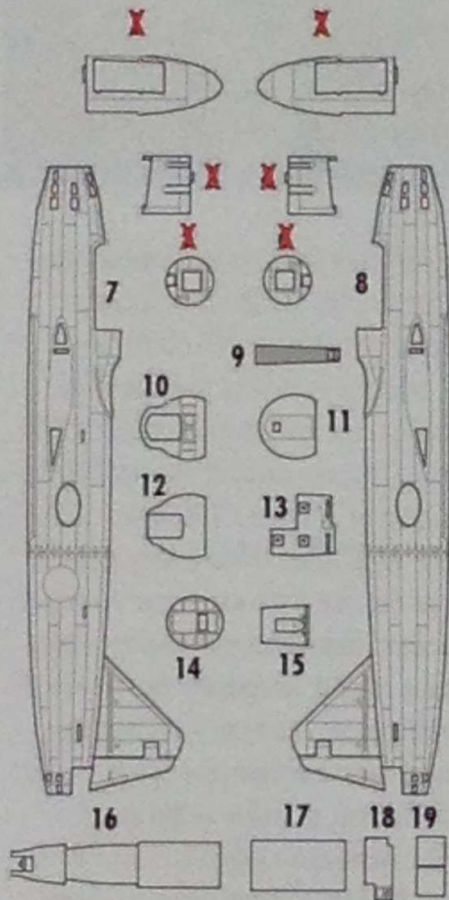

CLEAR PART

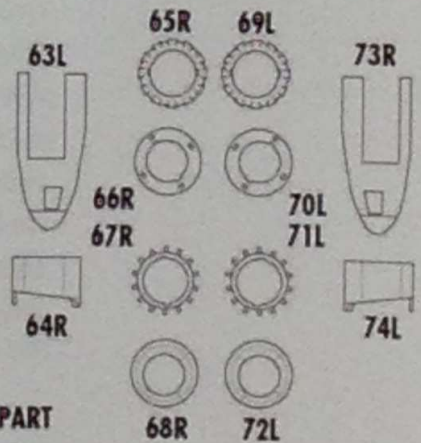
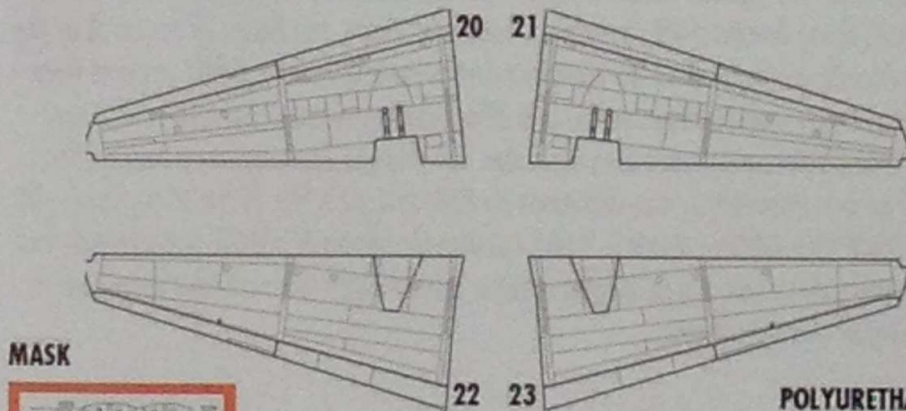
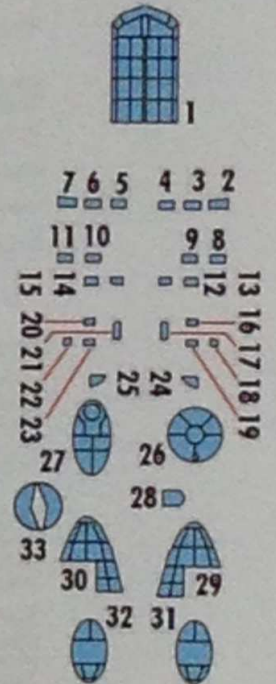

MASK

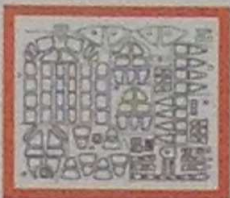

POLYURETHAN PART



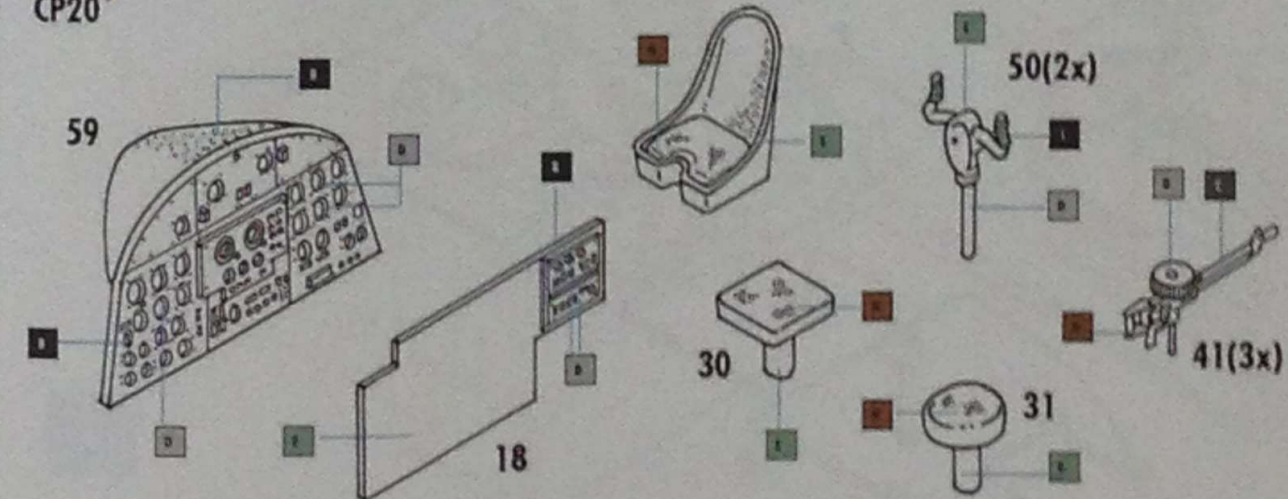
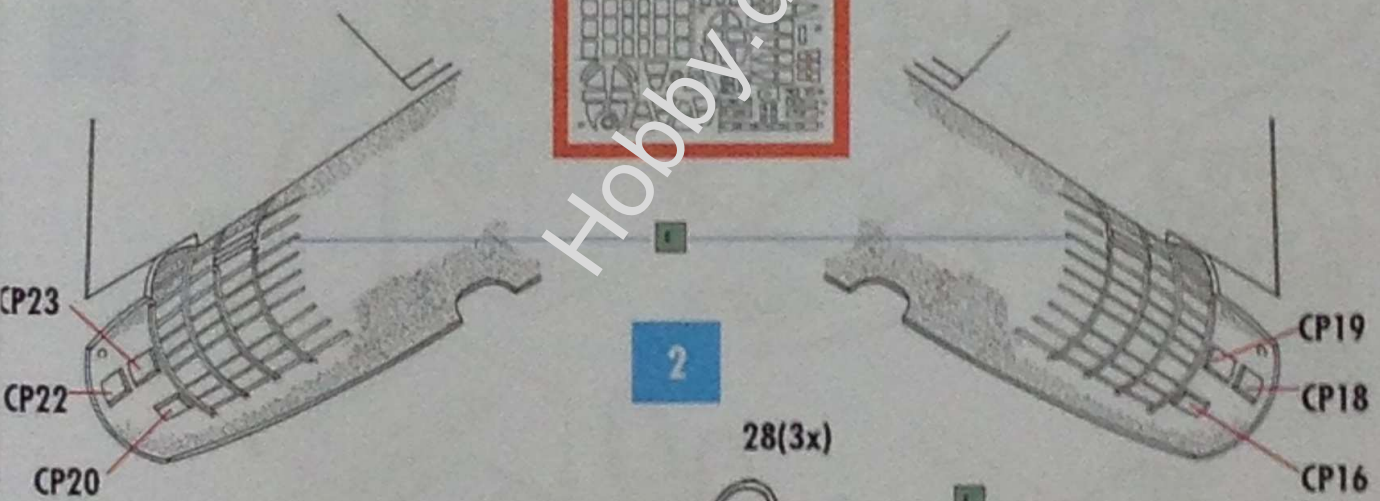
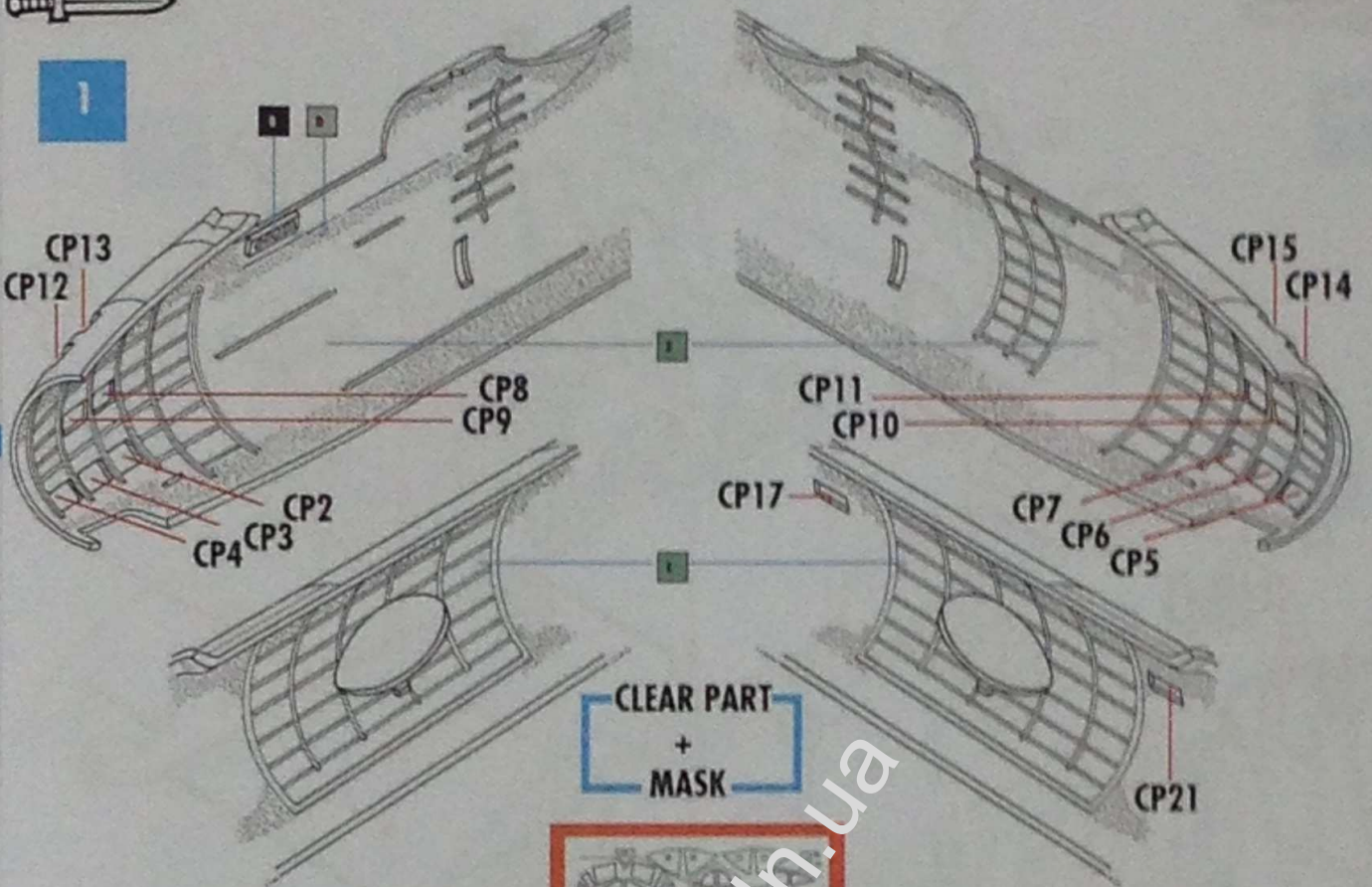

3

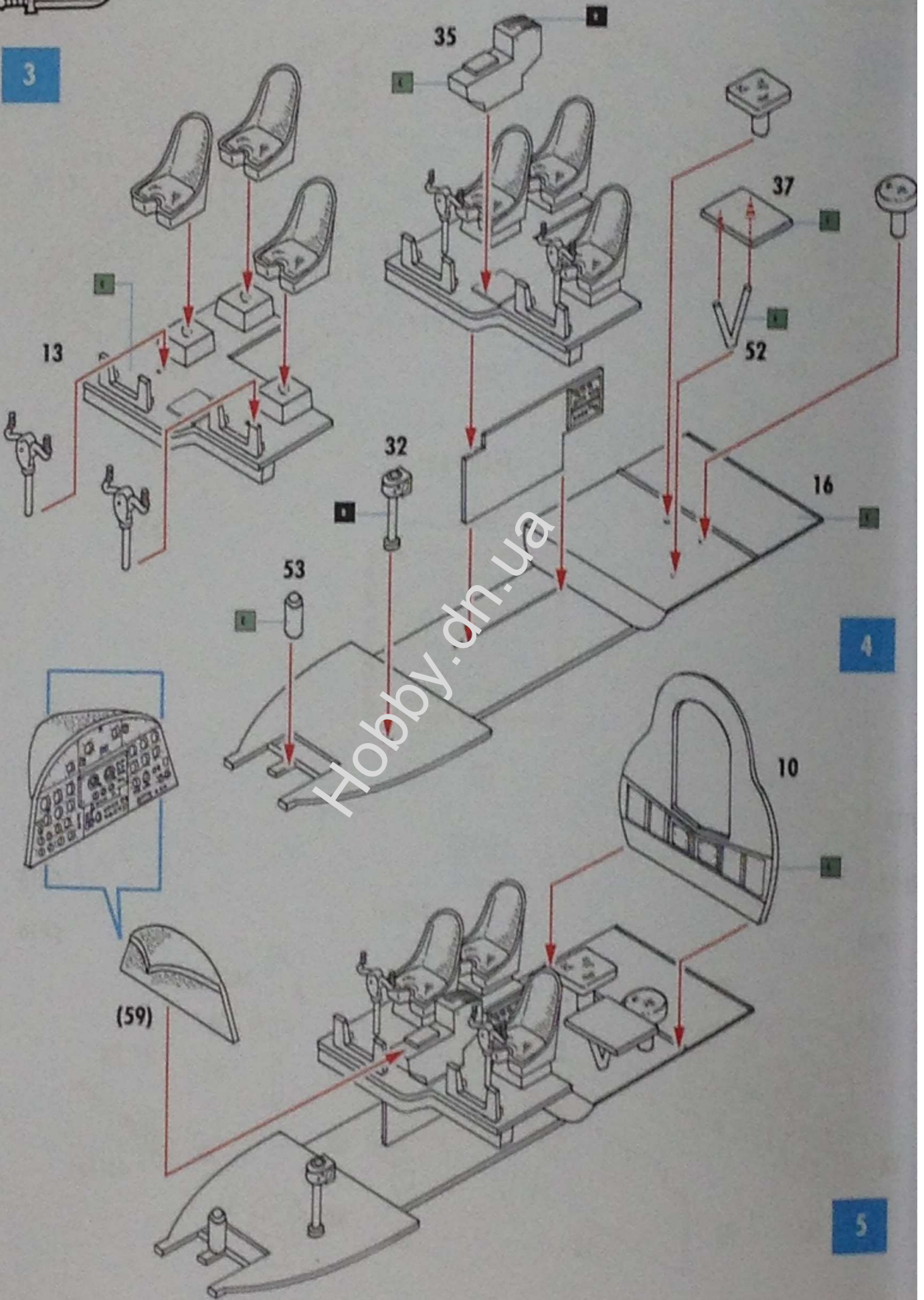

4

5

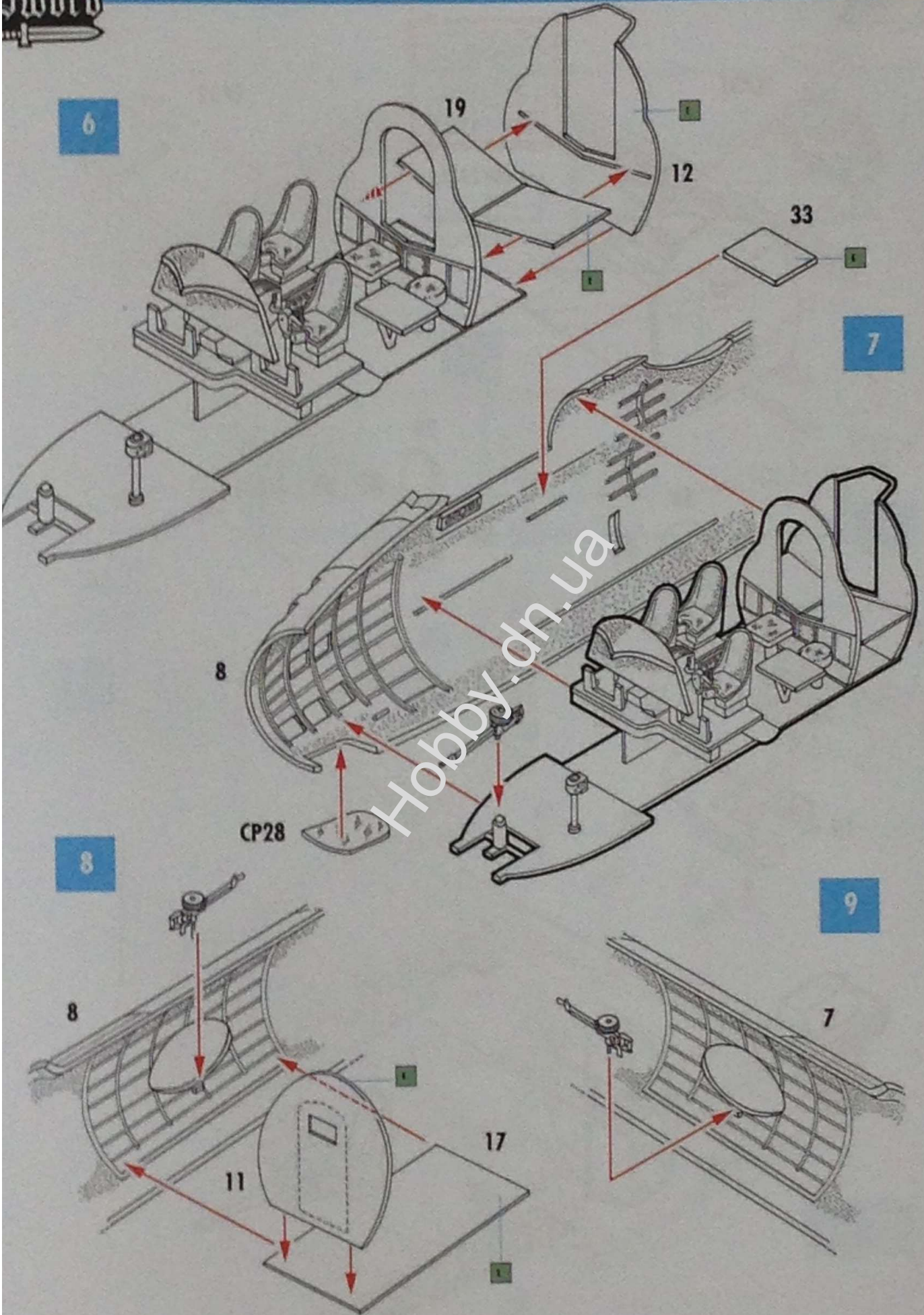

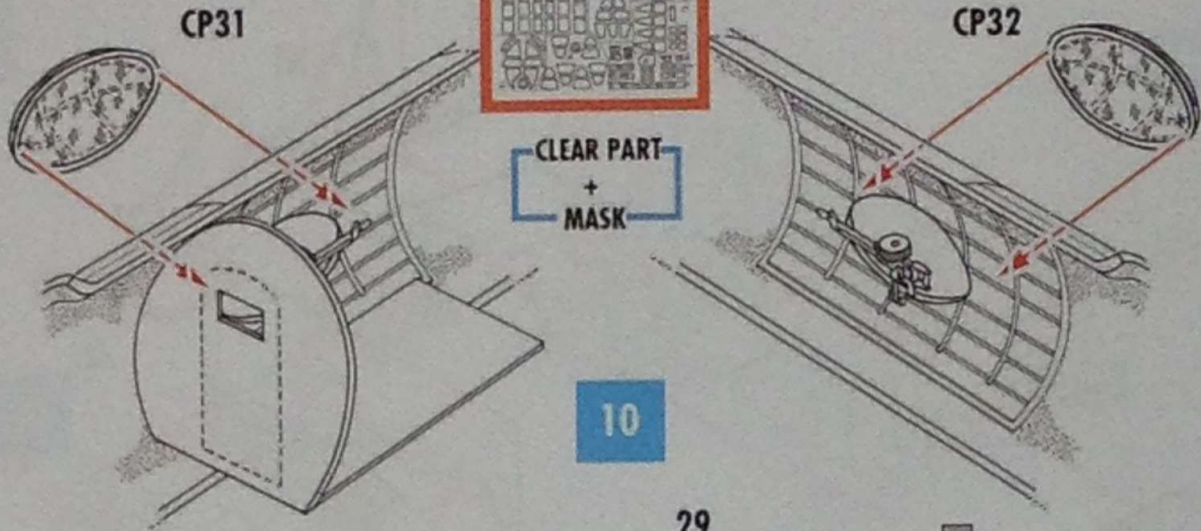

11

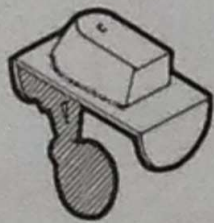
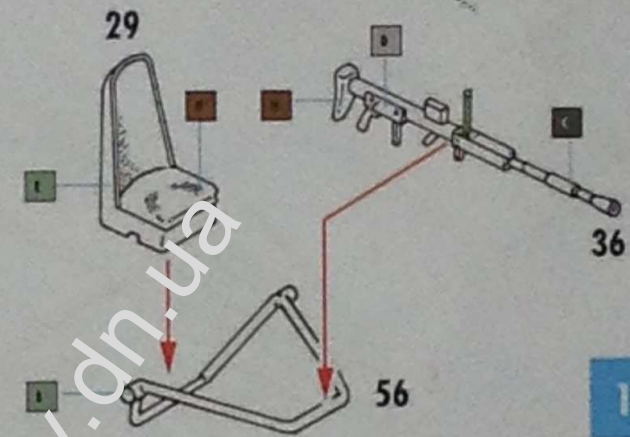

13

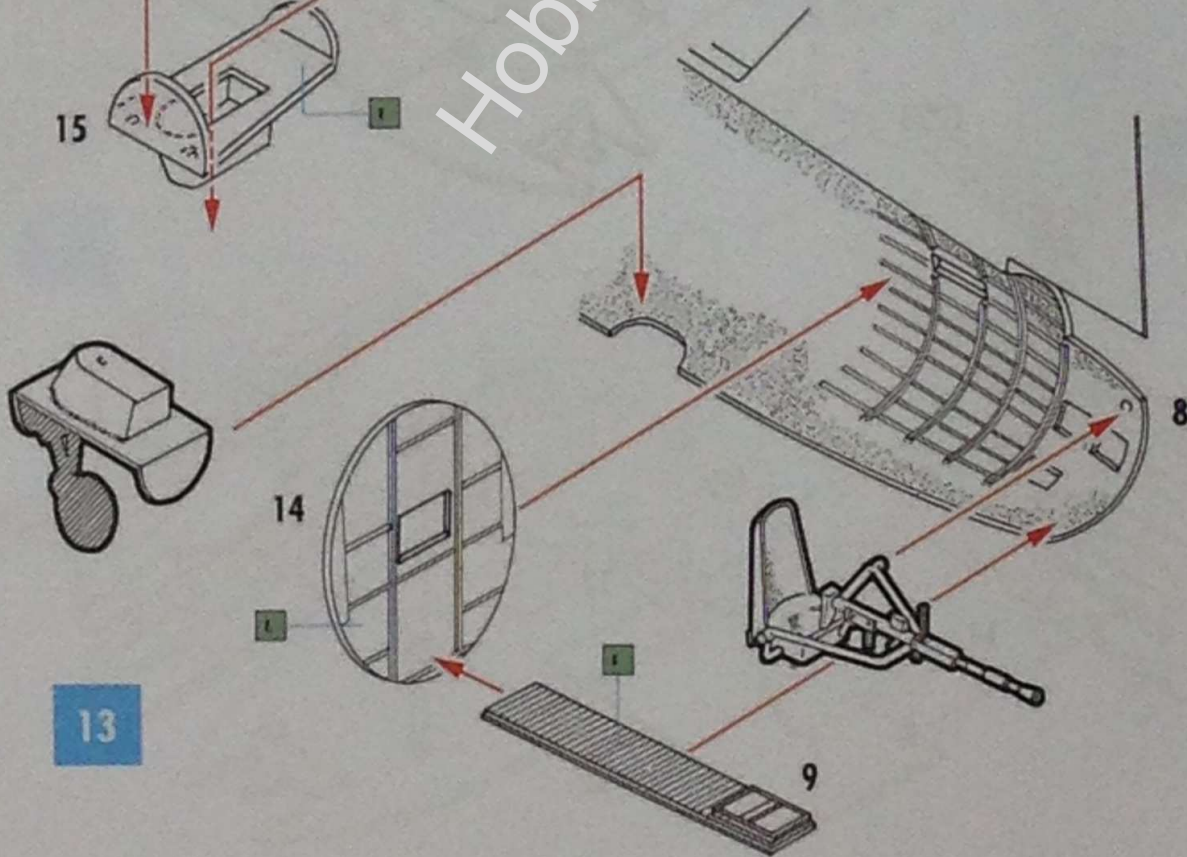
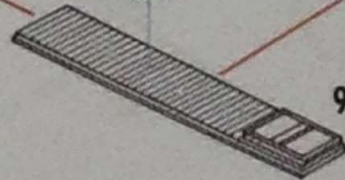
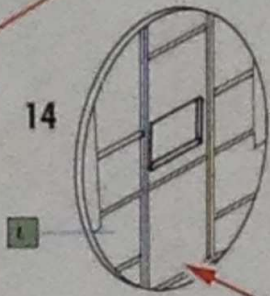

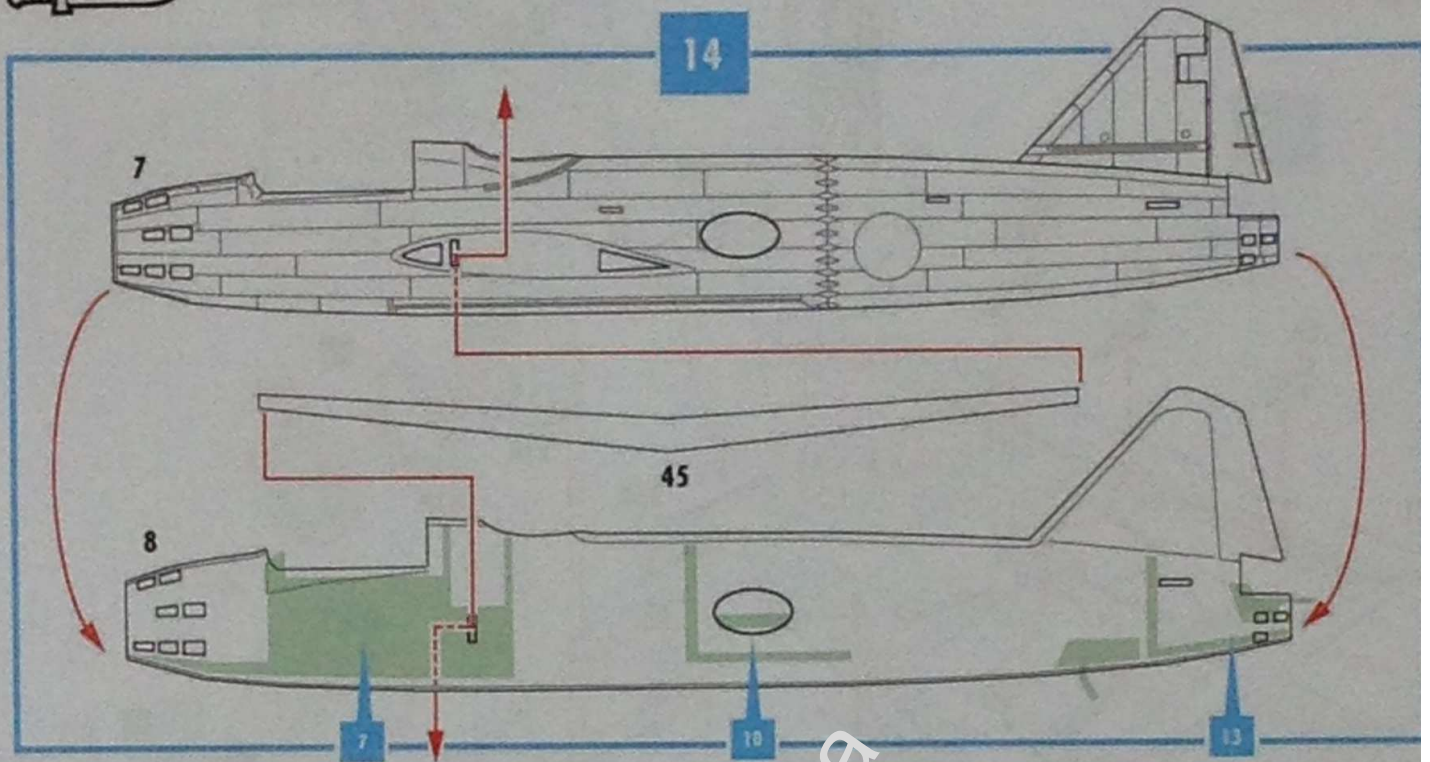

15

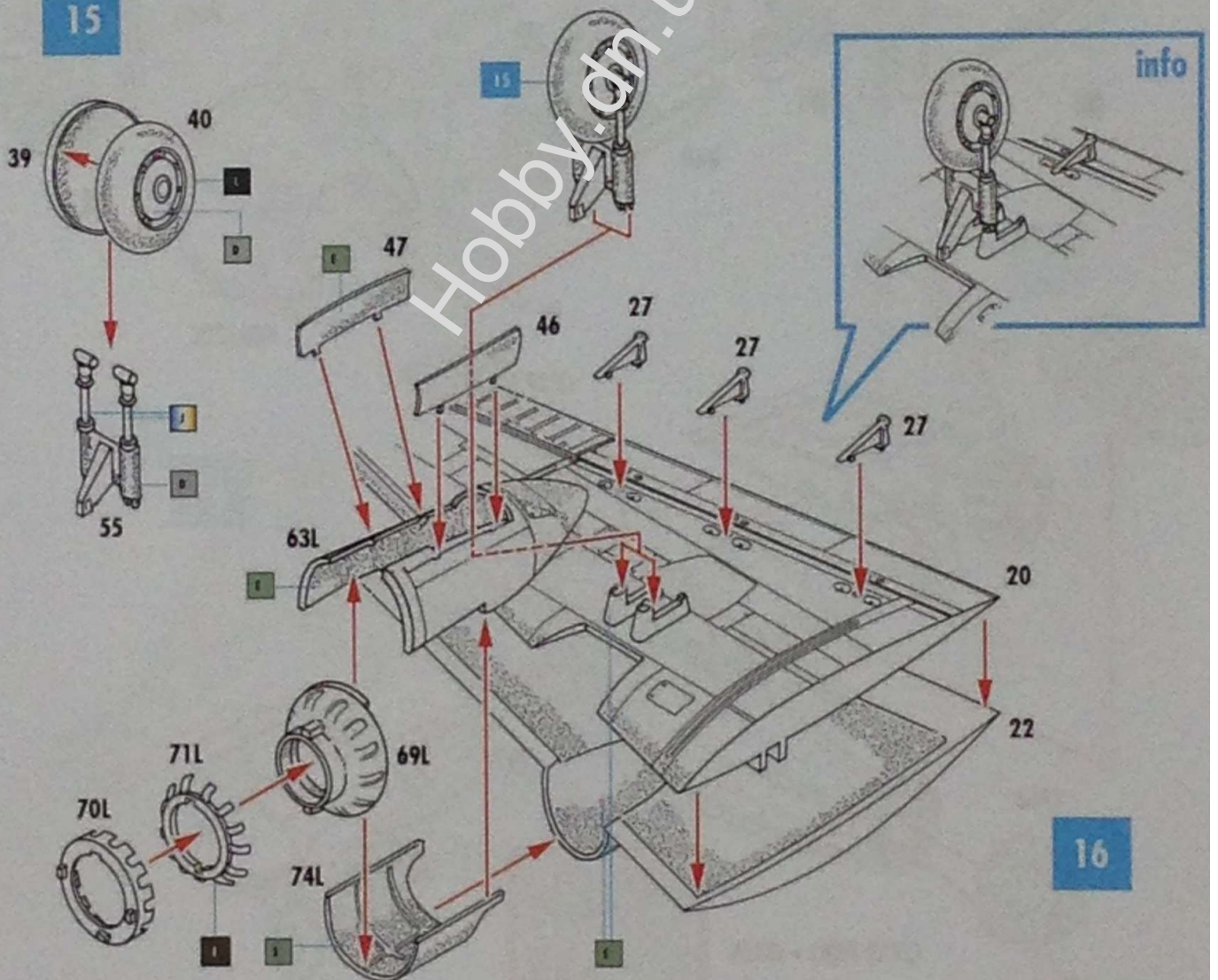

17

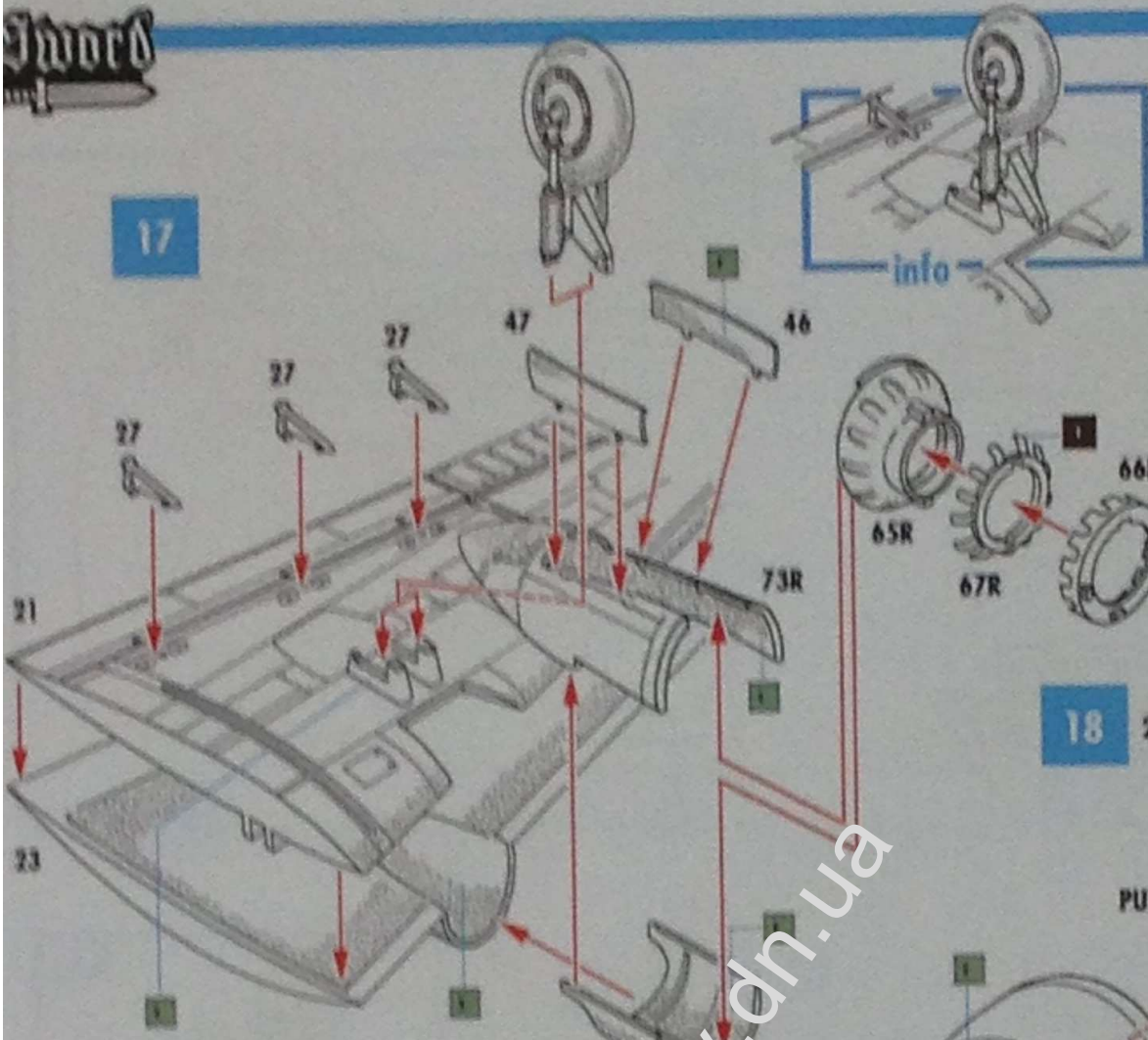

18

2x



Hobby.dn.ua

19

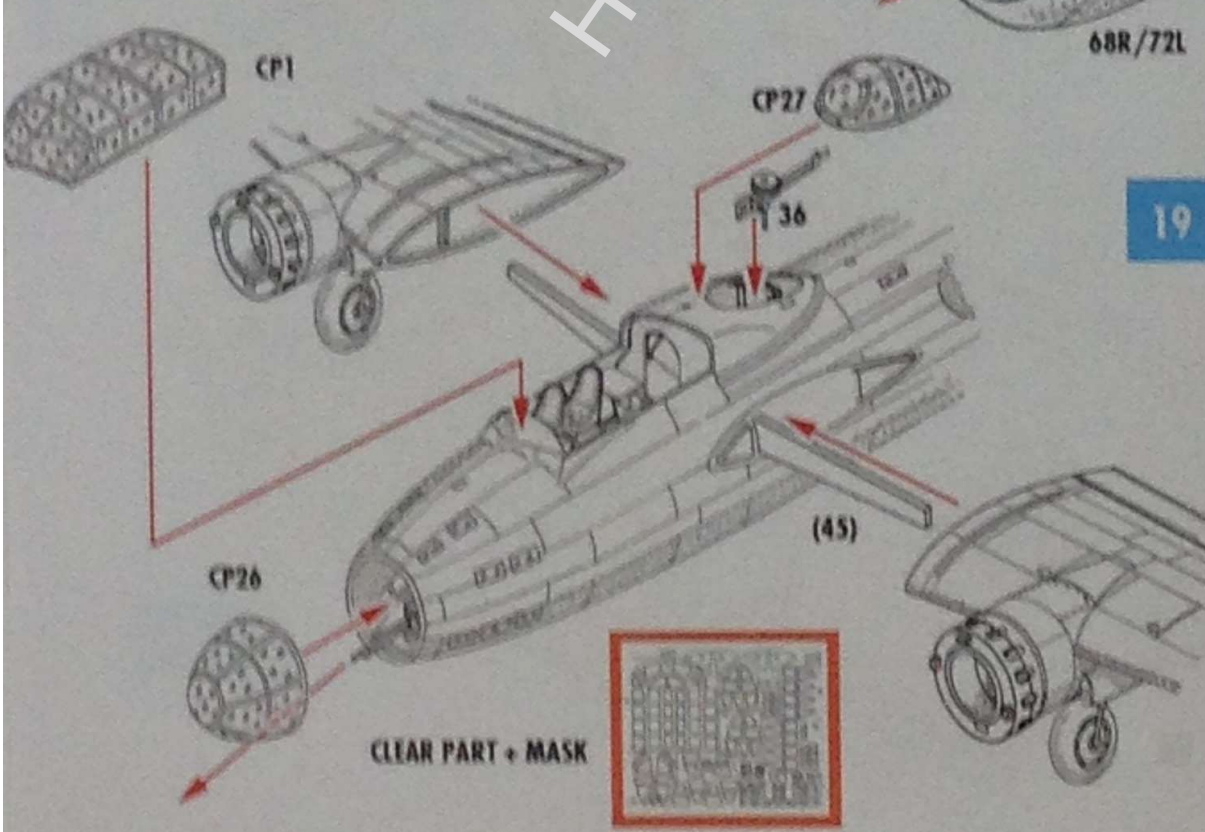

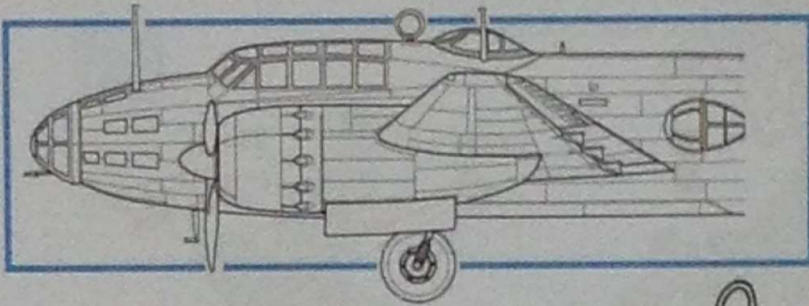

info

20

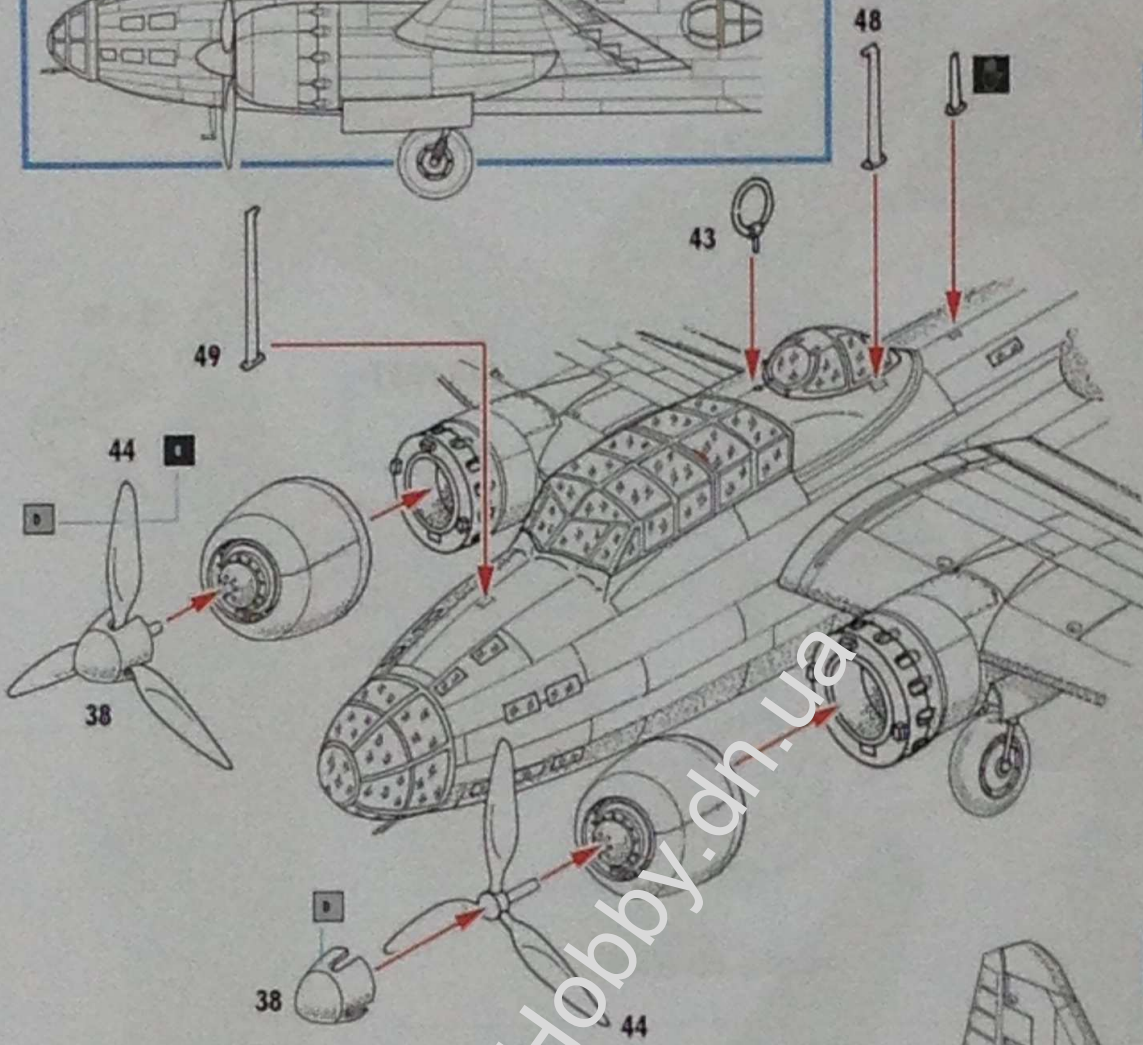

22

21

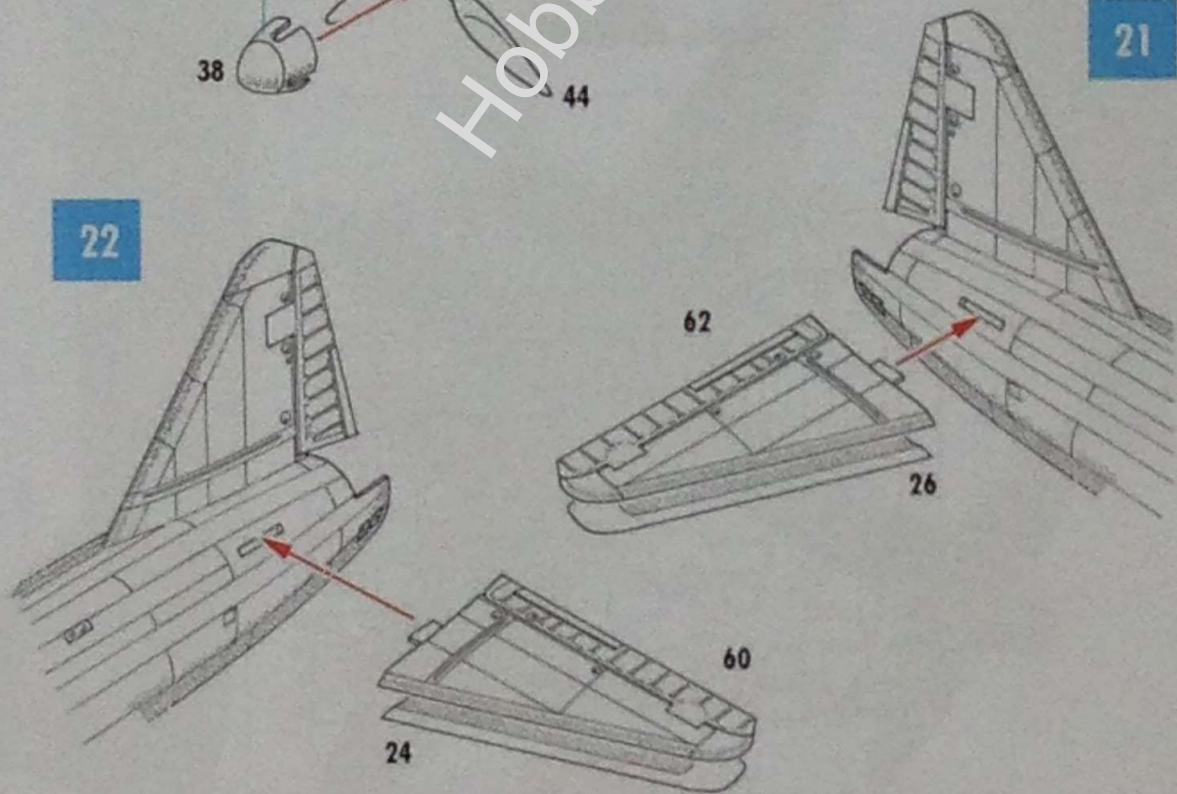

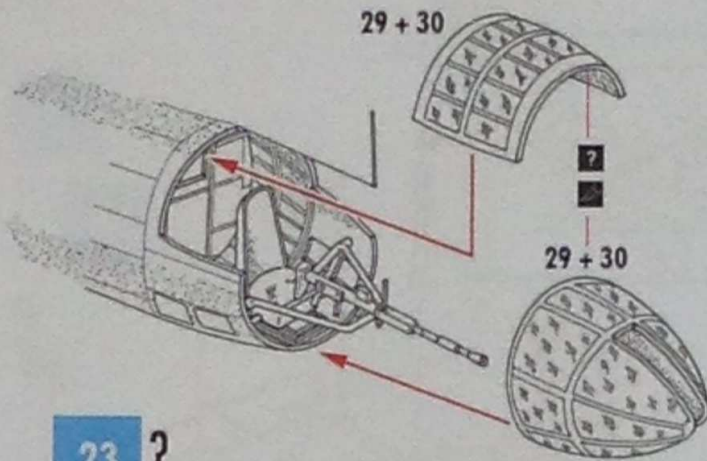

23 ?

24

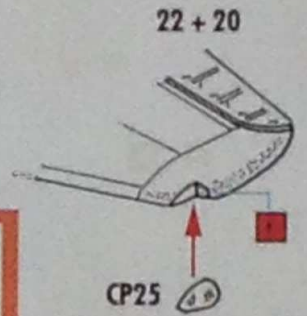
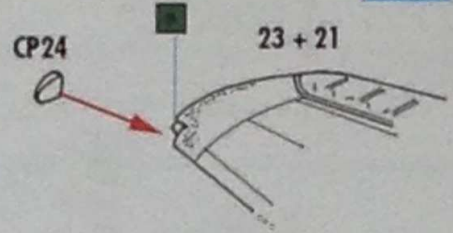

**CLEAR PART
+
MASK**

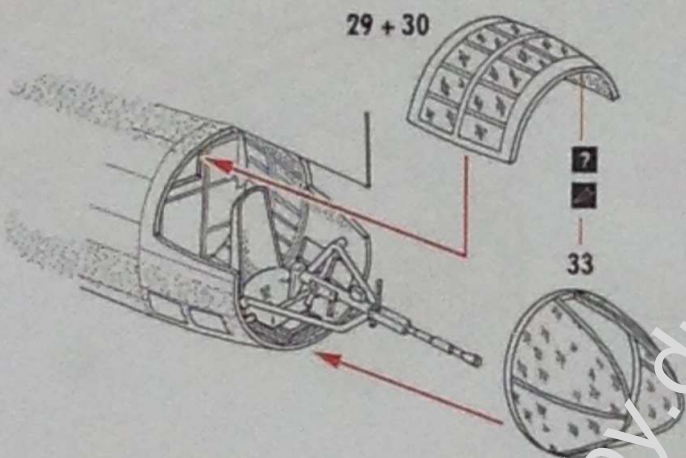
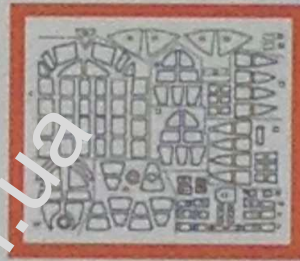

Masks numbers

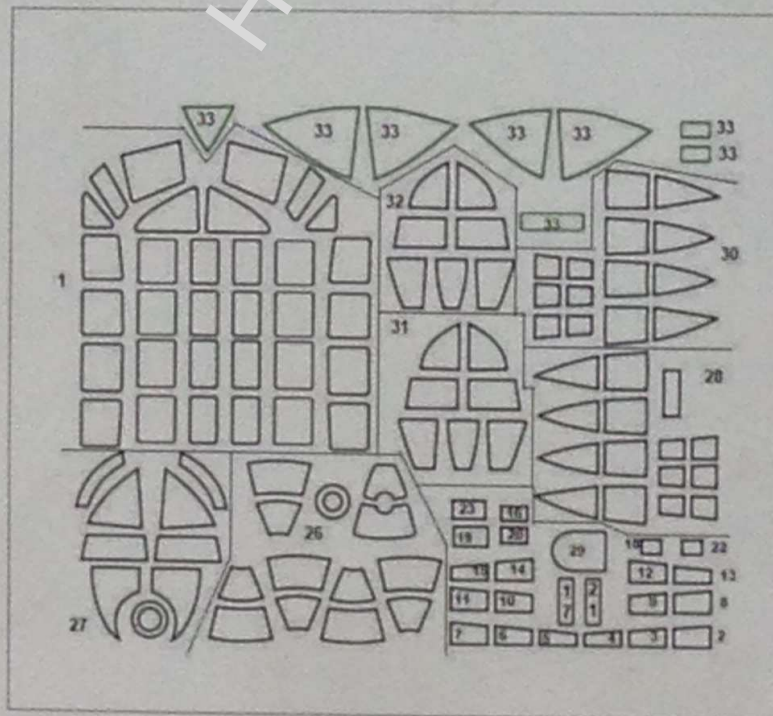

32-203, 732. námořní letecká skupina
32-203, 732nd Naval Air group

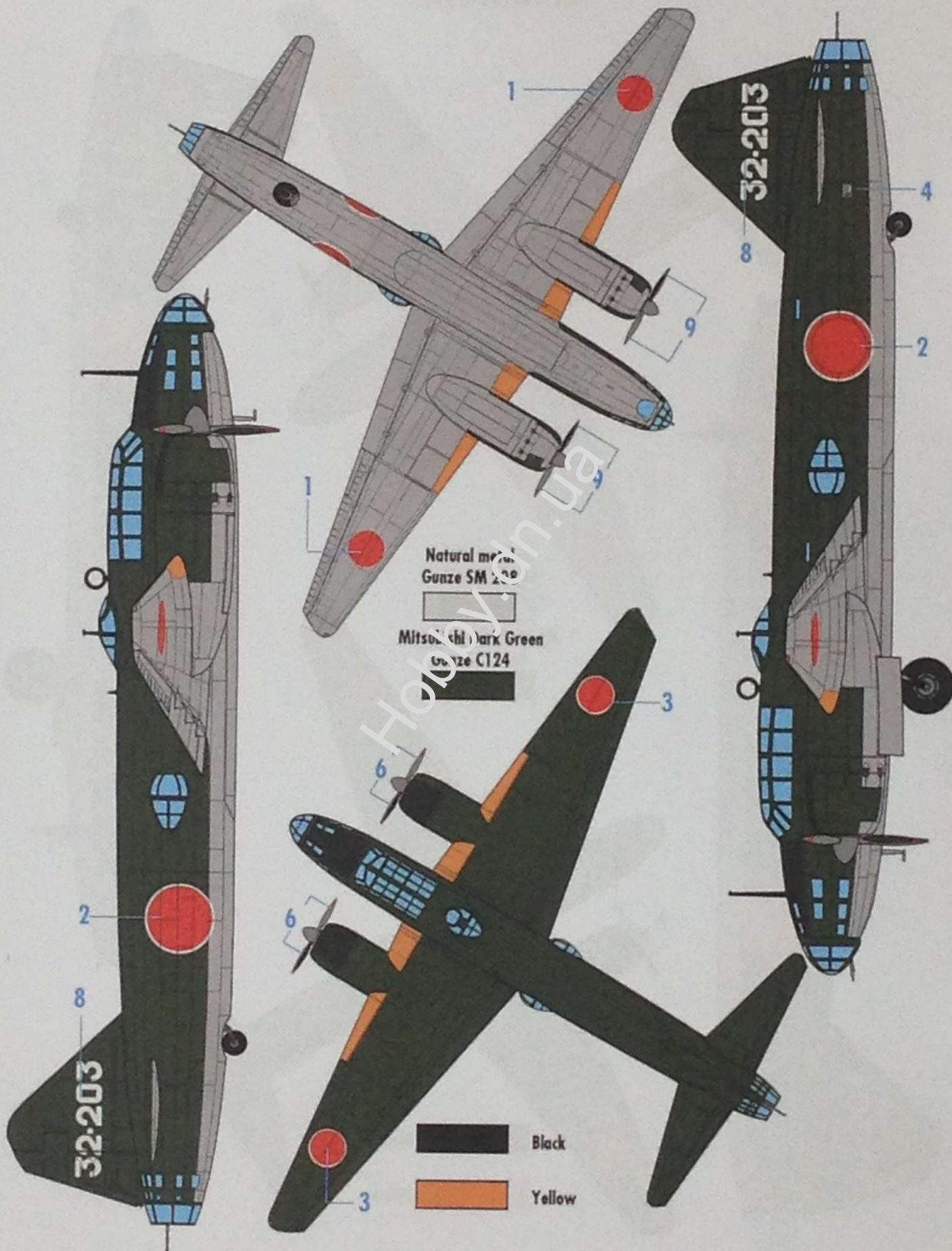

32-304, 732. námořní letecká skupina
32-304, 732nd Naval Air group

