

# Pz.Kpfw.I Ausf.B

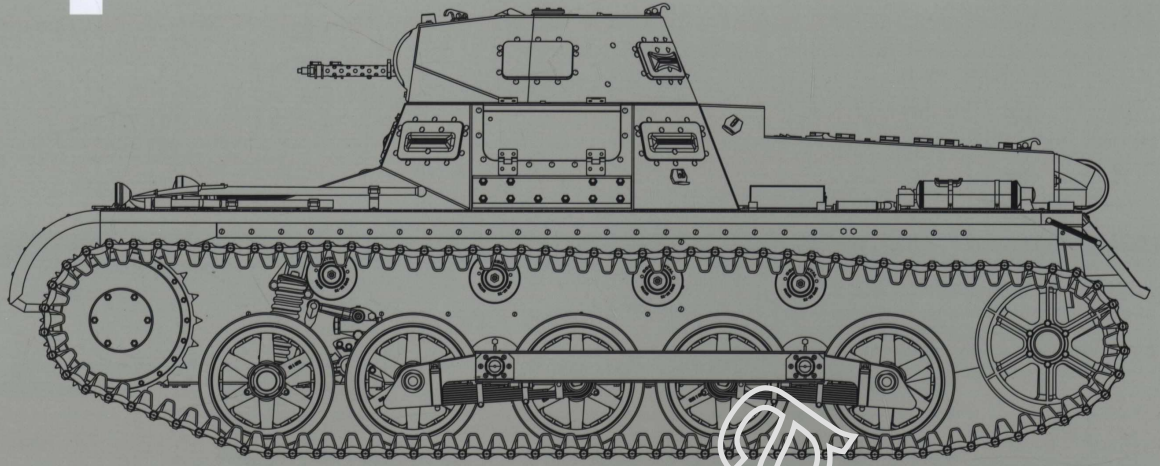

In 1930, Krupp was selected by Waffenprüfwesen 6 (the automotive and tank design office of the German army) to work on the design of a small light tracked tractor named Kleintraktor. It was to be equipped with a 20 mm (0.79 in) auto-cannon, powered by a 60 hp engine and weigh no more than 3000 kg. A year later, in 1931, Krupp sent a description of the Kleintraktor-Fahrgestell (chassis) to Wa.Prw.6. The Krupp Kleintraktor was described as a fast and maneuverable tracked vehicle that weighed about 3.5 tons and could achieve 45 km/h (28 mph). The hull of the tank was made of welded steel plates, it was armed with a 20 mm (0.79 in) auto-cannon and carried 500 rounds.

As development proceeded, several prototypes were made, with some flaws being removed from the tank. The turret was redesigned to fit 2 machine guns and armor protection was increased. In 1933, the Panzer I was considered ready and an order was placed for 150 training tanks, with another 1000 combat-ready tanks being ordered the following year. Neither of these orders were fully delivered.

The Panzerkampfwagen I Ausf.A went into production in late 1934 and continued until early 1936. Around 800 examples were built, having several limitations. The armour was insufficient, being only 13 mm (0.51 in) at its thickest. There were problems with the early suspension, making the tank pitch back at high speeds. There were also concerns about the propulsion, overheating, the commander being both gunner and loader of the two machine guns, and communication going through old fashion vocal tubes. With its two machine guns, light armor and speed, these machines were nothing more than training and scout tanks. Despite this, most of them fought in regular Panzer divisions alongside the improved Ausf.B until late 1941.

Many of the flaws of the Ausf. A were addressed with the introduction of the Ausf. B. This variant first appeared in 1935 and was built until 1938, with around 675 machines produced. The main difference was a longer chassis (by 40 cm), requiring the addition of one more bogie wheel and improved suspension in order to accommodate the much improved water-cooled, six-cylinder Maybach NL 38 TR delivering 90 bhp, along with a new & improved transmission. The weight rose to 5.5 tons, but neither the armament nor armor were modified.

03.02.1010

## PARTS

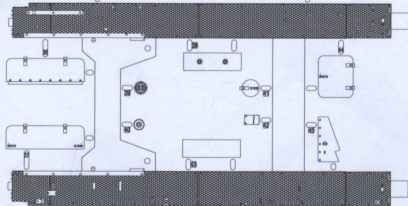
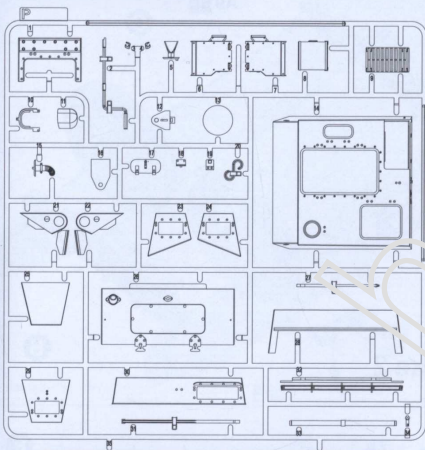

Lower Hull

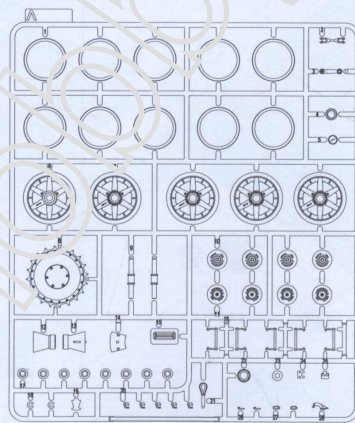

X2

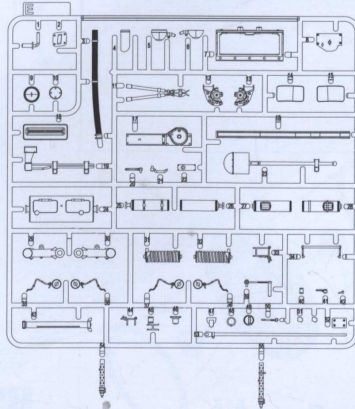

X2

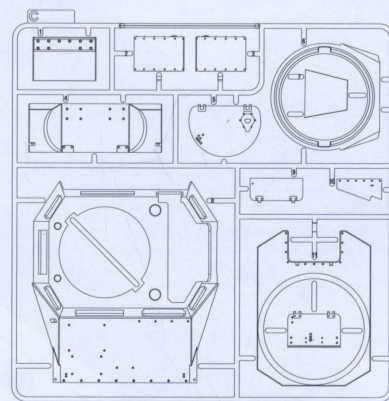

Turret

H X20

Cable

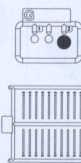

J X10

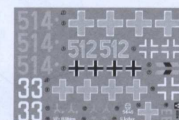

Decal



TP

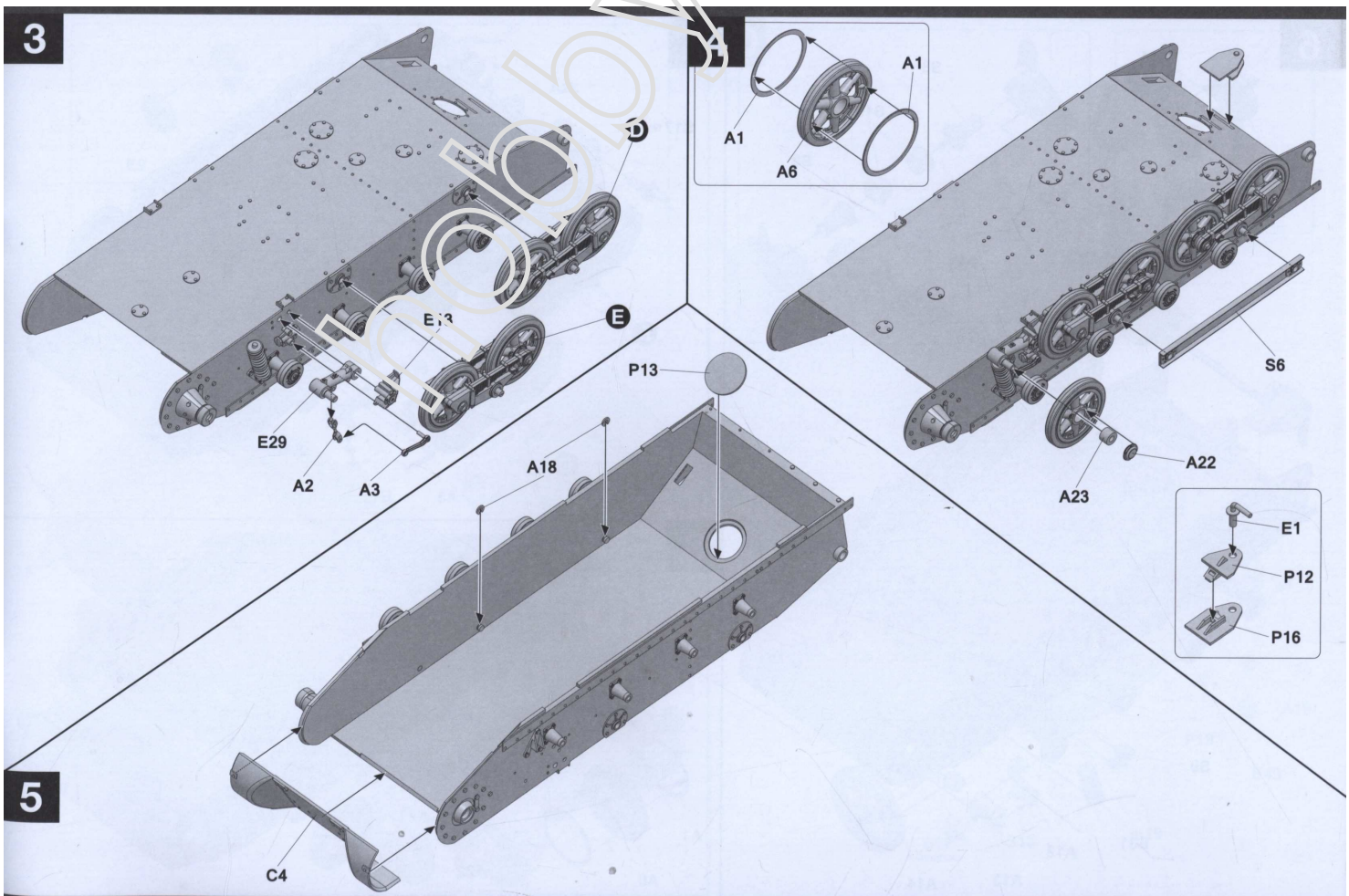
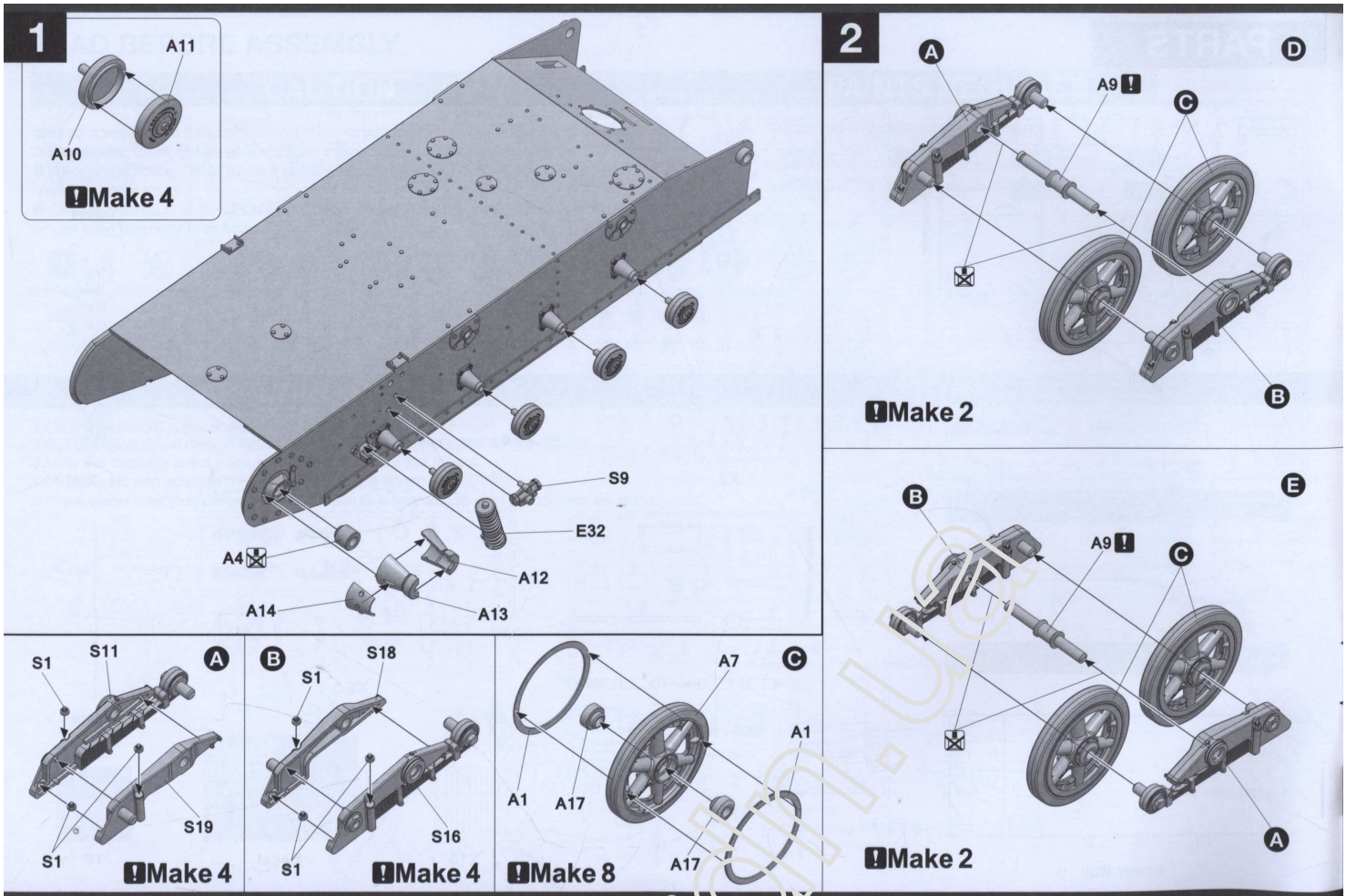

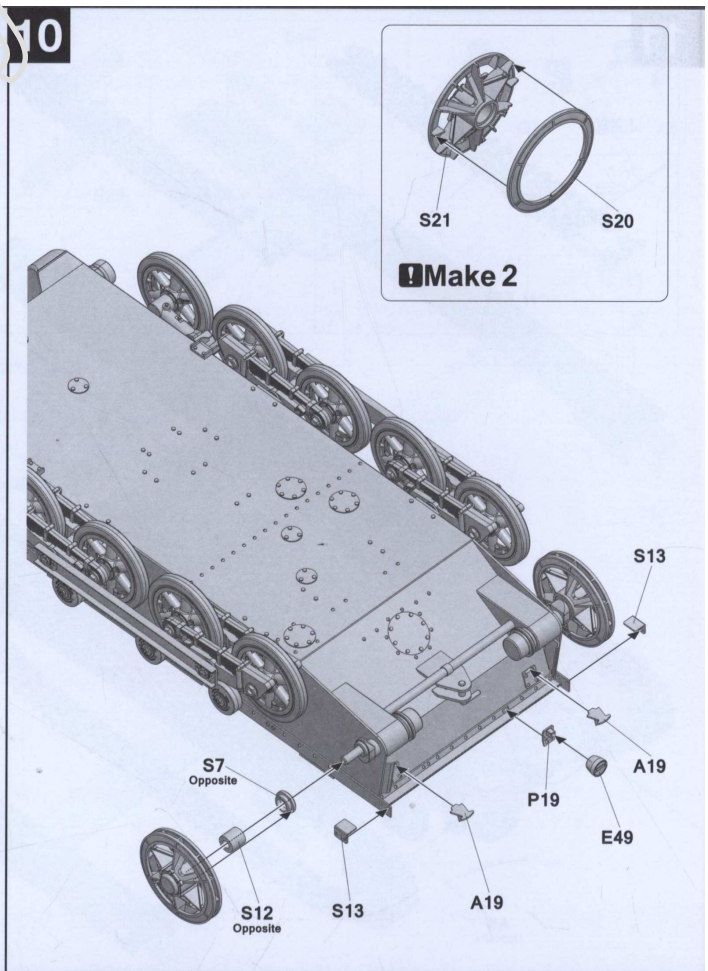
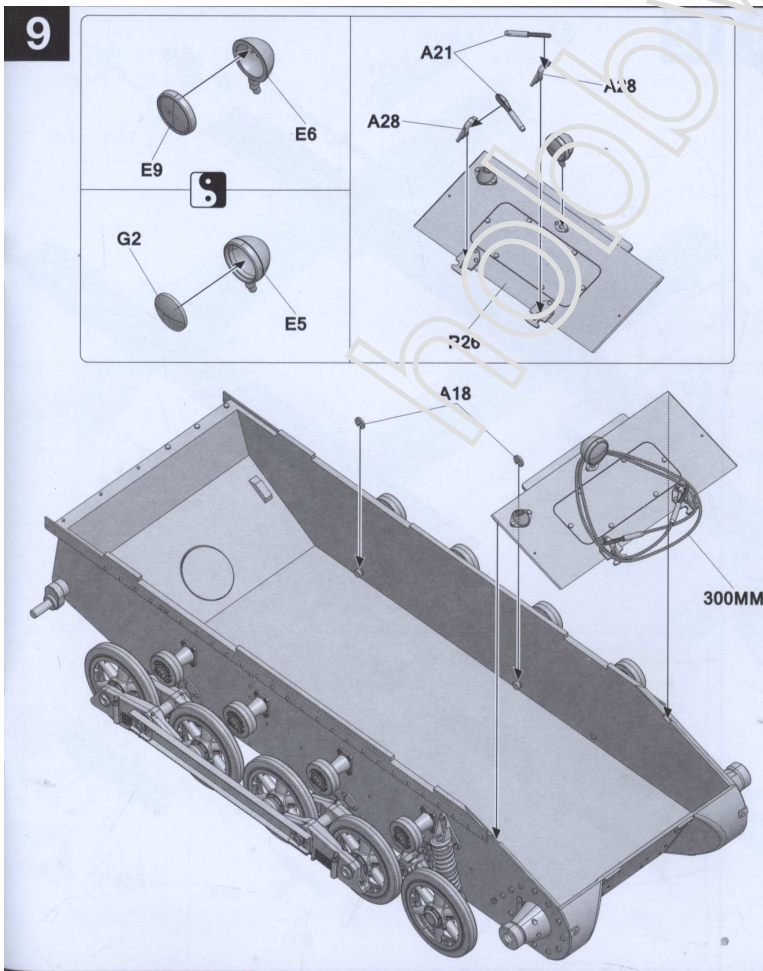
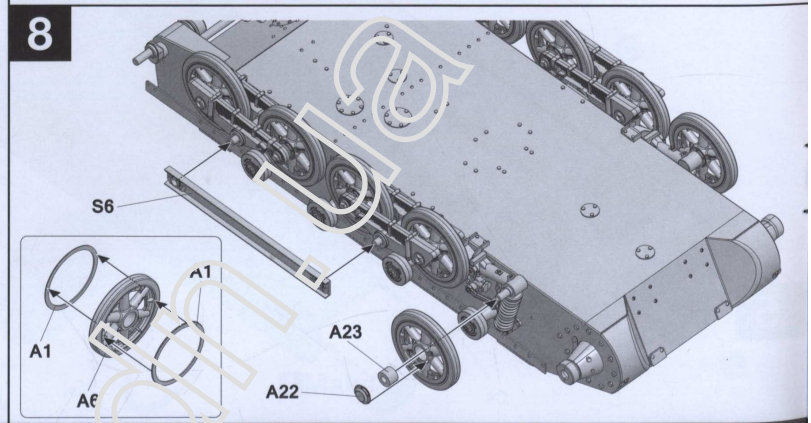
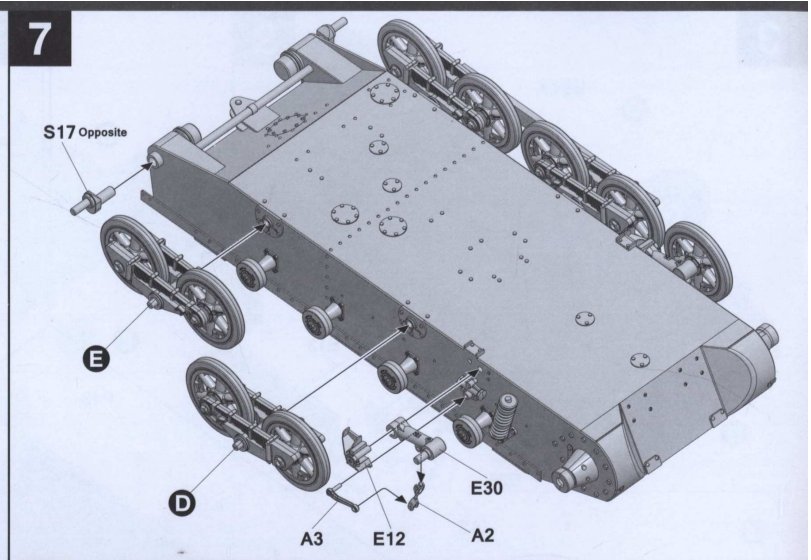
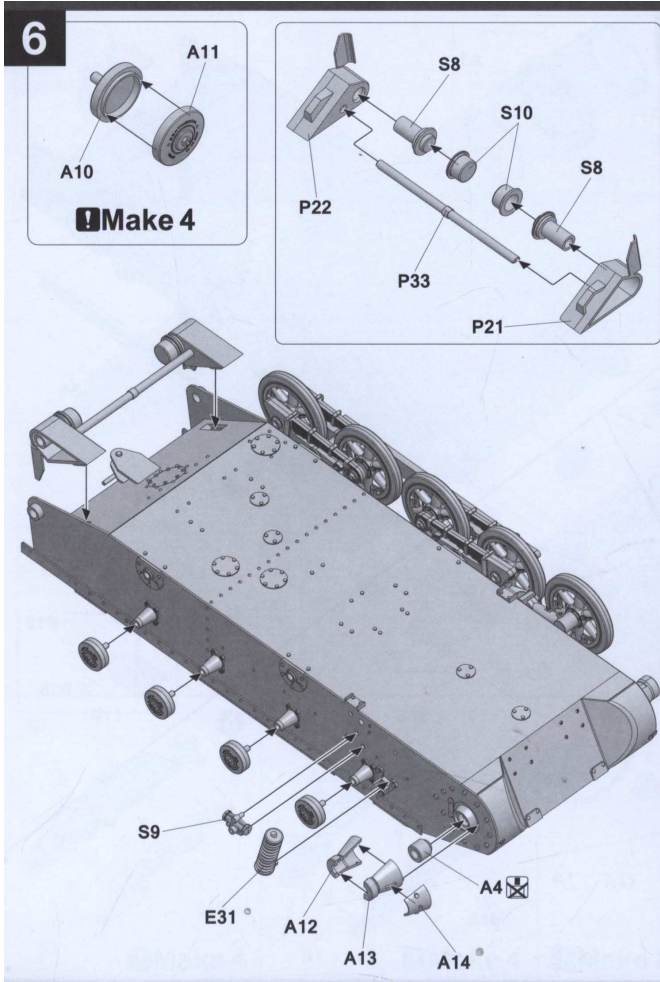

11

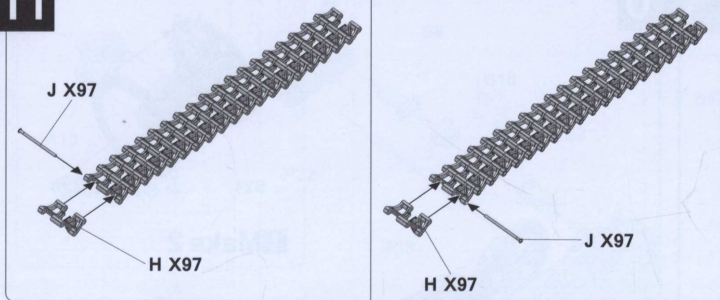

12

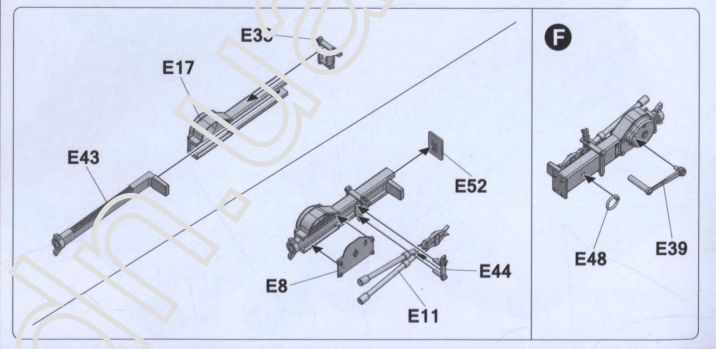
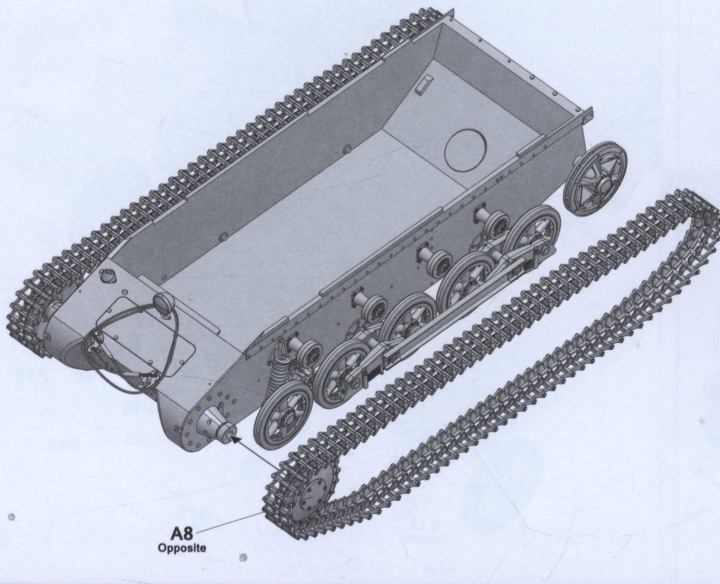
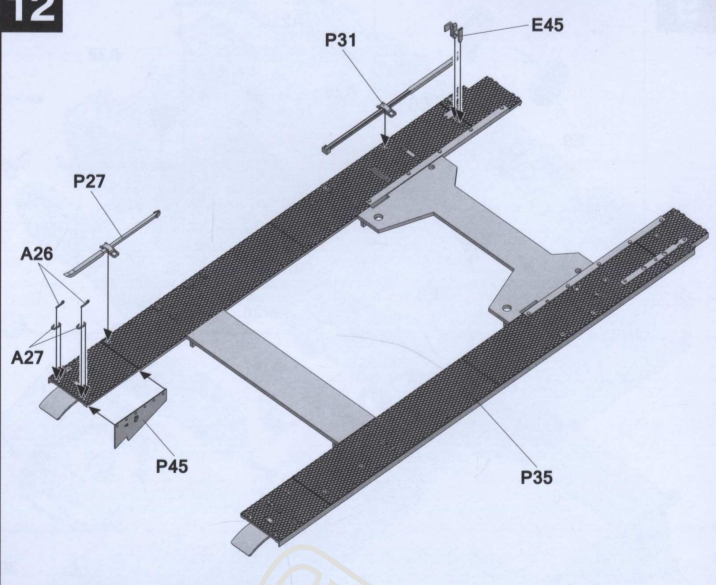

13

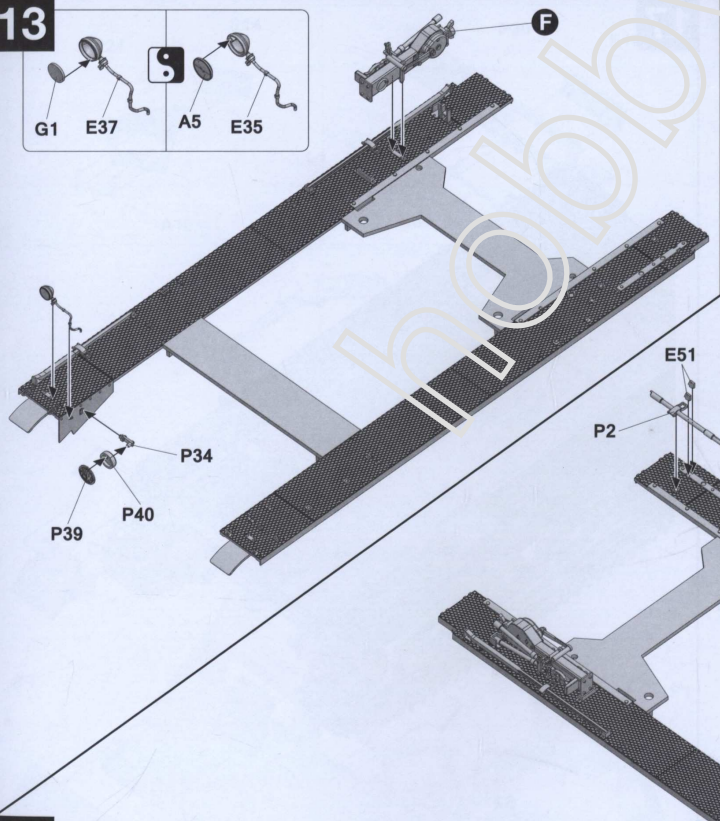

14

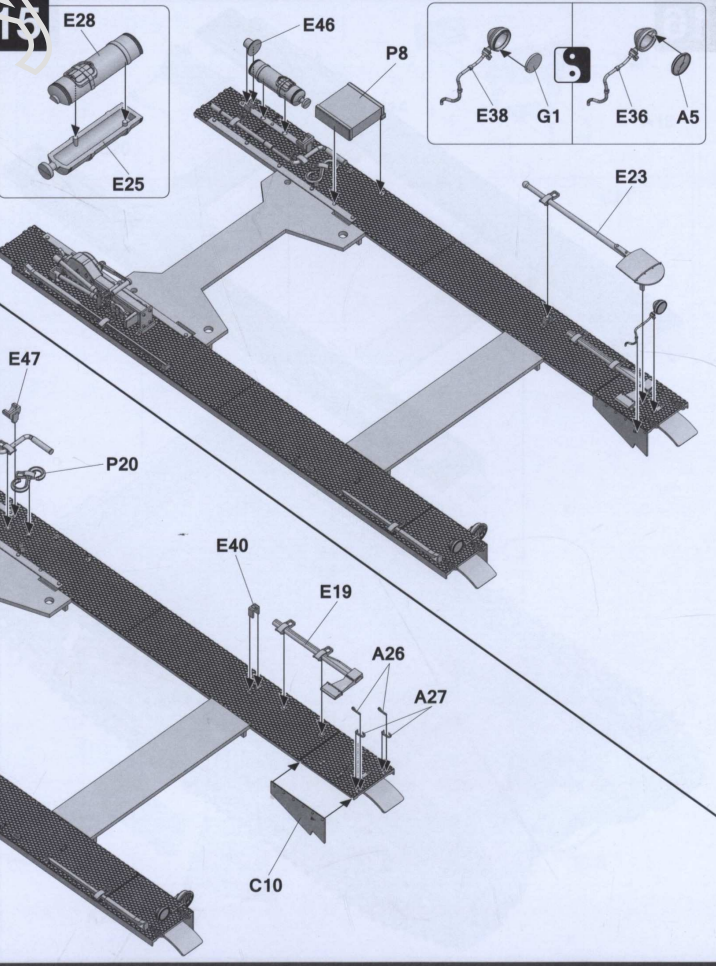

14

16

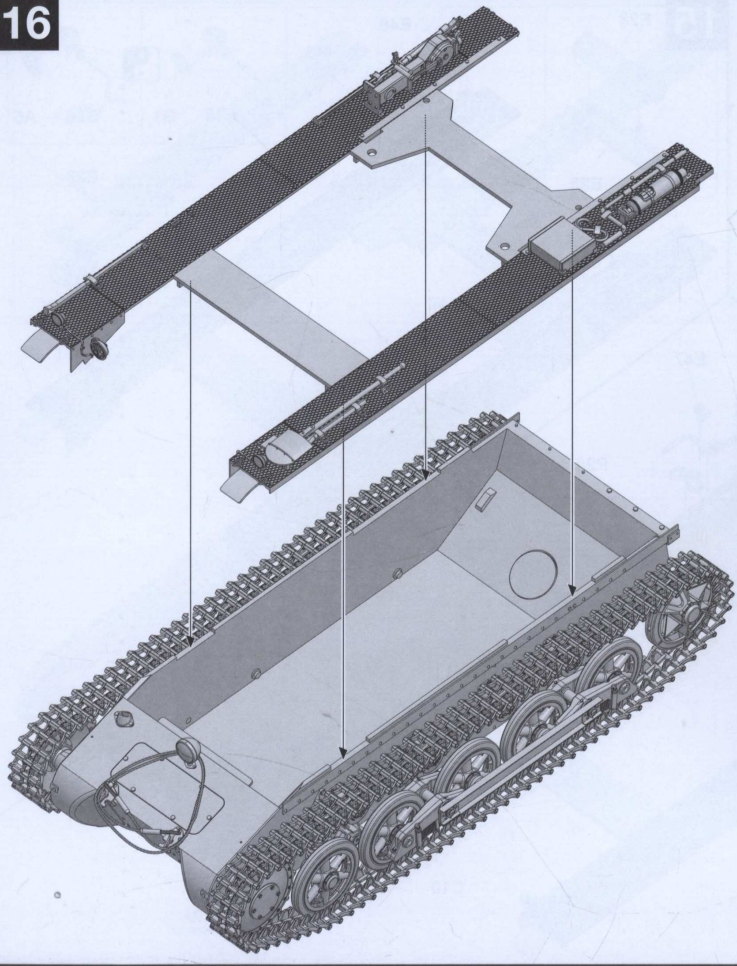

17

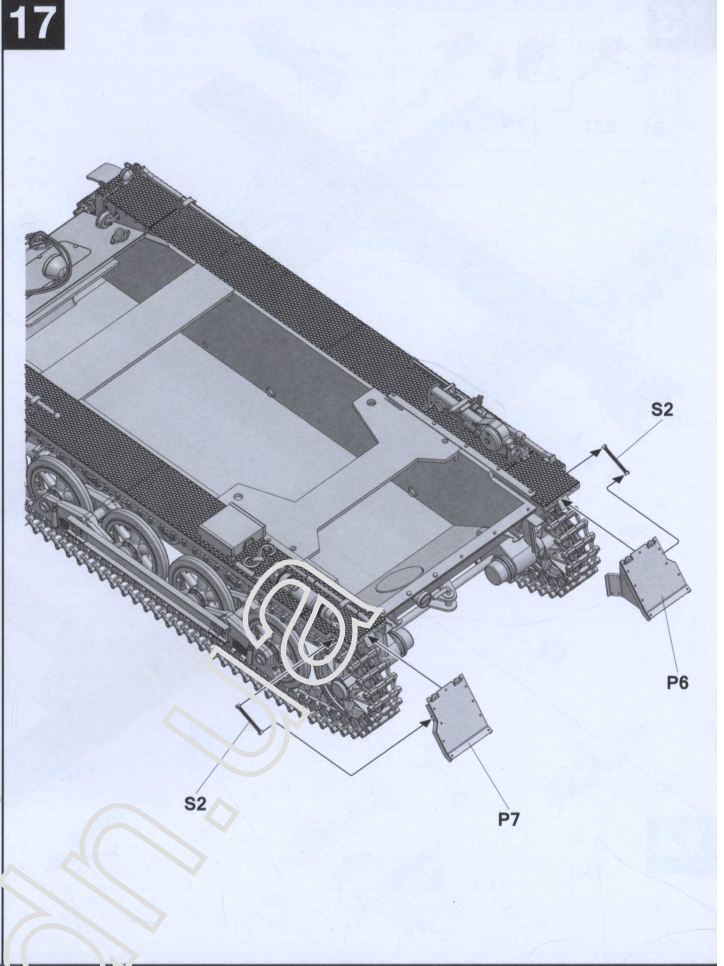

18

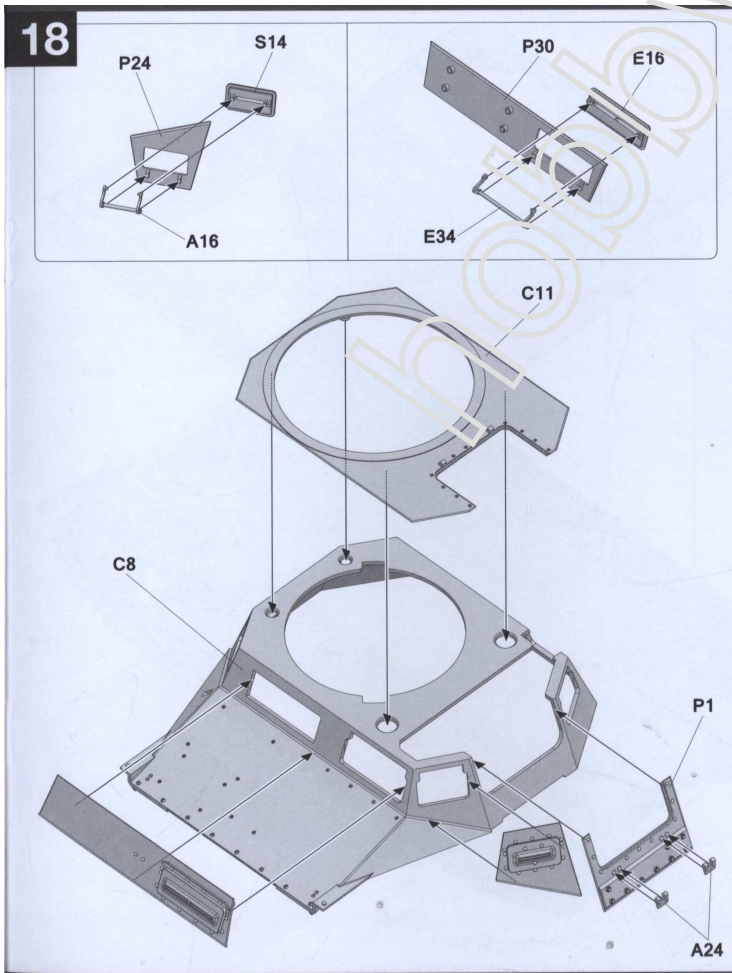

19

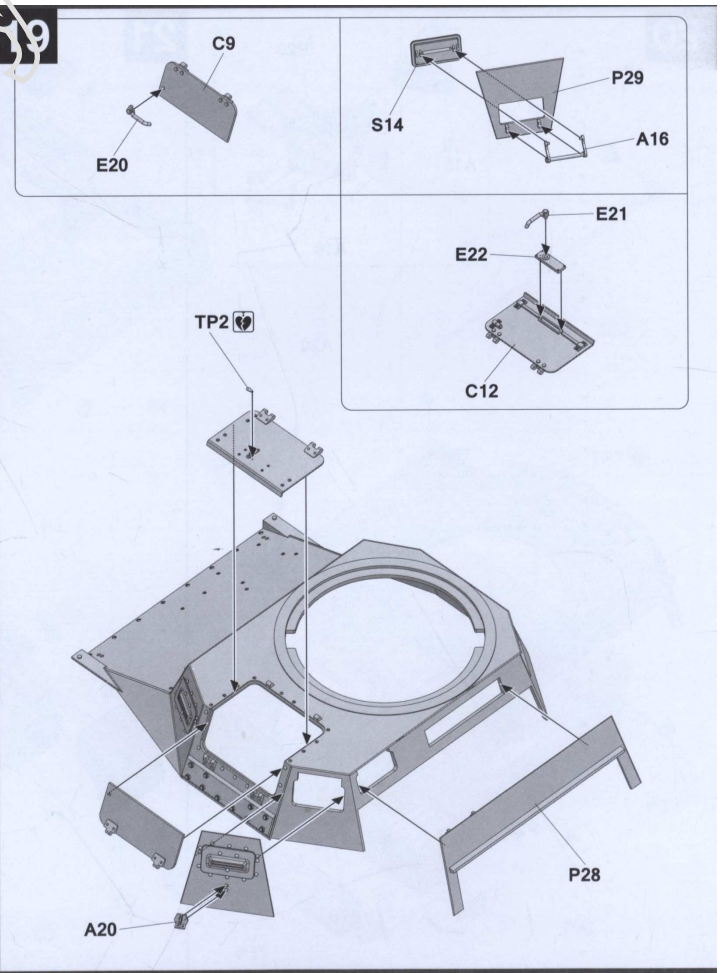

20

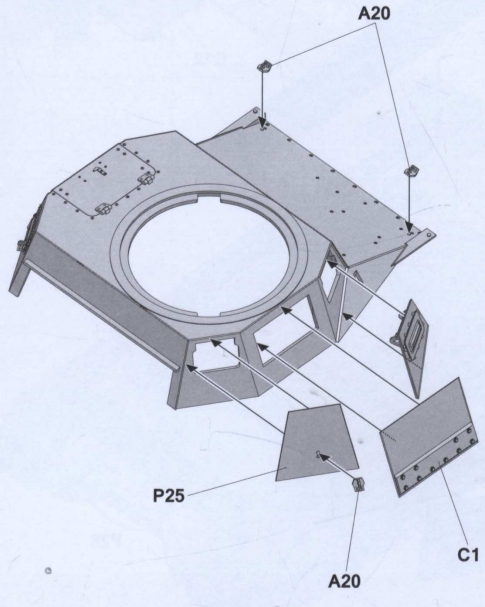
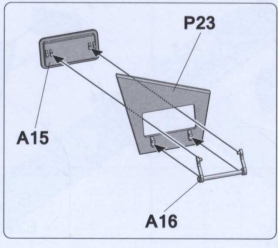

21

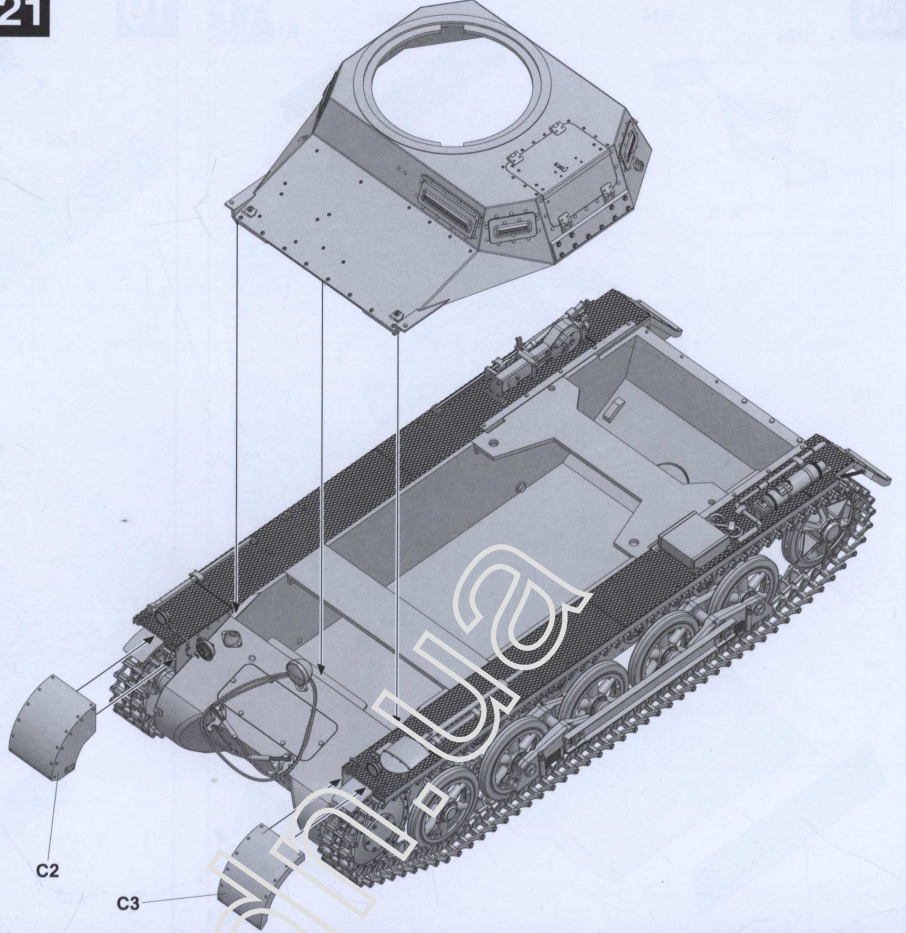

22

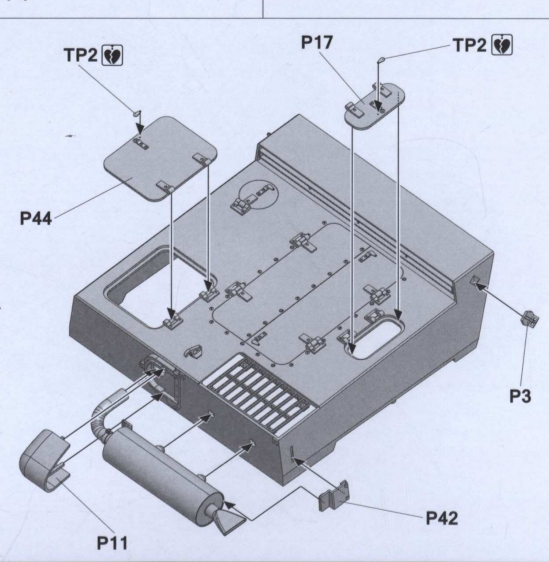
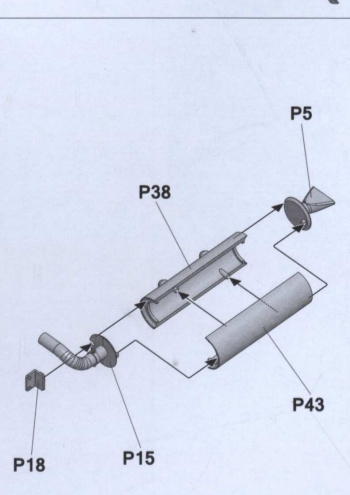
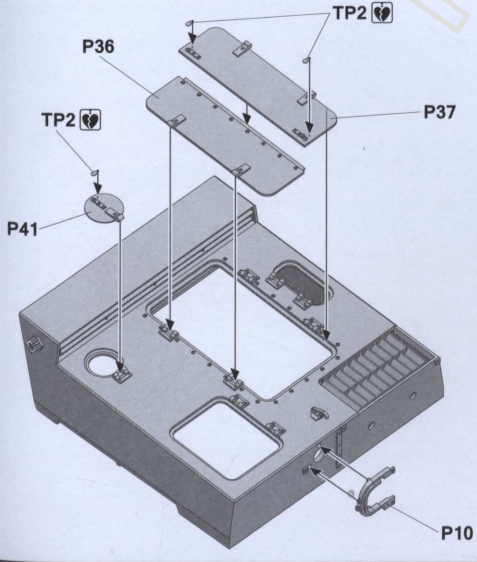
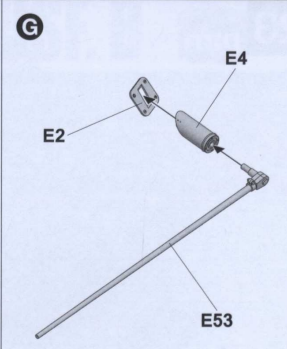
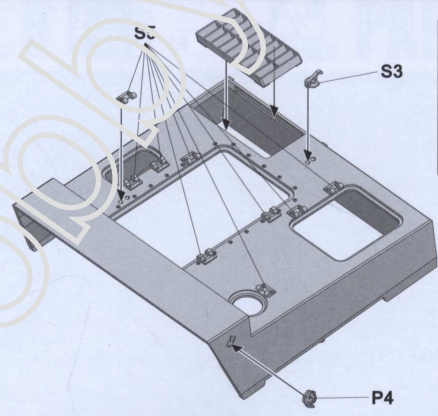
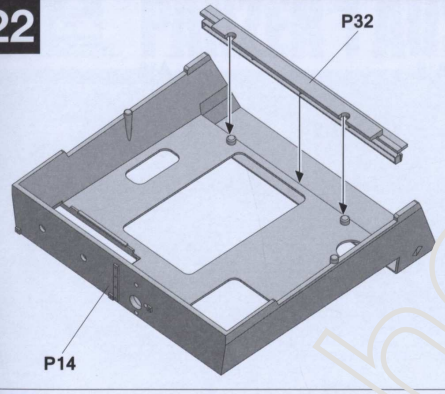

23

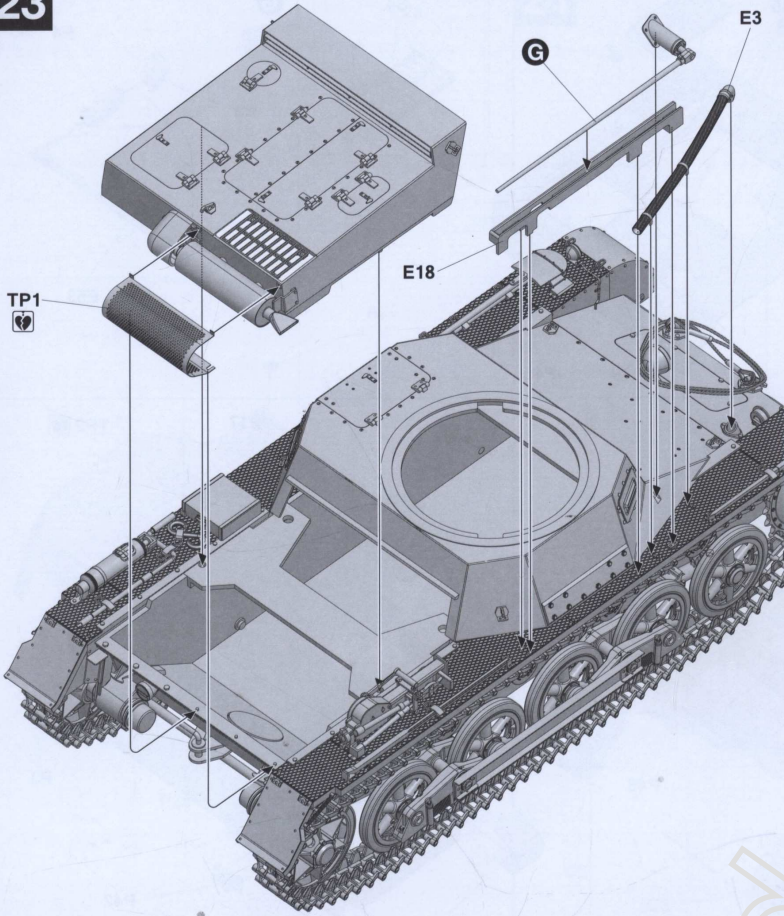

24

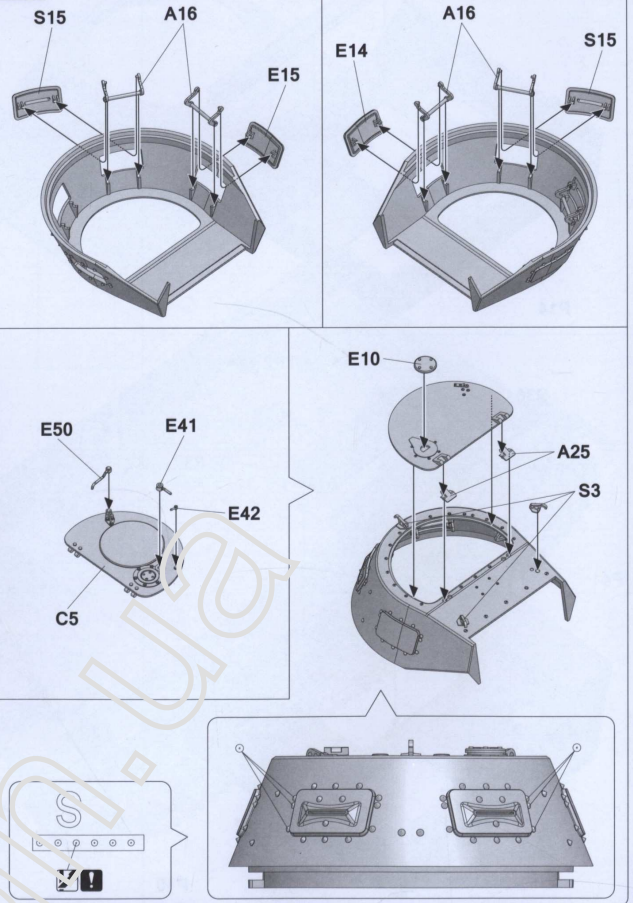

25

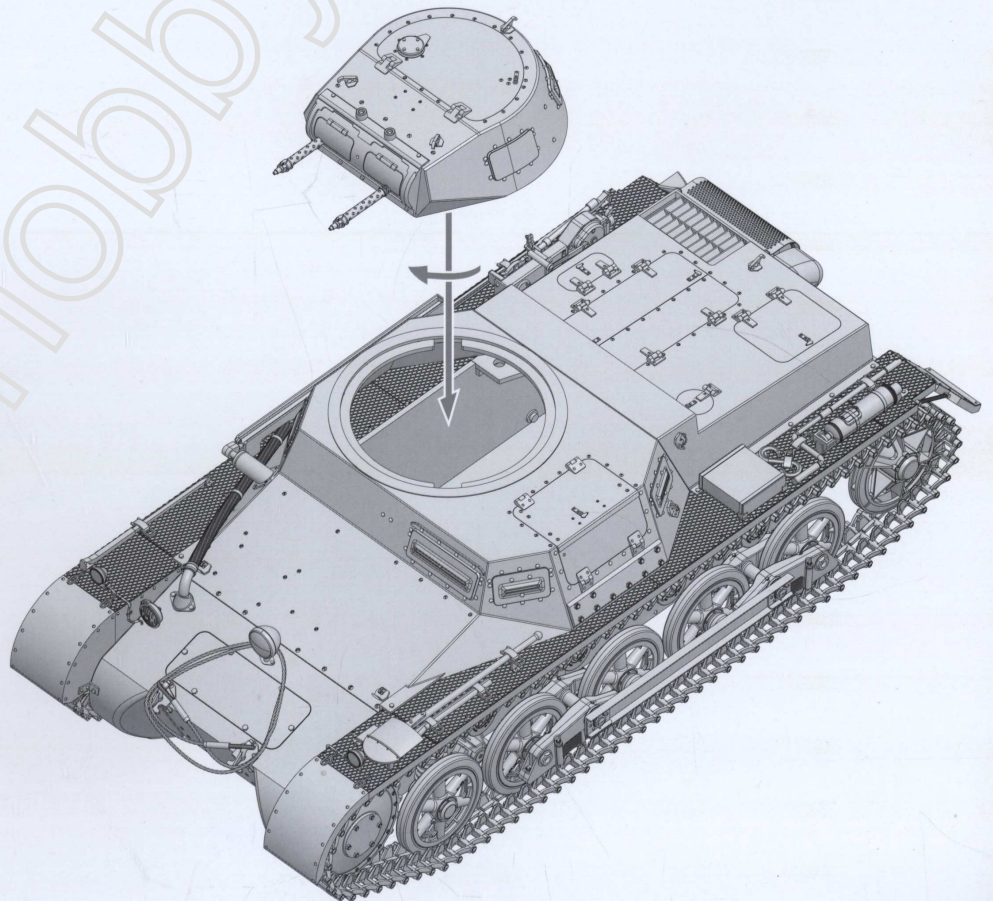
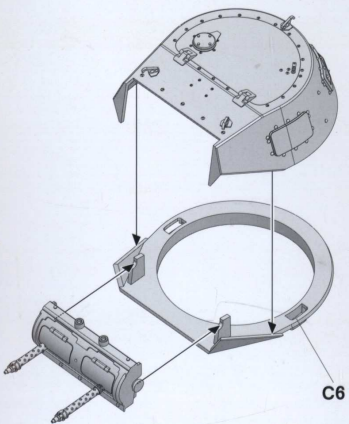
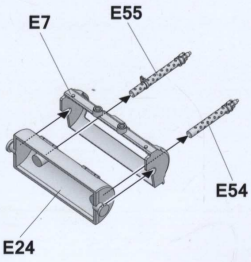

Painting and Marking Guide

TAKOM Ref: 1010

5. Kompanie, Panzer Regiment 35,  
4th Panzer Division, Poland, September 1939

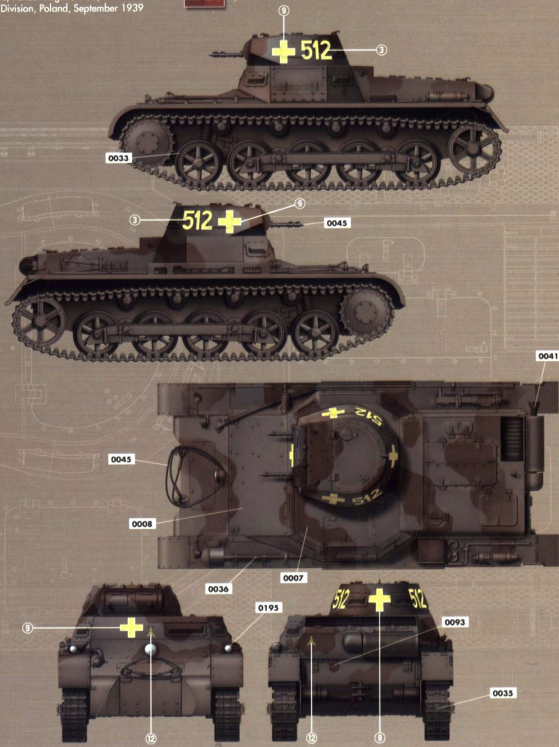
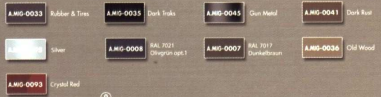

WEATHERING STEPS WITH AMMO PRODUCTS

- |   |   |   |  |
|---|---|---|--|
| <b>1</b> GENERAL WASH<br>A.MIG-1008 Blue Wash for Panzer Grey | <b>3</b> STREAKING<br>A.MIG-1208 Dark Streaking Oxide | <b>5</b> RUST<br>A.MIG-1254 Streakingbrusher Rust | <b>7</b> MUD & SPLASHES<br>A.MIG-1751 Dry Steppe     |
| <b>2</b> FILTER<br>A.MIG-1022 Dark Grey for White             | <b>4</b> TRACKS WASH<br>A.MIG-1022 Tracks Wash        | <b>6</b> DUST<br>A.MIG-3004 Europe Earth          | <b>8</b> GREASE & OIL<br>A.MIG-1408 Fresh Engine Oil |

Painting and Marking Guide

TAKOM Ref: 1010

Panzer Regiment 31, 5th Panzer Division,  
Pszczyna, Poland, September 1939

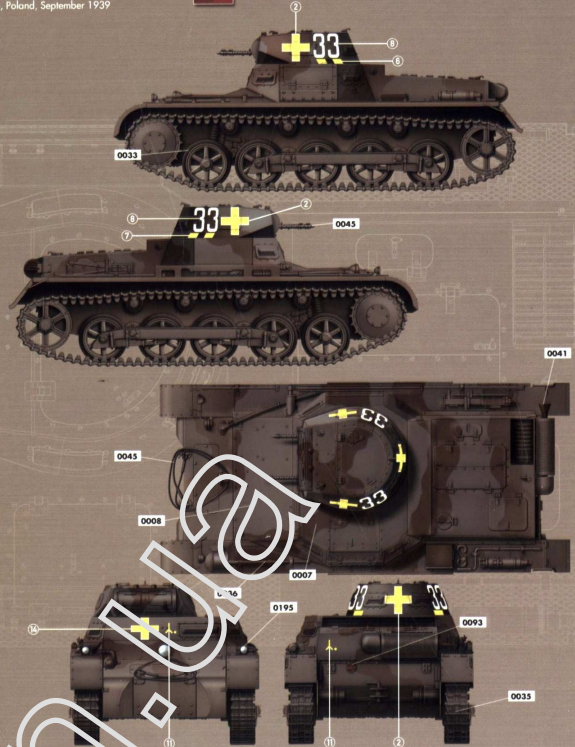

WEATHERING STEPS WITH AMMO PRODUCTS

- |   |   |   |  |
|---|---|---|--|
| <b>1</b> GENERAL WASH<br>A.MIG-1008 Blue Wash for Panzer Grey | <b>3</b> STREAKING<br>A.MIG-1208 Dark Streaking Oxide | <b>5</b> RUST<br>A.MIG-1254 Streakingbrusher Rust | <b>7</b> MUD & SPLASHES<br>A.MIG-1751 Dry Steppe     |
| <b>2</b> FILTER<br>A.MIG-1022 Dark Grey for White             | <b>4</b> TRACKS WASH<br>A.MIG-1022 Tracks Wash        | <b>6</b> DUST<br>A.MIG-3004 Europe Earth          | <b>8</b> GREASE & OIL<br>A.MIG-1408 Fresh Engine Oil |

Painting and Marking Guide

TAKOM Ref: 1010

5. Kompanie, Panzer Regiment 36,  
4th Panzer Division, France, June 1940

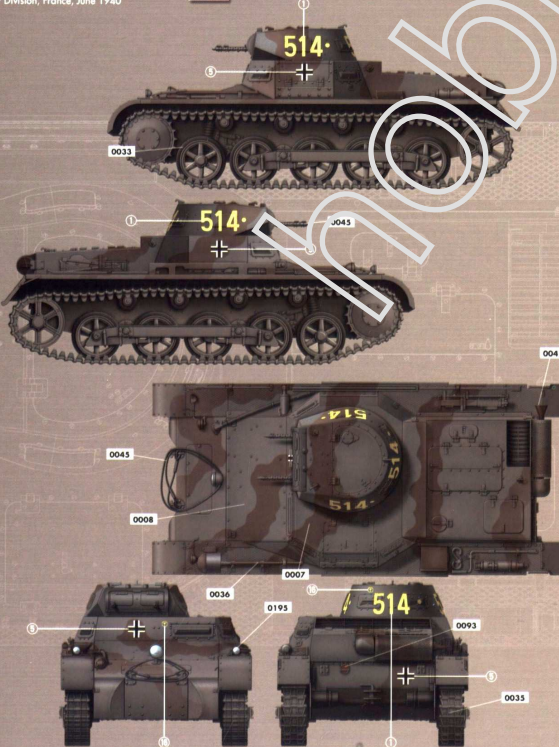
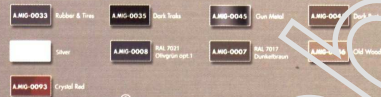

WEATHERING STEPS WITH AMMO PRODUCTS

- |   |   |   |  |
|---|---|---|--|
| <b>1</b> GENERAL WASH<br>A.MIG-1008 Blue Wash for Panzer Grey | <b>3</b> STREAKING<br>A.MIG-1208 Dark Streaking Oxide | <b>5</b> RUST<br>A.MIG-1254 Streakingbrusher Rust | <b>7</b> MUD & SPLASHES<br>A.MIG-1751 Dry Steppe     |
| <b>2</b> FILTER<br>A.MIG-1022 Dark Grey for White             | <b>4</b> TRACKS WASH<br>A.MIG-1022 Tracks Wash        | <b>6</b> DUST<br>A.MIG-3004 Europe Earth          | <b>8</b> GREASE & OIL<br>A.MIG-1408 Fresh Engine Oil |

Painting and Marking Guide

TAKOM Ref: 1010

1. Kompanie, Panzer Regiment 6,  
3rd Panzer Division, France, June 1940

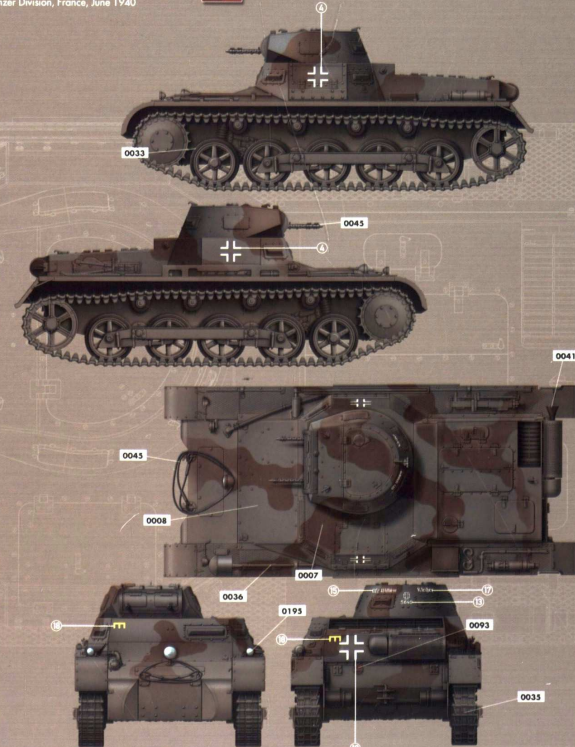

WEATHERING STEPS WITH AMMO PRODUCTS

- |   |   |   |  |
|---|---|---|--|
| <b>1</b> GENERAL WASH<br>A.MIG-1008 Blue Wash for Panzer Grey | <b>3</b> STREAKING<br>A.MIG-1208 Dark Streaking Oxide | <b>5</b> RUST<br>A.MIG-1254 Streakingbrusher Rust | <b>7</b> MUD & SPLASHES<br>A.MIG-1751 Dry Steppe     |
| <b>2</b> FILTER<br>A.MIG-1022 Dark Grey for White             | <b>4</b> TRACKS WASH<br>A.MIG-1022 Tracks Wash        | <b>6</b> DUST<br>A.MIG-3004 Europe Earth          | <b>8</b> GREASE & OIL<br>A.MIG-1408 Fresh Engine Oil |