



TARANGUS



SAAB B17 history

TA-4809

In the early years of the Swedish Air Force, airplanes used were either purchased abroad or license built types. However, with the founding of the Svenska Aeroplans Aktie Bolaget (SAAB) all this would change. The first SAAB designed and built aircraft was initially an ASJA (SAAB's predecessor) project called the L-10, a reconnaissance aircraft. When ASJA was merged with SAAB, the airplane was named SAAB 17. It was now also intended as a dive bomber.

As the European continent was thrown into war, the lack of engines forced three different versions of the SAAB 17 to be developed; the 17A with Pratt & Whitney Twin Wasp, the 17B with Bristol Mercury XXIV and the 17C with Piaggio P. XIbis R.C.40D. The first prototype flew on May 18 1940 and two years later deliveries commenced.

In the Swedish Air Force it served with the following wings; As a bomber with F4 Frösön, F6 Karlsborg, F7 Sätenäs and F12 Kalmar. The reconnaissance version served with F3 Linköping and a special version with floats, called the S 17BS, served with F2 Hägernäs. As the jet age was approaching, the plane was phased out already in 1948. However, it continued to serve as a target tug with several private contractors, among them Svensk Flygtjänst, for another couple of decades.

SAAB 17 was also used by Ethiopia, Finland and Austria. In Ethiopia, it served until 1968. During the last year of world war two, a Danish brigade was trained on the SAAB 17, but when the war ended, these planes were not of interest to Denmark anymore.

Including two prototypes, 325 SAAB B17 aircraft were built.

Today, there is only one flying SAAB 17, operated by the Swedish Air Force historic flight. It was restored to flying condition by former SAAB employees, to celebrate SAAB's 60th birthday in 1997.

SAAB B17A

1/48
scale

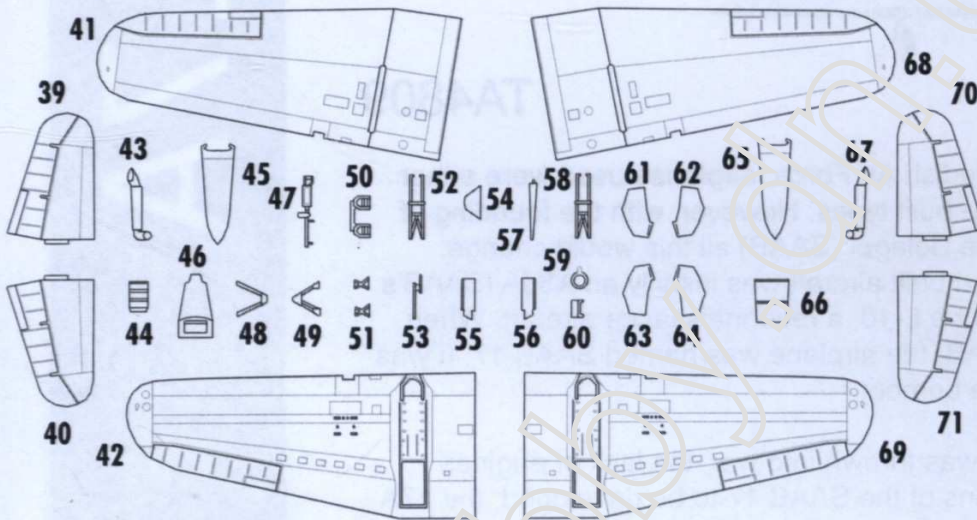
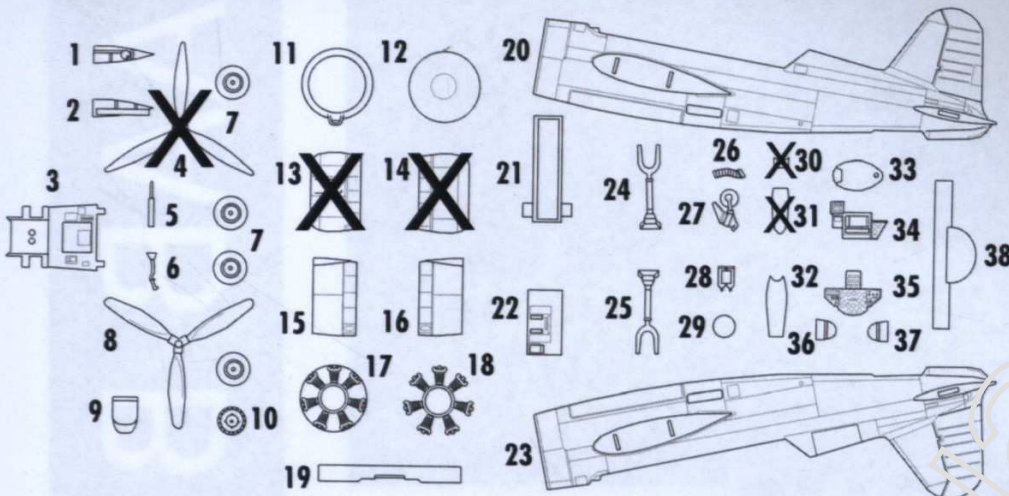

BEND



OPEN HOLE



COLOR



SECOND GLUE



OPTION



SYMETRICAL ASSEMBLY



SCRATCH BUILD



REMOVE

- Black
- Interior Aluminium
- Aluminium
- Dark Green
- Silver
- Brown
- Tyres Black
- Burn Iron
- Chrome
- Natural Metal
- Light Grey
- Gun metal

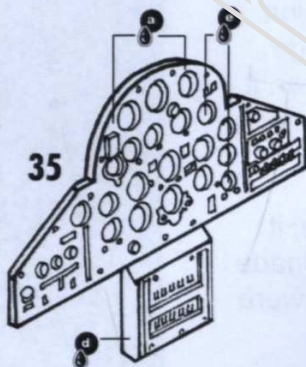

FRONT INSTRUMENT PANEL

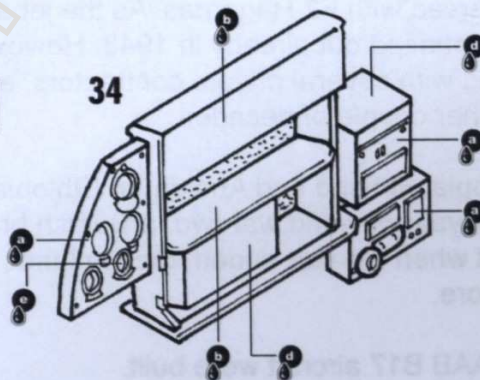

REAR INSTRUMENT PANEL

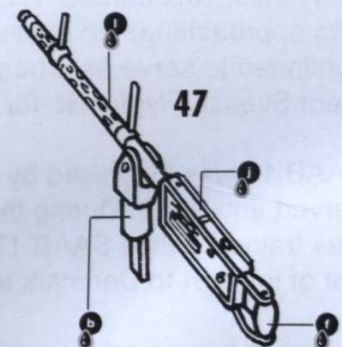

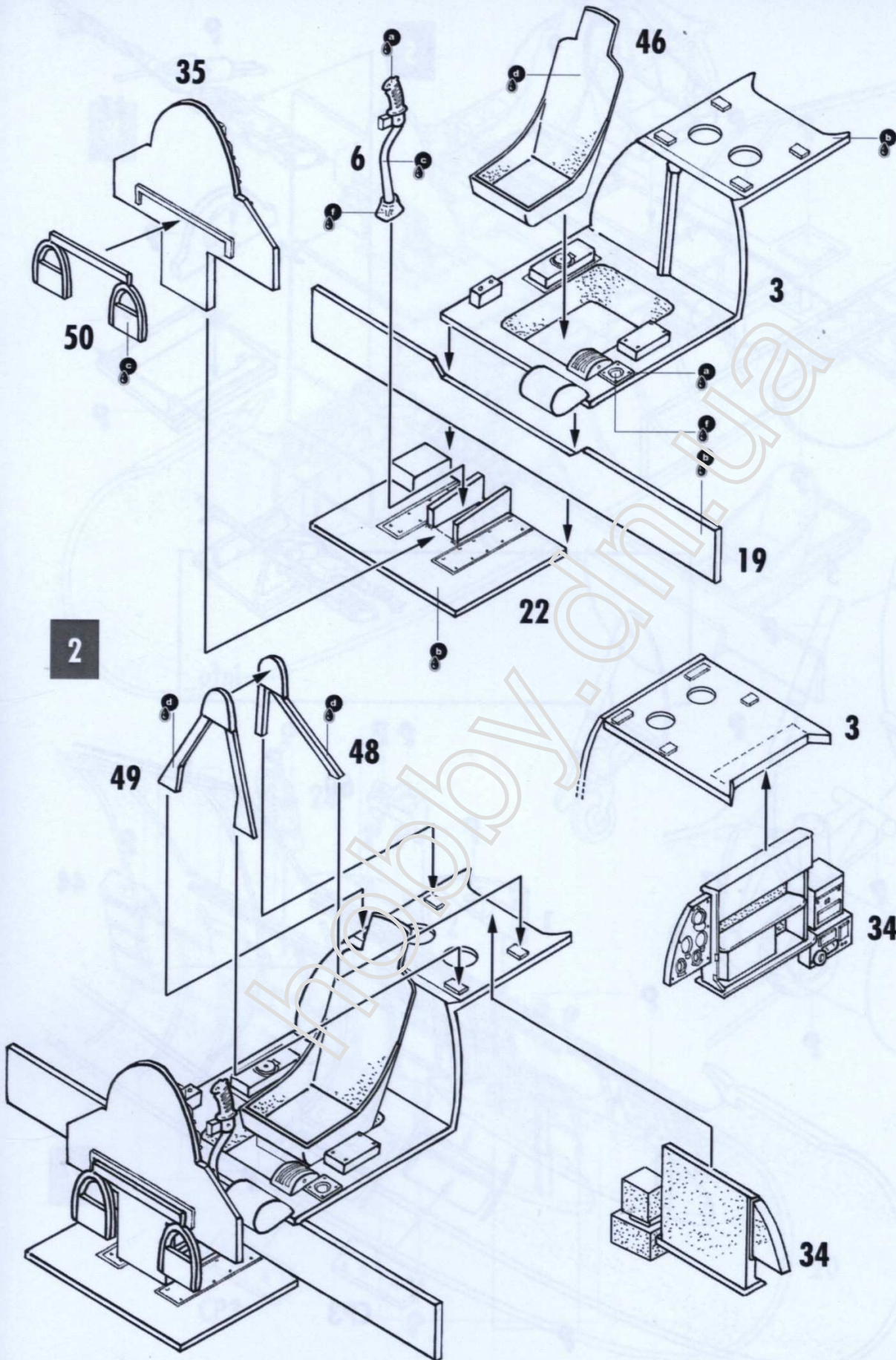

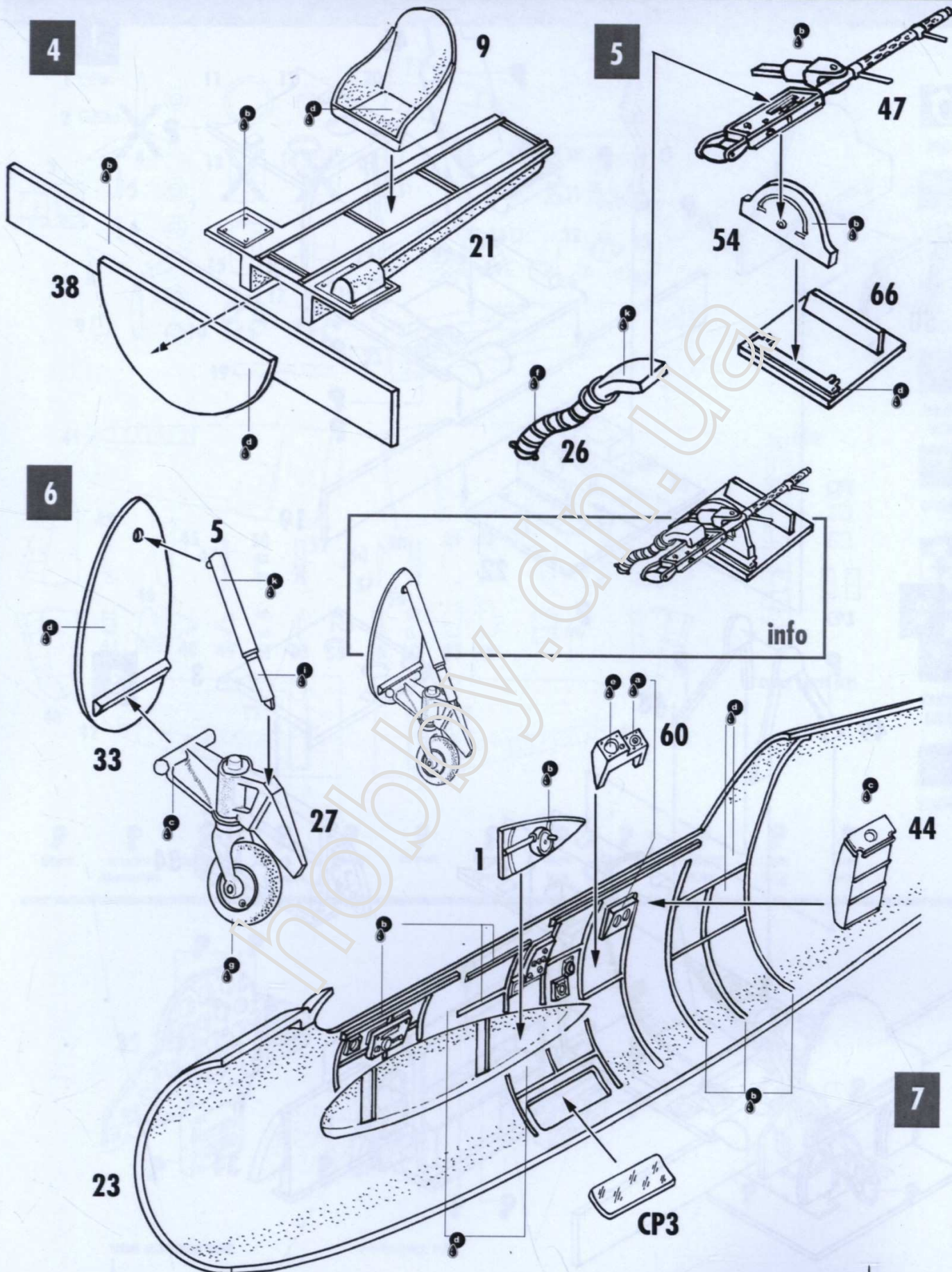

8

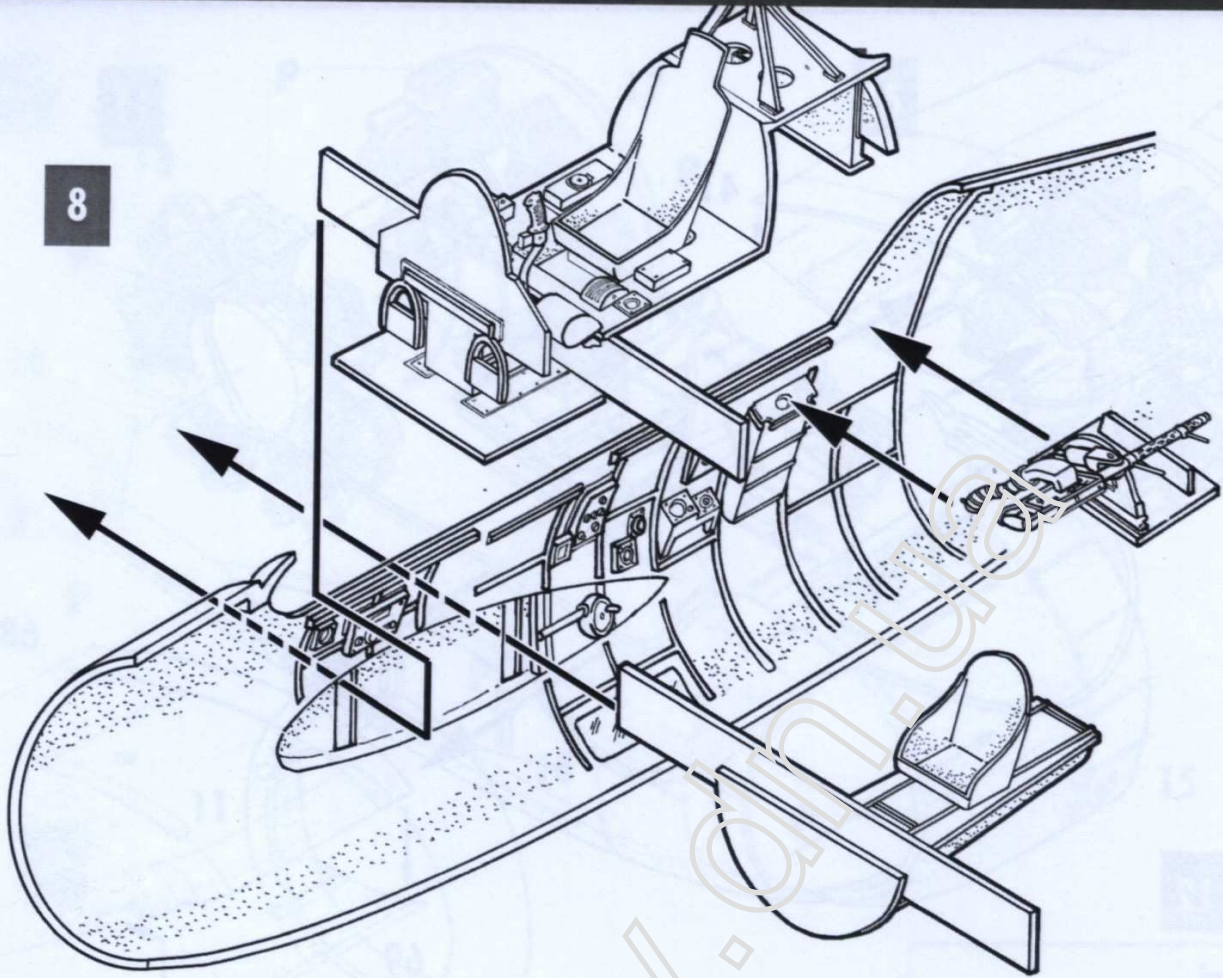

9

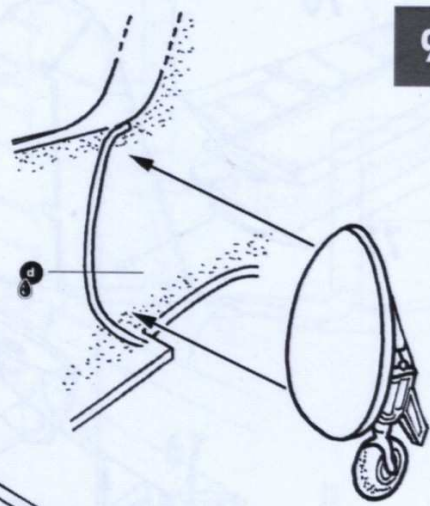

10

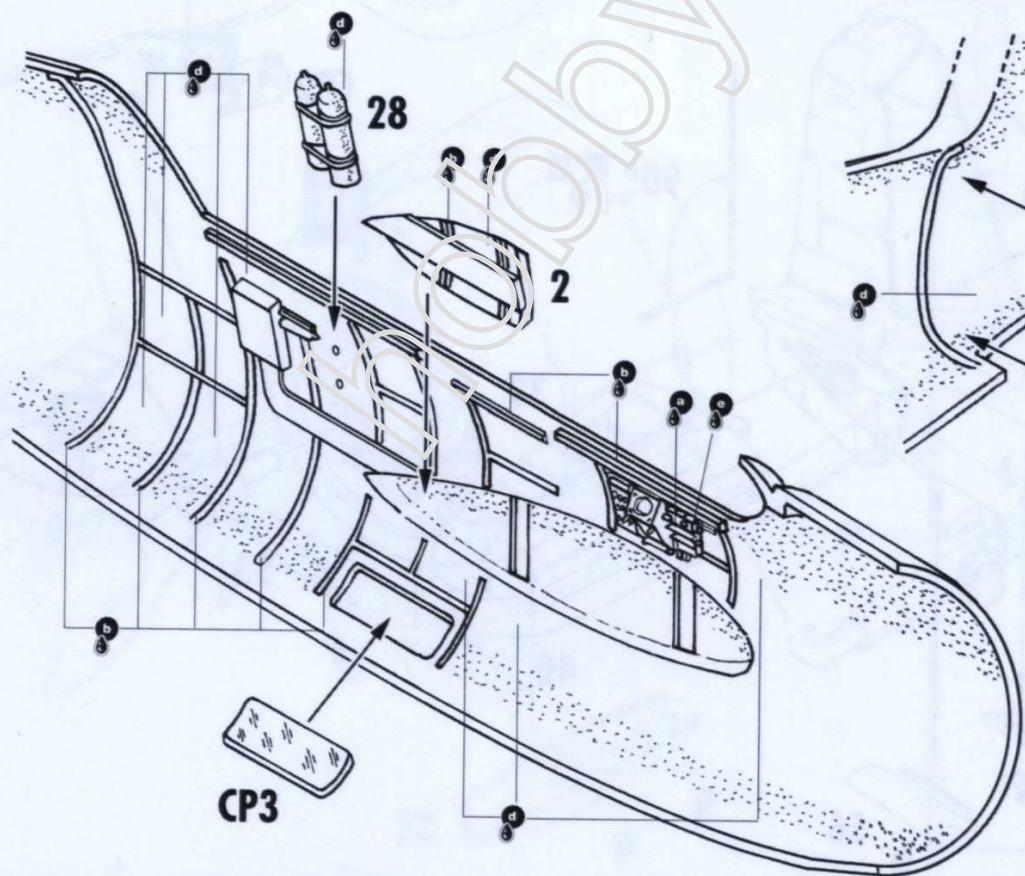

20

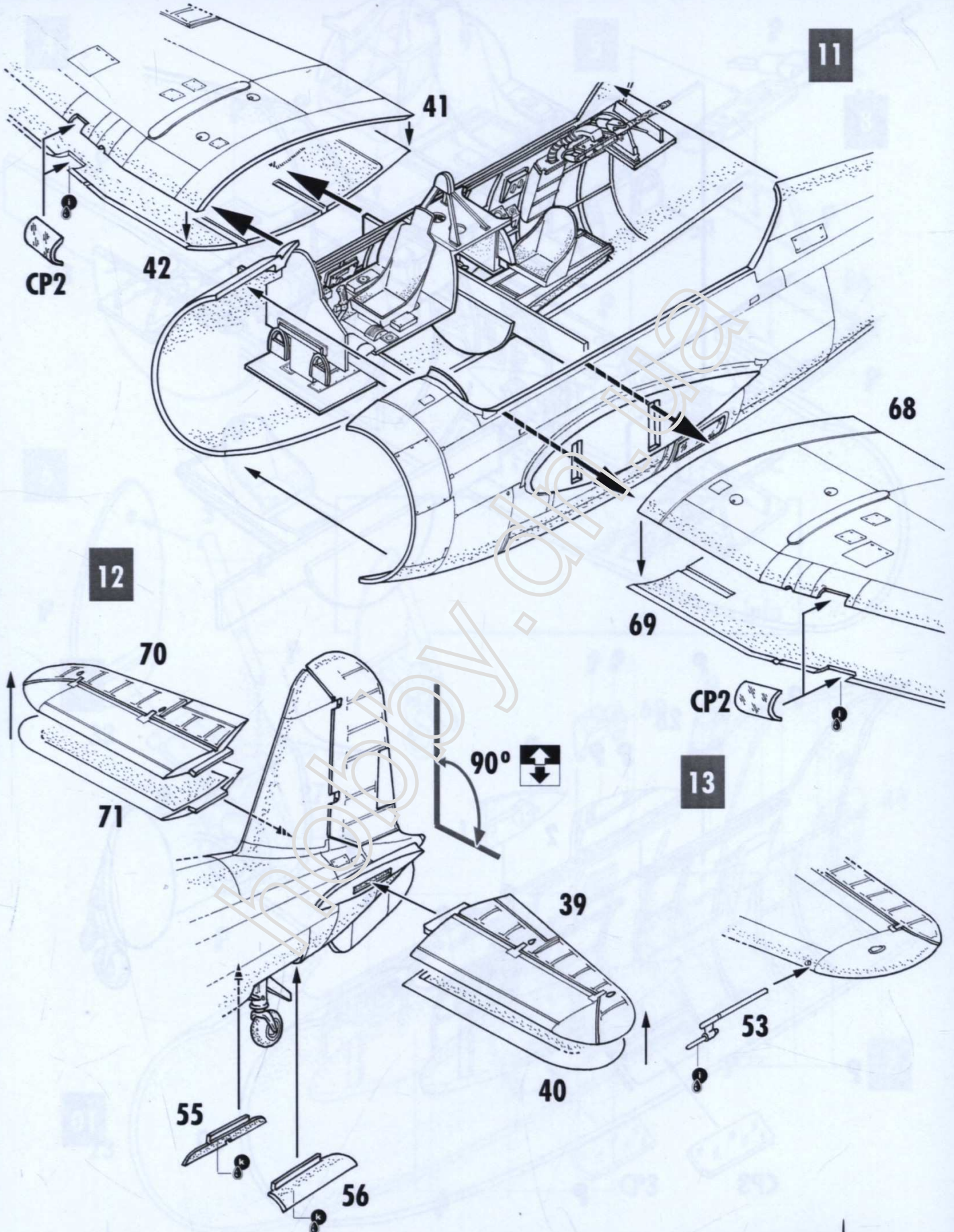

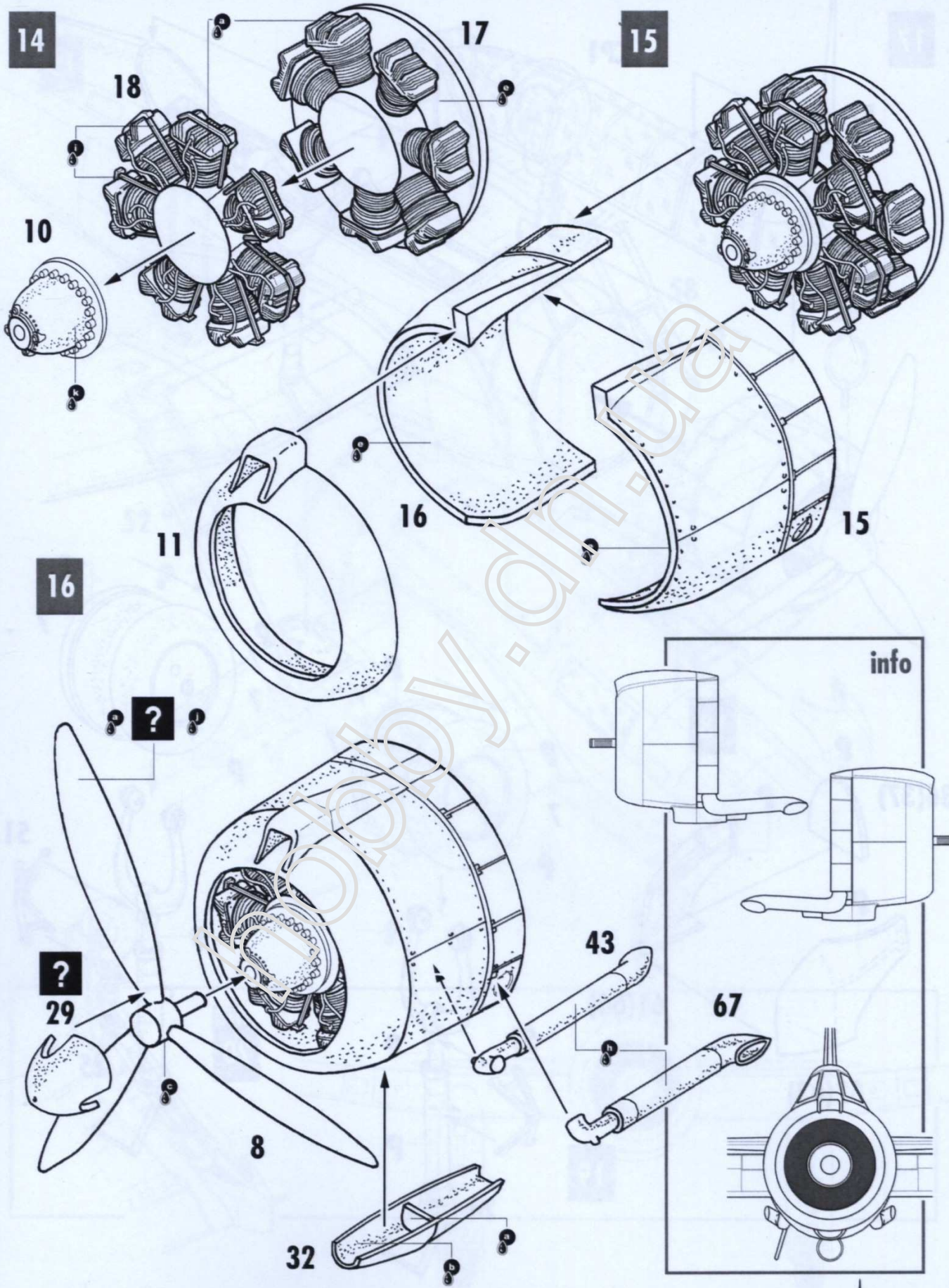

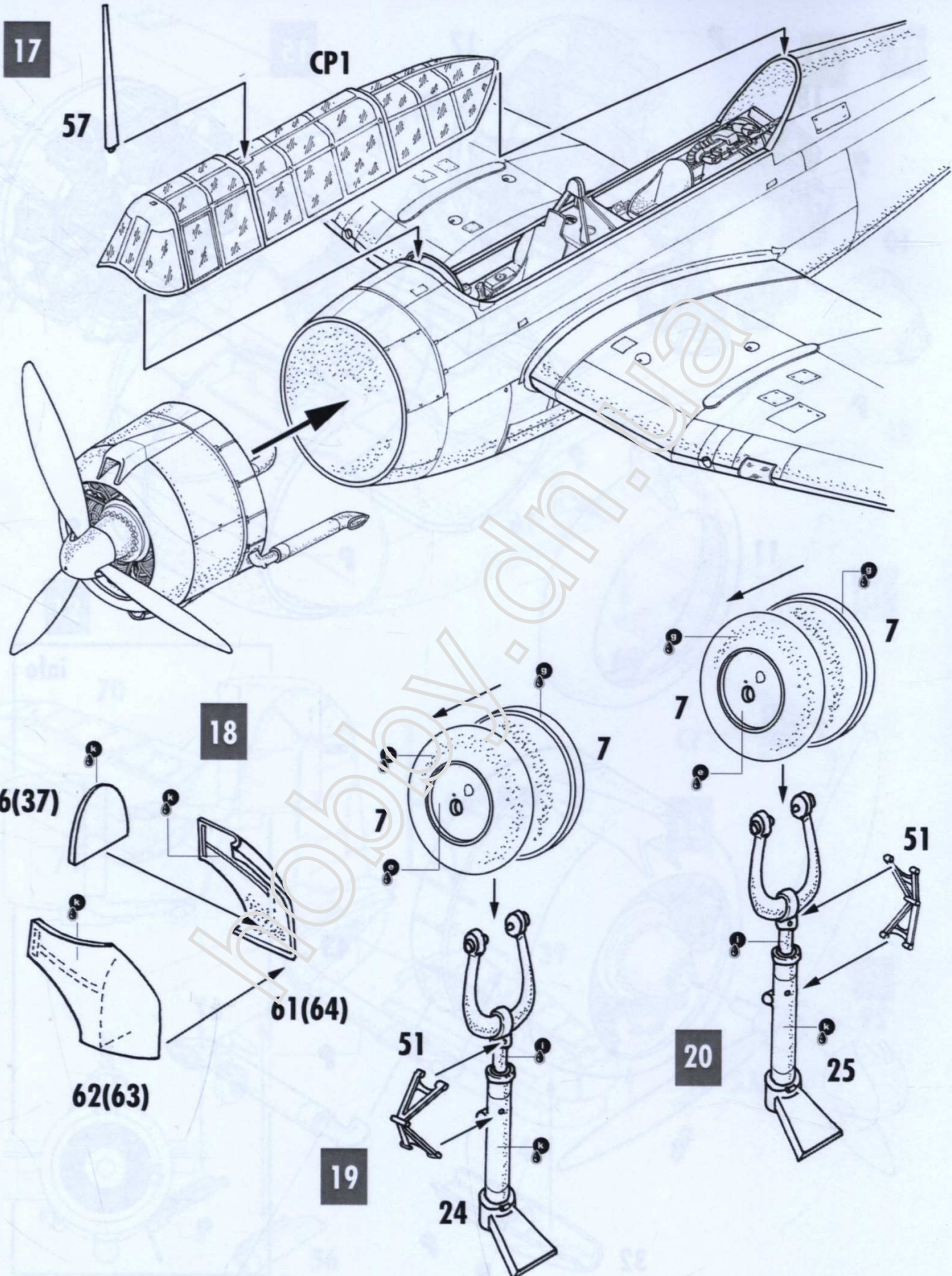

21

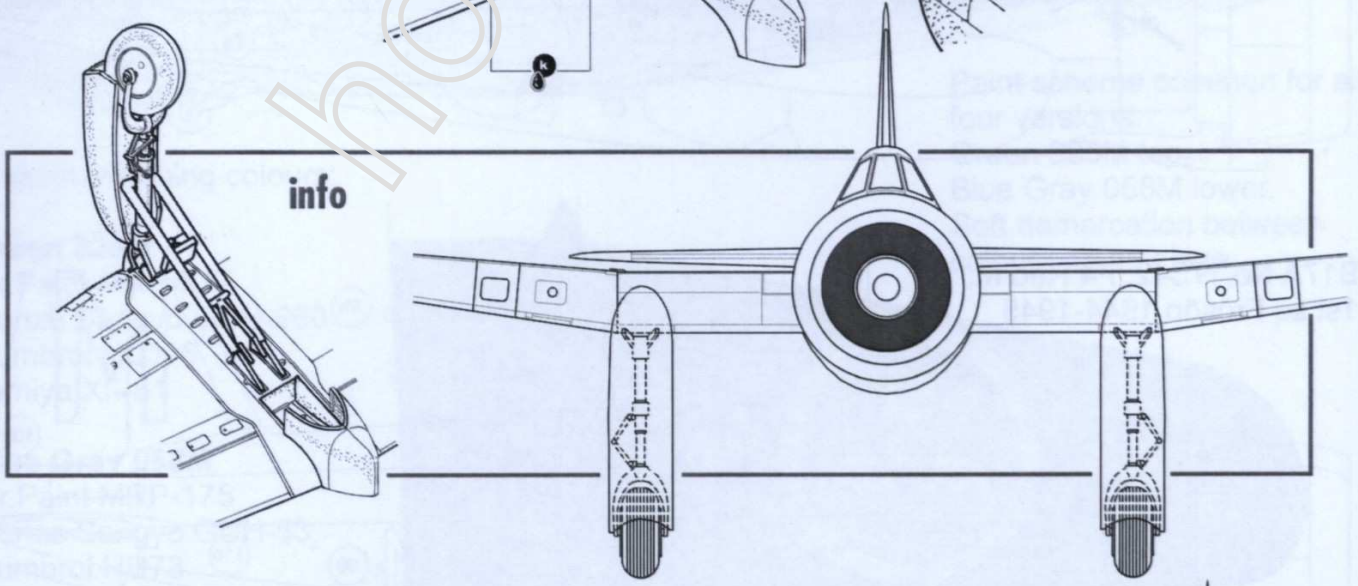
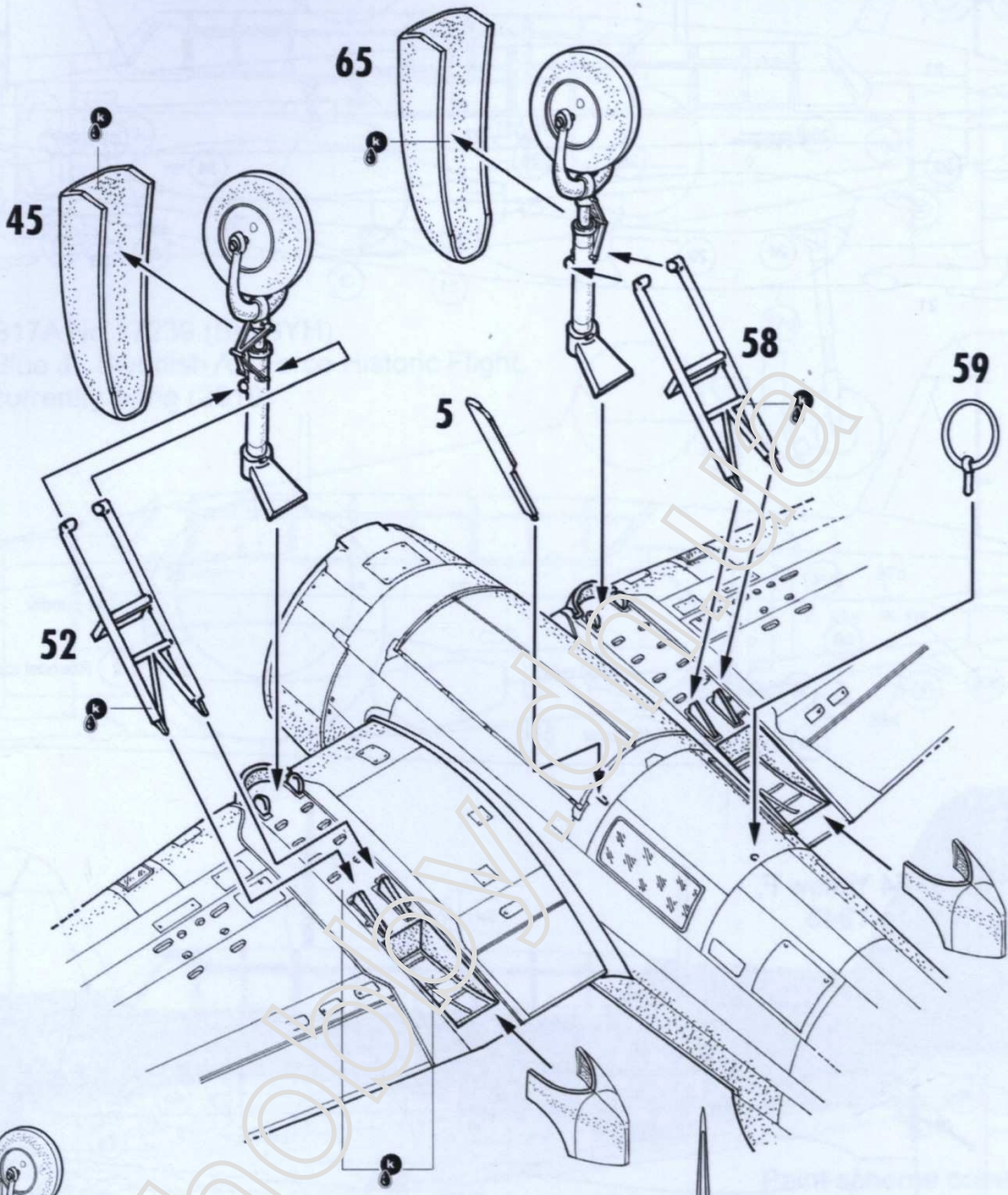

Stencilling common to all four versions. Note! Check each profile for individual stencils.

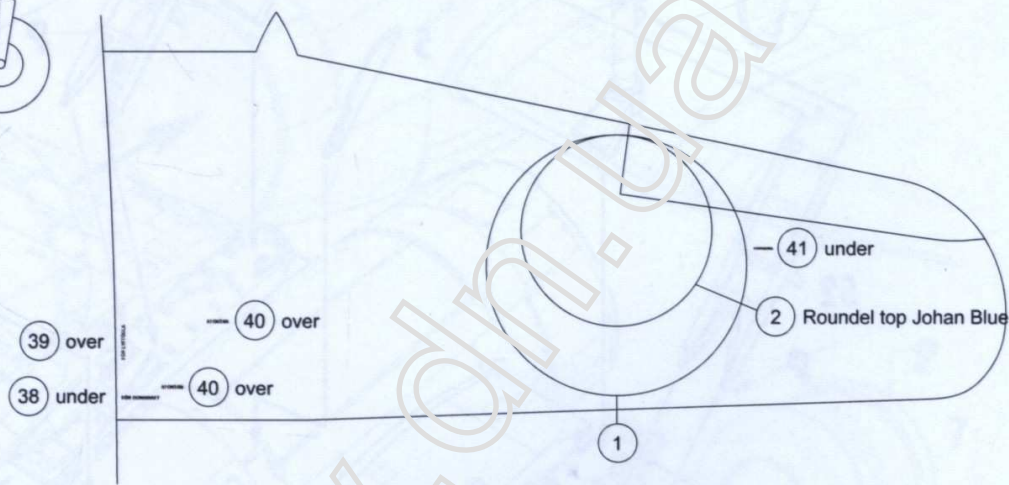
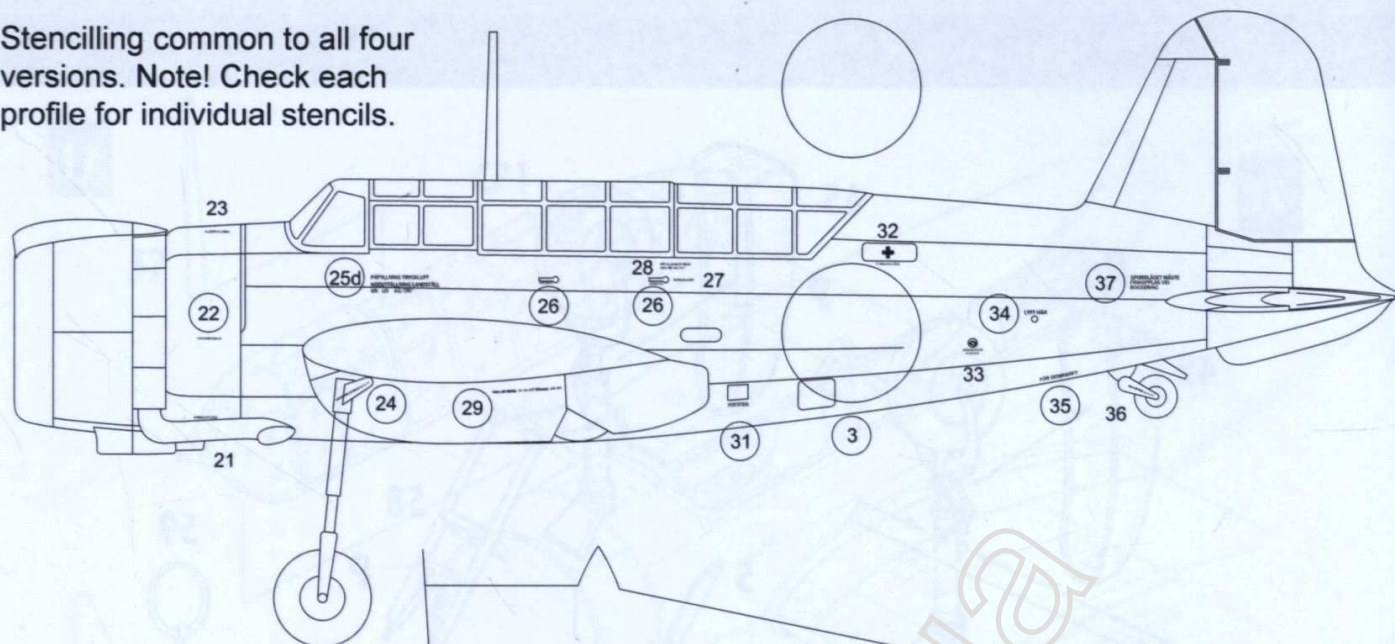

B17A No.17349, F4 Yellow F,
3rd sq Frösön 1944-1945

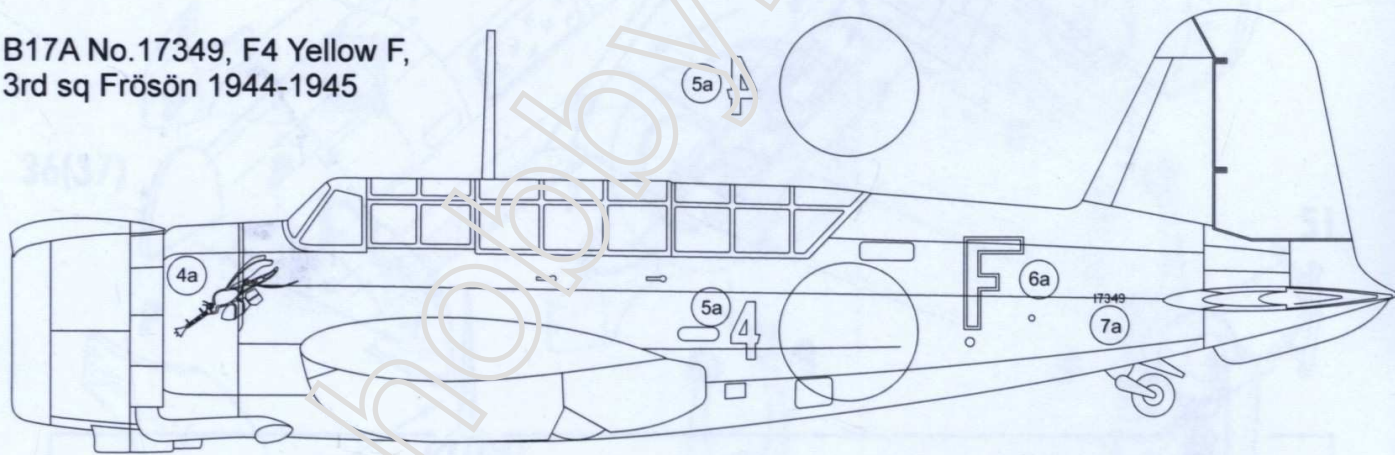

B17A No.17342, F4 Red M,
1st sq Frösön 1944-1945

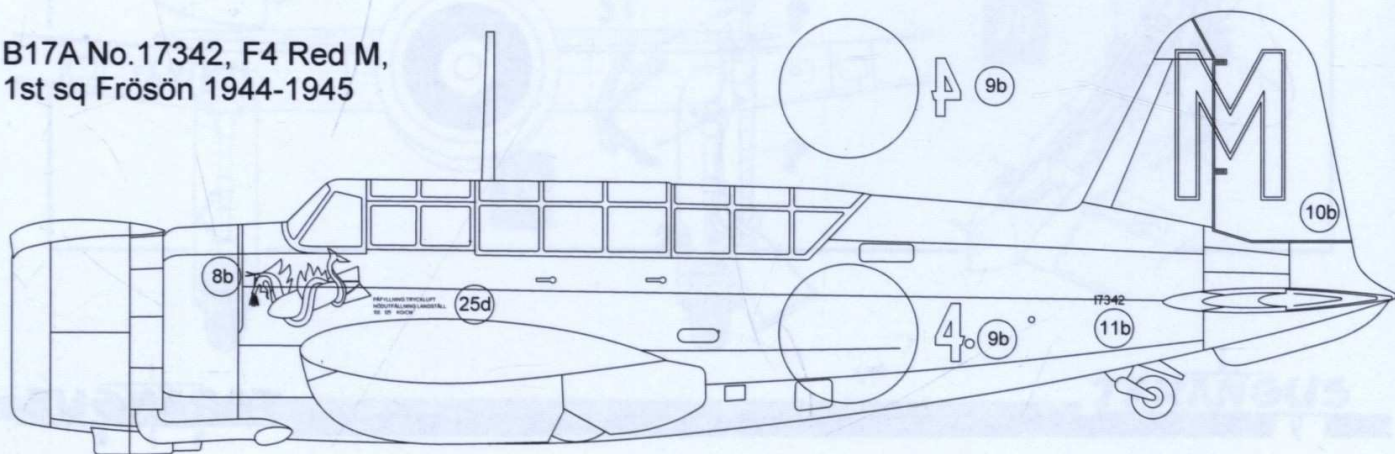

B17A No.17242, F6-35, 3rd sq
 Karlsborg 1944

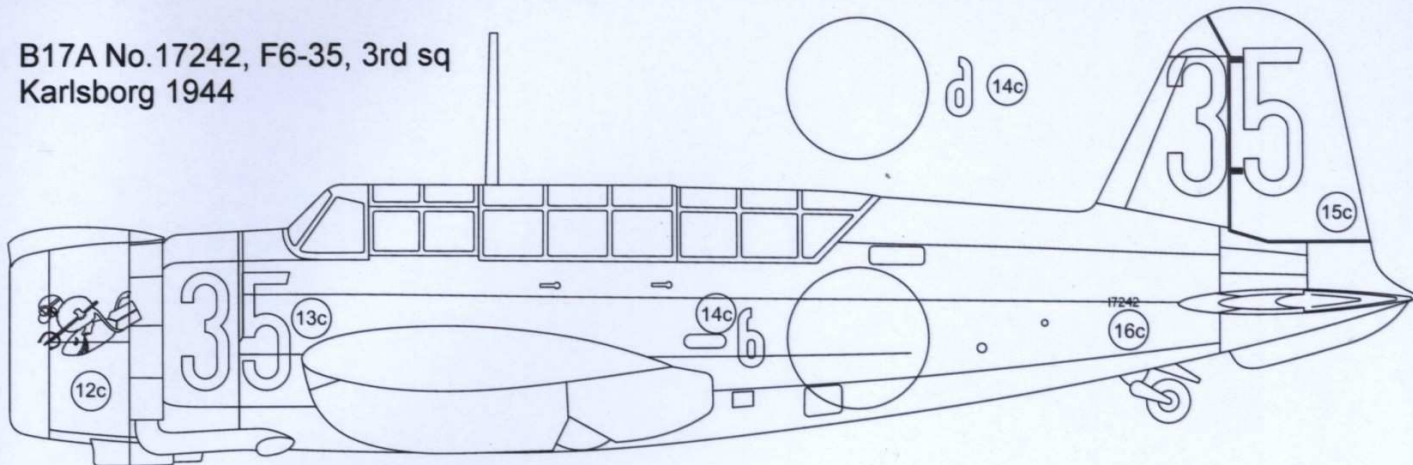

B17A No.17239 (SE-BYH)
 Blue J, Swedish Air Force Historic Flight,
 currently flying (2019)

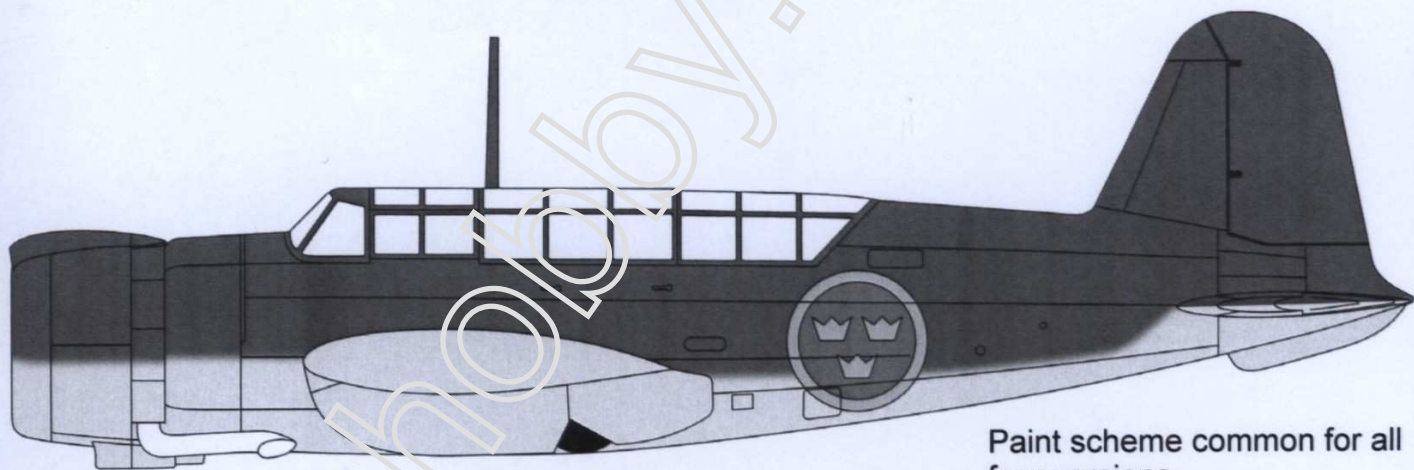
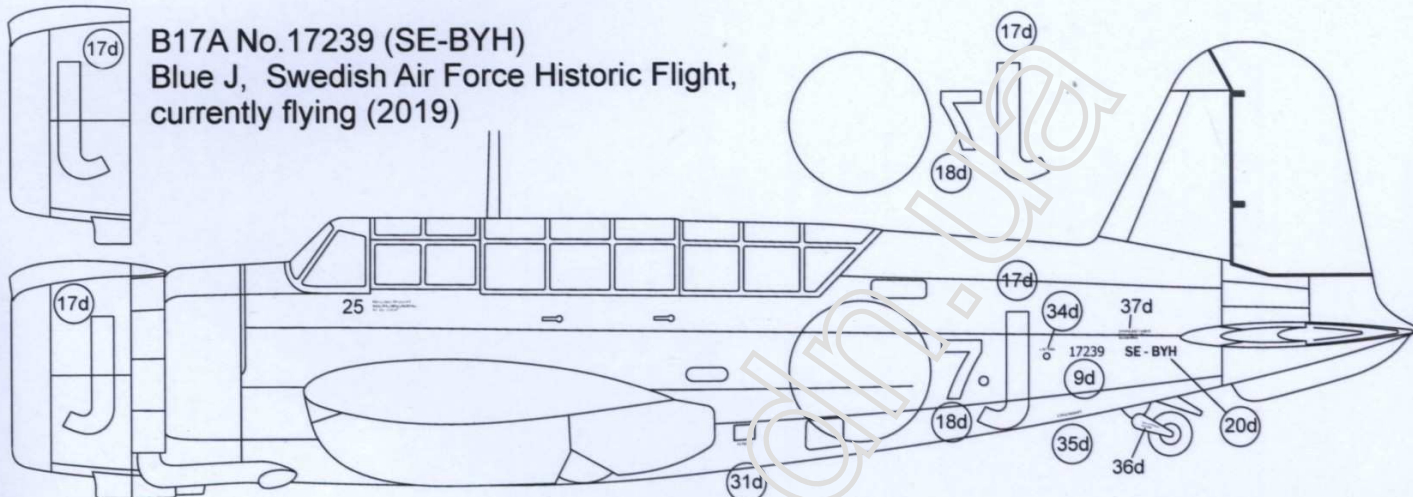

Paint scheme common for all
 four versions.
 Green 325M top
 Blue Gray 058M lower.
 Soft demarcation between
 colours on fuselage.

Closest matching colours:

Green 325M

- Mr.Paint MRP-217
- Gunze Sangyo GUH-060
- Humbrol HU116
- Tamiya XF-61

Blue Gray 058M

- Mr.Paint MRP-175
- Gunze Sangyo GUH-53
- Humbrol HU73
- Tamiya XF-66/XF-53?

