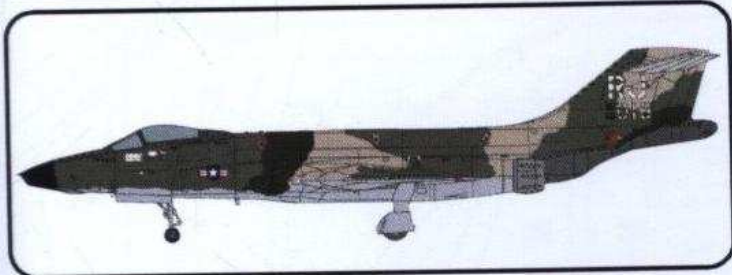

**72114 RF-101G/H Voodoo 1/72**

### Stručná historie

Po skončení druhé světové války dostala firma McDonnell zadání od Velitelství strategického letectva vyvinout dálkový doprovodný stíhací letoun. Z tohoto zadání vznikl letoun XF-88, který poprvé vzletl 29.10.1948. V roce 1950, kdy probíhaly letové zkoušky však Velitelství strategického letectva ztratilo o další vývoj tohoto letounu zájem a celý program zrušilo.

Ovšem už v roce 1951 v souvislosti s korejskou válkou byl program opětovně zahájen.

Letouny byly již nyní označeny jako F-101. Zároveň byl vznesen požadavek na dálkový průzkumný stroj pod označení RF-101. Zakázka na prvních 29 předseriových letounů byla dána v roce 1953. F-101 se od prototypů XF-88 lišily prodlouženou příďí a hlavně novým motorem Pratt & Whitney J57-P-13 s přidavným spalováním o tahu 64,47 kN. 29. září 1954 provedl šéfpilot McDonnellu Robert C. Little první zálet letounu F-101A s bojovým označením Voodoo.

Ukončením korejské války však Velitelství strategického letectva opětovně ztratilo o tyto stroje zájem. Zakázku však převzalo Velitelství taktického letectva. První sériový stroj z 50 kusové série byl zařazen do operační služby až v květnu 1957. Původní výzbroj byly tvořena čtyřmi kanóny M-39 ráže 20 mm, třemi PLRS AIM/4A Falcon a dvanácti neřízenými raketami 70 mm. Pod trupem mohla být zavěšena též taktická jaderná puma.Voodoo byl ve své době nejrychlejším samostatným bombardovacím letounem.

Od 51 vyrobeného kusu nesl letoun označení F-101C. Byl konstrukčně zesílen drak letounu pro činnost v nízkých výškách. Letounů F-101C bylo vyrobeno 47 kusů, které byly součástí výzbroje 81. taktického stíhacího křídla.

Z dvou předseriových letounů F-101A byly v roce 1956 upraveny letouny pro dálkový průzkum. Ve zkosené příďi bylo možno umístit čtyři až šest kamer pro denní i noční snímkování. Průzkumných letounů bylo vyrobeno 35 kusů ve verzi RF-101A a 166 kusů ve verzi RF-101C. Letouny RF-101 byly neozbrojené a spoléhaly jen na svou rychlost. Tato výhoda však byla ztracena při fotografování cíle kdy musela být rychlost snížena a tak docházelo k velkým ztrátám od protiletectvé obrany. Od roku 1961 byly letouny RF-101C operačně nasazené v jihovýchodní Asii, kde působily až do roku 1970 v rámci operací ve vietnamské válce. Od roku 1965 byly postupně nahrazovány novými letouny RF-4C Phantom.

Po vyřazení sloužily letouny Voodoo ve výzbroji letek Letecké národní gardy. Zde byly letouny modifikovány na verze G a H s odlišným tvarování příďe s fotografickou výzbrojí.. Jediným exportem těchto strojů byl prodej 25 kusů do Tchajwanu.

Celkem bylo vyrobeno 327 jednomístných letoun F/RF-101 Voodoo.

### Technická data:

Rozpětí (m)	12,09
Délka (m)	21,1
Výška (m)	5,49
Max. rychlost (km/hod)	1825
Dolet max. (km)	2450
Dostup (m)	17800

**VALOM**  
Zlešická 1808/10 148 00 Praha 4 - Chodov  
Czech Republic



### A Brief History

Following the Second World War, McDonnell was commissioned by Strategic Air Command to develop a long-range escort fighter. This resulted in the XF-88 fighter, which first flew on 29<sup>th</sup> October 1948. However, after flight tests were conducted in 1950, Strategic Air Command no longer felt the need for further development of this type of fighter and cancelled the entire program.

However, in 1951 the program was restarted due to the Korean War. The fighters had now been renamed the F-101 and when, a requirement was issued for a long-range reconnaissance plane, the RF-101 was born. The order for the first 29 pre-production planes was made in 1953. The F-101 differed from the prototypes by its prolonged nose and particularly the new Pratt & Whitney J57-P-13 engines with an afterburner thrust of 64.47 kNt. On 29<sup>th</sup> September 1954, McDonnell chief pilot Robert C. Little flew the first test flight of the F-101A fighter under the fighting name of Voodoo.

After the end of the Korean War, Strategic Air Command once again became disinterested in these aircraft. However, the order was taken over by Tactical Air Command and the first plane from a series of 50 aircraft was commissioned into operational service in May 1957. The original armament consisted of four 20 mm calibre M-39 cannons, three MLD AIM/4A Falcon rockets and twelve 70 mm unguided rockets. A tactical nuclear bomb could also be hung under the fuselage. At that time, the Voodoo was the fastest fighter-bomber aircraft in service.

After the 51<sup>st</sup> plane was manufactured, it was renamed as the F-101C. The airframe was structurally reinforced for operations at low altitudes. A total of 47 F-101C aircraft were manufactured and formed part of the armament of the 81st Tactical Reconnaissance Wing.

The two pre-production F-101A planes were modified for long-haul reconnaissance. Between four and six cameras for day and night photography could be placed in the chamfered nose. Altogether, 35 reconnaissance aircraft were manufactured in the RF-101A version and 166 in the RF-101C version. The RF-101 planes were unarmed and relied solely on speed. However, this advantage was lost while photographing the target, as the speed had to be reduced, which resulted in large losses from anti-aircraft defences. From 1961, the RF-101C were deployed for operations in south-eastern Africa where they remained until 1970 for use in operations in the Vietnam War. They were gradually replaced from 1965 by the new RF-4C Phantom aircraft.

After withdrawal, the Voodoo planes served in the armament of the Air National Guard where the planes were modified into G and H versions with a different nose mould for housing the photographic armaments.

The only export of those aircraft was the sale of 25 planes to Taiwan. In total, 327 single-seat F/RF-101 Voodoo planes were manufactured.

### Technical Data:

Wingspan (ft)	39,6
Length (ft)	69,3
Height (ft)	18
Max. speed (mph)	1134
Range (mils)	1520
Ceiling (ft)	58400

Plastikové díly

Plastic Parts

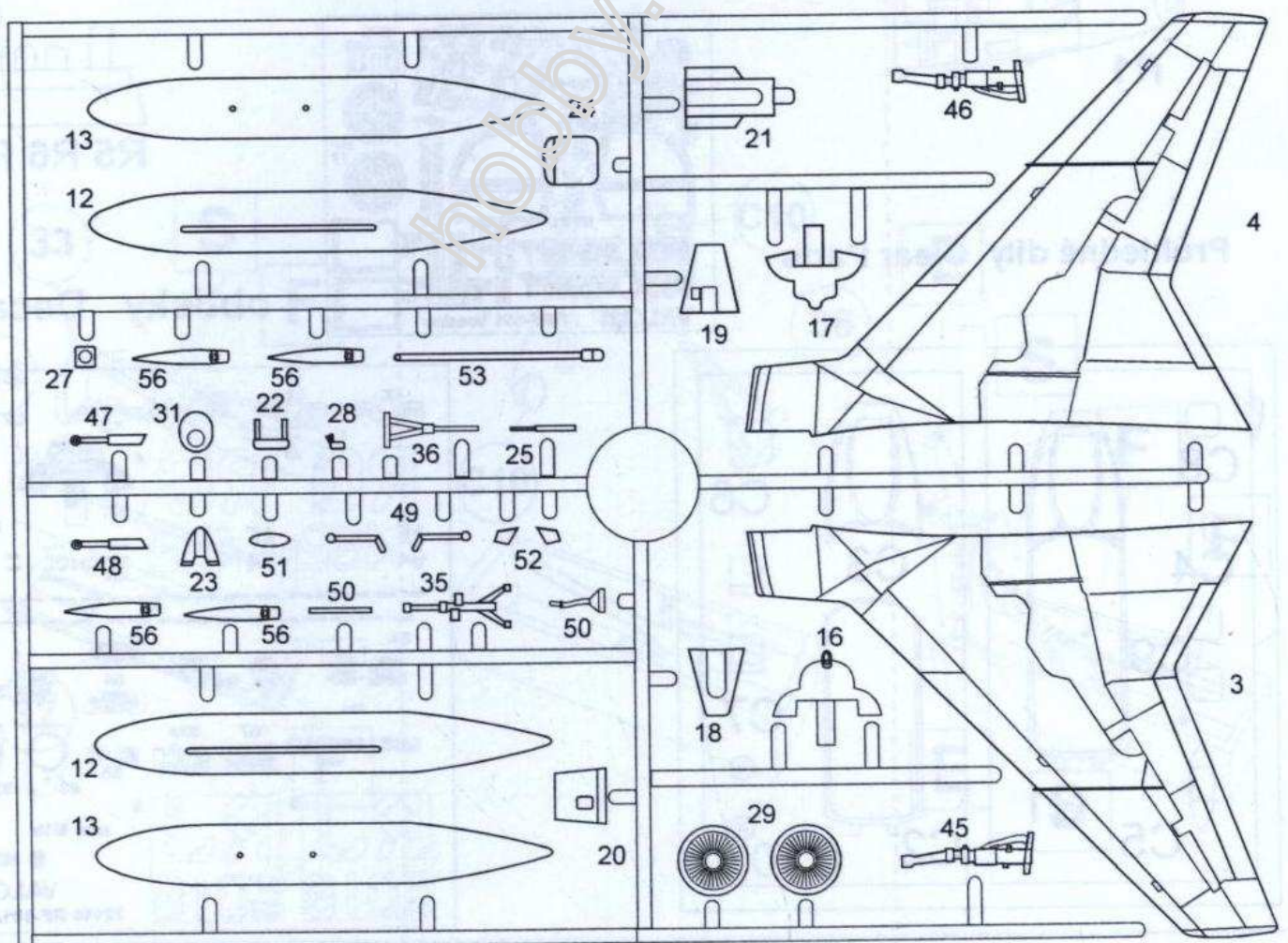
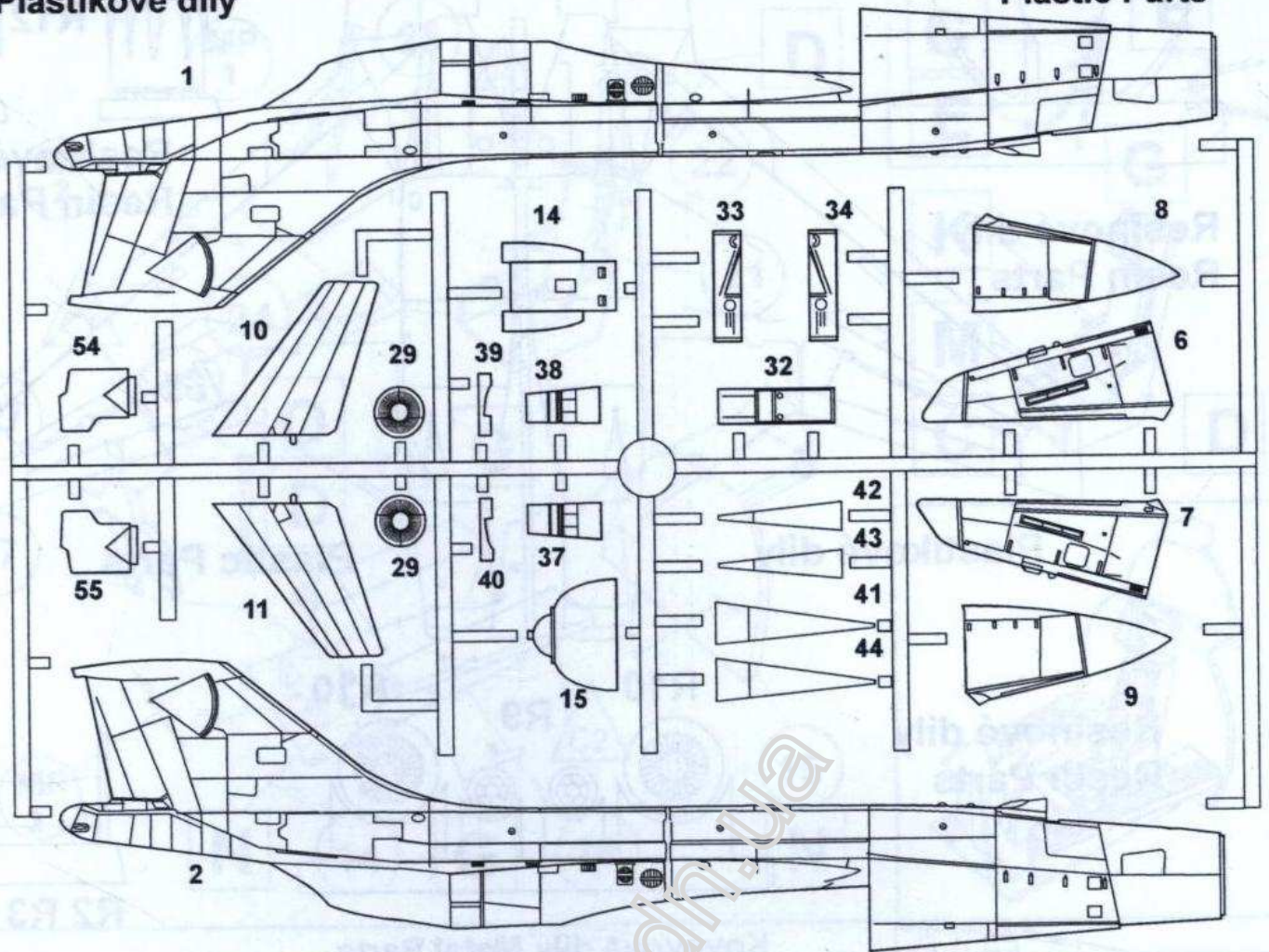

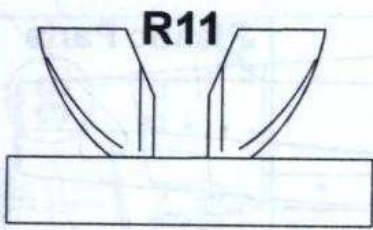

**Resinové díly  
Resin Parts**



**Resinové díly  
Resin Parts**

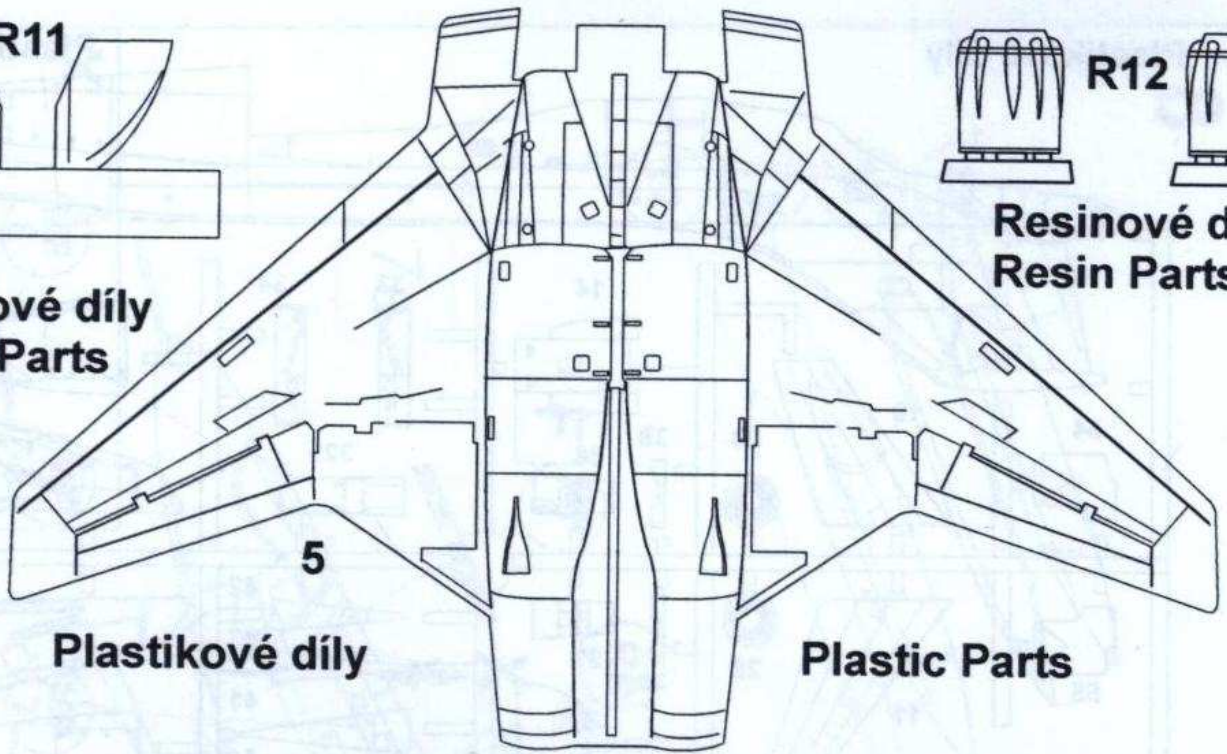

**Plastikové díly  
Plastic Parts**

**Plastic Parts**

**Resinové díly  
Resin Parts**

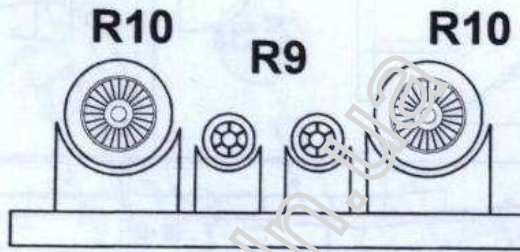

**Kovové díly  
Metal Parts**

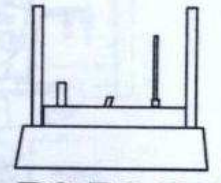

**R2 R3 R4**

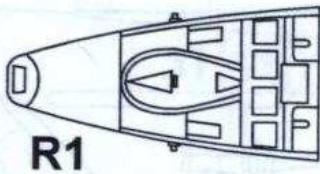

**R1**

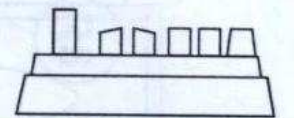
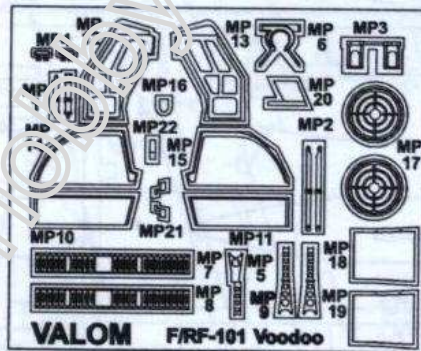

**R5 R6 R7 R8**

**Průhledné díly  
Clear Parts**

**obtisky  
Decals**

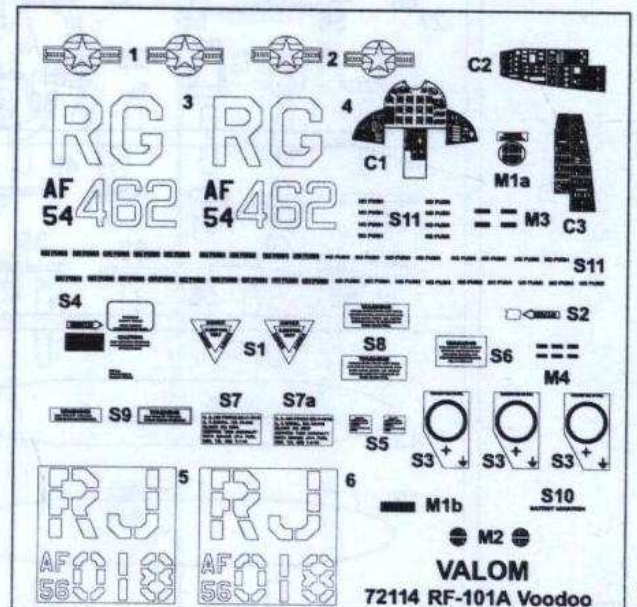
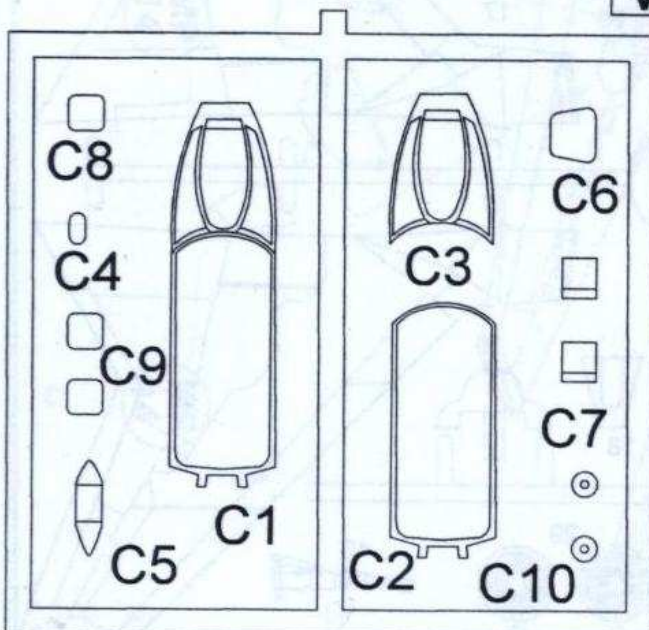

1

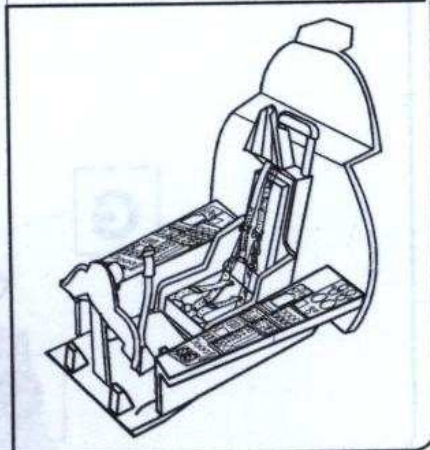
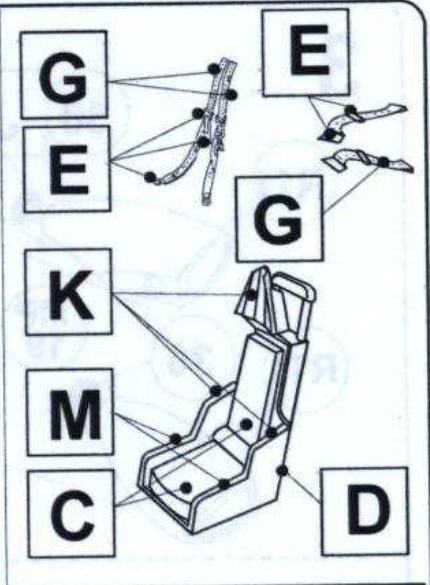
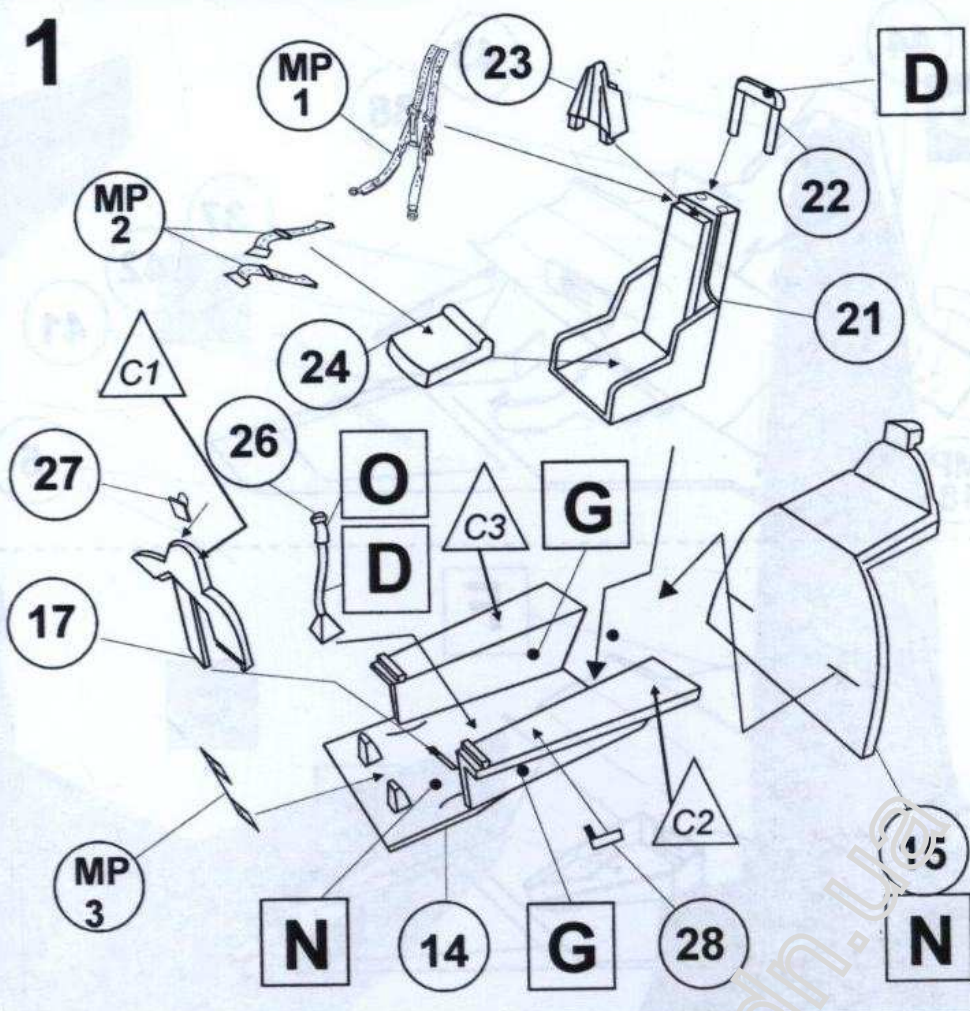

2

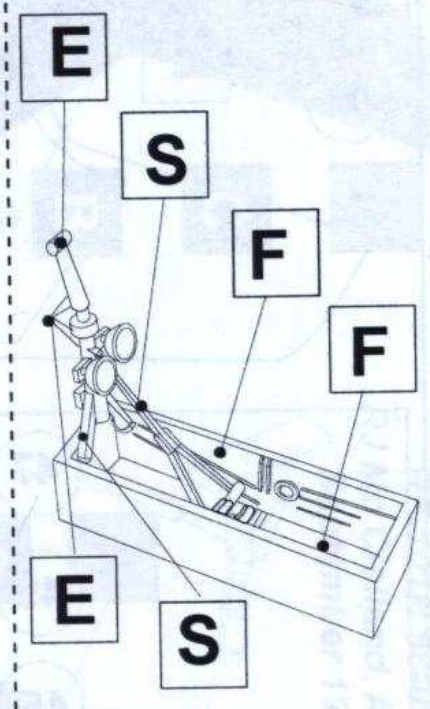
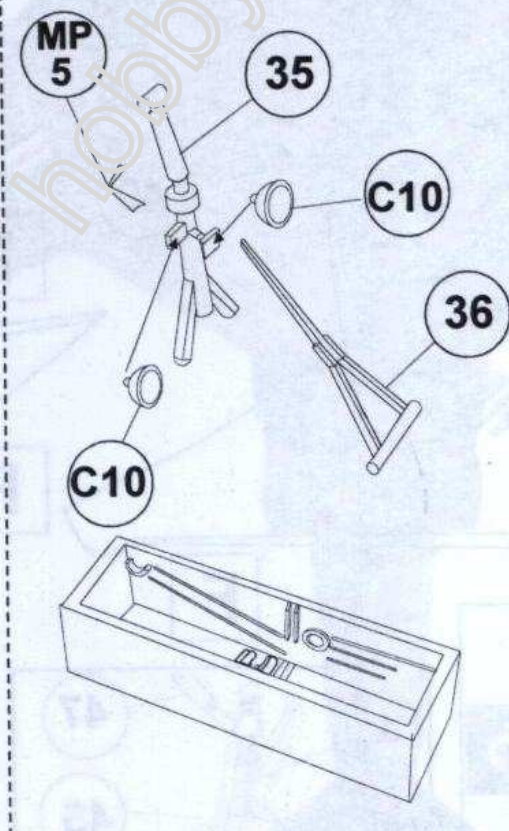
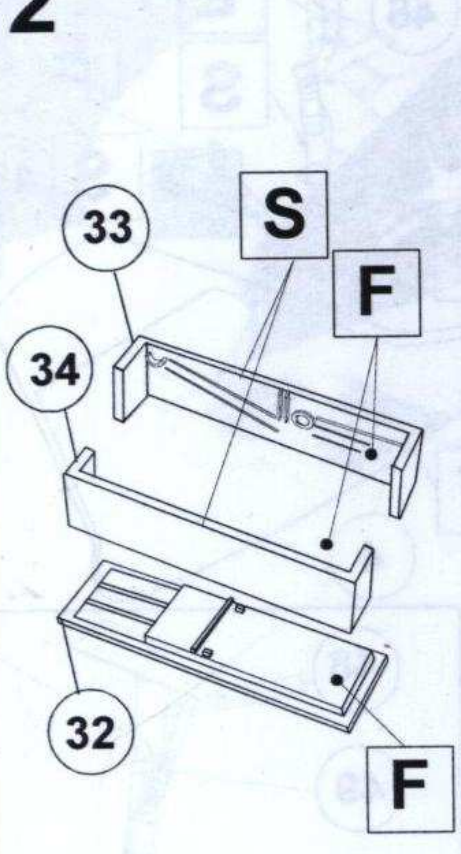

3

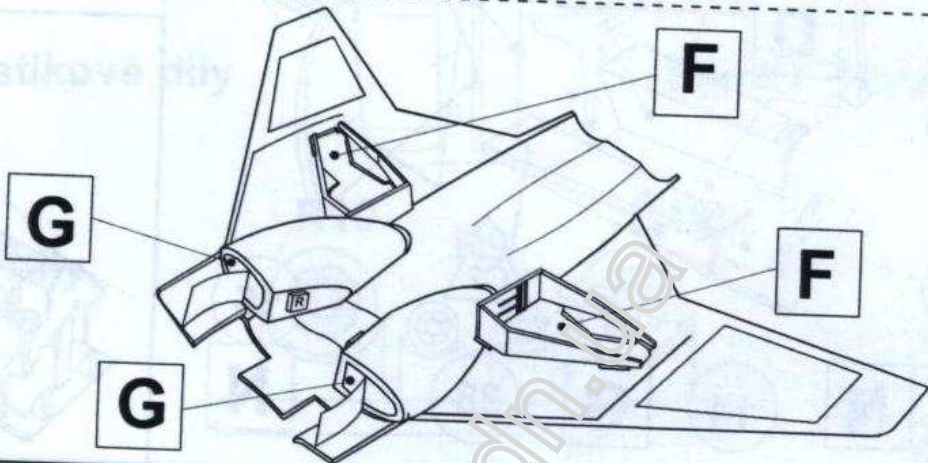
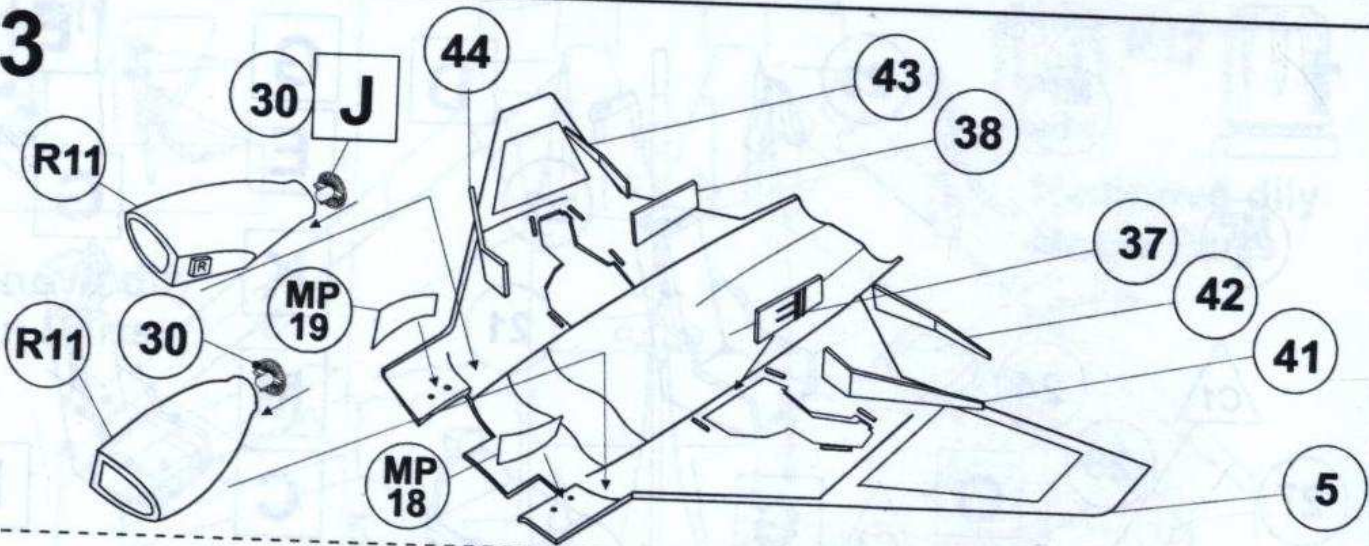

4

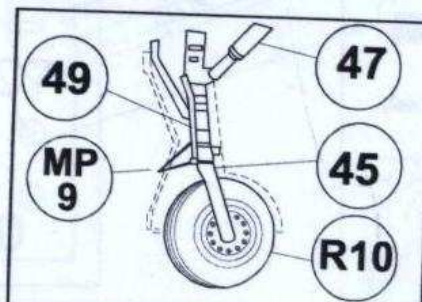
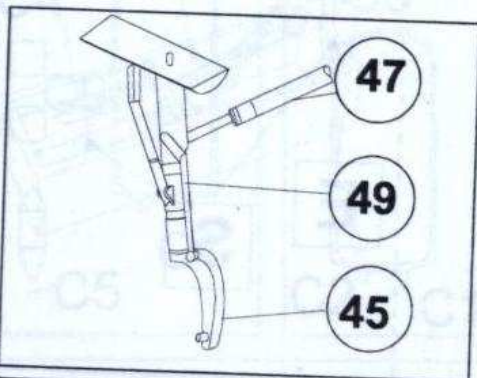
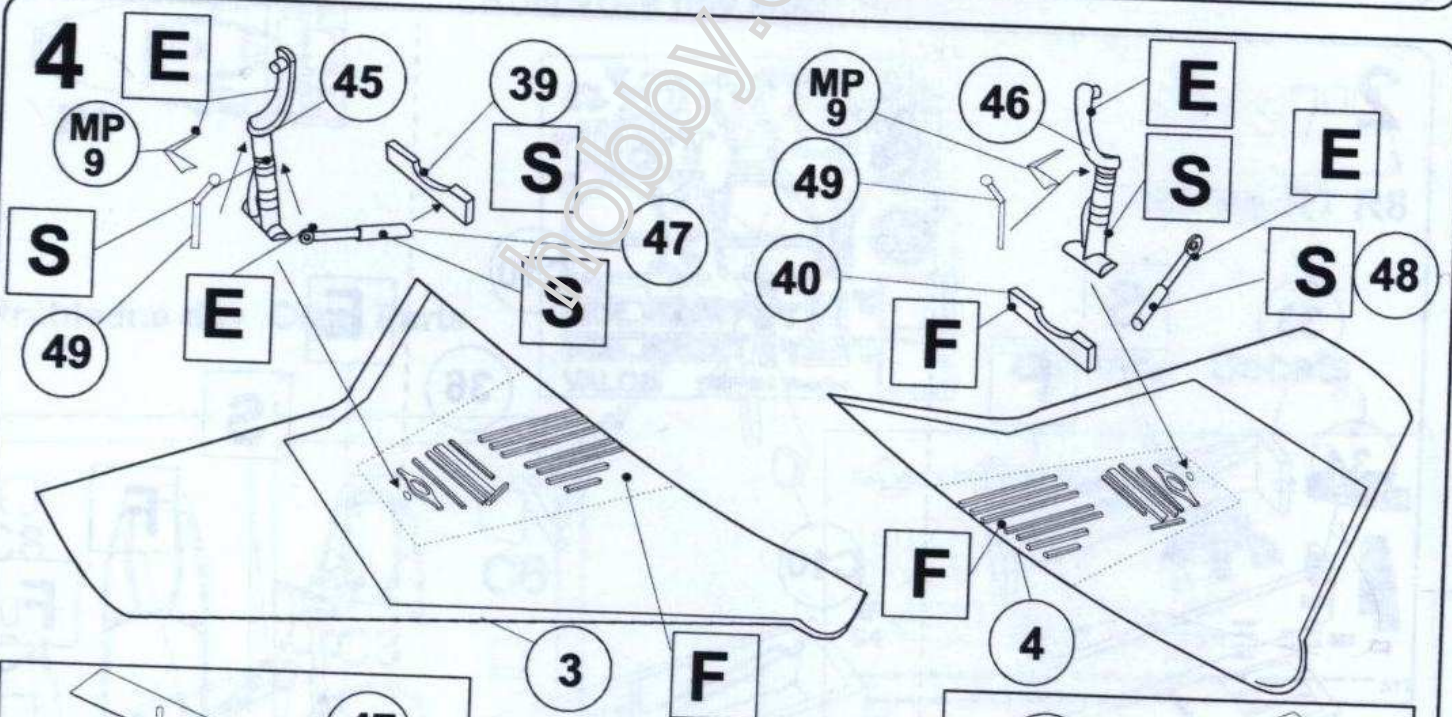

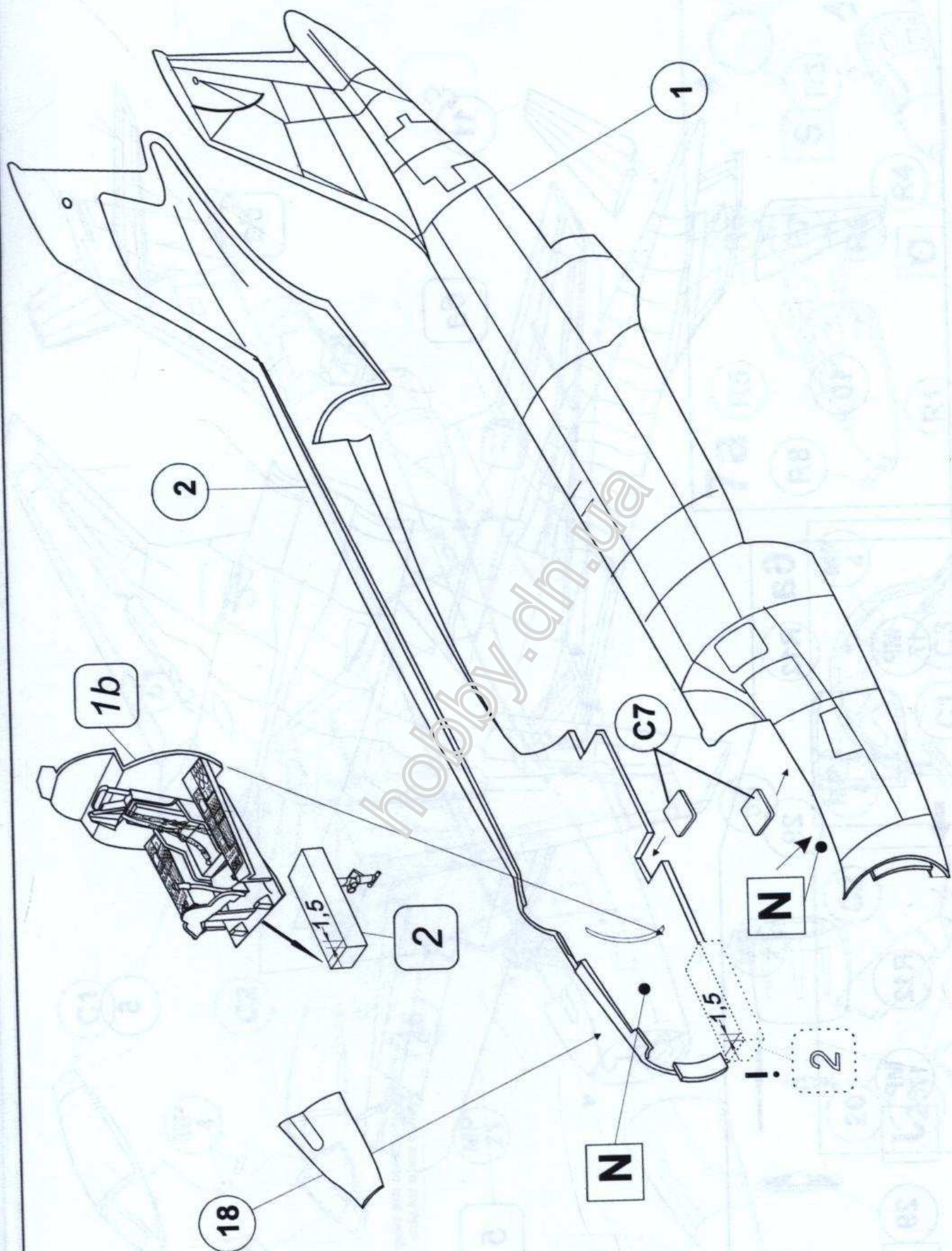

9

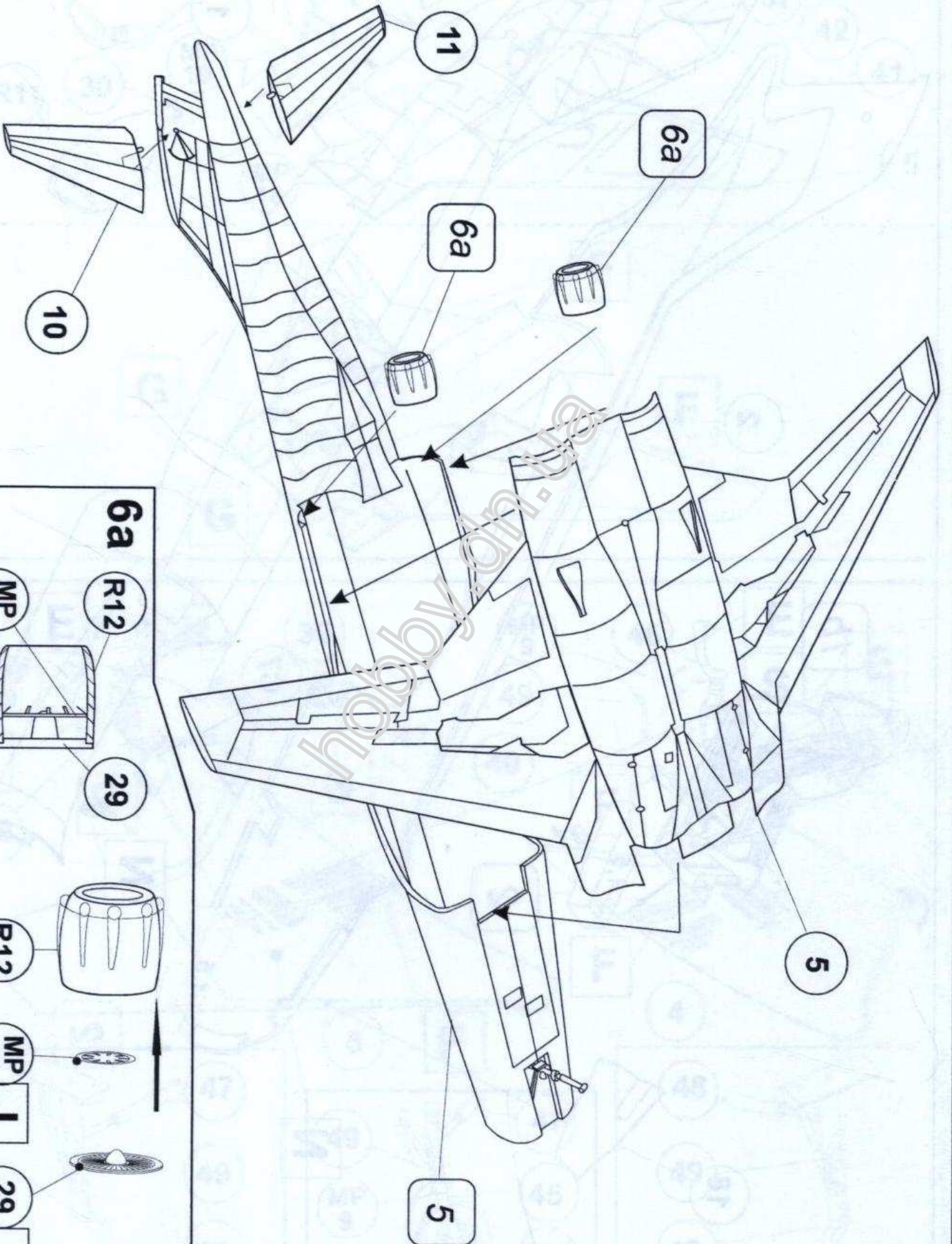

7

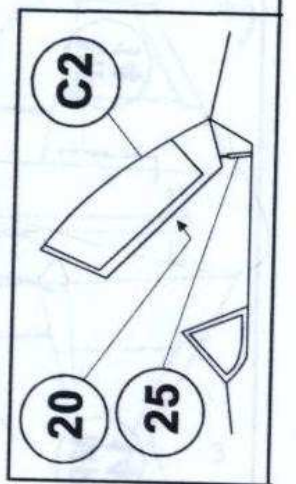
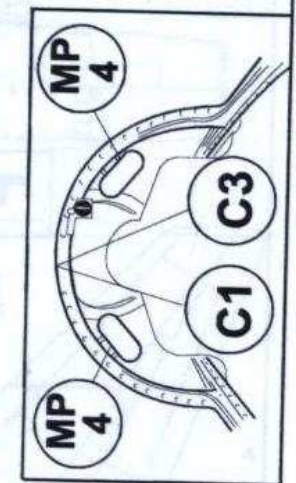
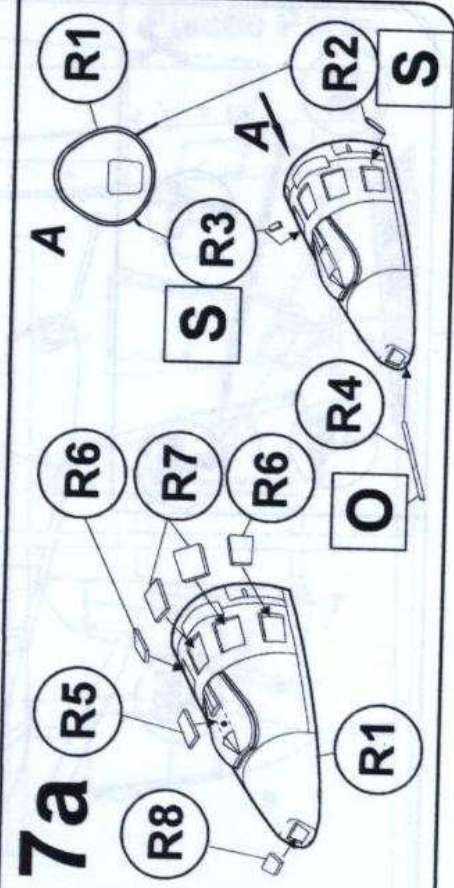
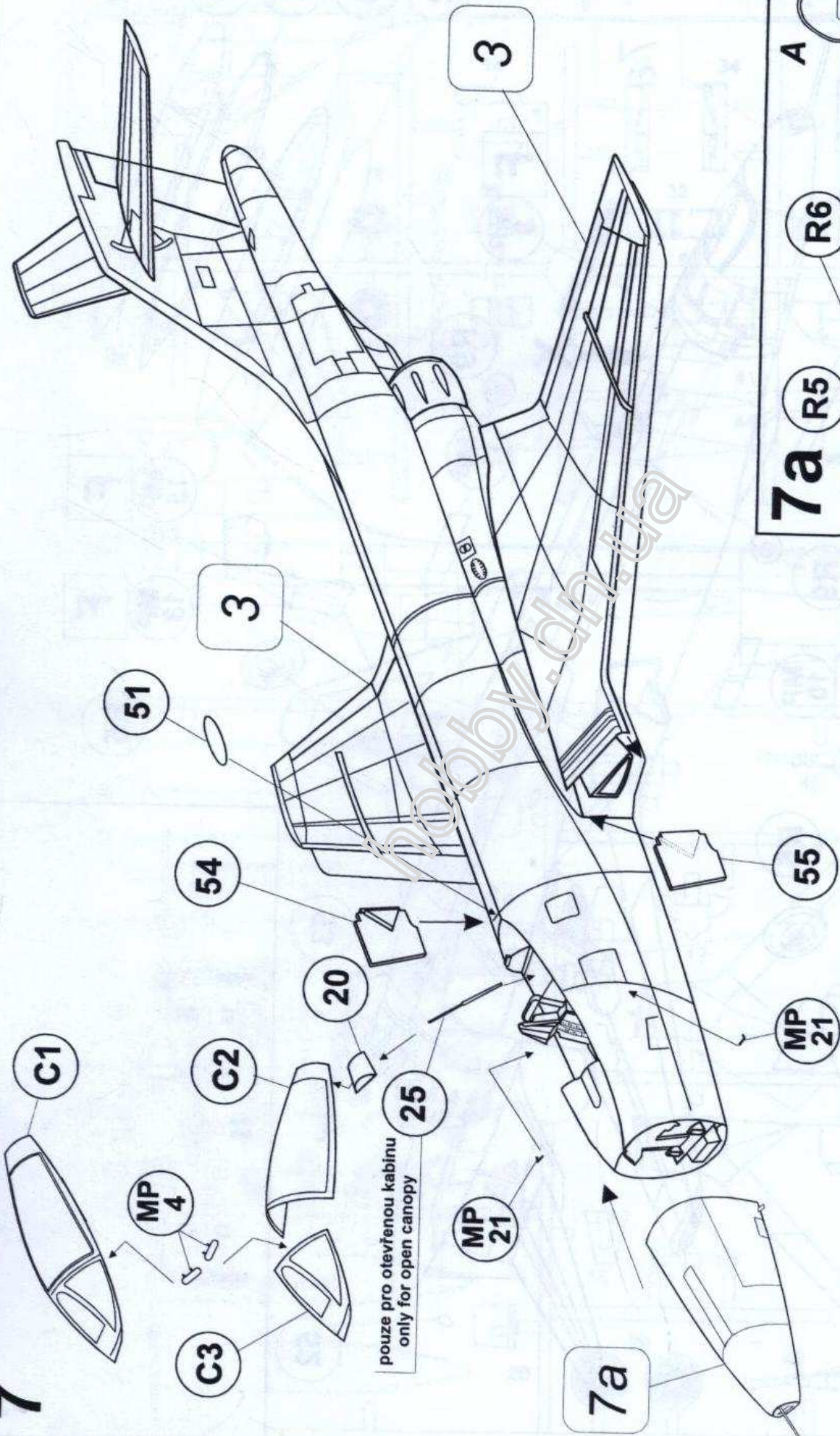



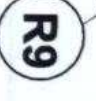
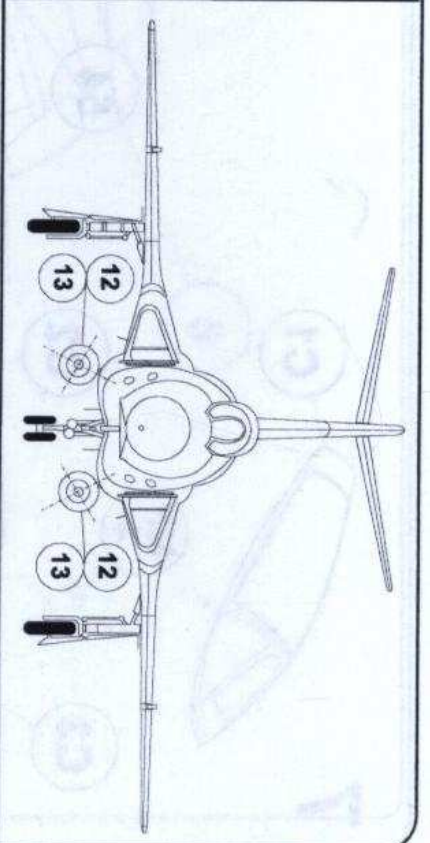
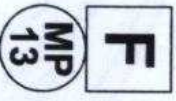
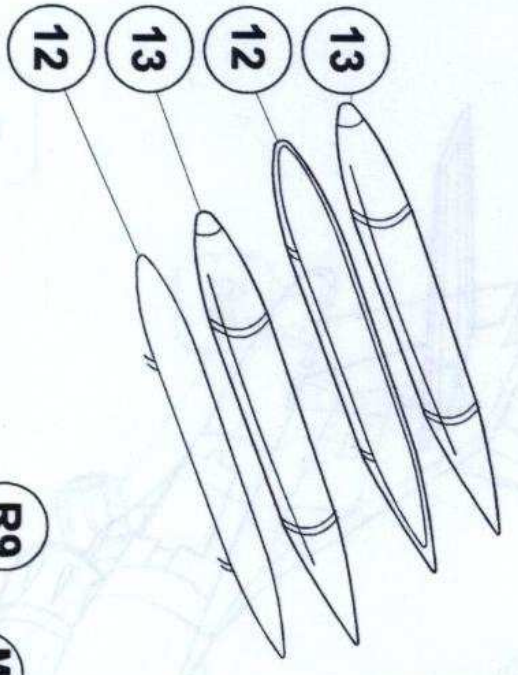

X

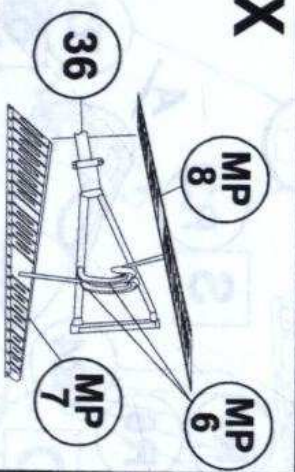

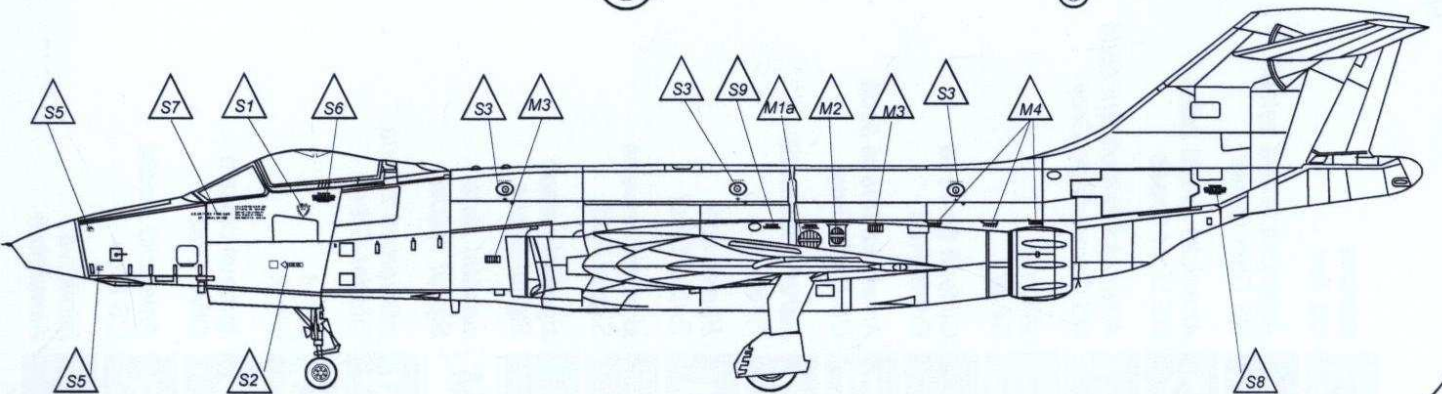
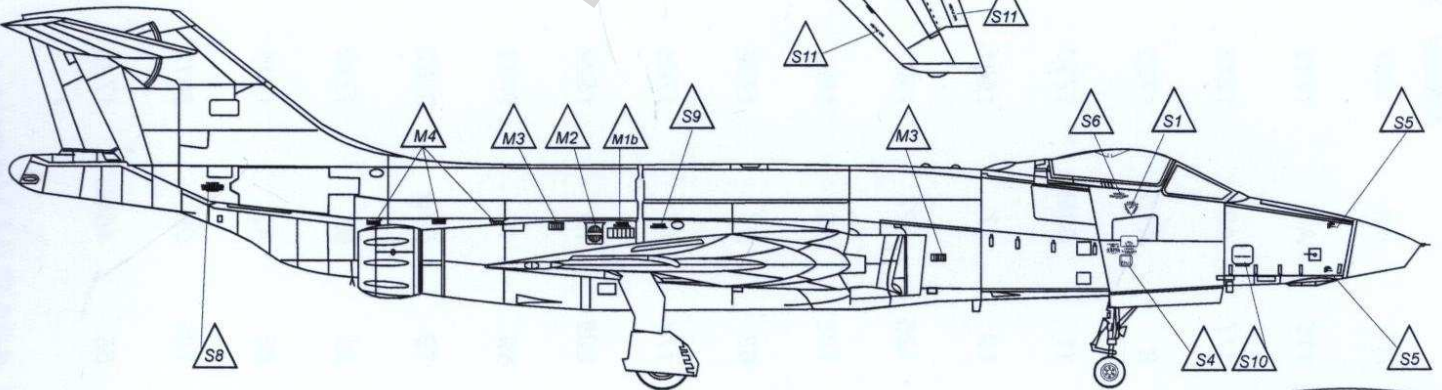
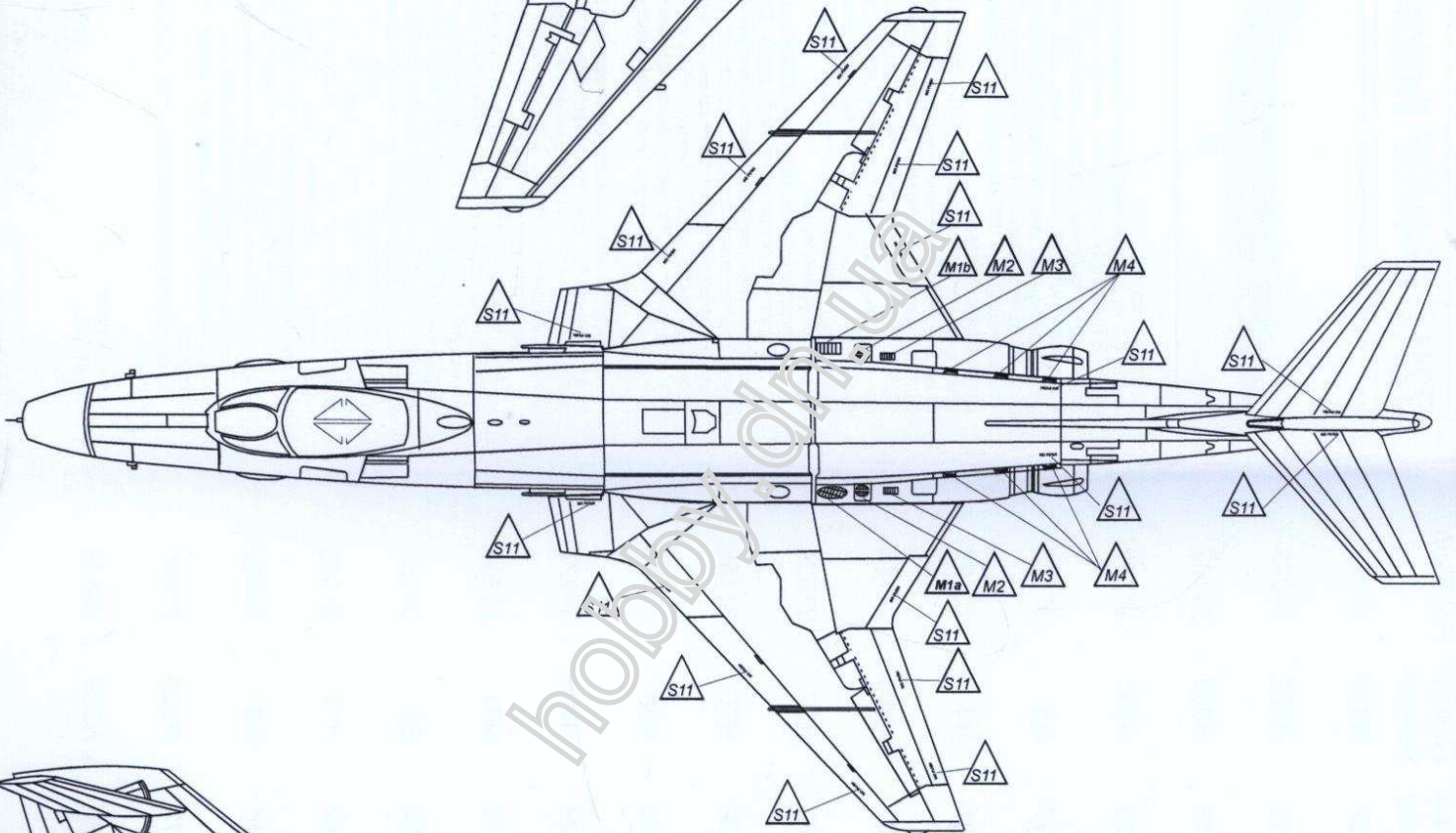
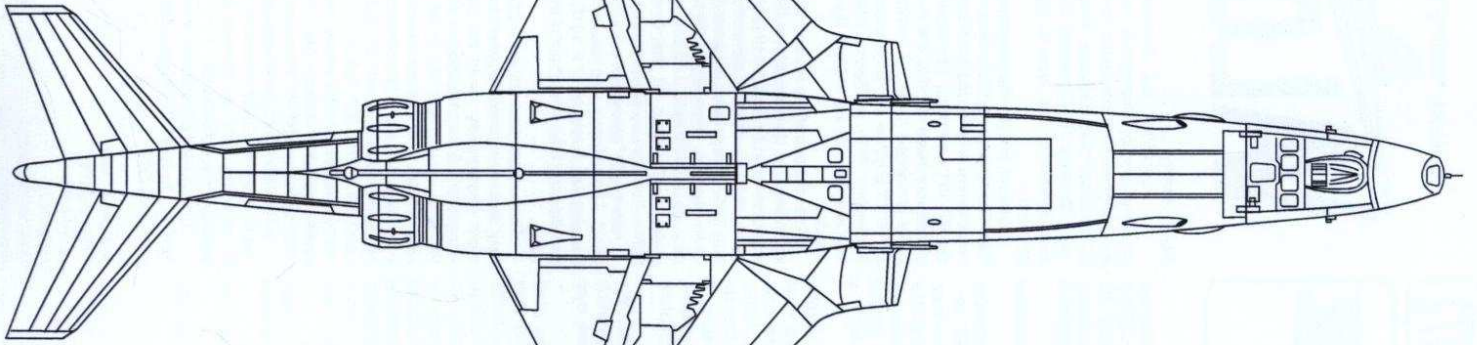

RF-101G 54-1462, 165 TRS, 165 TRW  
Kentucky  
Air National Guard (ANG), 1970



RF-101H 56-018,  
RJ Mc Clelland, AFB 28,  
September 1968

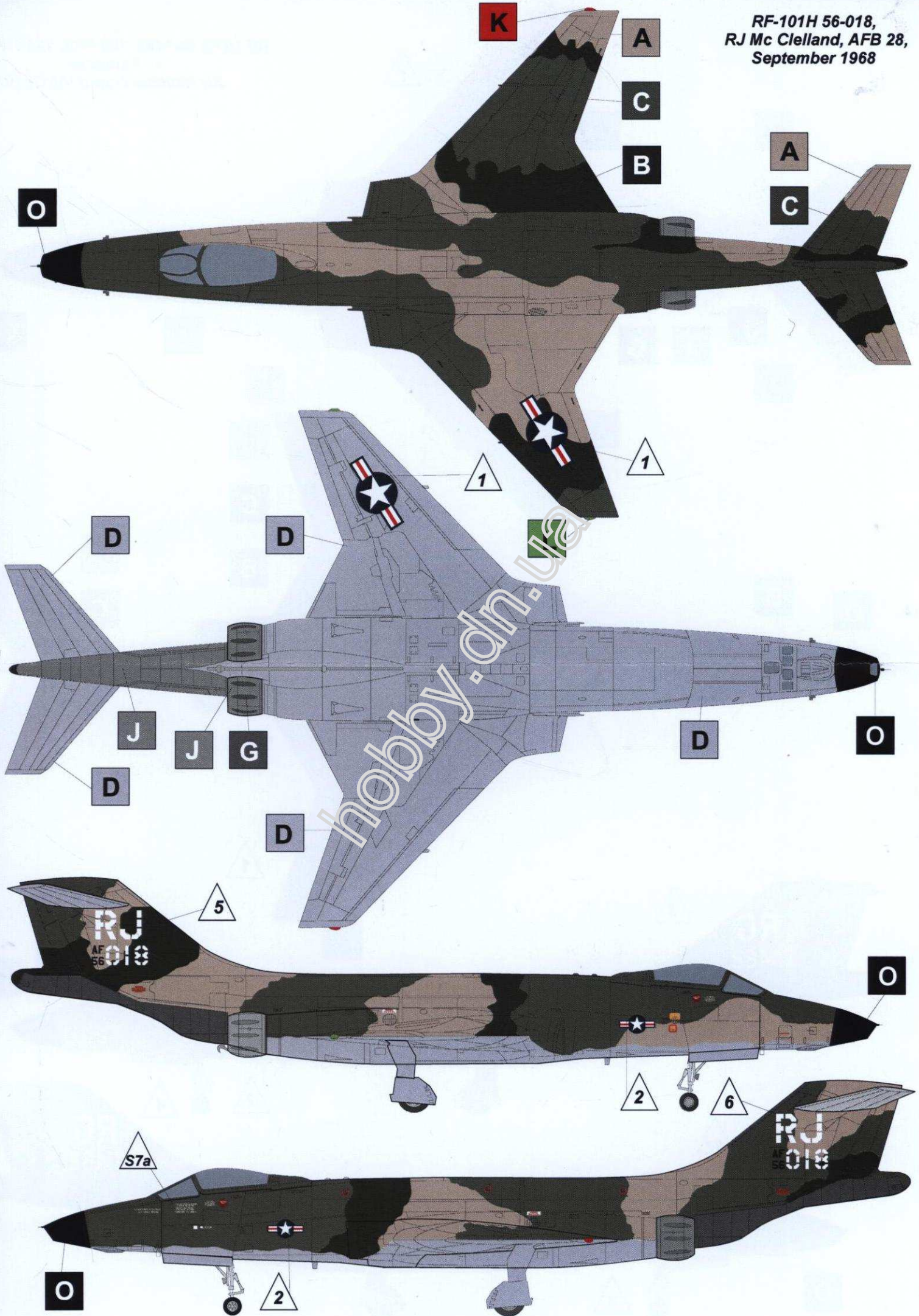

Humbrol Agama Model Gunze F.S.595b  
Master Sangyo

<b>A</b>	písková US Tan	119	Iz1	1567	H310	30219
<b>B</b>	Americká tmavá zelená US Dark Green	116	A7	1710	H309	34079
<b>C</b>	Americká světlá zelená US Light Green	117	A8	1913	H303	34102
<b>D</b>	Americká kamuflážní šedá US Camouflage Grey	8	A10	1733	H311	36622
<b>E</b>	stříbrná Silver	11	08Me	1790	H8	17178
<b>F</b>	Cihlově červená Bright Red	19	17	1501	H3	12199
<b>G</b>	Americká tmavá šedá US Dark Grey	125	A27	1923	H305	26118
<b>H</b>	Barva pneumatik Tyre	182	36	1592	H77	37030
<b>J</b>	žíhaná ocel Turbid Steel	63	57	1796	H76	34158
<b>K</b>	signální červená Signal Red	174	17	1705	H90	11310
<b>L</b>	signální zelená Signal Green	208	19	1524	H94	34227
<b>M</b>	signální žlutá Signal Yellow	69	15	2717	H91	13591
<b>N</b>	interierová zelená Interior Green	78	B10	2062	58	34151
<b>O</b>	černá Black	33	07	1749	H12	37028
<b>P</b>	špinavá olivová Olive Drab	66	A2	1711	H8	34087
<b>R</b>	Americká modrá US Blue	109	09	2012	H323	25095
<b>S</b>	hliníková Aluminium	56	46Me	1789	H339	17178

**X** obtisk  
Decal

**RF-101G/H Voodoo**