

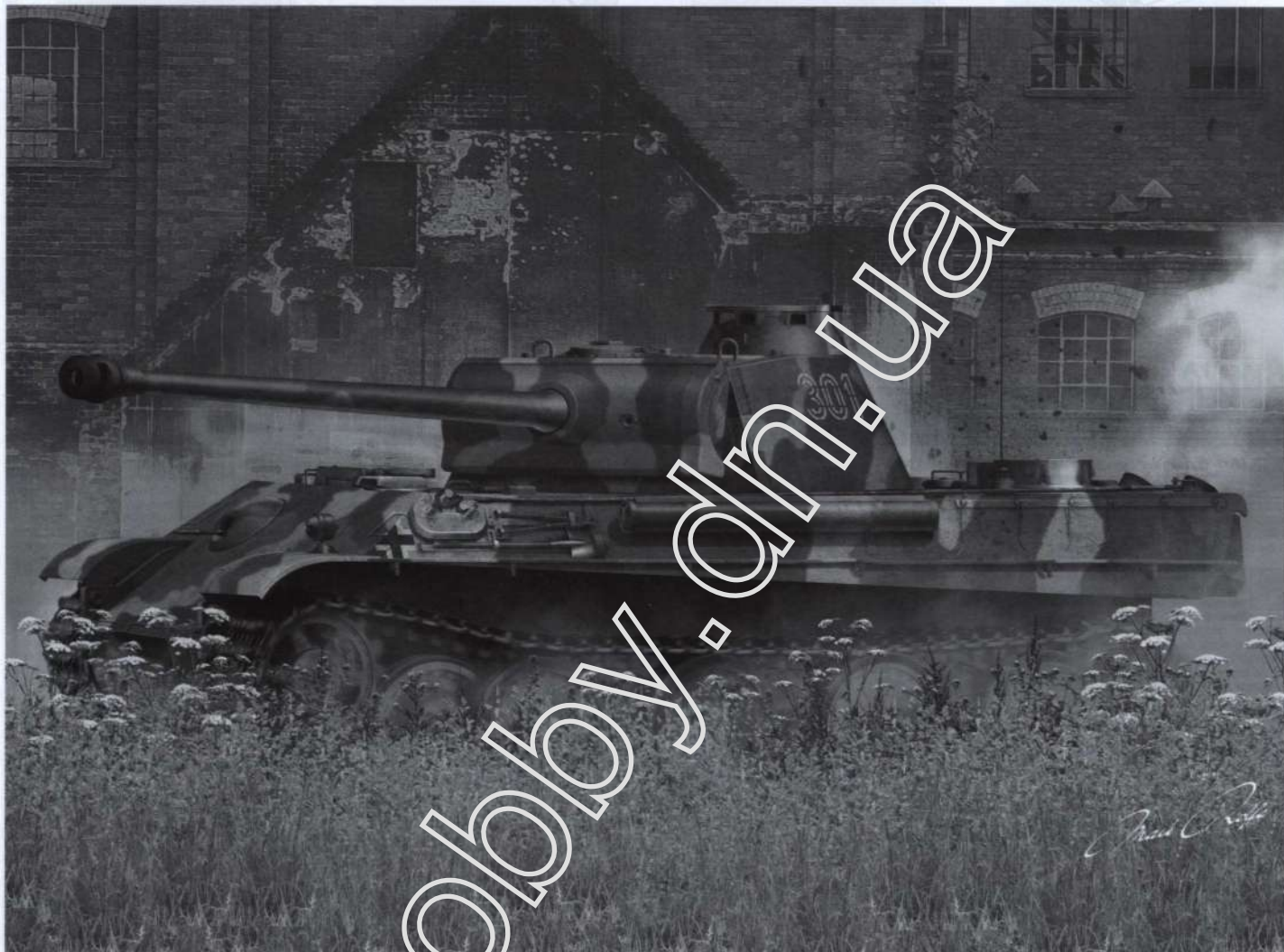

1:35 Panther Ausf.G

A1352 SCALE MODEL CONSTRUCTION KIT



On 3rd April 1944, M.A.N. reported that it had successfully completed trial production runs of the new Ausf.G chassis. M.A.N. built about 1143 Panther Ausf.G tanks between March 1944 and April 1945. Between July 1944 to March 1945 M.N.H. constructed 806 Panther Ausf.G tanks. Daimler-Benz finished 1004 Panther Ausf.G tanks between May 1944 and April 1945.

There were some minor differences between factory built tanks. M.N.H. fitted a cast steel Gleitschuh skid shoes instead of a rubber tire return roller behind the front track drive sprocket. The other two factories continued to fit rubber rimmed return rollers.

**HORNBY
HOBBIES**

FOR BEST RESULTS:

Surfaces to be painted should be clean – before parts are removed from the sprue, wash in warm, soapy water, rinse and dry thoroughly. Stir paints thoroughly before use.

PLEASE NOTE:

Some parts in the kit may not be required to build the model specified.

6

REFERENCE
SIDE VIEW

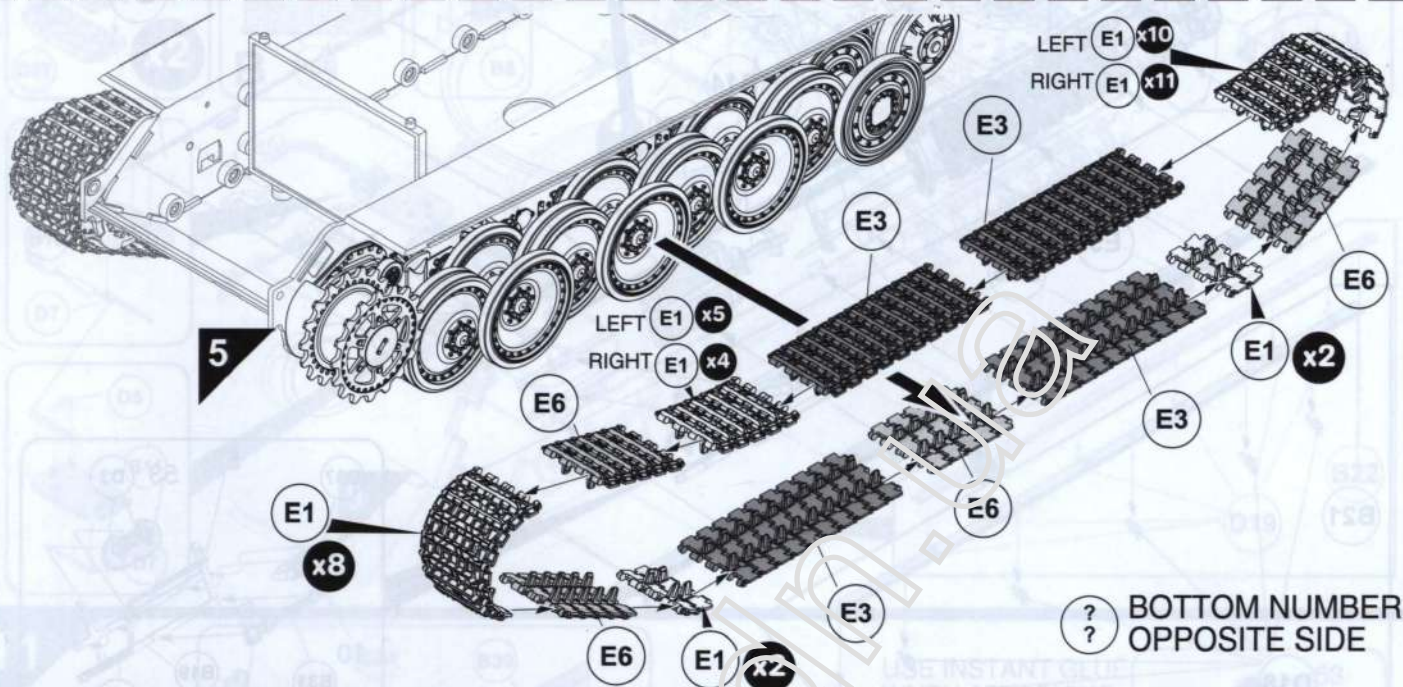
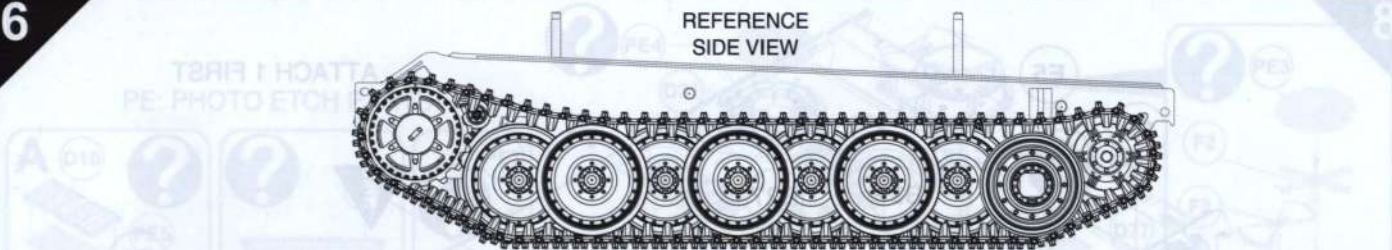

7

START ASSEMBLY WITH NUMBER 1

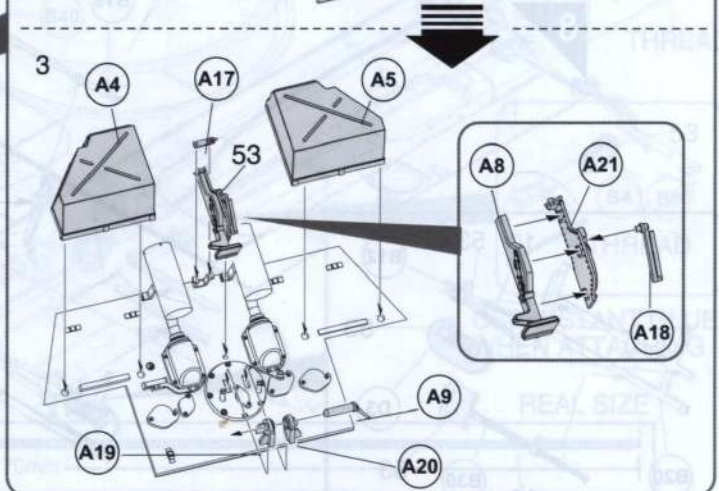
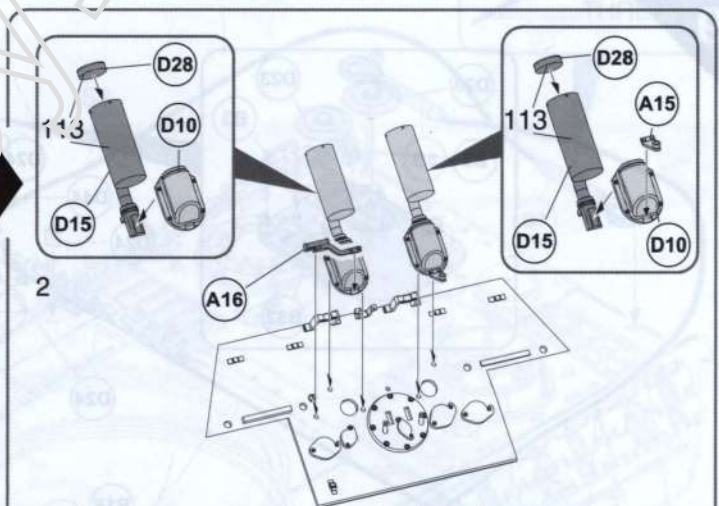
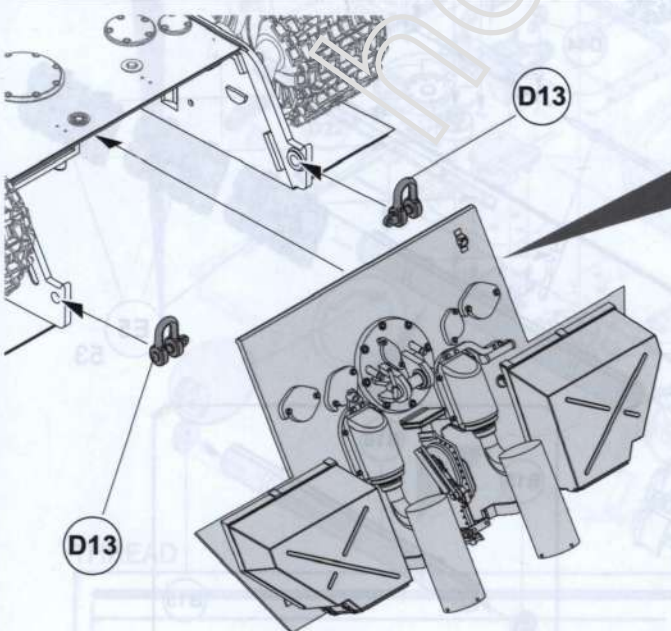
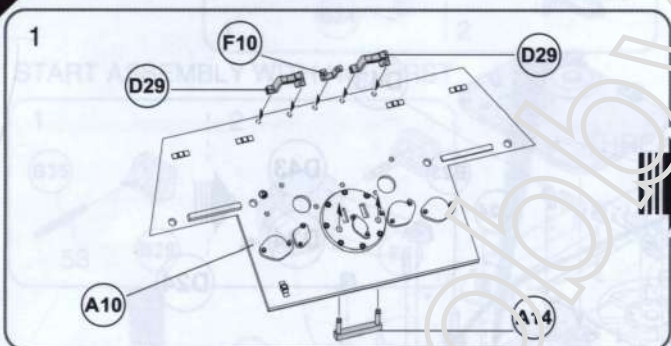

8

BOTTOM NUMBER
SIDE VIEW
OPPOSITE

ATTACH 1 FIRST

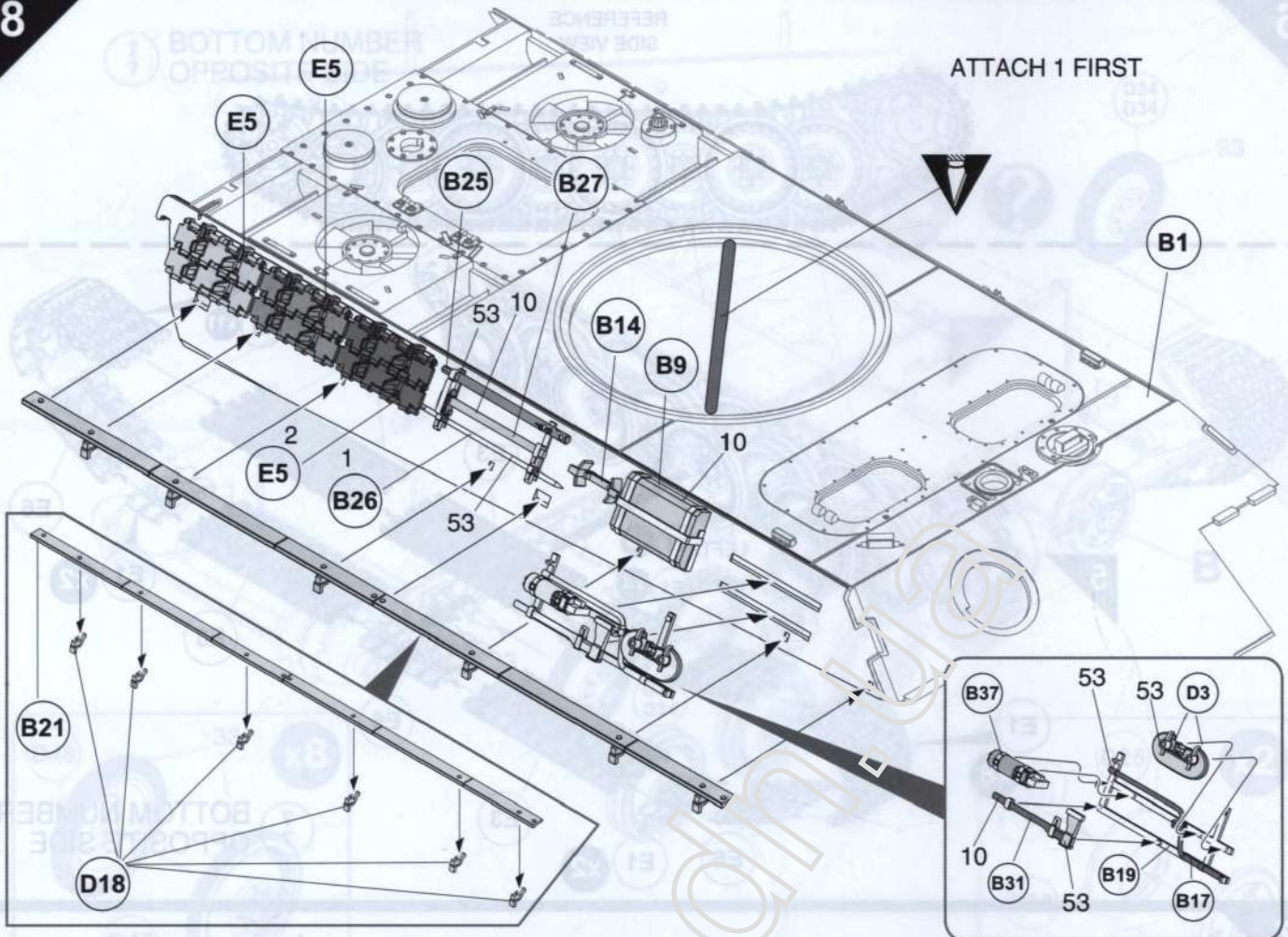

9

8

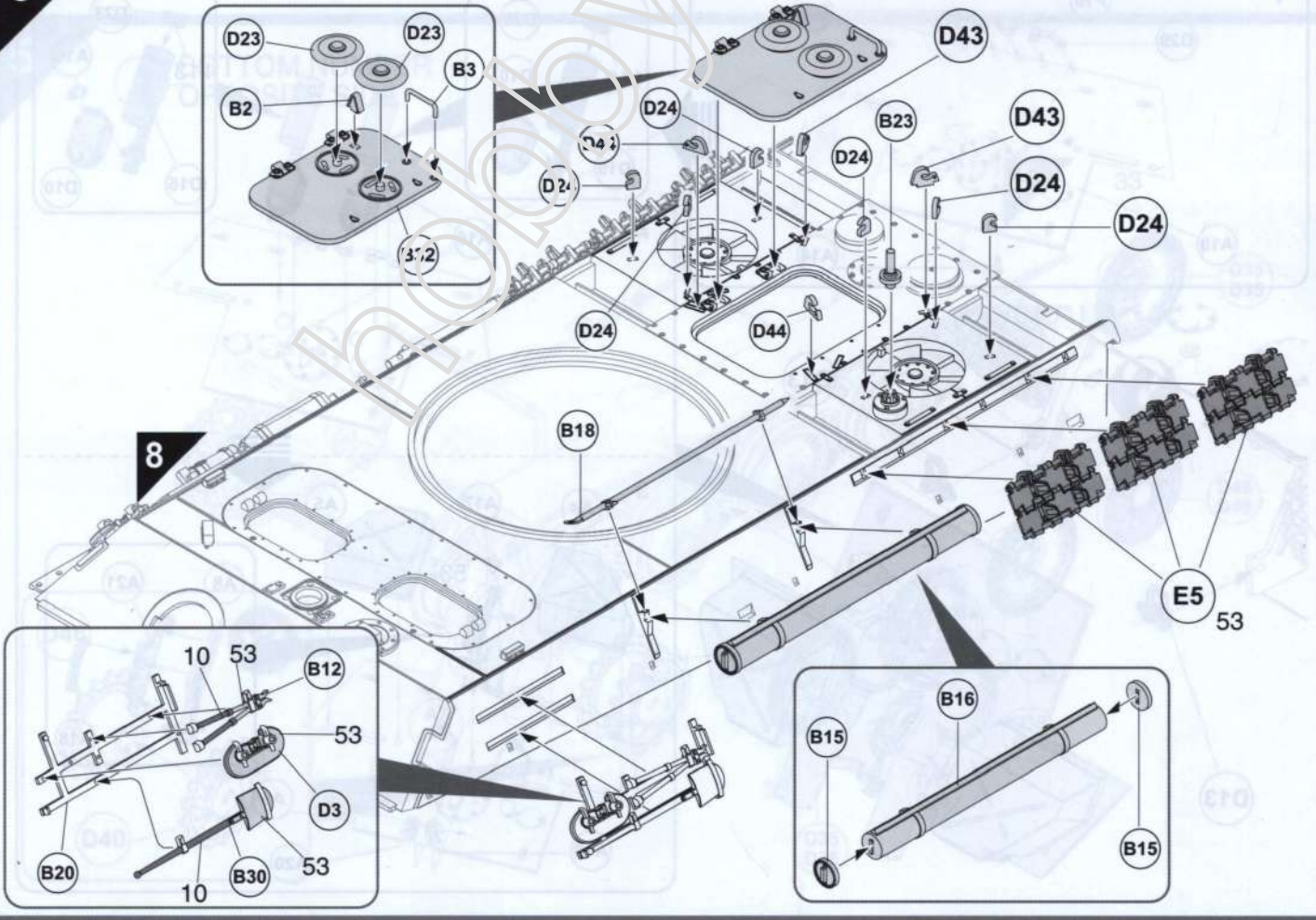

10

PE: PHOTO ETCH PARTS

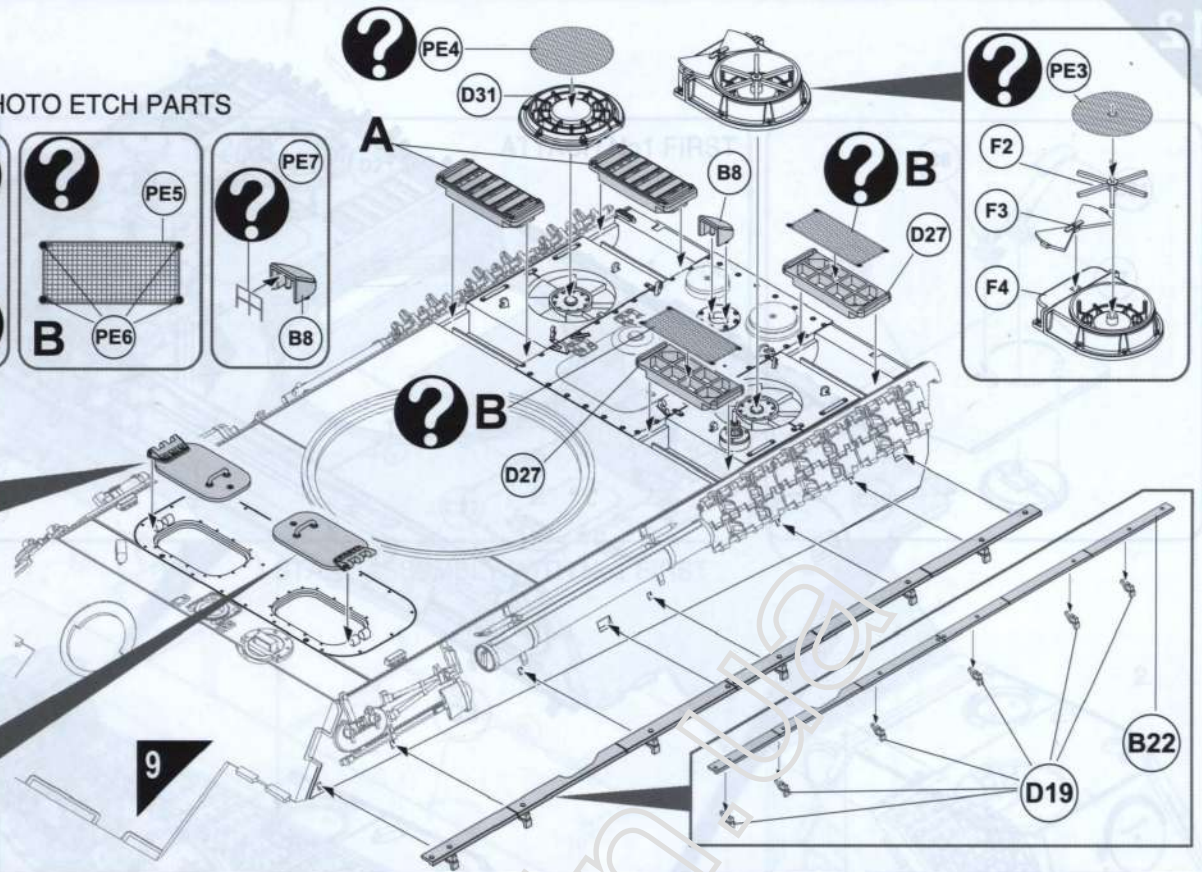
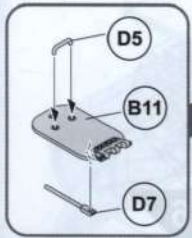
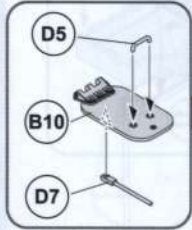
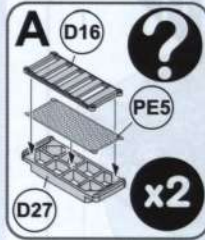

11

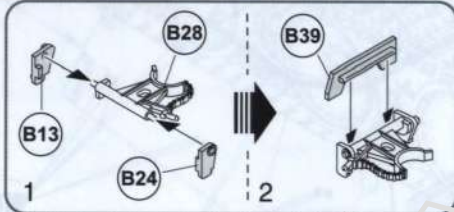

USE INSTANT GLUE WHEN ATTACHING

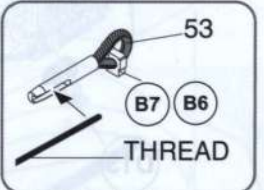

START ASSEMBLY WITH No1 FIRST

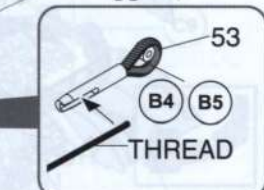
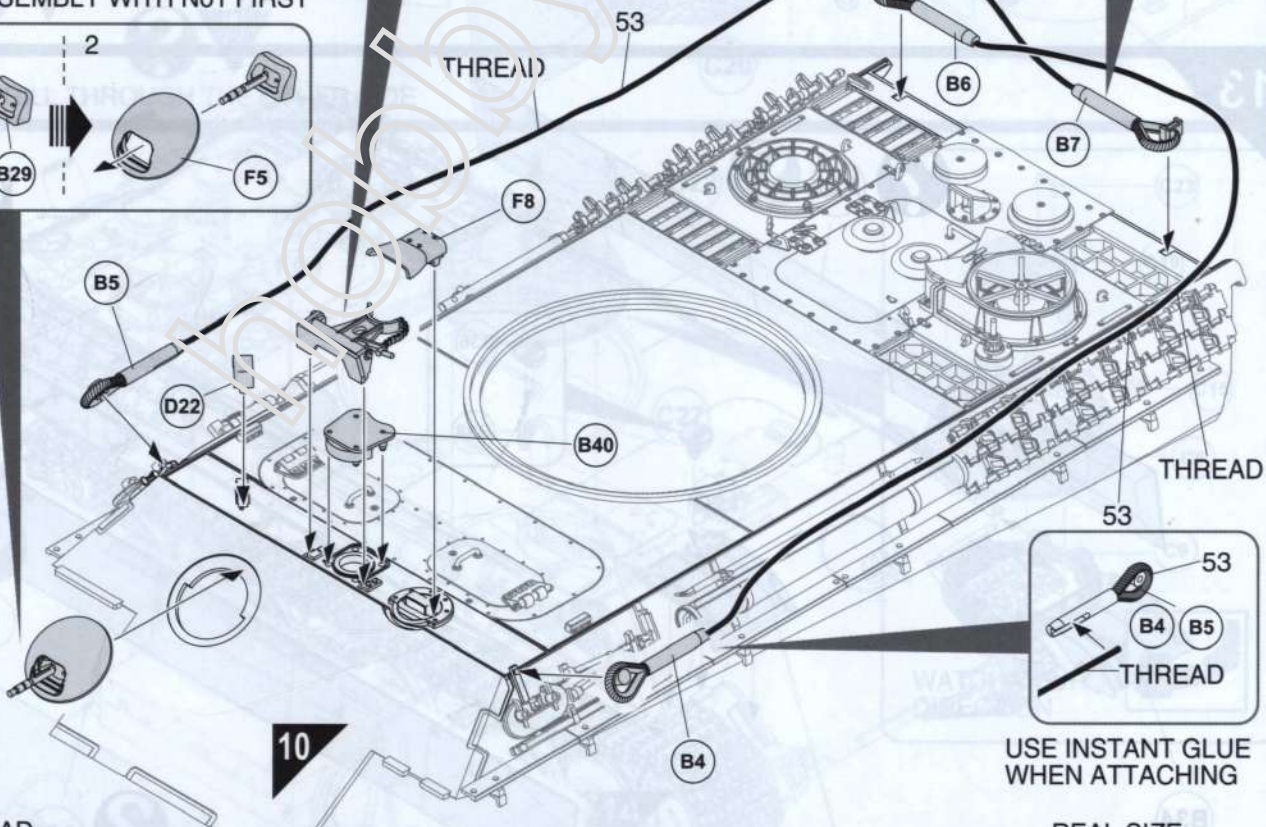
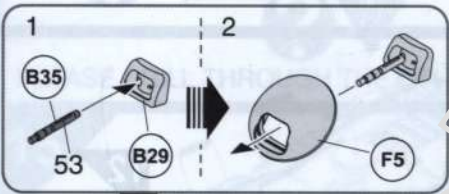

USE INSTANT GLUE WHEN ATTACHING

THREAD

REAL SIZE

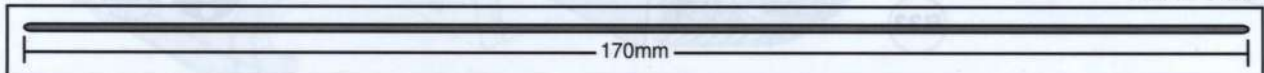

12

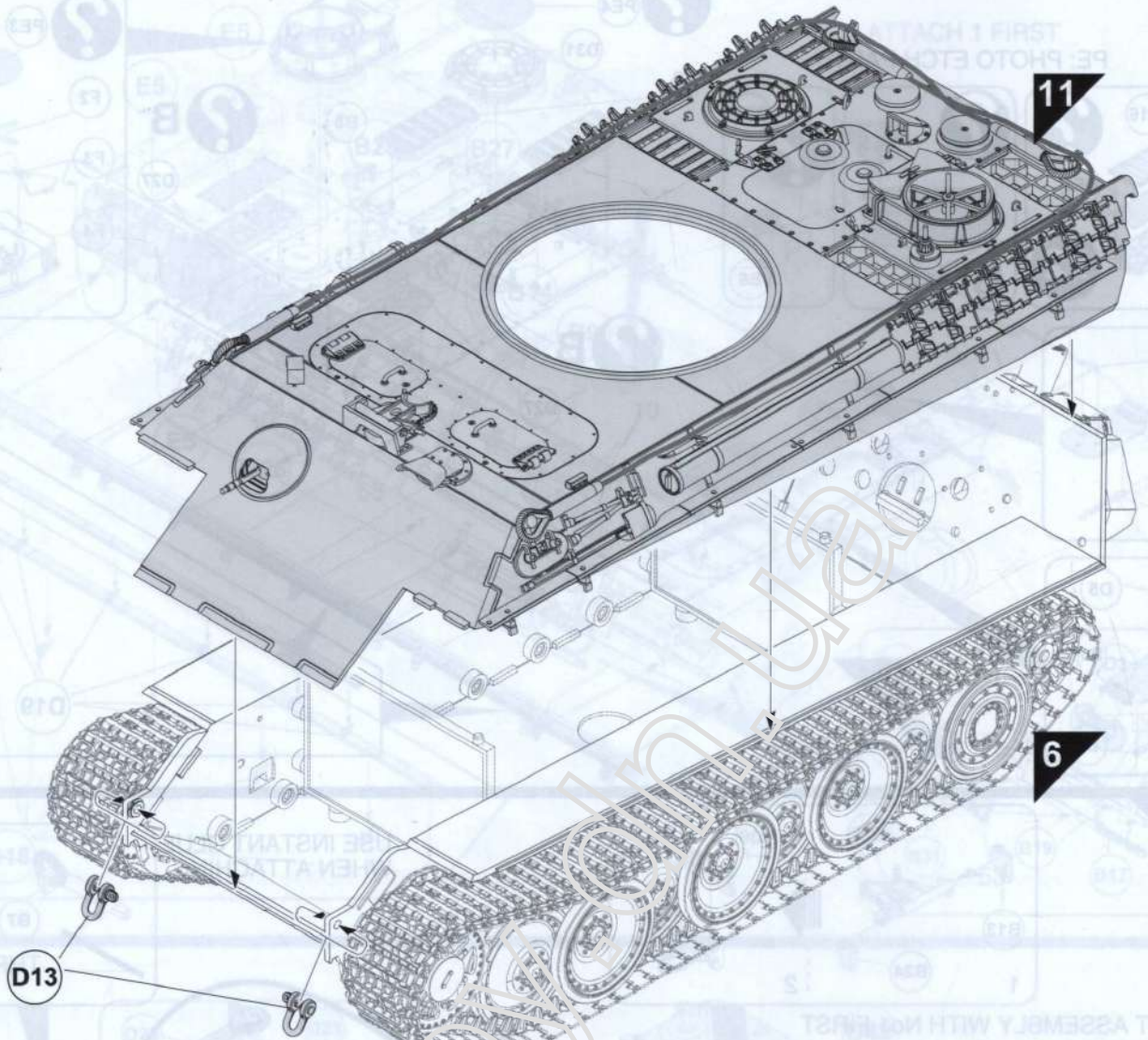

13

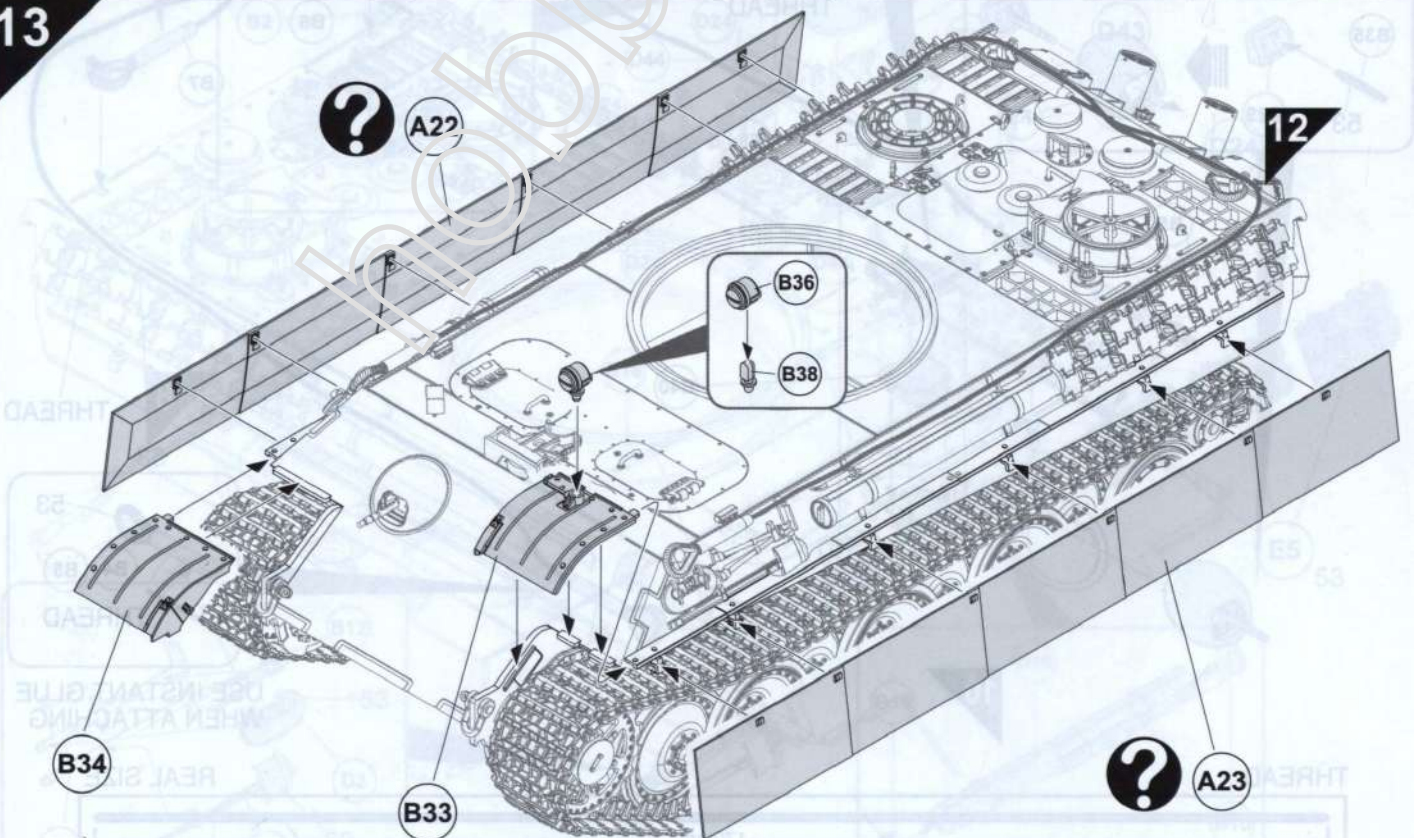

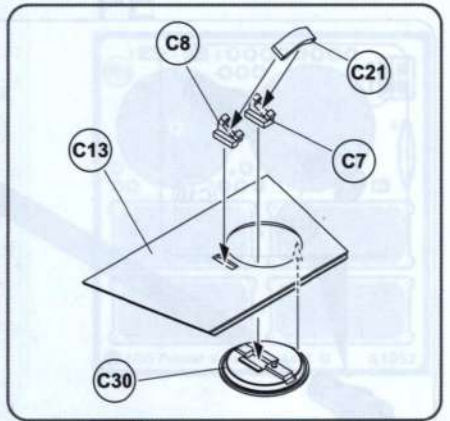
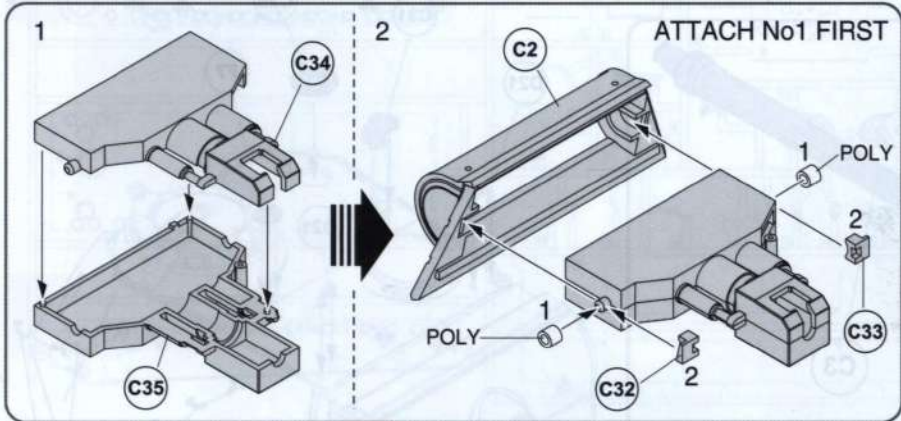

START ASSEMBLY WITH No1 FIRST

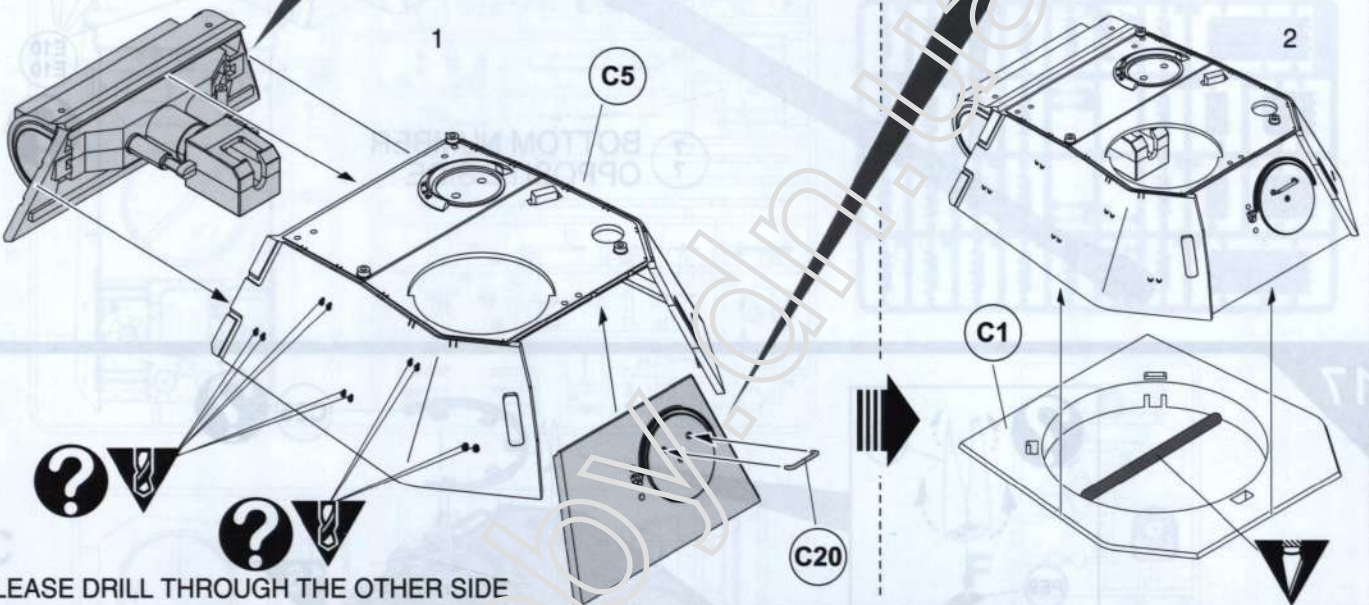

PLEASE DRILL THROUGH THE OTHER SIDE

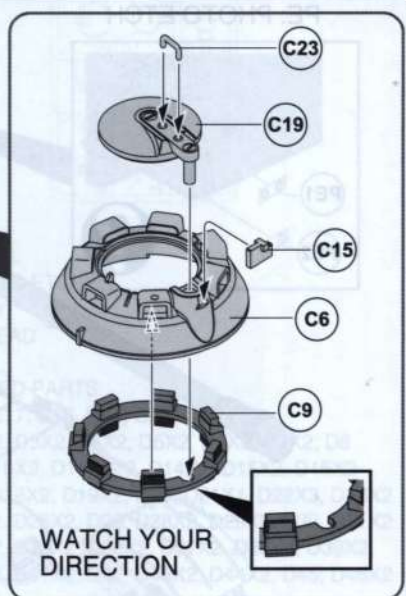
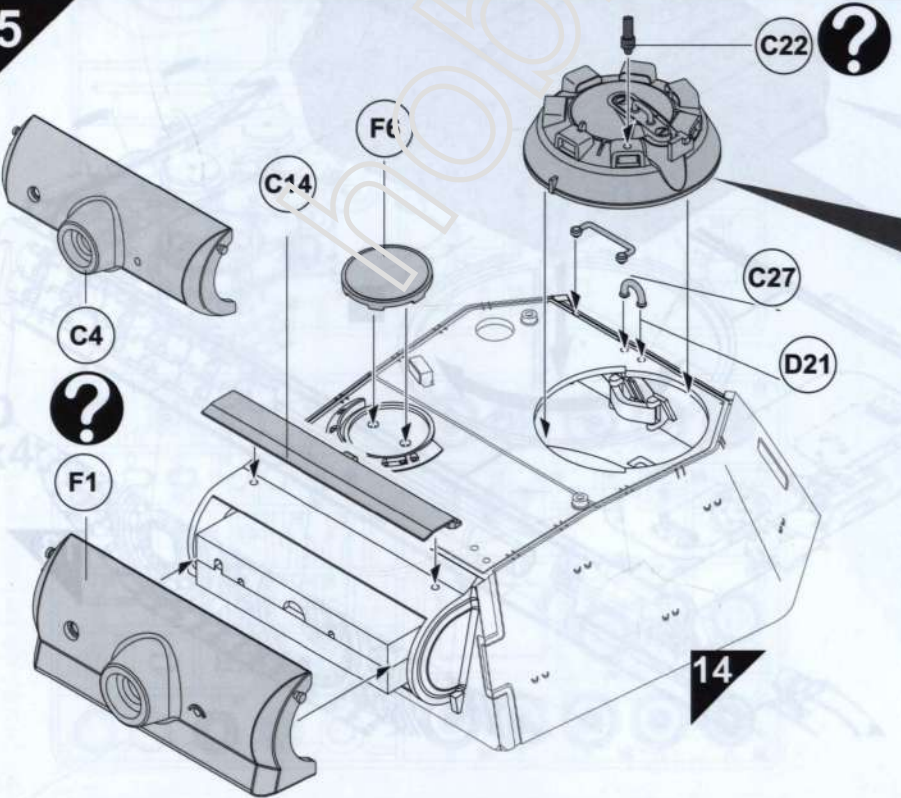

16

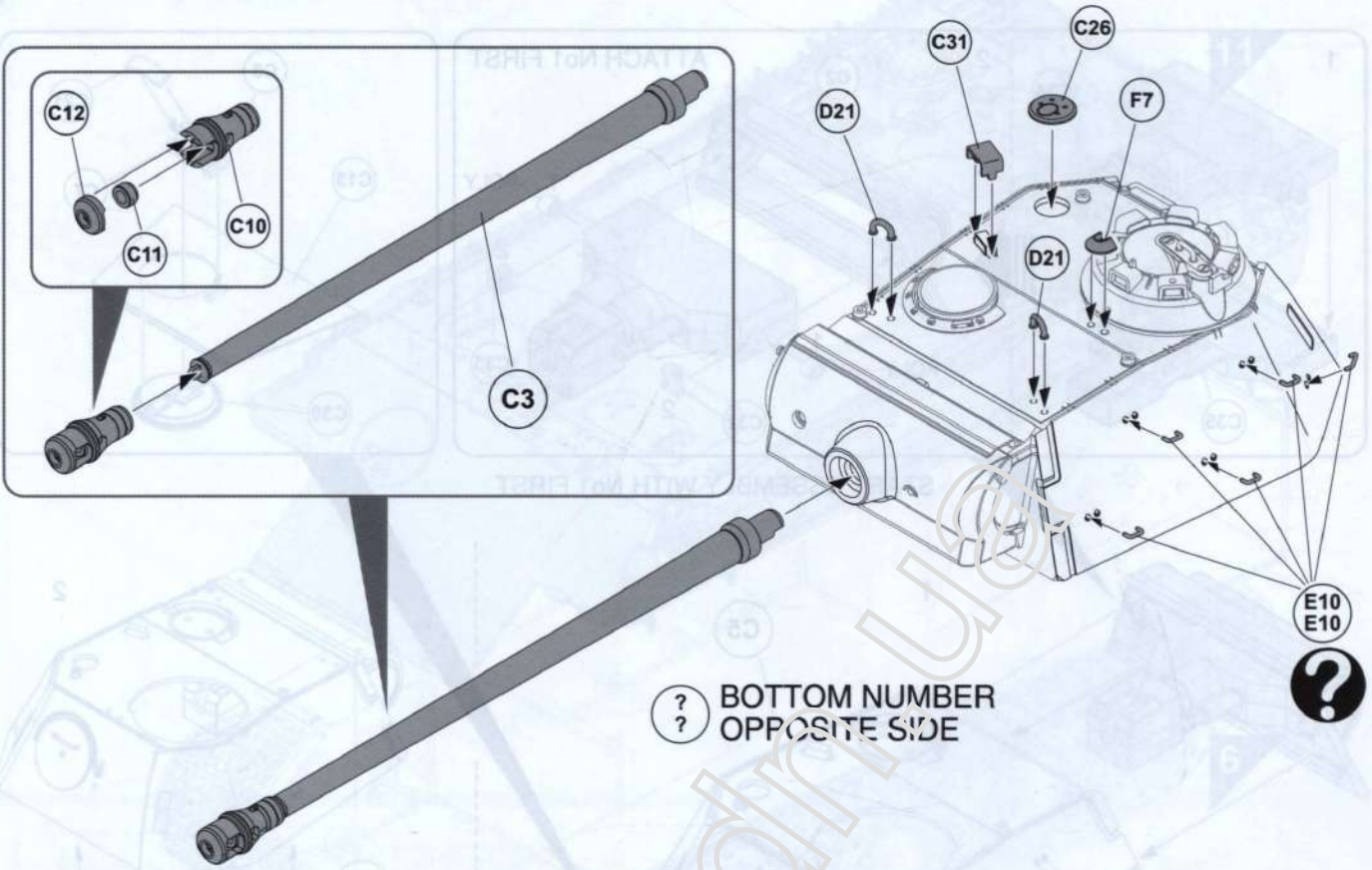

17

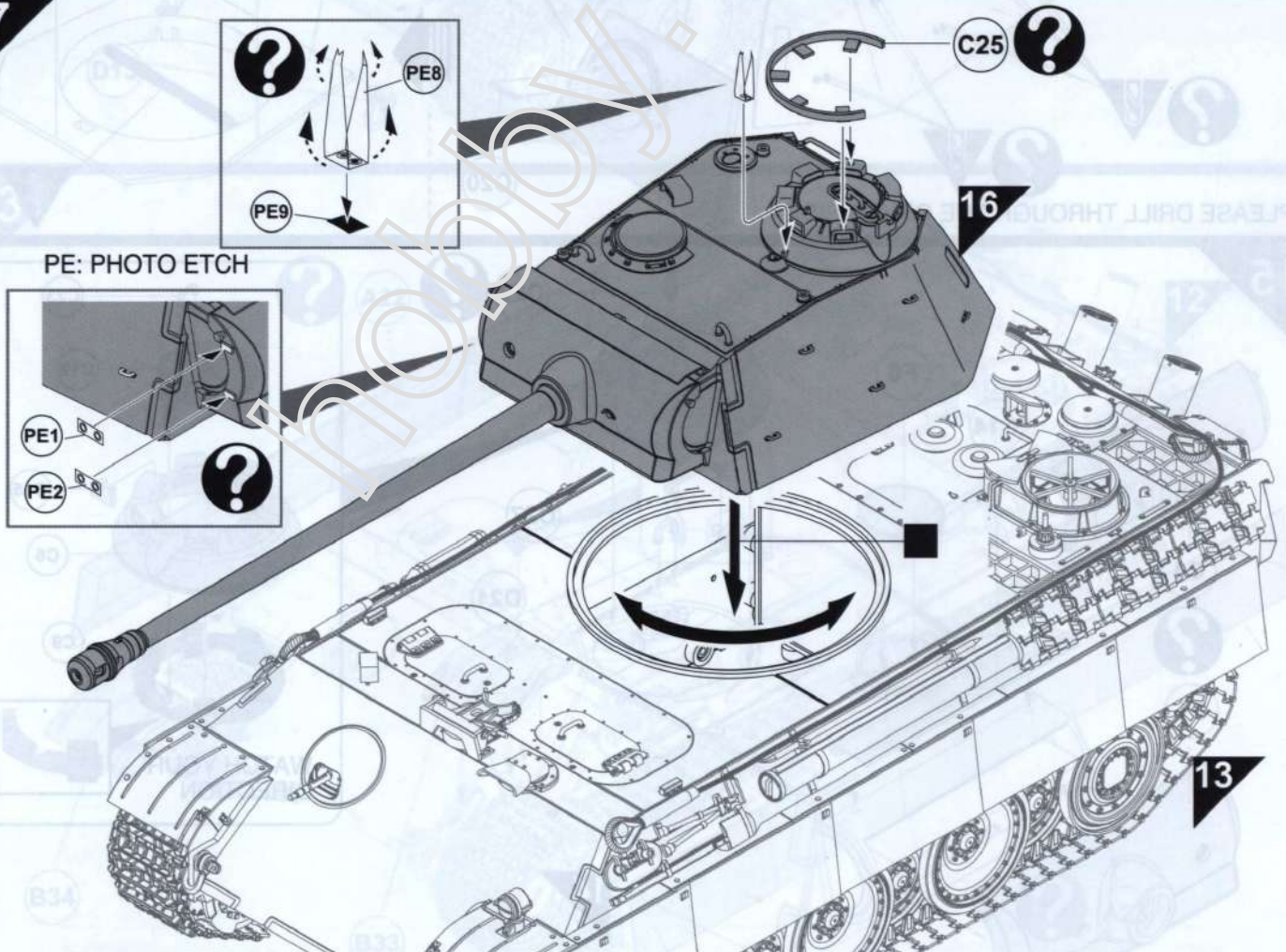

PARTS LOCATION DIAGRAM

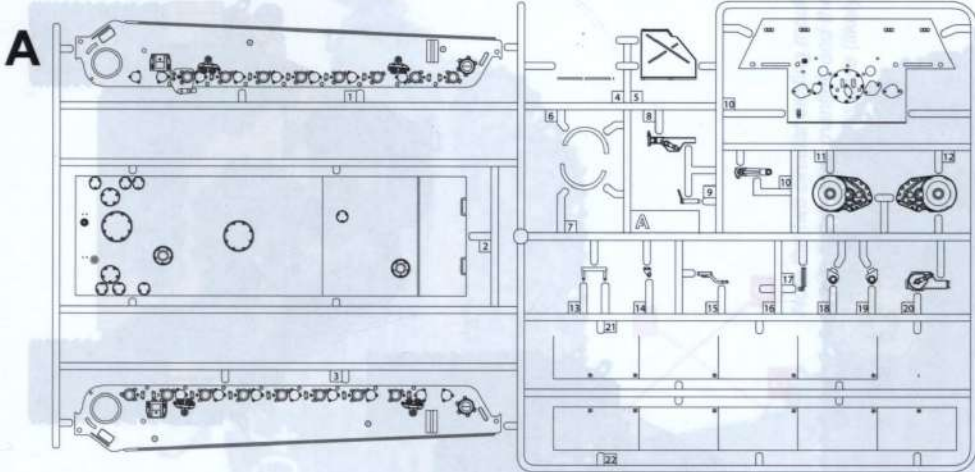

PE

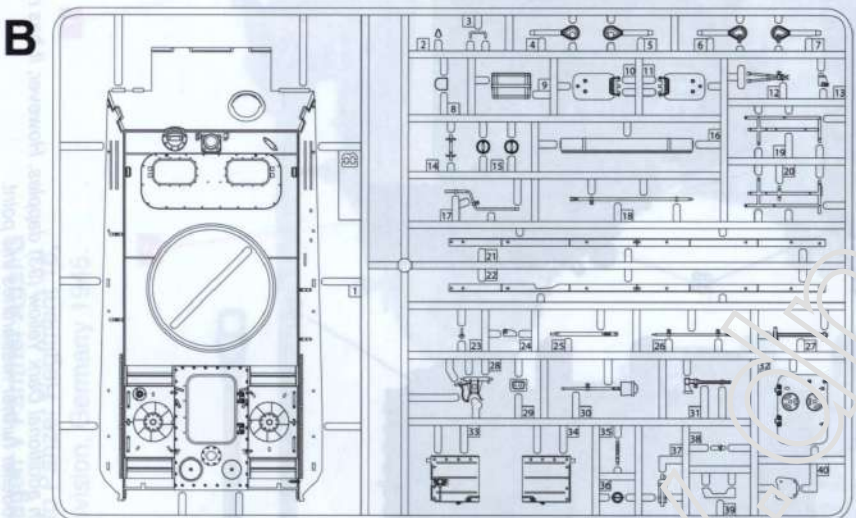

E
x4

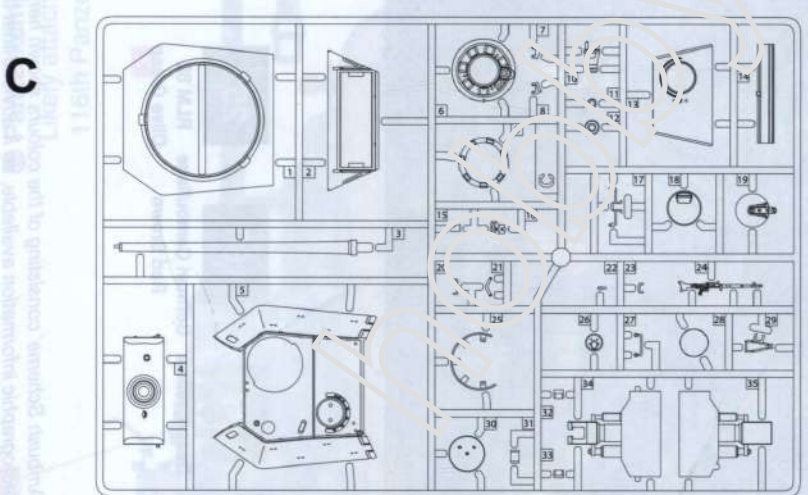
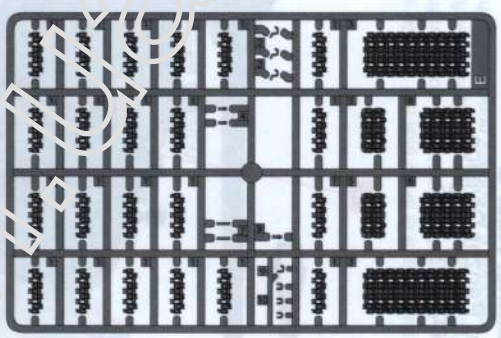

F

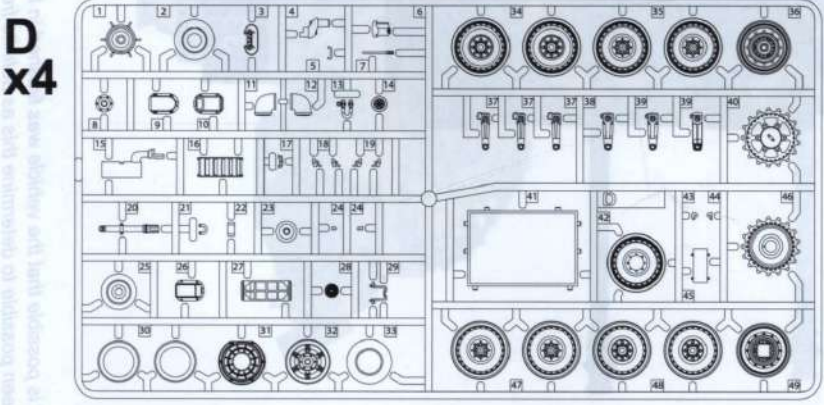
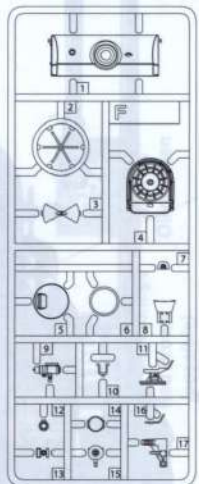

- DECAL
- PHOTO ETCHED
- POLY
- THREAD

UNUSED PARTS

- C16, C17, C18, C24, C28, C29
- D1, D2, D3X2, D4X2, D5X2, D6X2, D7X2, D8
- D9, D10X2, D11, D12, D14X2, D15X2, D16X2
- D17, D18X2, D19X2, D20, D21X1, D22X3, D23X2
- D24X2, D25X2, D26, D28X2, D29X2, D30, D31X2
- D32X2, D33X2, D36X2, D37X2, D38X4, D39X2,
- D40X2, D41X2, D42, D43X2, D44X2, D45, D46X2
- D49X2

E2, E4, E5X2, E7, E8, E9

F9, F11, F12, F13, F14, F15, F16, F17

● Panzerkampfwagen V Panther Ausf G
 Reportedly attached to the 2nd Panzer Division,
 Cleryaux, Luxembourg, February 1945.



It is possible that the vehicle was finished in the 'Ambush Scheme' consisting of the colours shown here with additional Dark Yellow (93) dapples. However, it has not been possible to determine this as definite from photographic information available, so it is advised that the modeller further researches this point.

④ Panzerkampfwagen V Panther Ausf G
Likely attached to Panzer Regiment 16,
116th Panzer Division, Germany 1945.

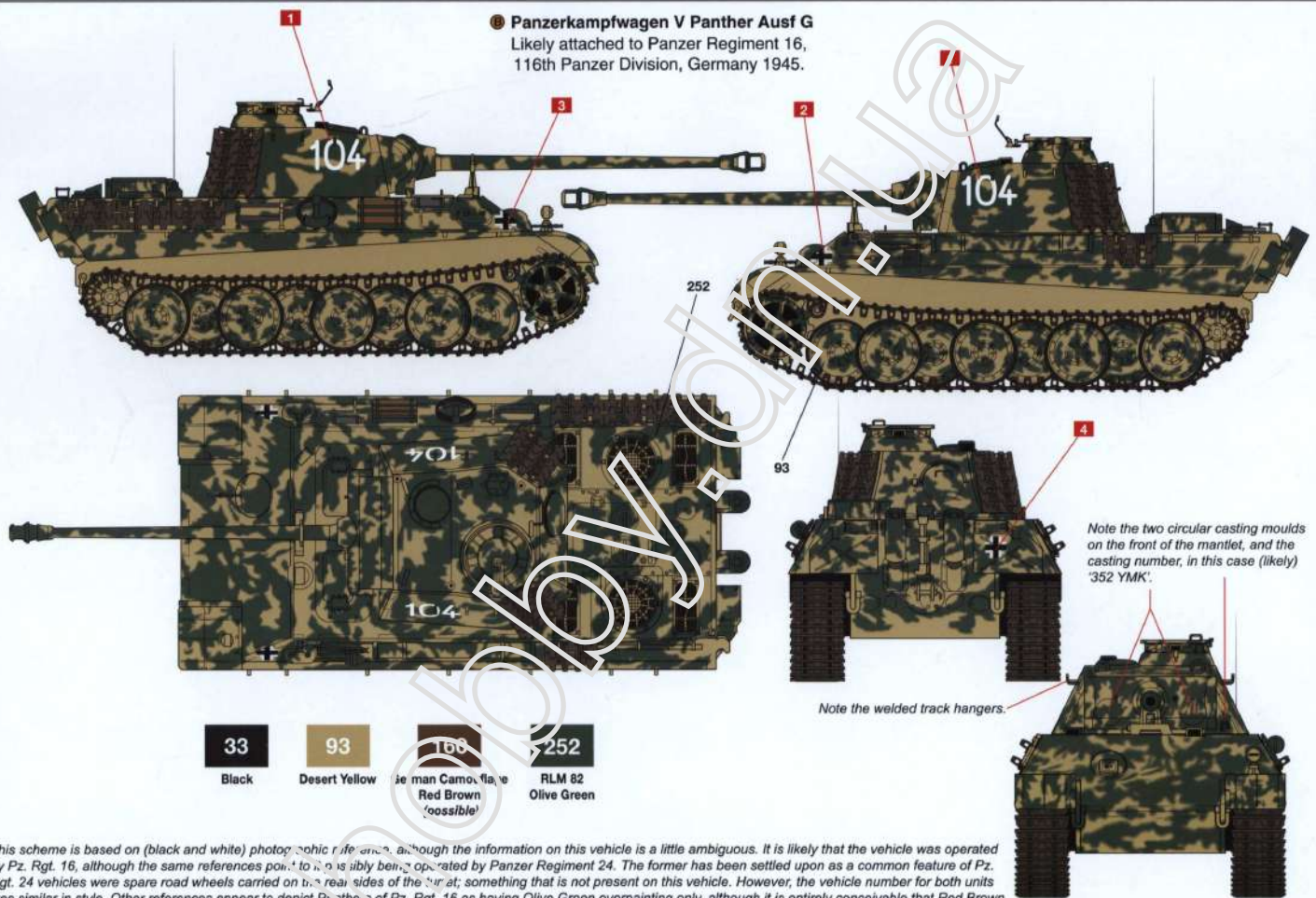

Note the two circular casting moulds on the front of the mantlet, and the casting number, in this case (likely) '352 YMK'.

Note the welded track hangers.

- 33
Black
- 93
Desert Yellow
- 100
German Camouflage
Red Brown
(possible)
- 252
RLM 82
Olive Green

This scheme is based on (black and white) photographic references, although the information on this vehicle is a little ambiguous. It is likely that the vehicle was operated by Pz. Rgt. 16, although the same references point to it possibly being operated by Panzer Regiment 24. The former has been settled upon as a common feature of Pz. Rgt. 24 vehicles were spare road wheels carried on the rear sides of the turret; something that is not present on this vehicle. However, the vehicle number for both units was similar in style. Other references appear to depict Panthers of Pz. Rgt. 16 as having Olive Green overpainting only, although it is entirely conceivable that Red Brown was also employed. The scheme is based on these photographs where possible.