



Messerschmitt BF.109 B-1

The Messerschmitt Bf 109's versatility and time in service with both the German Luftwaffe and other foreign air forces, numerous variants were produced over the eight years of service with the Luftwaffe and even more were produced by its foreign service.

The Bf 109B entered production during the Autumn of 1936. By then? BFW had been reorganized into the Messerschmitt A.G., and the first operational variant entered service in April 1937. It was planned that the type should enter service with the 2/132 "RICHTHOFEN" in Germany.

Production model Bf 109B began to appear in Spain. The Bf 109B scored its first combat victory in 06.04.1937, when Oblt G.Lutzov shot down an I - 15.

The Bf 109B was the first version of this famous fighter to enter mass production.

References:

- Messerschmitt Bf 109 A-D models, KAGERO, M.Lukasik
- Messerschmitt Bf 109, WARPAINT Special N 2,
- Bf 109 part 1, SAM Datafile N 09,
- Me 109 A bis Me 109 E, Aviatic Verlag, 1997,
- Messerschmitt Me-109, W.Ridinger & W Schick,
- Cockpits DSeutscher Flugzeuge 1911-70, P.W. Cohauz,
- Luftwaffe Camouflage and Markings 1933-1945 vol.1, K.A. Merrick,
- Luftwaffe Colours 1935-1945, Hikoku Publ., M.Ullmann,
- Luftwaffe Colours vol.1, sec.1 JAGDWAFFE, E.Mombeck,
- Flugzeug Classic Extr / MESSERSCHMITT Bf 109 teil 1,
- Flugzeug Classic 1/2001, 3
- Aero Journal N 18.

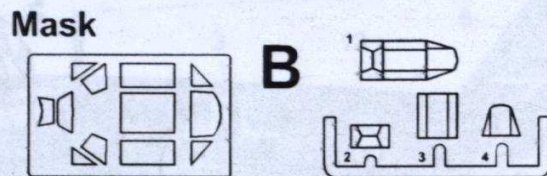
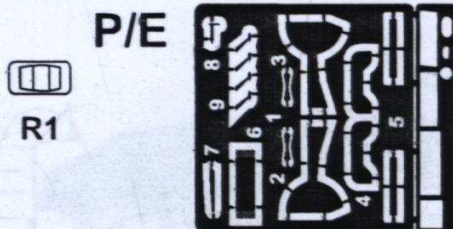
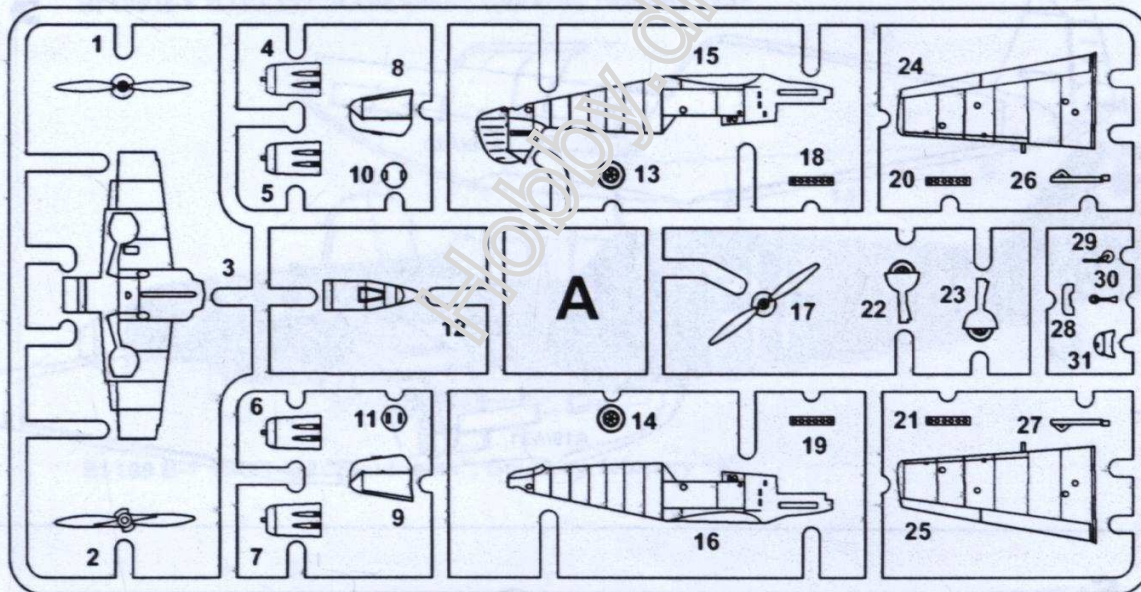

THE CONDITIONAL DENOTATION УСЛОВНЫЕ ОБОЗНАЧЕНИЯ

- BE CAREFUL / ОСТОРОЖНО
- DON'T CEMENT / НЕ КЛЕИТЬ
- REMOVE / РЕЗАТЬ
- SYMMETRICAL / СИММЕТРИЧНО
- MAKE TWO / УДВОИТЬ
- OPTIONAL / НЕОБЯЗАТЕЛЬНО
- BEND / СОГНУТЬ
- OPEN WHOLE / СВЕРЛИТЬ
- CEMENT / КЛЕИТЬ
- VARIANTS / ВЫБОР ВАРИАНТА

ASSEMBLY MANUAL

1

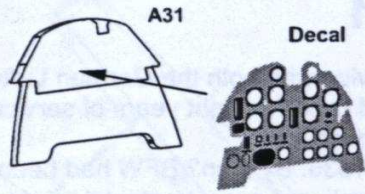

2

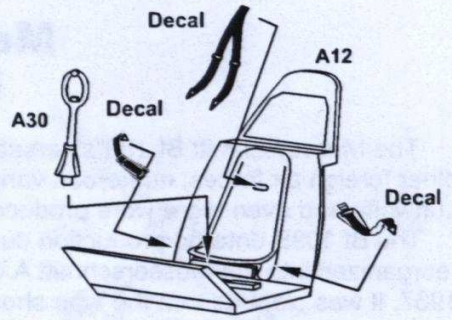

3

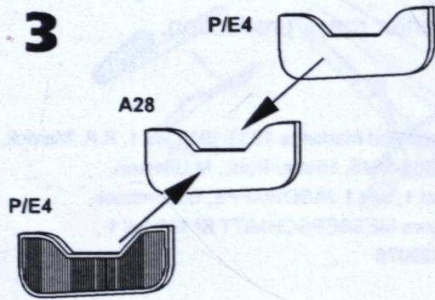

4

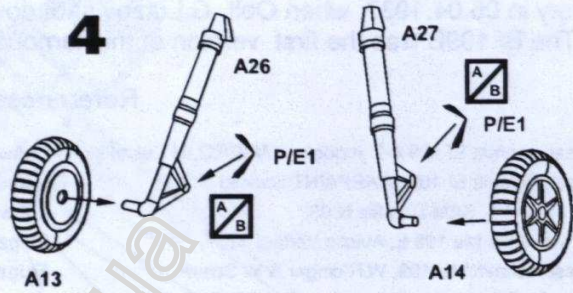

5

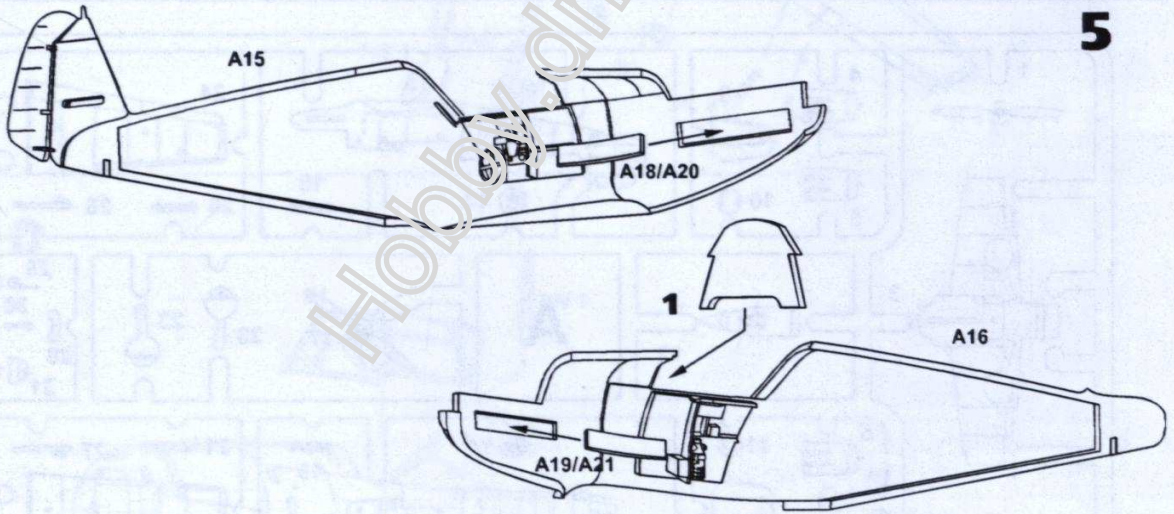

6

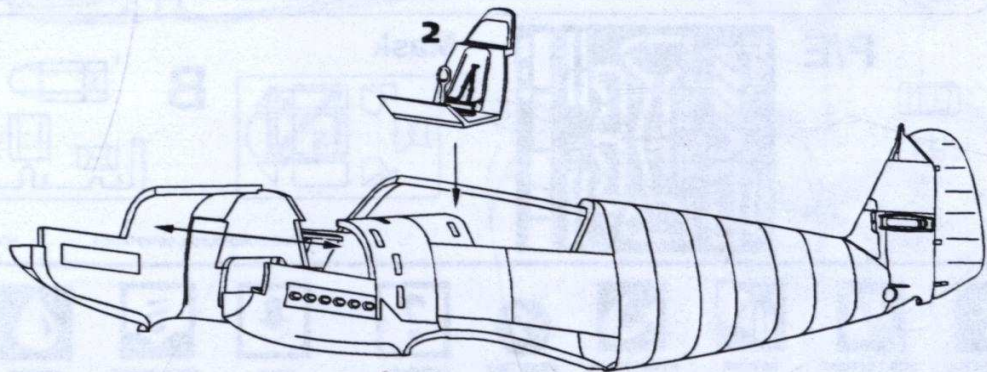

7

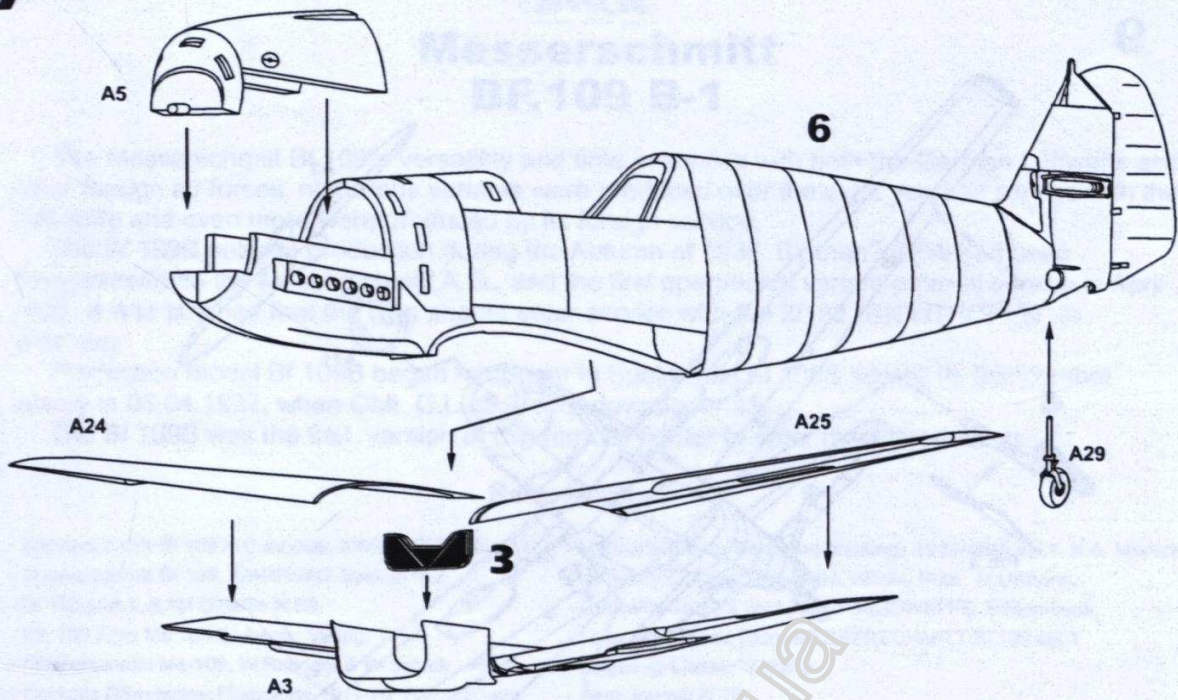

8

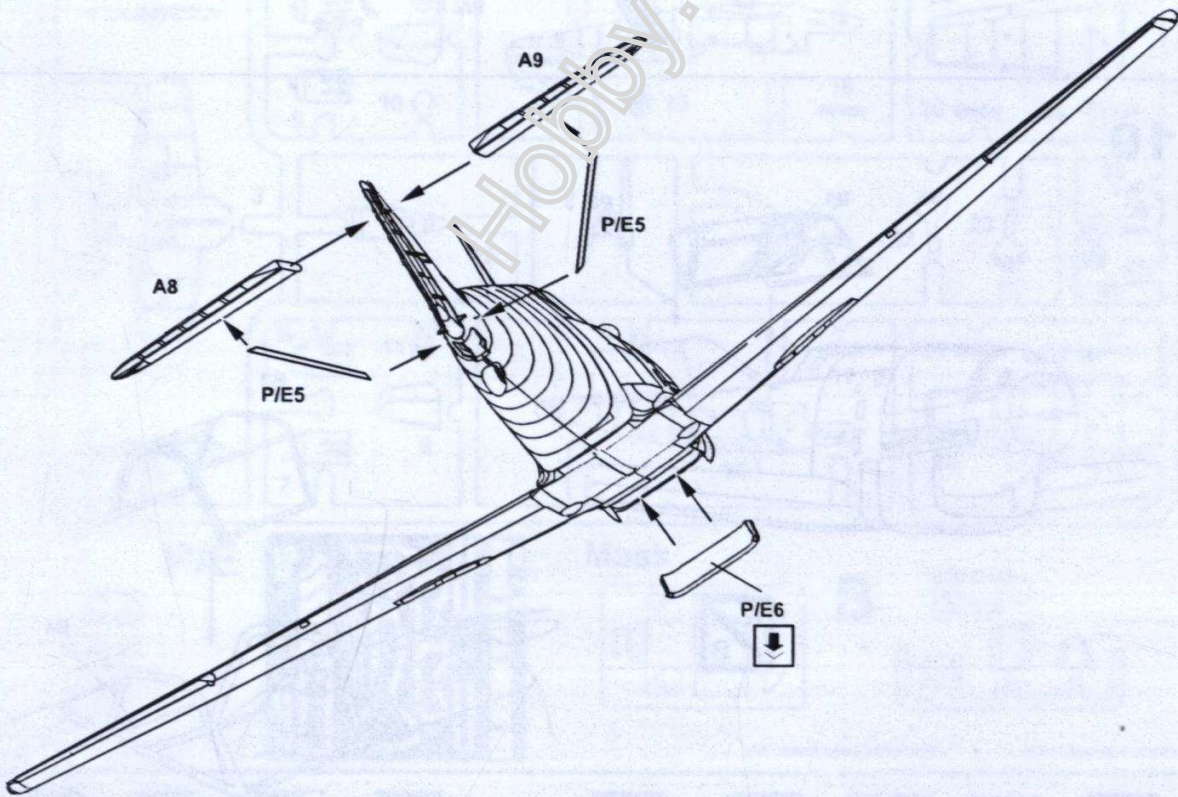

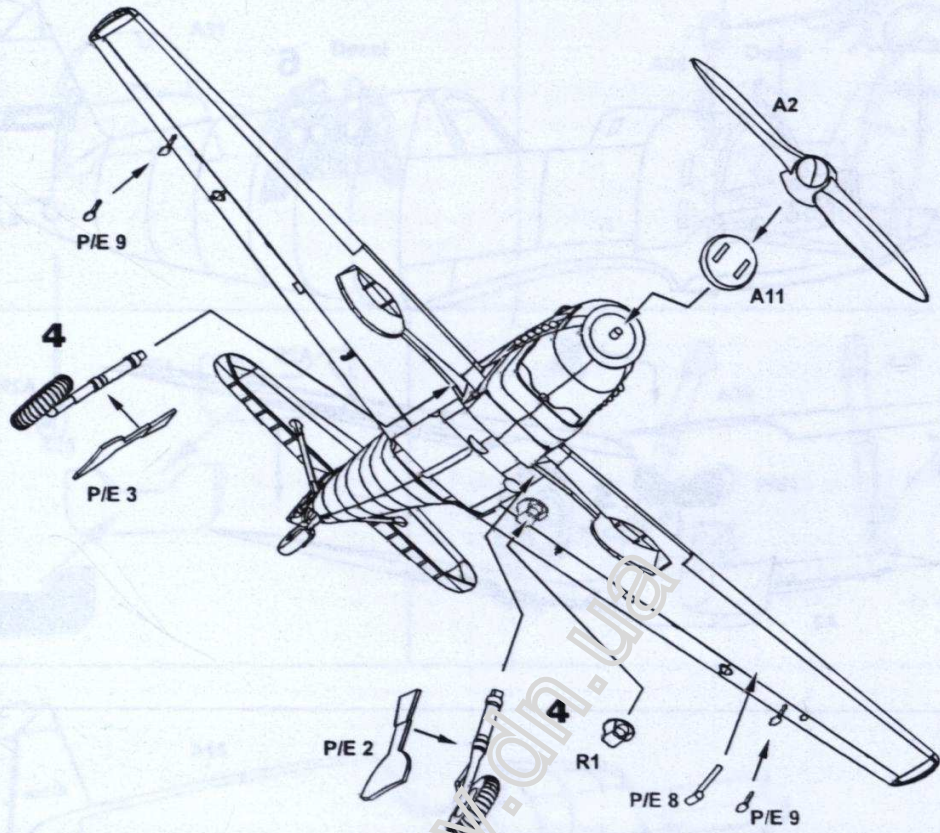

9

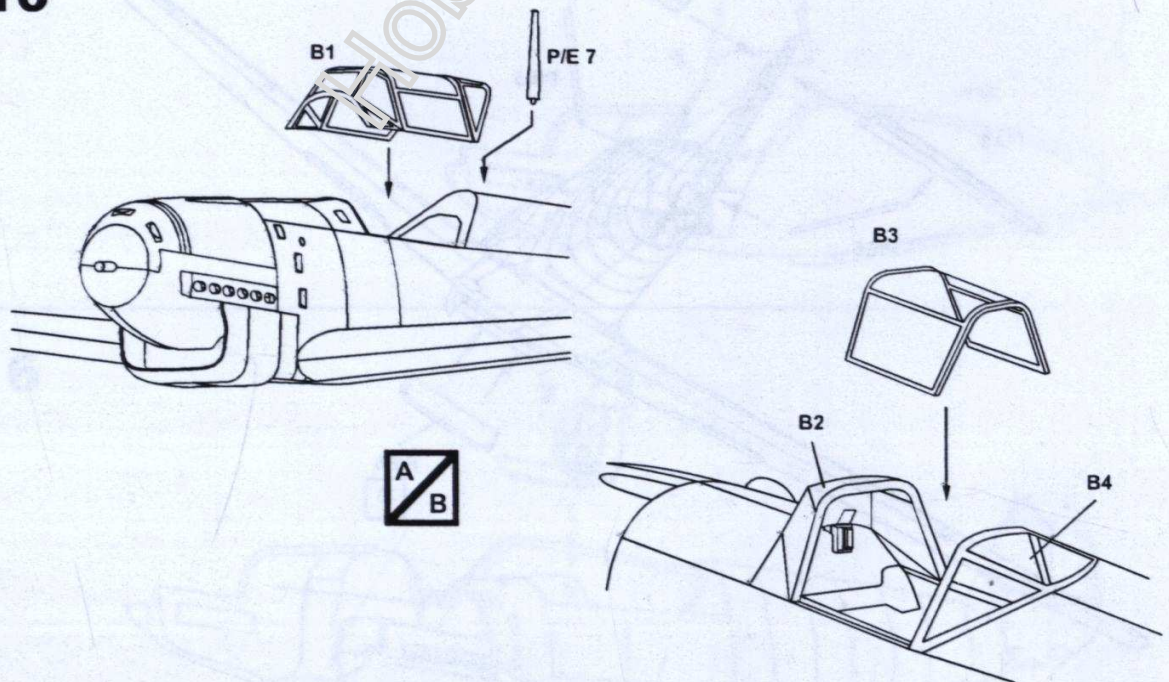

10

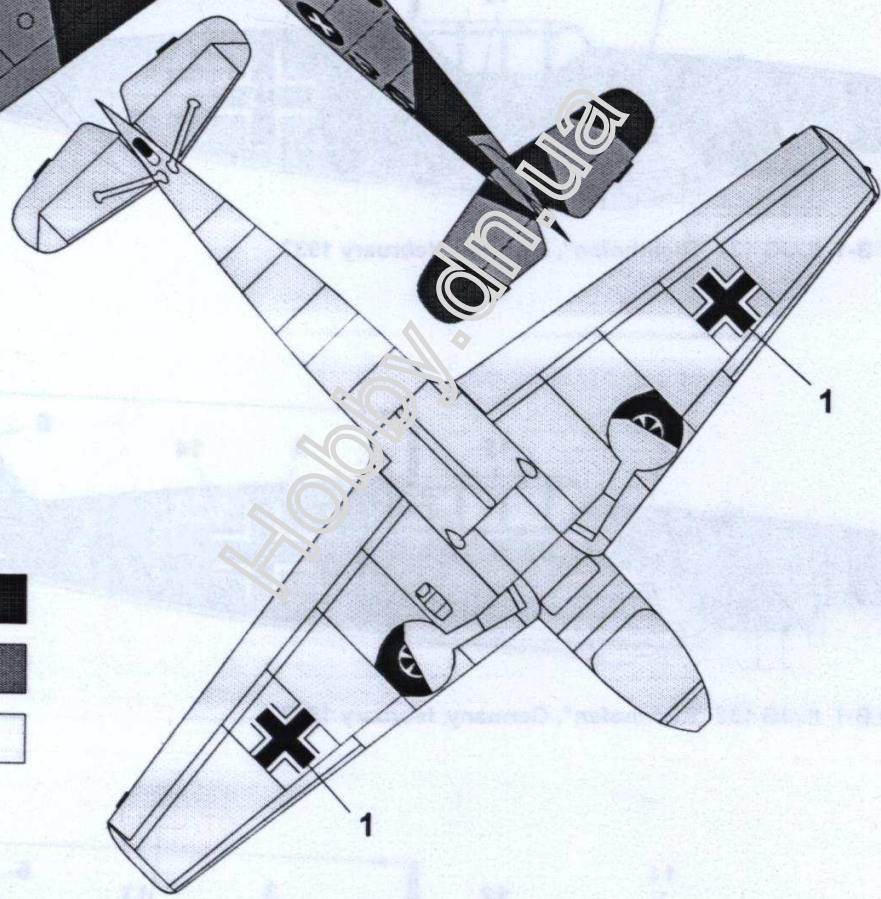
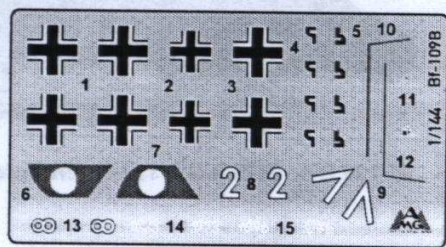
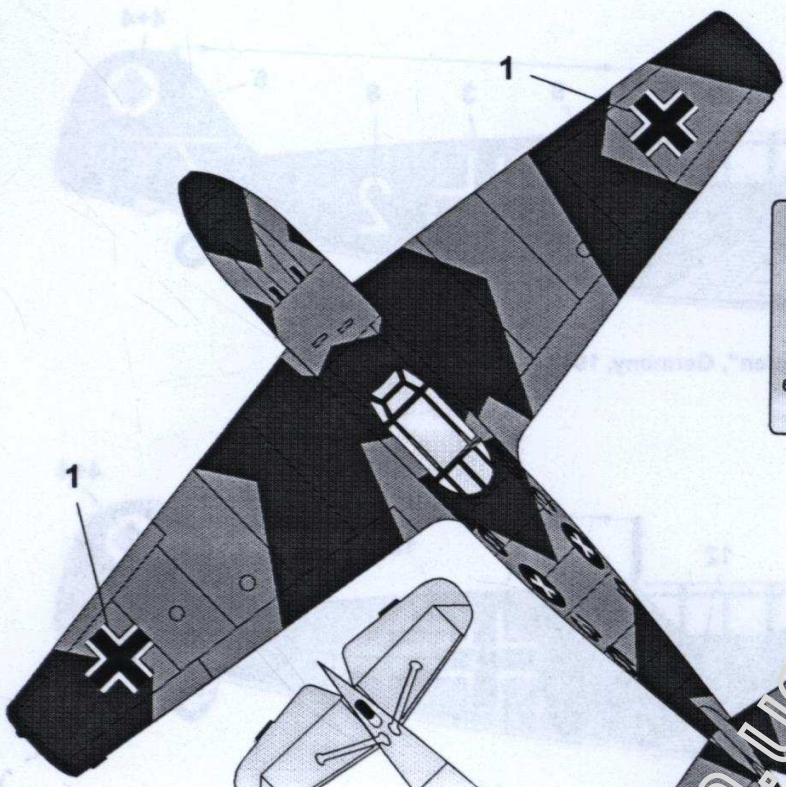

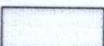

- RLM 70 
- RLM 71 
- RLM 62 

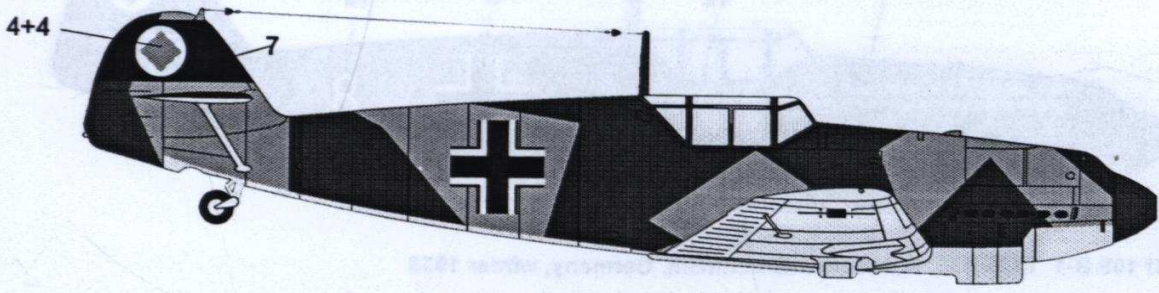

PAINT MANUAL

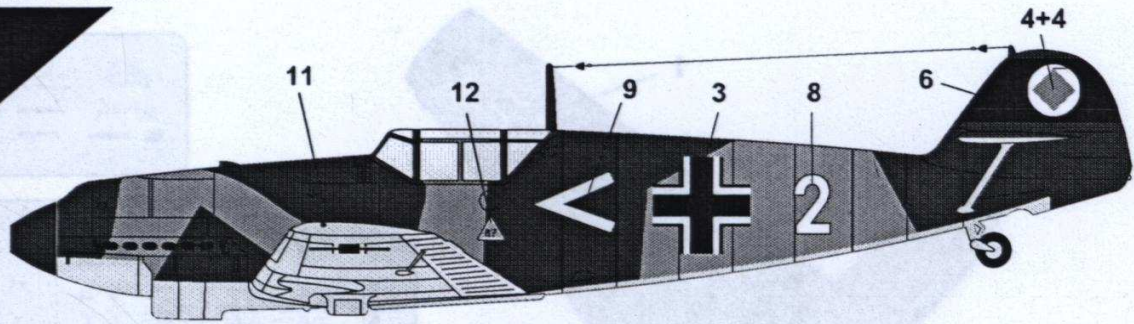

Bf 109 B-1 Stab II./JG 132 "Richthofen", Germany, 1938

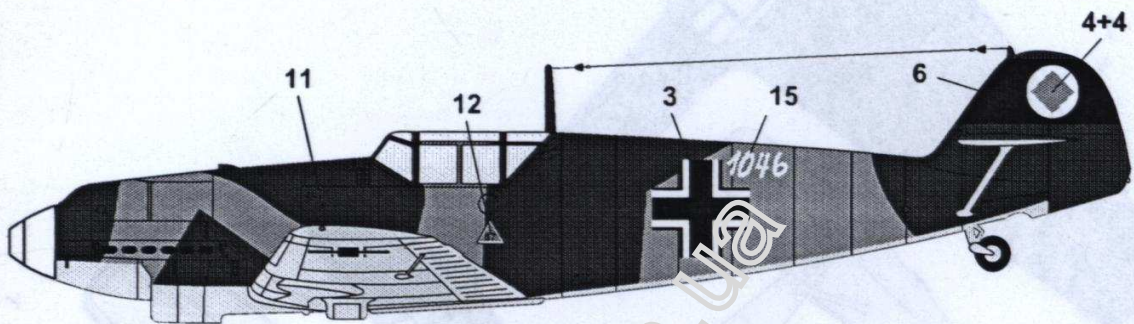

Bf 109 B-1 II./JG 132 "Richthofen", Germany, february 1937

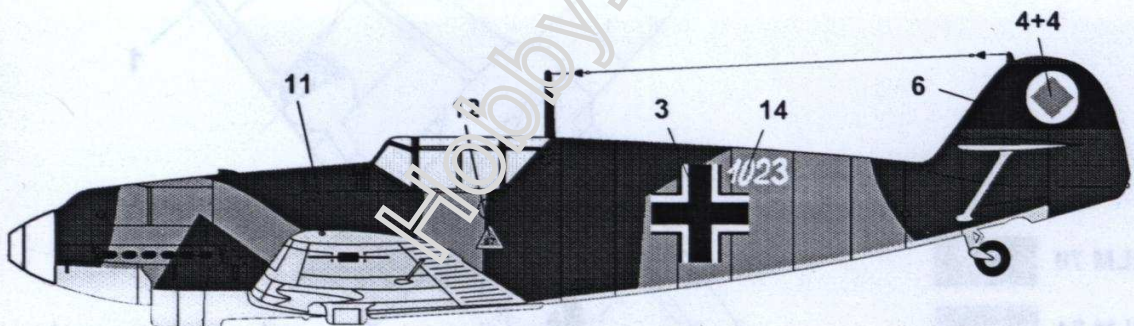

Bf 109 B-1 II./JG 132 "Richthofen", Germany, february 1937

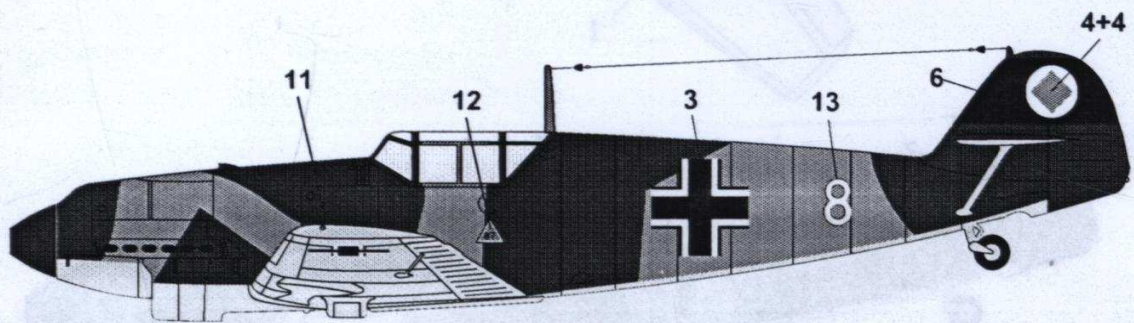

Bf 109 B-1 1./JG 133, Wiesbaden-Erbenheim, Germany, winter 1938