



Polikarpov I-15bis Spanish (Nationalists)

№ 48323

The Polikarpov I-15 bis was the second in the series of biplanes that began with the I-15 and ended with the I-153.

Production began at Zavod 21 in Moscow in the middle of 1937, but didn't reach full speed until 1938. Early aircraft used the same M-25 engine as later I-15s. This was replaced in mid -1938 by the M-25V, which improved its performance altitude. Fuel capacity was also improved during the production run. The I-15bis had a NACA cowl, replacing the narrower Townend ring used on the I-15.

A total of 2400 I-15bis were produced, starting in the autumn of 1937 and ending in 1939

The end of 1938, USSR approved the delivery of three batches of I-15bis ("Super Chato") in response to a request for assistance from the Commander-in-Chief of the Republican AF. On these 93 aircraft one batch of 31 reached Spain, and in January 1939 was formed into three squadrons of 9 aircraft.

Two were list in accidents and the remaining 29 escaped to France. Twenty of these aircraft were later returned to Spain, where they remaining in front line use until the mid 1940s, and were used for secondary duties until 1954 !

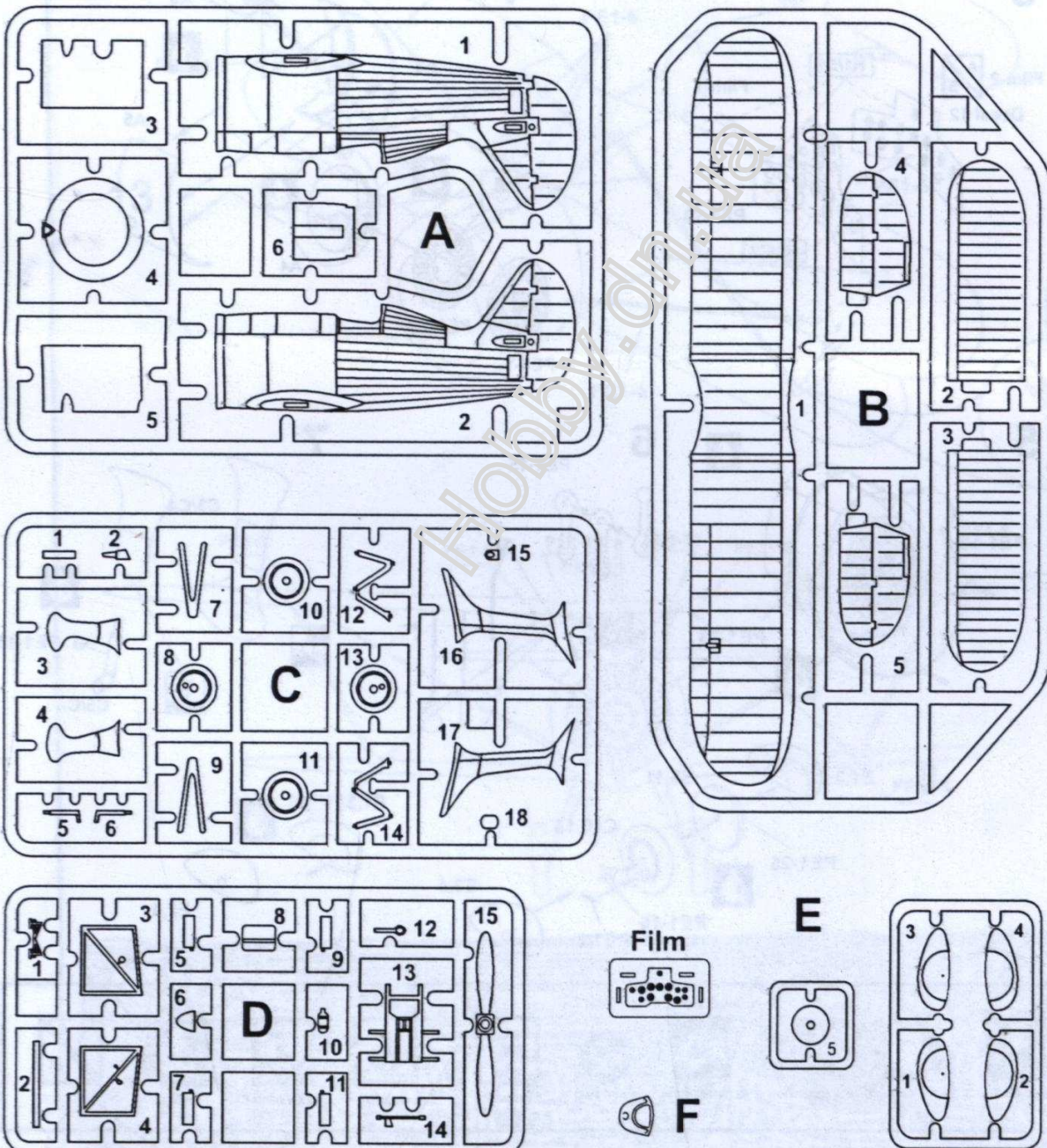

ASSEMBLY MANUAL

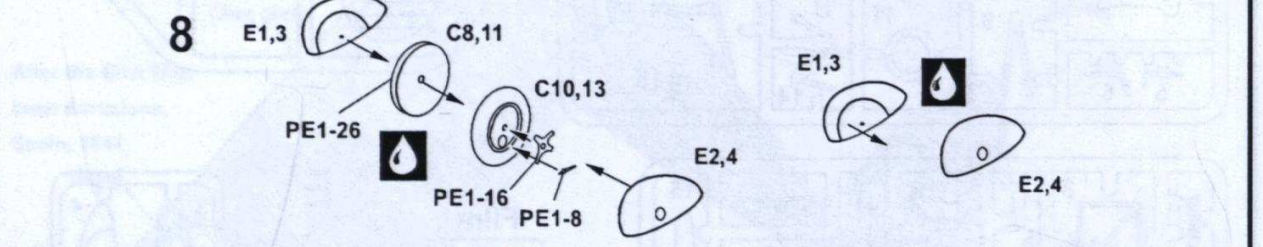
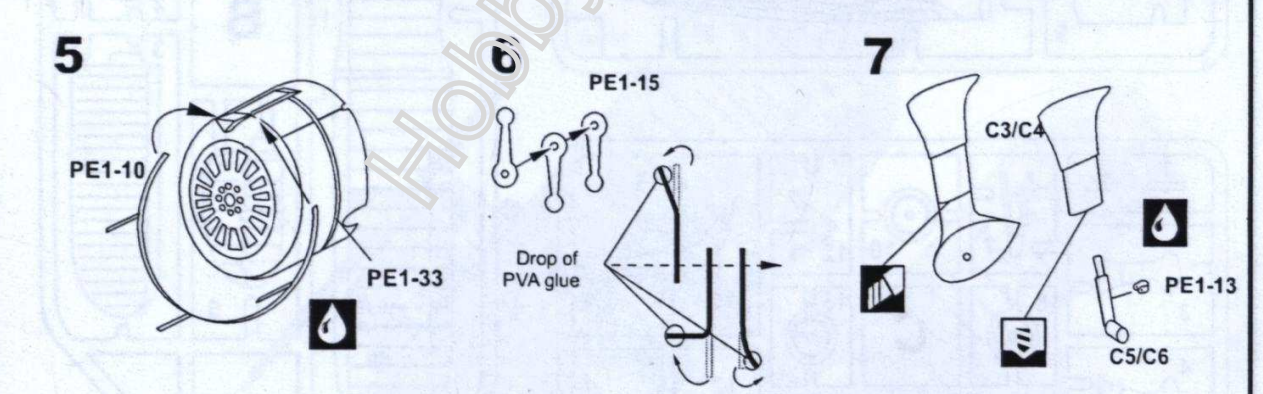
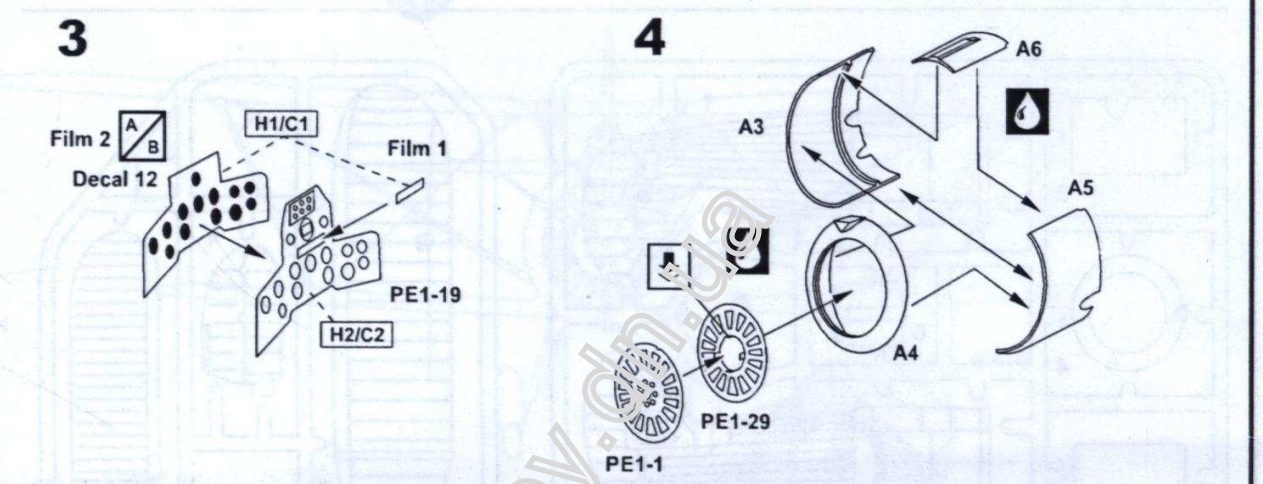
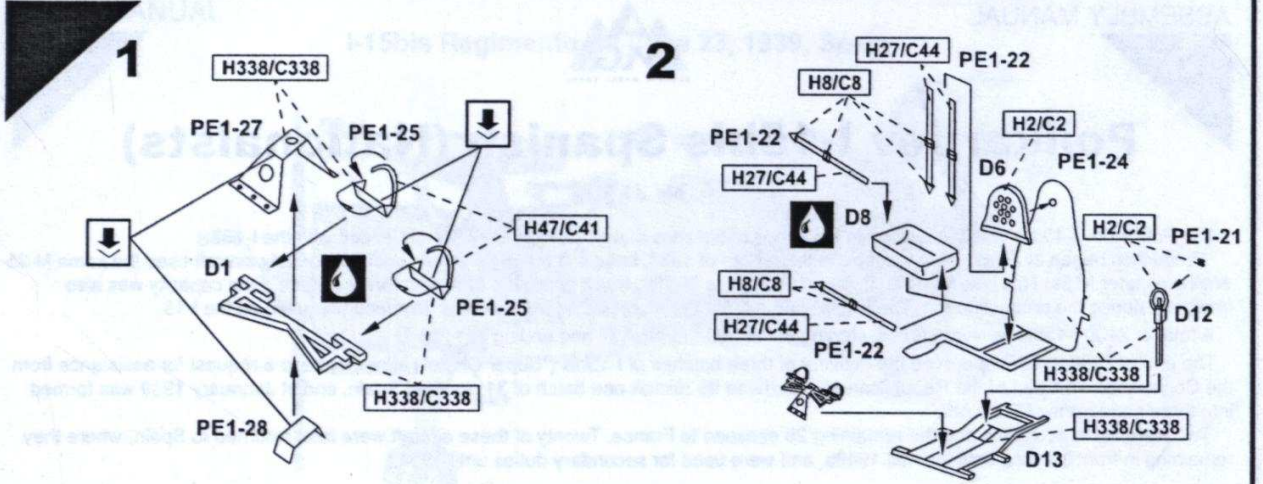

THE CONDITIONAL DENOTATION					УСЛОВНЫЕ ОБОЗНАЧЕНИЯ				
BE CAREFUL ОСТОРОЖНО	DON'T CEMENT НЕ ВЛЕПЛЯТЬ	REMOVE РЕЗАТЬ	SYMMETRICAL СИММЕТРИЧНО	MAKE TWO УДВОИТЬ	OPTIONAL НЕ ОБЯЗАТЕЛЬНО	BEND СОГНУТЬ	OPEN WHOLE СВЕРЛИТЬ	CEMENT КЛЕИТЬ	VARIANTS ВЫБОР ВАРИАНТА

9

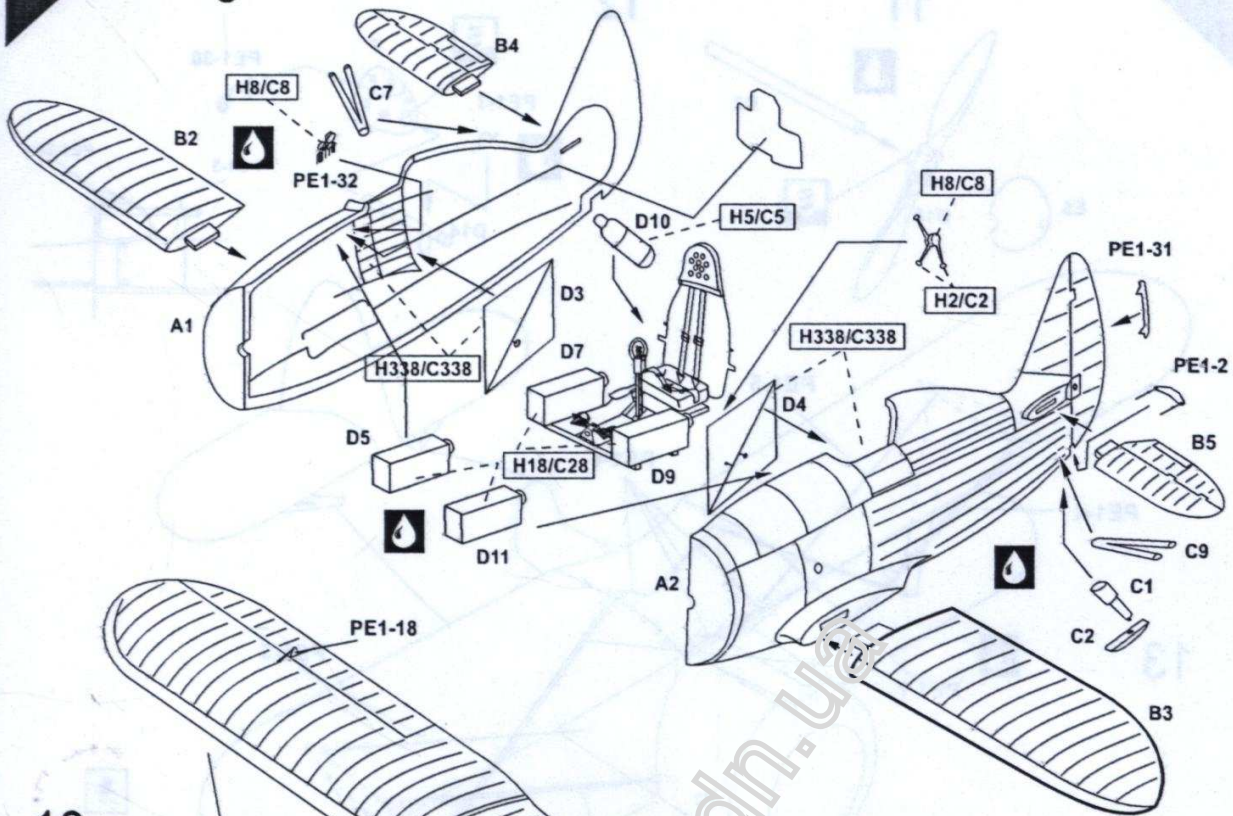

10

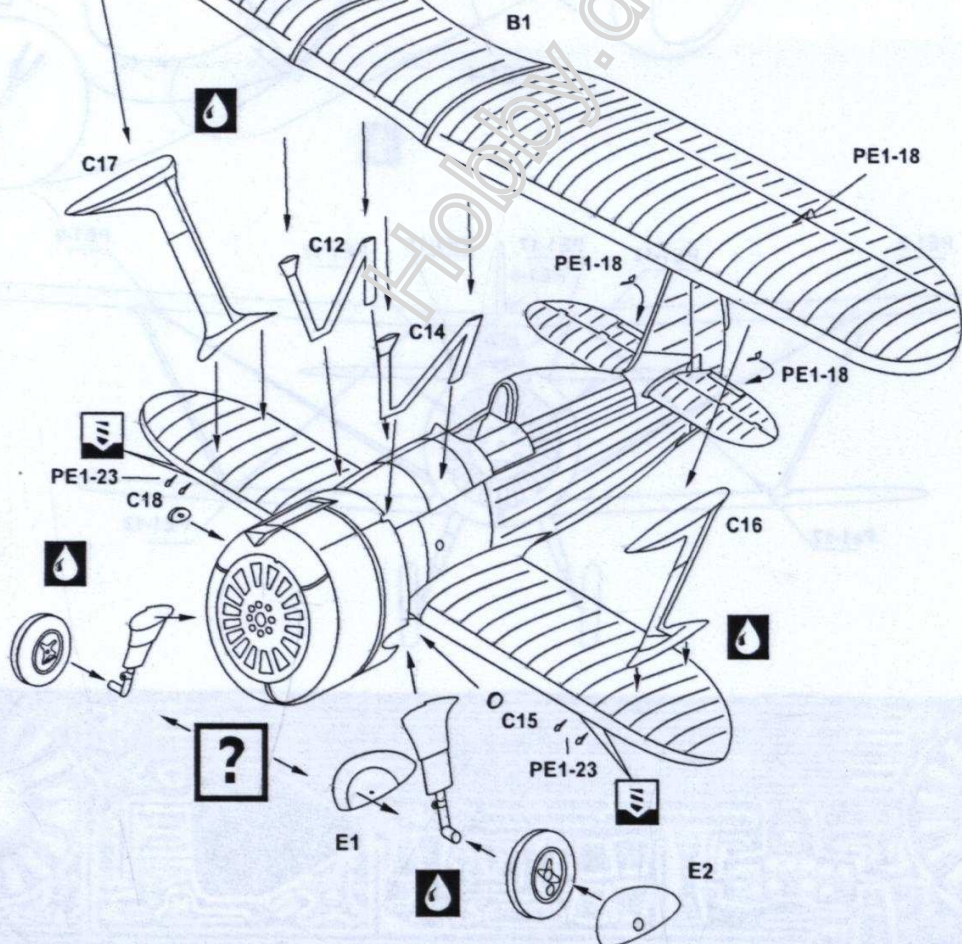

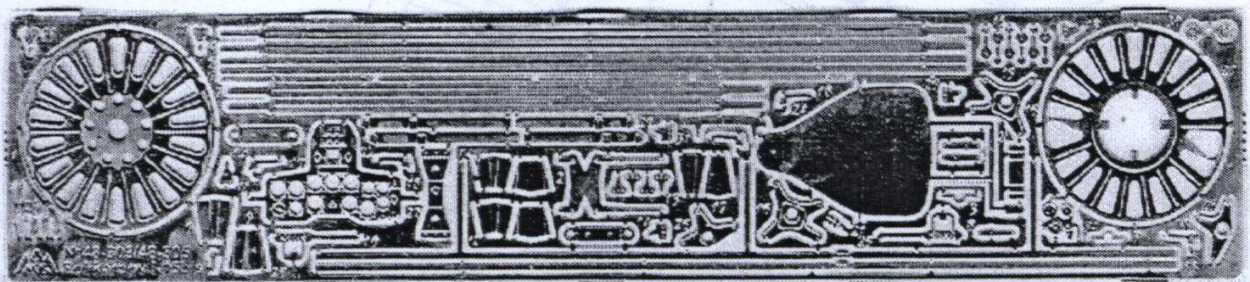
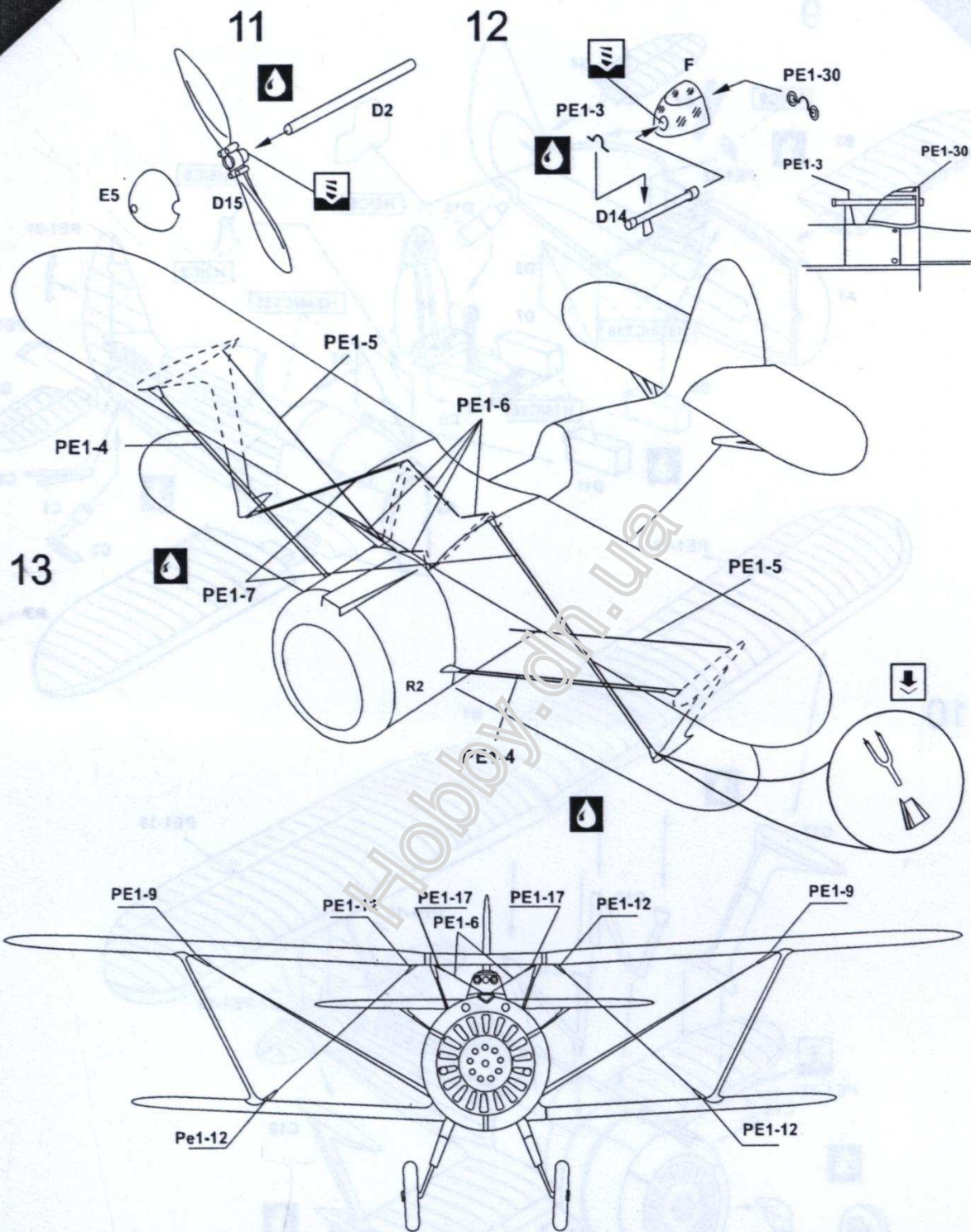

I-15bis of the 24th Gruppo, Reus, 1940, Spain

PAINT MANUAL

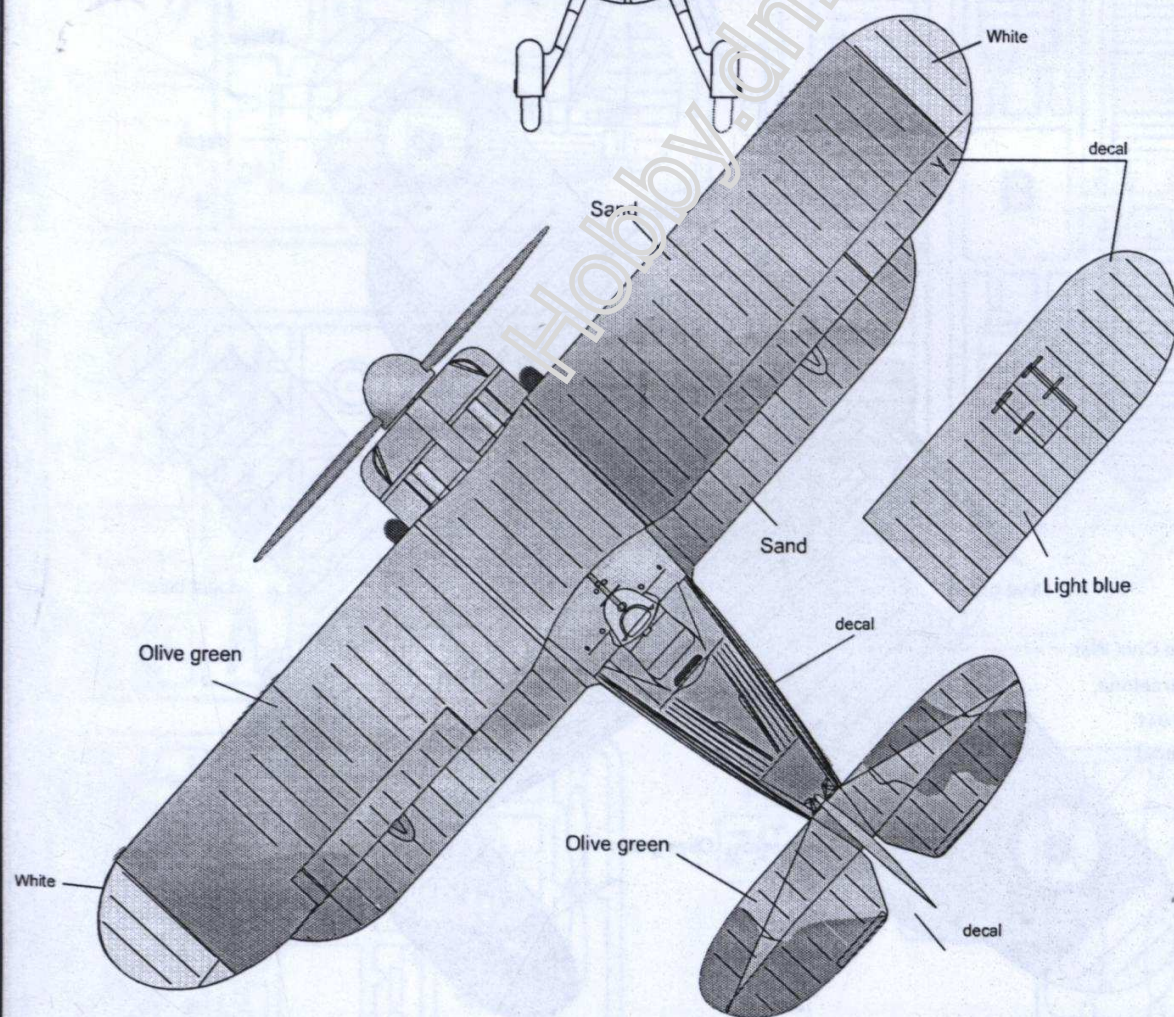
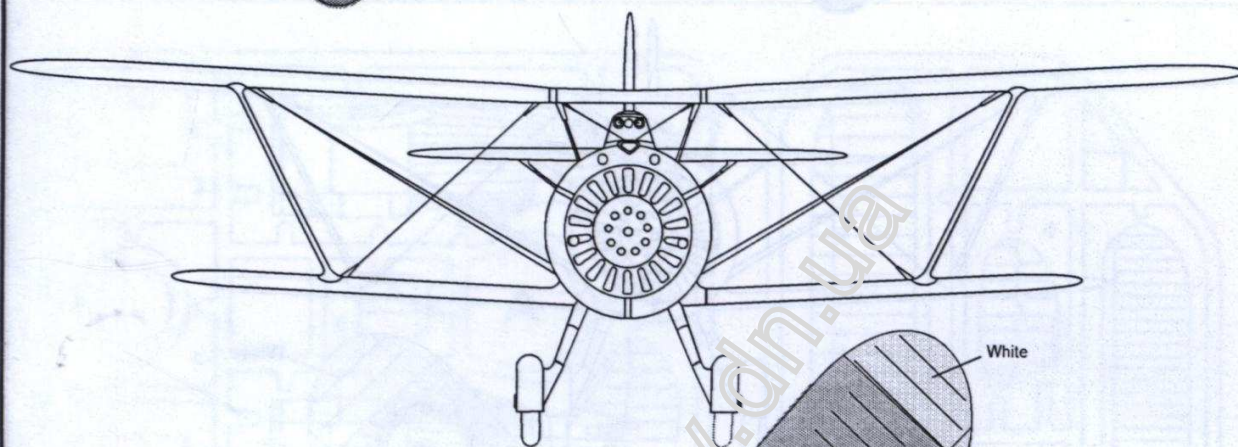
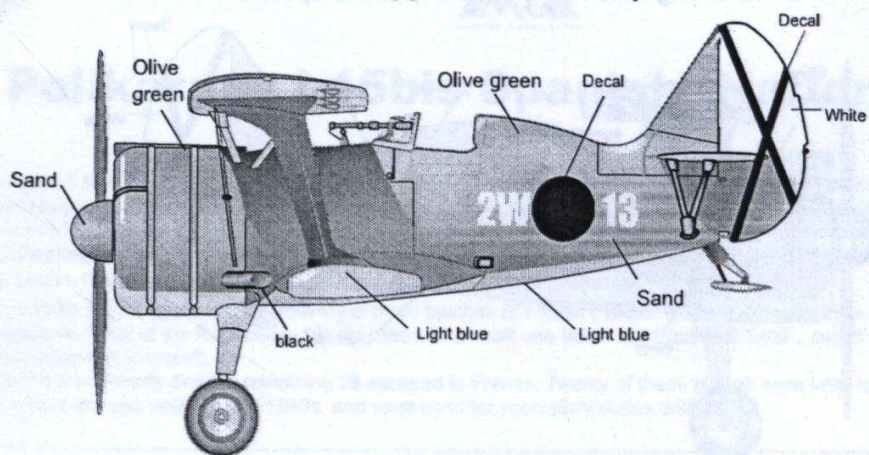

PAINT MANUAL

I-15bis Regimiento de Caza 23, 1939, Spain

