

## Sud-Ouest S.O.1221 Djinn (French - Algerian conflict)

The S.O.1221 Djinn is a French two-seat light helicopter designed and manufactured by aircraft manufacturer Sud-Ouest, which later became Sud Aviation.

The DJINN was the world's first production helicopter to make use of the "cold jet" principle of propulsion.

On 16 December 1953 the first SO 1221 prototype was flown, having a fully enclosed cabin and an all-up weight of 600kg, and on 29 December this aircraft established a new altitude record in its class of 4789.

Chief customer for the SO.1221 has been France's Aviation Legere de l'Armee de Terre (ALAT). The French Army promptly ordered 22 for service trials and by the end of 1960 more than 180 had been built, 100 of which were bought by the French Army & Air Force.

SO.1221 Djinn helicopter's used by the French Army the Algerian Conflict of 1954-1962 as reconnaissance, transport and ambulance service.

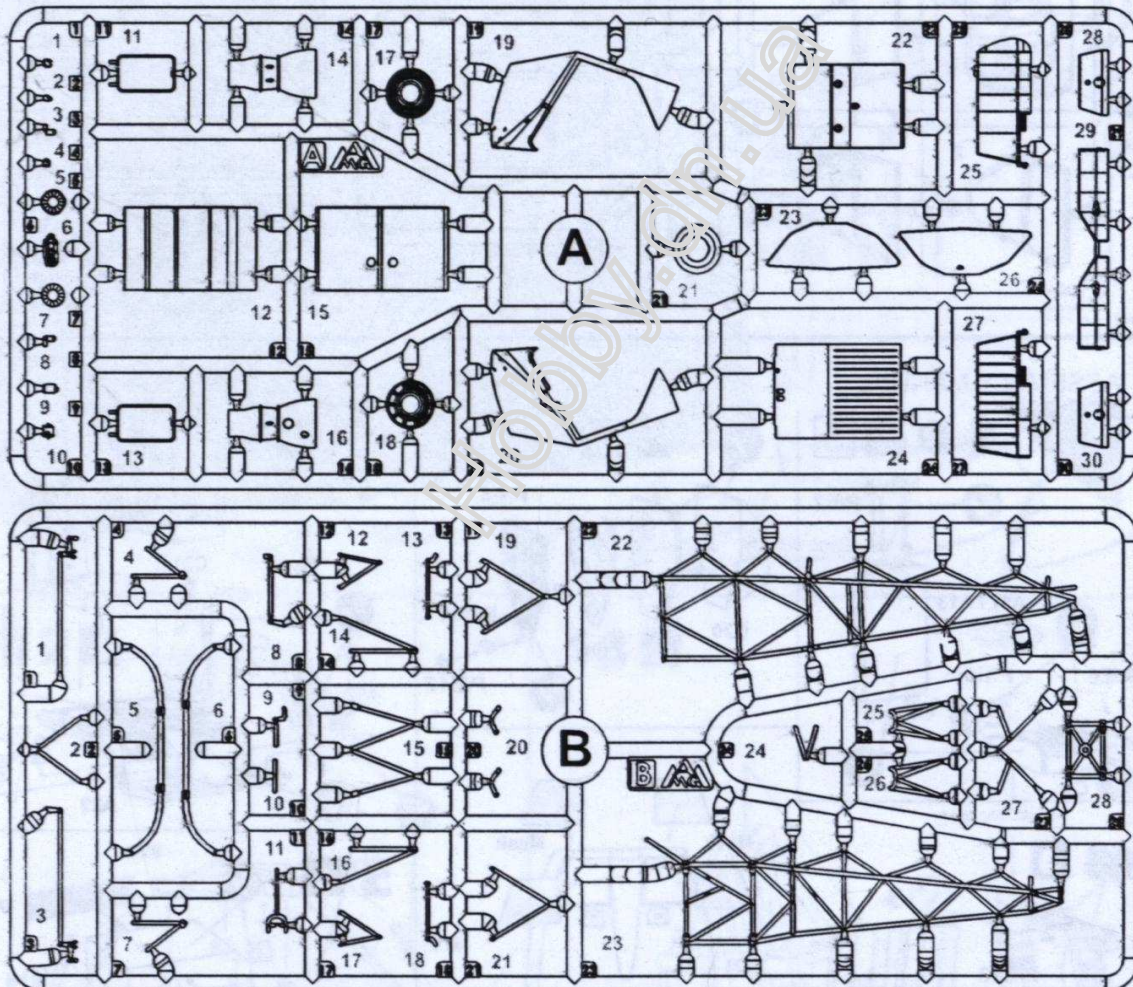

THE CONDITIONAL DENOTATION  
УСЛОВНЫЕ ОБОЗНАЧЕНИЯ



TO PAINT  
ОКРАСИТЬ



DON'T CEMENT  
НЕ КЛЕИТЬ



REMOVE  
РЕЗАТЬ



SYMMETRICAL  
СИММЕТРИЧНО



MAKE TWO  
УДВОИТЬ



OPTIONAL  
НЕОБЯЗАТЕЛЬНО



BEND  
СОГНУТЬ



OPEN WHOLE  
СВЕРЛИТЬ



CEMENT  
КЛЕИТЬ



VARIANTS  
ВЫБОР ВАРИАНТА

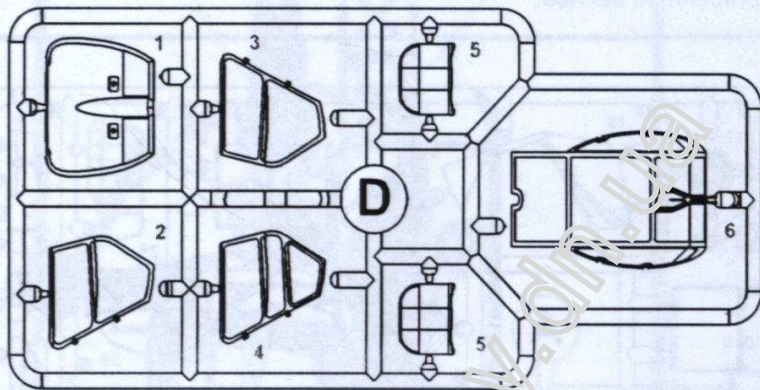
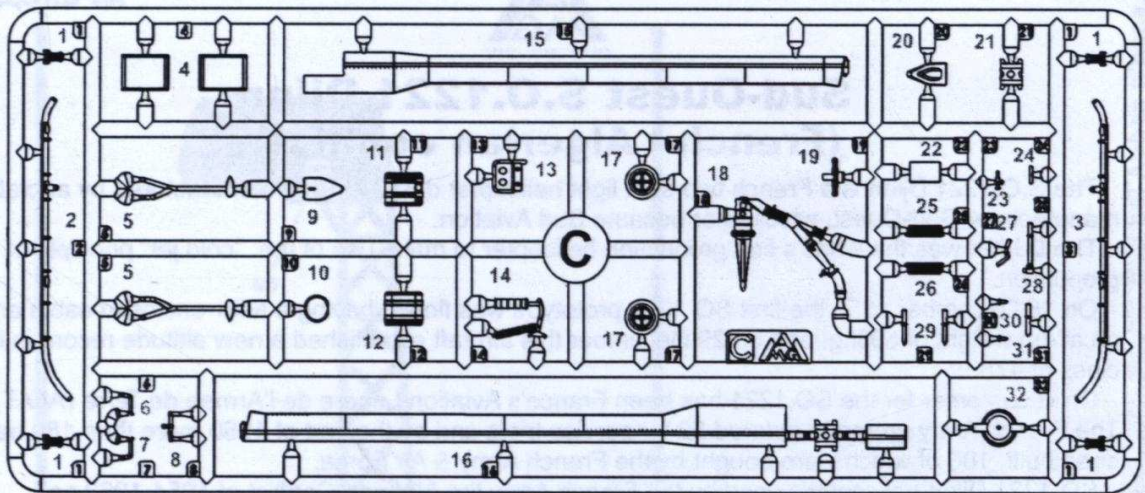

Decal

Film



P/E

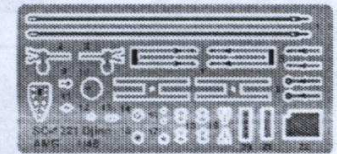

ASSEMBLY MANUAL

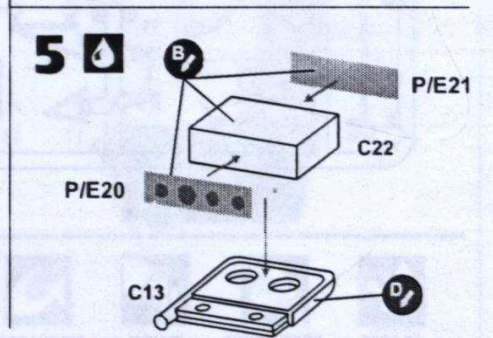
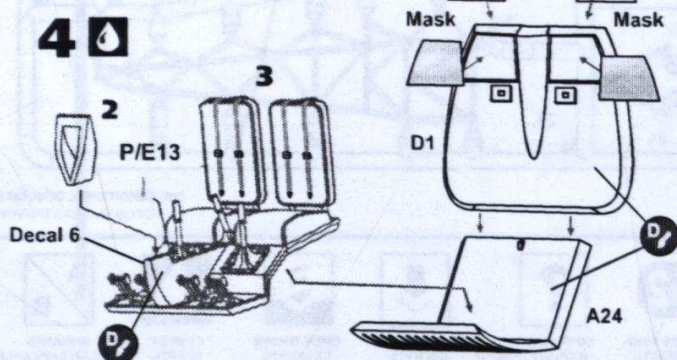
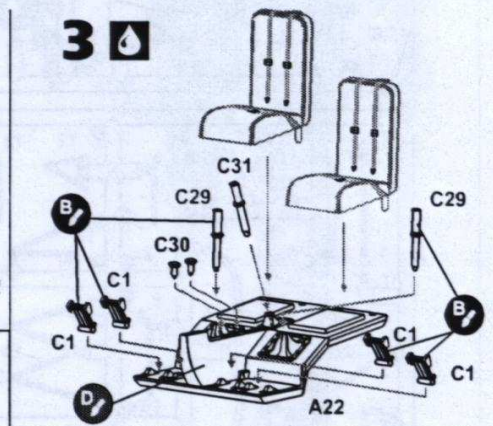
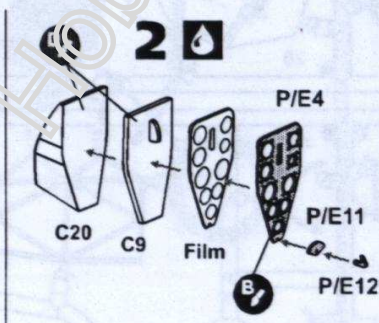
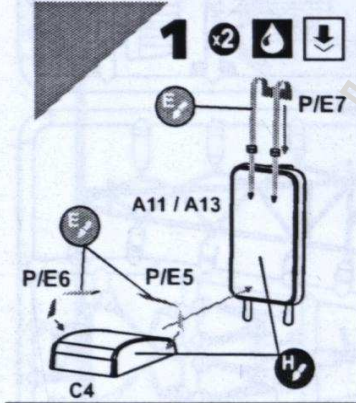

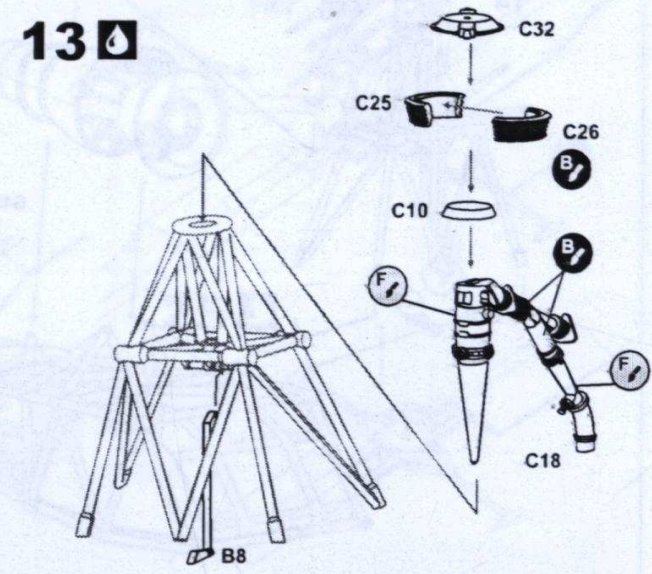
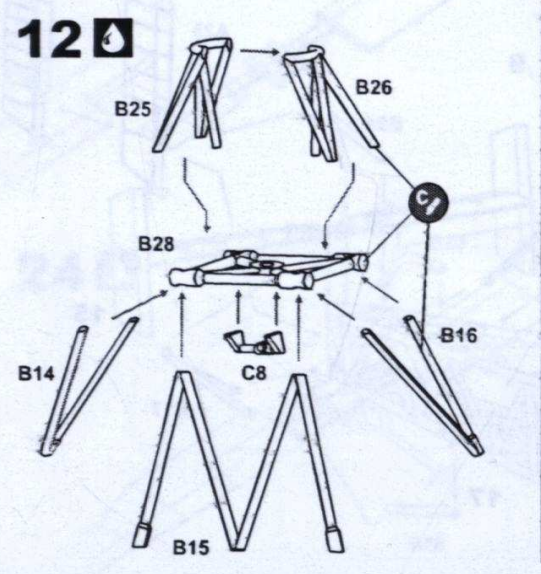
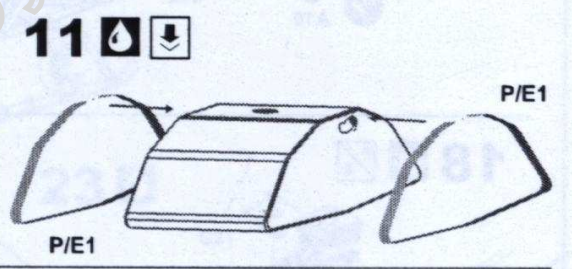
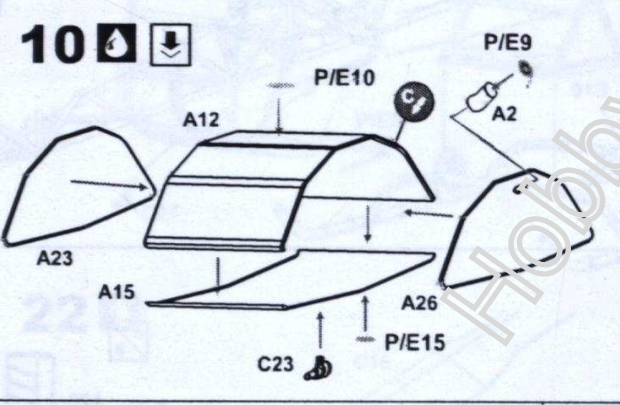
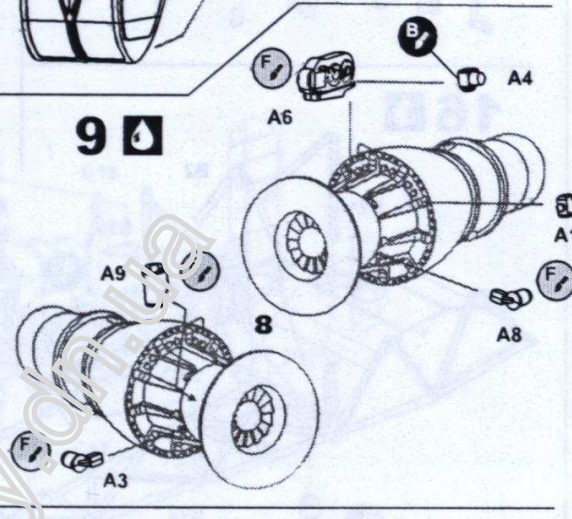
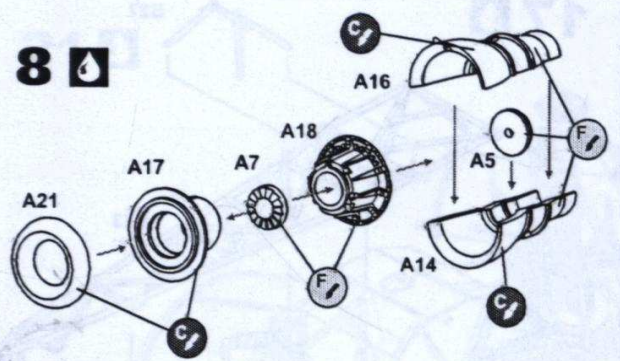
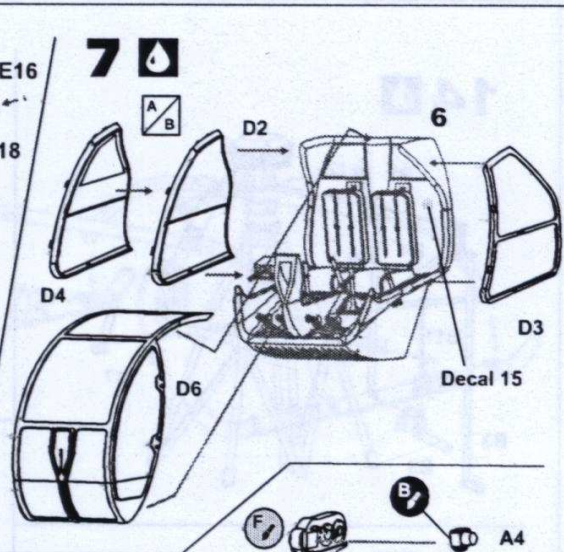
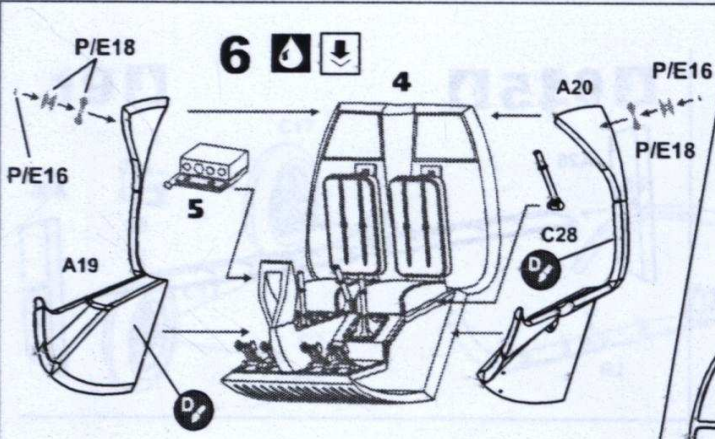

14

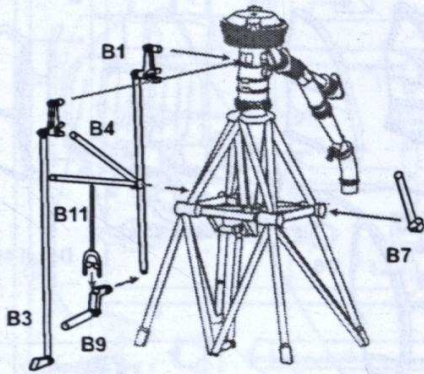

15

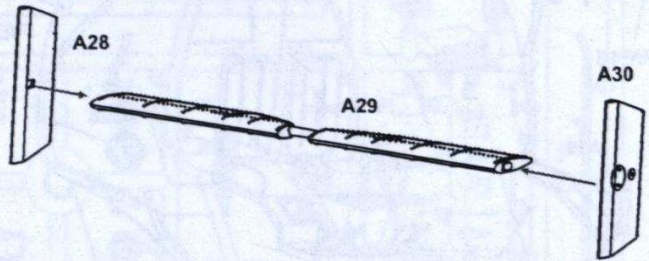

16

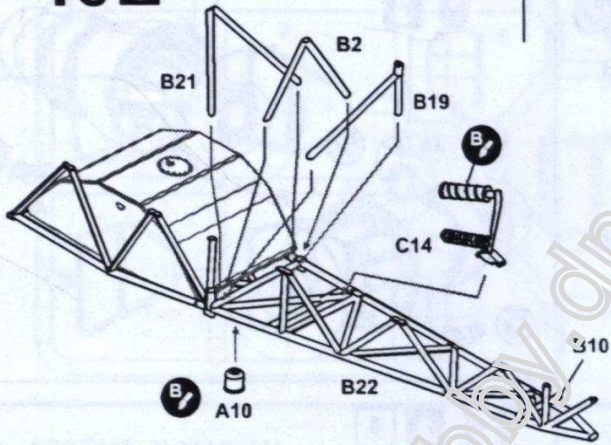

17

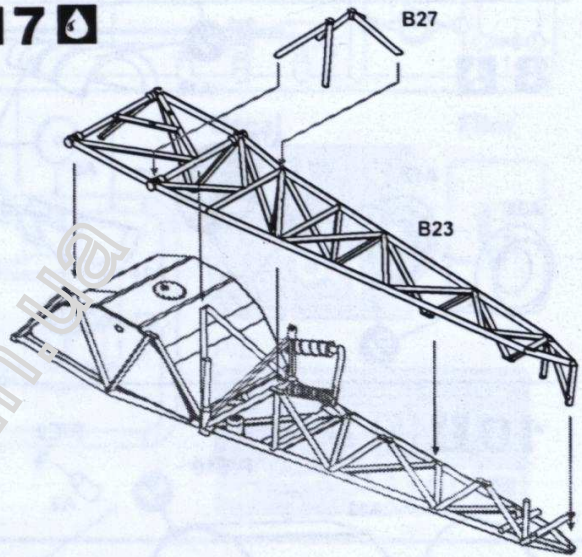

18

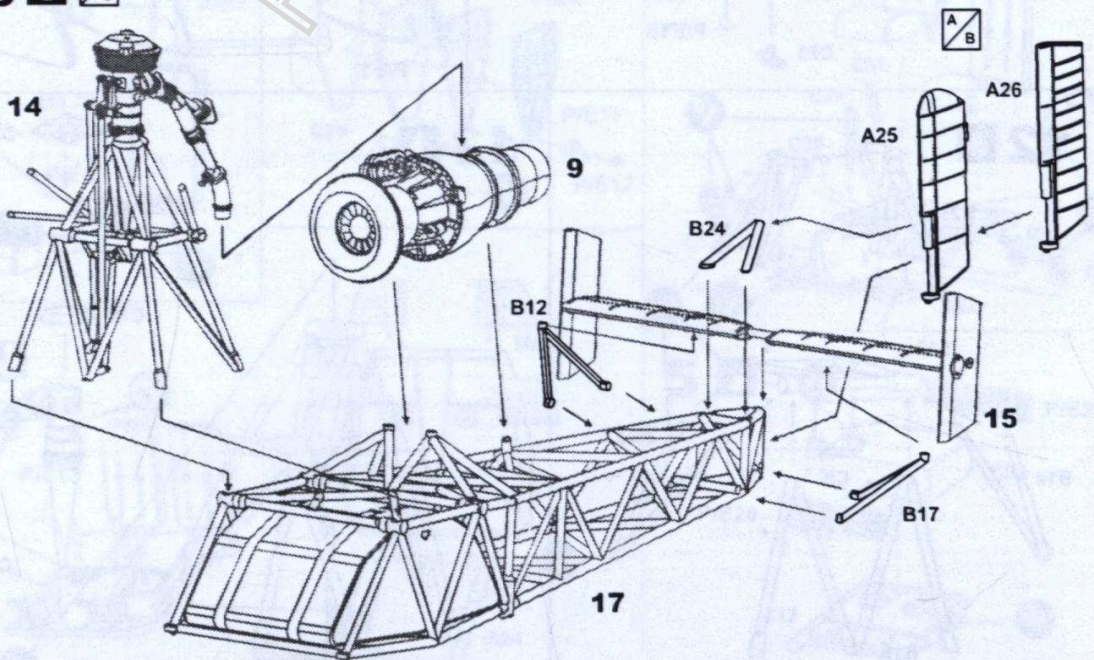

19

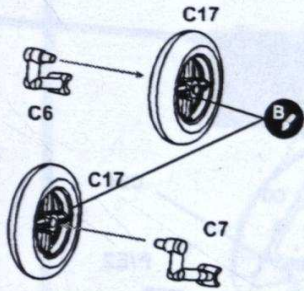

20

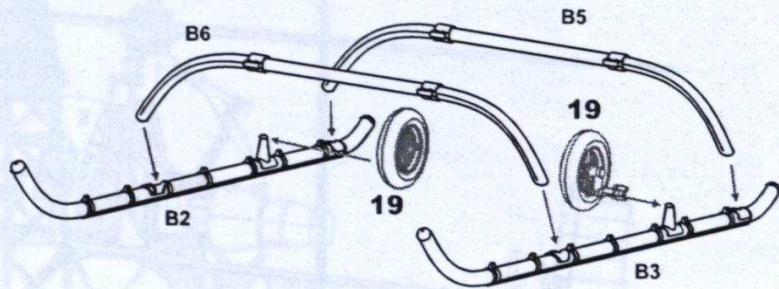

21

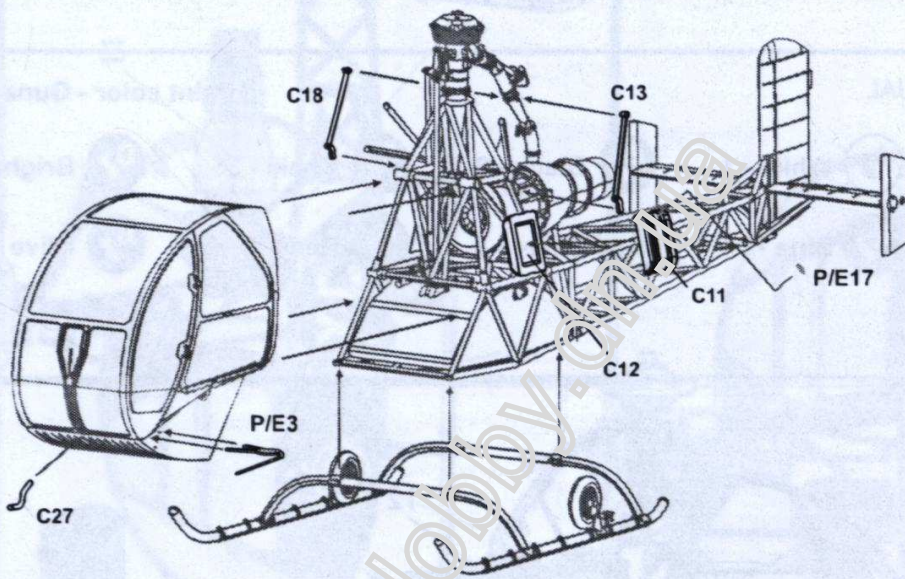

22

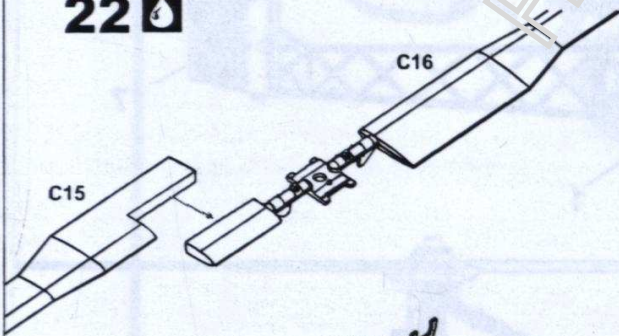

23

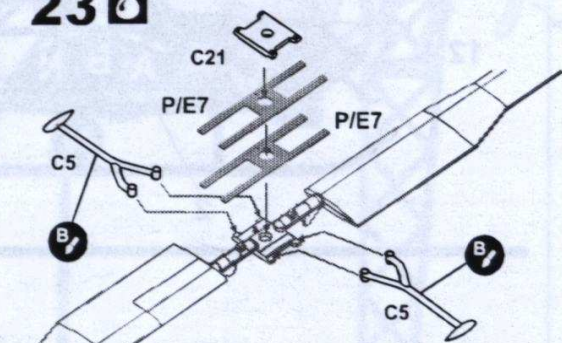

24

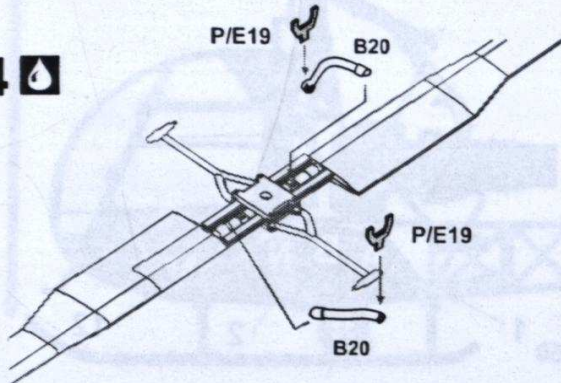

25

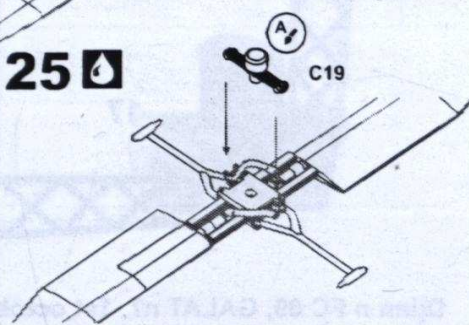

26

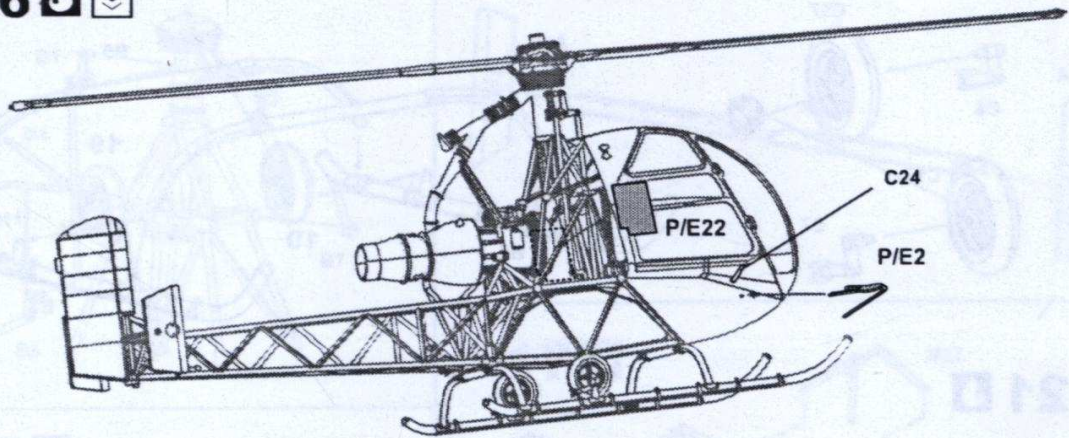

PAINT MANUAL

Paint color - Gunze Mr.Color

- |  |  |  |  |
|--|--|--|--|
|  |  |  |  |
|  |  |  |  |

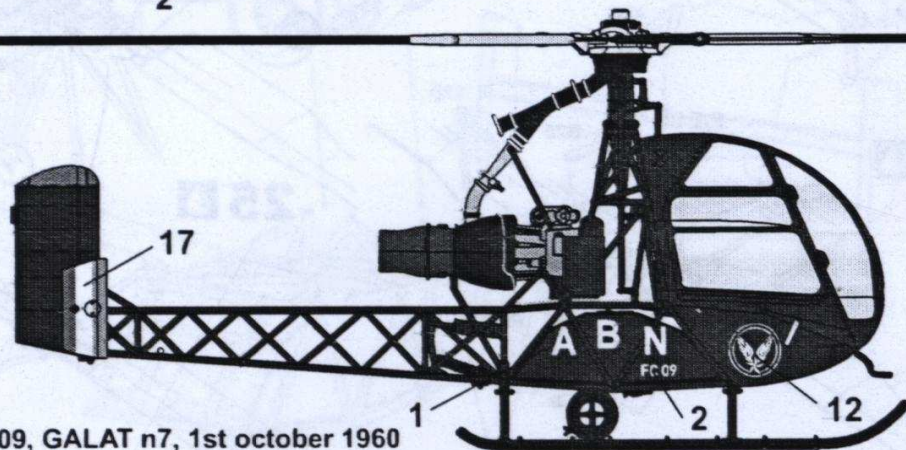
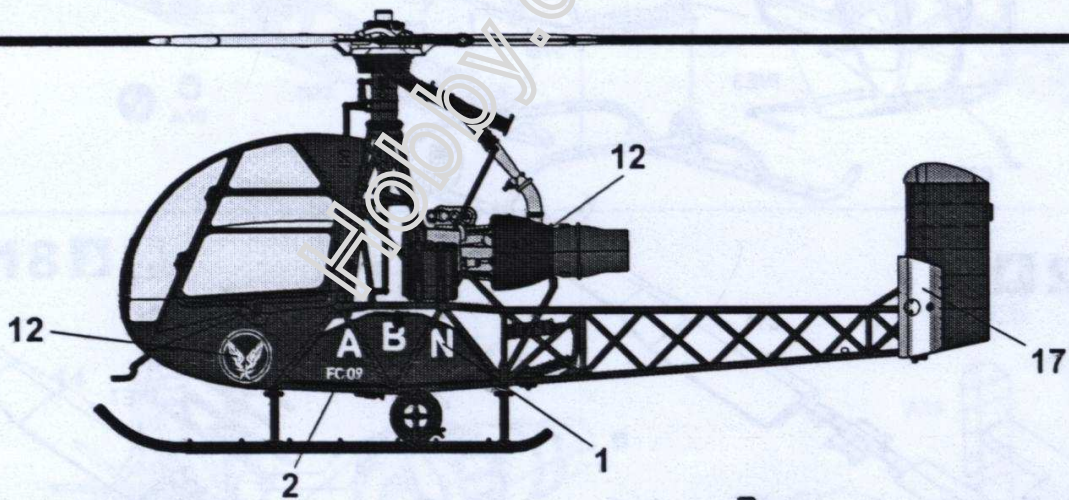

Djinn n FC 09, GALAT n7, 1st october 1960

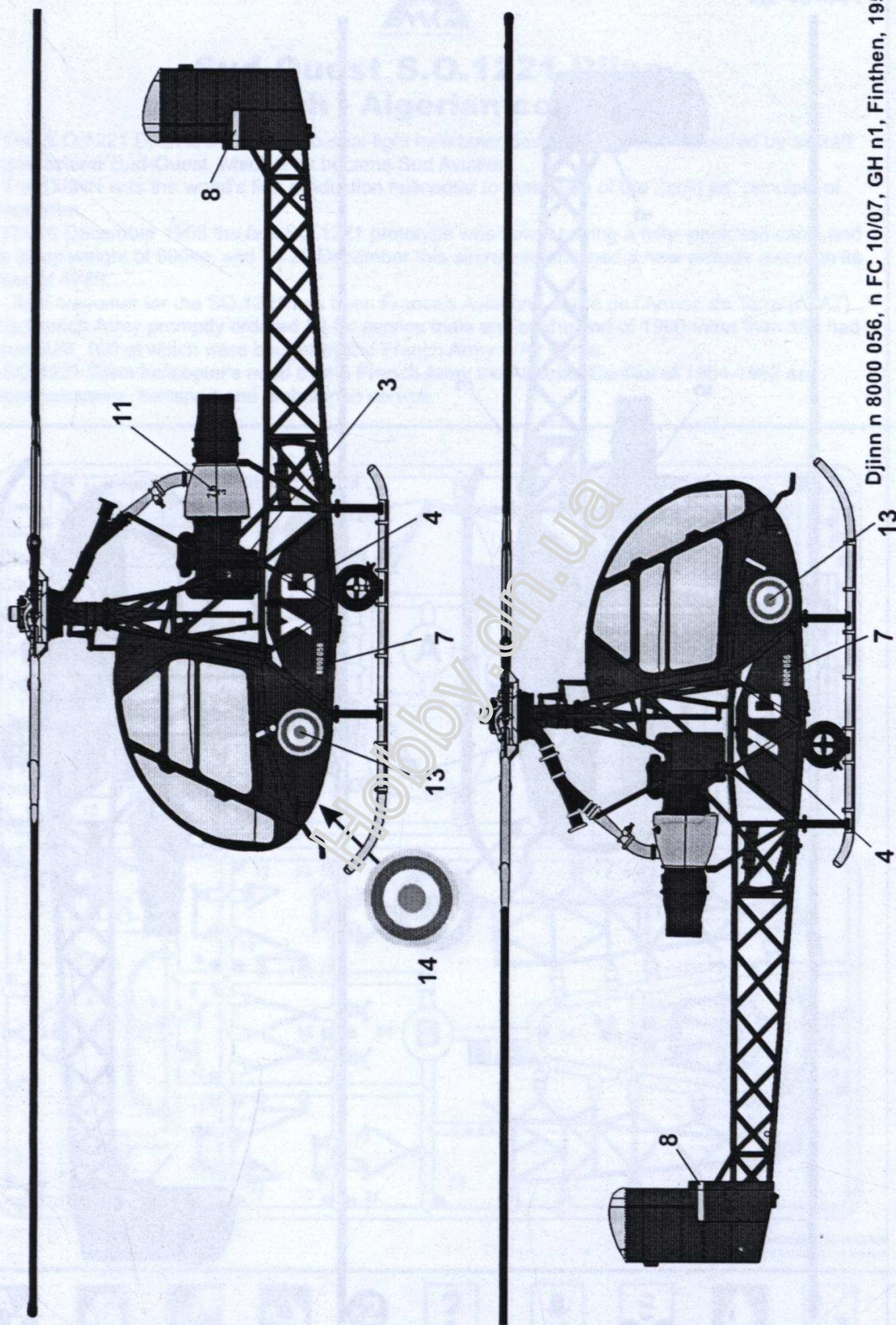

Djinn n 8000 056, n FC 10/07, GH n1, Finthen, 1959

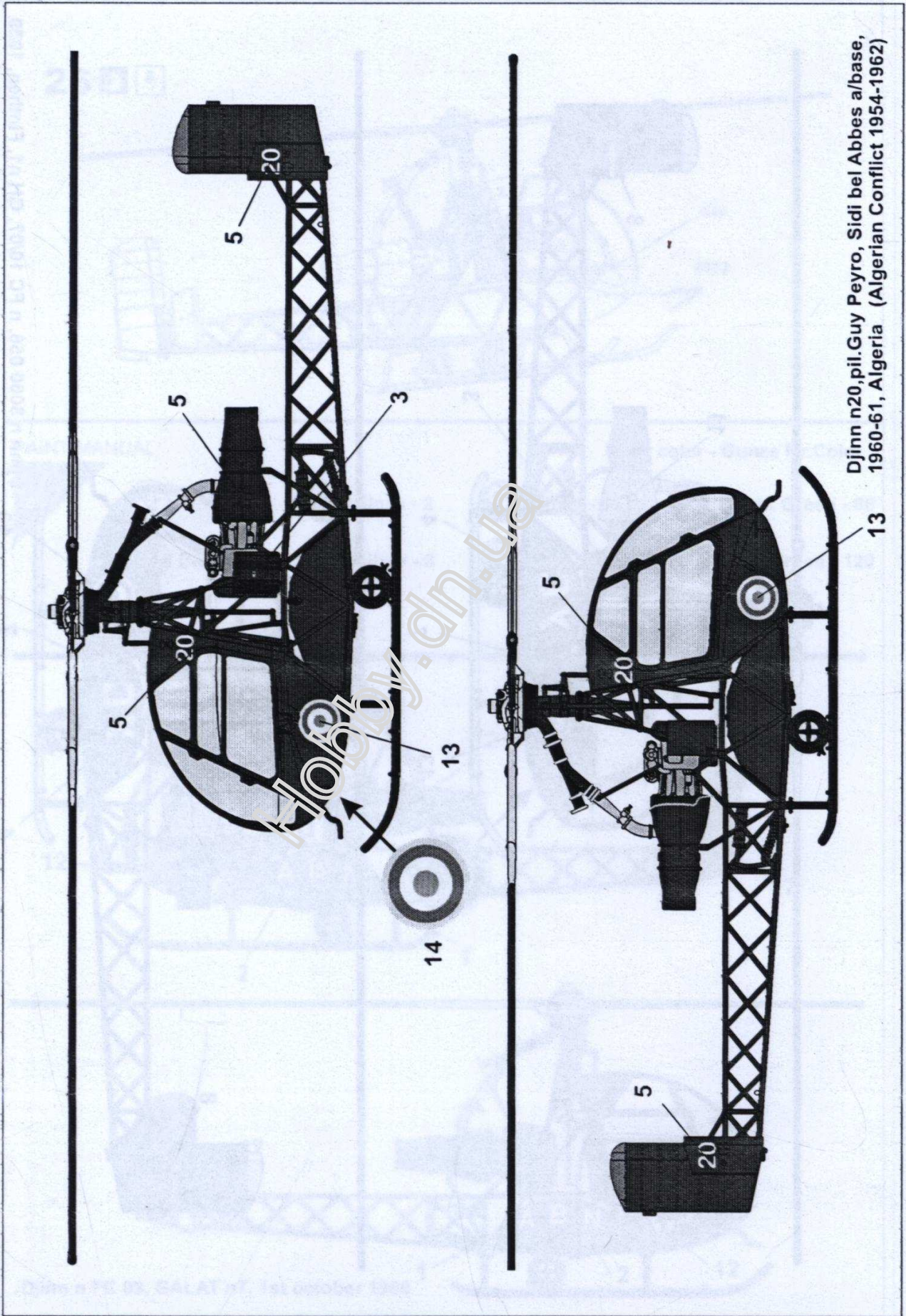

Djinn n20, pil. Guy Peyro, Sidi bel Abbes a/base, 1960-61, Algeria (Algerian Conflict 1954-1962)

13