



Bell P-63C Kingcobra

The P-63 KINGCOBRA fighters were developed from some of the generated during the XP-39E AIRACOBRA project. Production for P-63 aircraft began in 1943, and the first examples were delivered in october of that year.

The Soviet Union AF was in dire need offighter aircraft and were already a prime operator of the P-39 series. The P-63 seemed like another good match for the VVS RKKA arsenal and, with input from Soviet test-pilot A Kochetkov, the P-63 Kingcobra was modified for the better and ultimately shipped to the Soviet Union from Nome, Alaska, to be used solely against Japanese forces in the East. Despite this "agreement" on the part of the USSR, P-63 air groups were set up in the West to battle the Germany.

The P-63 exelled in the ground attack role, providing for adequate low flying characteristics and a concentrated dose of lethal armament making them ideal tank busters. Engaging and downing enemy fighters also something of a rarity but still possible.

Soviet use of the P-63 amounted to over 72% of all Kingcobras produced (3303 were built), making them the primary operator of the aircraft.

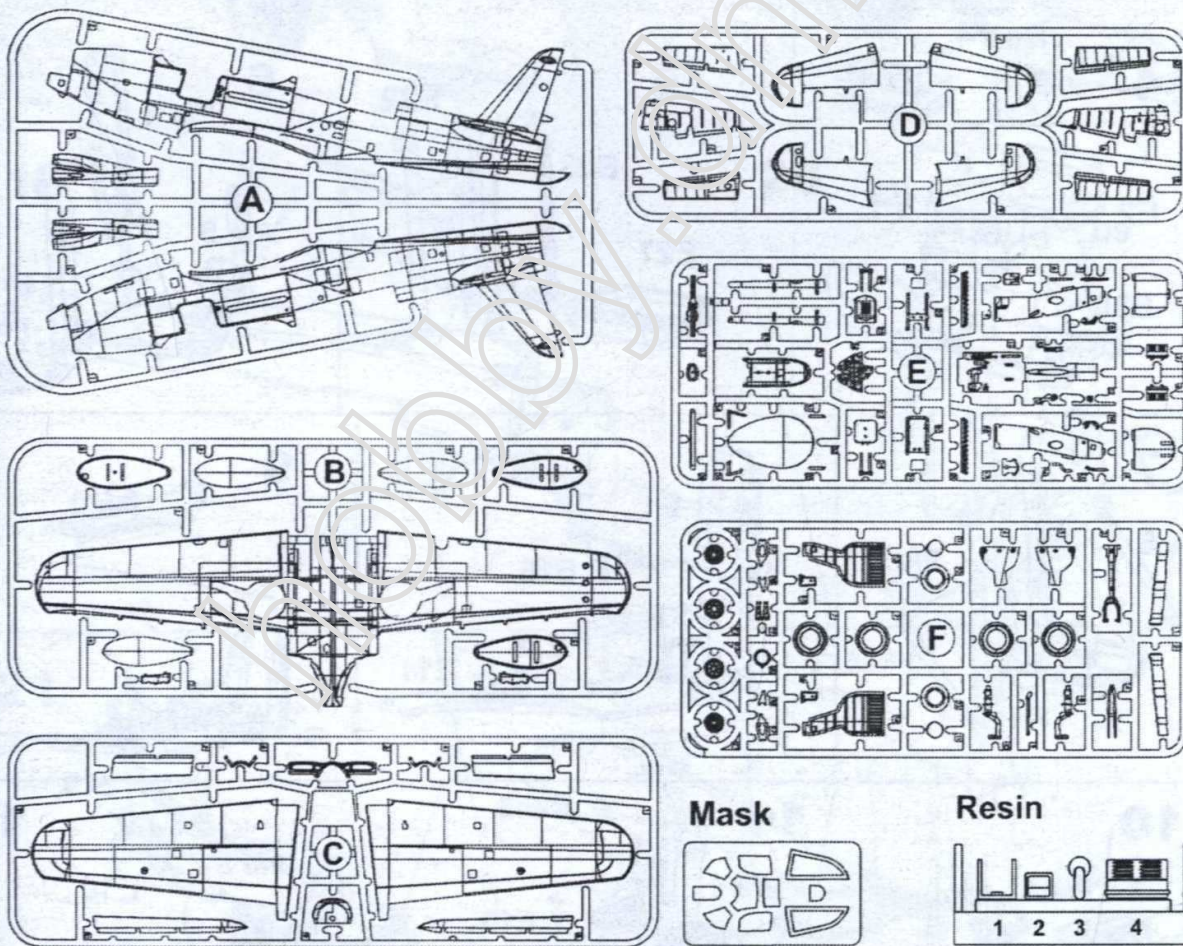

Mask

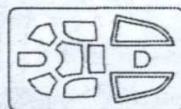



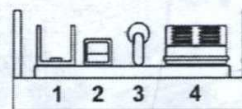







Resin



THE CONDITIONAL DENOTATION

УСЛОВНЫЕ ОБОЗНАЧЕНИЯ

- 
BE CAREFUL
ОСТОРОЖНО
- 
DON'T CEMENT
НЕ КЛЕИТЬ
- 
REMOVE
РЕЗАТЬ
- 
SYMMETRICAL
СИМЕТРИЧНО
- 
MAKE TWO
УДВОИТЬ
- 
OPTIONAL
НЕОБЯЗАТЕЛЬНО
- 
BEND
СОГНУТЬ
- 
OPEN WHOLE
ОТКРЫТЬ
- 
CEMENT
КЛЕИТЬ
- 
VARIANTS
ВЫБОР БАРНА-ТА

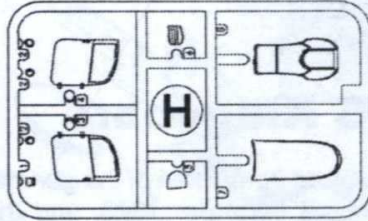
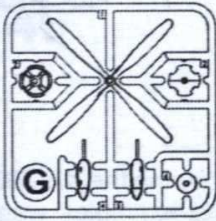

P/e

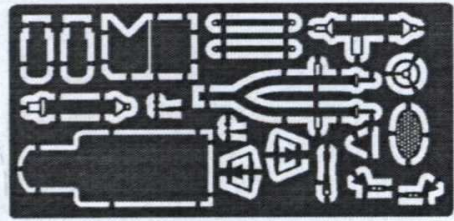

ASSEMBLY MANUAL

1 x2

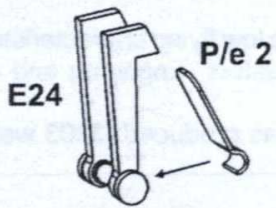

2

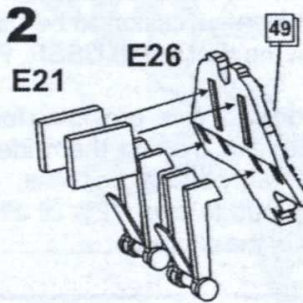

3

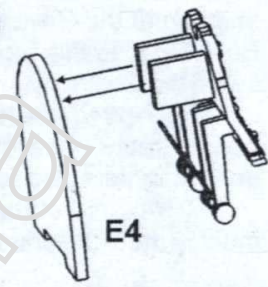

4

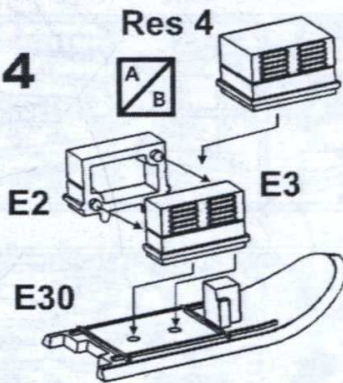

5

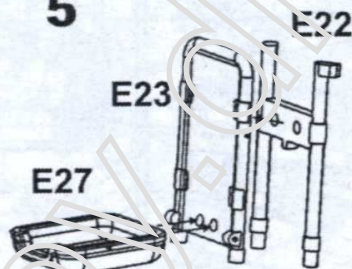

6

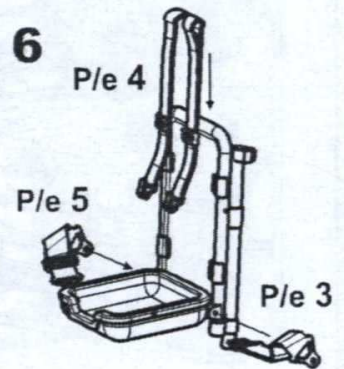

7

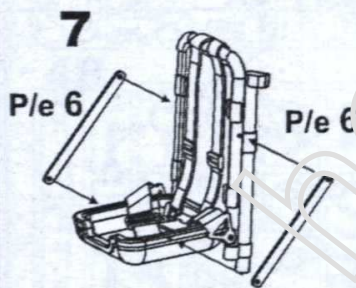

8

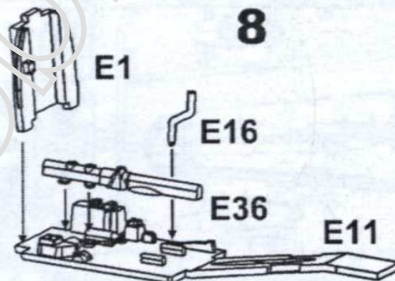

9

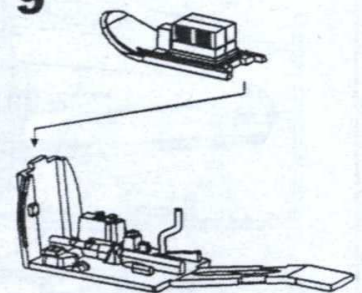

10

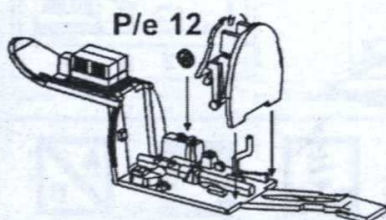

11

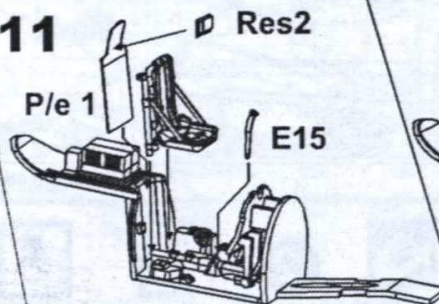

12

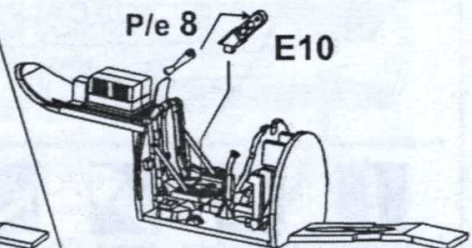

14

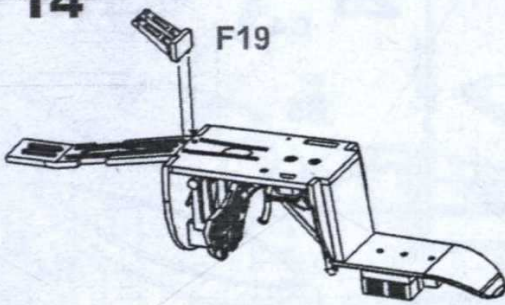

15 x2

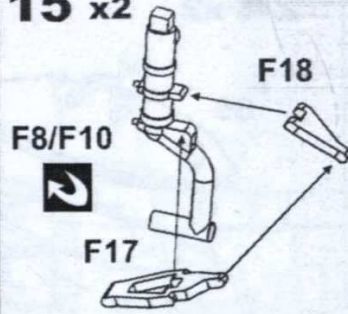

16 x2

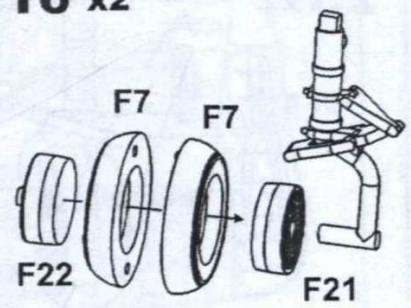

17

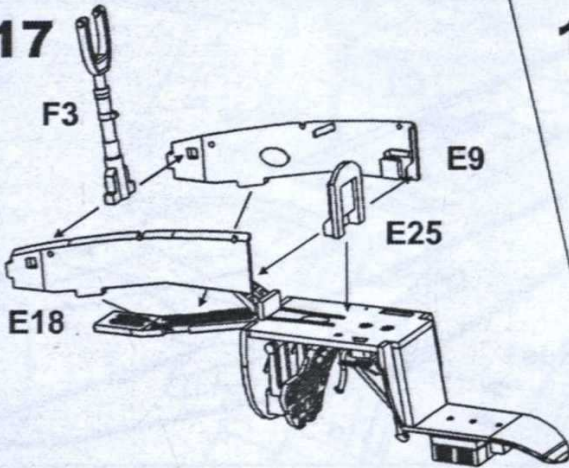

18

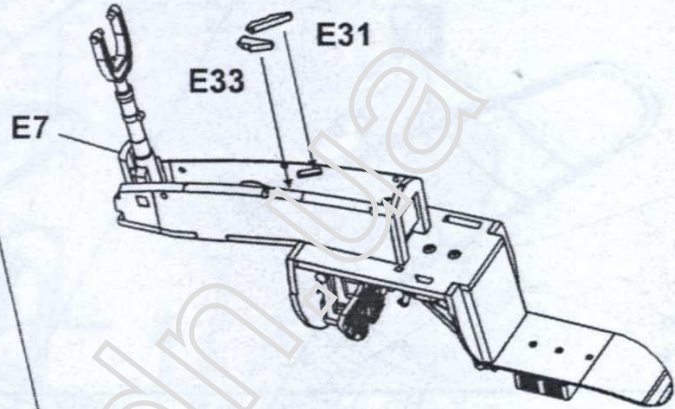

19

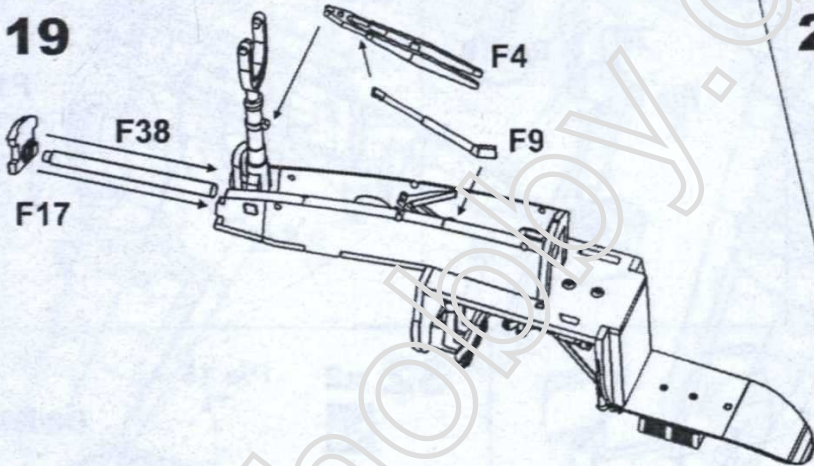

20

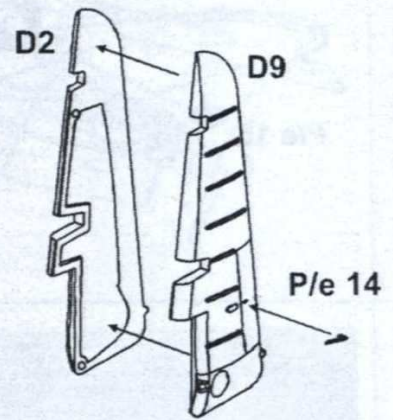

21

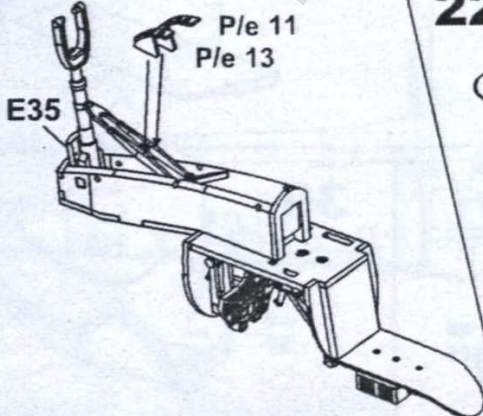

22

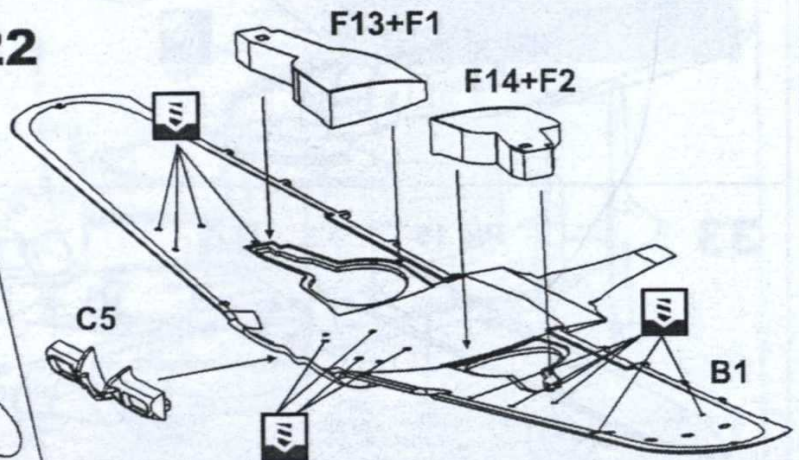

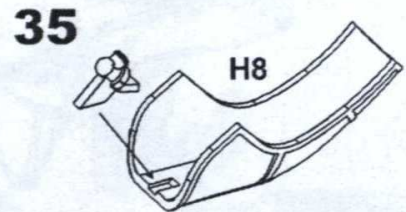
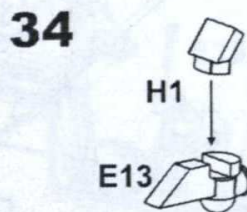
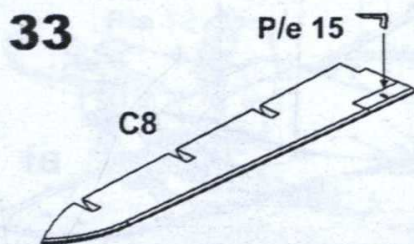
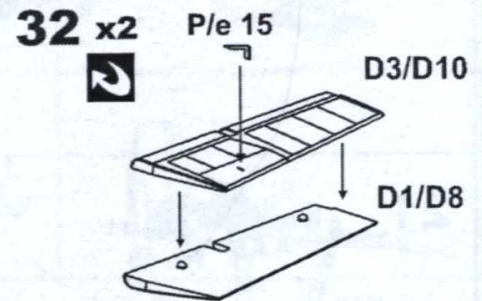
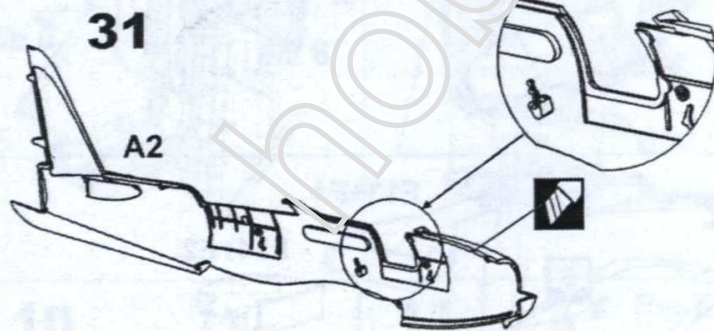
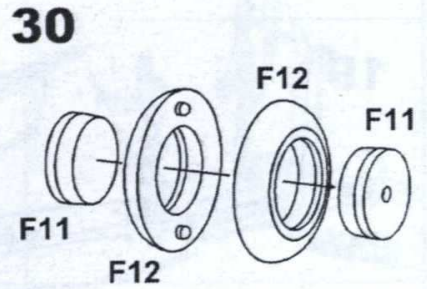
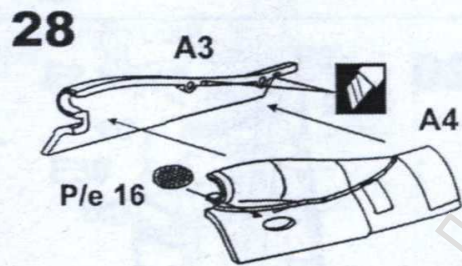
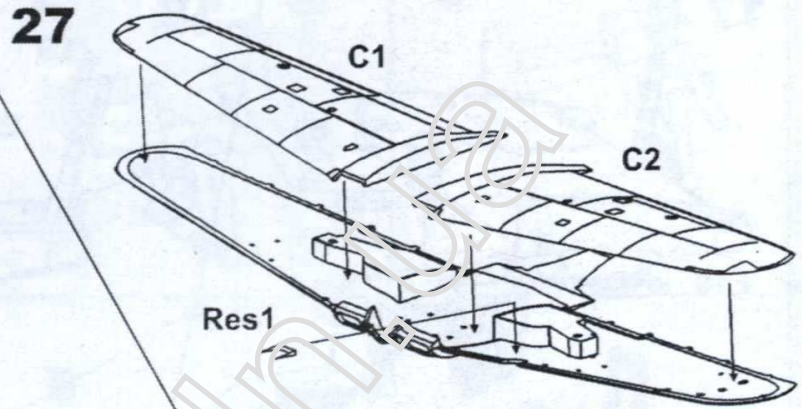
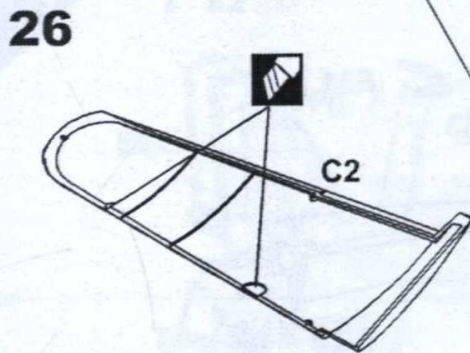
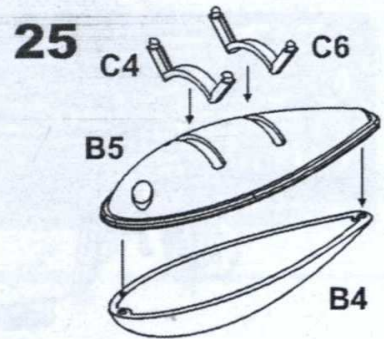
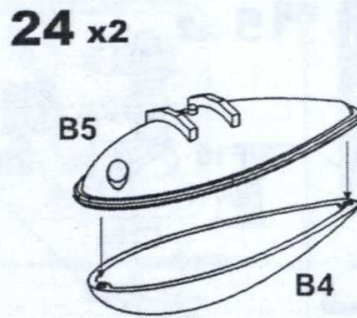
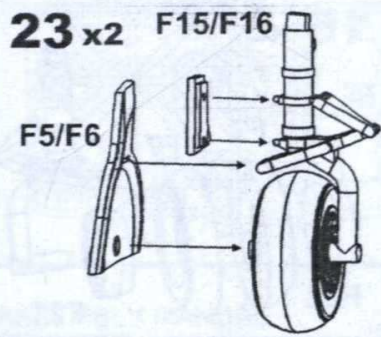

36

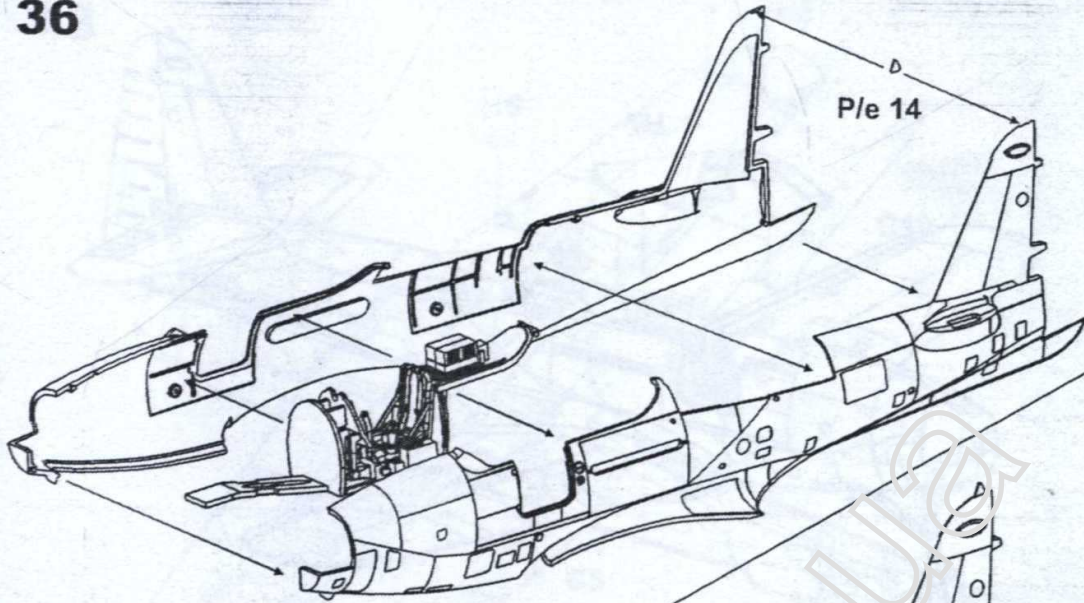

37

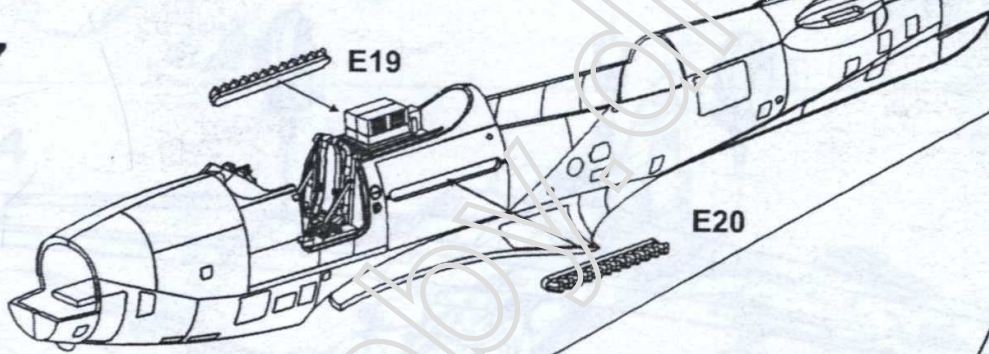

38

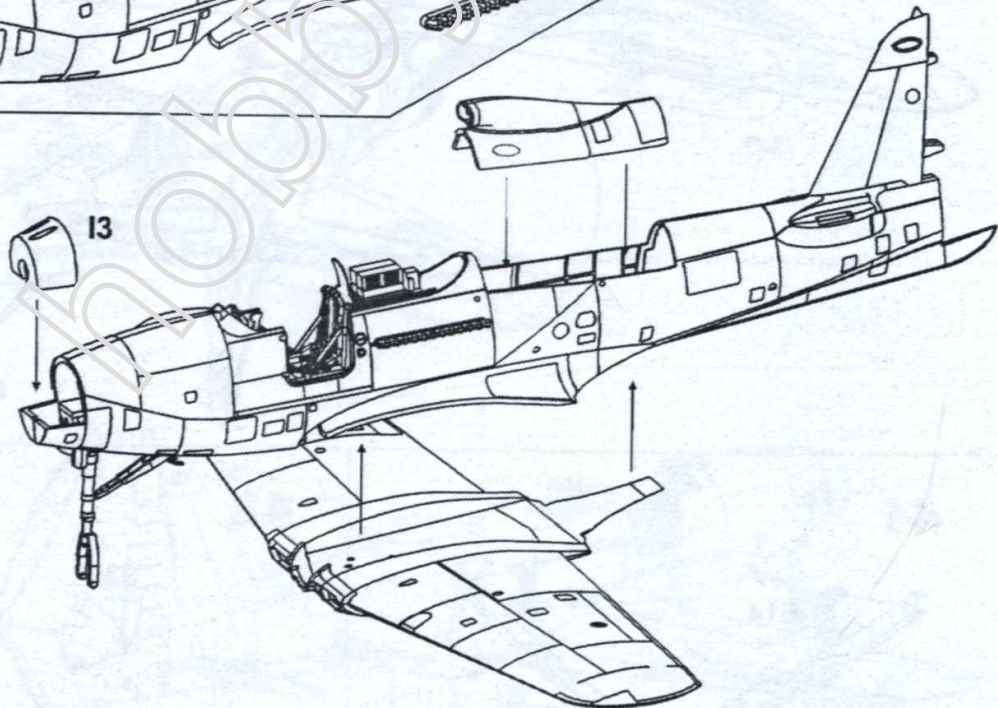

39

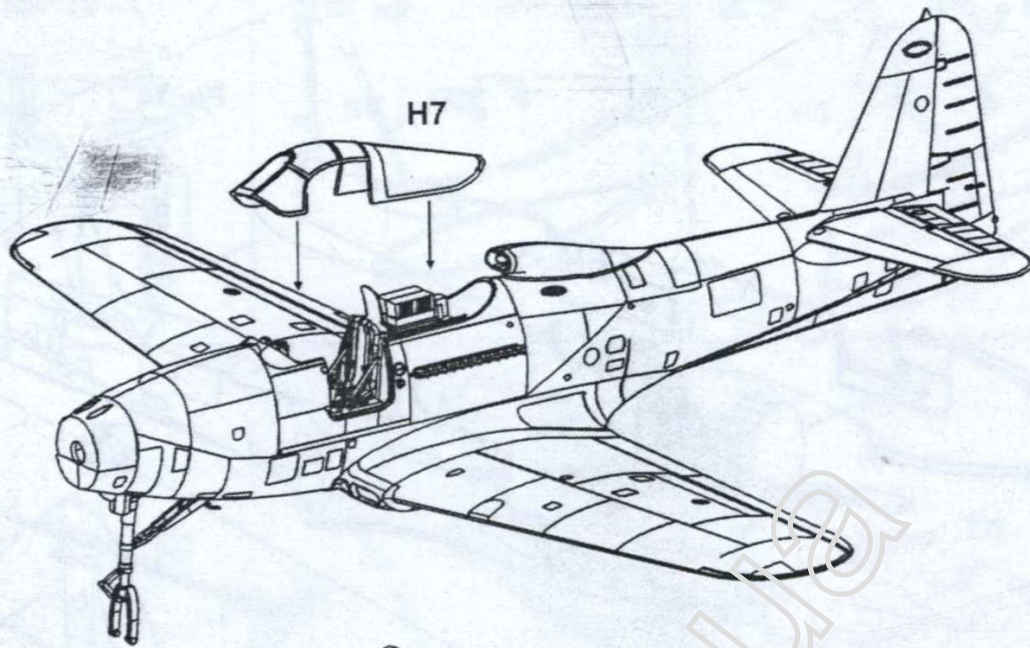

40

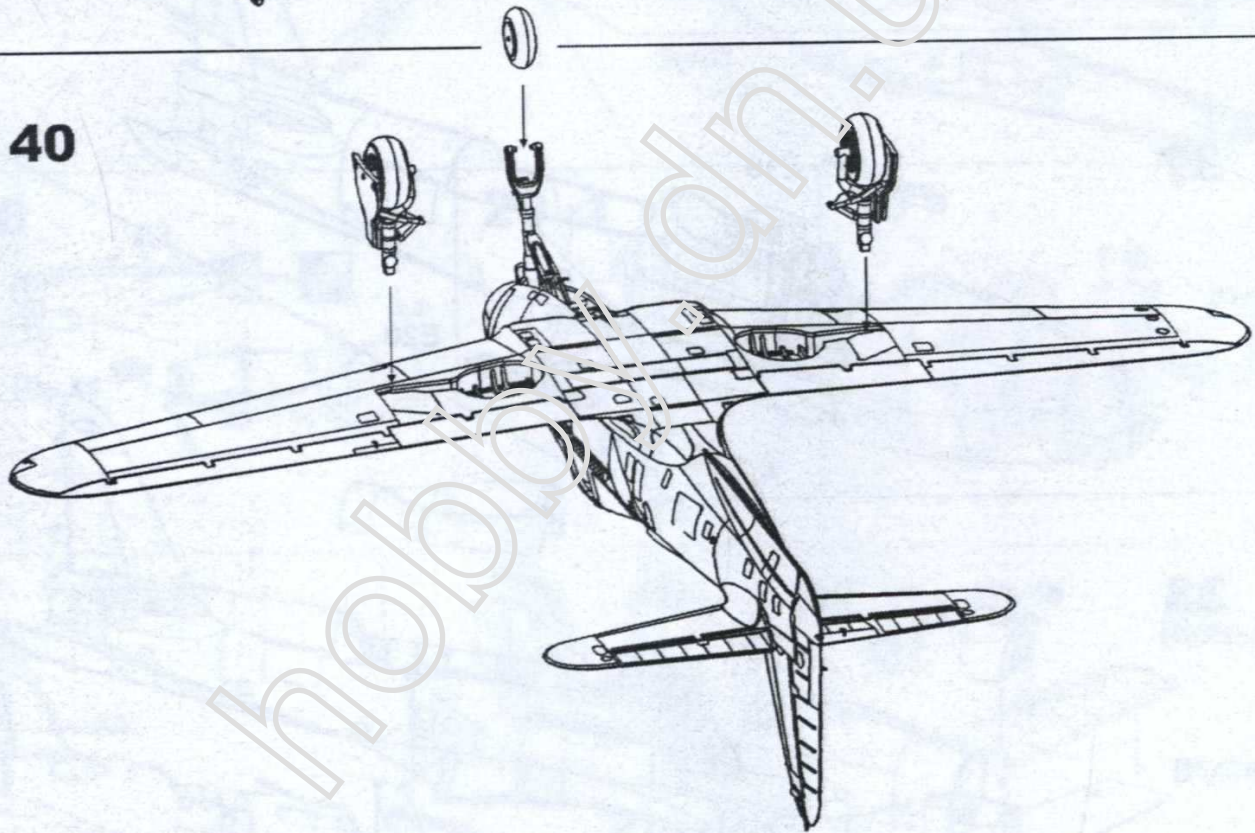

41

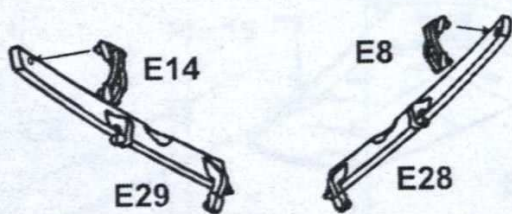

42

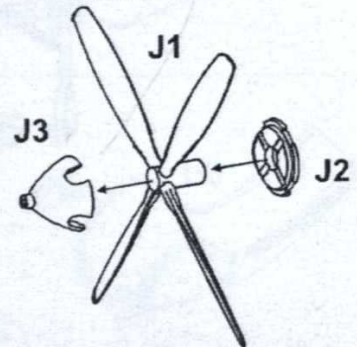

43

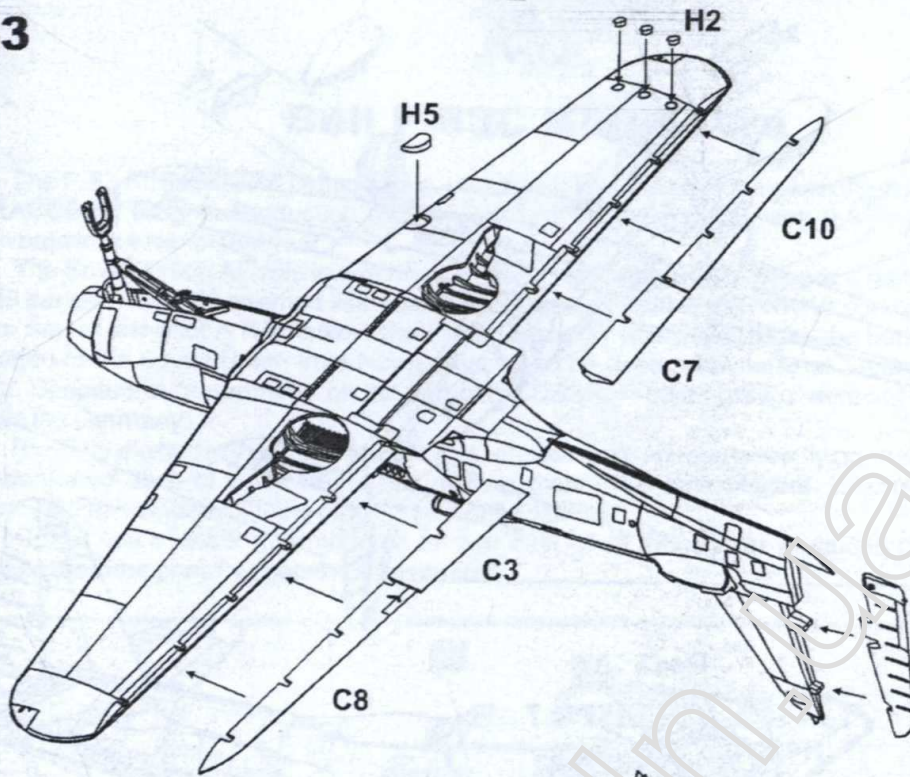

44

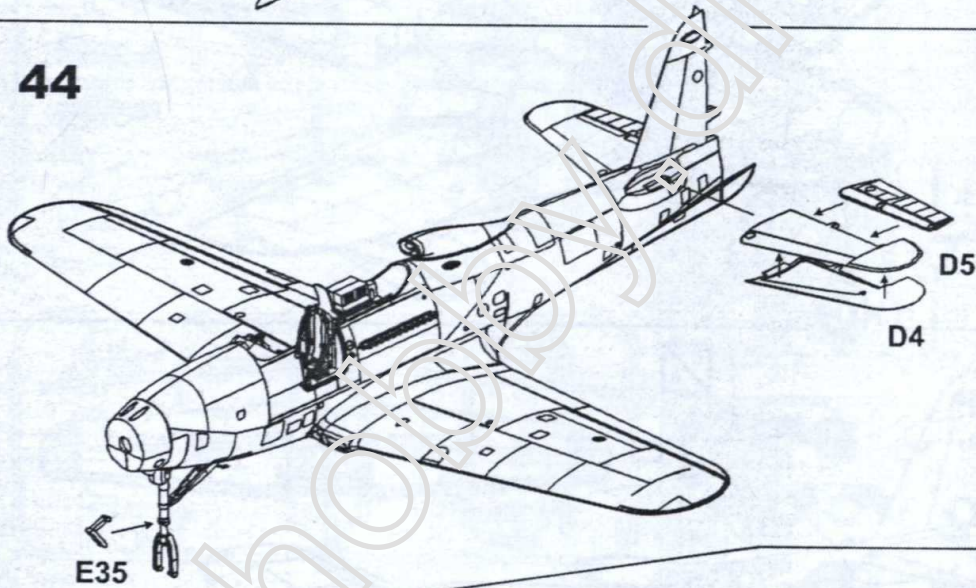

45

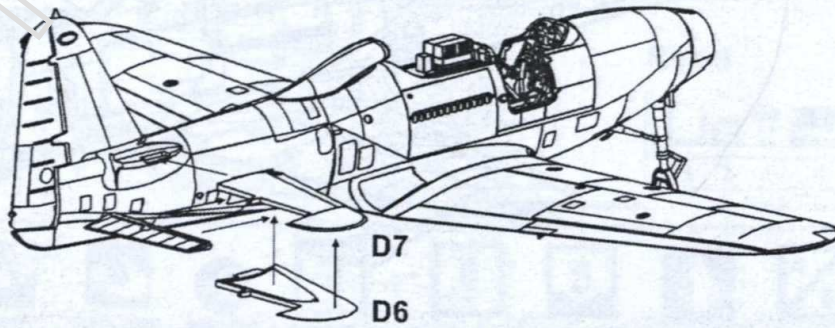

46

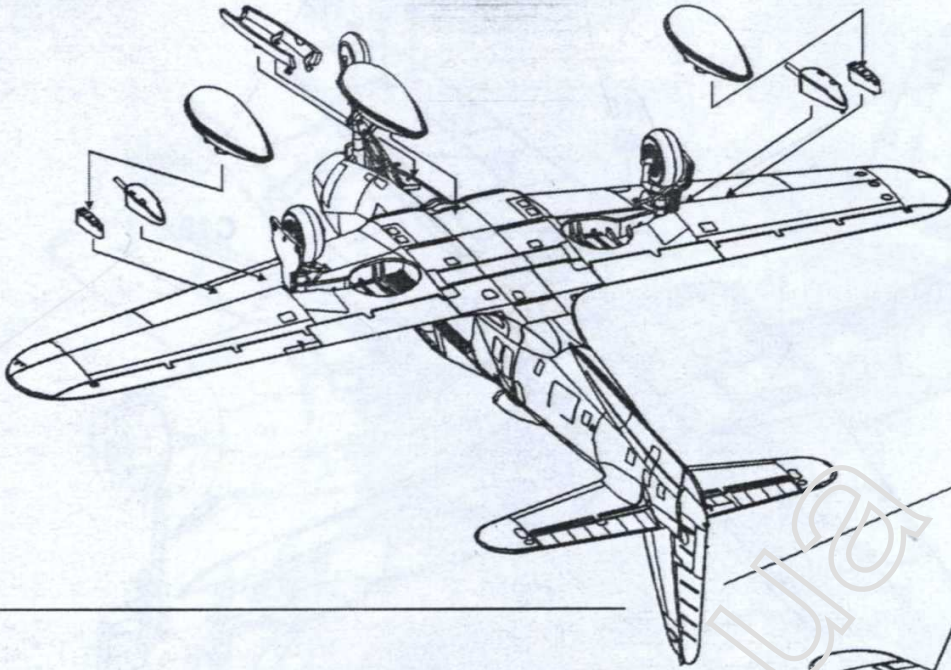

47

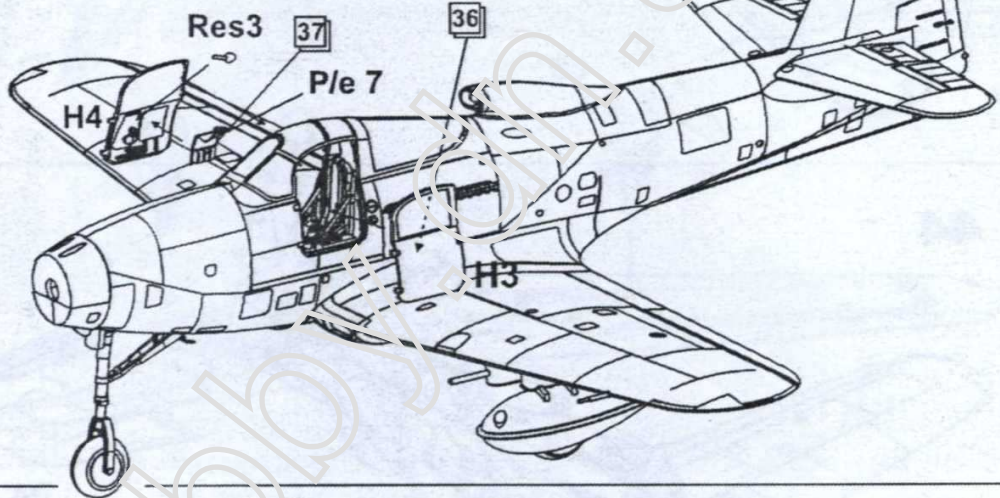

48

