



№ 48-709

Messerschmitt BF.109 G-6 captured, USA

On 8 may 1943 US Army soldiers found fully operational Me-109 G-6 ("white 6" w/nr.16416) on abandoned German scrapyard in Tunisia. It had been abandoned by 4./JG77 staff due to lack of engine fuels and lubricants. When the American maintenance crew had figured out the worth of the captured aircraft they immediately sent the plane to Wright Field research centre in the USA. On 10.08.1944 the Me109 was given nuber EB-102 ("Ewaluation Branch") Until 10.08.44 it was intensively tested - the plane logged 26 hours w/American stars of fuselage and tail...

In May 1943 Me109 G-6 ("yellow 16" of 9./JG 77) captured by the 325 FG USAAF in Mateur, Tunisia. The plane was remembered by the US pilots after curious military action - simulated attack on P-38 LIGHTNING's base (1st FG USAAF). The Me109 had been repainted overall flat black, with a red spinner, rudder, and ailerons. It was also given USAAF markings and named "Hoimann" in honour of Hermann Goring.

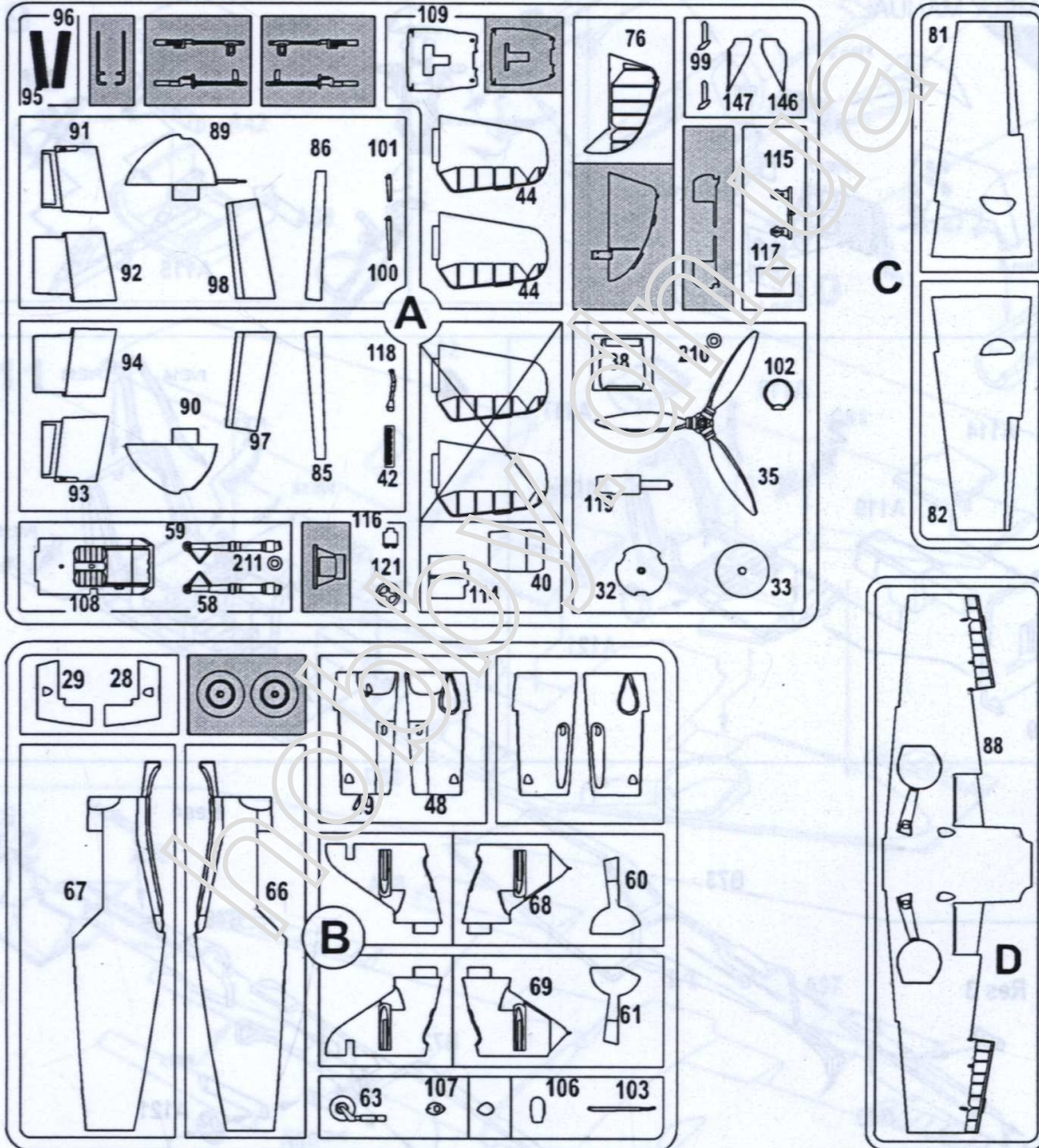

THE CONDITIONAL DENOTATION УСЛОВНЫЕ ОБОЗНАЧЕНИЯ



BE CAREFUL
ОСТОРОЖНО



DON'T CEMENT
НЕ КЛЕИТЬ



REMOVE
РЕЗАТЬ



SYMMETRICAL
СИММЕТРИЧНО



MAKE TWO
УДВОИТЬ



OPTIONAL
НЕОБЯЗАТЕЛЬНО



BEND
СОГНУТЬ



OPEN WHOLE
СВЕРЛИТЬ



CEMENT
КЛЕИТЬ



VARIANTS
ВЫБОР ВАРИАНТА

Resin



1



2 3 4

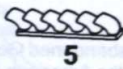

5

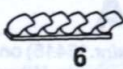

6

Clear



1



2



3

P/E

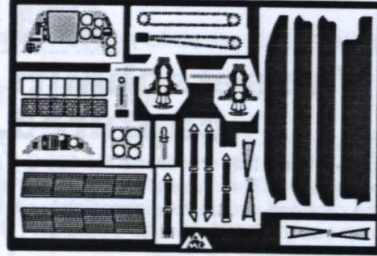

Film



AMG 48703

ASSEMBLY MANUAL

1

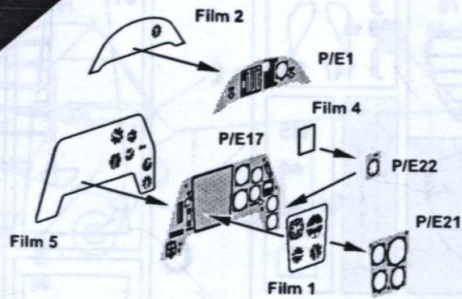

2

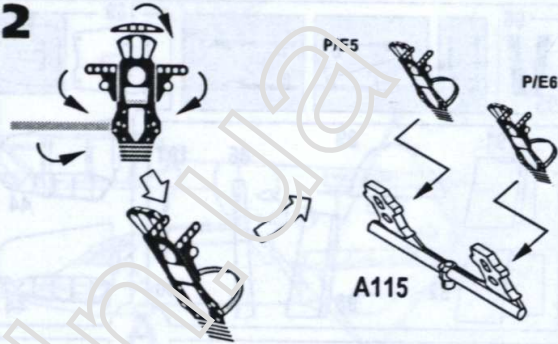

3

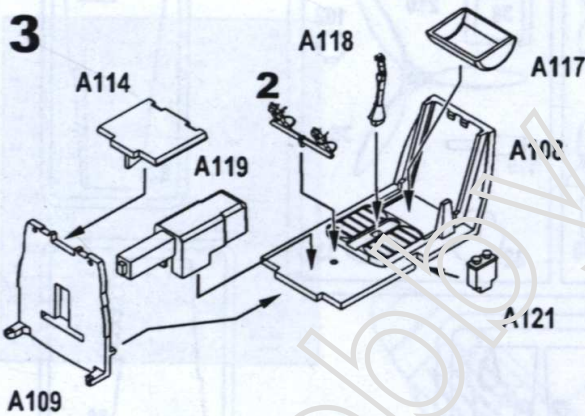

4

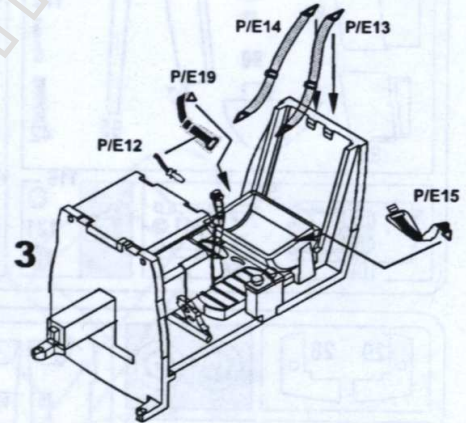

5

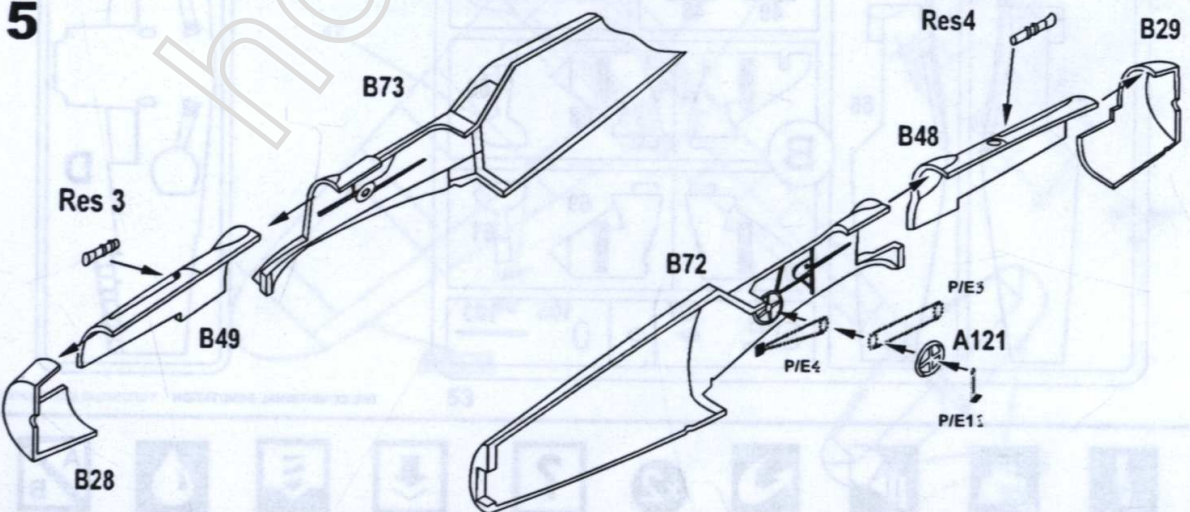

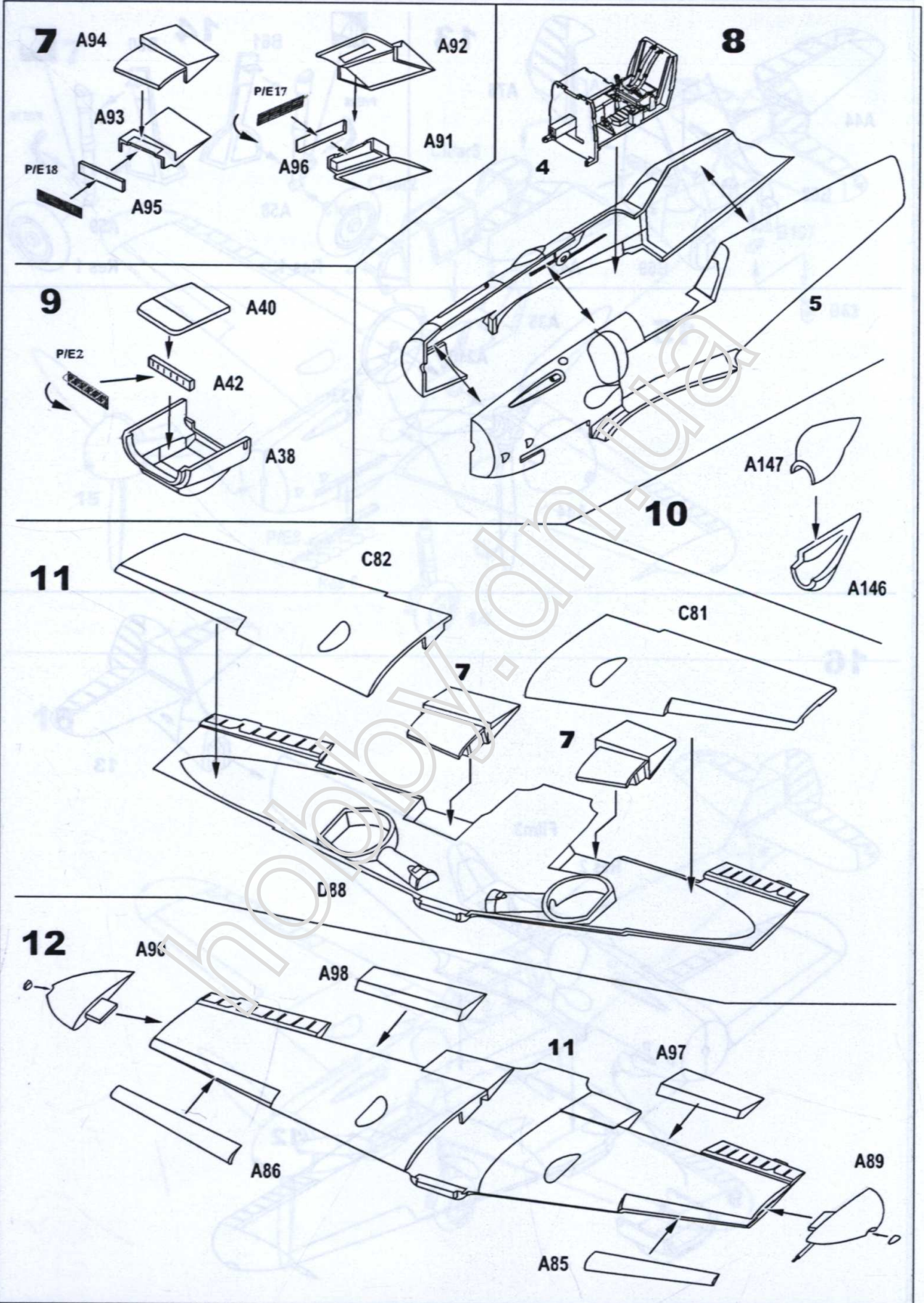

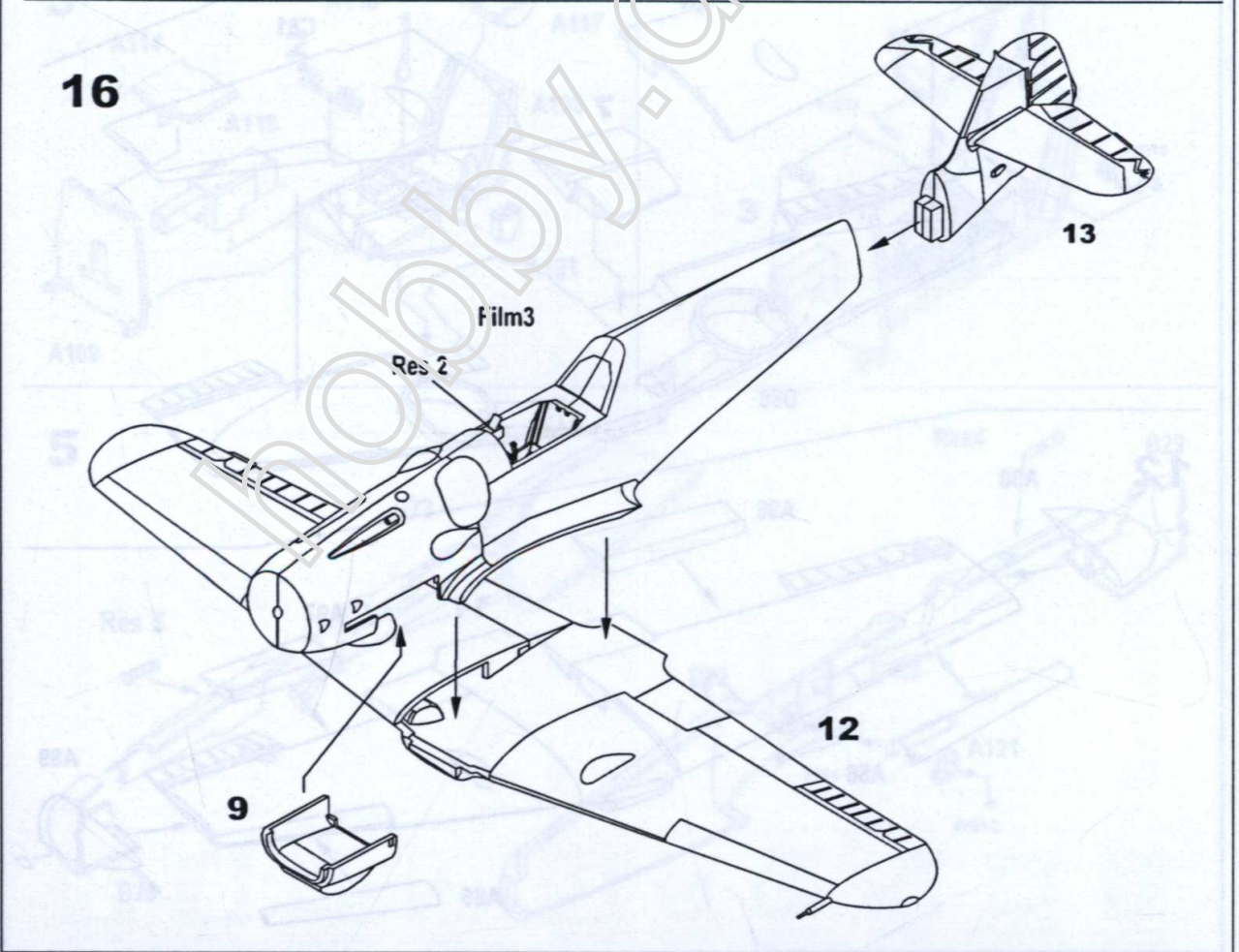
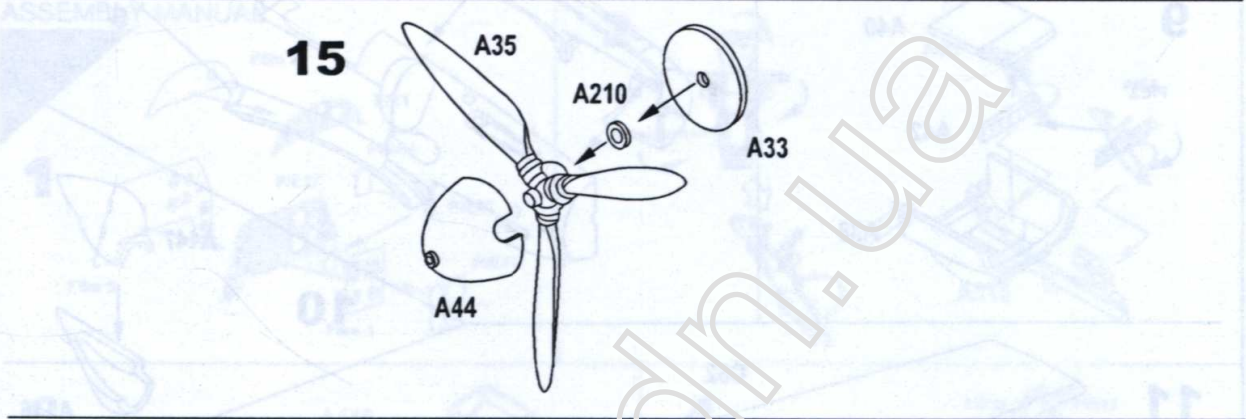
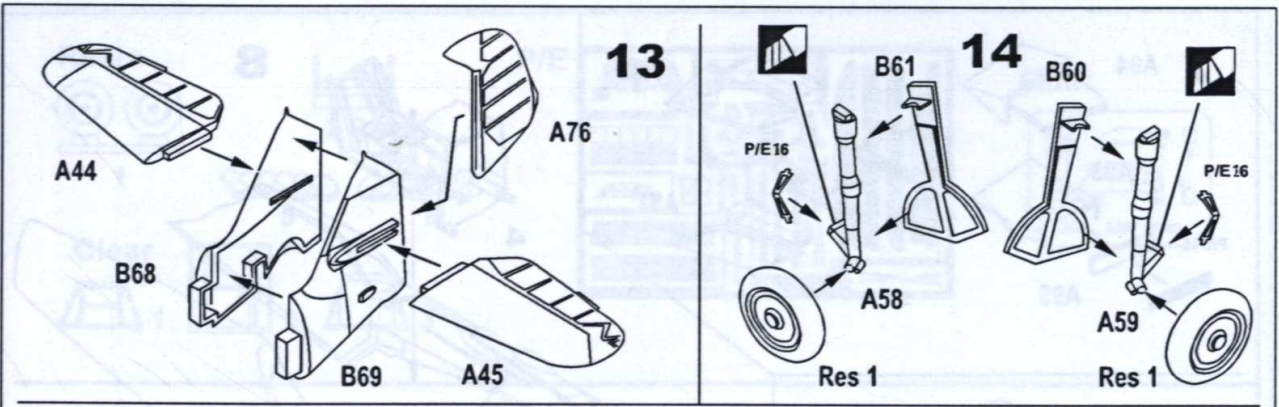

17

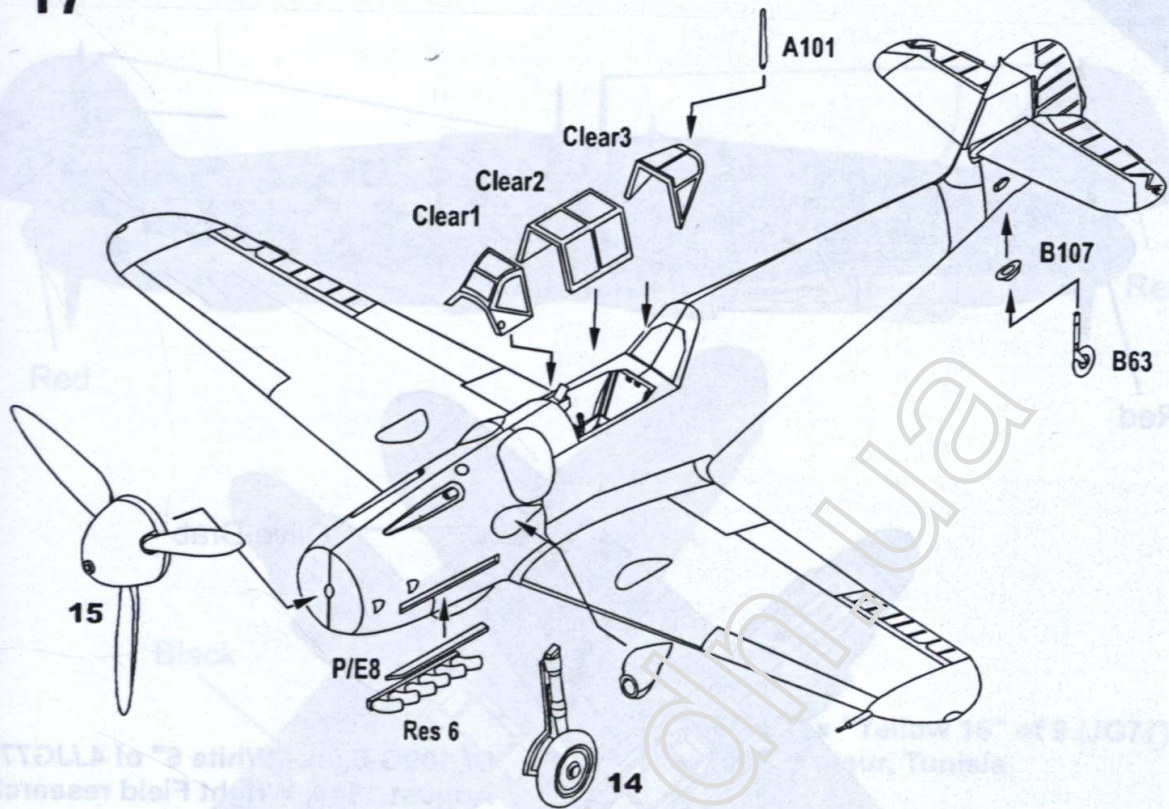

18

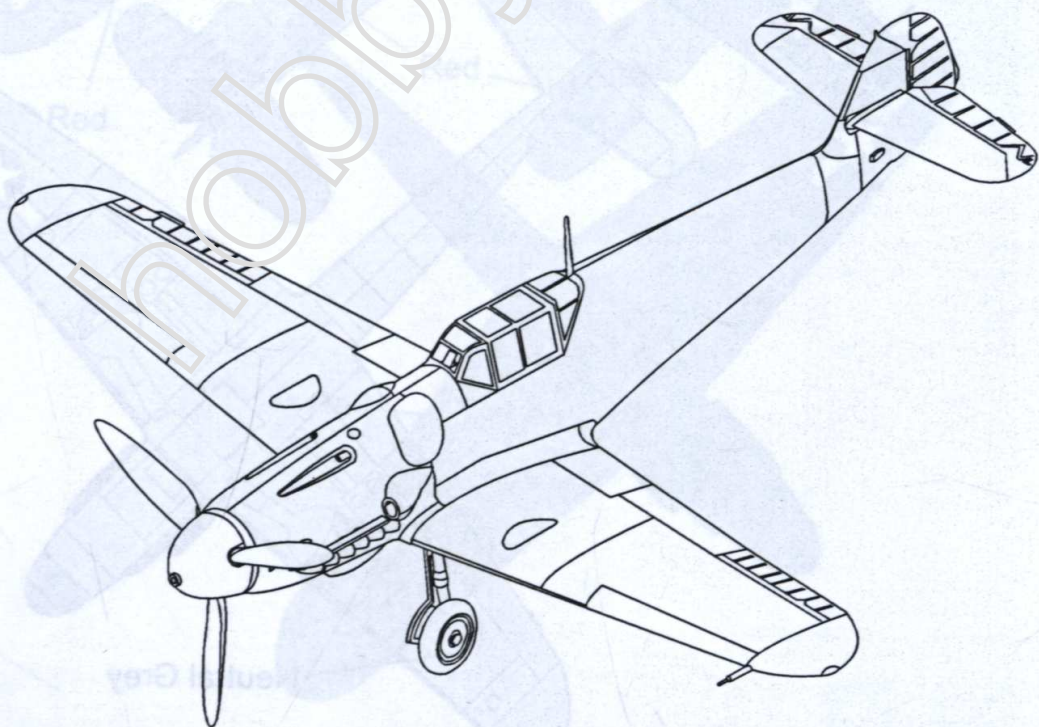

PAINT MANUAL

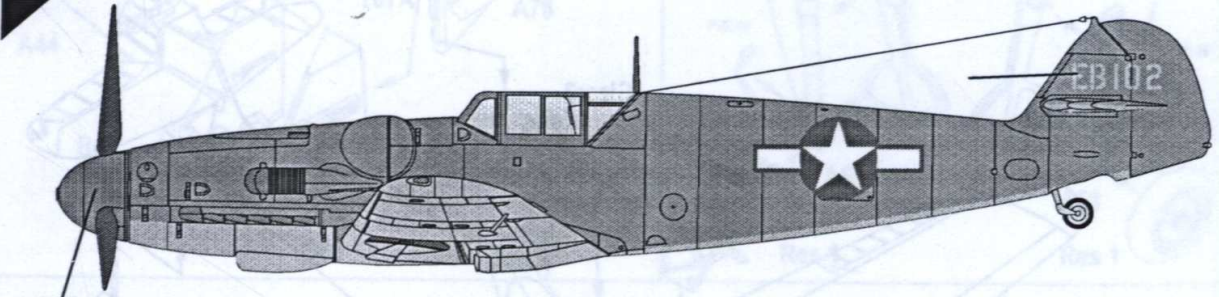

Red

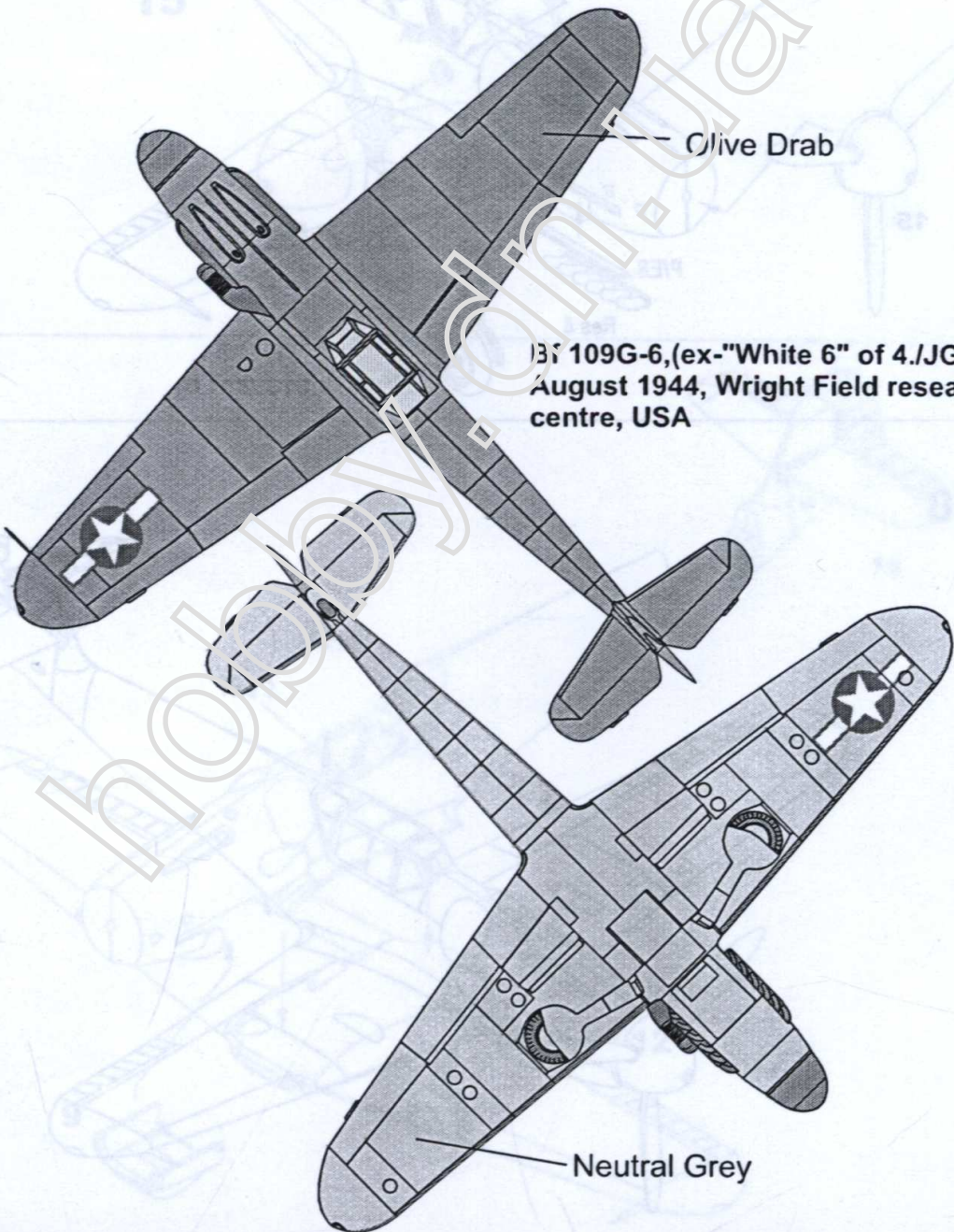

Olive Drab

P-51 109G-6, (ex-"White 6" of 4./JG77)
August 1944, Wright Field research
centre, USA

Neutral Grey

Aviastar Aircraft Co. Ltd. 10000 Airport Blvd. Suite 1000
Van Nuys, CA 91411-3209
Tel: (818) 709-7000 Fax: (818) 709-7001
www.aviastar.com

No 48-709

Messerschmitt Bf 109 G-6

captured USA

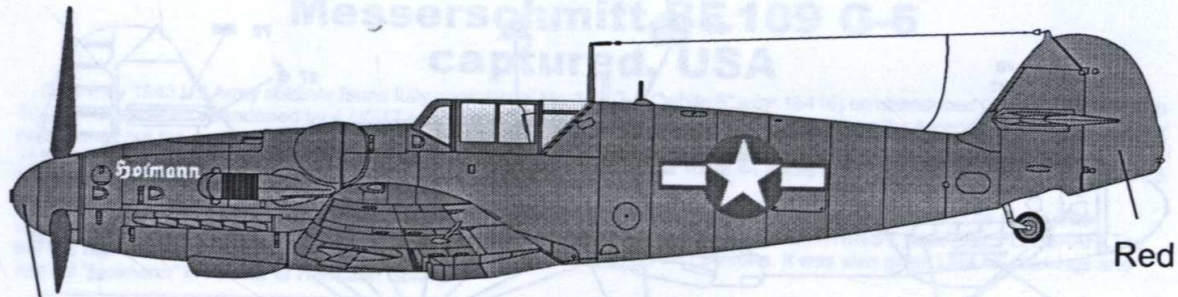

Red

Red

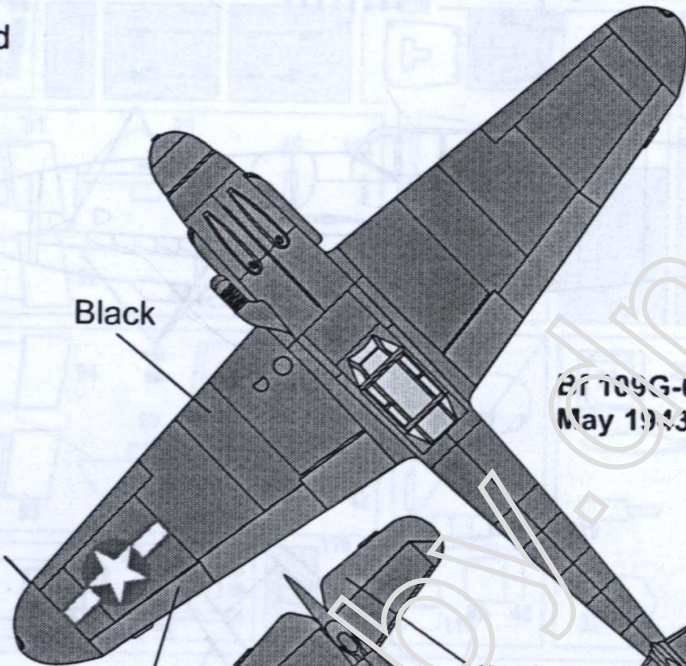

Black

Red

Red

Bf 109G-6 (ex-"Yellow 16" of 9./JG77)
May 1943, Mateur, Tunisia

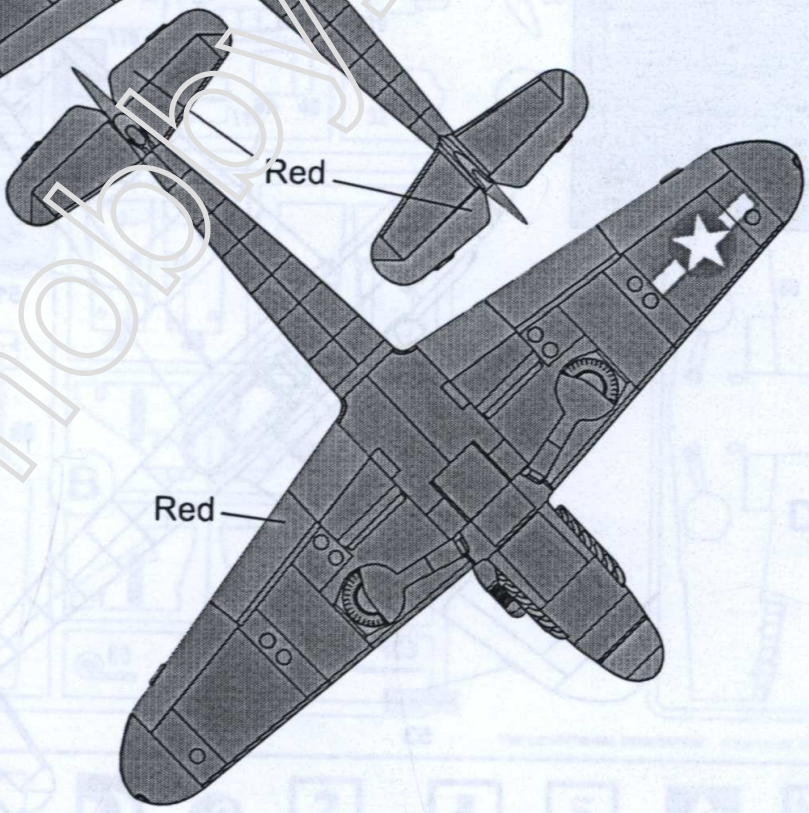

Red

Availability and selection of items designations verify by the photos!

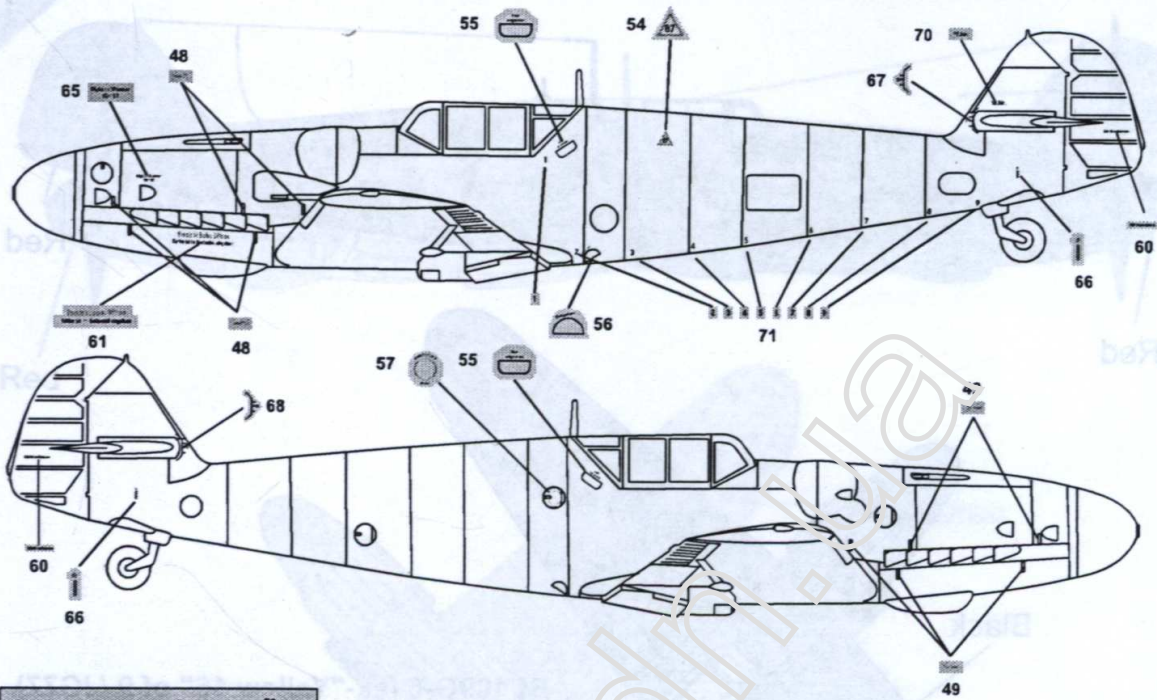

48	58	52
49	51	53
47	55	56
54	57	59
61	62	63
64	65	66
68	70	71

