

# FiSK 199

On the many experiments with the Bf 109 was the attempt to make it carry a 500 kg bomb. The Fieseler did the design work and Skoda built the prototype which was designated FiSk 199.

A Bf 109G, BD+GC, was converted to test the development potential. The Db601 was replaced by a DB605, one R4 drop tank was added beneath each wing, as well as an ETC 500 bomb rack under the fuselage. To clear the large 500kg bomb from the supplementary wheel was jettisoned and went back to earth with a parachute.

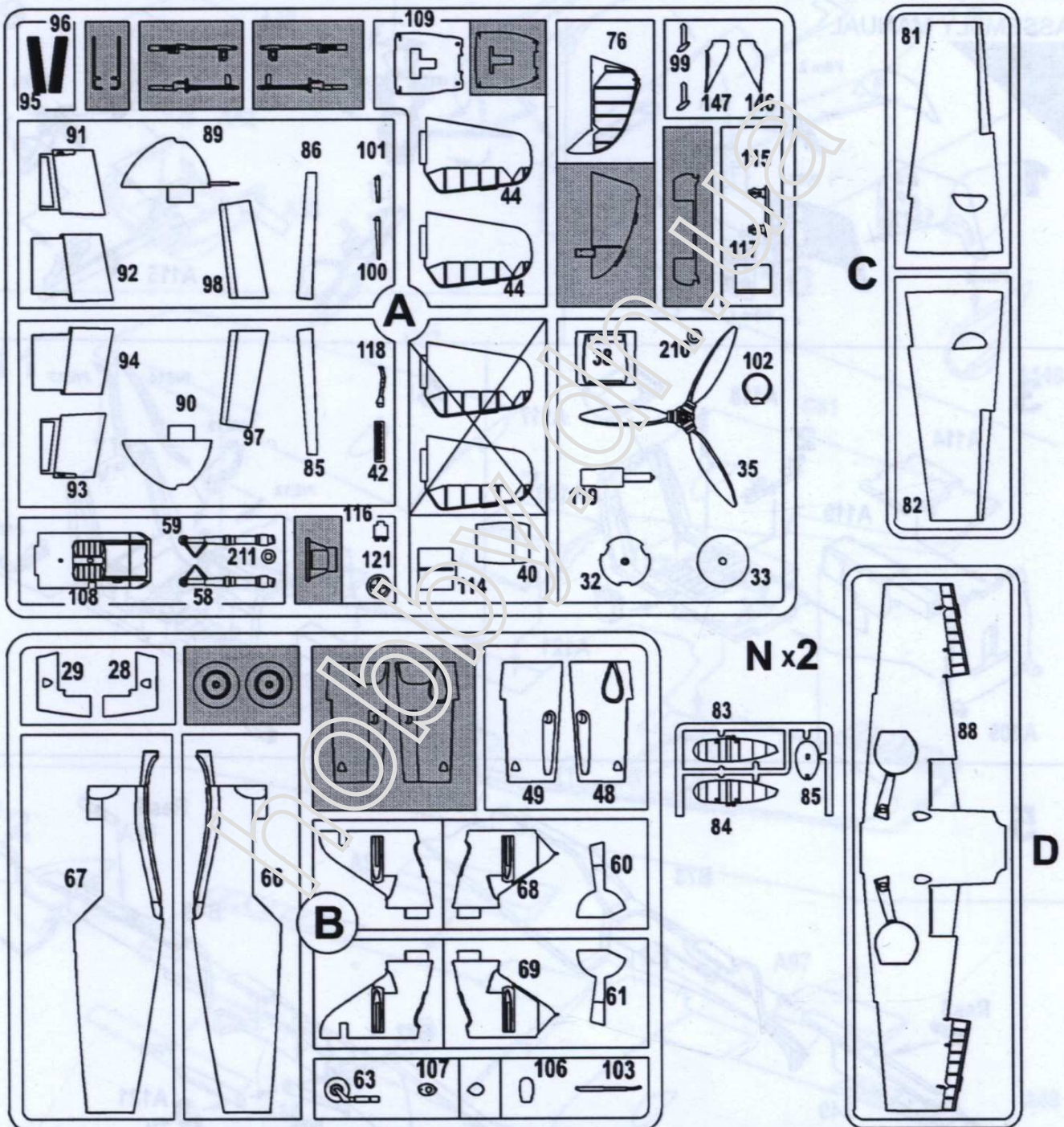

THE CONDITIONAL DENOTATION УСЛОВНЫЕ ОБОЗНАЧЕНИЯ



BE CAREFUL  
ОСТОРОЖНО



DON'T CEMENT  
НЕ КЛЕИТЬ



REMOVE  
РЕЗАТЬ



SYMMETRICAL  
СИММЕТРИЧНО



MAKE TWO  
УДВОИТЬ



OPTIONAL  
НЕОБЯЗАТЕЛЬНО



BEND  
СОГНУТЬ



OPEN WHOLE  
СВЕРЛИТЬ



CEMENT  
КЛЕИТЬ



VARIANTS  
ВЫБОР ВАРИАНТА

Resin

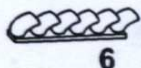
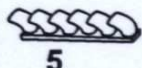
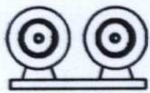

P/E

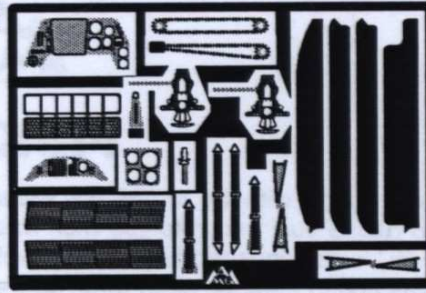

Film

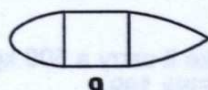

Clear

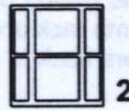

Wire ——— x2

ASSEMBLY MANUAL

1

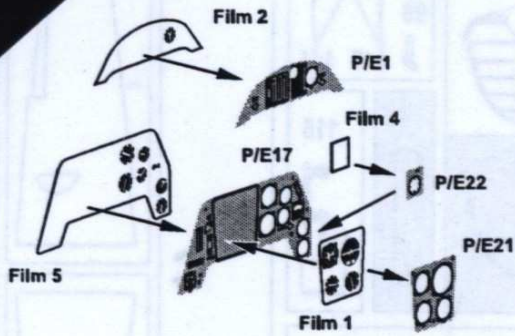

2

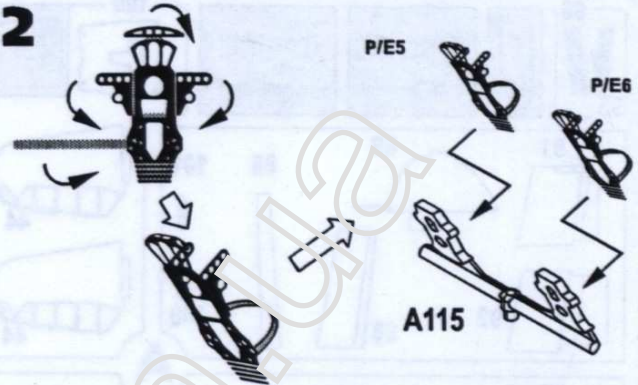

3

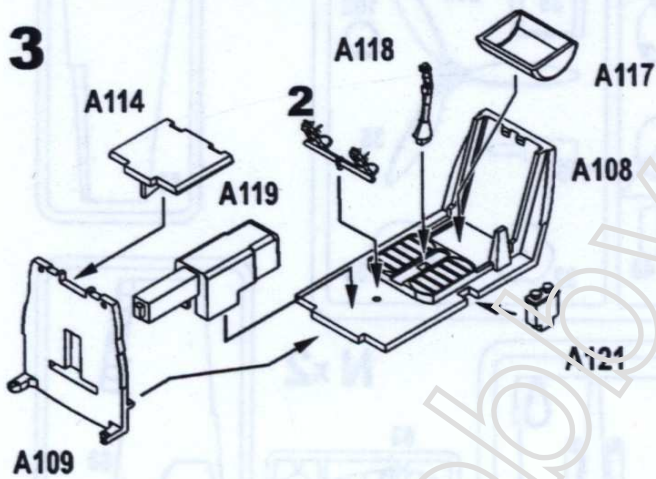

4

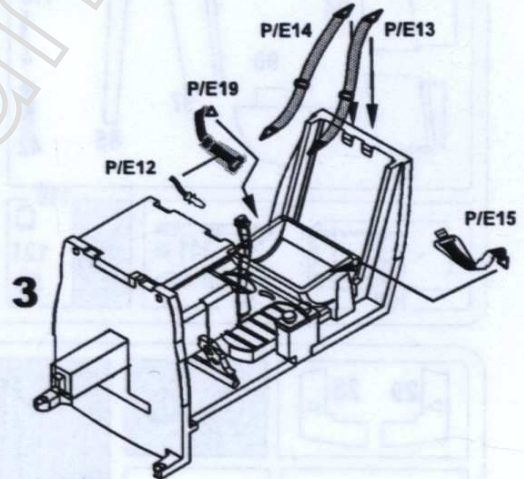

5

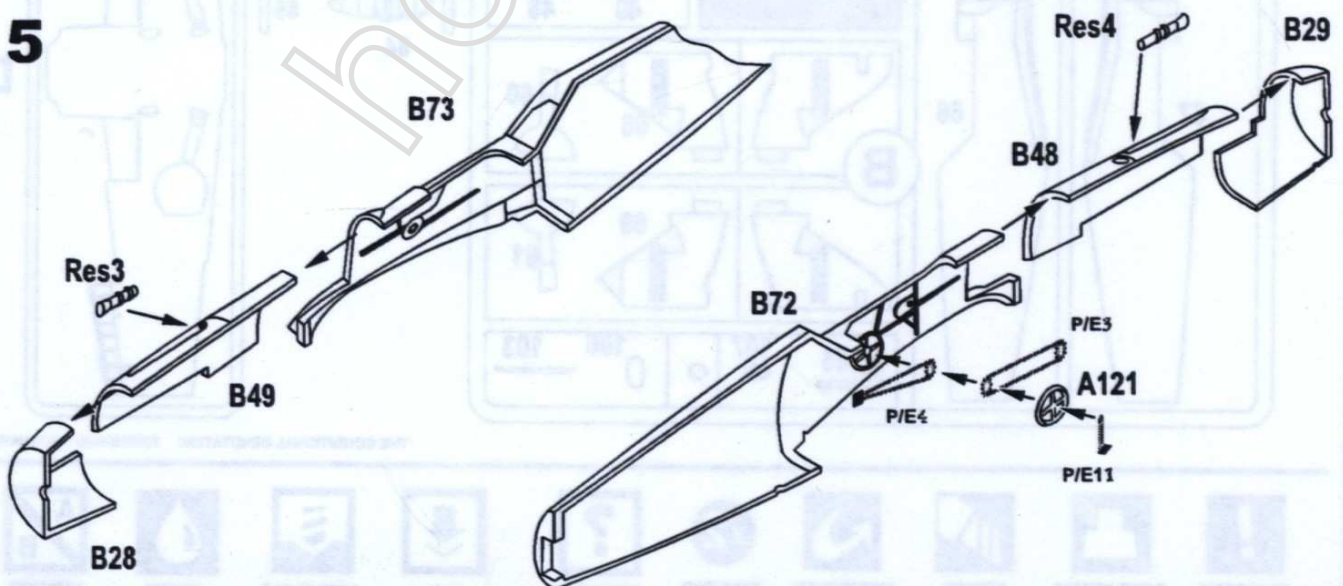

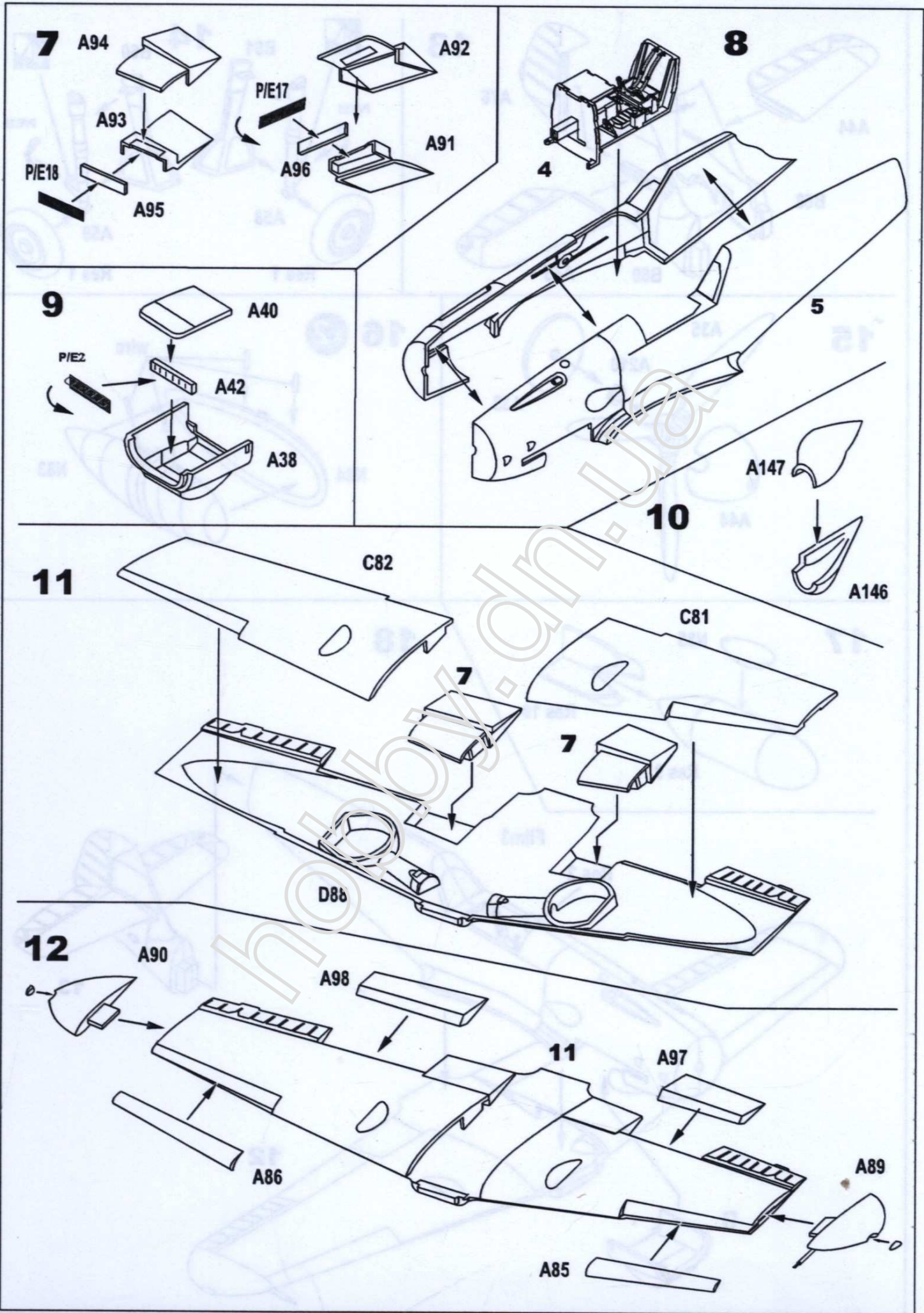

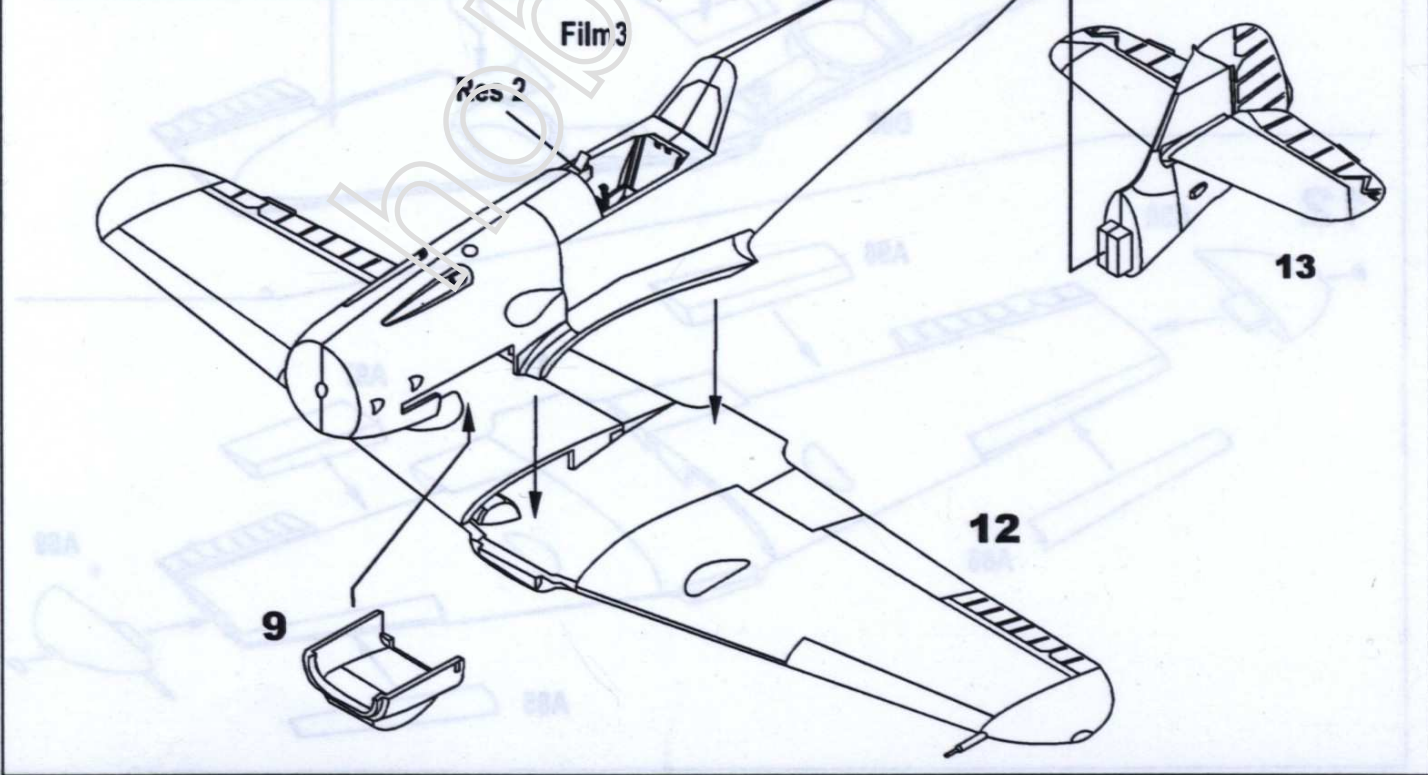
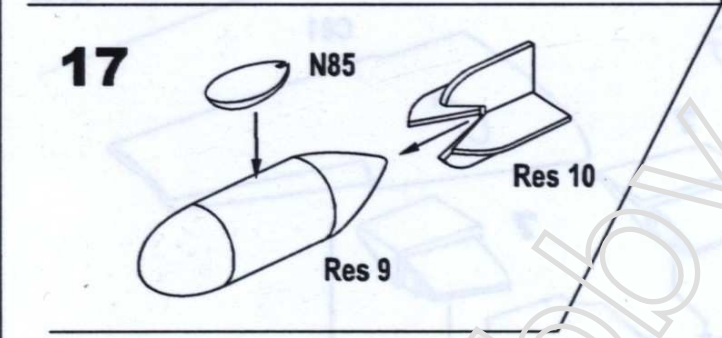
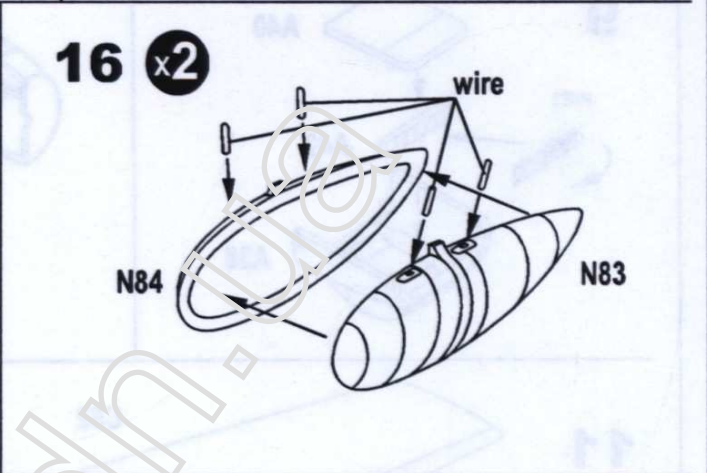
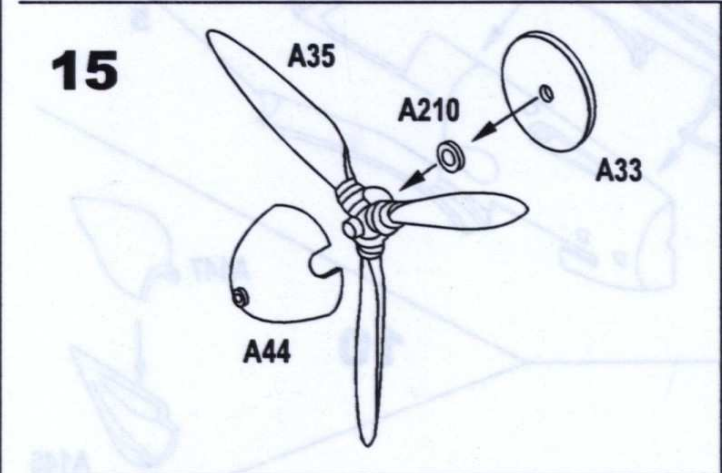
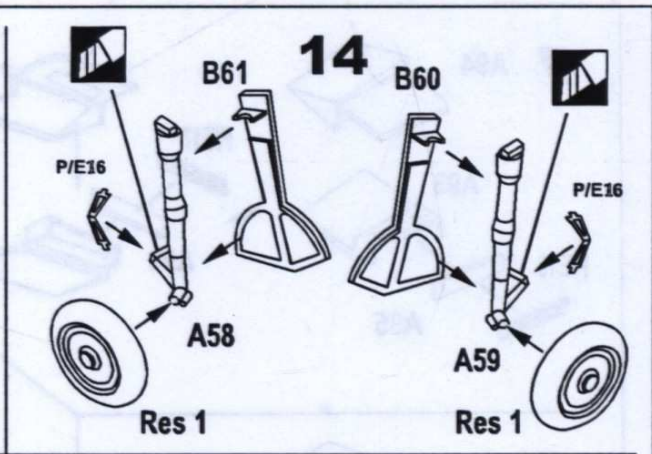
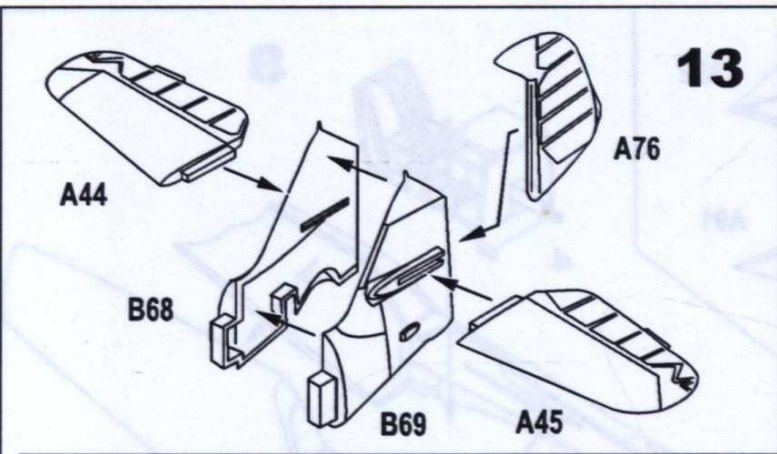

19

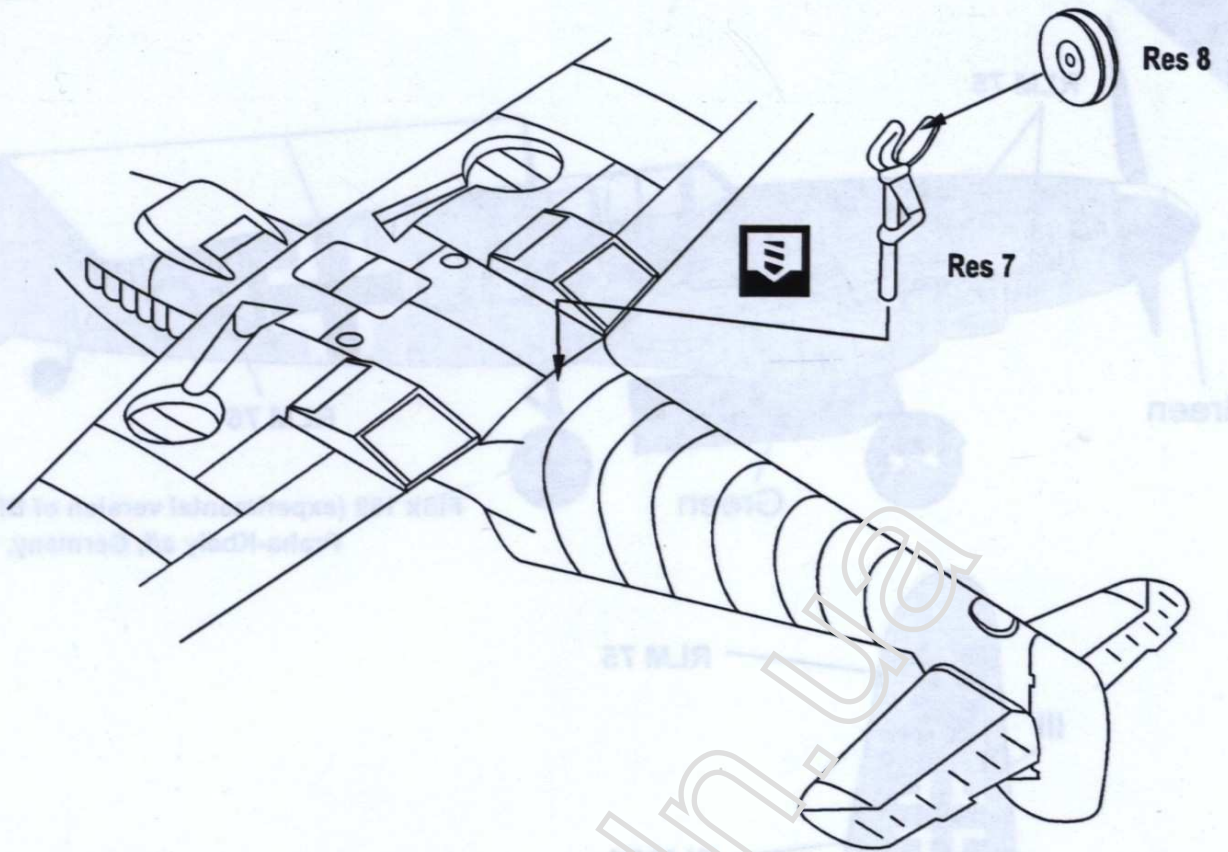

20

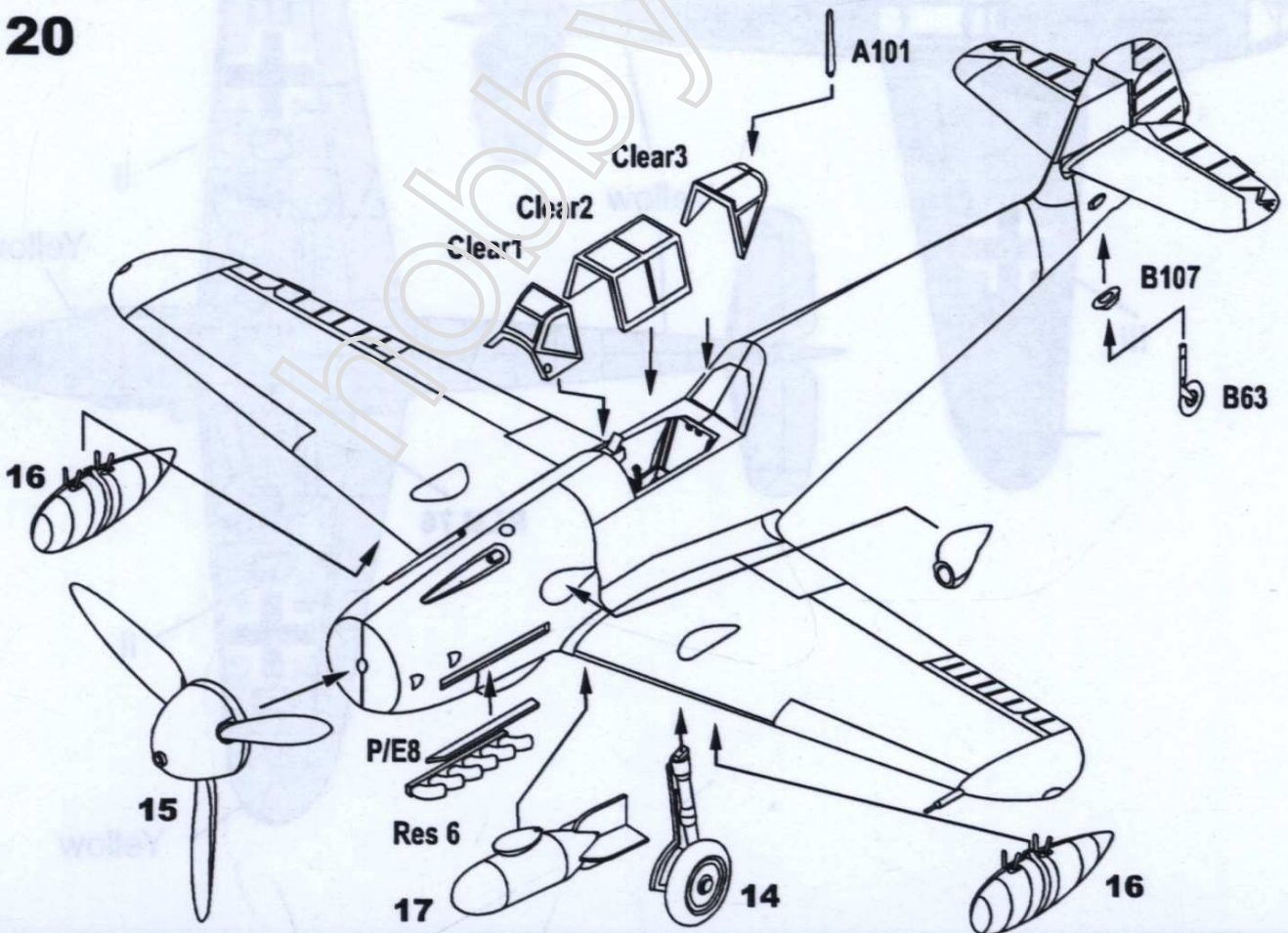

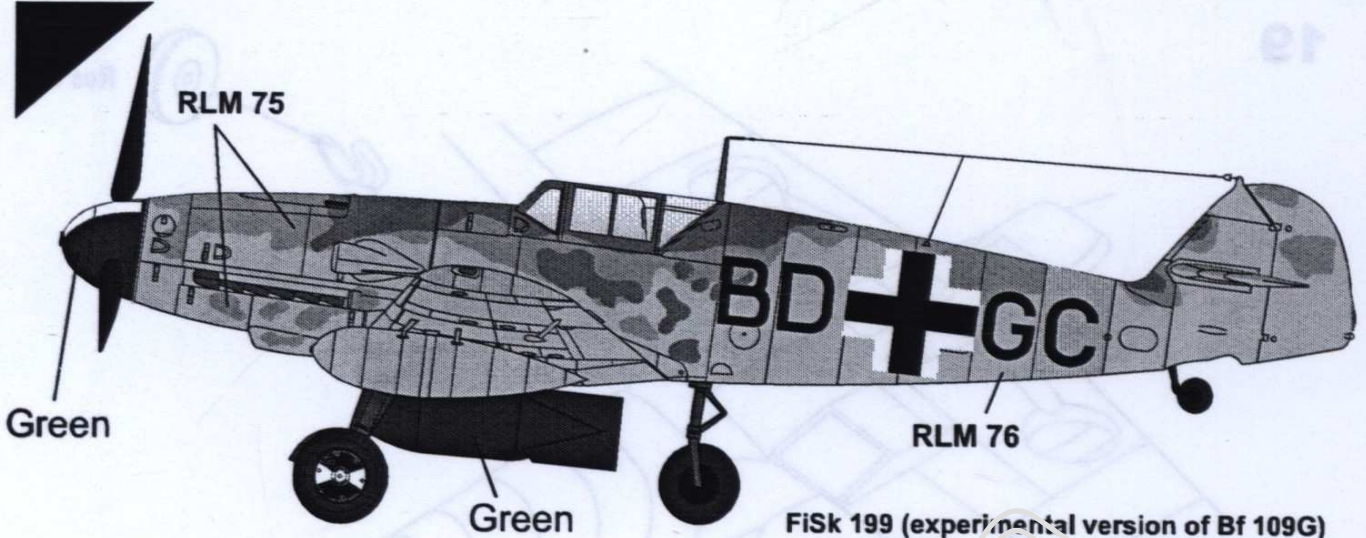

FiSk 199 (experimental version of Bf 109G)  
Prahú-Kbelý air, Germany, 1942

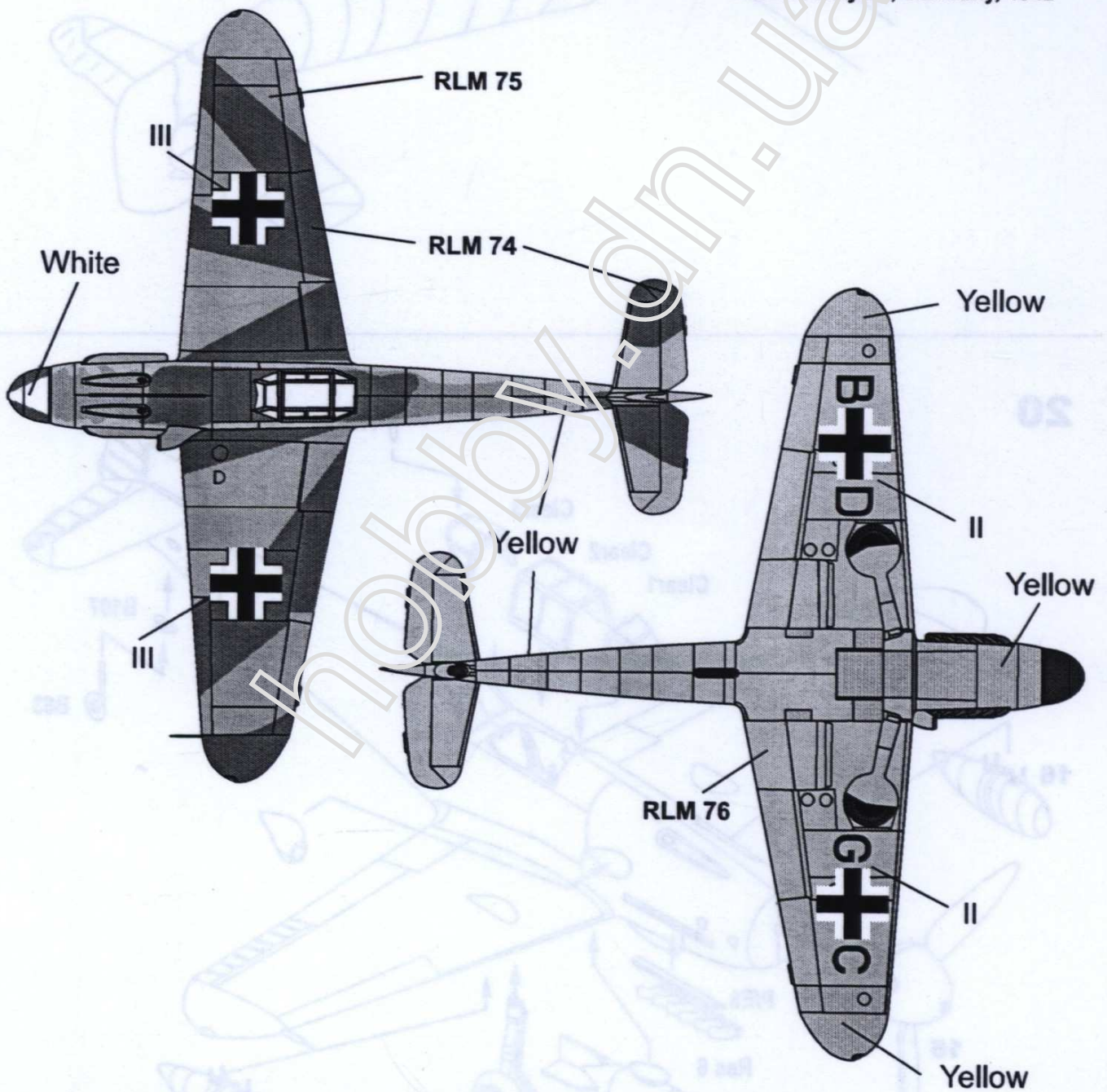

Availability and selection of items designations verify by the photos!

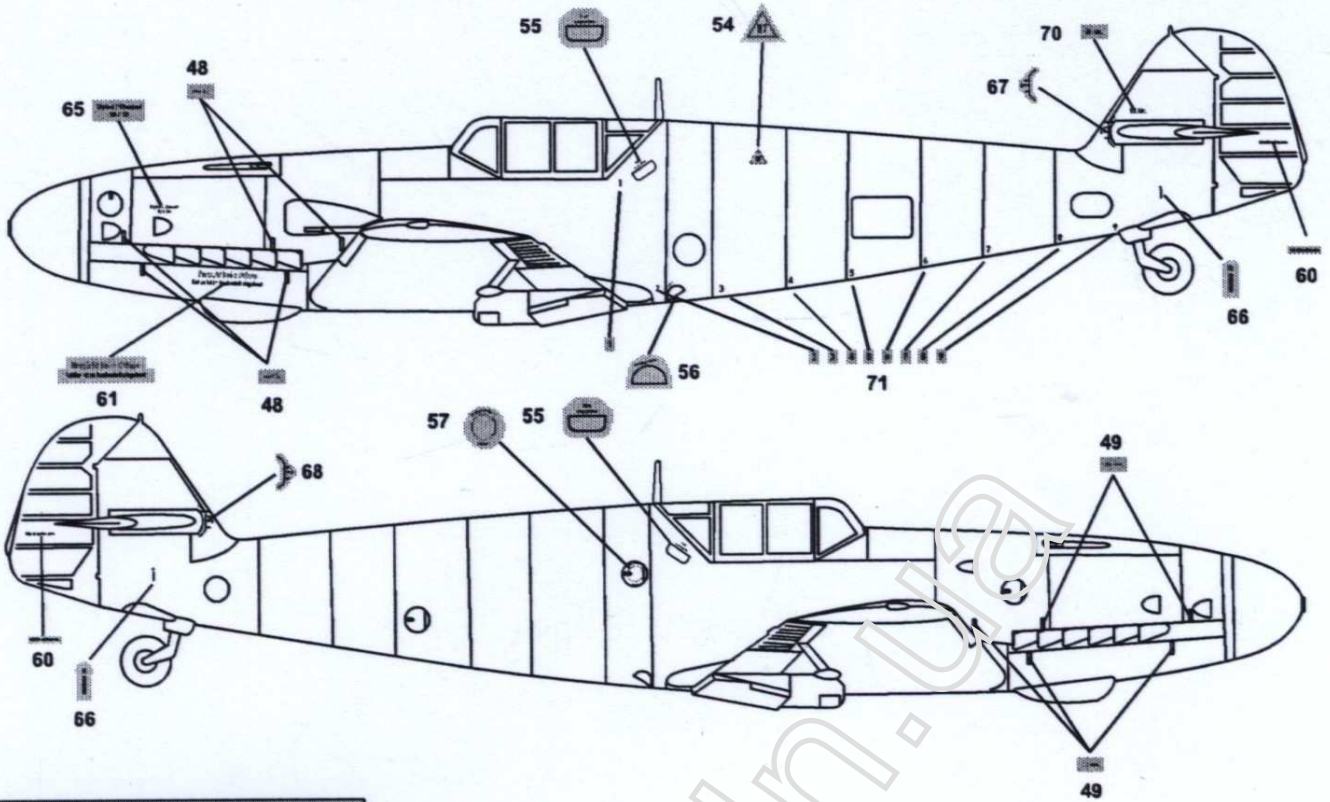

48	50	52
49	51	53
47	54	55
54	56	57
57	58	59
58	59	60
61	62	63
64	65	66
66	67	68
68	69	70
70	71	72

48 Cockpit  
 49 Cockpit  
 50 Cockpit  
 51 Cockpit  
 52 Cockpit  
 53 Cockpit  
 54 Cockpit  
 55 Cockpit  
 56 Cockpit  
 57 Cockpit  
 58 Cockpit  
 59 Cockpit  
 60 Cockpit  
 61 Cockpit  
 62 Cockpit  
 63 Cockpit  
 64 Cockpit  
 65 Cockpit  
 66 Cockpit  
 67 Cockpit  
 68 Cockpit  
 69 Cockpit  
 70 Cockpit  
 71 Cockpit  
 72 Cockpit

AMC  
 BI-1095  
 made

