



Bell P-63C Kingcobra French Air Force

Late in WW2, a contract was signed with the Free French AF for 300 (real supplied 250) P-63c Kingcobras. During the summer of 1945, Kingcobra detachment of the group I/5 "Vendee" was briefly assigned to the French occupation zone in Germany. Most remained in France's nN.African possessions.

By the end of 1947, six French AF groups were operating Kingcobras - I/5 "Vendee" I/9 "Limosin", II/5 "Ile-de-France", II/6 "N.Niemen", II/9 "Auvergne" and III/6 "Roussillon".

As France's problems in it's Indochina colonies picked up in 1946 and 1947 more air power was requested there to fight the communist insurgency. The first Kingcobras arrived in French Indocina in april 1949. A total of five different groups operated in Indochina, rarely all at the same time however.

As the Viet Minh had no aircraft, French P-63s were used exclusively for ground attack missions, either with ww2 - surplus 250lbs bombs or (more effectively) finless napalm bombs. In 1949 Viet Minh had begun to receive 12,7mm DShK and 37mm AA guns from China and the USSR. French Kingcobra losses in Indochina were high - with 30 planes being lost between 1949-51.

The final French combat missions in Kingcobras were flown during the last week of April 1951. By September 1951, there were no P-63 inventory in Indochina...

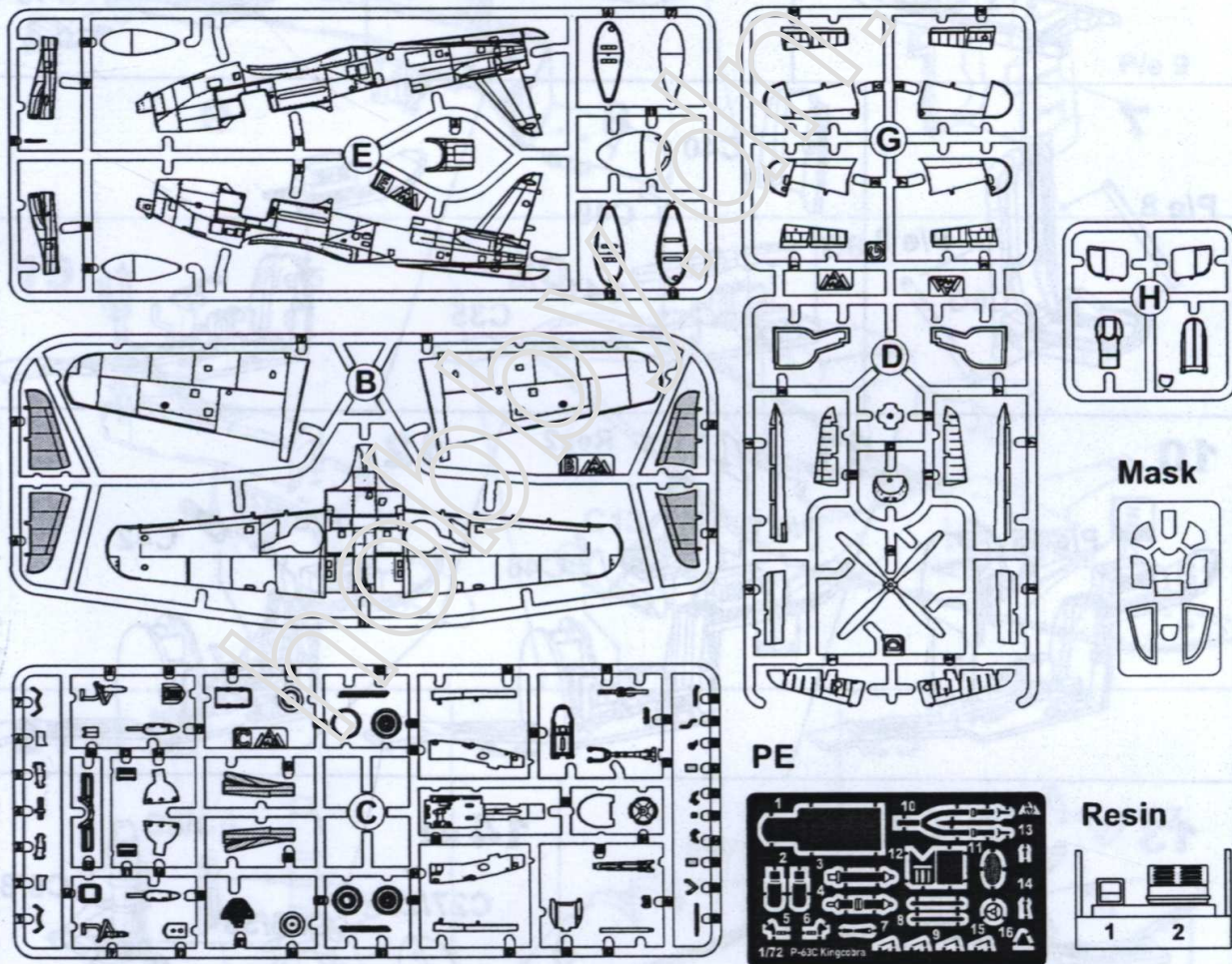

BE CAREFUL
ОСТОРОЖНО



DON'T CEMENT
НЕ КЛЕИТЬ



REMOVE
РЕЗАТЬ



SYMMETRICAL
СИММЕТРИЧНО



MAKE TWO
УДВОИТЬ



OPTIONAL
НЕОБЯЗАТЕЛЬНО



BEND
СОГНУТЬ



OPEN WHOLE
СВЕРЛИТЬ



CEMENT
КЛЕИТЬ



VARIANTS
ВЫБОР ВАРИАНТА

ASSEMBLY MANUAL

1 x2



2

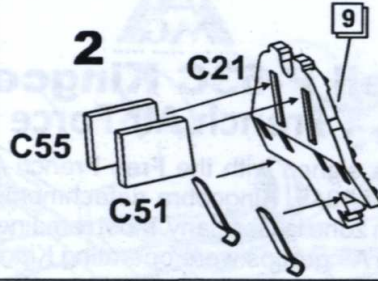

3

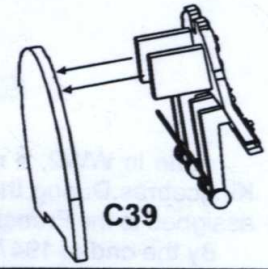

4

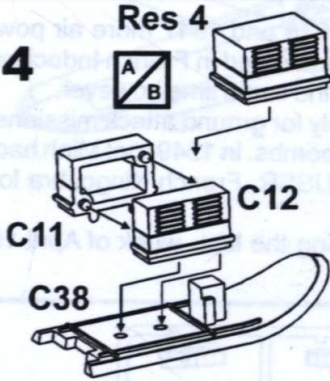

5

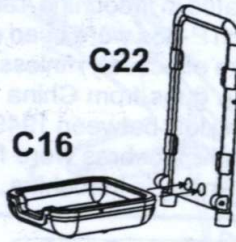

6

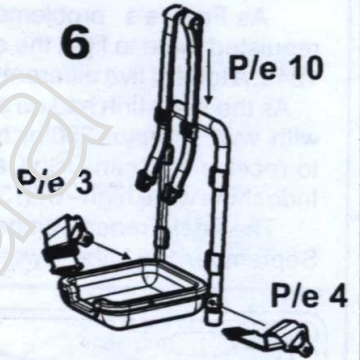

7

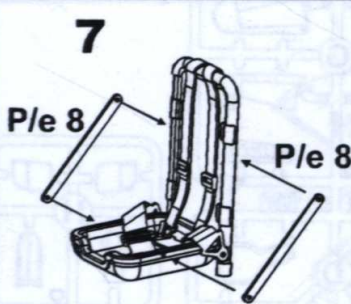

8

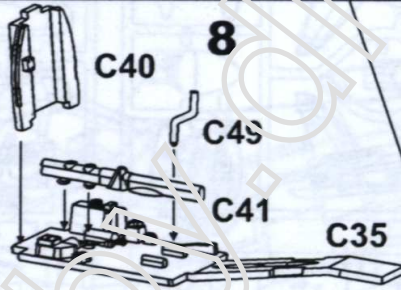

9

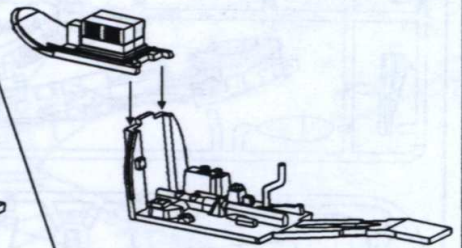

10

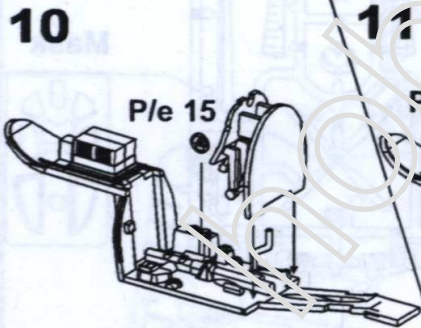

11

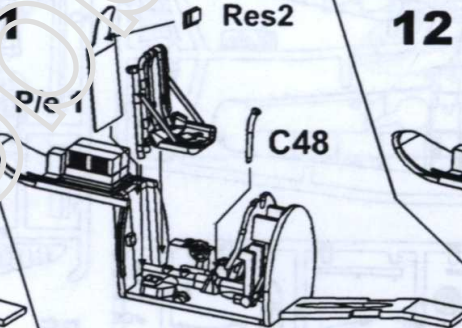

12

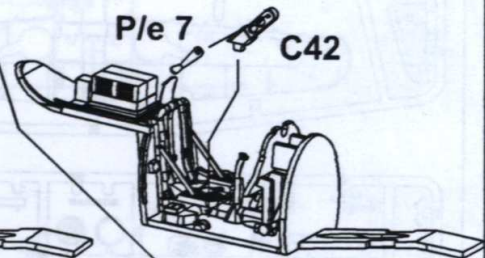

13

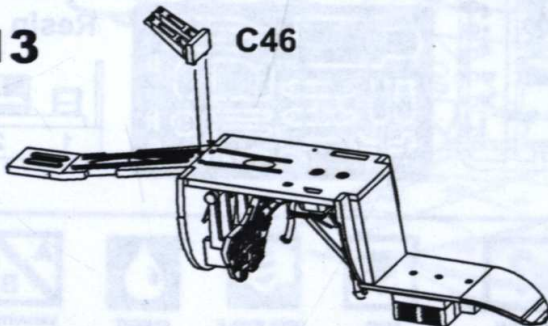

14 x2

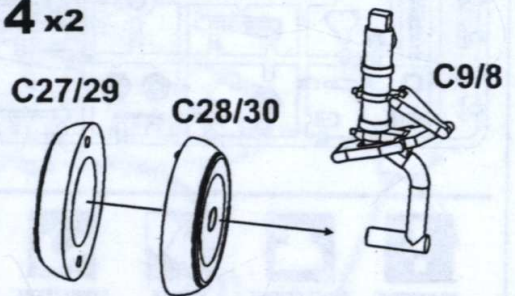

15

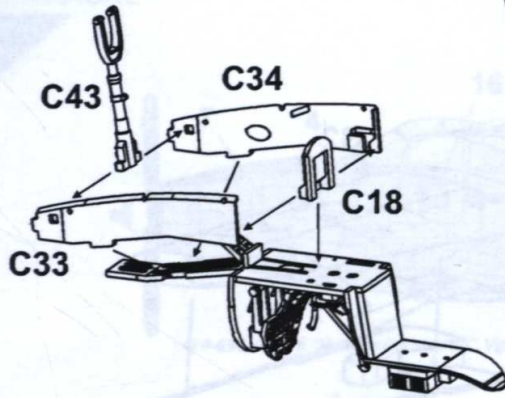

16

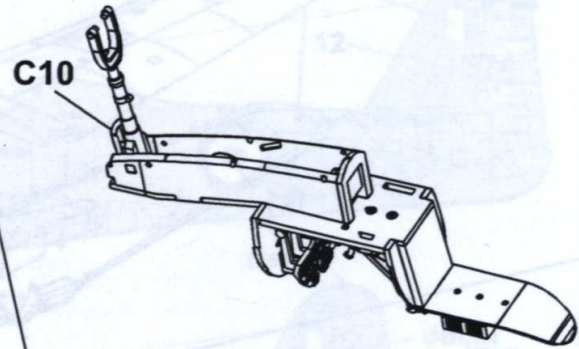

17

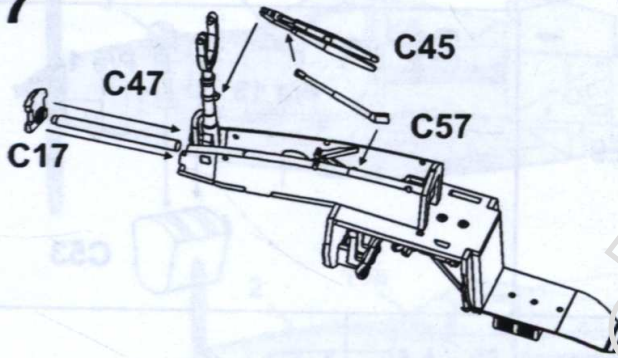

18

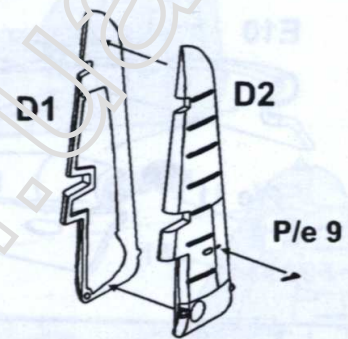

19

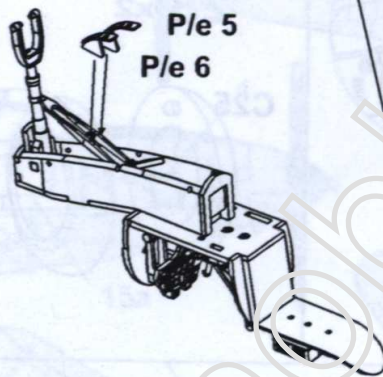

20

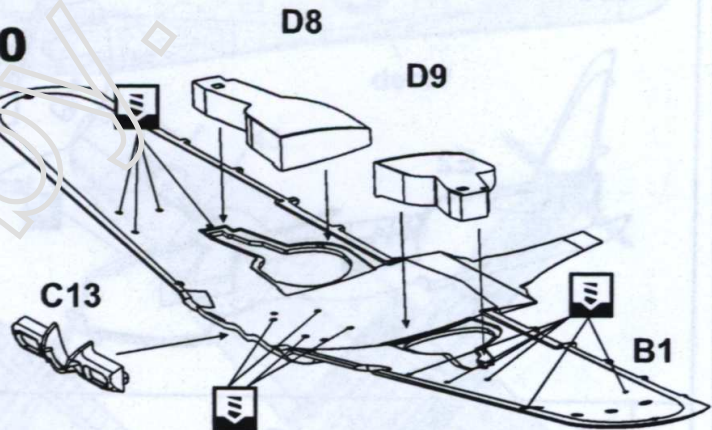

21 x2

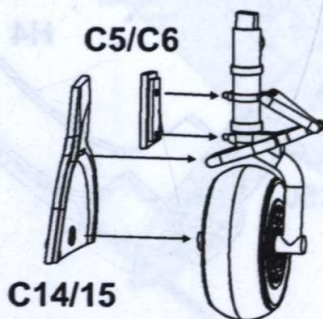

22 x2

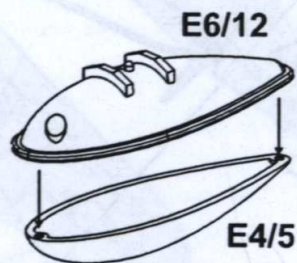

23

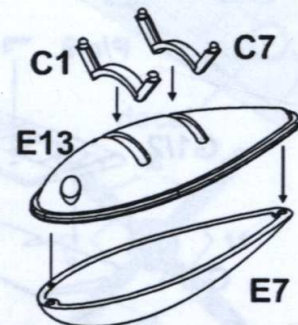

24

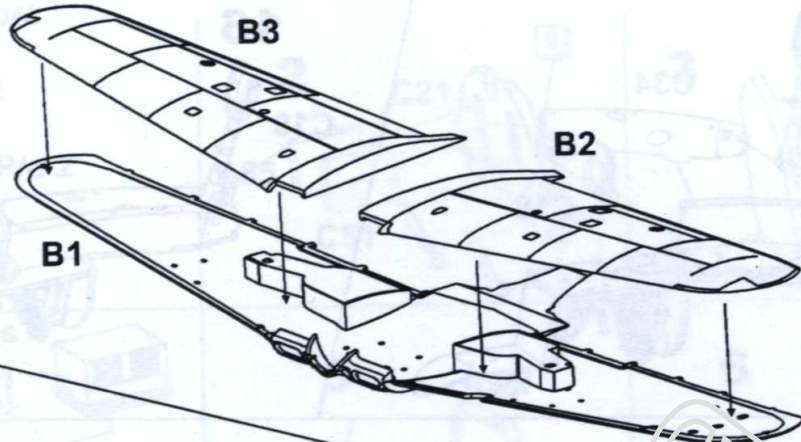

25

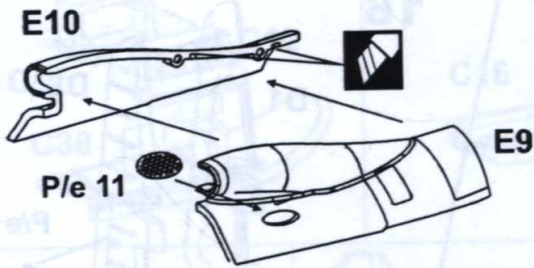

26 x2

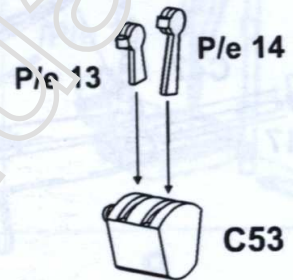

27

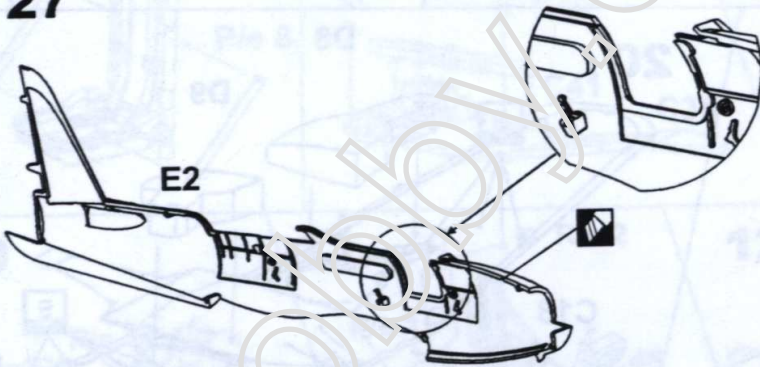

28 x2

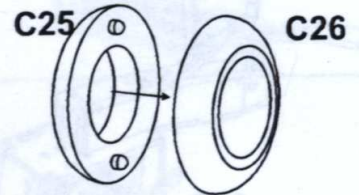

29

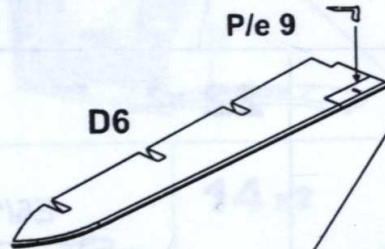

30 x2

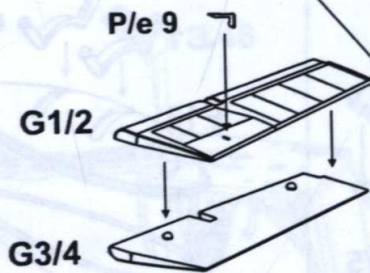

31



32

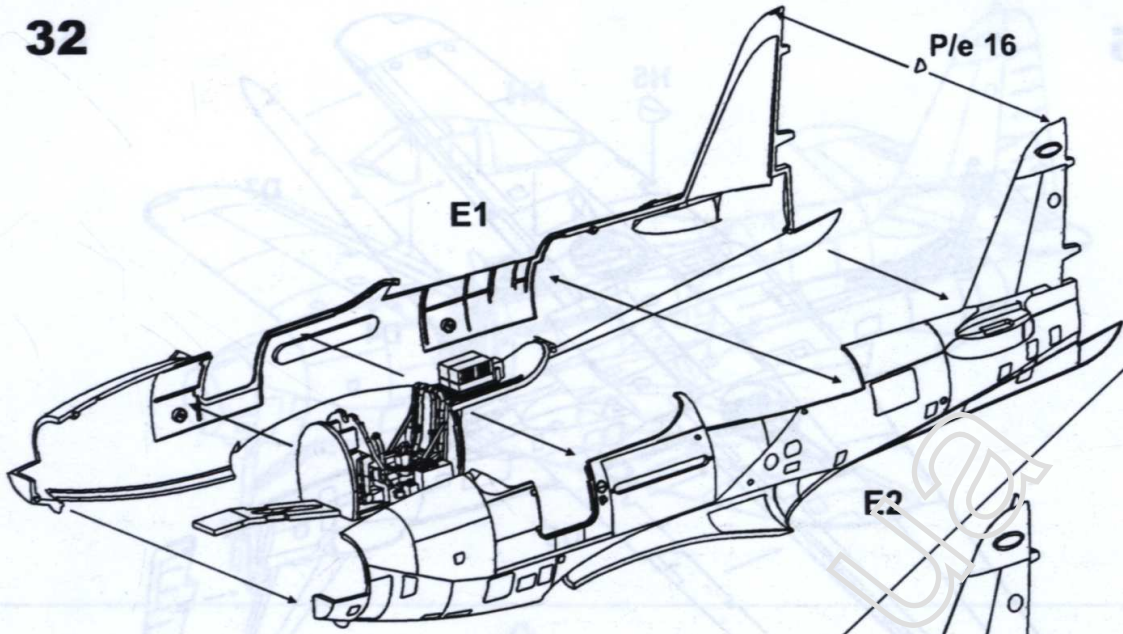

33

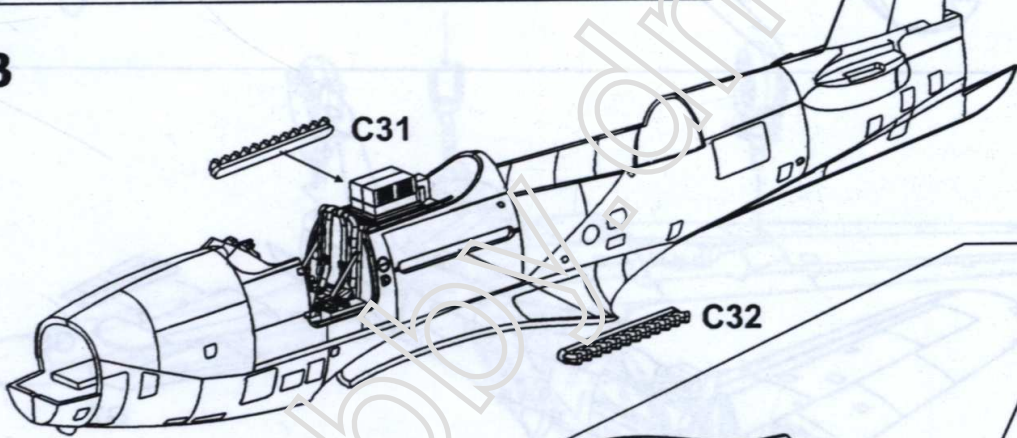

34

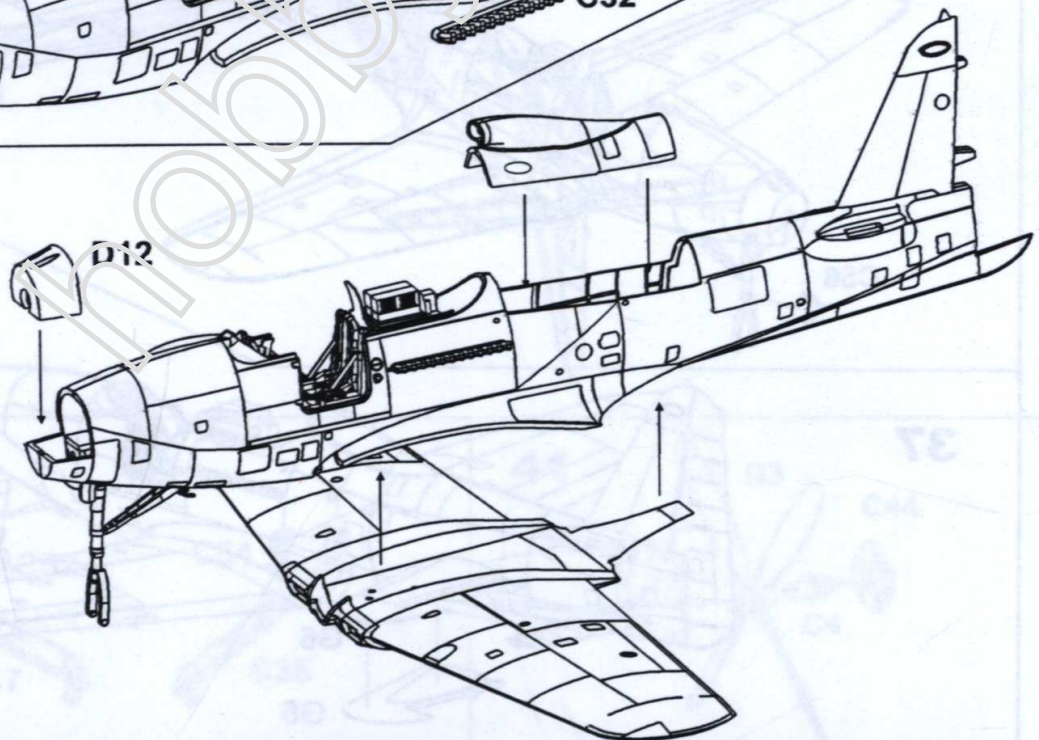

35

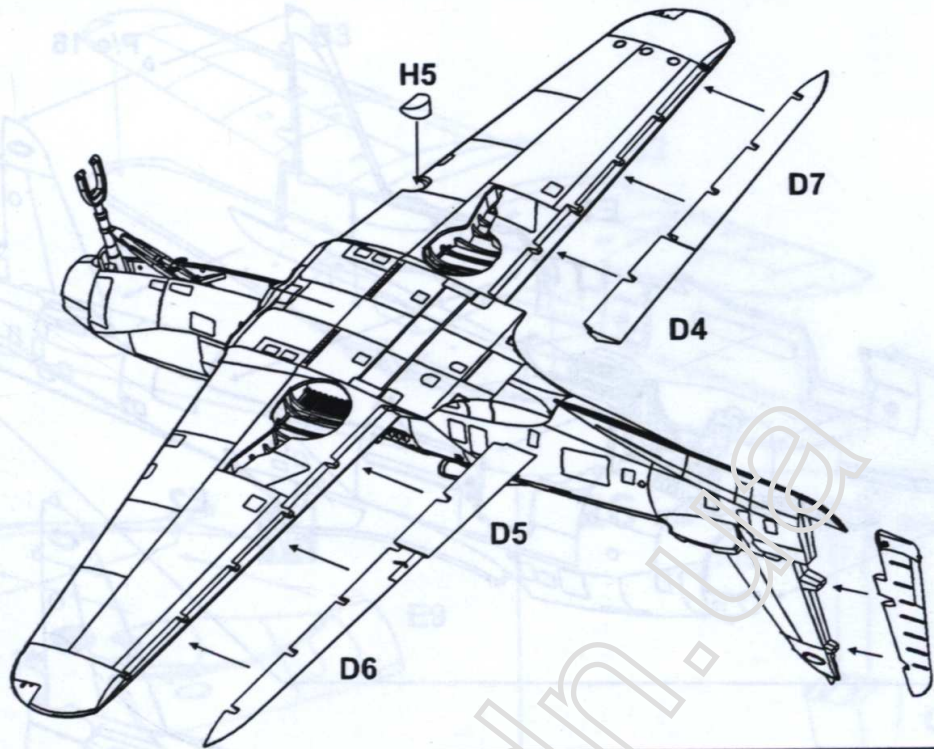

36

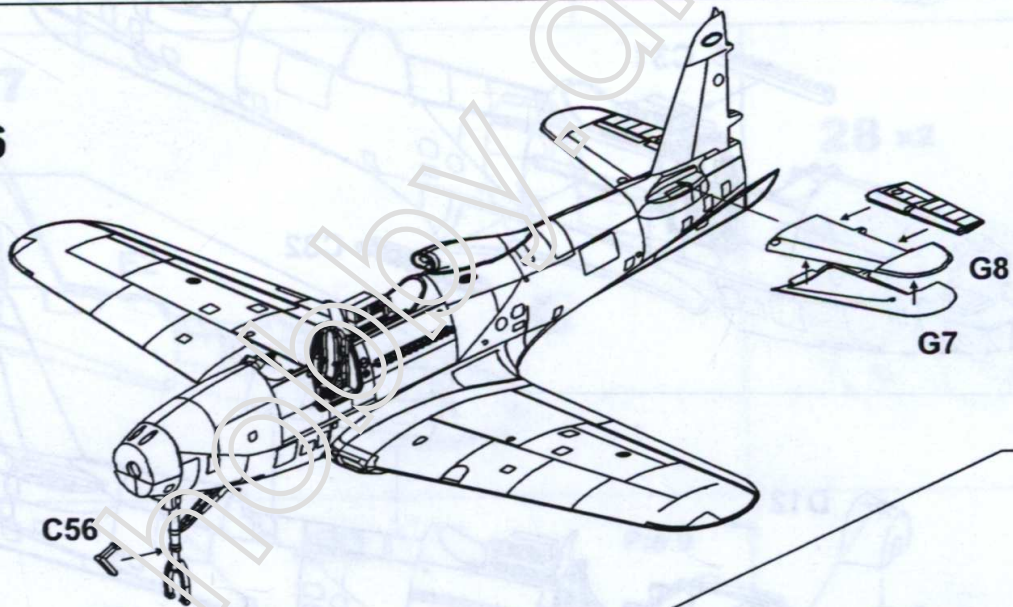

37

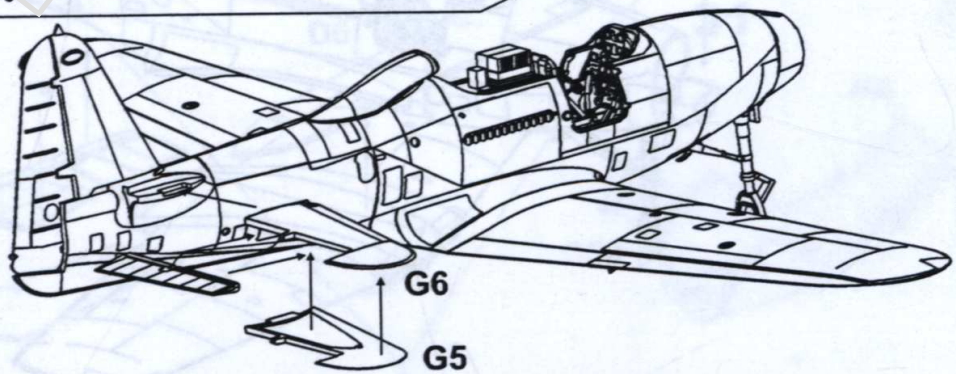

38

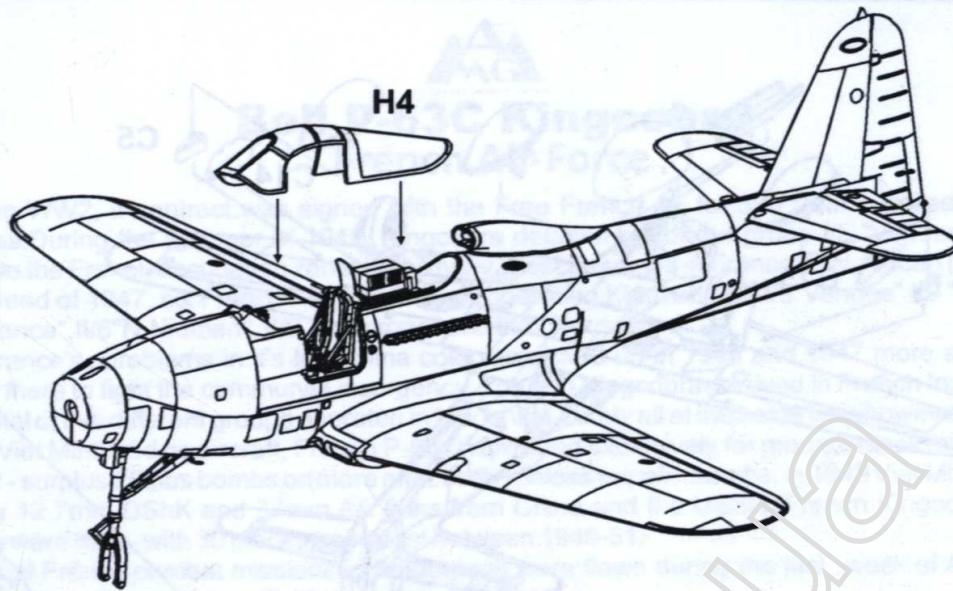

39

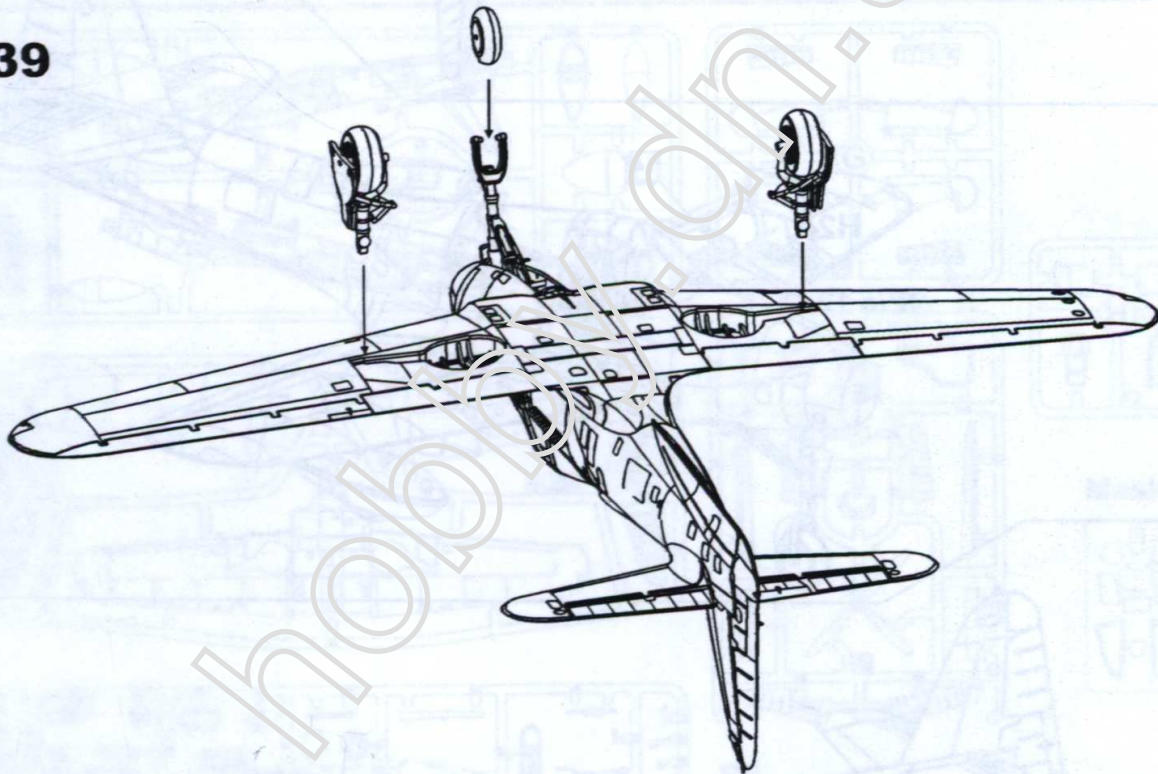

40

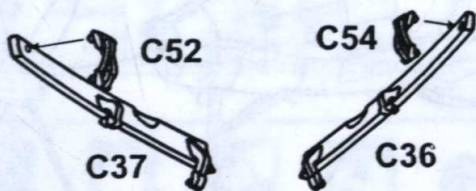

41

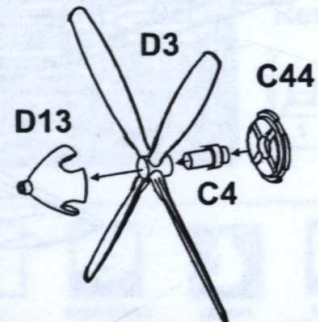

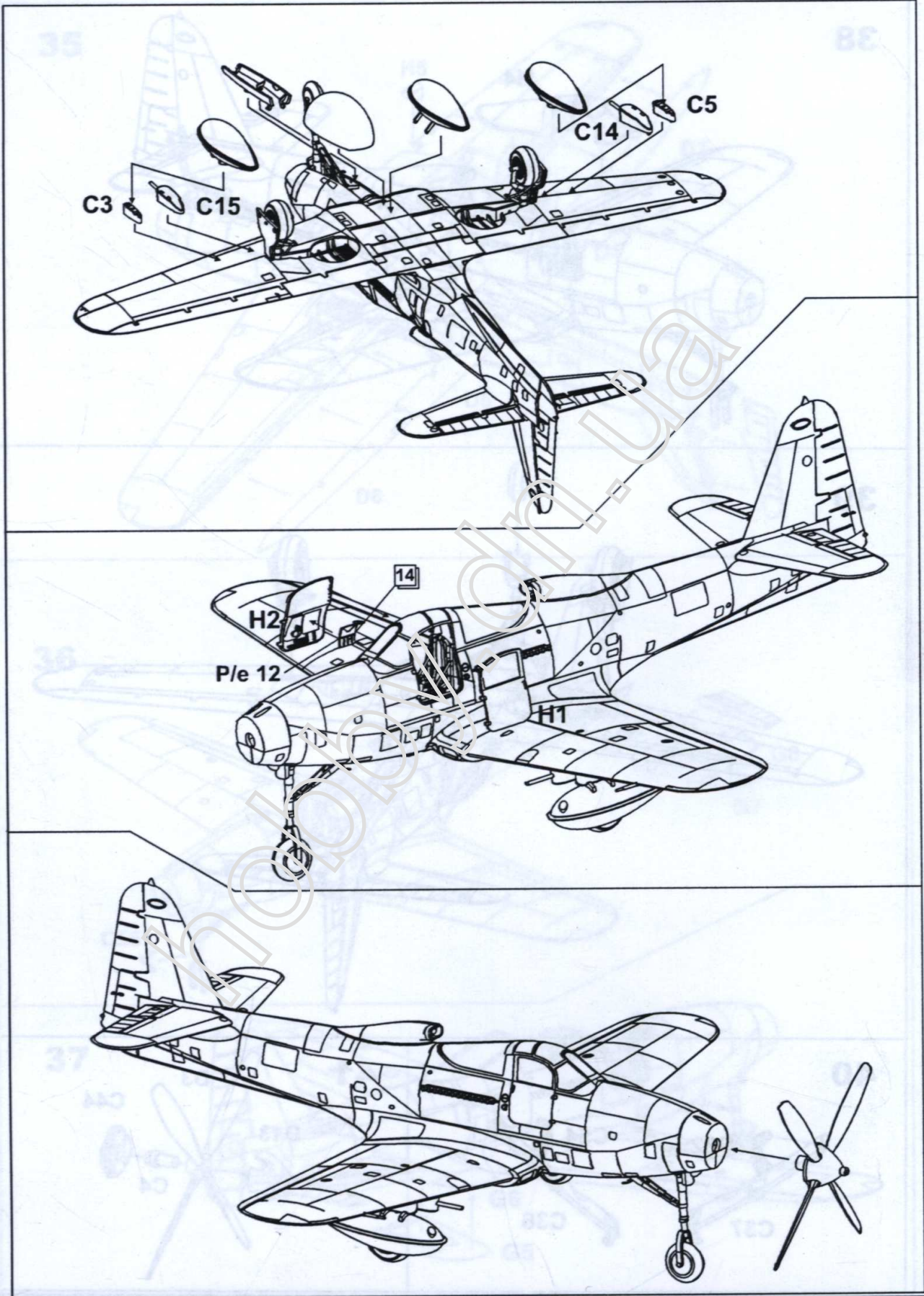

PAINT MANUAL

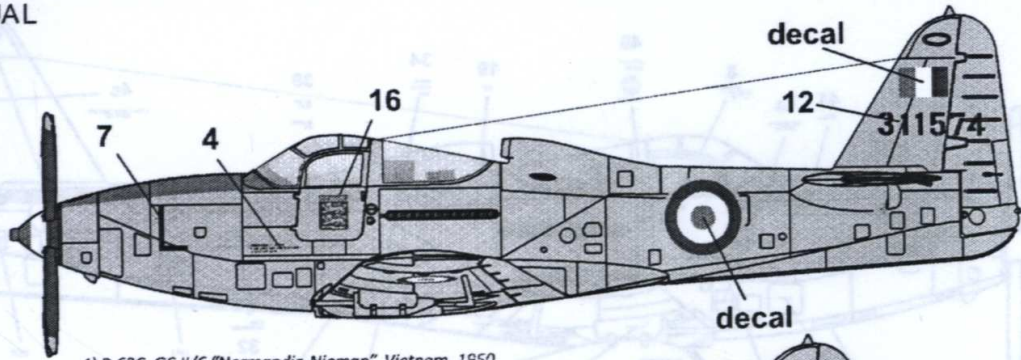

4) P-63C, GC II/6 "Normandie-Nieman", Vietnam, 1950

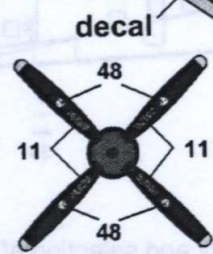
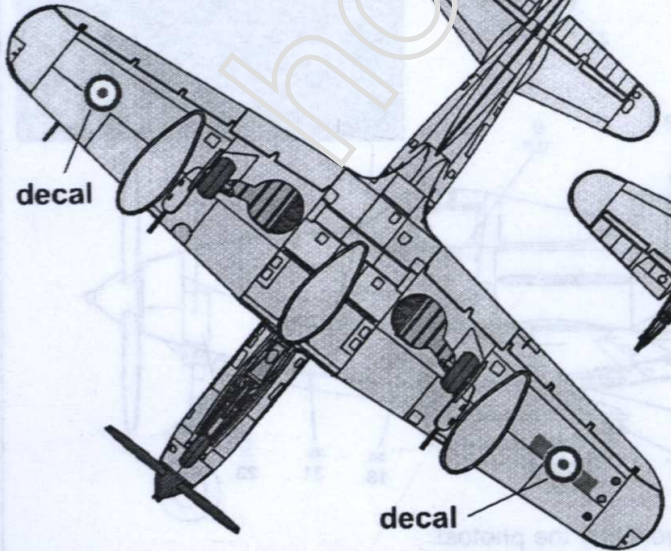
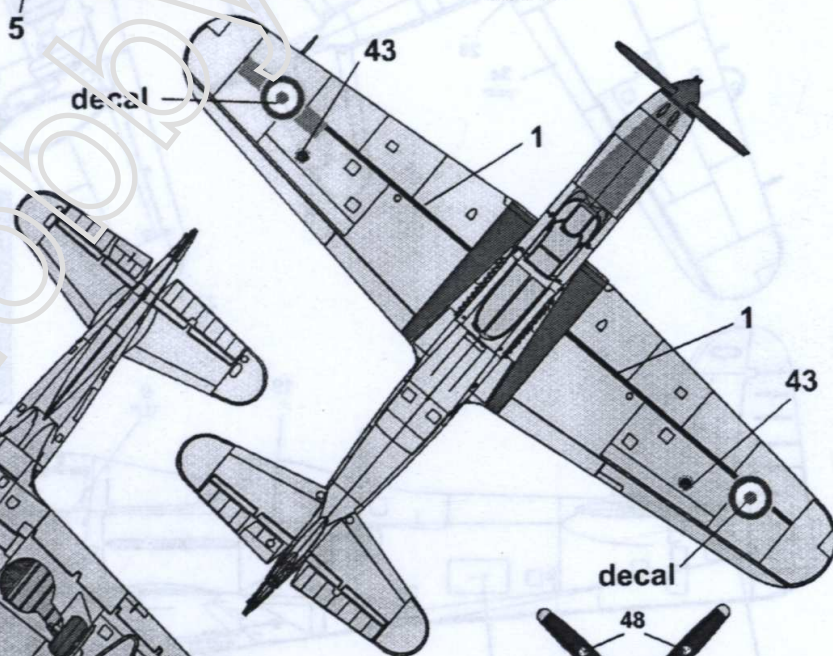
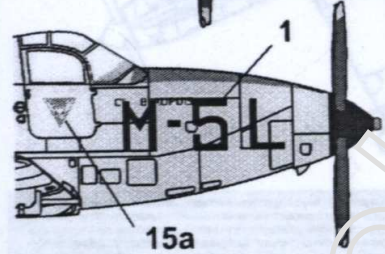
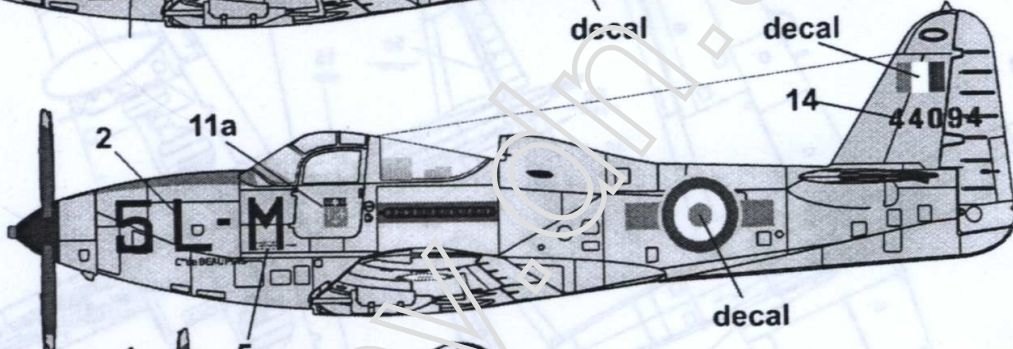
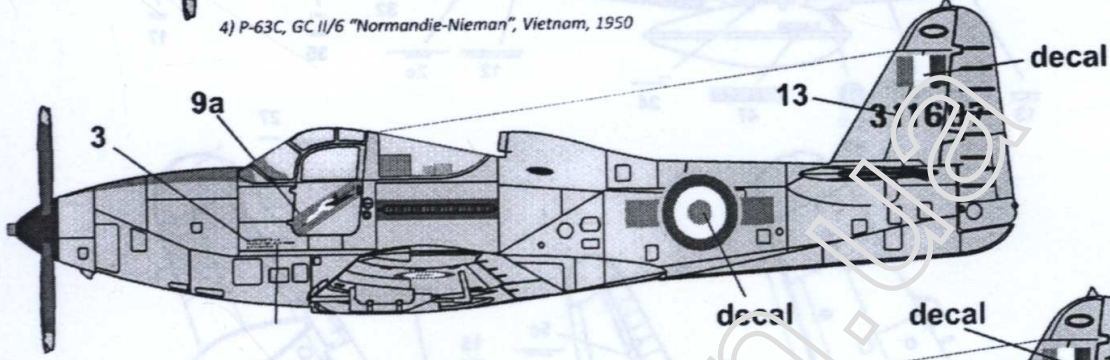

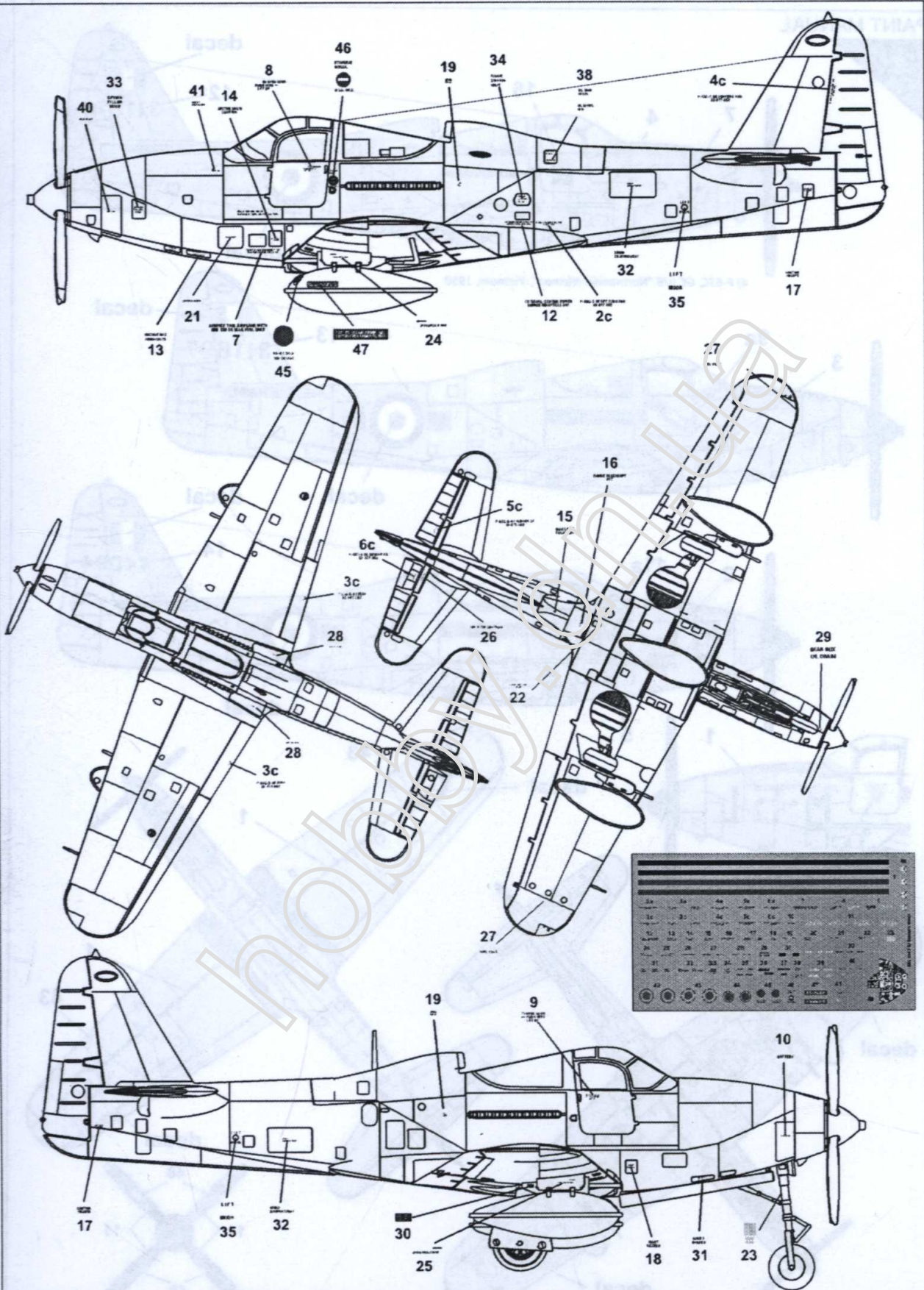

Availability and selection of items designations verify by the photos!