



№ 72-409

Messerschmitt BF.109 D-1

The Messerschmitt Bf 109's versatility and time in service with both the German Luftwaffe and other foreign air forces, numerous variants were produced over the eight years of service with the Luftwaffe and even more were produced by its foreign service.

The Me 109D (codnamed "DORA") was the first major production model of the Messerschmitt Bf 109 fighter.

The D - 1 as eventually produced was thus very similar to the earlier "C" - series machines. Minor changes were made to the tail wheel, and the airframe had been slightly strengthened in preparation for the DB 600 engine. The 109D was armed with four MG 17 machine guns, two in the wings and above the engine cowling.

It entered production in the spring of 1938. A total of 647 Bf 109D were built.

References:

- Messerschmitt Bf 109 A-D models, KAGERO, M.Lukasik
- Messerschmitt Bf 109, WARPAIN Special N 2,
- Bf 109 part 1. SAM Datafile N 09,
- Me 109 A bis Me 109 E. Aviatic Verlag, 1997.
- Messerschmitt Me-109. W.Ridinger & W Schick,
- Cockpits DSeutscher Flugzeuge 1911-70, P.W. Cohauz,
- Luftwaffe Camouflage and Markings 1933-1945 vol.1, K.A. Merrick,
- Luftwaffe Colours 1935-1945, NIKOKO, Publ., M.Ullmann,
- Luftwaffe Colours vol.1, sec.1 JAGDWAFFE. E.Mombeck,
- Flugzeug Classic Extra MESSERSCHMITT Bf 109 teil 1,
- Flugzeug Classic 1/20076
- Aero Journal N 18

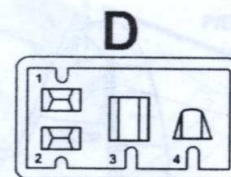
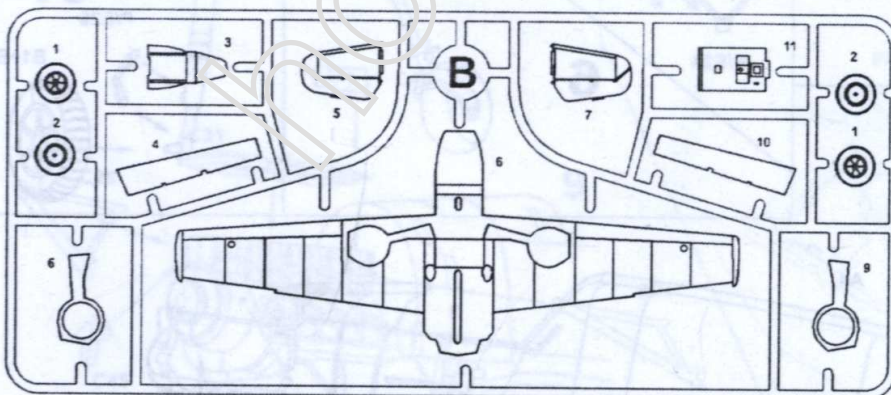
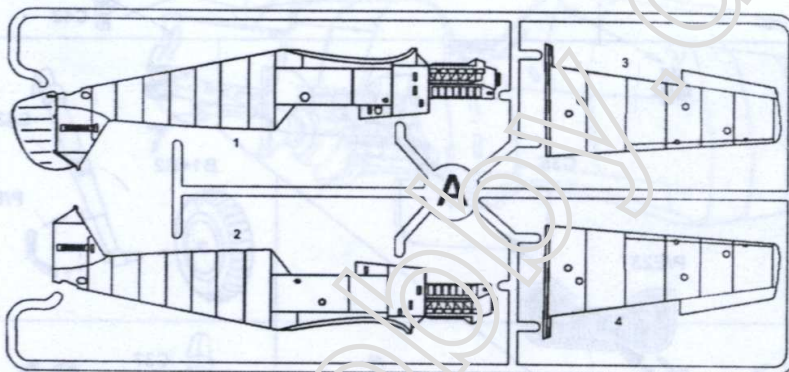

THE CONDITIONAL DENOTATION

УСЛОВНЫЕ ОБОЗНАЧЕНИЯ



BE CAREFUL
ОСТОРОЖНО



DON'T CEMENT
НЕ КЛЕИТЬ



REMOVE
РЕЗАТЬ



SYMMETRICAL
СИММЕТРИЧНО



MAKE TWO
УДВОИТЬ



OPTIONAL
НЕОБЯЗАТЕЛЬНО



BEND
СОГНУТЬ



OPEN WHOLE
СВЕРЛИТЬ



CEMENT
КЛЕИТЬ



VARIANTS
ВЫБОР ВАРИАНТА

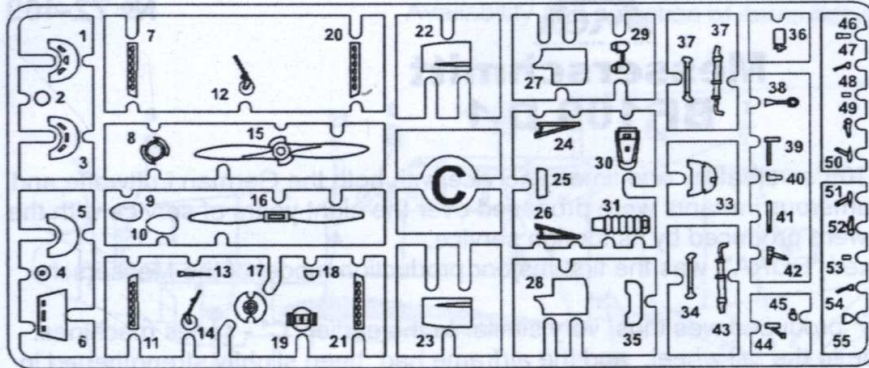

Resin



ASSEMBLY MANUAL



1

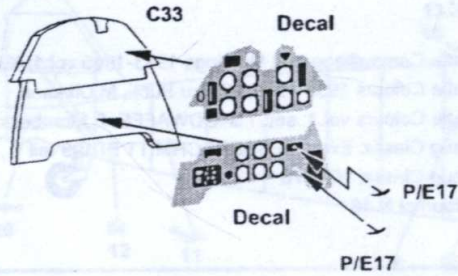

2

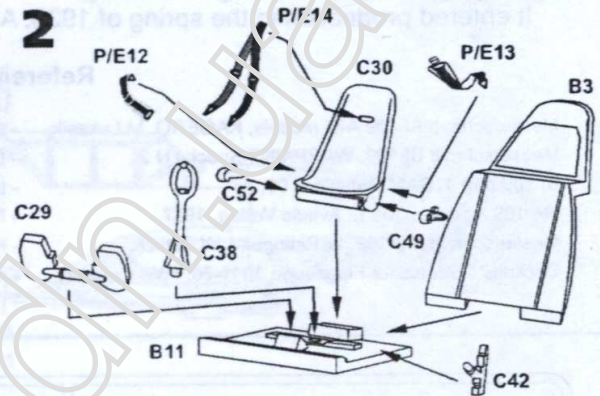

3

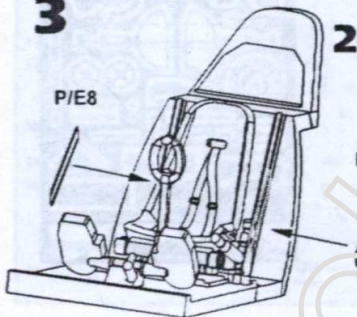

4

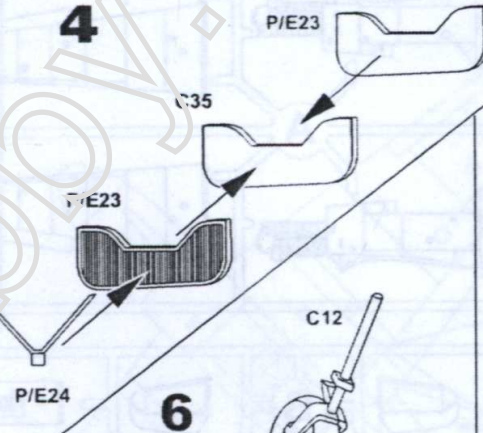

5

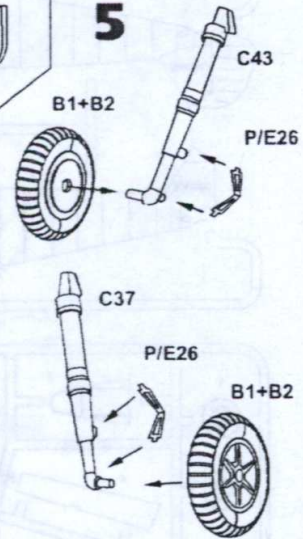

6



7

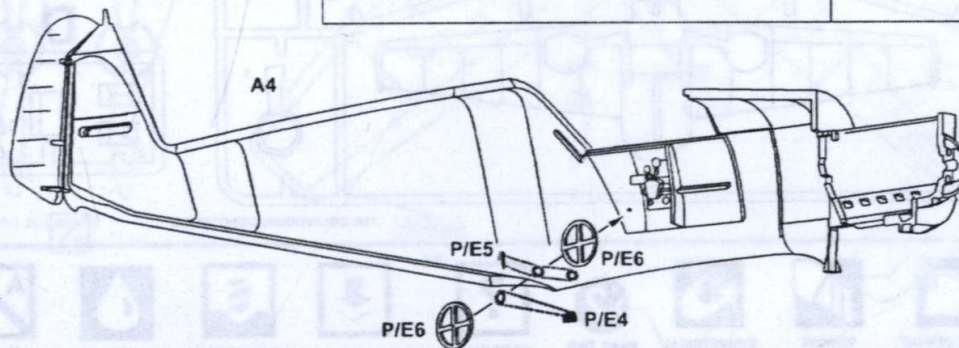

8

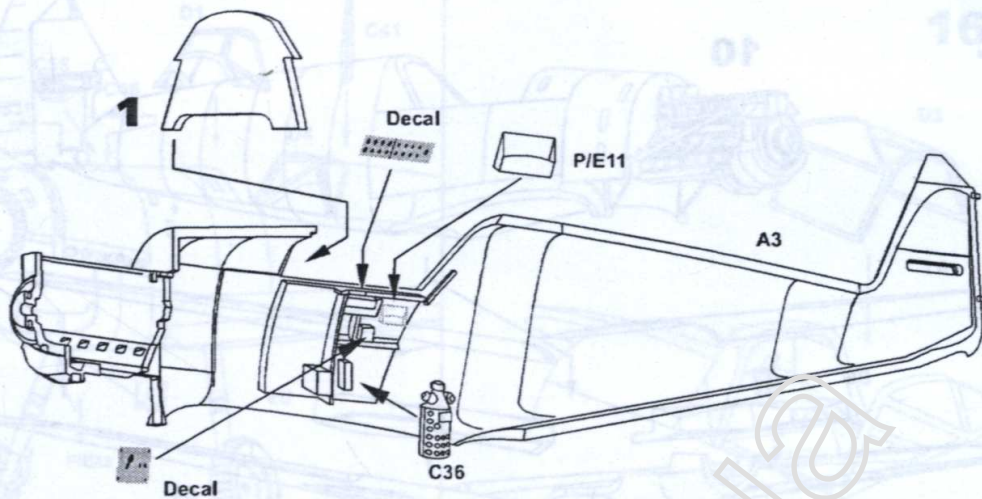

9

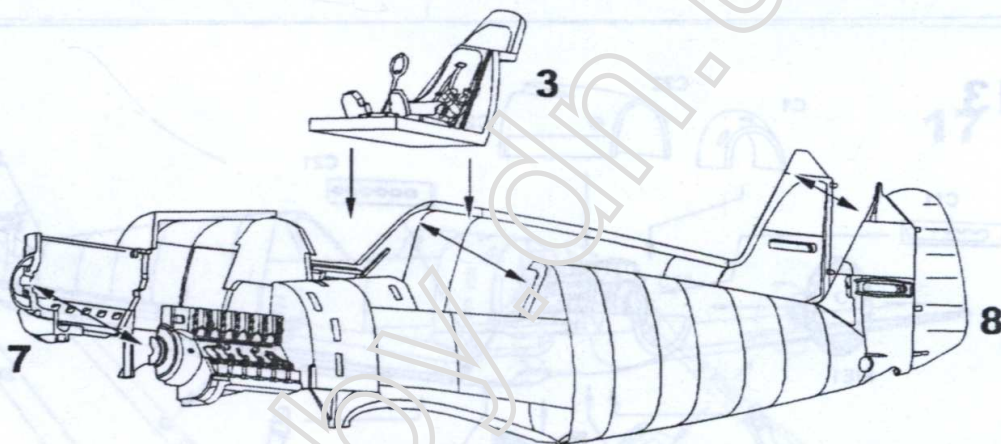

10

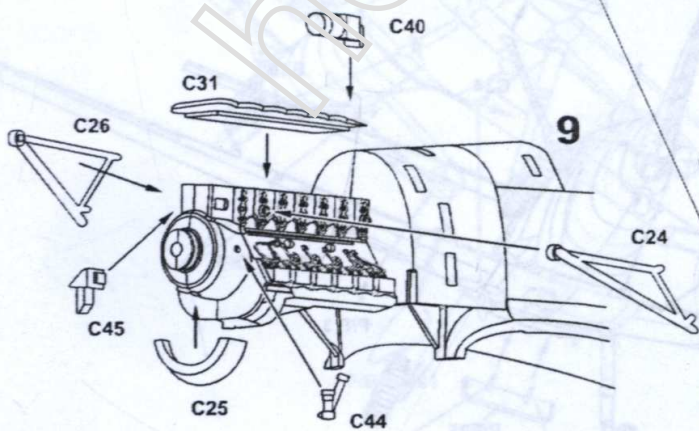

11

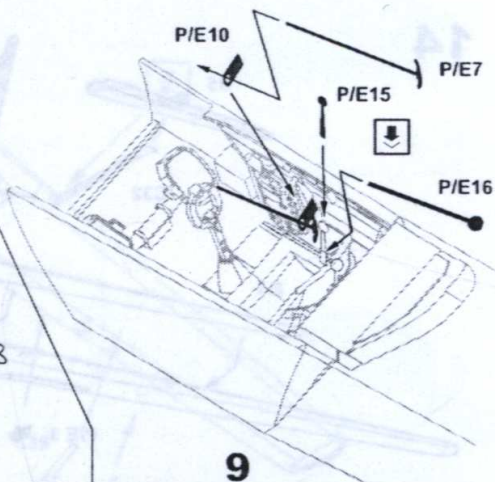

12

10

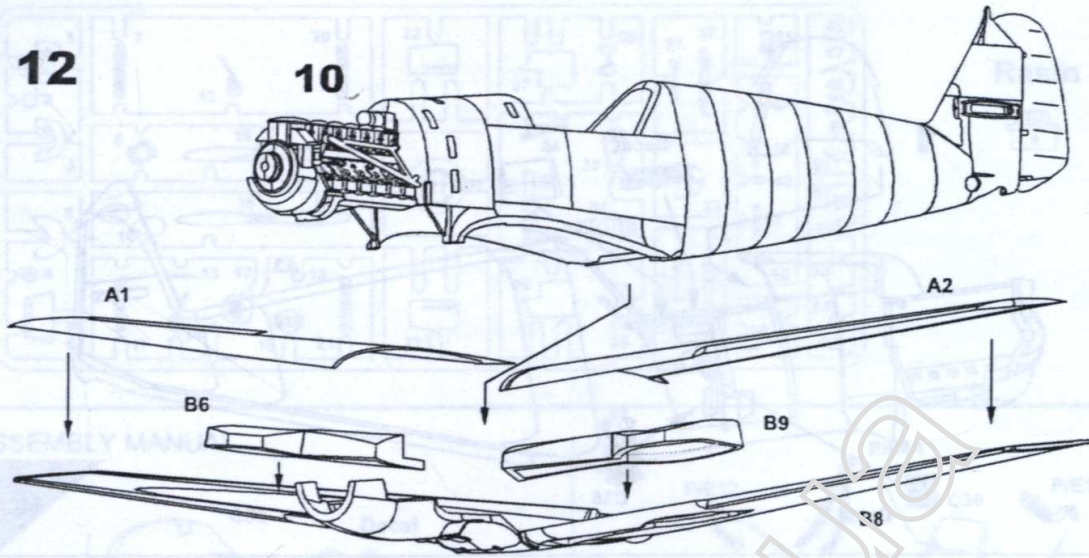

13

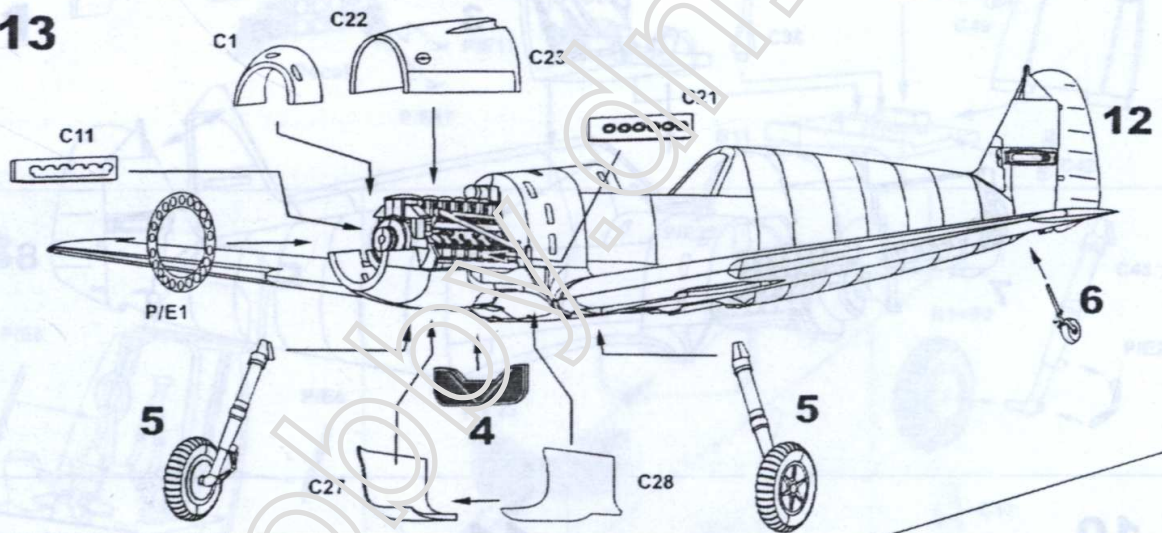

14

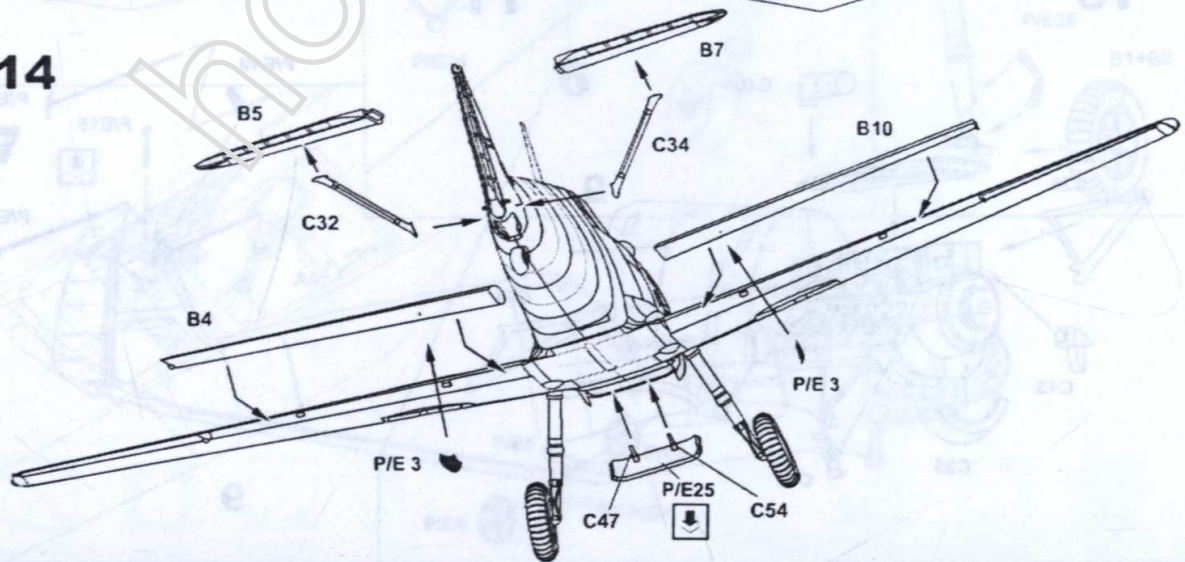

15

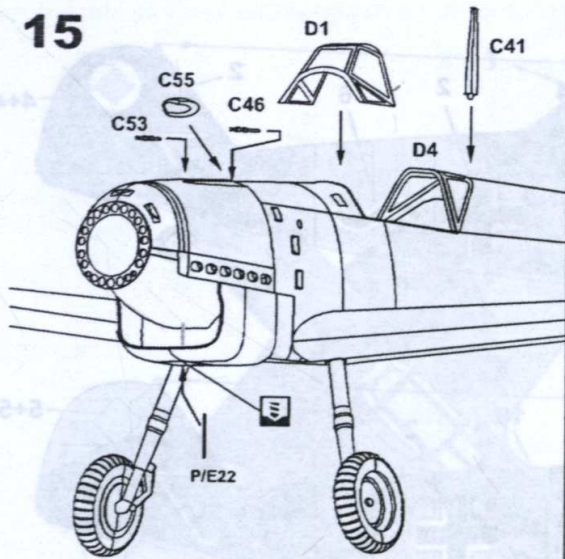

16

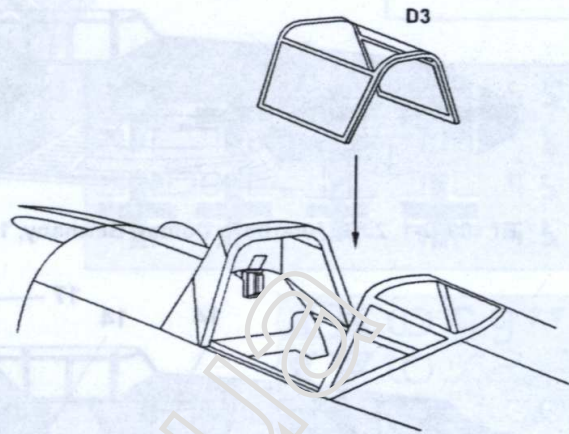

17

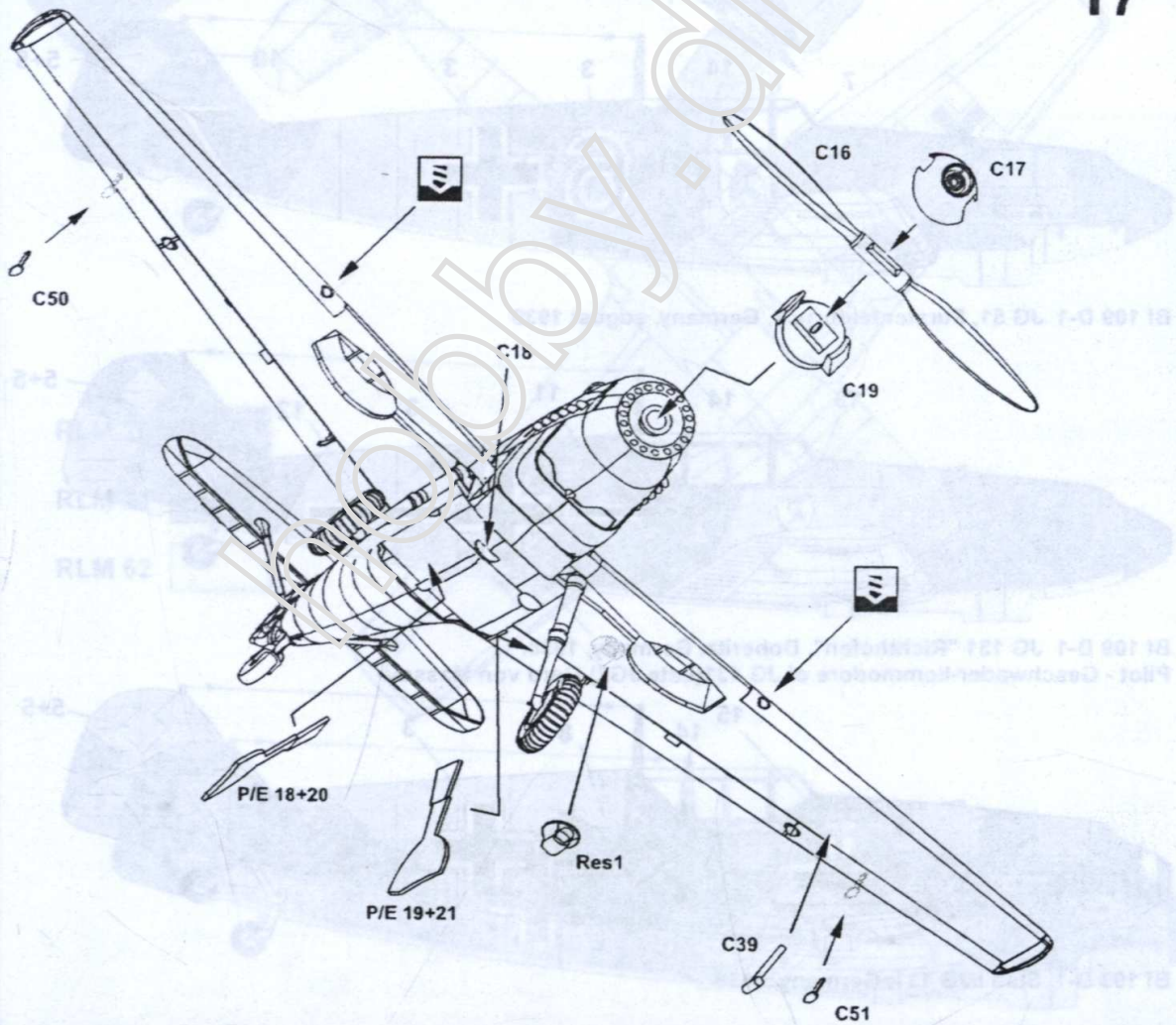

PAINT MANUAL

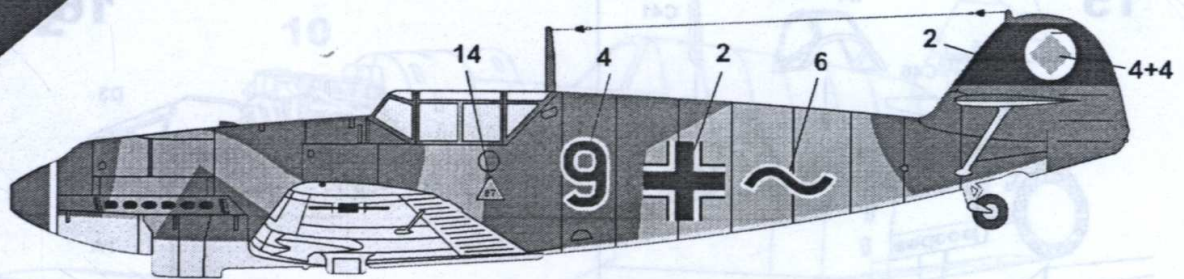

Bf 109 D-1 2JG, Juterborg Damm, Germany, 1937

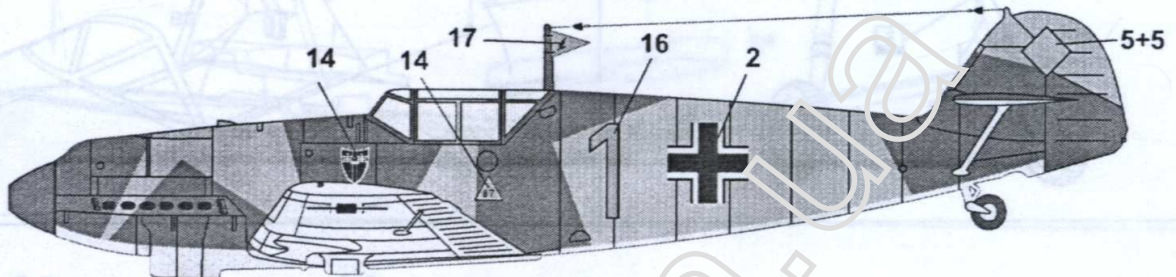

Bf 109 D-1 3./JG 21, Gutenfeld airfield, Germany, 1938

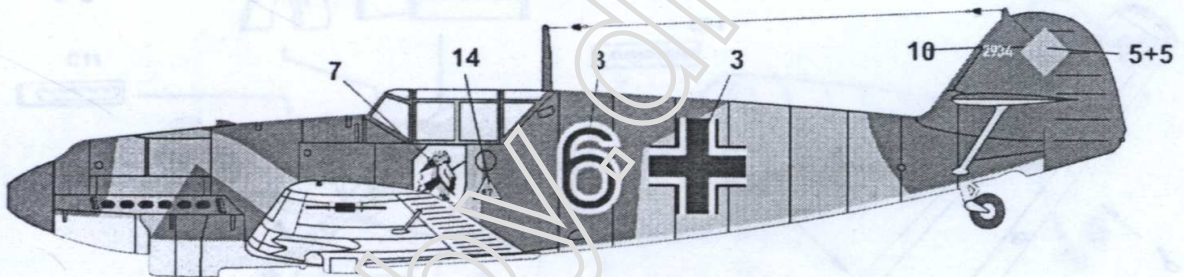

Bf 109 D-1 JG 51, Furstenfeldbruck, Germany, august 1939

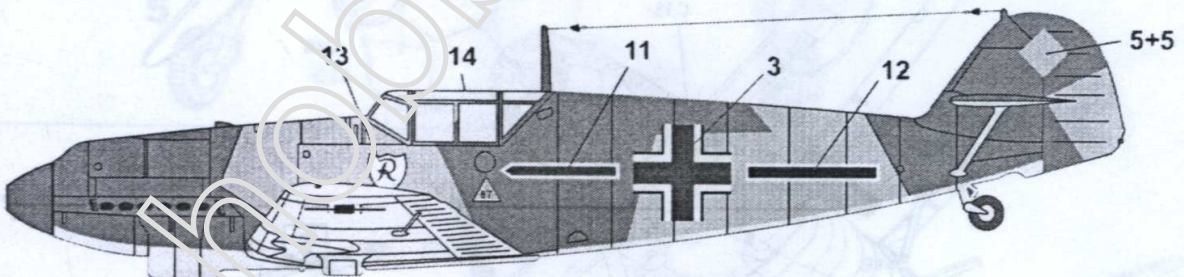



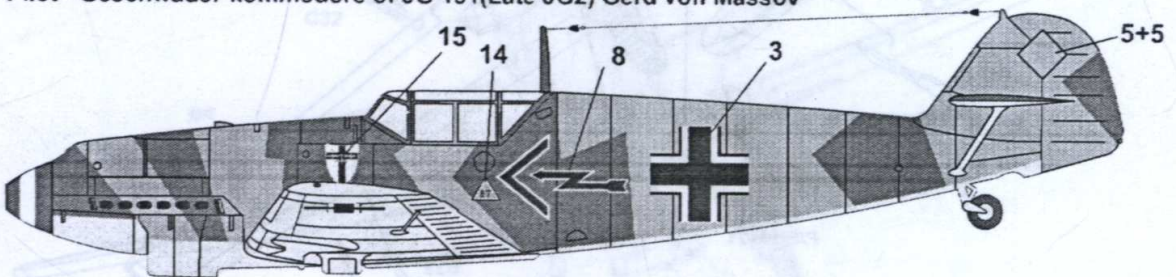

Bf 109 D-1 JG 131 "Richthofen", Doberitz, Germany, 1938.
Pilot - Geschwader-kommodore of JG 131(Late JG2) Gerd von Massov

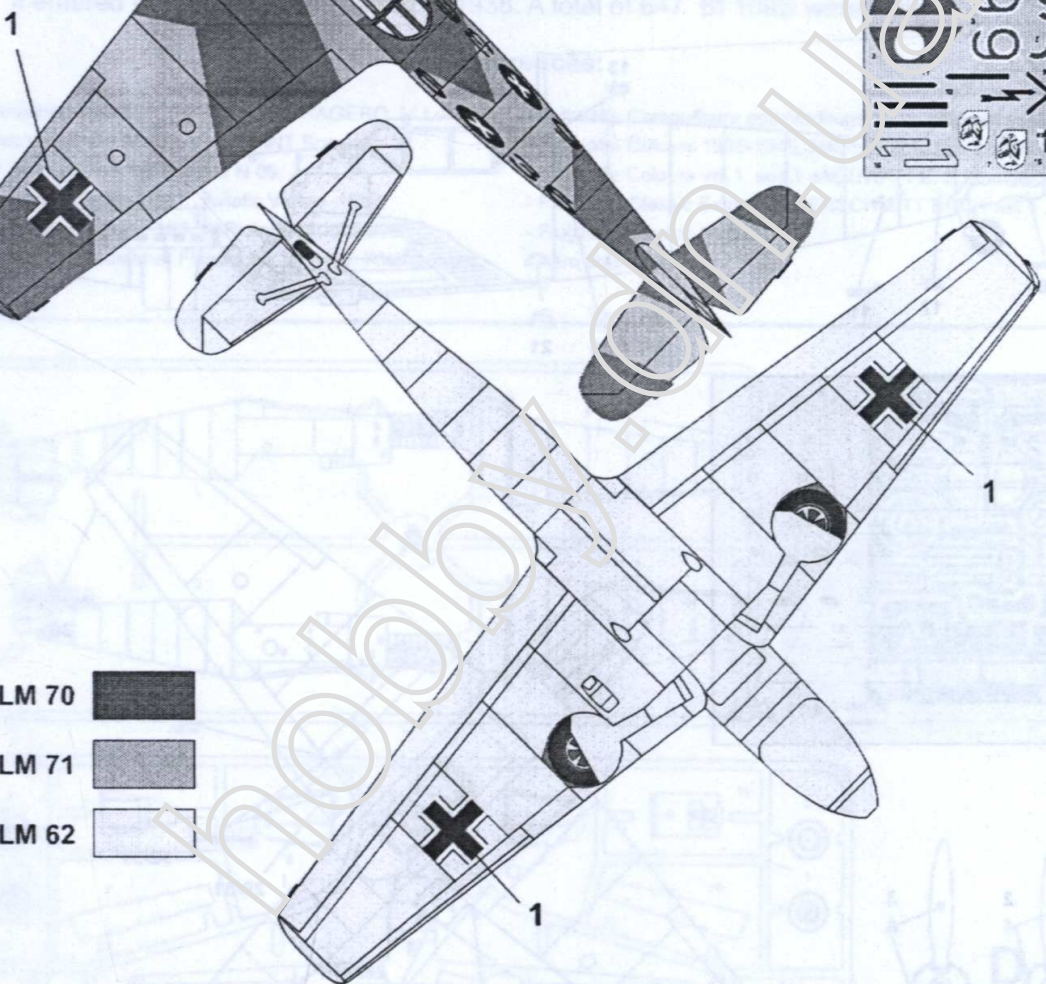
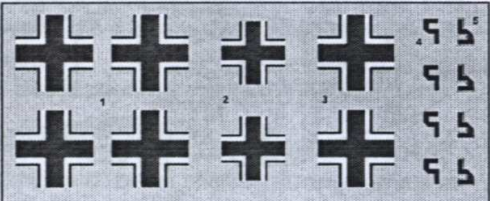
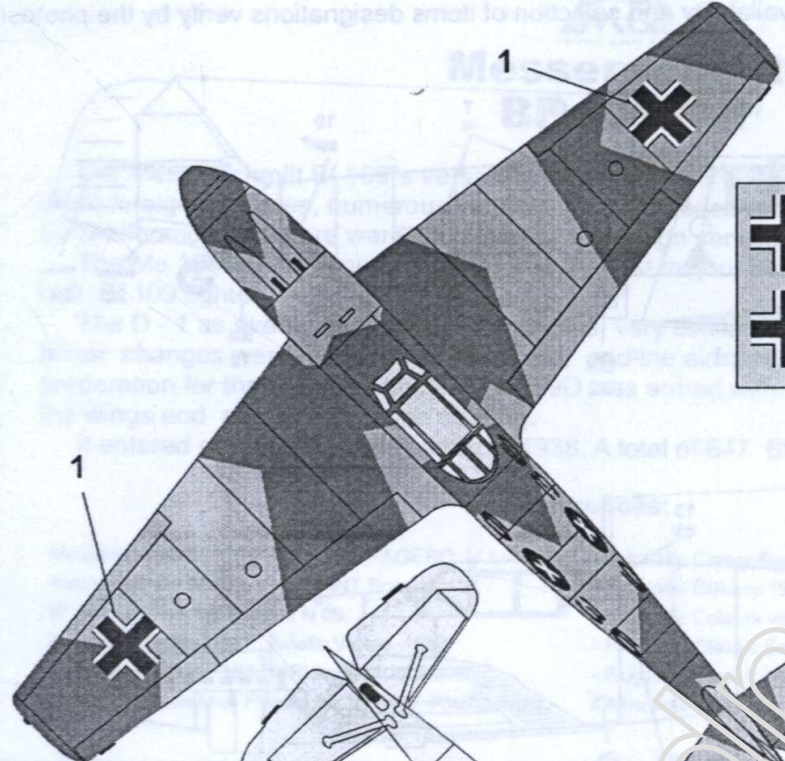
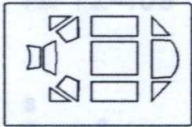

Bf 109 D-1 Stab I/JG 131, Germany, 1938

Always check the location of items designations verify by the product



- RLM 70 
- RLM 71 
- RLM 62 

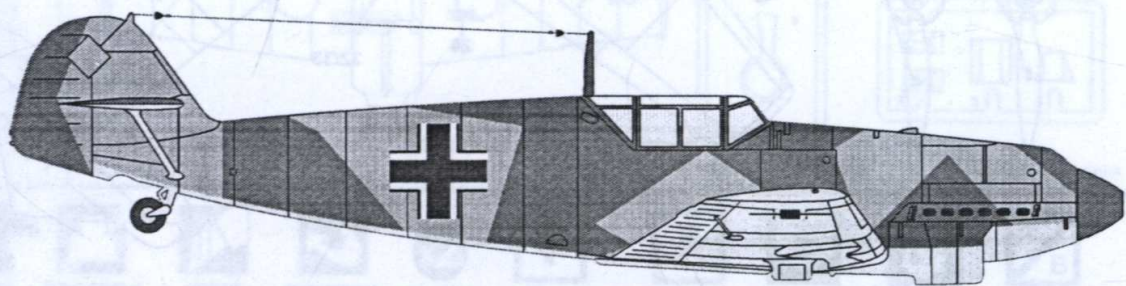

Availability and selection of items designations verify by the photos!

