

# Messerschmitt BF.109D Legion Condor

The Messerschmitt Bf 109's versatility and time in service with both the German Luftwaffe and other foreign air forces, numerous variants were produced over the eight years of service with the Luftwaffe and even more were produced by its foreign service.

Production of the Bf 109C began in the spring of 1938.

The Bf 109C was originally meant to be the last major model of the Bf 109 to use the Jumo 210. It was intended that it would be quickly replaced by the Bf 109D, using a DB 600 engine. However, that engine was not available in suitable numbers, and so the 109D series entered production with a Jumo 210 engine.

The "C" series was produced in relatively small numbers. A total of 58 Bf-109C were built.

### References:

- Messerschmitt Bf 109 A-D models, KAGERO, M.Lukasik
- Messerschmitt Bf 109, WARPAIN Special N 2 ,
- Bf 109 part 1, SAM Datafile N 09,
- Me 109 A bis Me 109 E, Aviatic Verlag, 1997,
- Messerschmitt Me-109, W.Ridinger & W Schick,
- Cockpits DSeutscher Flugzeuge 1911-70, P.W. Cohauz,
- Luftwaffe Camouflage and Markings 1933-1945 vol.1, K.A. Merrick,
- Luftwaffe Colours 1935-1945, Hikoku Publ., M.Ullmann,
- Luftwaffe Colours vol.1, sec.1 JAGD LUFTWAFFE, E.Mombeck,
- Flugzeug Classic Extra MESSEKSCHEMITT Bf 109 teil 1 ,
- Flugzeug Classic 1/20076
- Aero Journal N 12

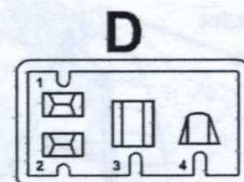
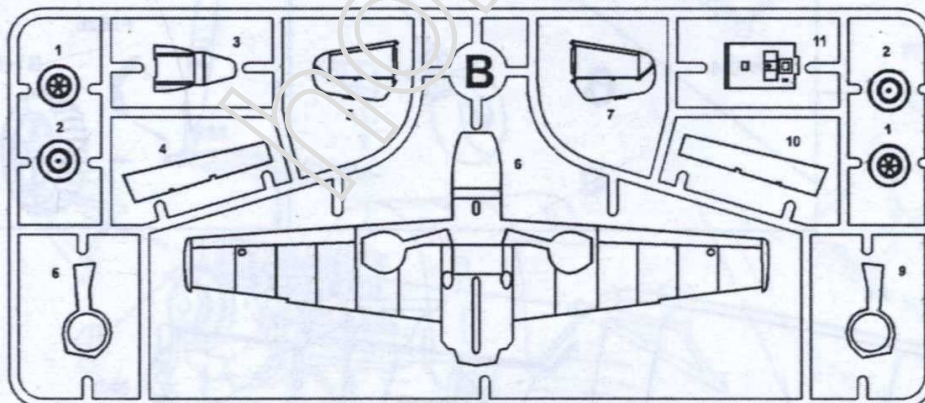
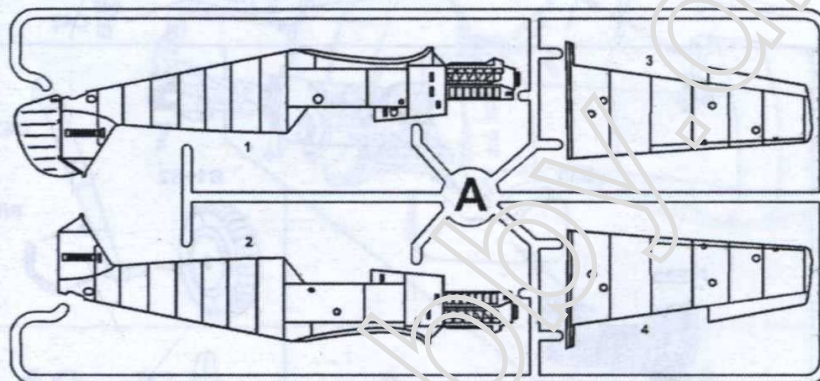

THE CONDITIONAL DENOTATION

УСЛОВНЫЕ ОБОЗНАЧЕНИЯ

**BE CAREFUL**  
ОСТОРОЖНО

**DON'T CEMENT**  
НЕ КЛЕИТЬ

**REMOVE**  
РЕЗАТЬ

**SYMMETRICAL**  
СИММЕТРИЧНО

**MAKE TWO**  
УДВОИТЬ

**OPTIONAL**  
НЕОБЯЗАТЕЛЬНО

**BEND**  
СОГНУТЬ

**OPEN WHOLE**  
СВЕРЛИТЬ

**CEMENT**  
КЛЕИТЬ

**VARIANTS**  
ВЫБОР ВАРИАНТА

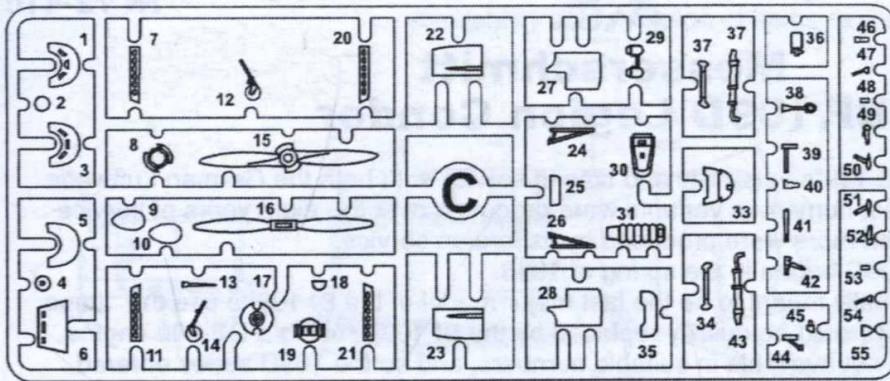

Resin



ASSEMBLY MANUAL

1

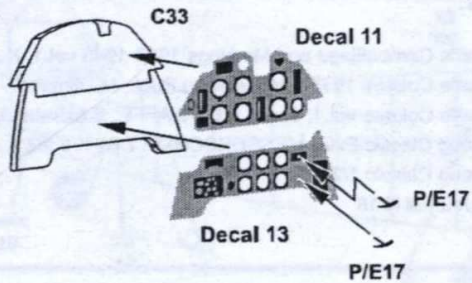

2

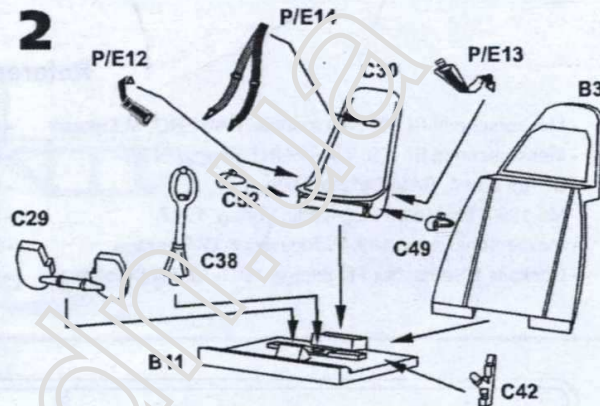

3

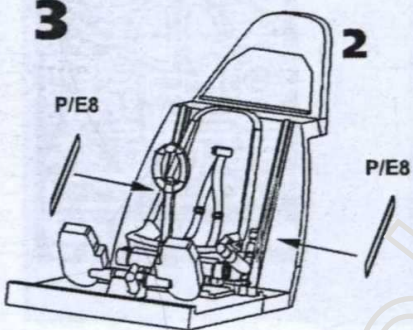

4

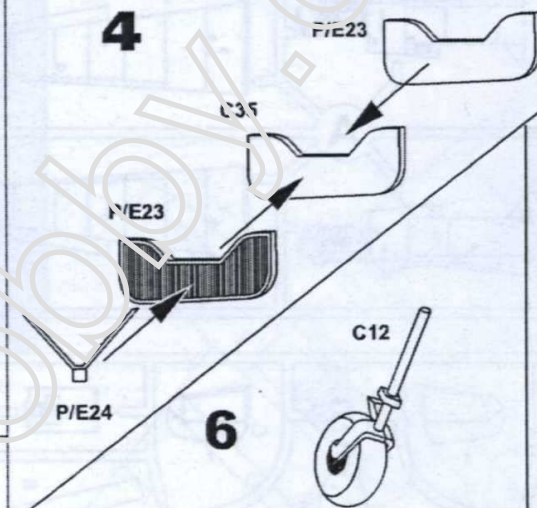

5

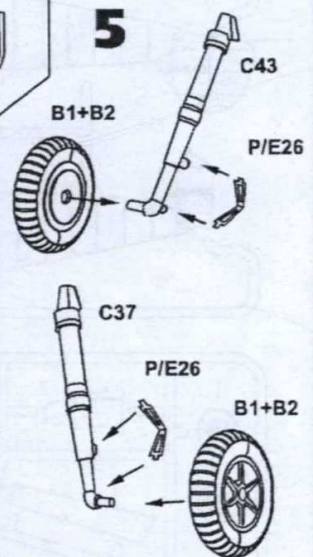

7

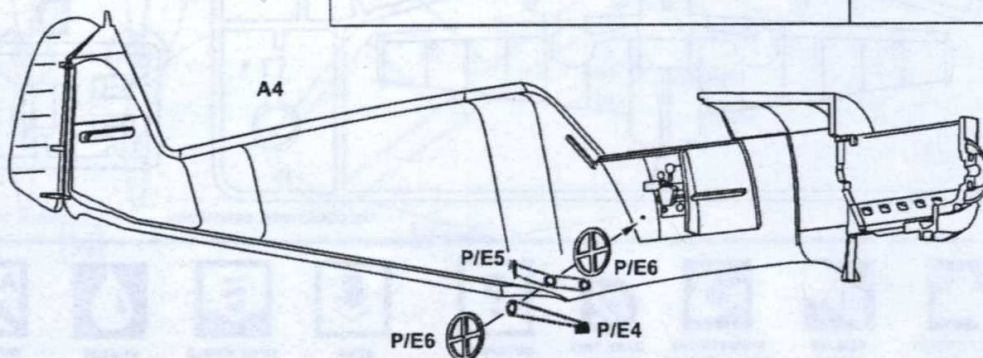

8

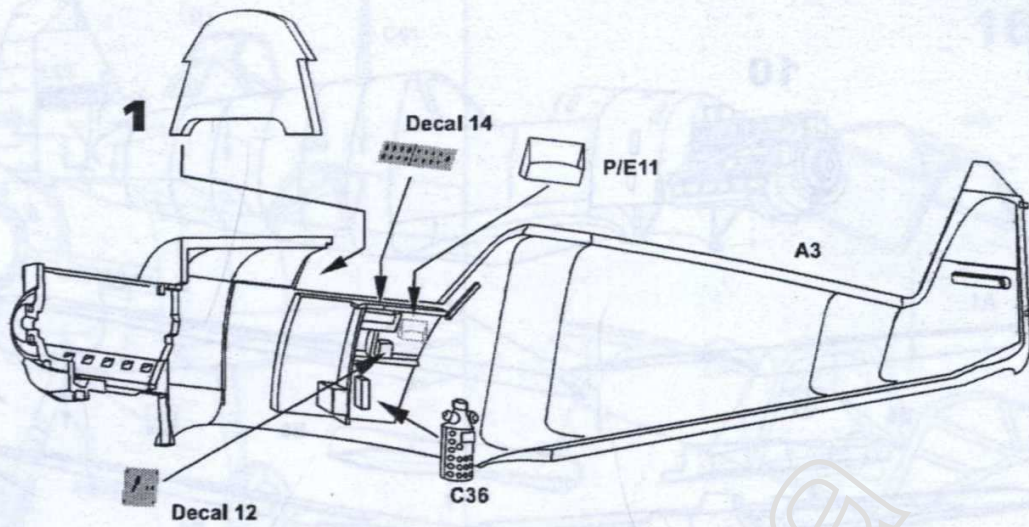

9

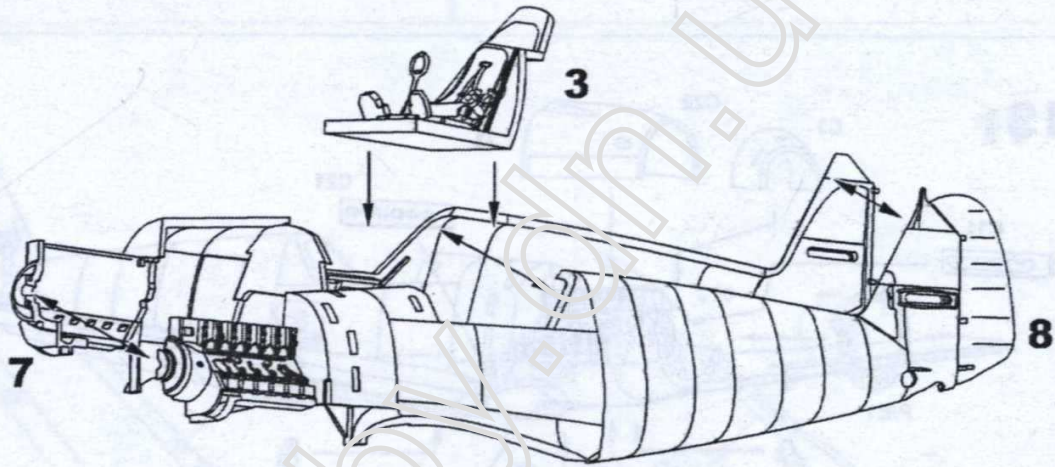

10

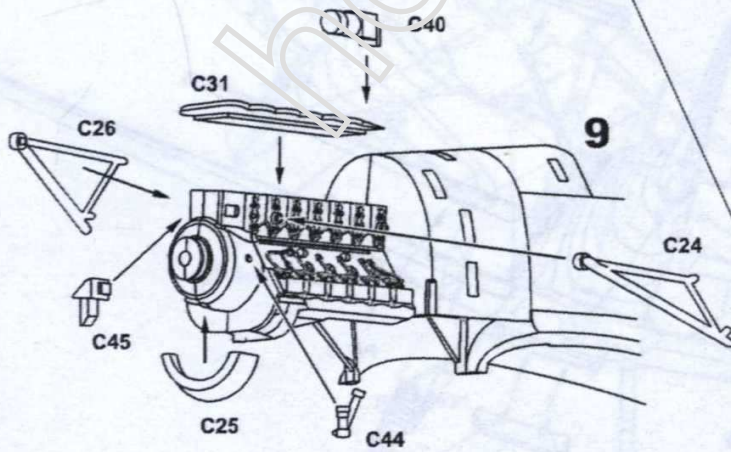

11

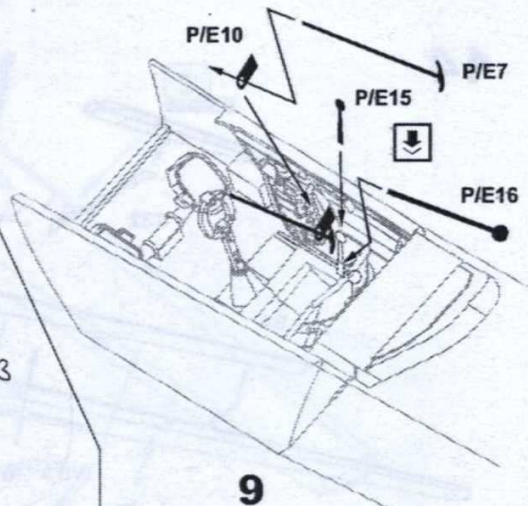

12

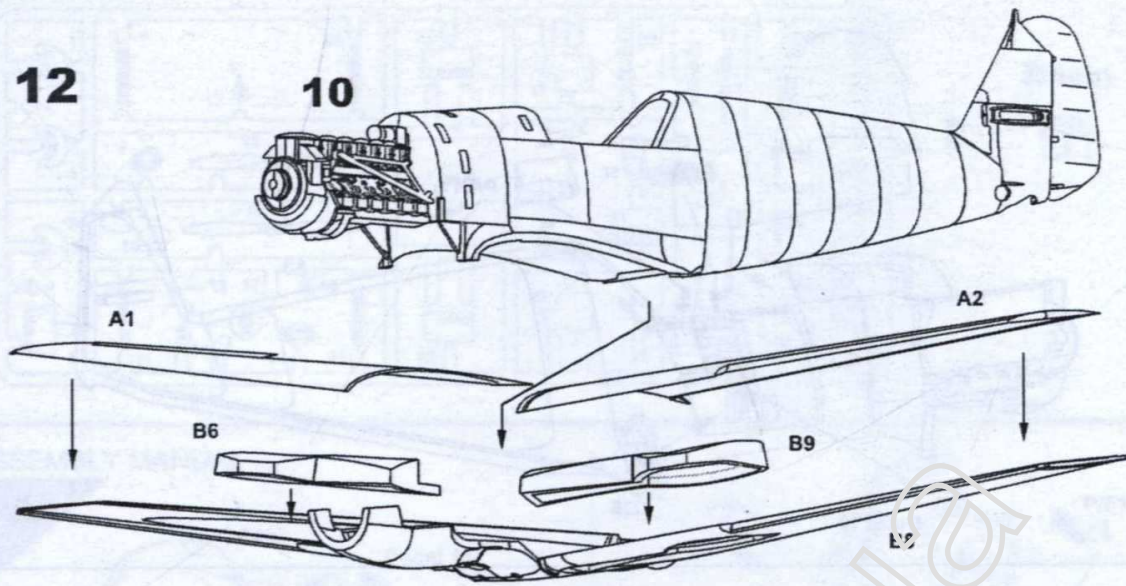

13

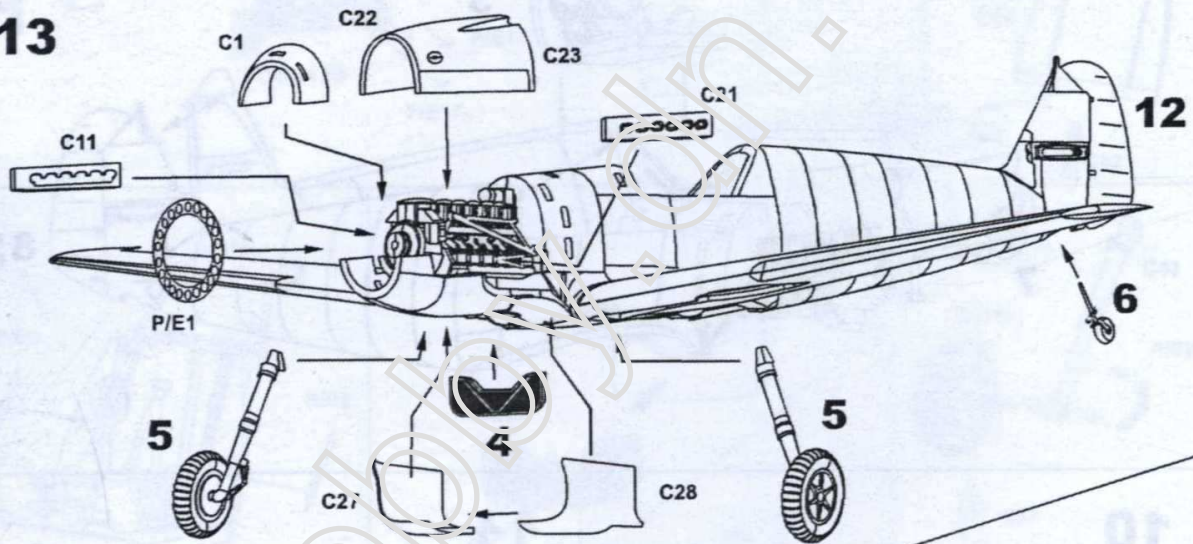

14

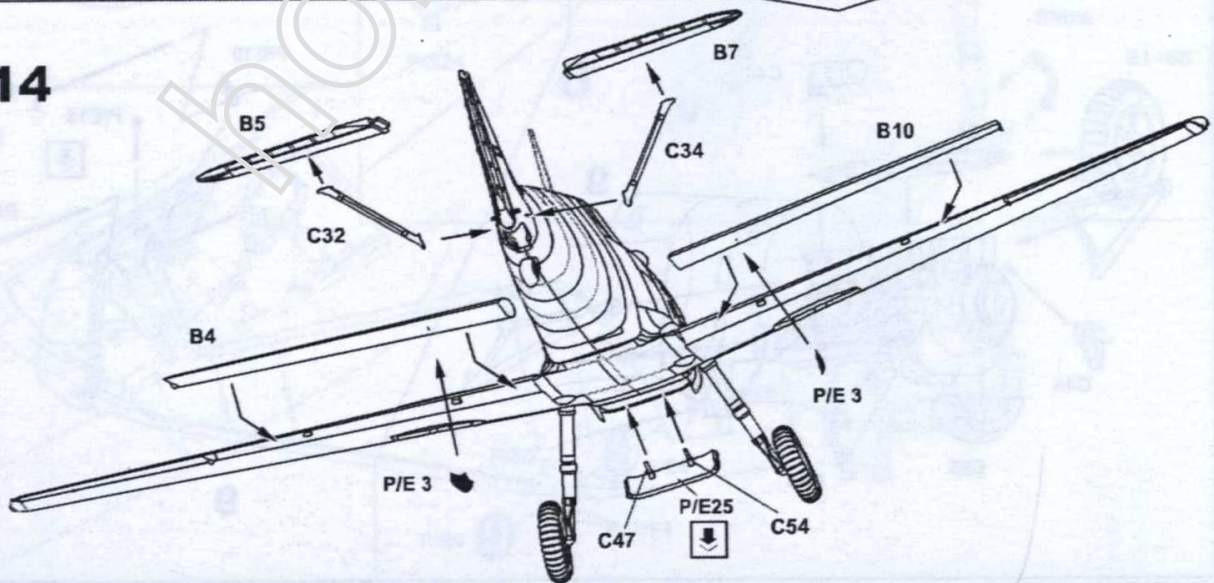

15

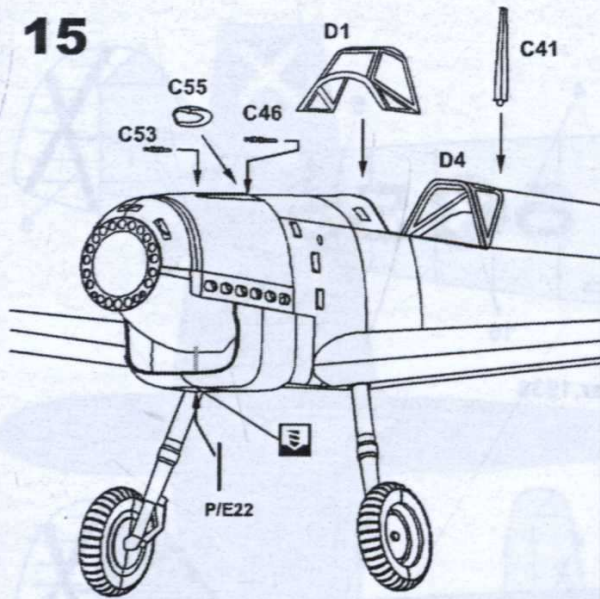

16

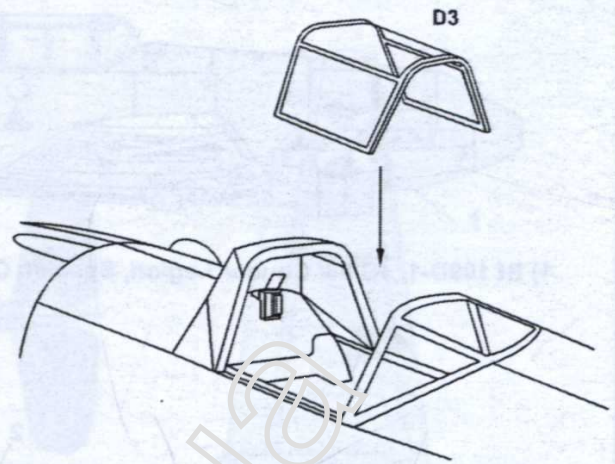

17

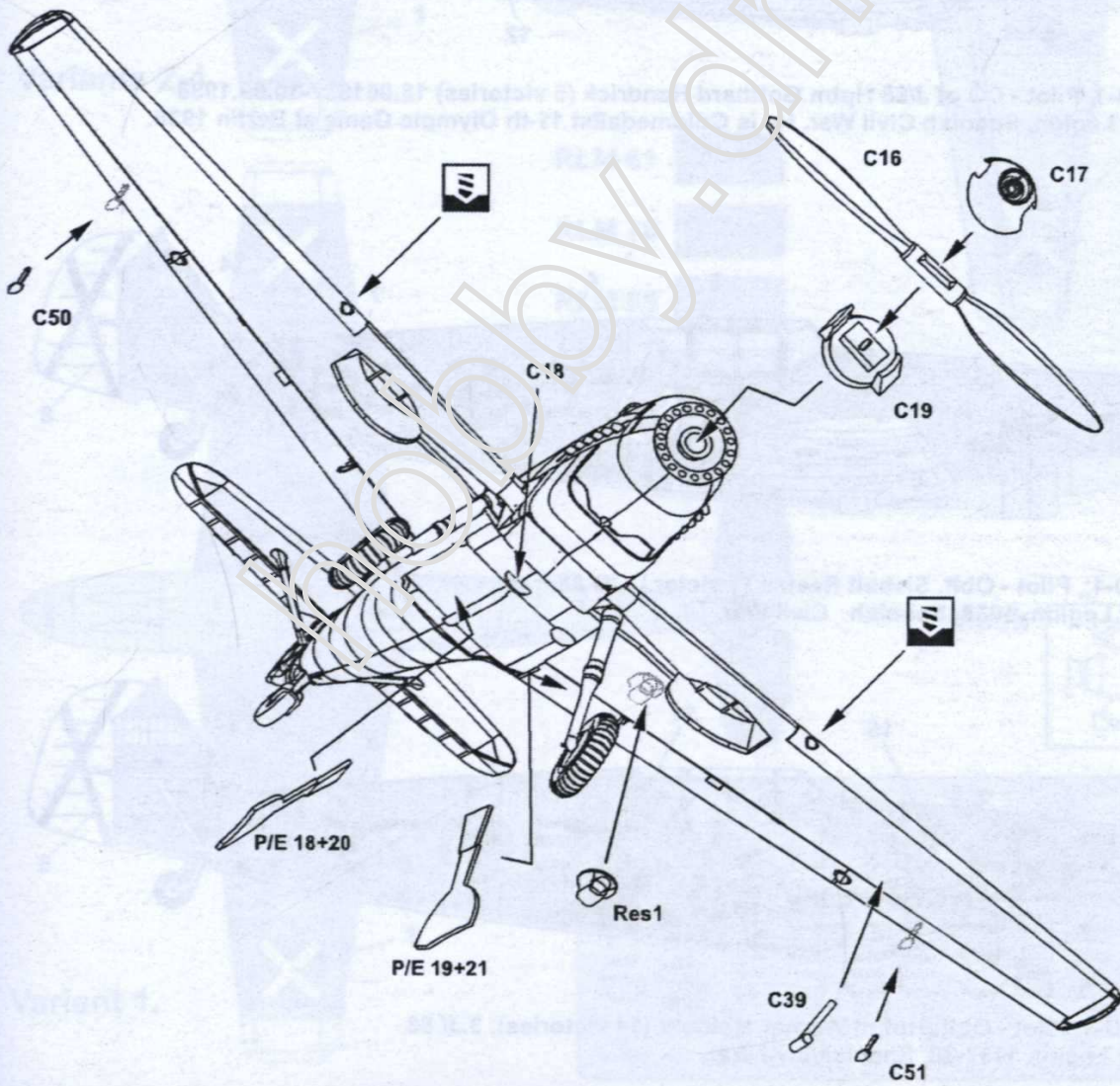

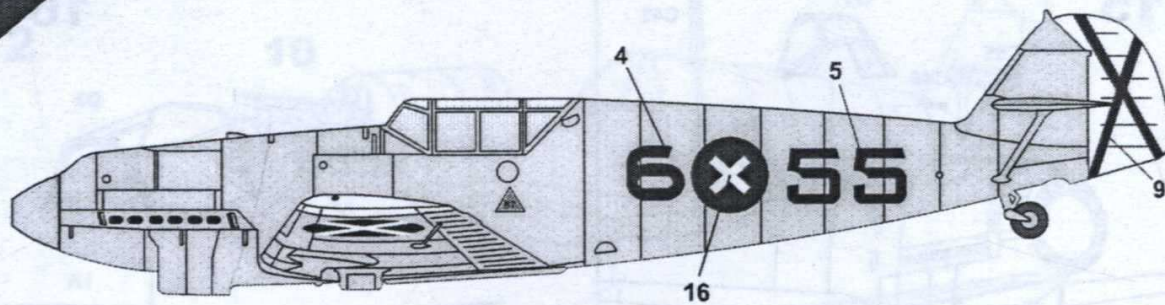

1) Bf 109D-1, JG 88/ Condor Legion, Spanish Civil War, 1938

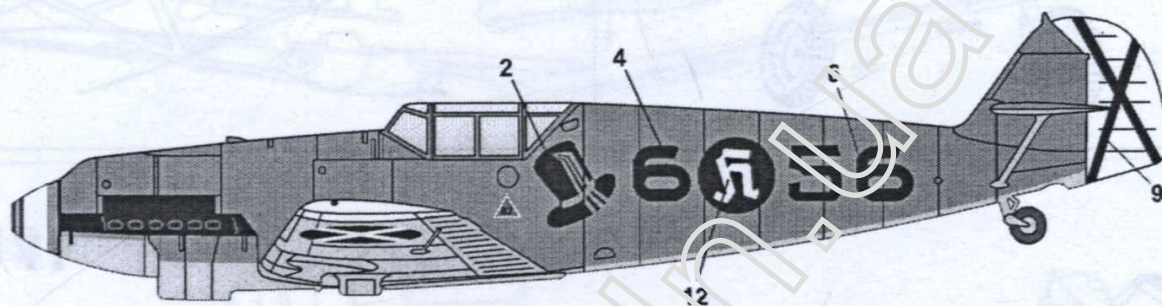

2) Bf 109D-1, Pilot - CO of J/88 Hptm Gotthard Handrick (5 victories) 18.06.1937-10.09.1938  
Condor Legion, Spanish Civil War. He is Goldmedalist 11-th Olympic Game at Berlin 1936.

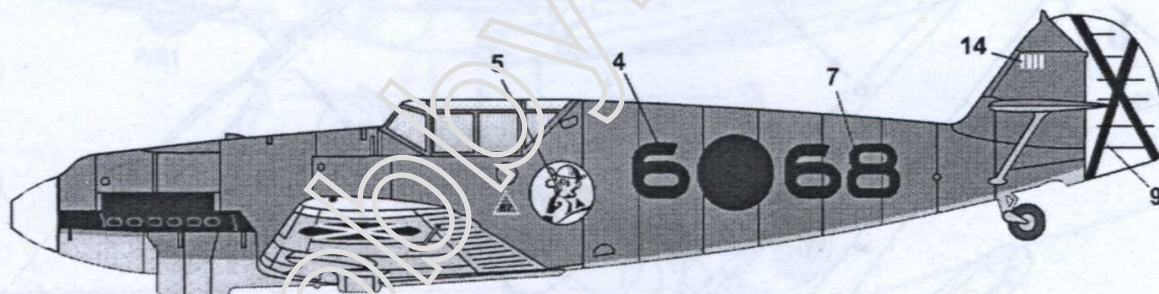

3) Bf 109D-1, Pilot - OER Siebek Reents (1 victor.), JG 88,  
Condor Legion, 1938, Spanish Civil War.

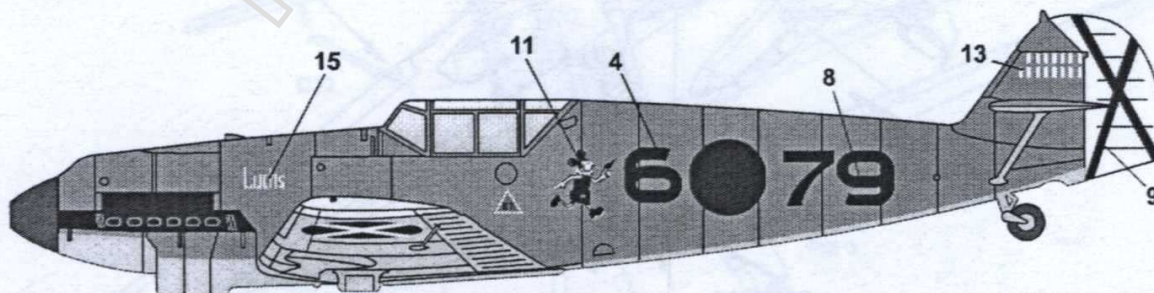

4) Bf 109 D-1 Pilot - Oblt.(Hptm) Werner Molders (14 victories), 3./J/ 88  
Condor Legion 1937-38. Spanish civil War.

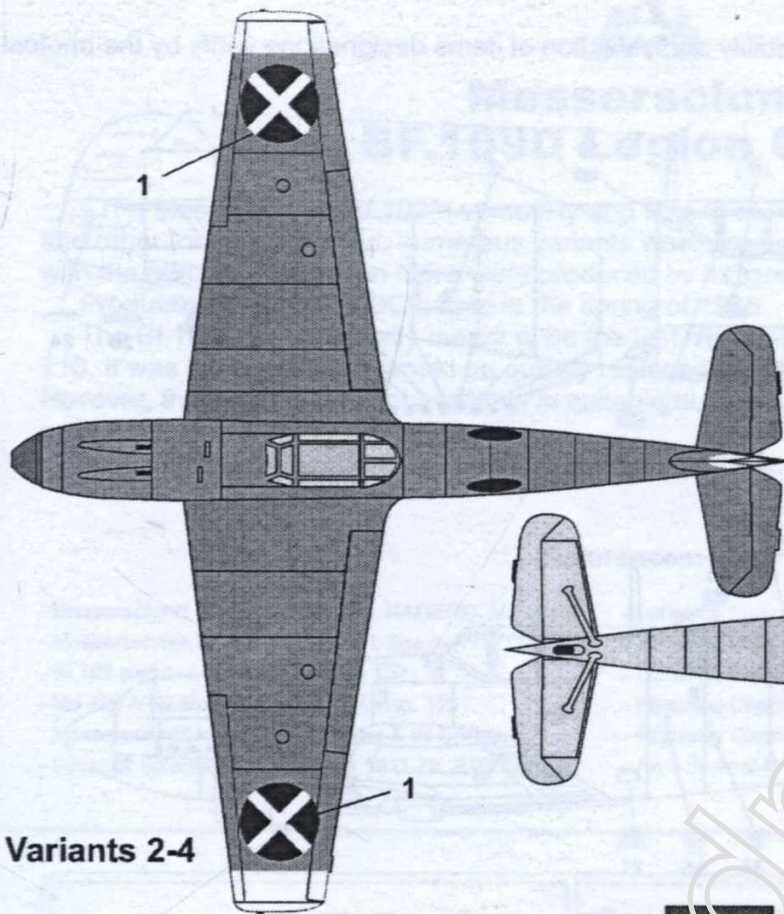



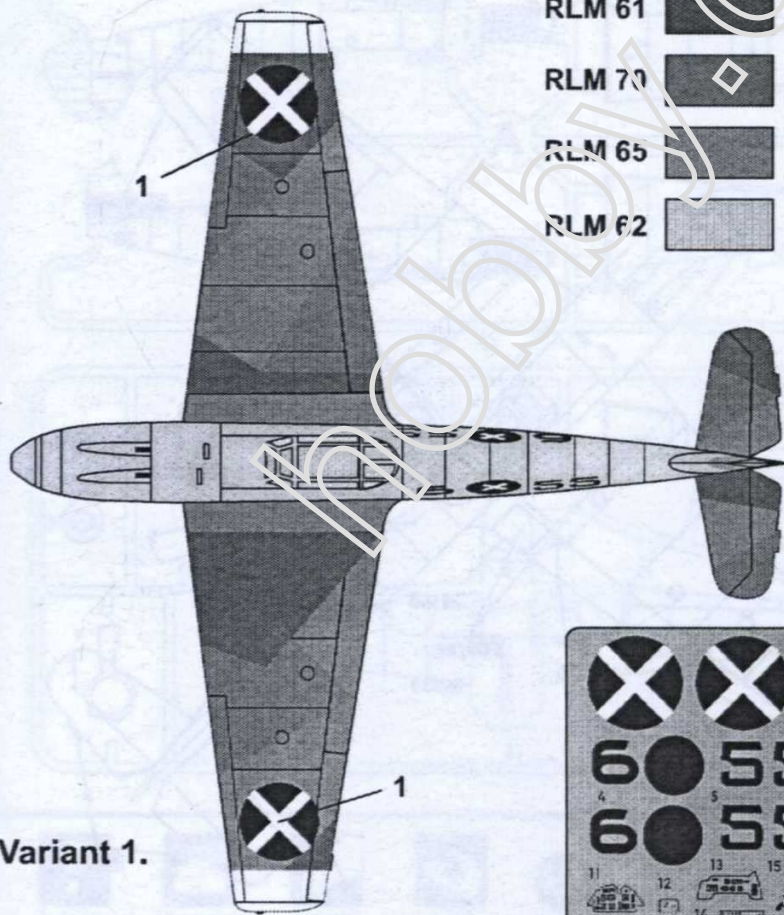

Variants 2-4

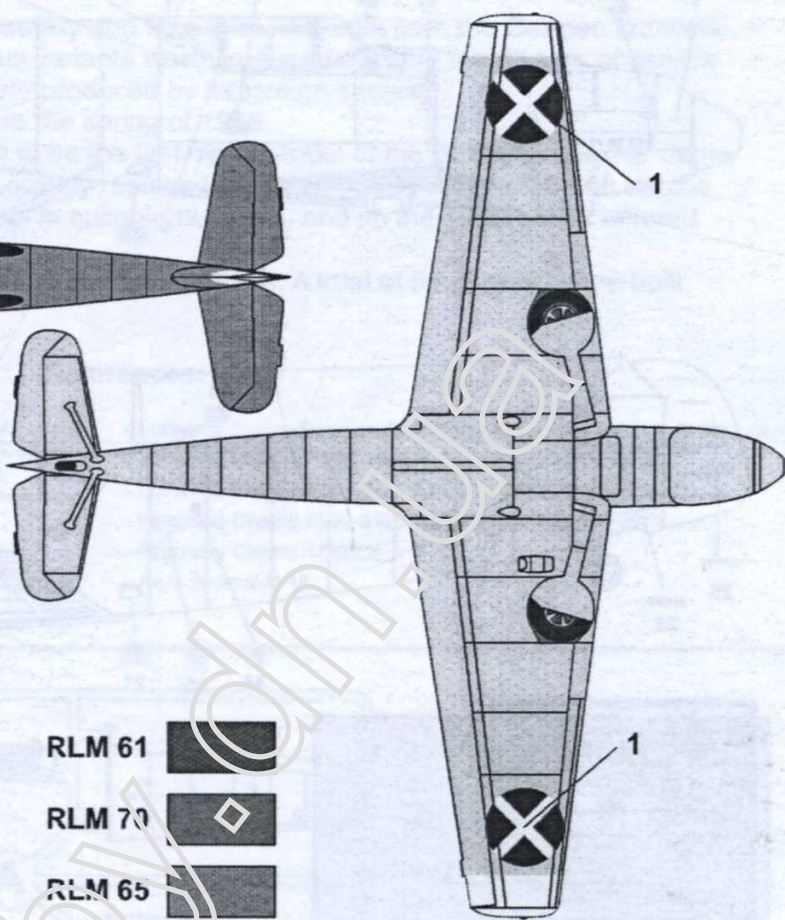

Variant 1.



- RLM 61 
- RLM 70 
- RLM 65 
- RLM 62 

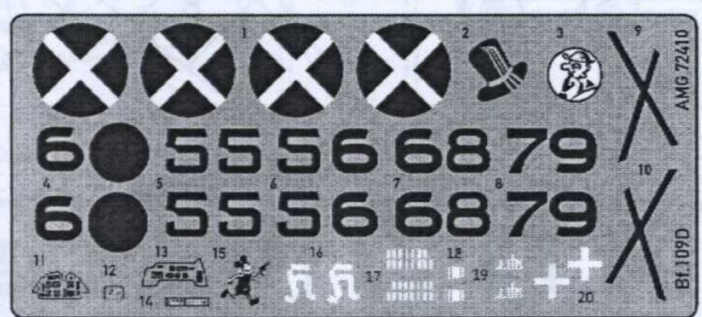
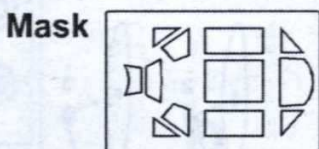

Availability and selection of items designations verify by the photos!

