

## Messerschmitt BF.109 V6/B0 Luftwaffe service

The Messerschmitt Bf 109's versatility and time in service with both the German Luftwaffe and other foreign air forces, numerous variants were produced over the eight years of service with the Luftwaffe and even more were produced by its foreign service.

Between 1937 & 1939 the Bf.109 was used for aerodynamic researches. There fore a Pilot-mast was mounted in front of the cabin and a camera to the fin. Several test flights were clued on the wing to observe the airflow around the wing. In 16.09.1939 (on its 83 flight) for the 1st time so called "wing fences" were mounted on the wing, which were developed by the aeronautical dpt. of the W.messerschmitt AG.

Willy Messerschmitt & Walter Rethel designed the Bf 109 in response to an official government request for a monoplane fighter. They sensible, designed their new fighter around the smallest airframe (length 8,5 m & wingspan 9,7 m), that could accomodate the most powerful motor available at the time, the liquid-cooled 660 HP Junkers Jumo 210A. This design philosophy was to serve the new fighter well during its long combat career.

The Bf 109 prototype first flew 02 05 1935. It was the first fighter to incorporate all of the features that would make the final generation of piston-engine fighters so successful during the WW II. It was an all metal, stressed skin monocoque, single seat, monoplane fighter with an enclosed cockpit and retractable landing gear.

The Me 109's track record is unparalleled. The Bf 109A entered service during the Spanish Civil war with the Condor Legion, where in 1936 it demonstrated its superiority against the I-16 monoplane fighter supplied to the Republican AF by the USSR.

The Bf 109 A was the first serial version of the Bf 109. A total of 22 Bf-109 A were built.

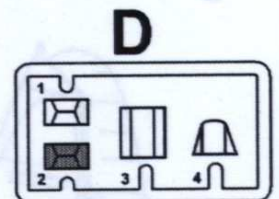
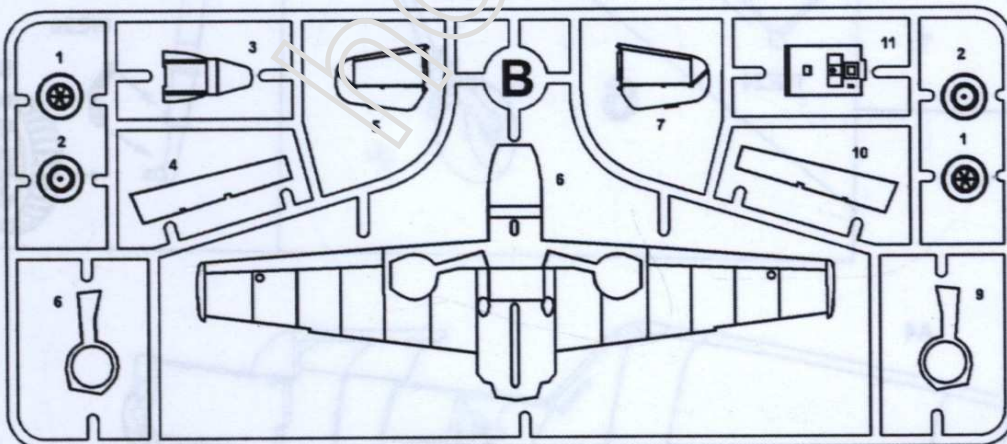
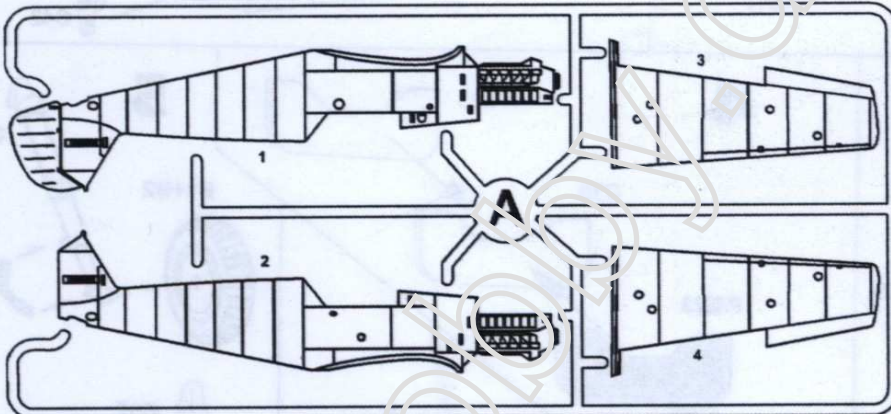

THE CONDITIONAL DENOTATION

УСЛОВНЫЕ ОБОЗНАЧЕНИЯ

**BE CAREFUL**  
ОСТОРОЖНО

**DON'T CEMENT**  
НЕ КЛЕИТЬ

**REMOVE**  
РЕЗАТЬ

**SYMMETRICAL**  
СИММЕТРИЧНО

**MAKE TWO**  
УДВОИТЬ

**OPTIONAL**  
НЕОБЯЗАТЕЛЬНО

**BEND**  
СОГНУТЬ

**OPEN WHOLE**  
СВЕРДИТЬ

**CEMENT**  
КЛЕИТЬ

**VARIANTS**  
ВЫБОР ВАРИАНТА



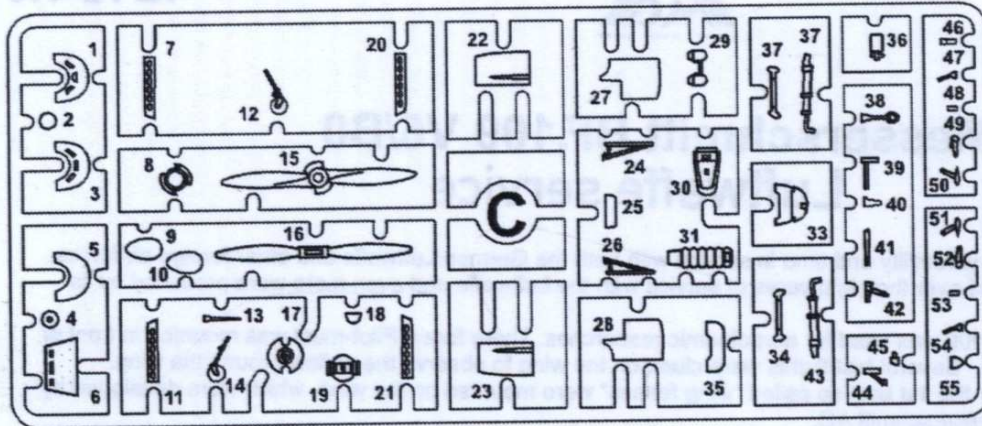

Resin

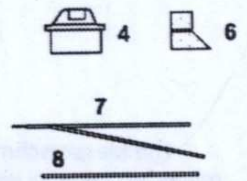

ASSEMBLY MANUAL

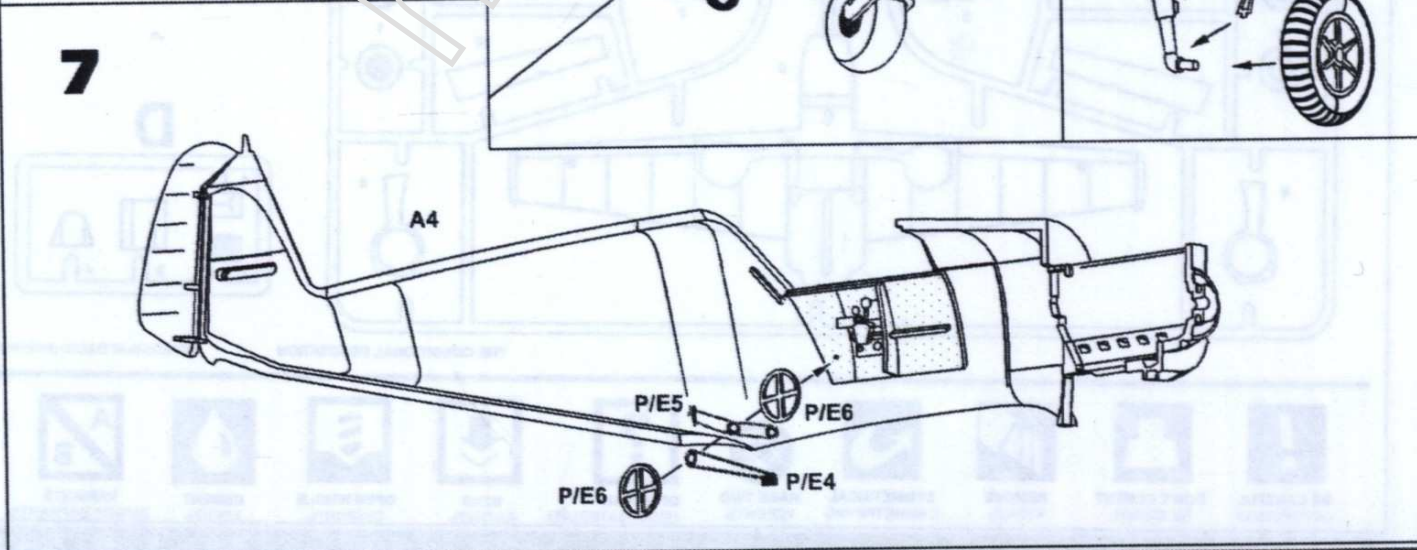
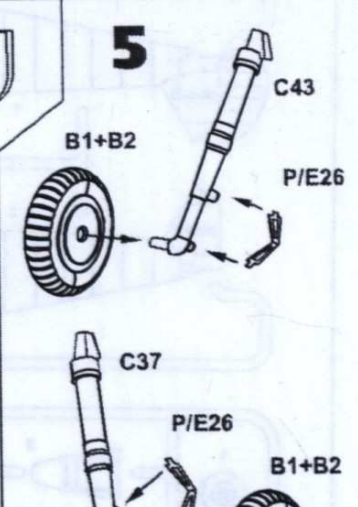
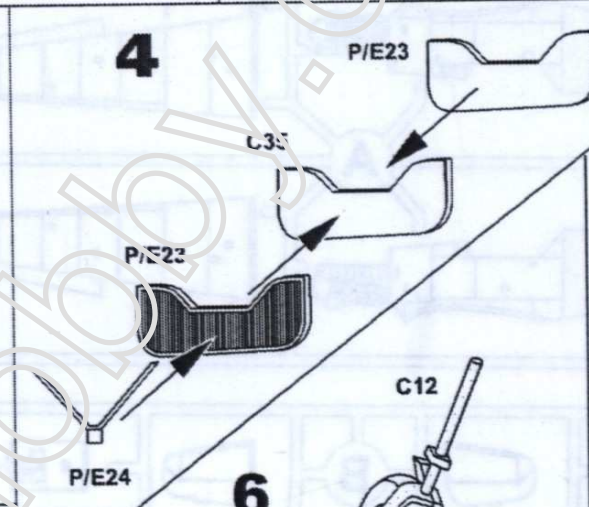
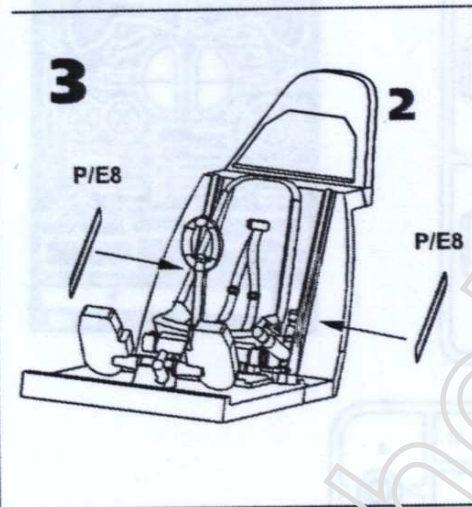
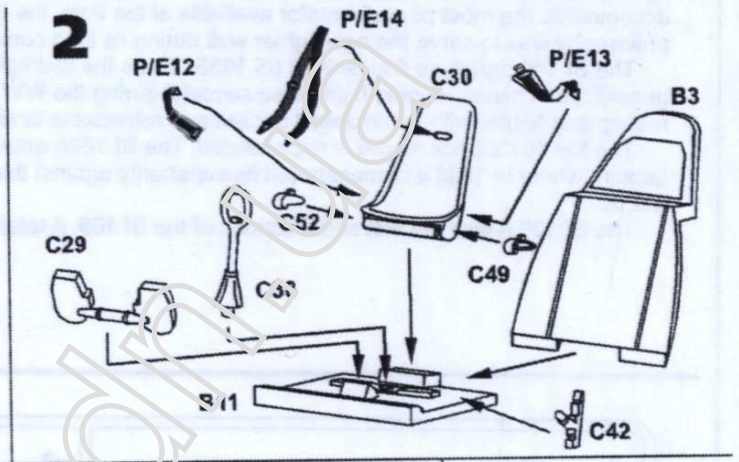
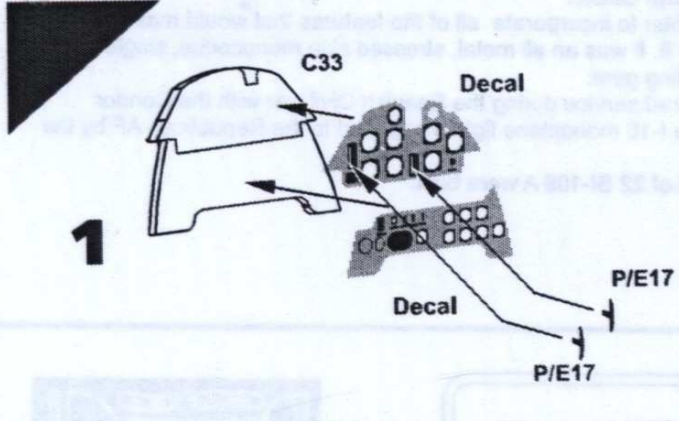



8

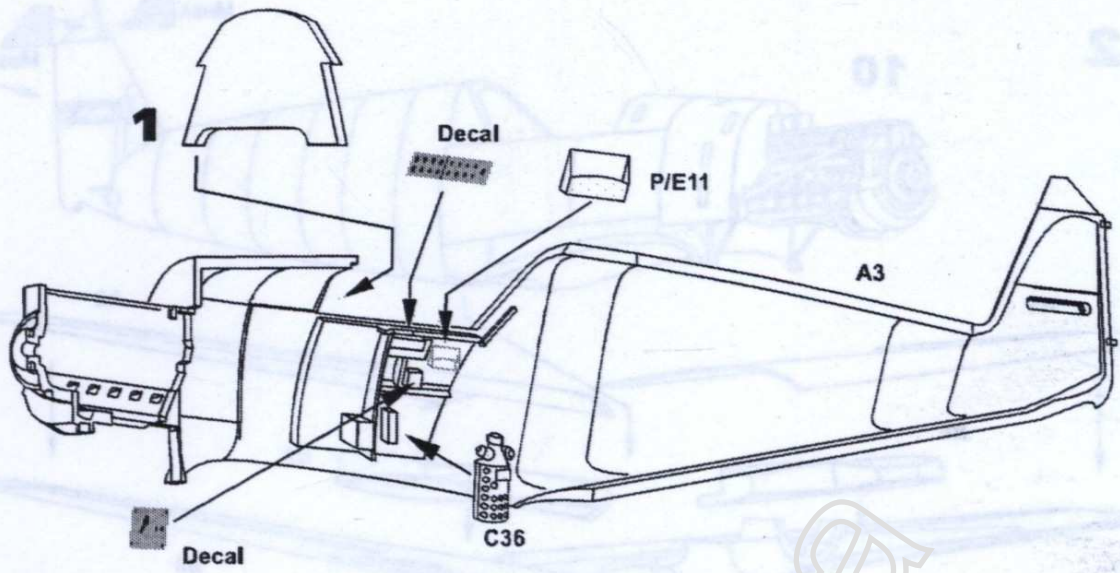

9

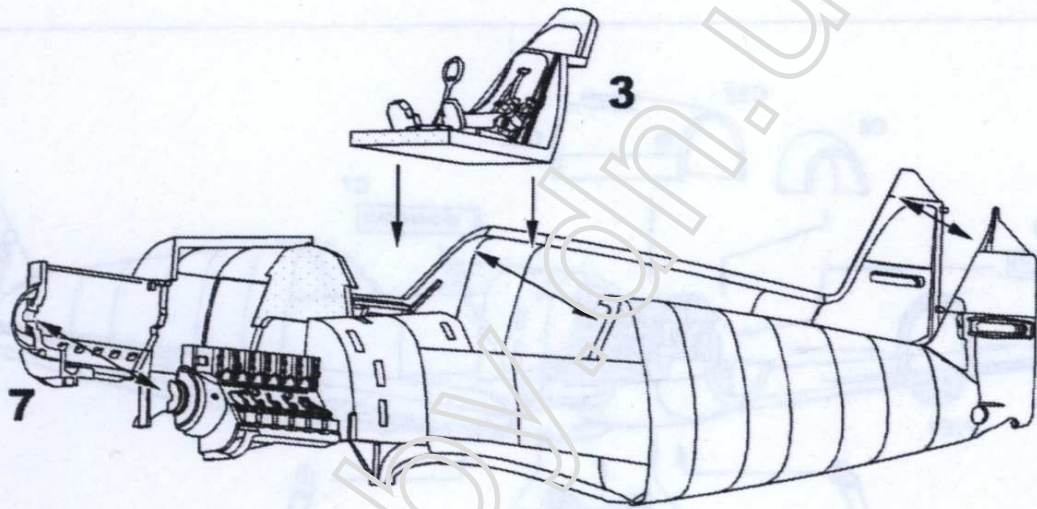

10

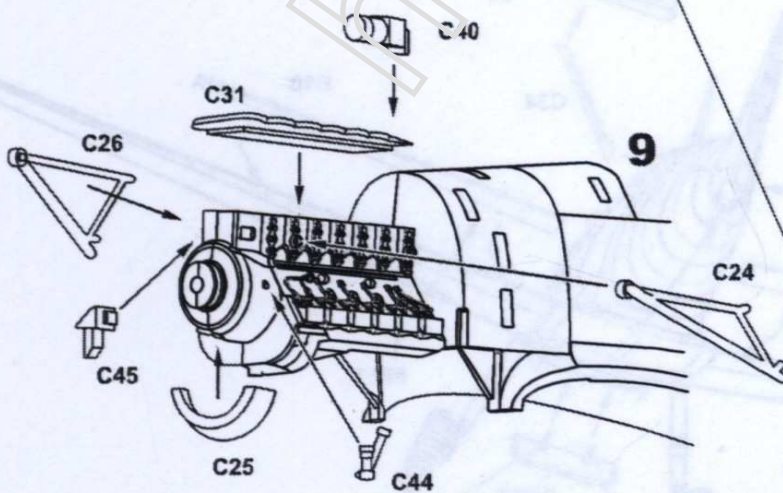

11

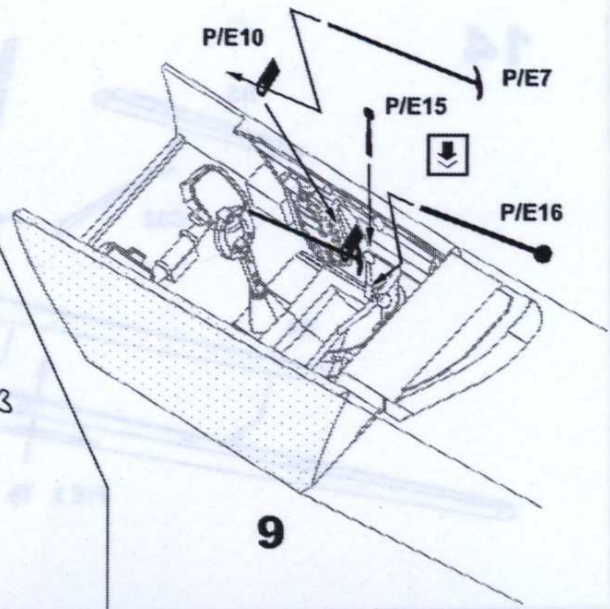



12

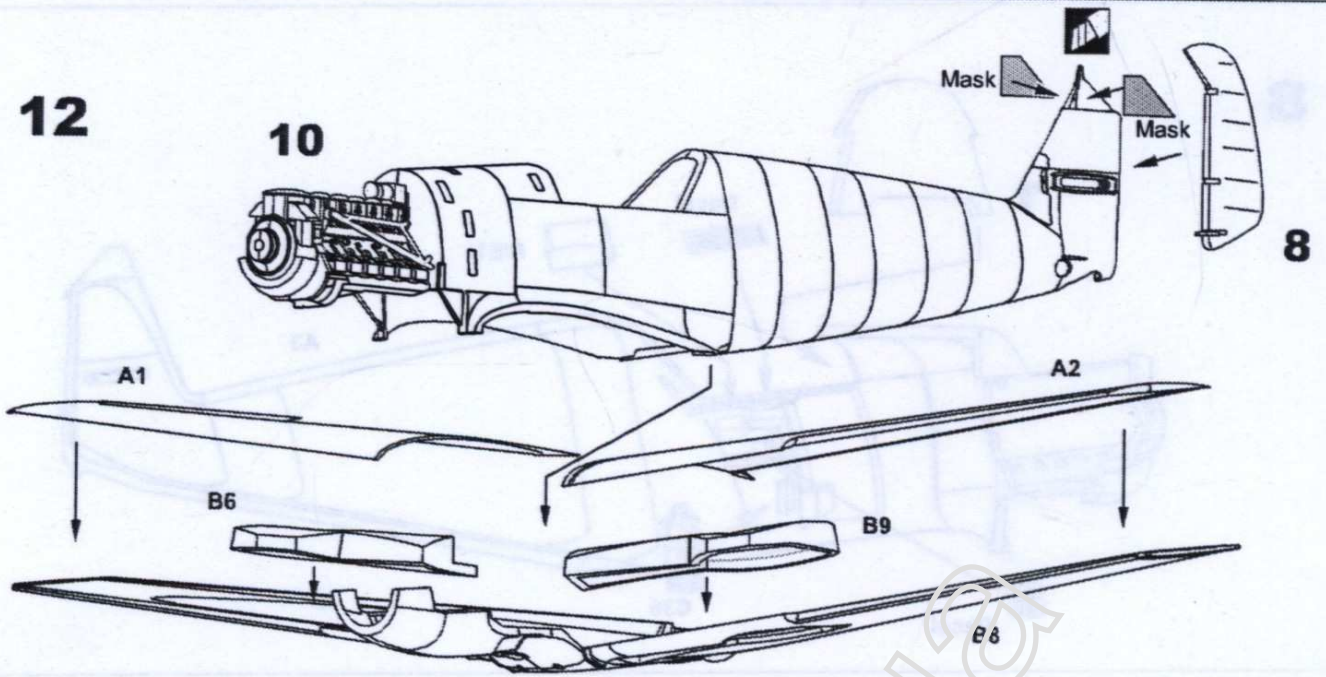

13

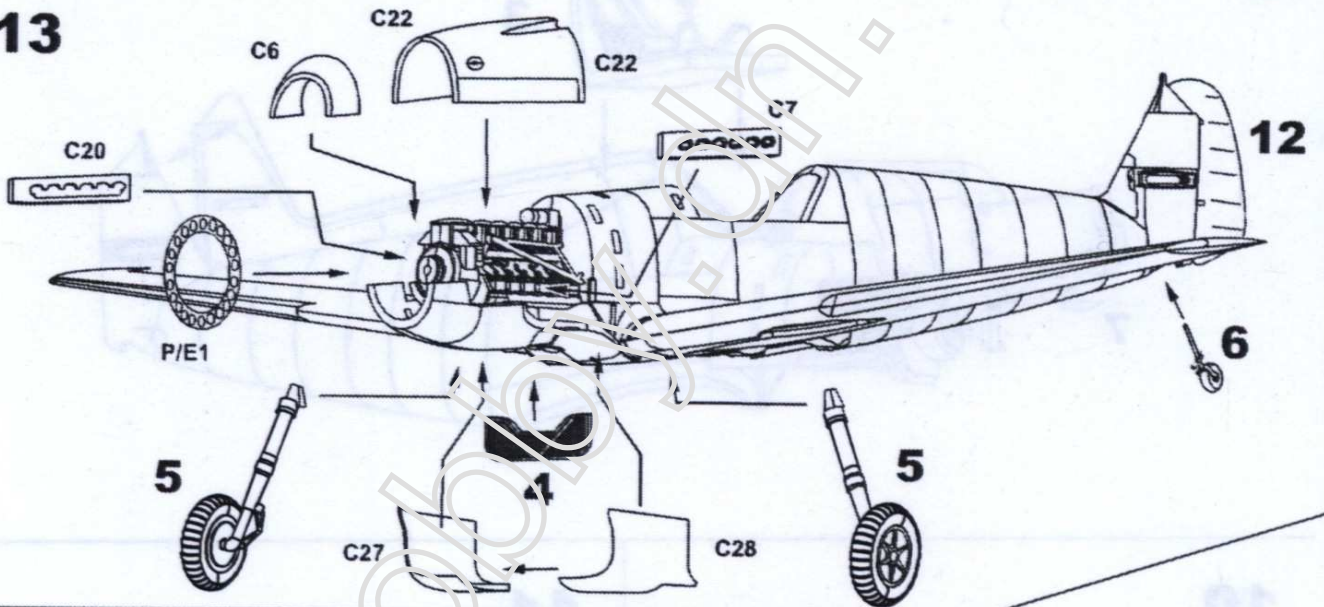

14

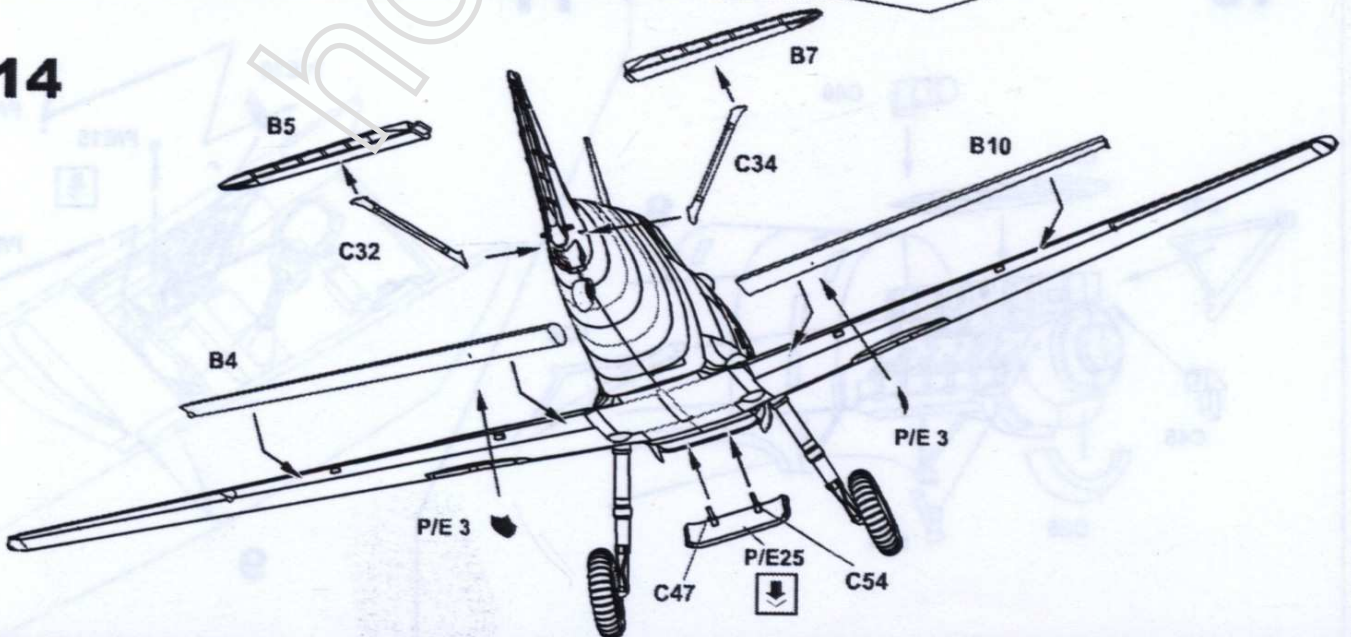



15

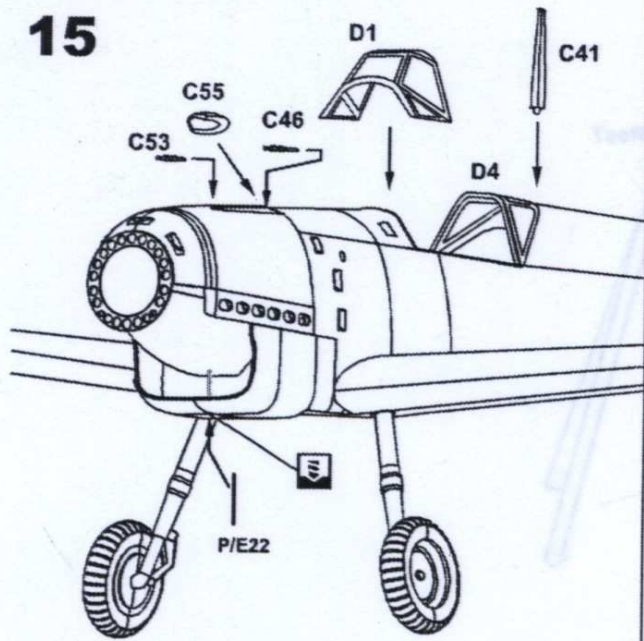

16

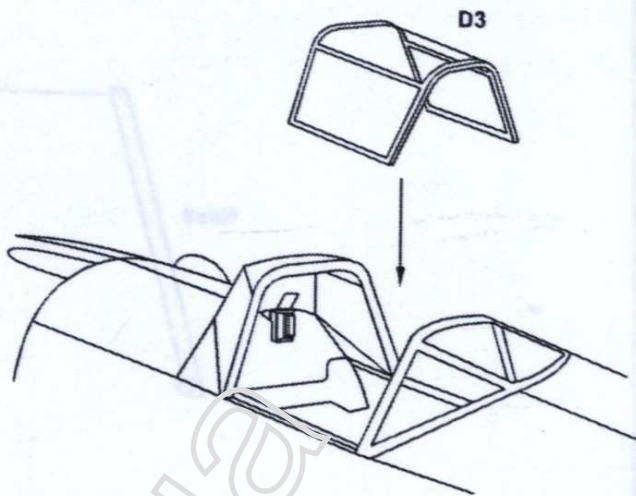

17

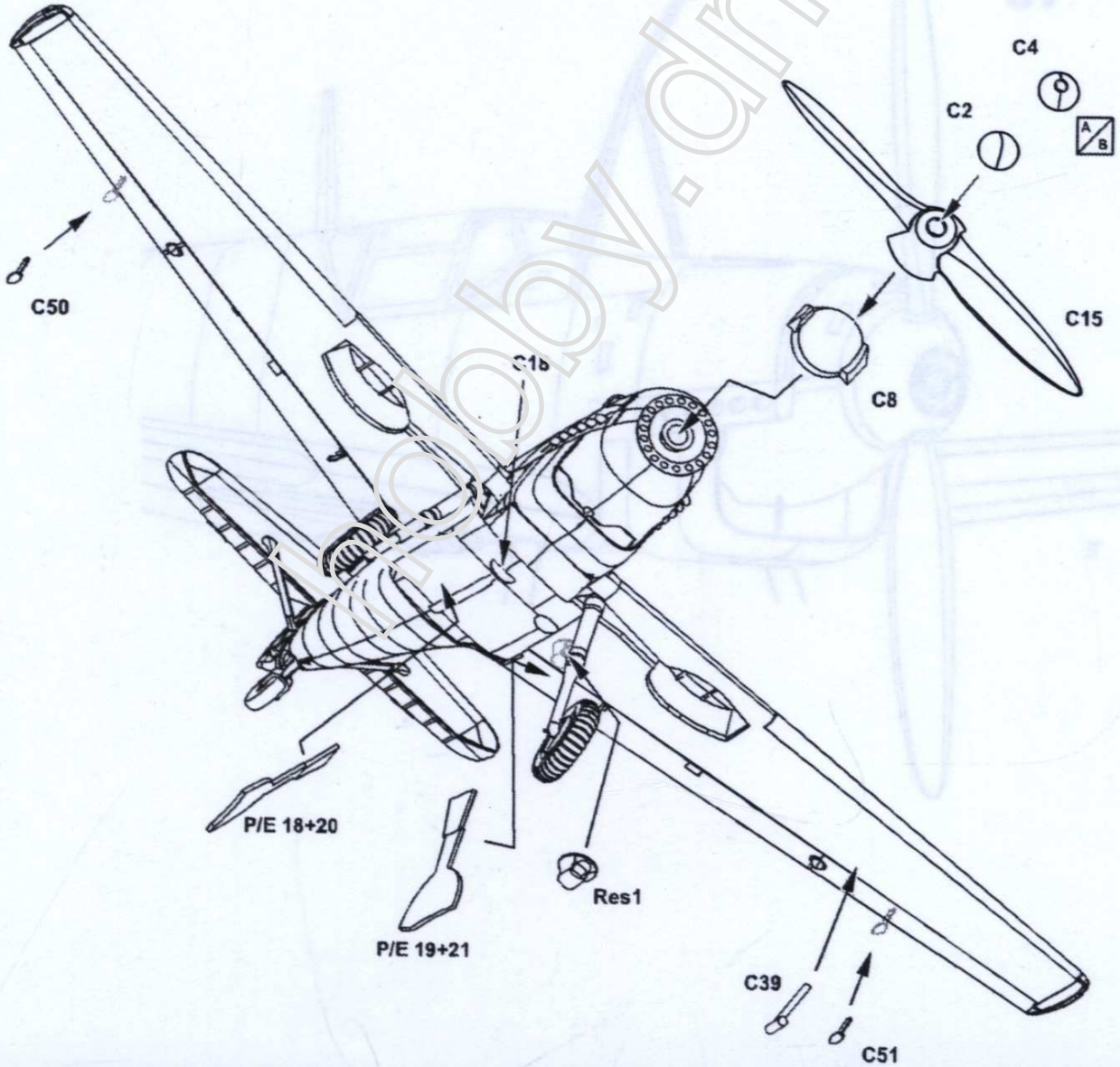

18

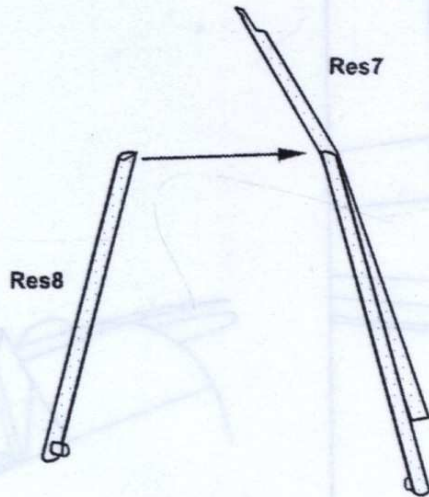

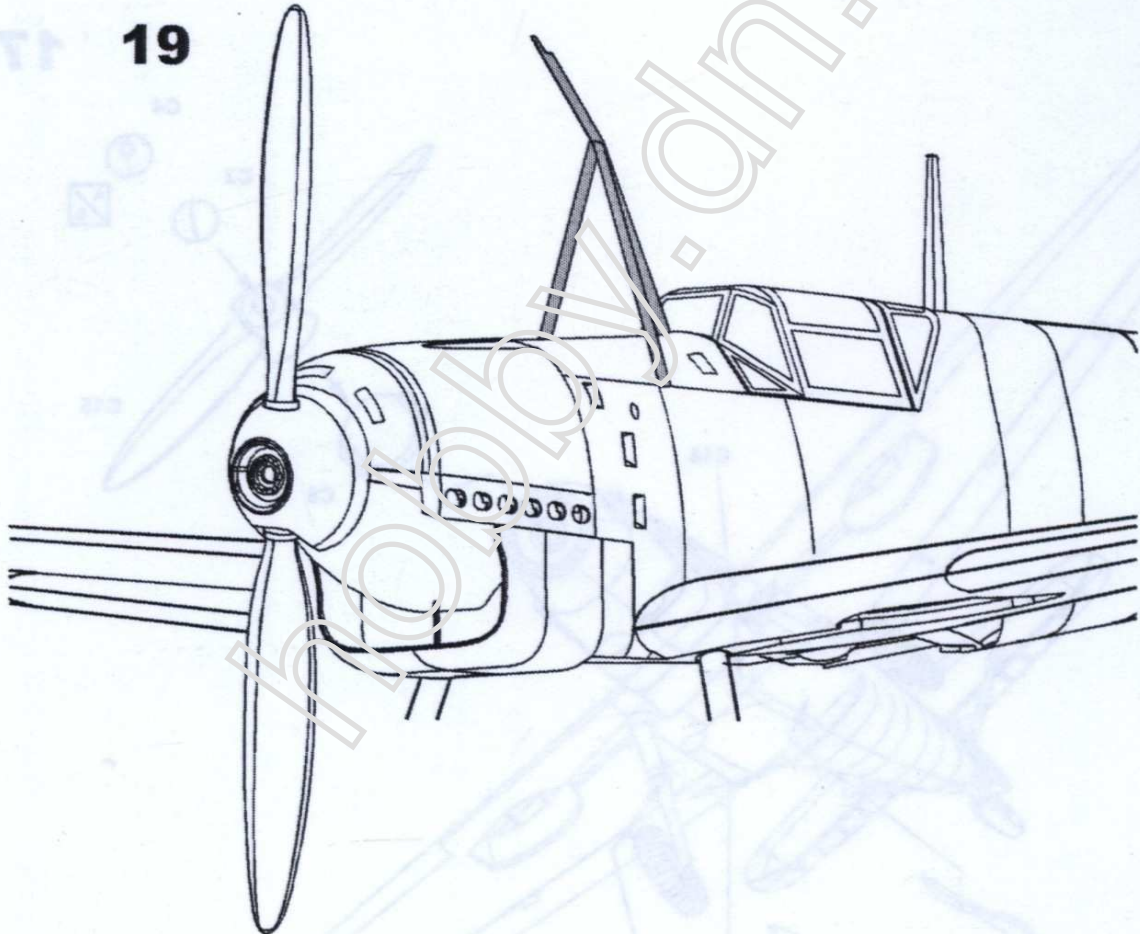

19



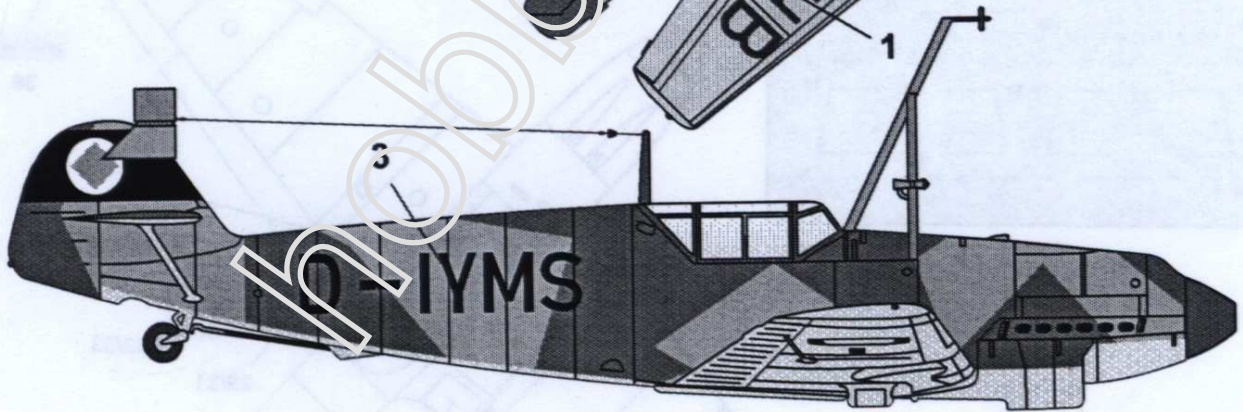
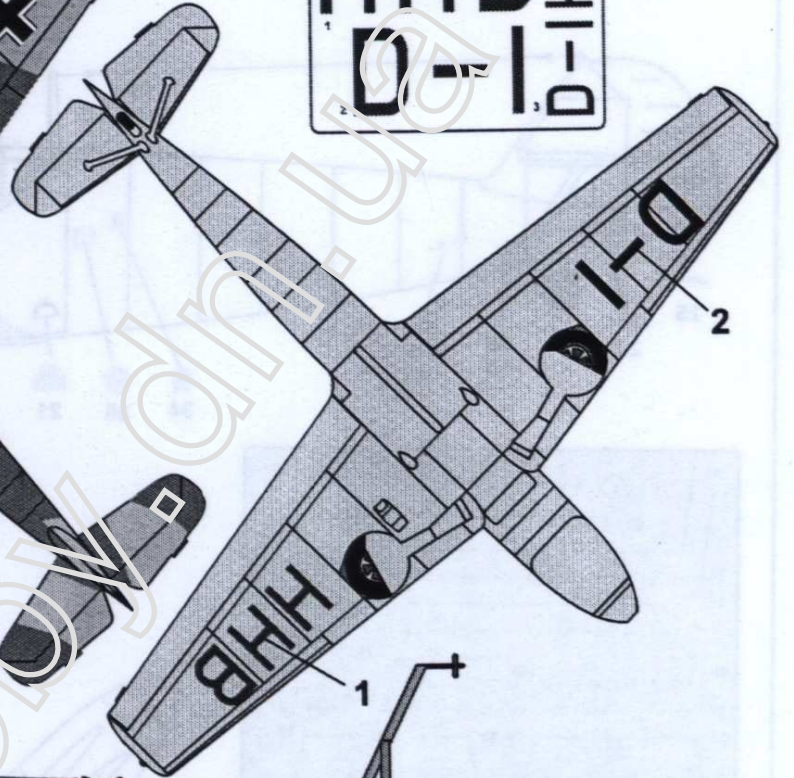
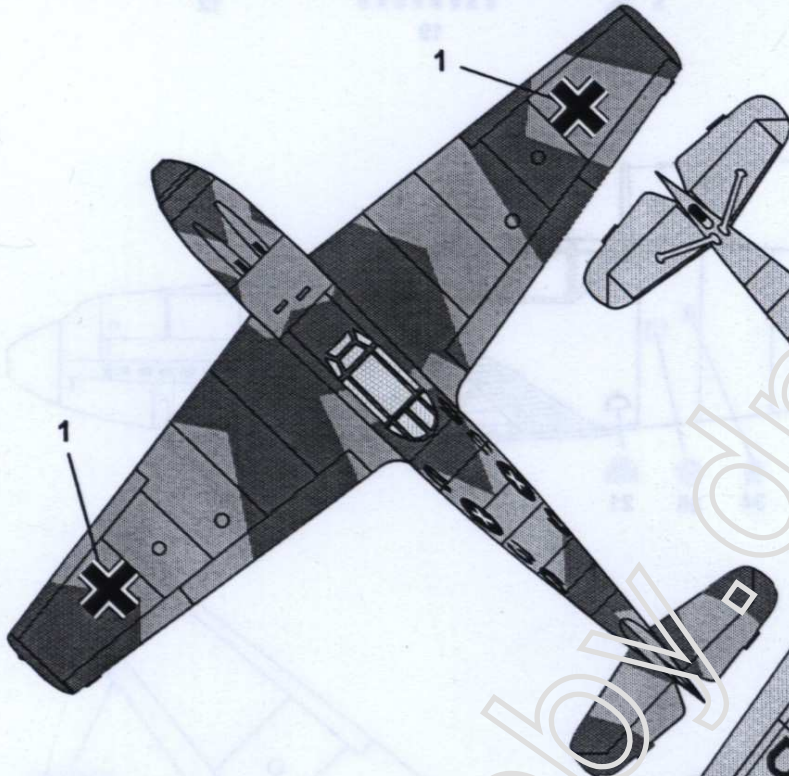
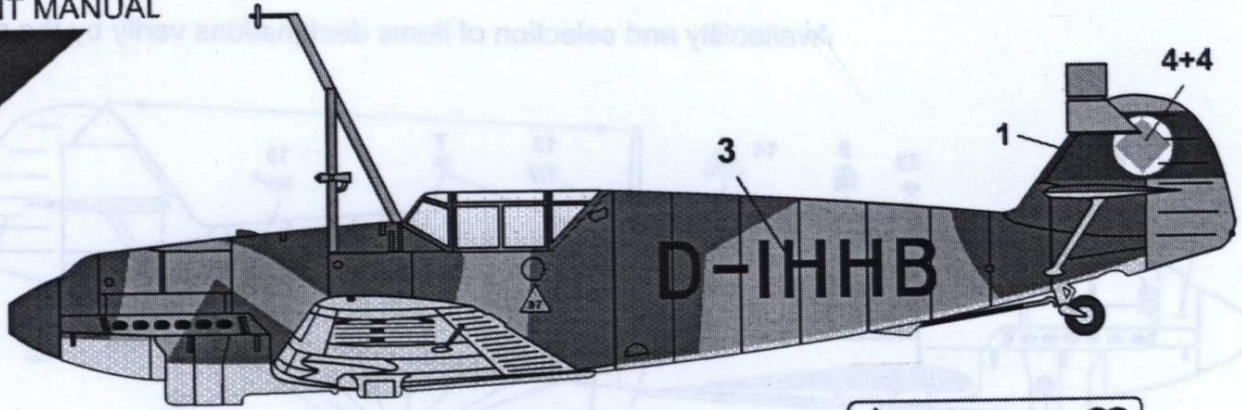



RLM 70 

RLM 71 

RLM 62 

(D-IHHB) : Messerschmitt Bf.109 V.6/B-0, Sept 16th. 1939, Germany



Availability and selection of items designations verify by the photos!

