



# Polikarpov R-5

The R-5 was a biplane reconnaissance and light bomber that was produced in vast numbers in the Soviet Union in the pre-war years.

The R-5 was designed while N. Polikarpov was working as the chief designer at Moscow's №25 factory. It was designed to be simple to fly, have a long life and be of wooden construction. It was designed around the BMW VI inline engine, which then entered licence production in the SU as the M-17.

The R-5 became the standard reconnaissance, bomber and attack aircraft with the SU AF, being used in large numbers, with over 100 air regiments equipped with the R-5. This aircraft took active part in the Nomonhan Incident, Soviet invasion of Poland and Winter War against Finland. They remained in service during the war against Germany in 1941-45, where they were mainly used as night bombers and liaison aircraft, serving until 1945!

Eventually 7,000 aircraft were built over seven (1930-1936) years.

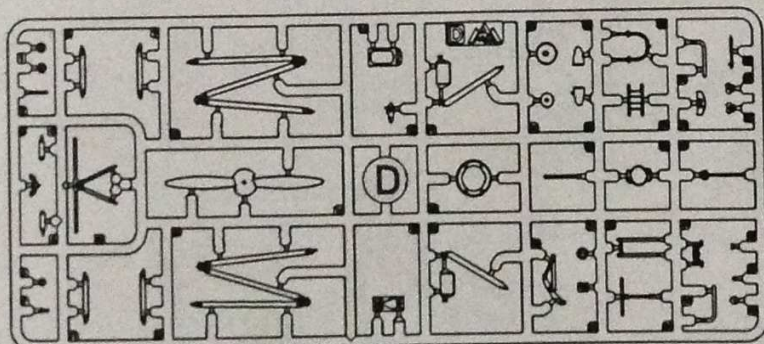
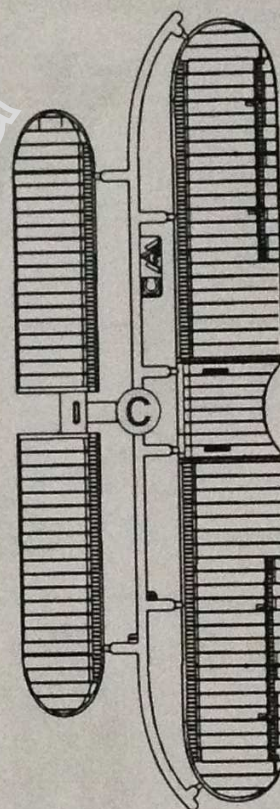
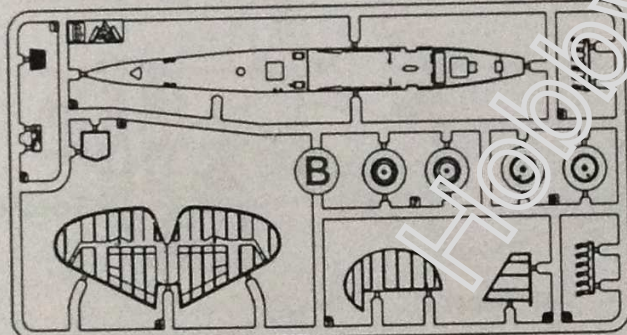
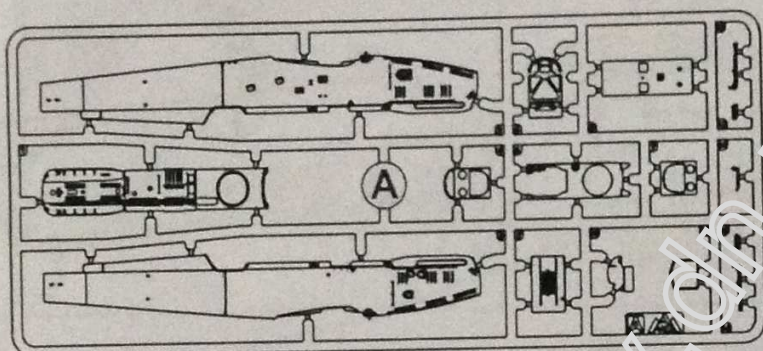

Wire



Film

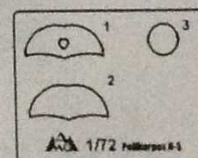

THE CONDITIONAL DENOTATION

УСЛОВНЫЕ ОБОЗНАЧЕНИЯ



BE CAREFUL  
ОСТОРОЖНО



DONT CEMENT  
НЕ КЛЕИТЬ



REMOVE  
УДАЛИТЬ



SYMMETRICAL  
СИММЕТРИЧНО



MAKE TWO  
УДОБИТЬ



OPTIONAL  
НЕОБЯЗАТЕЛЬНО



BEND  
СОГНУТЬ



OPEN WHOLE  
СЕРПНТЬ



CEMENT  
КЛЕИТЬ



VARIANTS  
ВЕРСИИ ВАРИАНТА

ASSEMBLY MANUAL

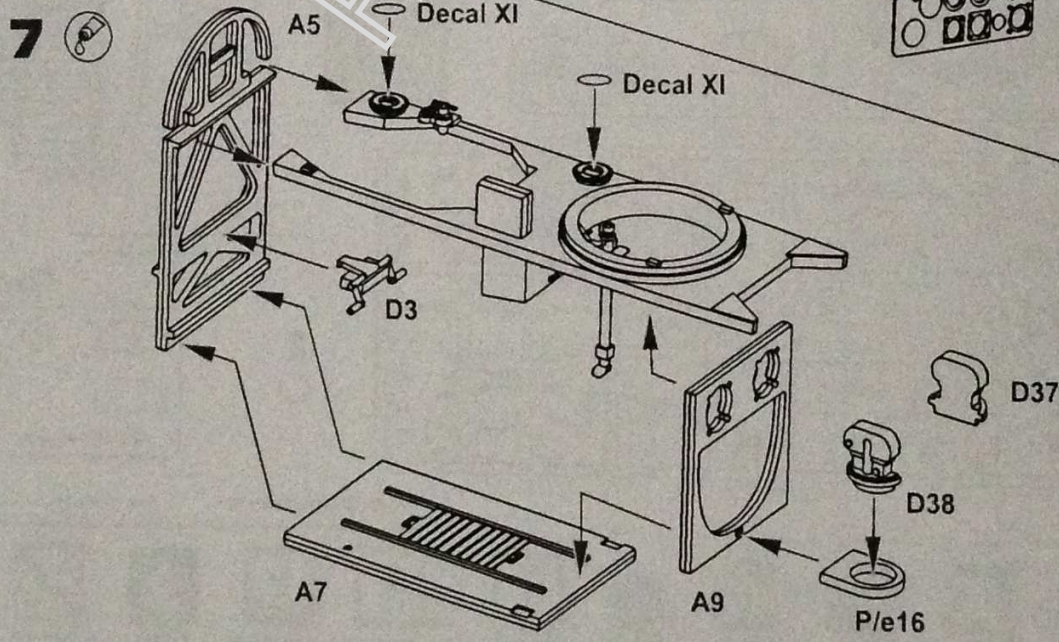
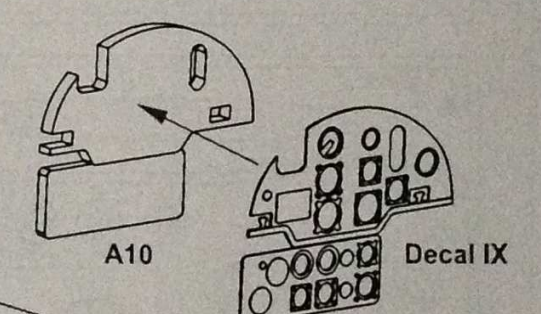
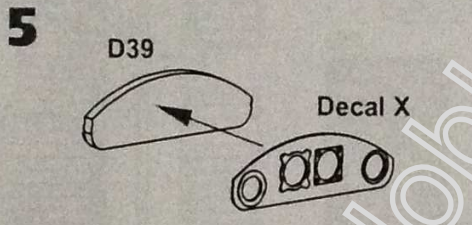
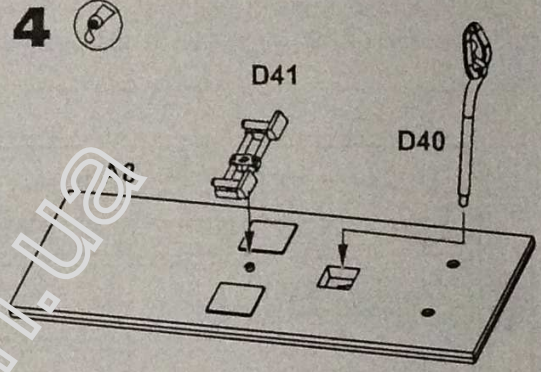
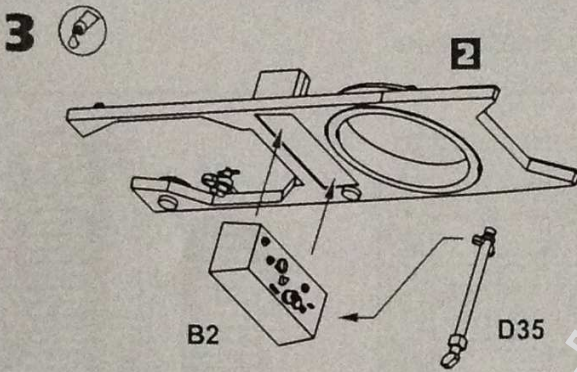
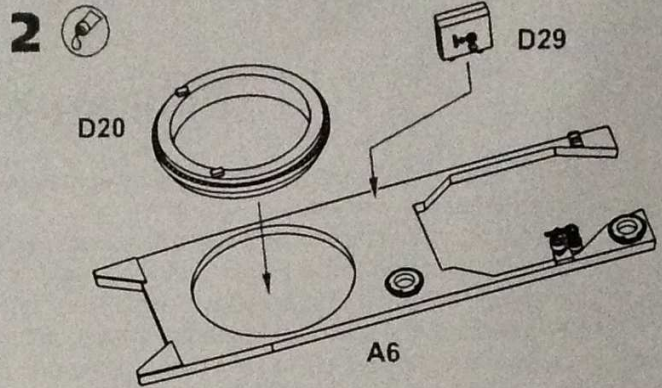
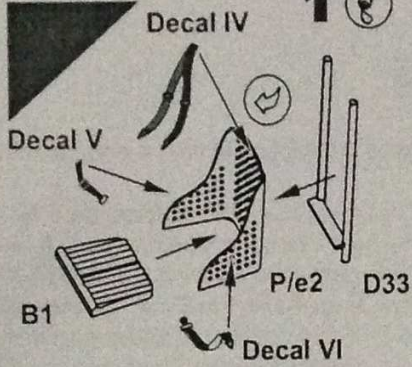

8

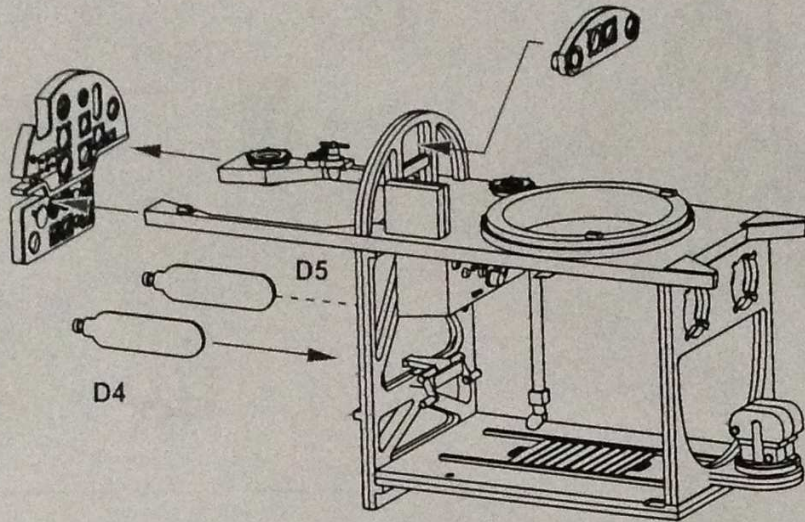

9

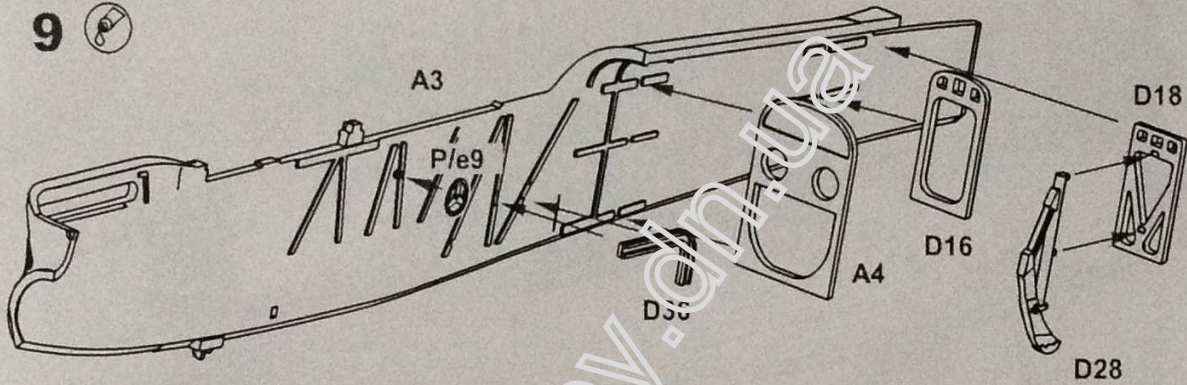

10

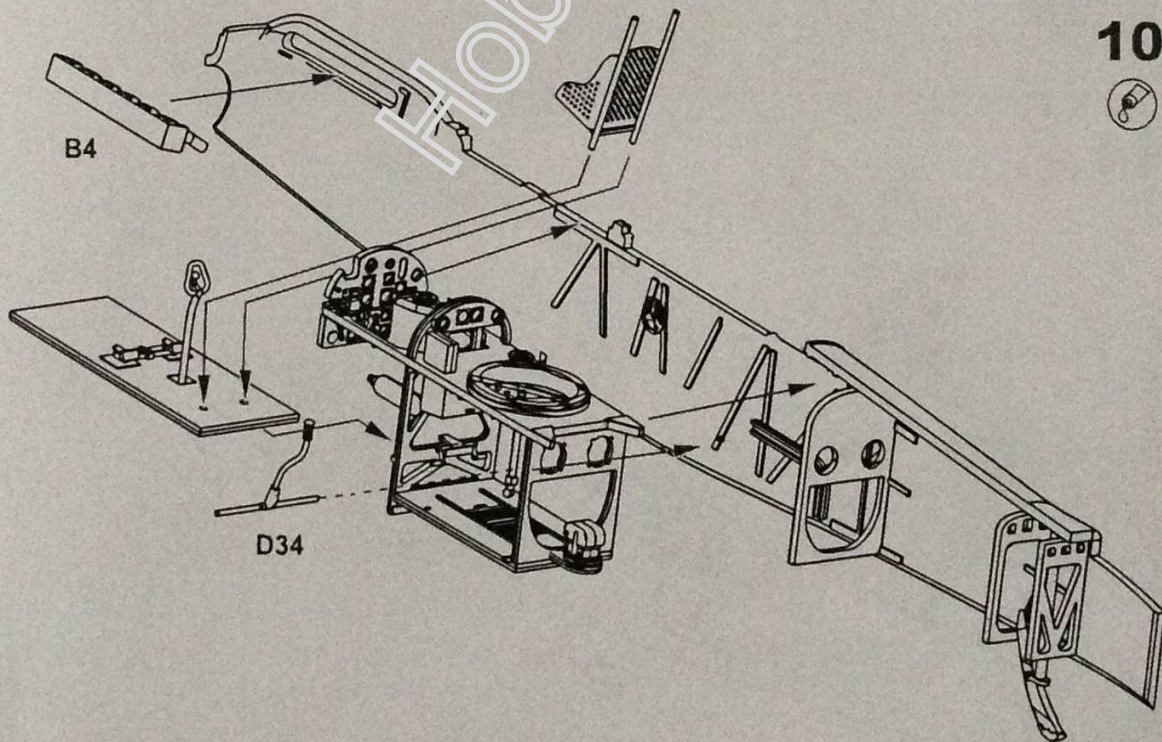

11

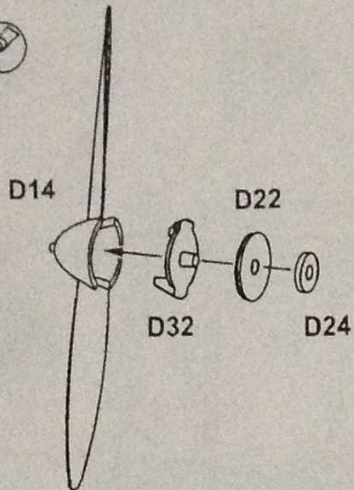

12

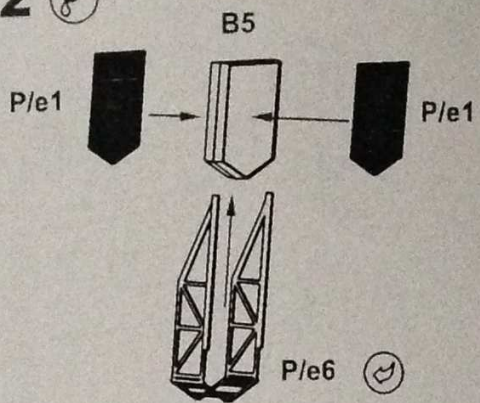

13

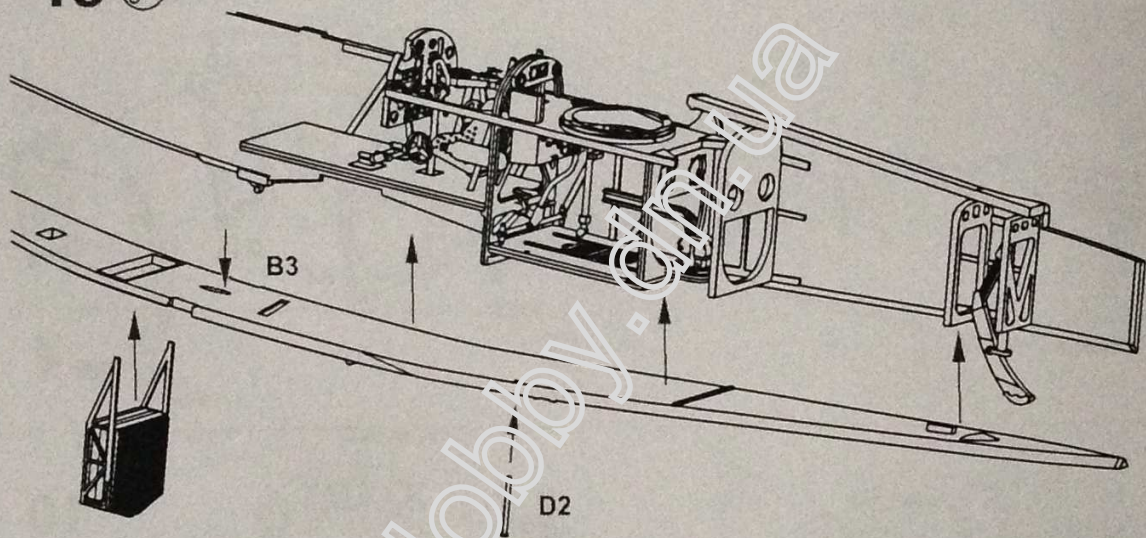

14

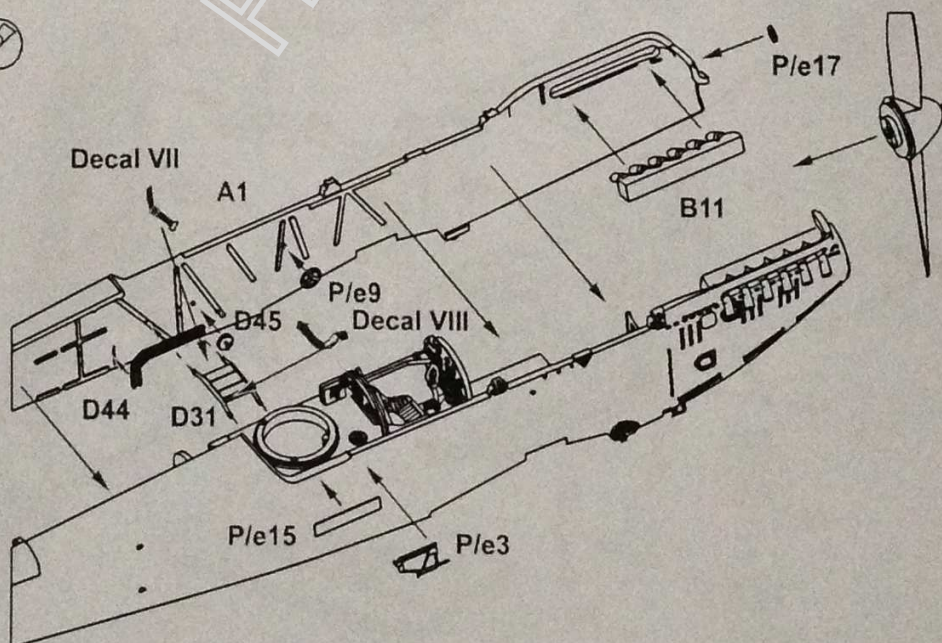

15

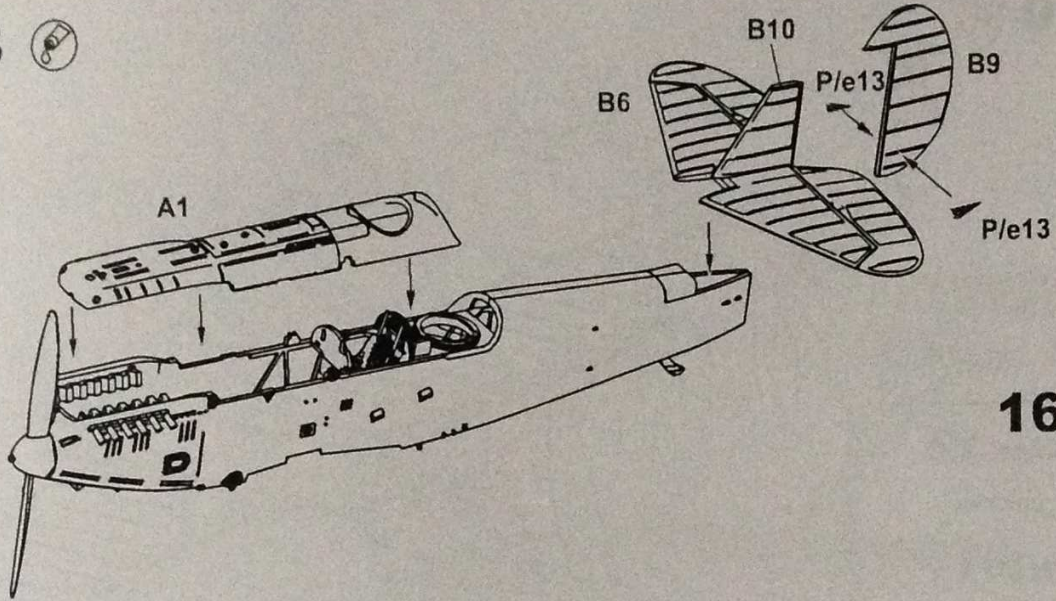

16

17

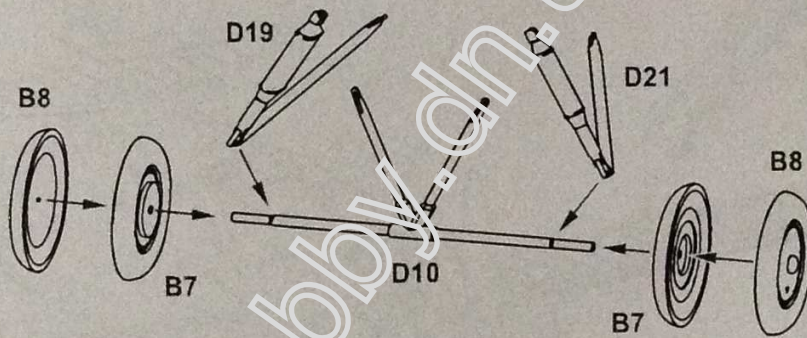

18

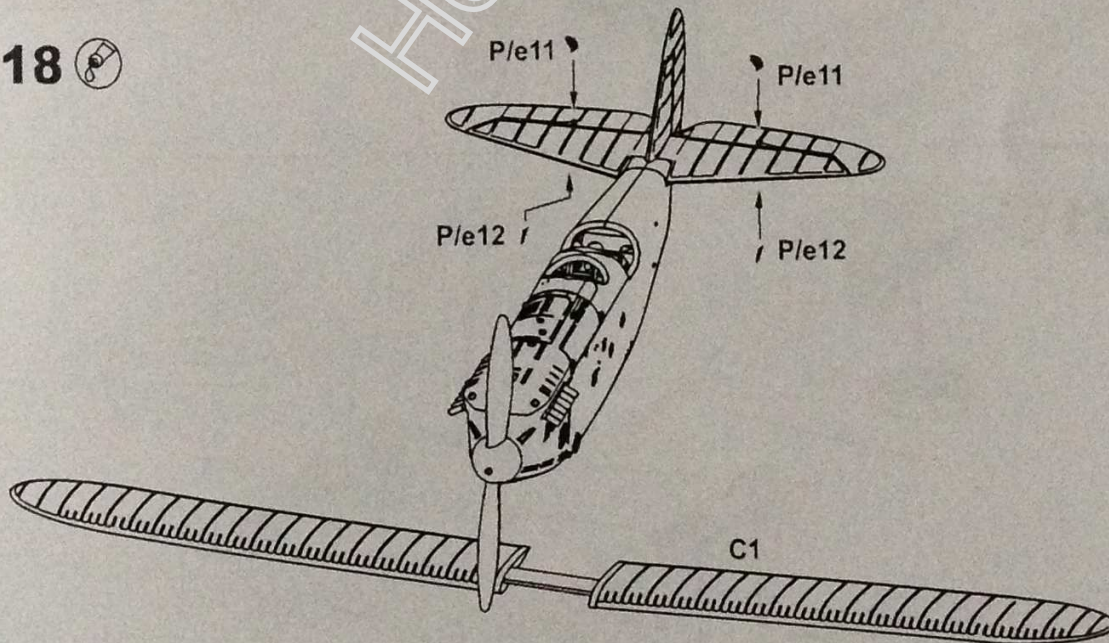

19

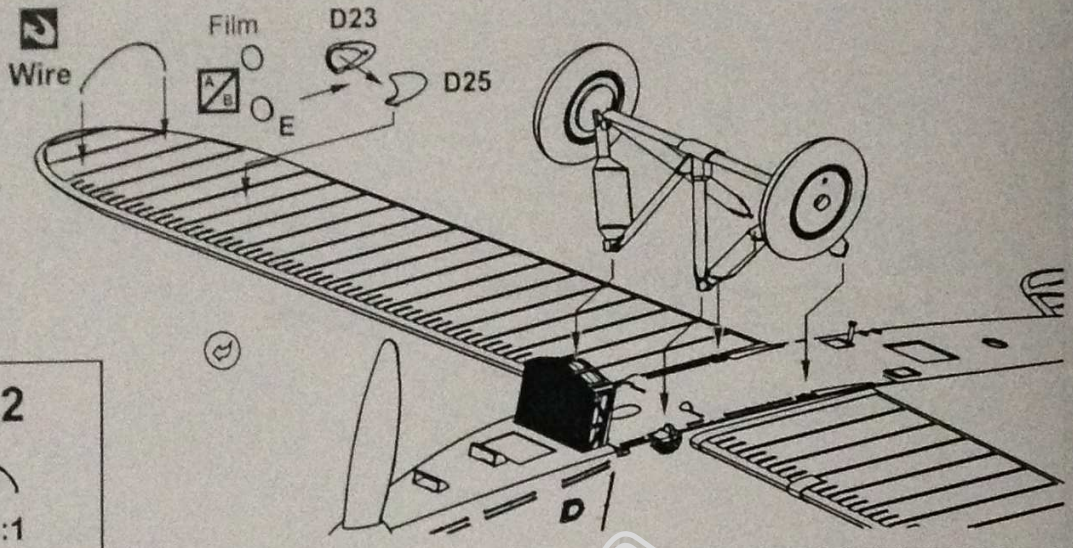

Wire X2

Scale 1:1

20

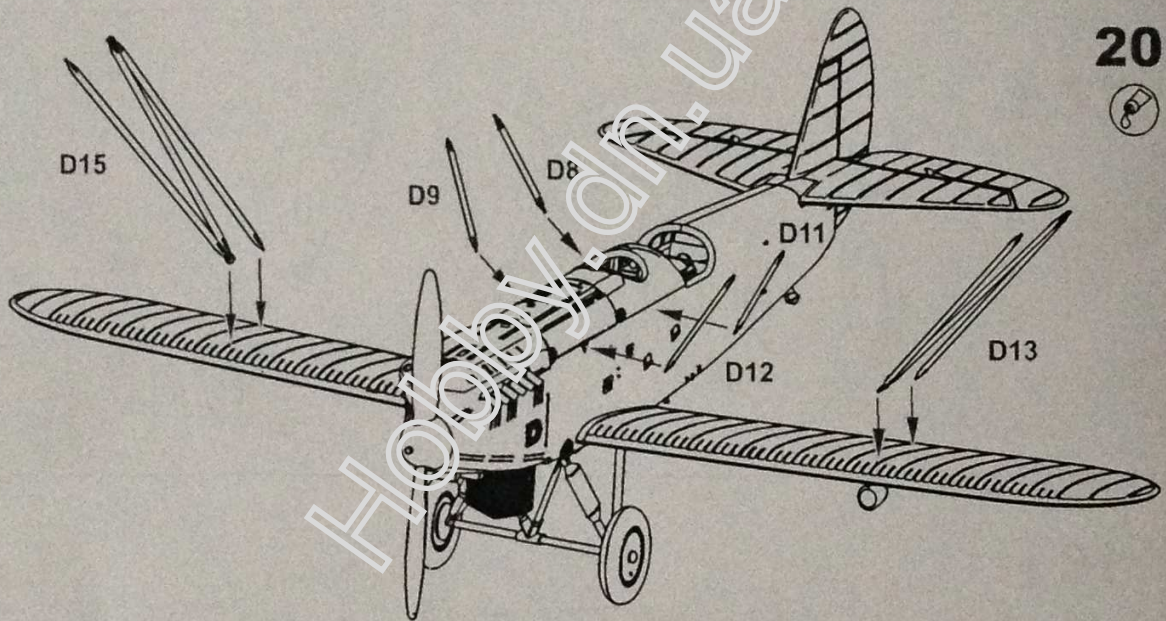

21

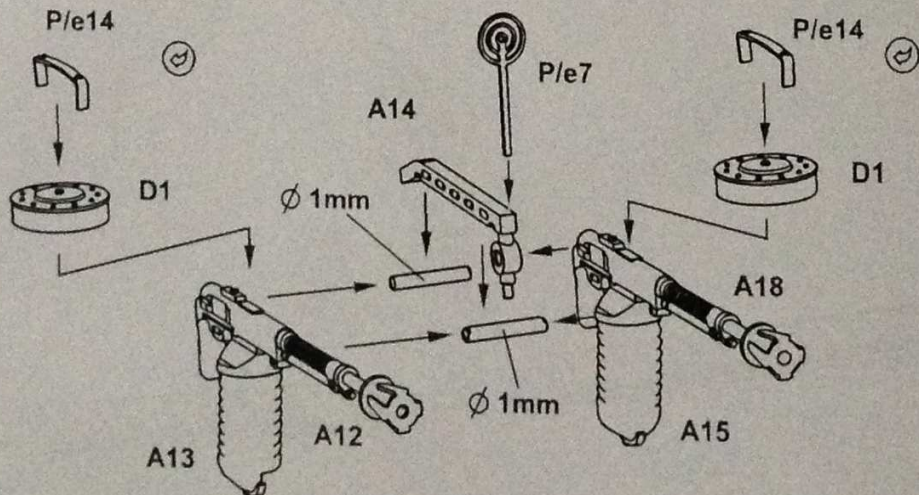

22

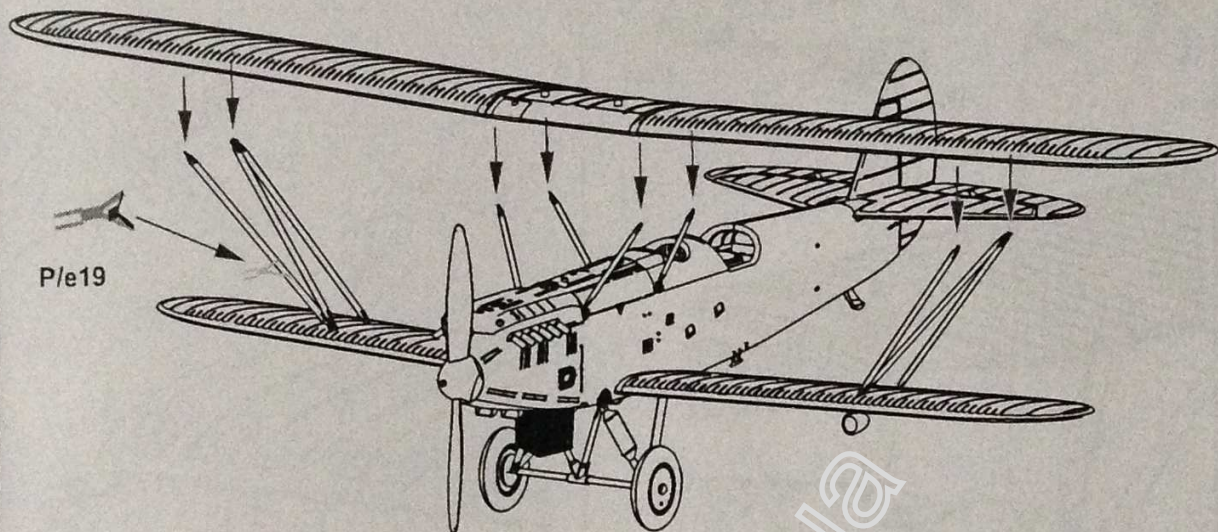

23

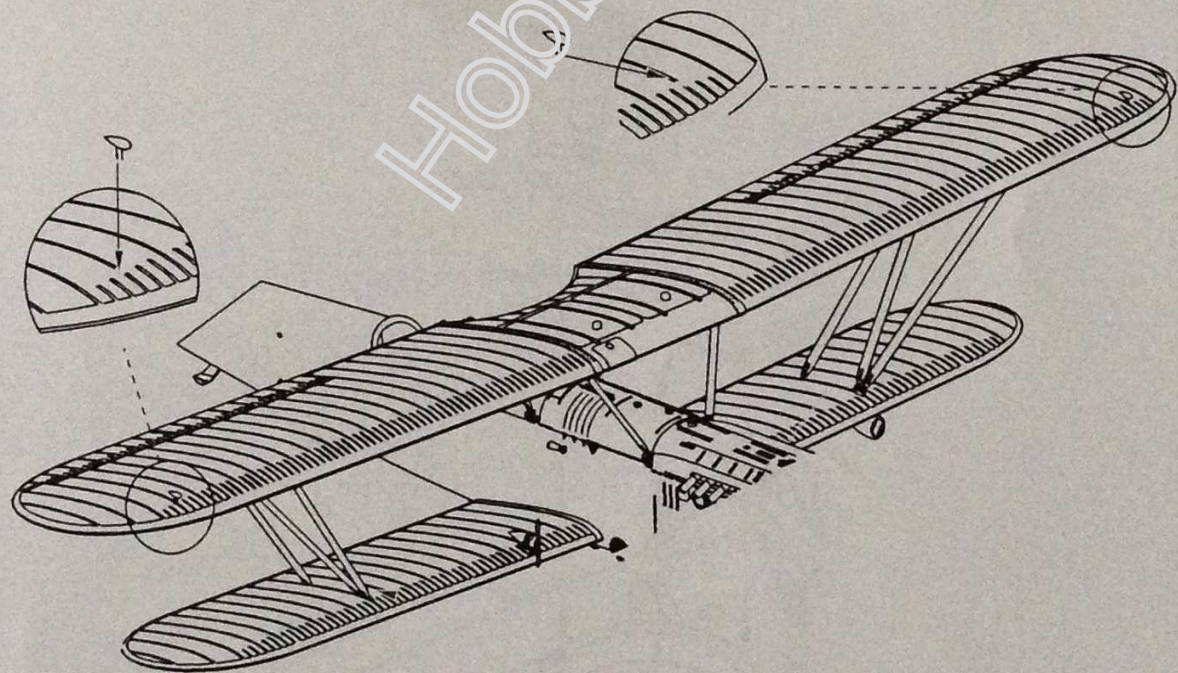

24

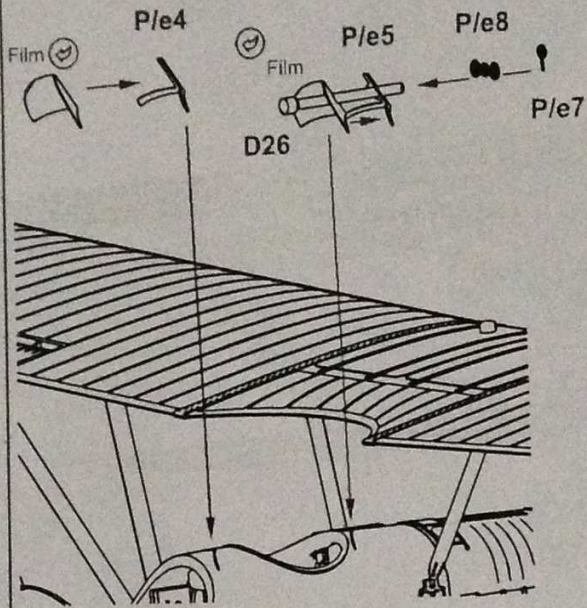

25

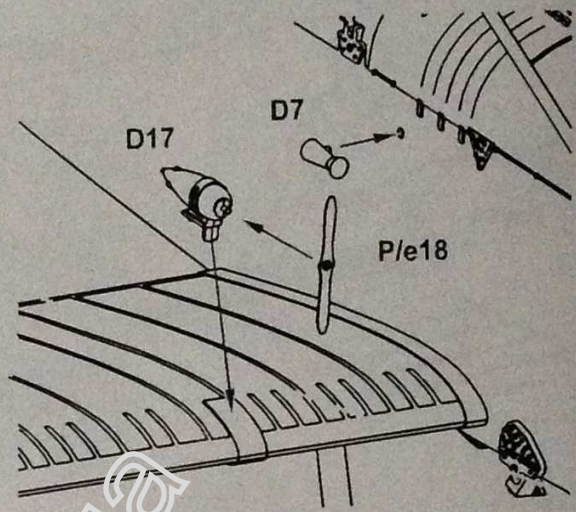

26

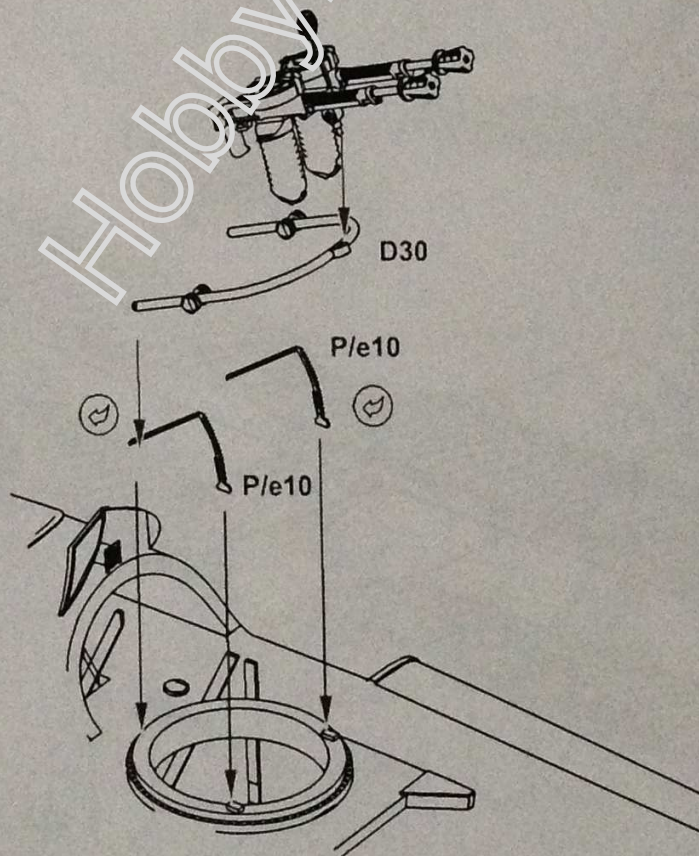



PAINT MANUAL

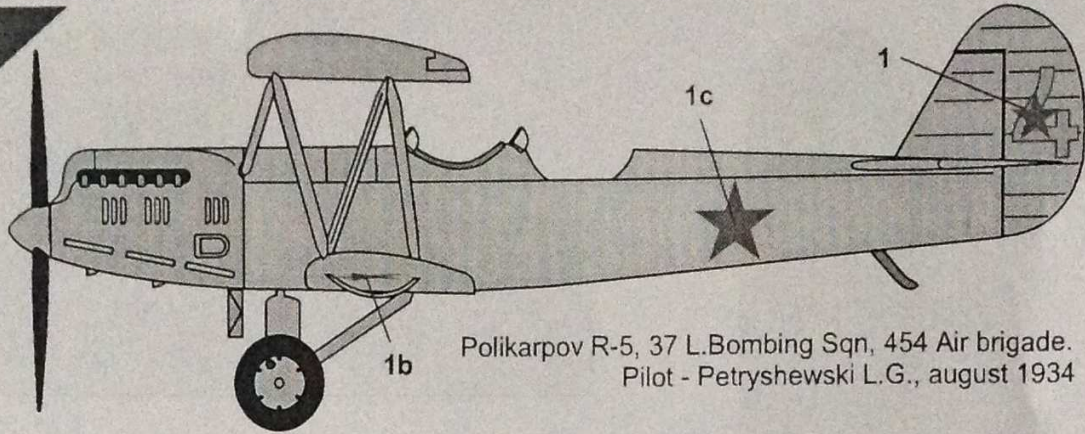

Polikarpov R-5, 37 L.Bombing Sqn, 454 Air brigade.  
Pilot - Petryshewski L.G., august 1934

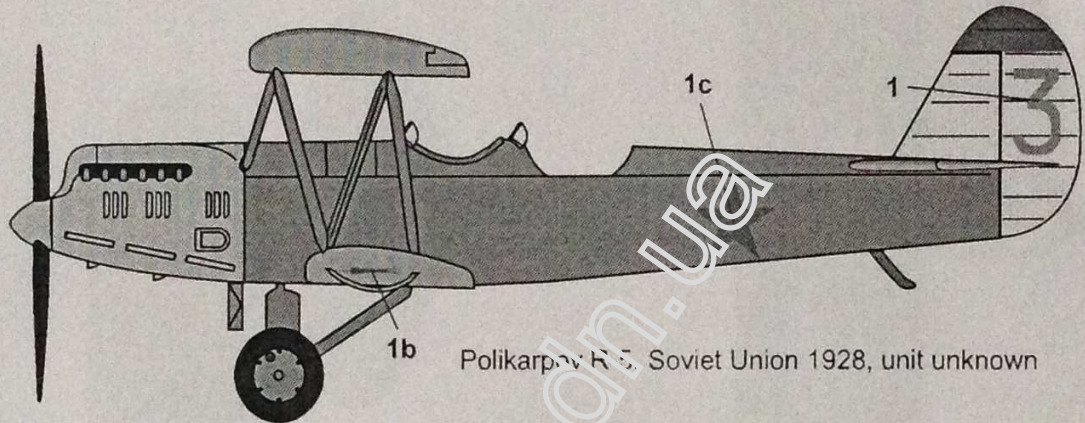

Polikarpov R-5, Soviet Union 1928, unit unknown

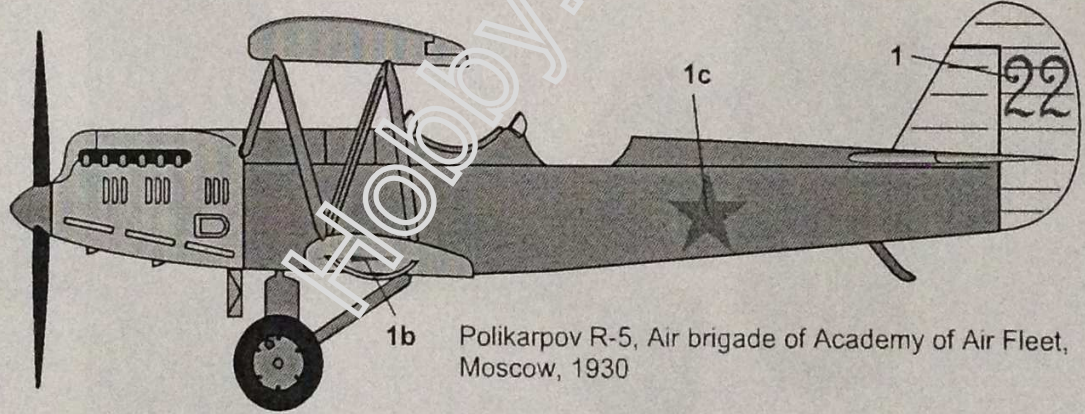

Polikarpov R-5, Air brigade of Academy of Air Fleet,  
Moscow, 1930

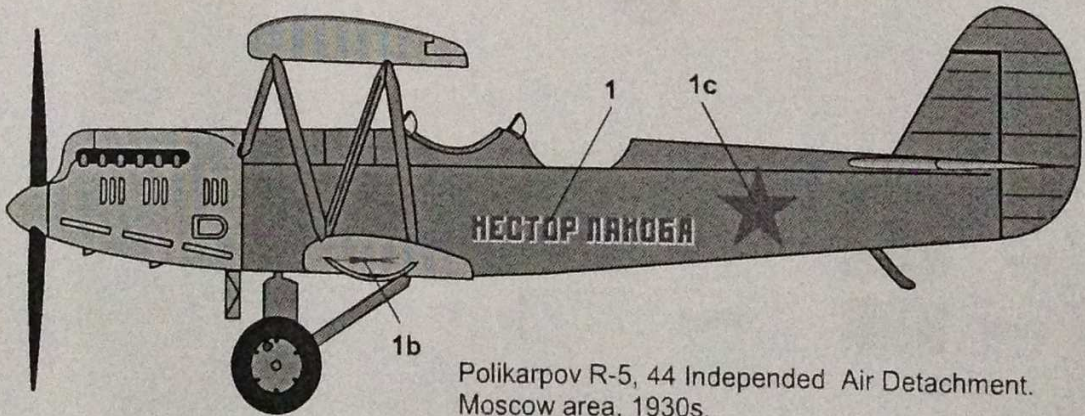



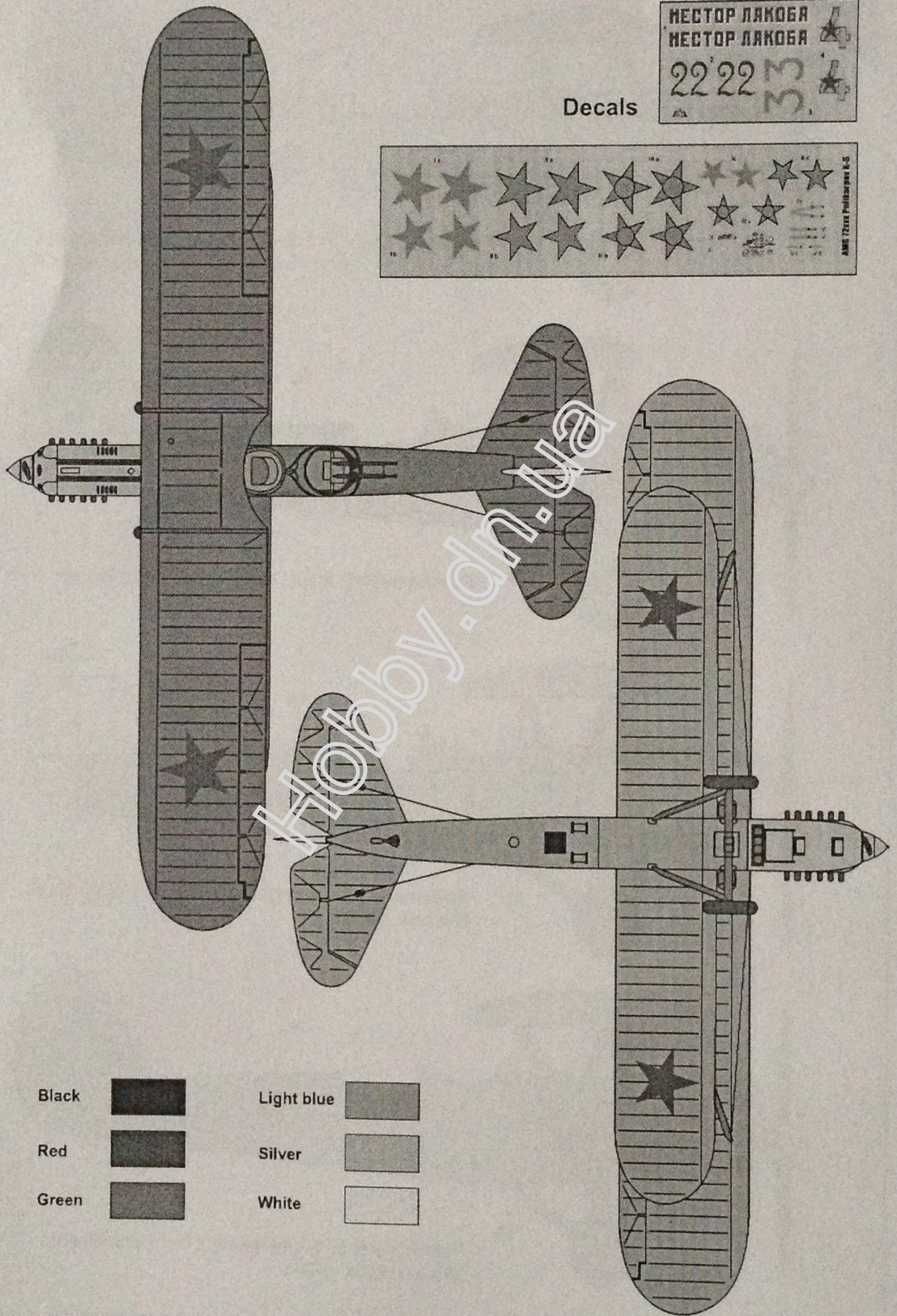



Polikarpov R-5, 44 Independent Air Detachment.  
Moscow area, 1930s.

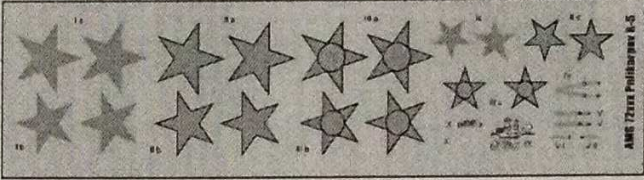

НЕСТОР ЛЯКОВА  
 НЕСТОР ЛЯКОВА  
 22 22 M M  
 M

Decals

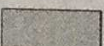

- |       |   |            |   |
|-------|---|------------|---|
| Black |  | Light blue |  |
| Red   |  | Silver     |  |
| Green |  | White      |  |