

AMK
AvantGarde Model Kits



ISRAEL IAI KFIR C2/C7



1/48 UNASSEMBLED MODEL KIT

INSTRUCTIONS

“幼獅”戰鬥機 IAI KFIR C2/C7



以色列飛機工業公司“幼獅”Kfir (希伯來語: קפיר) 是以色列制造的全天候多用途作戰飛機，改良自法國達索公司幻影5的機身基礎上，“幼獅”加裝了以色列的航空電子設備和以色列的國產版通用電氣J79渦扇噴射發動機。

“幼獅”於1975年開始服役於以色列空軍，第一臺被分配到第101“第一戰士”中隊。在隨後的幾年中，其他幾個中隊都配備了新的飛機。於1976年第一架F-15鷹式戰鬥機從美國交付到以色列后，“幼獅”作為以色列空軍主要空中優勢戰鬥機的短暫任務周期就結束了。

1977年11月9日，以色列空襲一個黎巴嫩游擊隊訓練營。是“幼獅”的第一個有記錄的作戰行動，“幼獅”戰鬥機的唯一空戰勝利在1979年6月27日發生，編號874的以色列空軍“幼獅”C.2擊落了一架敘利亞空軍米格-21戰鬥機。

1982年以色列與黎巴嫩戰爭(加利利和平行動)的時候，以色列空軍的F-15和F-16戰鬥機發揮了強大的空中優勢的作用，讓“幼獅”可在沒有護航的情況下進行對地打擊空襲任務。不久之后，所有以色列空軍“幼獅”C2開始升級到C7版本，增強了負重能力和對地攻擊功能，使得“幼獅”更適合執行戰鬥/轟炸的作戰任務在20世紀90年代後半期，經過近20年的作戰生涯，“幼獅”戰鬥機從以色列空軍退役。

The Israel Aircraft Industries Kfir (Hebrew: קפיר "Lion Cub") is an Israeli-built all-weather, multirole combat aircraft based on a modified Dassault Mirage 5 airframe, with Israeli avionics and an Israeli-made version of the General Electric J79 turbojet engine.

The Kfir entered service with the IAF in 1975, the first units being assigned to the 101st "First Fighter" Squadron. Over the following years, several other squadrons were also equipped with the new aircraft. The role of the Kfir as the IAF's primary air superiority asset was short-lived, as the first F-15 Eagle fighters from the United States were delivered to Israel in 1976.

The Kfir's first recorded combat action took place on November 9, 1977, during an Israeli air strike on a training camp at Tel Azia, in Lebanon. The only air victory claimed by a Kfir during its service with the IAF occurred on June 27, 1979 when a Kfir C2 shot down a Syrian MiG-21.

During the Israeli-Lebanon war in 1982 (Operation Peace for Galilee). The IAF was able to use both its F-15s and F-16s for air superiority roles, leaving the Kfirs to carry out unescorted strike missions. Shortly afterwards, all IAF C2s began to be upgraded to the C7 version, with enhanced weight performance, making the Kfirs more suitable to its new fighter-bomber role. During the second half of the 1990s, the Kfirs were withdrawn from active duty in the IAF, after almost twenty years of continuous service.



注意事項 / CAUTION



產品不適合8歲以下的兒童。
產品中含有帶尖點的小零件
對於3歲以下兒童當心因塞鼻產生的危害。

NOT SUITABLE FOR CHILDREN UNDER 8 YEARS.
CONTAINS FUNCTIONAL SHARP POINTS CONTAINS SMALL PARTS.
BEWARE OF CHOKING HAZARD OF CHILDREN UNDER 3 YEARS.

PAINT AND COLOR USED

1 白色 White	33 啞黑色 Flat Black	307 灰色/Gray (FS 36320)
3 紅色 Red	47 透明紅 Clear Red	308 淺灰色/Gray (FS 36375)
4 黃色 Yellow	50 透明藍 Clear Blue	310 棕啡色/Brown (FS 30219)
8 銀色 Silver	54 卡其綠色 Khaki Green	312 綠色/Green (FS 34227)
12 橄欖色 Olive Drab	61 燒鐵色 Burnt Iron	313 沙漠黃色/Sand Yellow (FS 33531)
20 淺藍色 Light Blue	73 飛機灰色 Aircraft Gray	314 淺綠色/Light Green (FS 35622)
28 黑鐵色 Steel	137 車鈦黑 Tire Black	316 白色/White (FS 17875)

1 駕駛艙
Cockpit

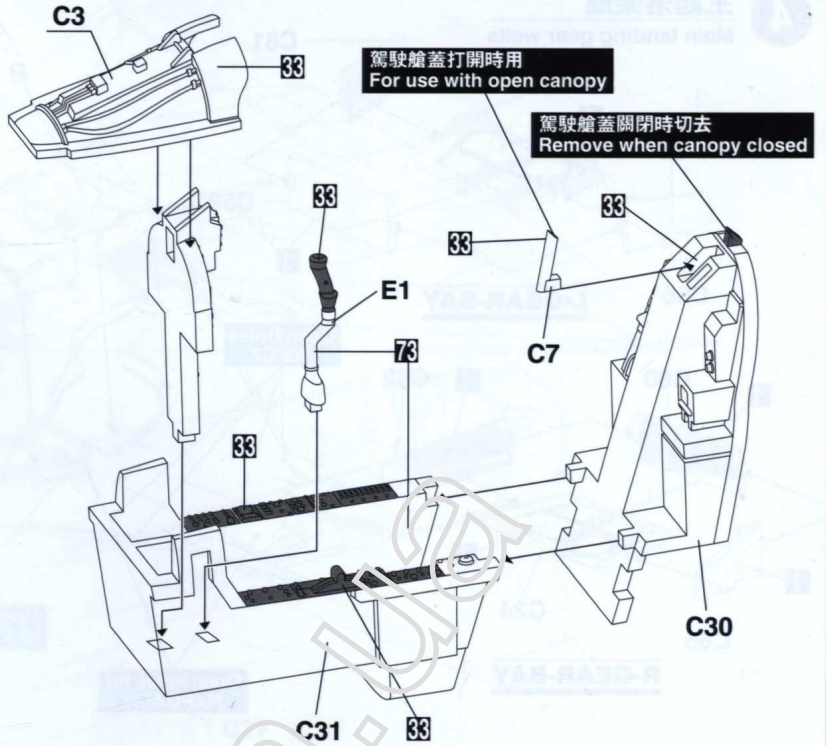
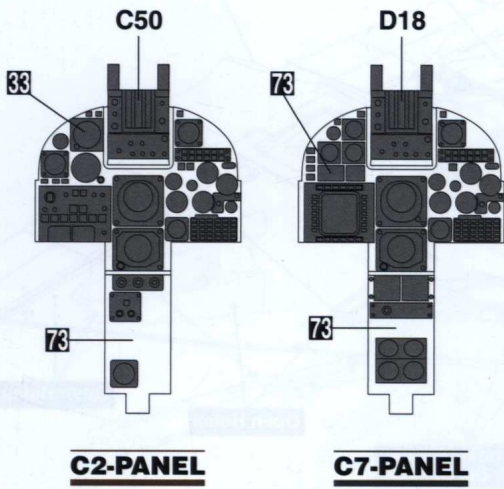

2 前起落架
Front landing gear bay

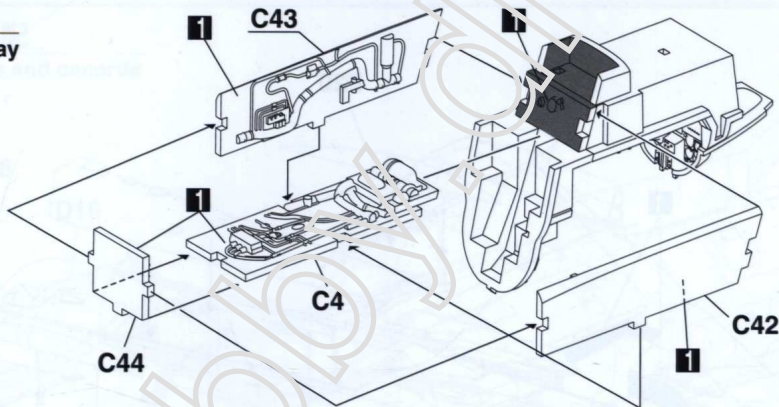

3 機身
Attaching fuselage halves

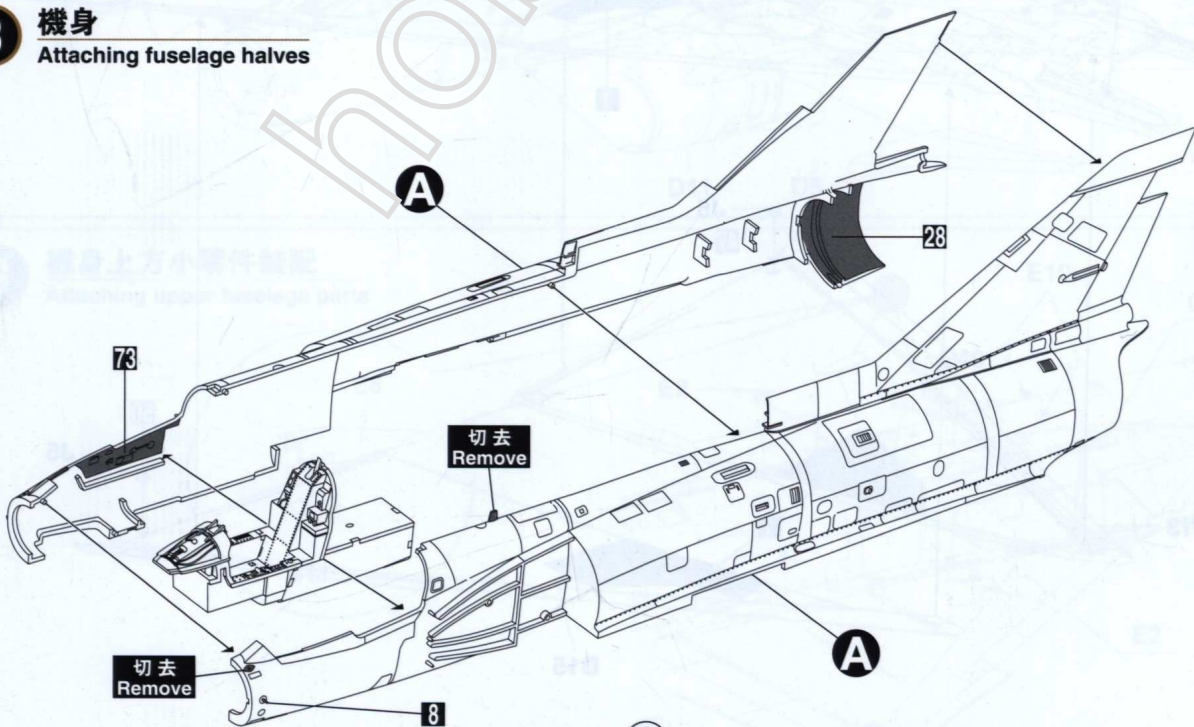

4 主起落架舱

Main landing gear wells

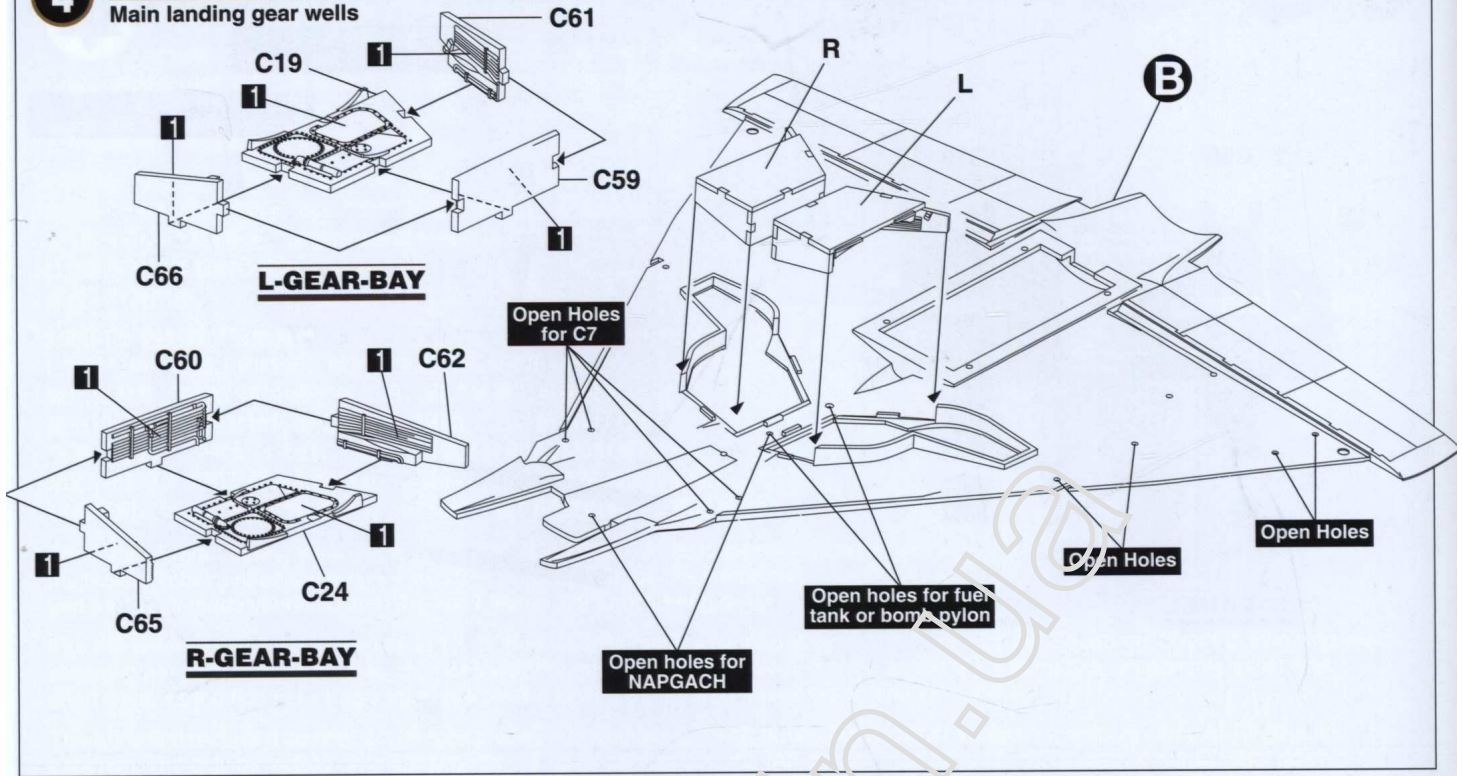

5 主机翼装配

Attaching delta wing

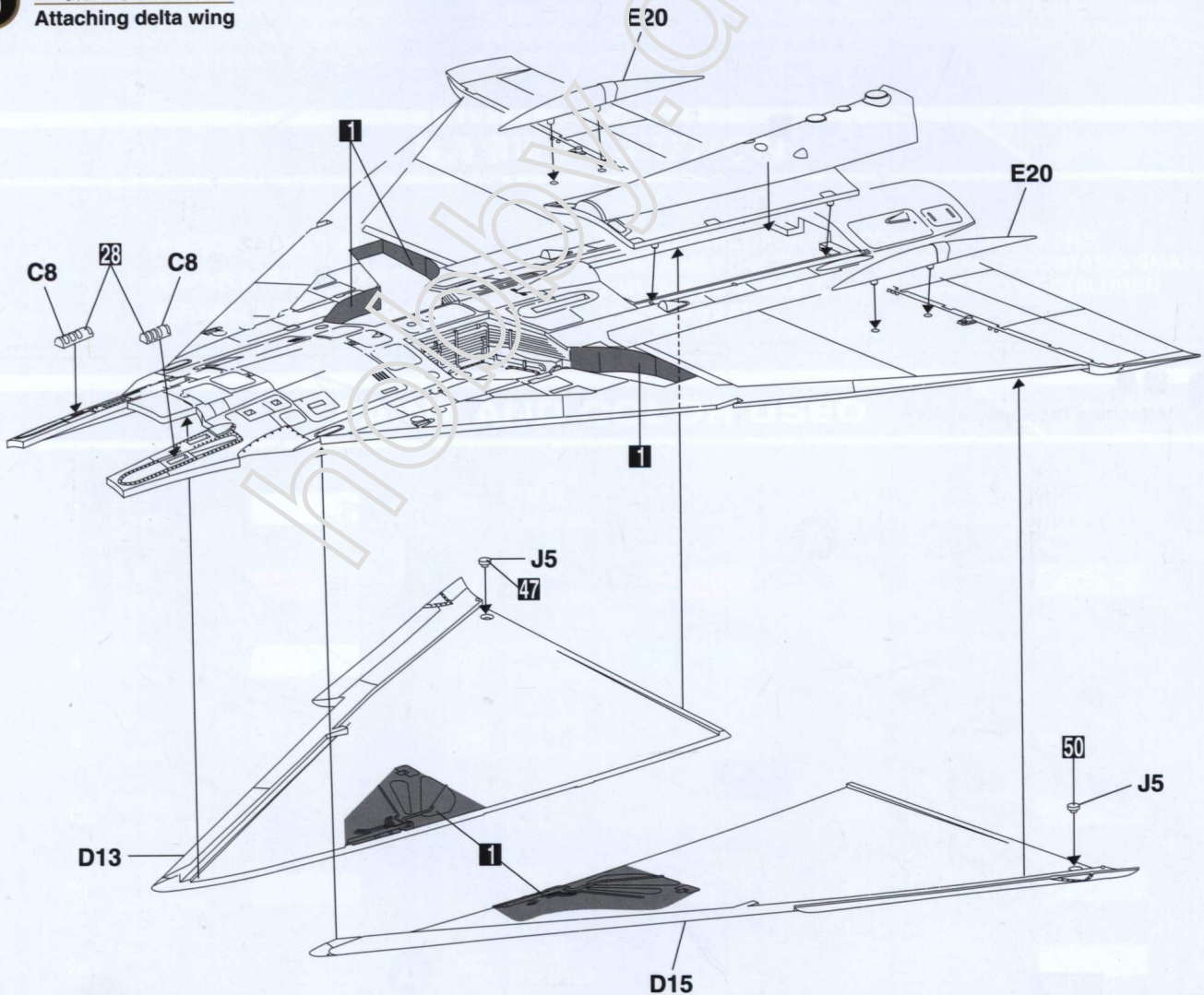

7 主翼與機身裝配
Attaching delta wing to body

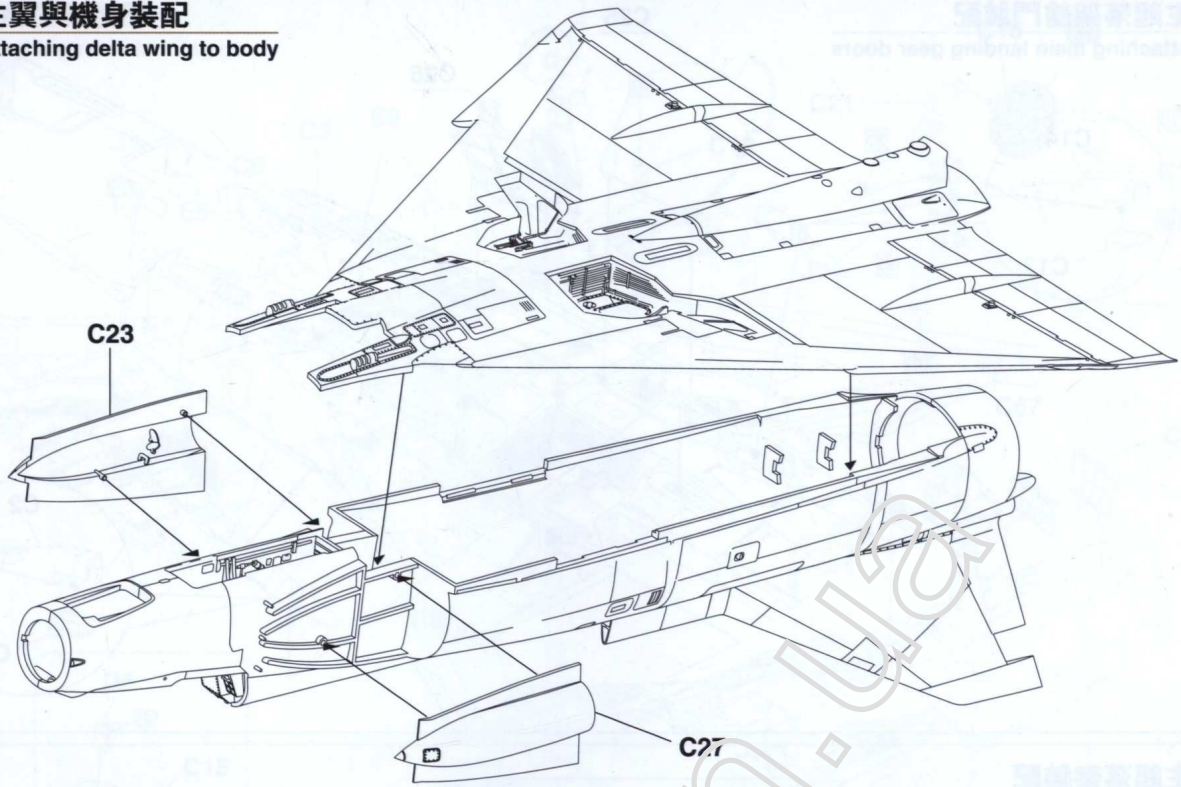

8 進氣口與前翼裝配
Attaching air intakes and canards

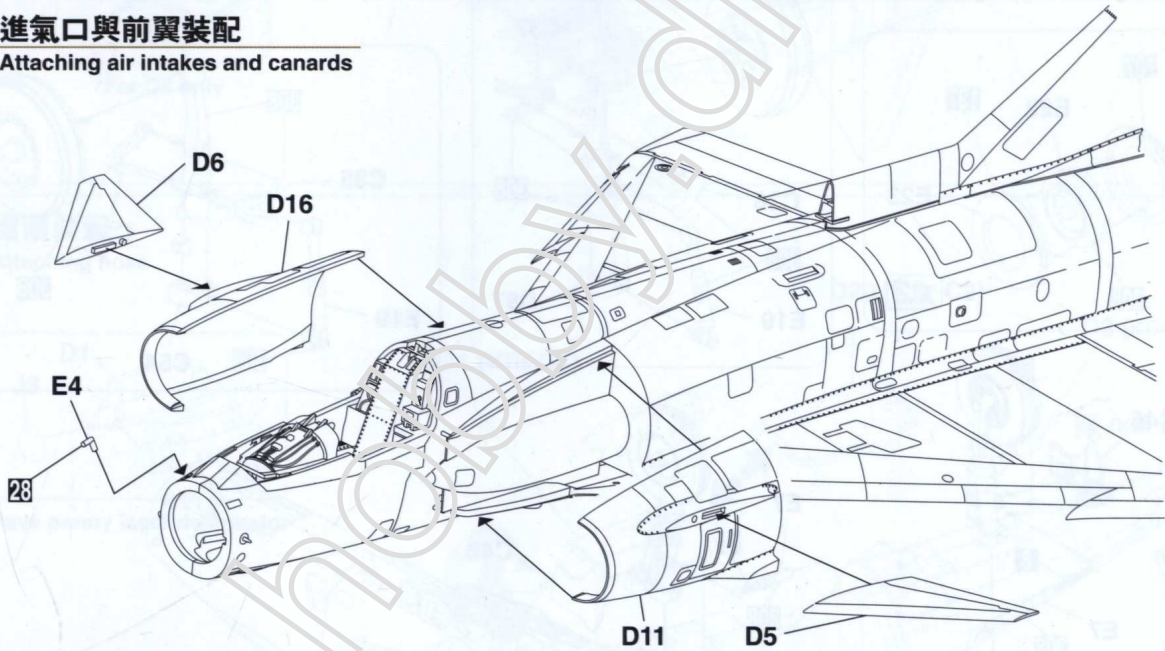

9 機身上方小零件裝配
Attaching upper fuselage parts

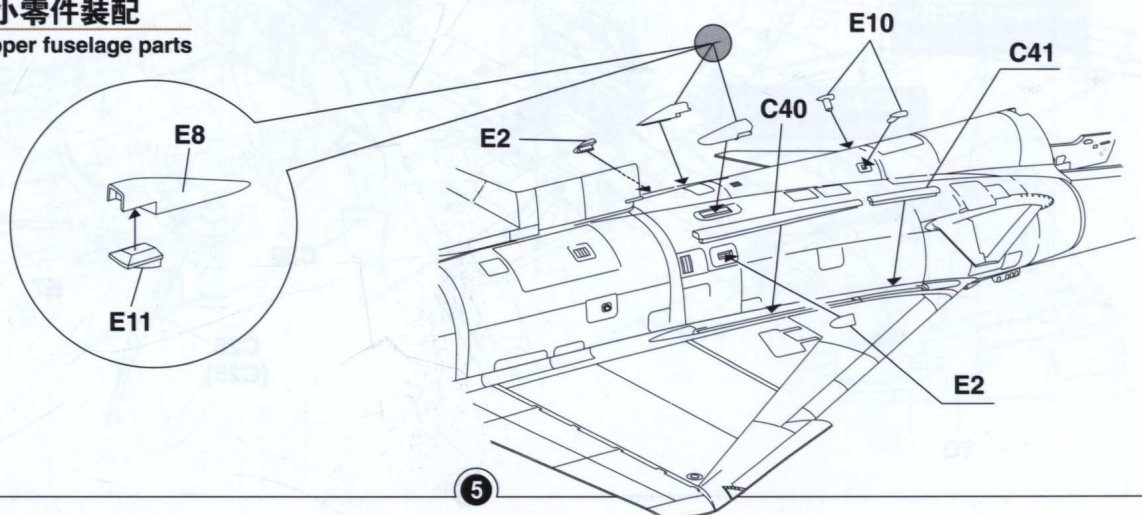

10 主起落架舱门装配
Attaching main landing gear doors

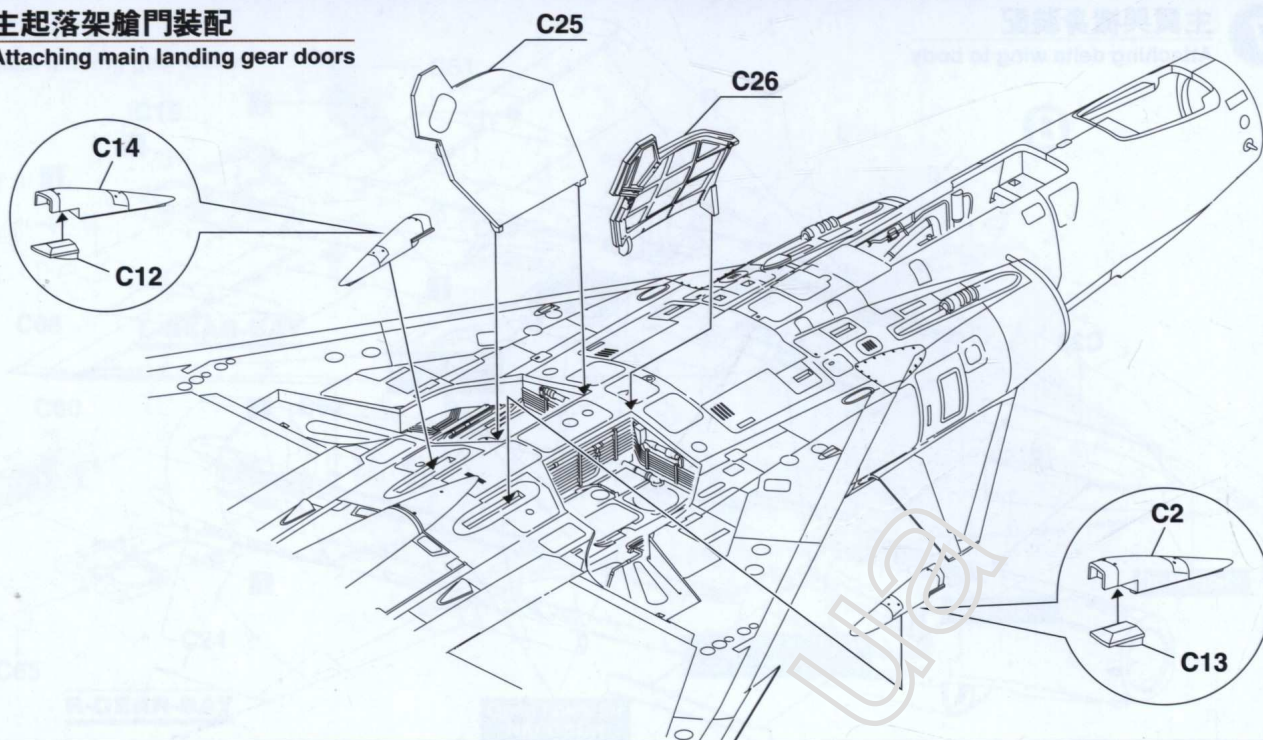

11 主起落架装配
Attaching main landing gears

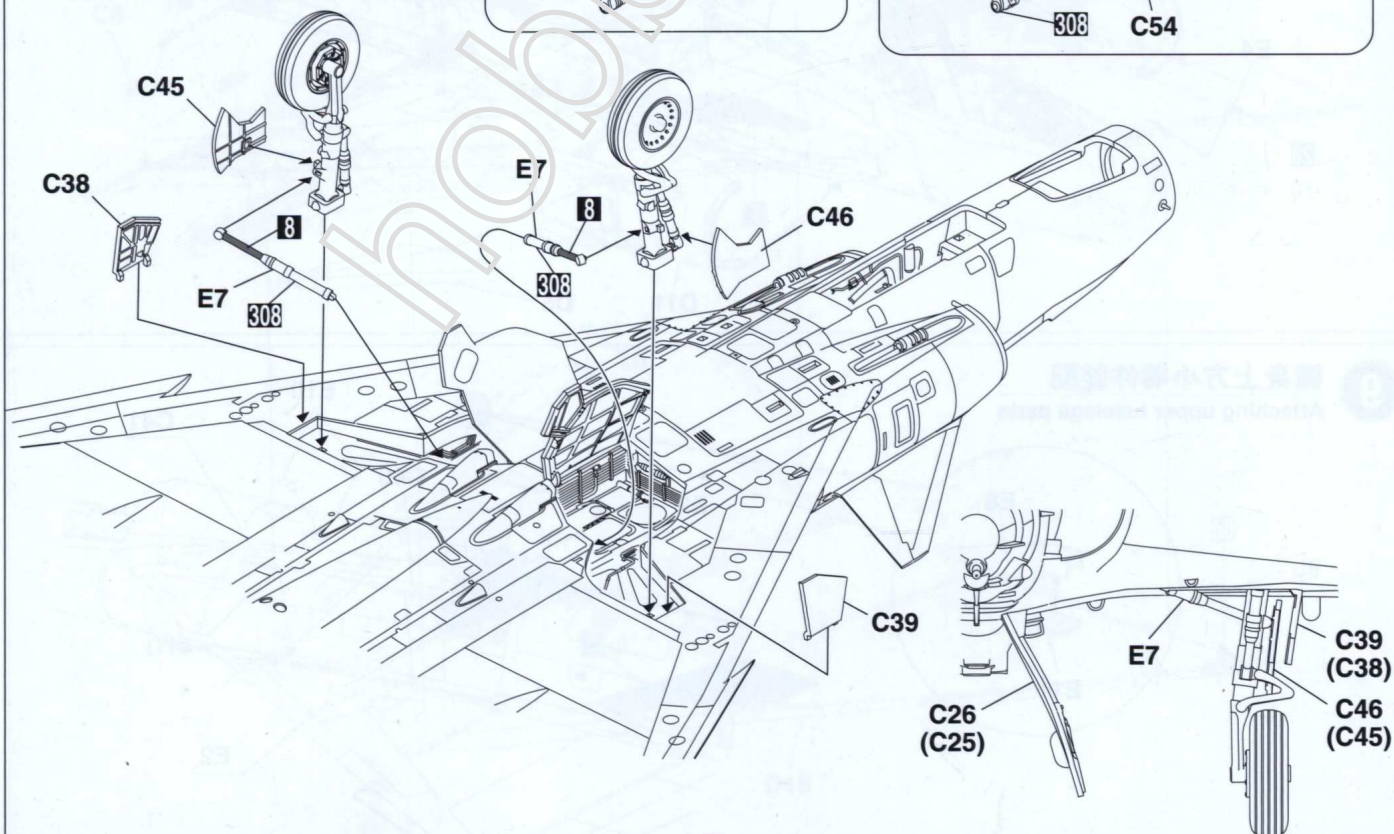
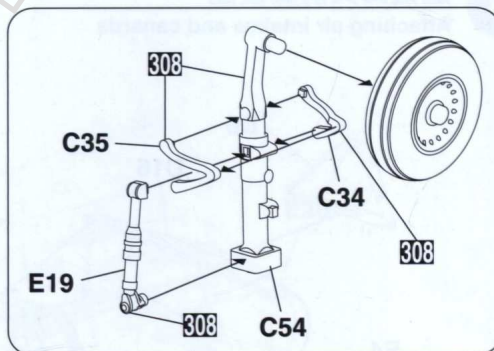
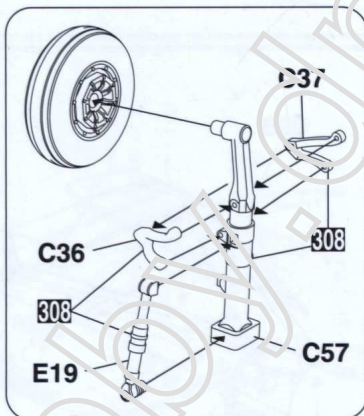
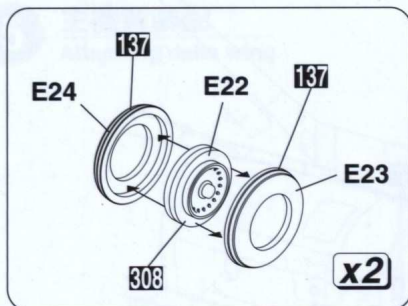

12 前起落架装配
Attaching nose landing gear

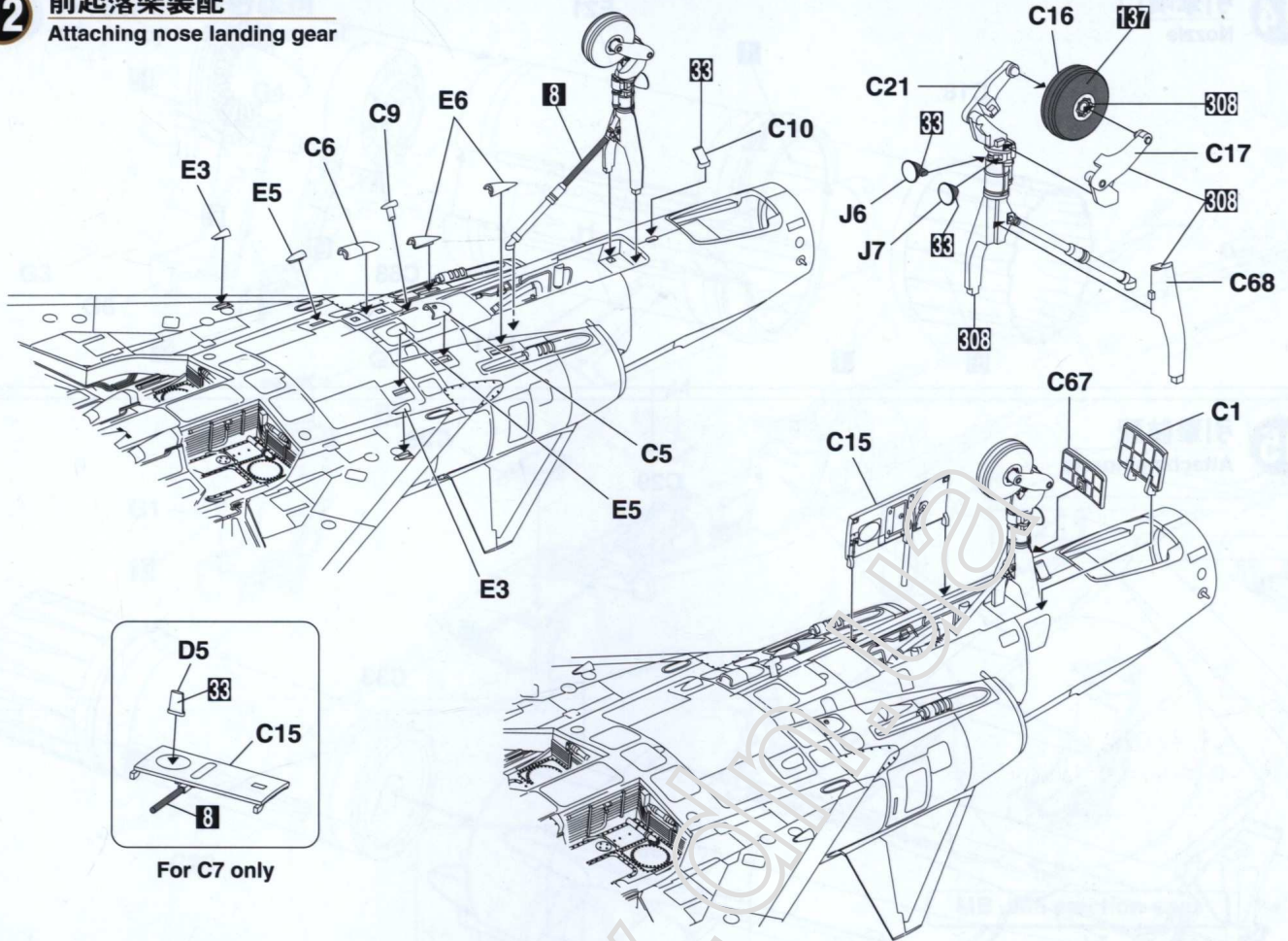

13 機頭装配
Attaching nose

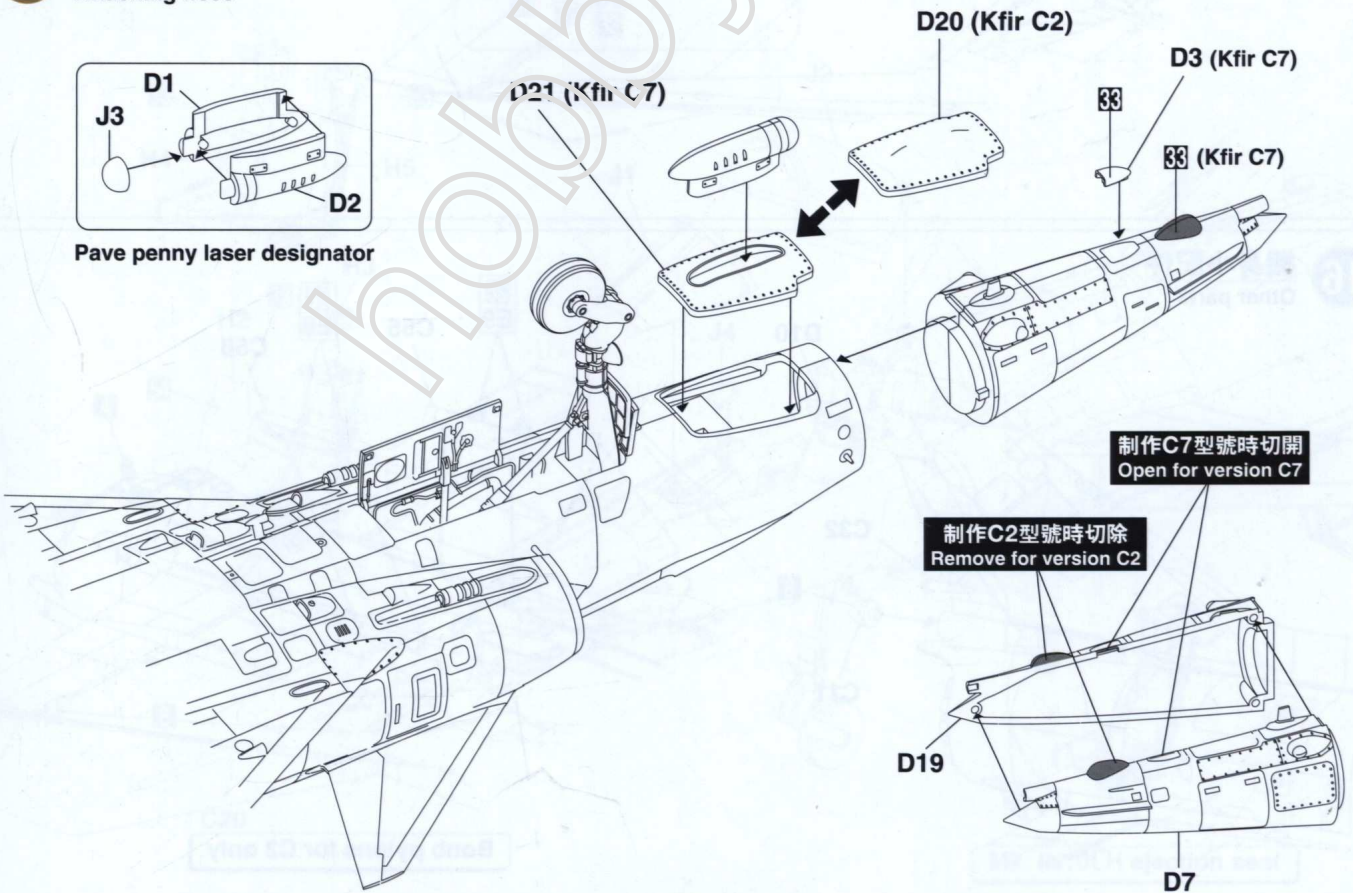

14 引擎噴口
Nozzle

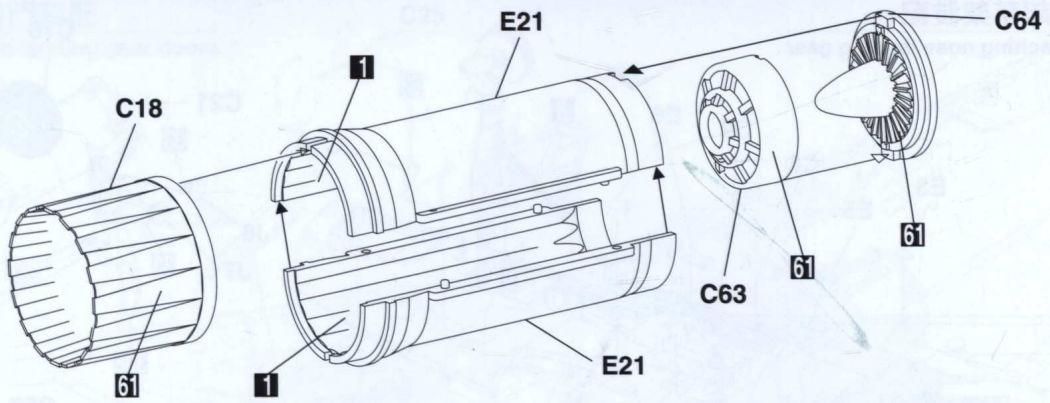

15 引擎裝配
Attaching nozzle

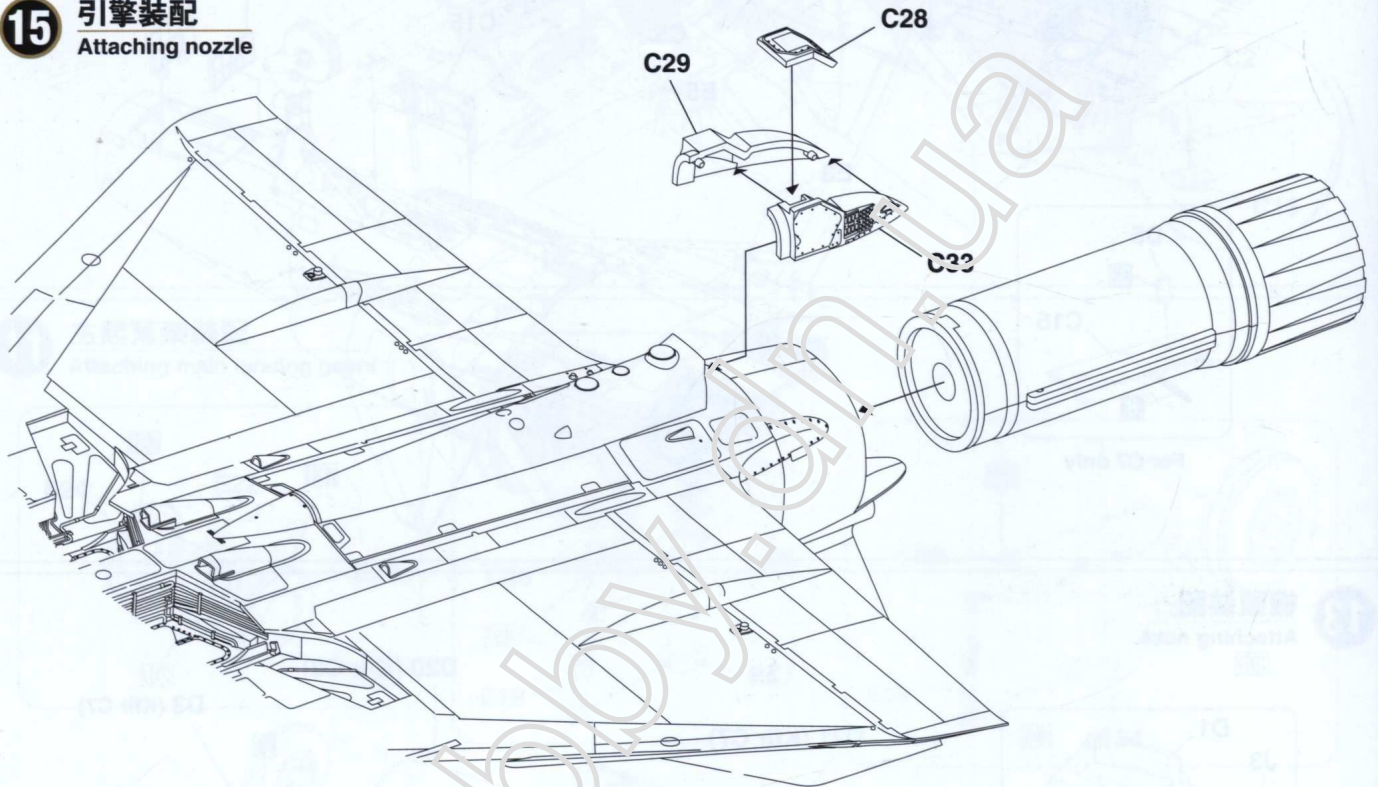

16 機身小配件
Other parts

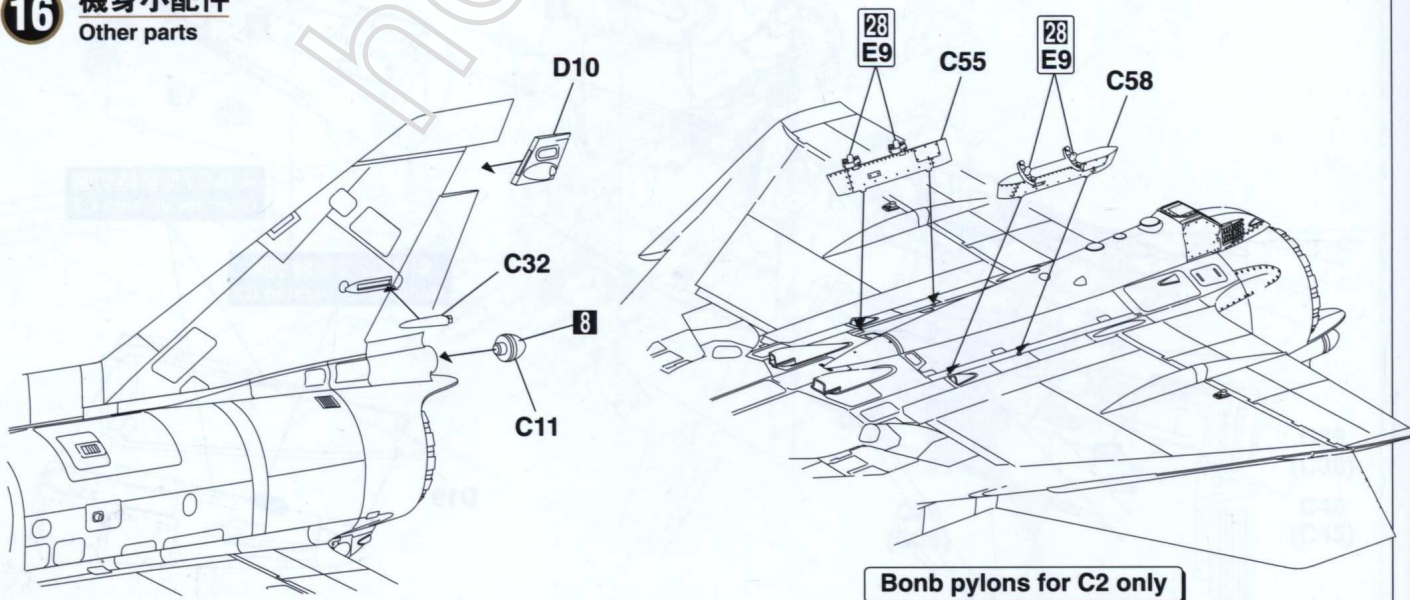

17 C2 坐艙與彈射座椅
C2 canopy and ejection seat

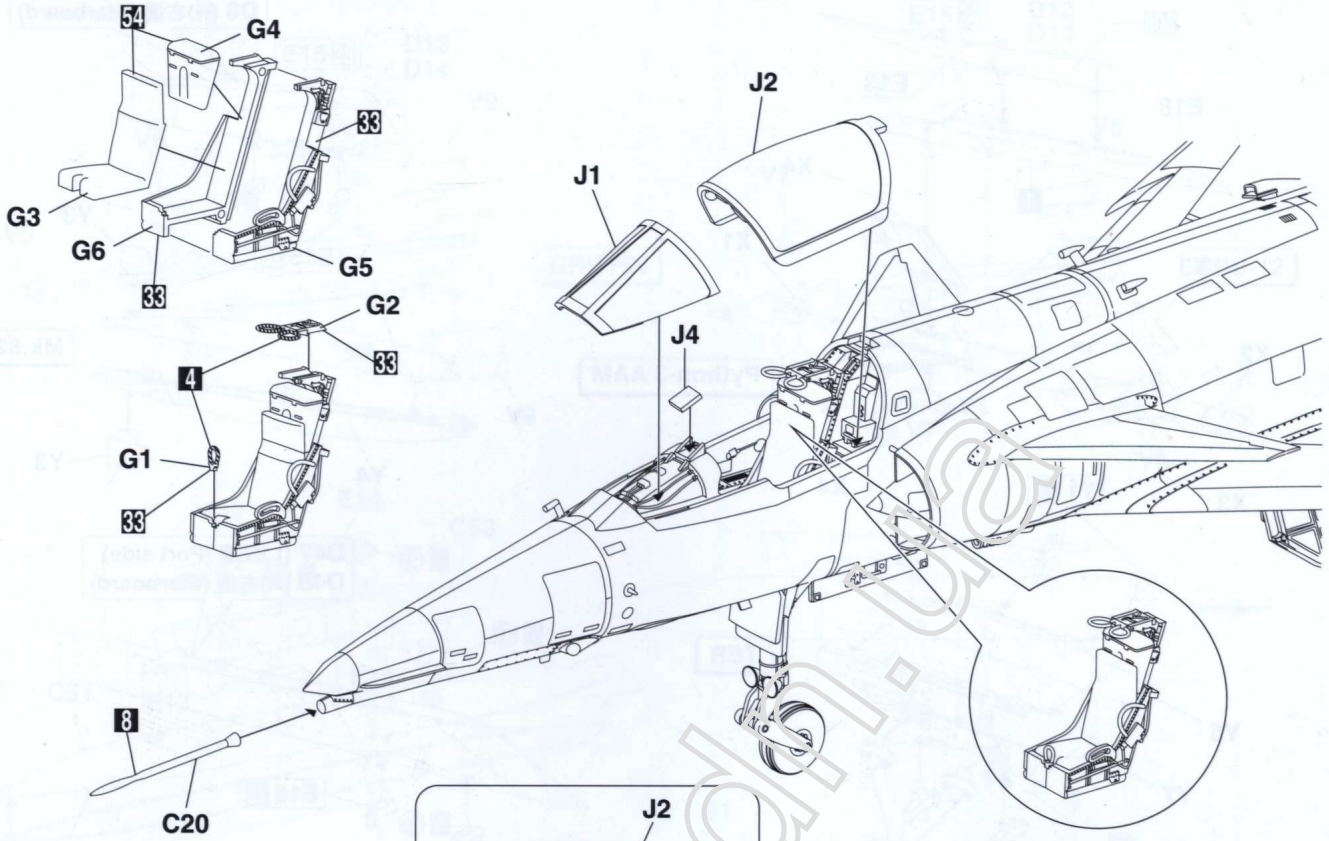

MB JM6 ejection seat

18 C7 坐艙與彈射座椅
C7 canopy and ejection seat

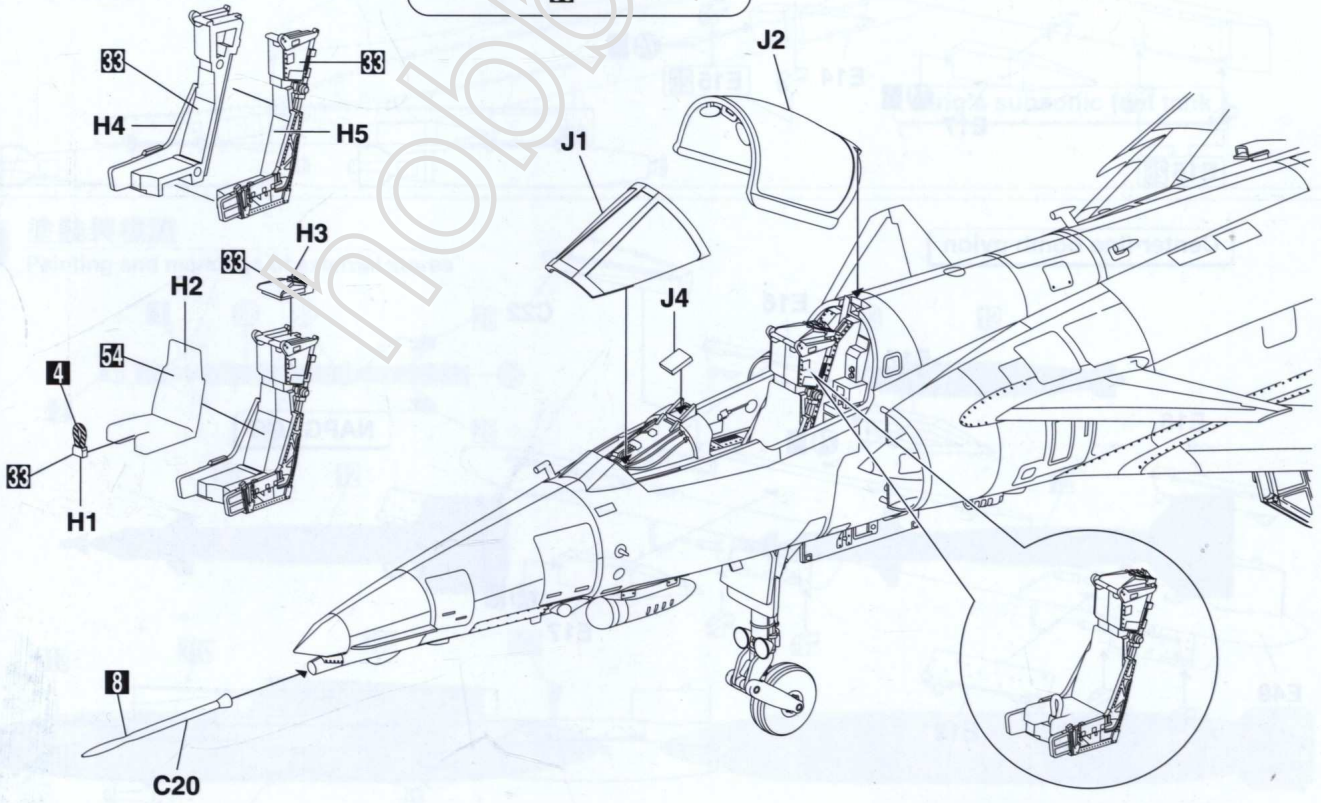

Mk. IN10LH ejection seat

19 飛彈炸彈與武器掛架
Pylons, missile launcher and bomb racks

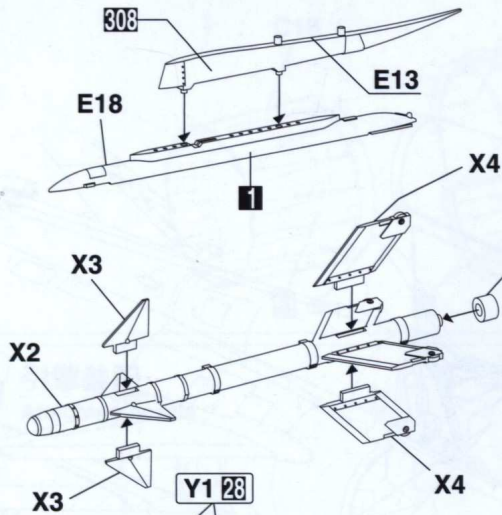

Python-3 AAM

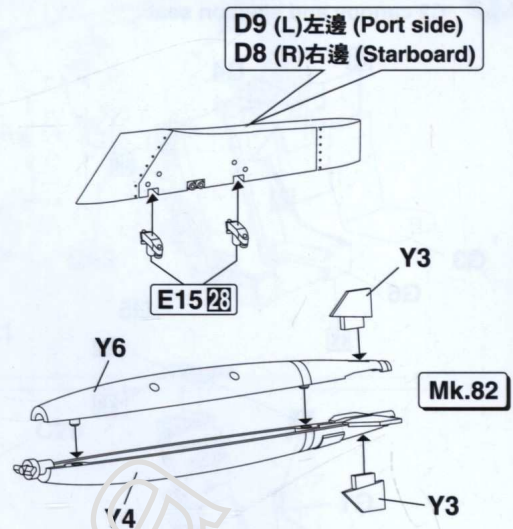

Mk.82

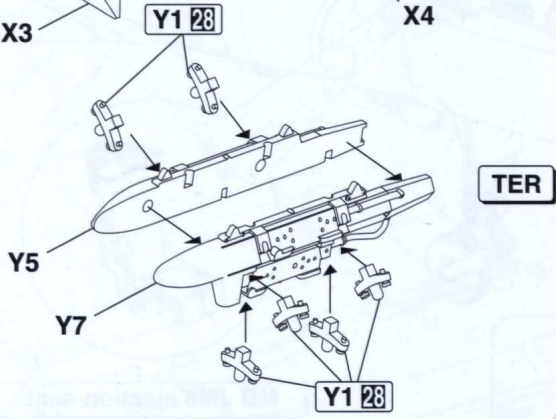

TER

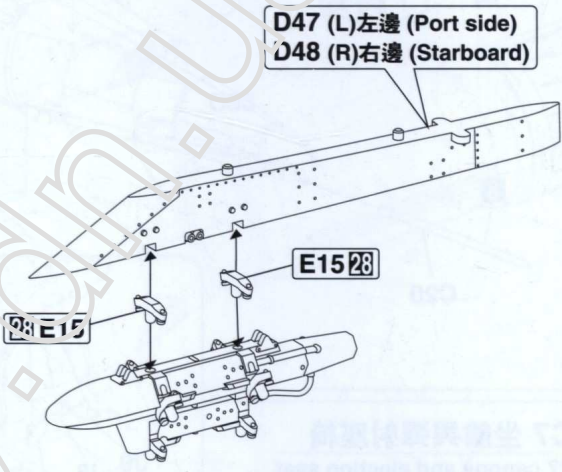

Wing pylon with TER

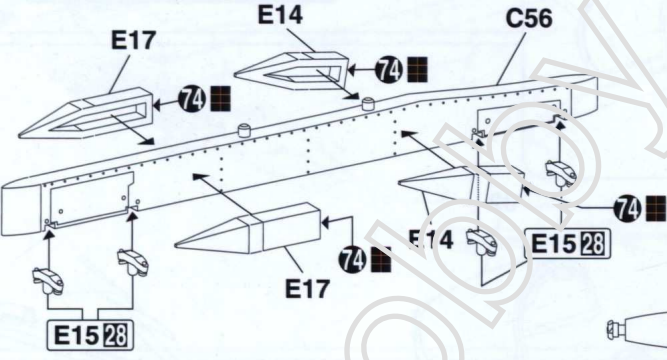

Center-line bomb pylon

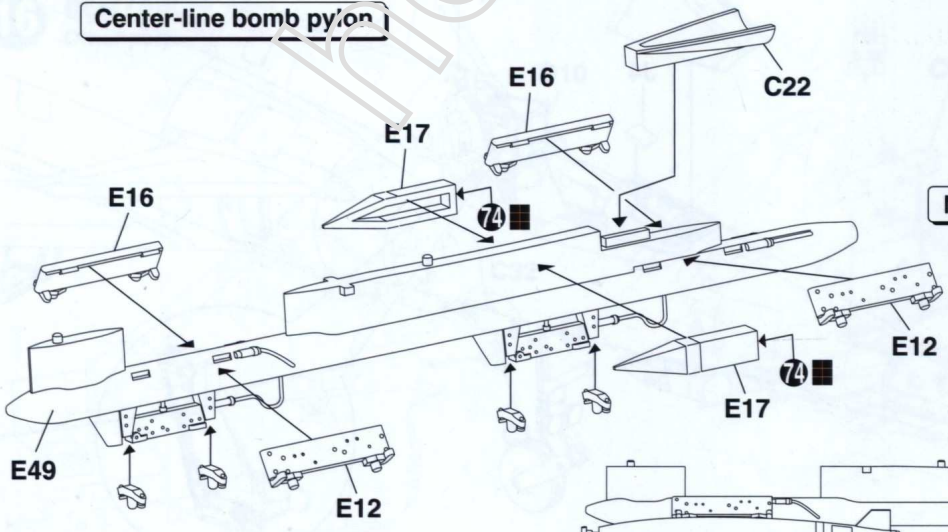
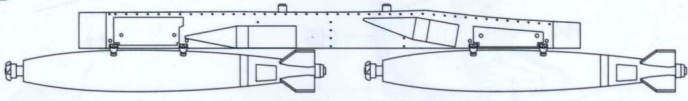

NAPGACH

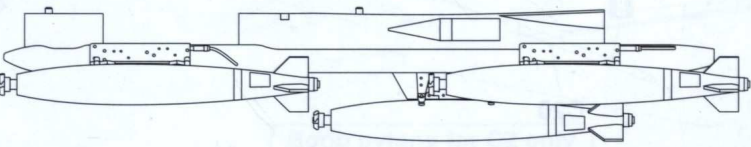

20 激光制導炸彈與外掛油箱
Laser guided bombs and external fuel tanks

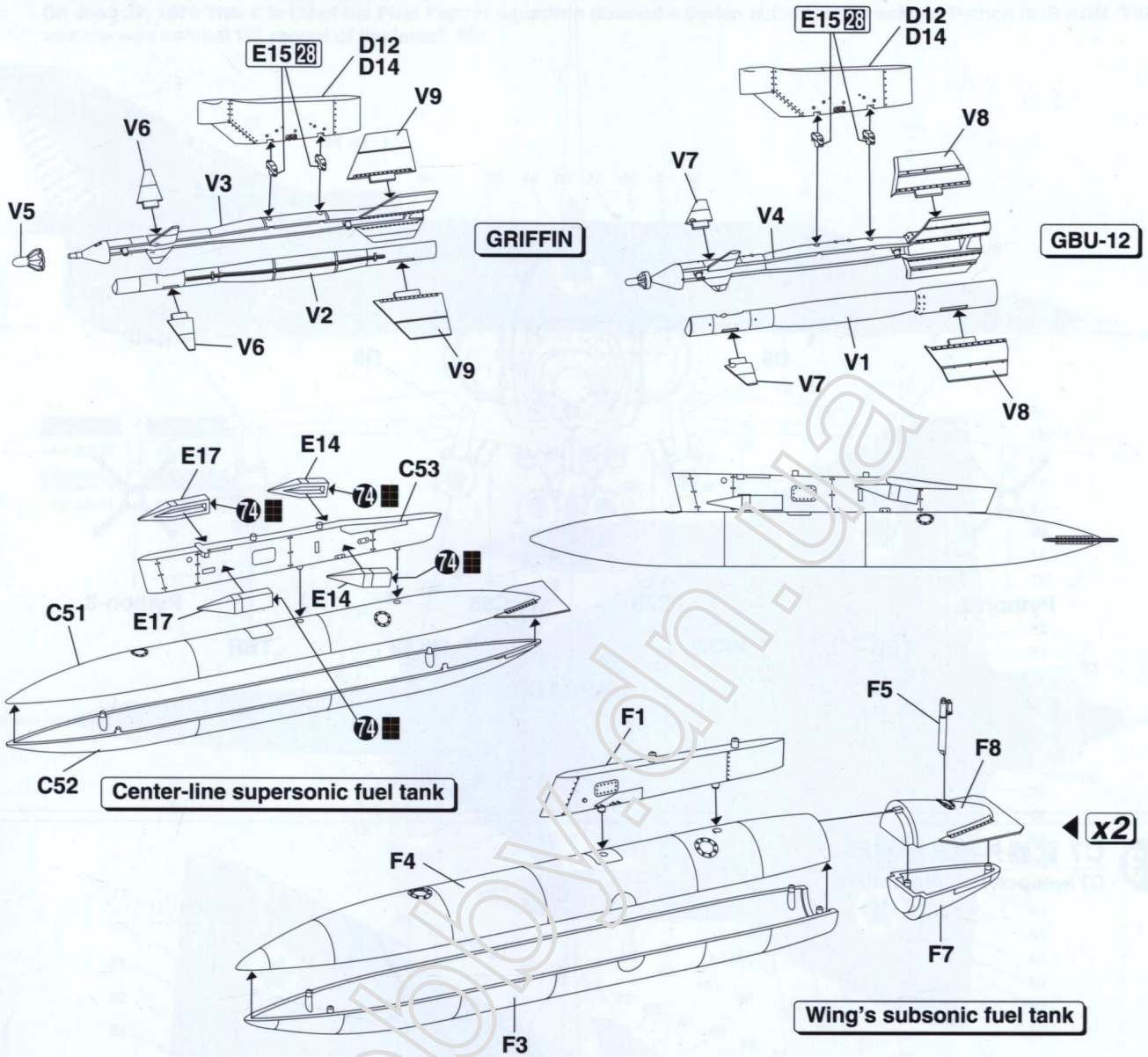

21 塗裝與標識
Painting and markings of external stores

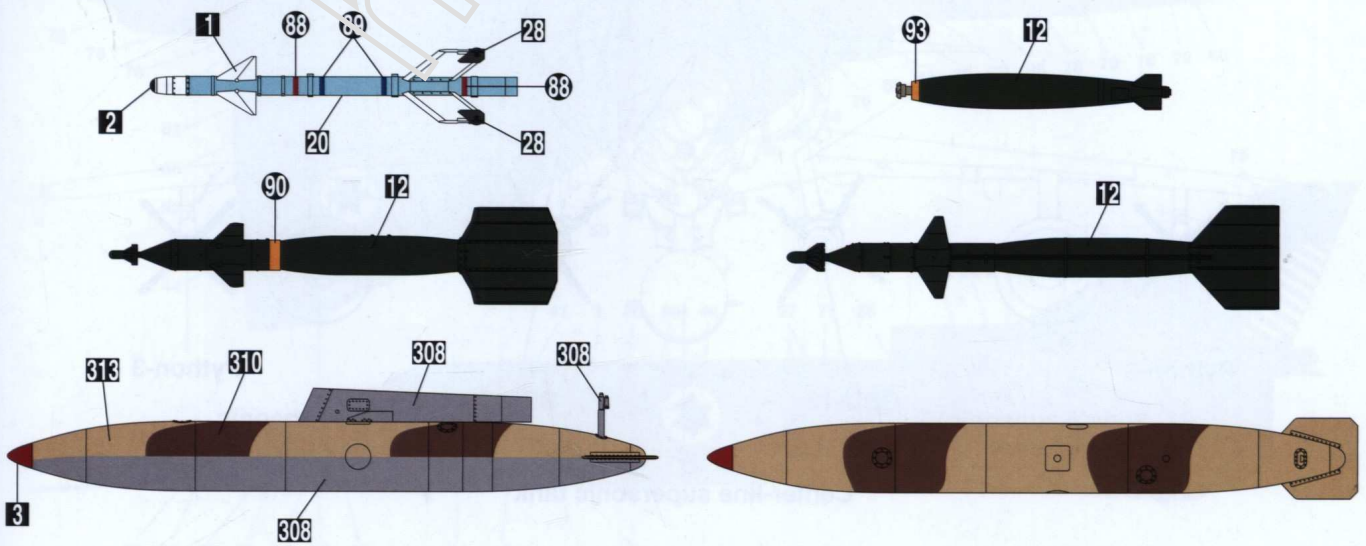

22 C2 武器外挂装配展示
C2 weapons configuration

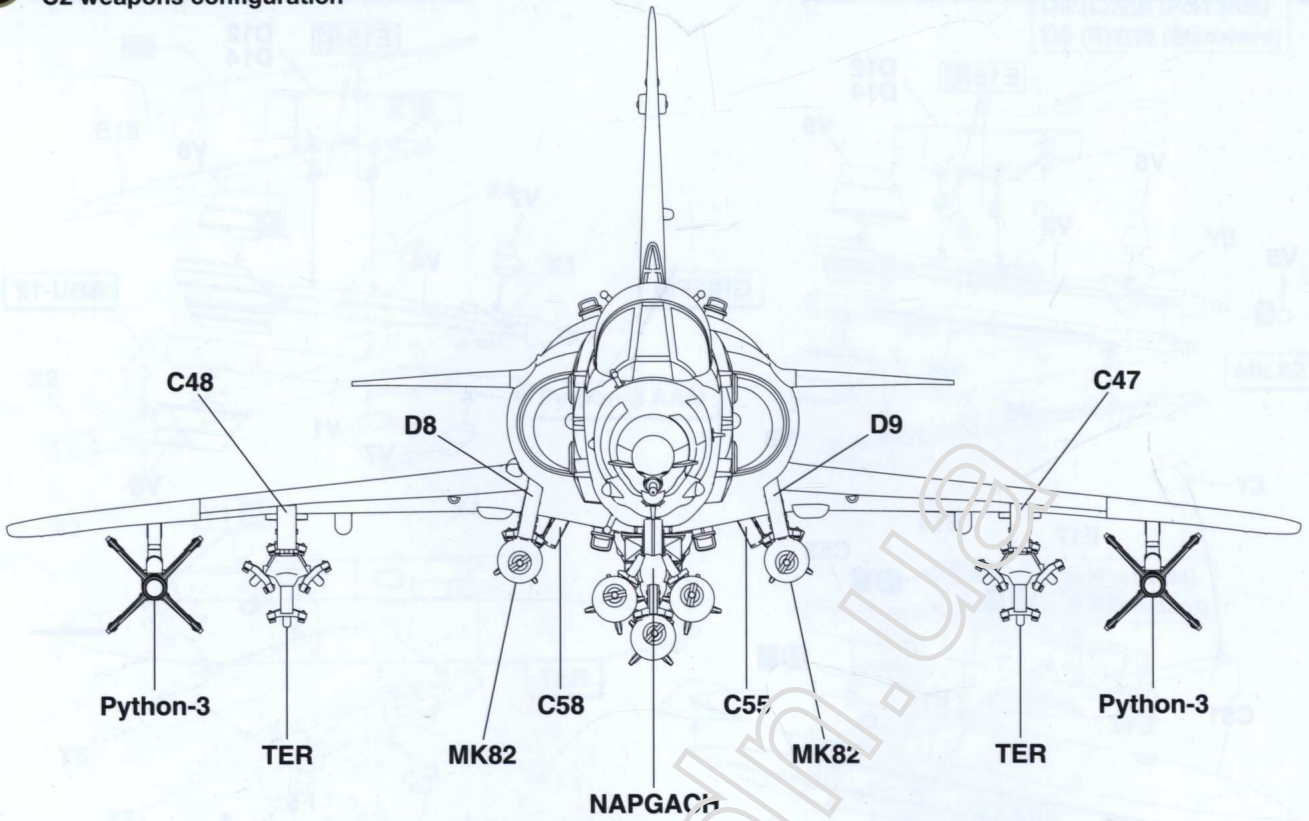

23 C7 武器外挂装配展示
C7 weapons configuration

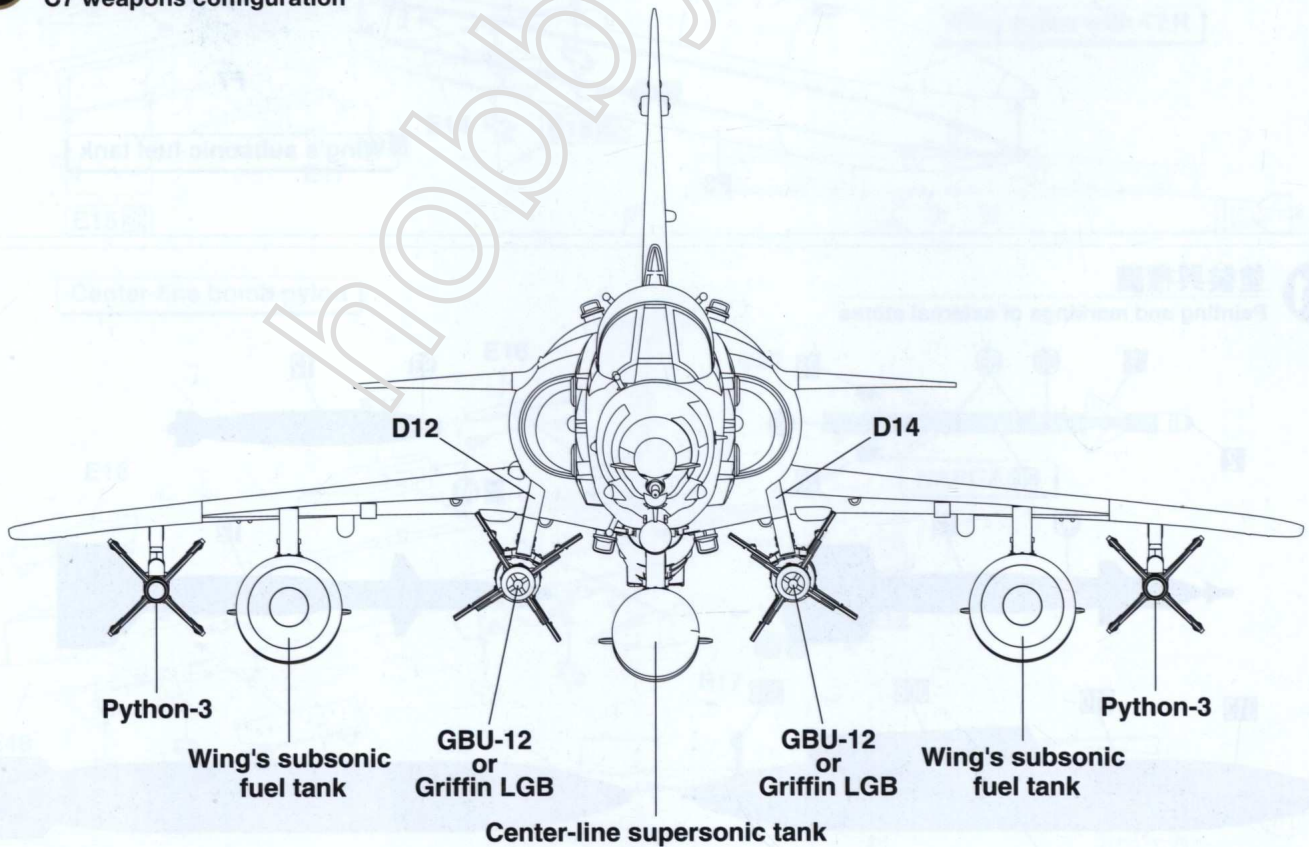

C2 Kfir C2 #874, The First Fighters Squadron 1979

2nd Color scheme

On June 27, 1979 This Kfir C2 of the First Fighter squadron downed a Syrian MIG-21MF by using a Python III IR AAM. This was the sole combat kill record of the Israeli Kfir.

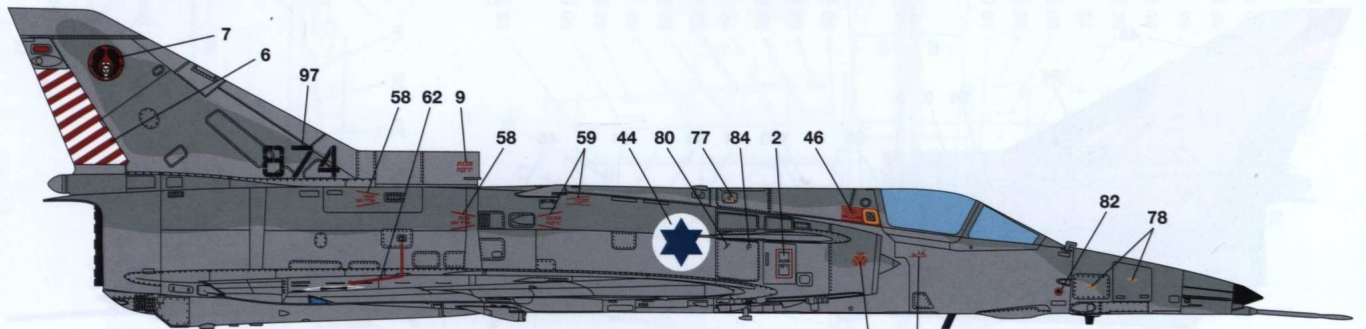

FS 30219	FS 36320
FS 33531	FS 36375

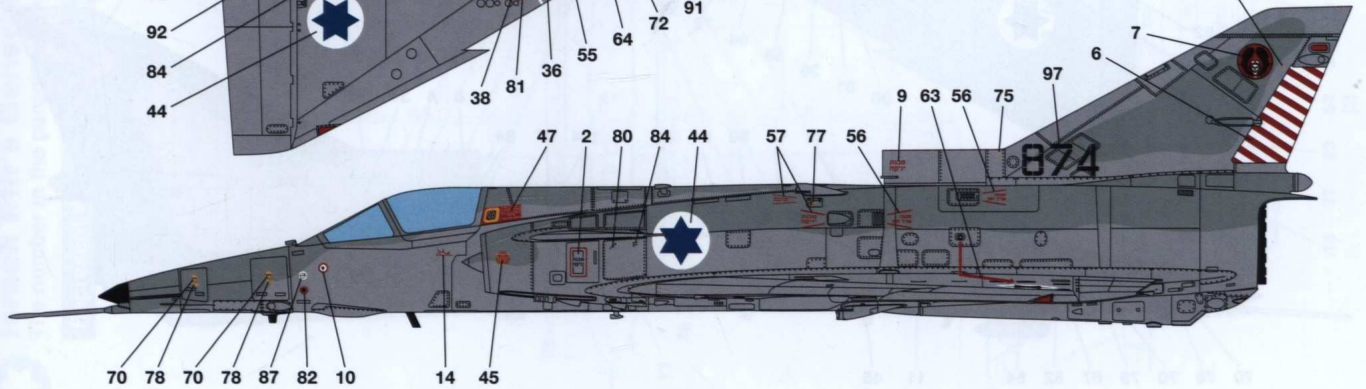
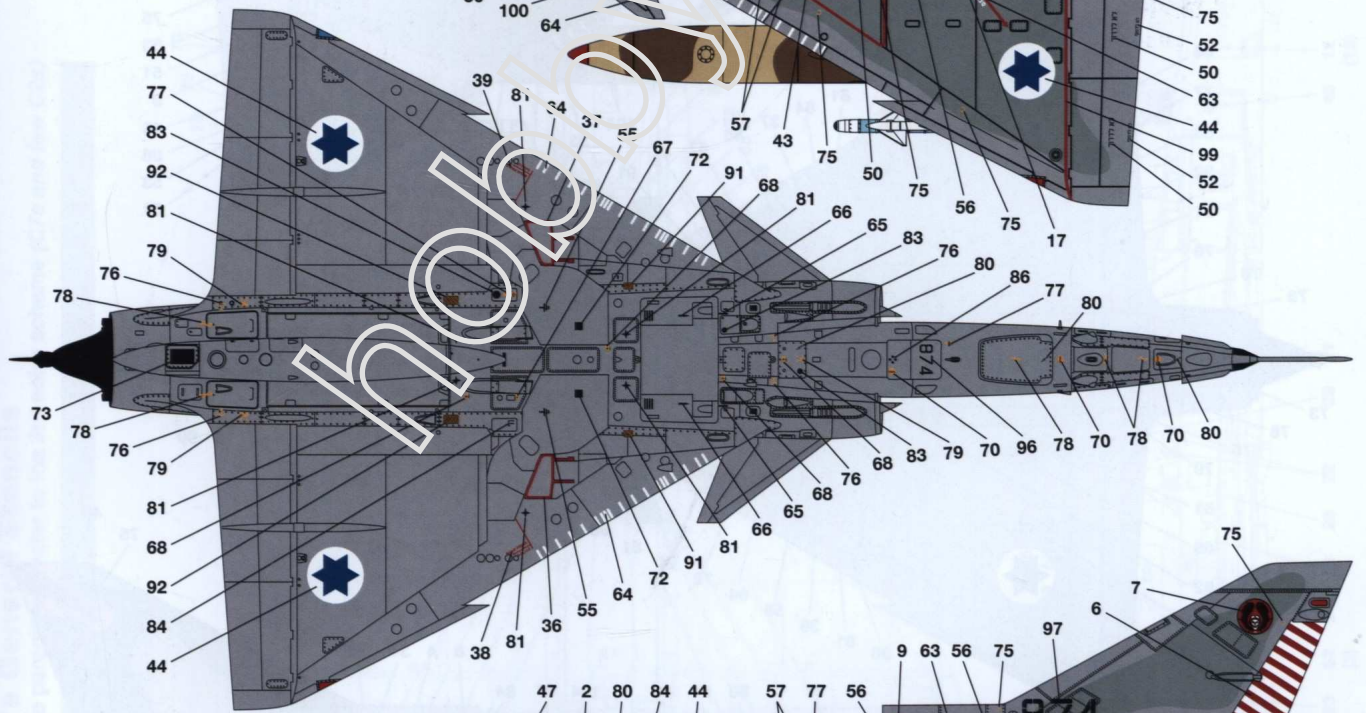
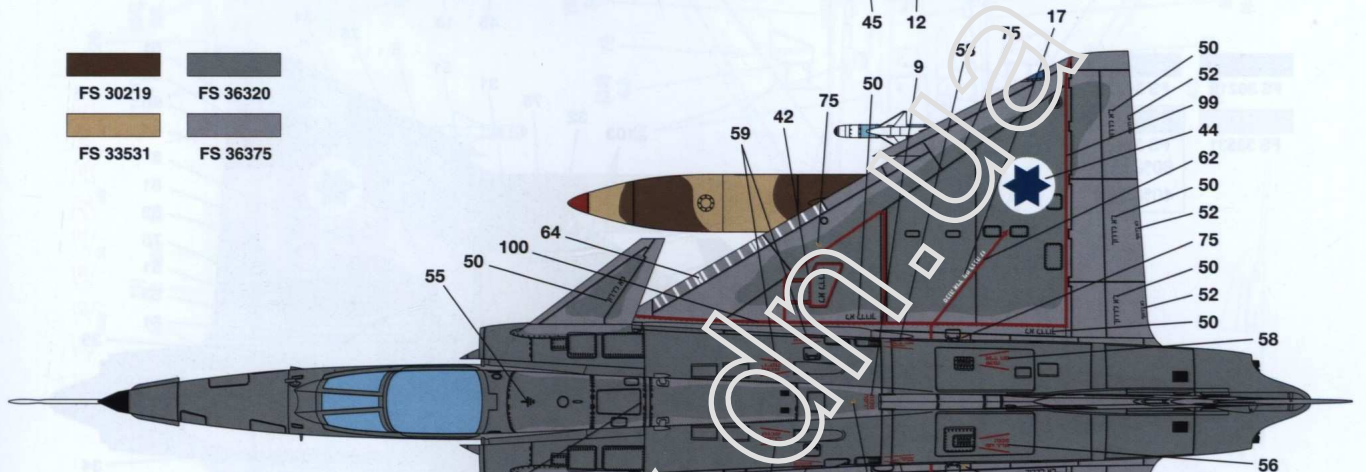

C7 Kfir C7 #555, The Arava Guardians Squadron 1990

3rd Color scheme

The Kfir C7 is the improved ground attack version of the Kfir series. This version entered service with the Arava Guardians squadron in 1983.

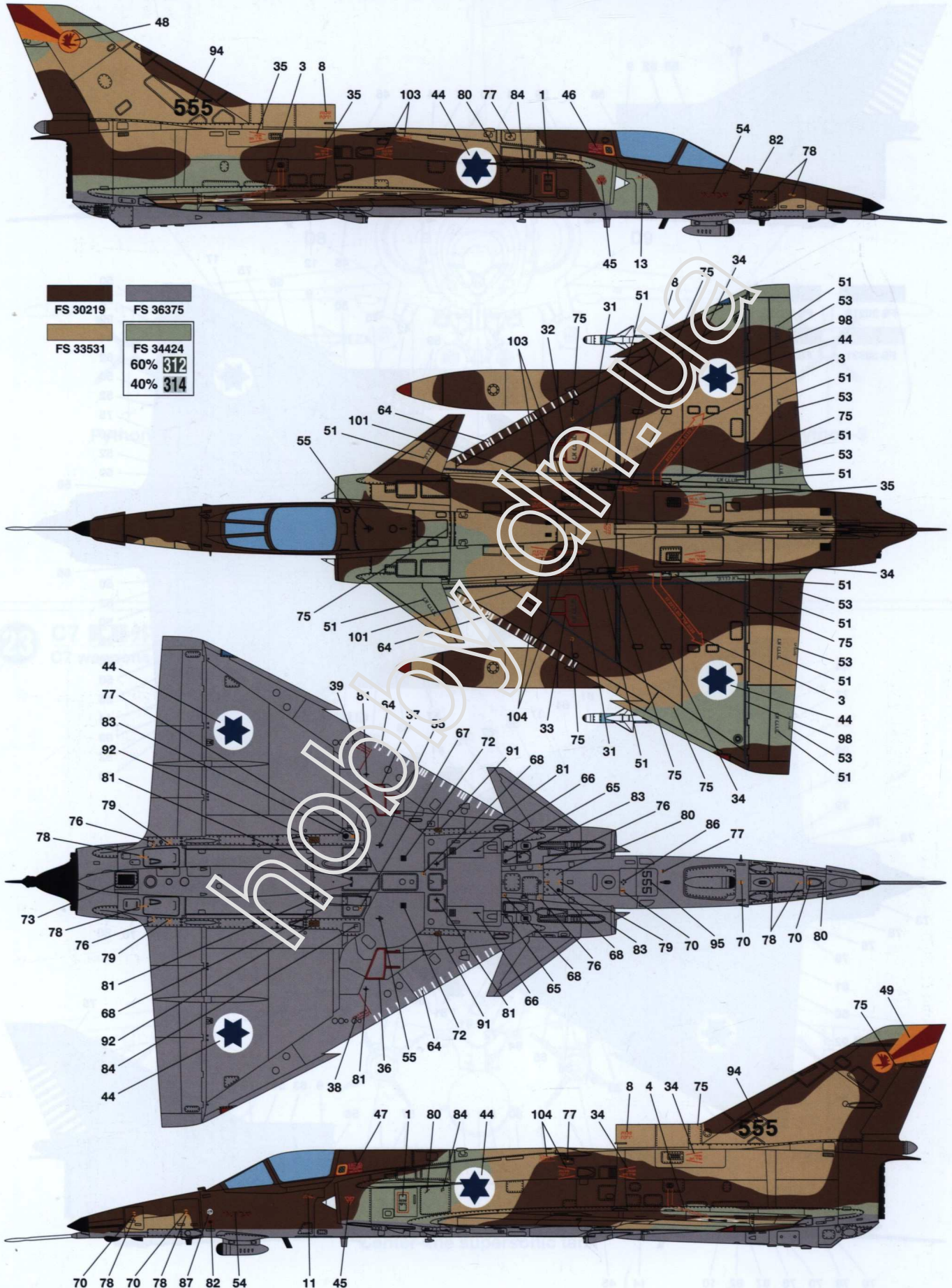

FS 30219	FS 36375
FS 33531	FS 34424
	60% 312
	40% 314



Israeli Kfir's General Stencils

The number in the parenthesis refer to the 3rd color scheme (C7s and few C2s)

Represent White

