

# Gee Bee Super Sportster R-1 & R-2

1/144 SCALE MODEL CONSTRUCTION KIT

Ready to assemble scale models kit.

Contains part for one model.

Model length: 35 mm

Wingspan: 54 mm

Plastic parts: 25

The R-1 rapidly earned a reputation as a potentially very dangerous machine. The small wings, very low polar moment of inertia, and tiny control surfaces made for an aircraft that could rapidly get away from all but the most skilled pilots. This shortcoming was common to most air racers of the day.

During the 1933 Bendix Trophy race, racing pilot Russell Boardman was killed, flying Number 11. After taking off from a refueling stop in Indianapolis, Indiana, the R-1 stalled, and crashed.

Note that the R-2 originally used a 550 hp Pratt & Whitney R-985 Wasp Junior nine cylinder radial powerplant, as the aircraft was designed primarily as a cross-country racer with increased tankage that did not require the larger 800 hp Wasp. In 1933, the R-2 was modified for closed-circuit racing and was fitted with the more powerful engine and cowling of the R-1 version. Other modifications included a larger wing, equipped with flaps.

## PARTS OF THE MODEL

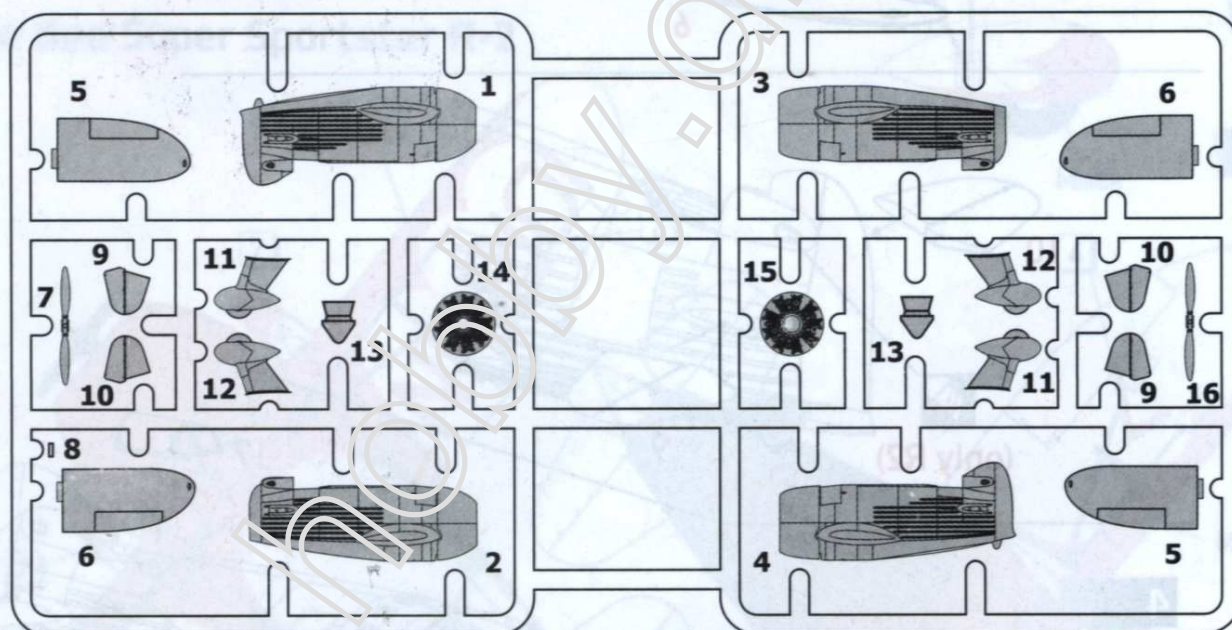

### Mask

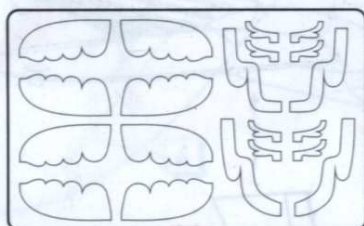

### Decal



### 17



### USED SYMBOLS



CEMENT



DON'T CEMENT



REMOVE



SYMMETRICAL



MULTIPLE



BEND



OPEN WHOLE



VARIANTS



TO PAINT

# ASSEMBLY INSTRUCTION

DW 144-03

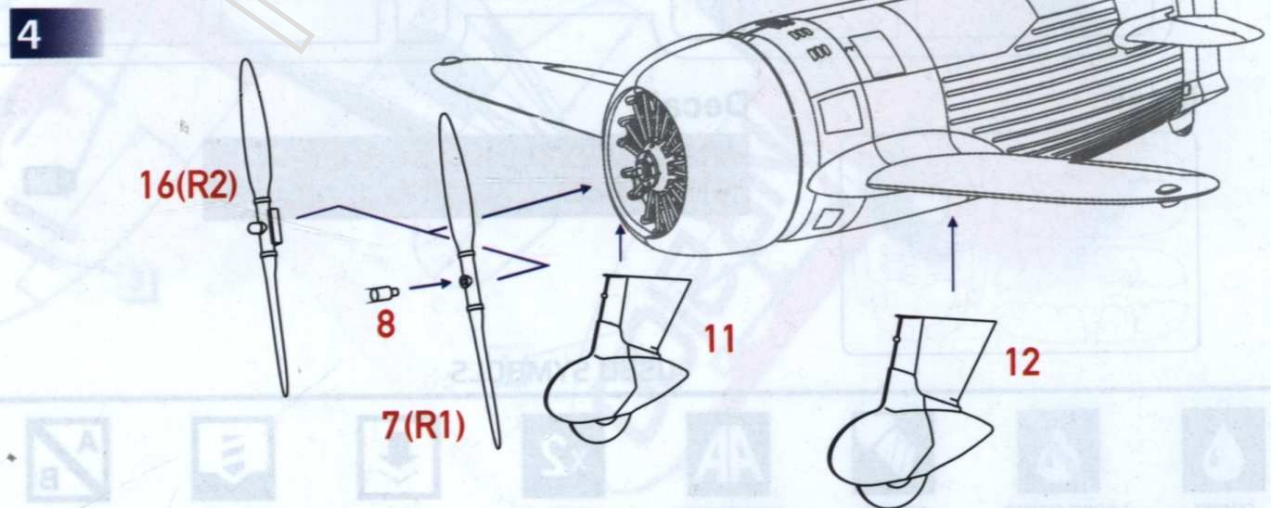
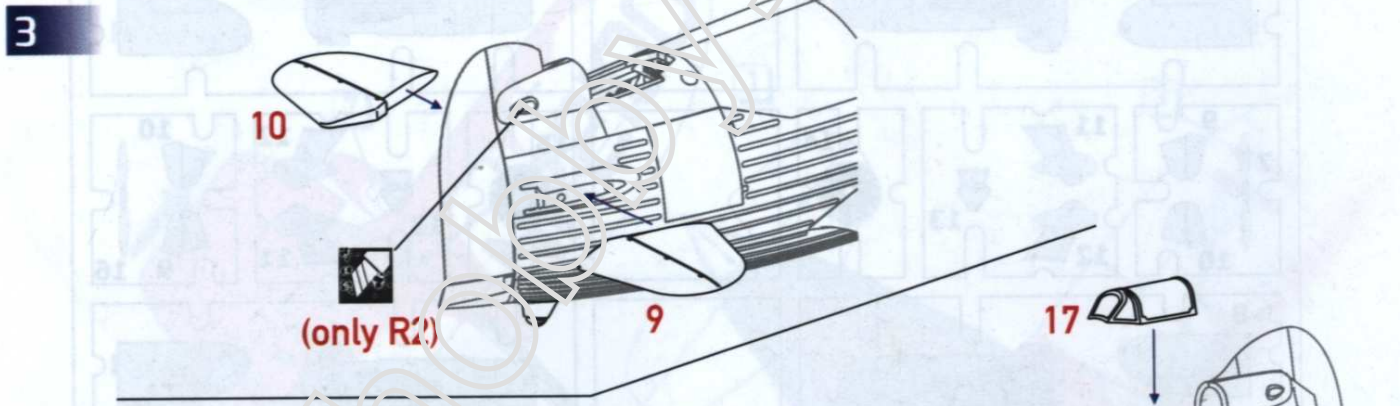
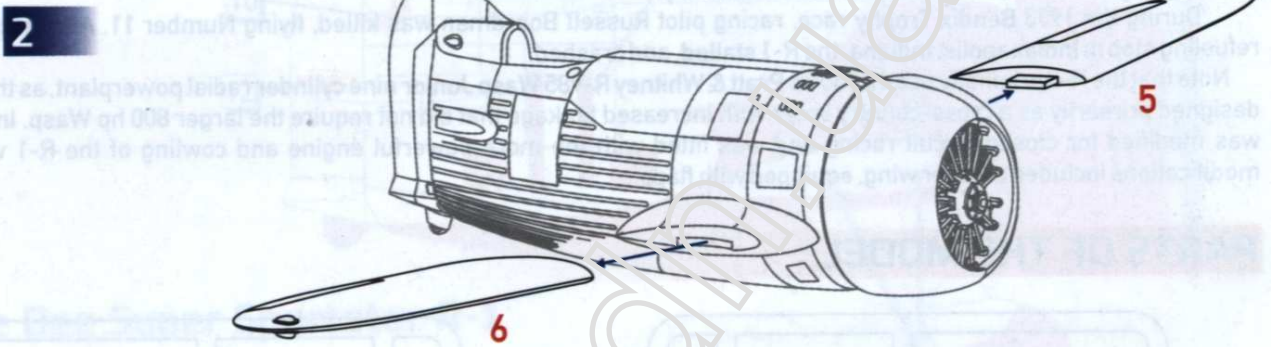
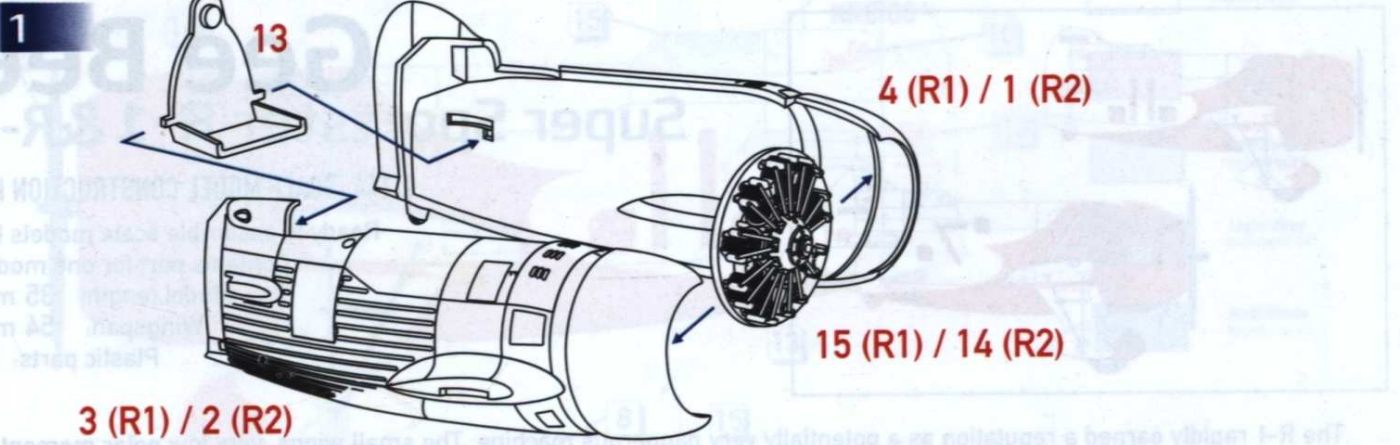

# COLOR SCHEME

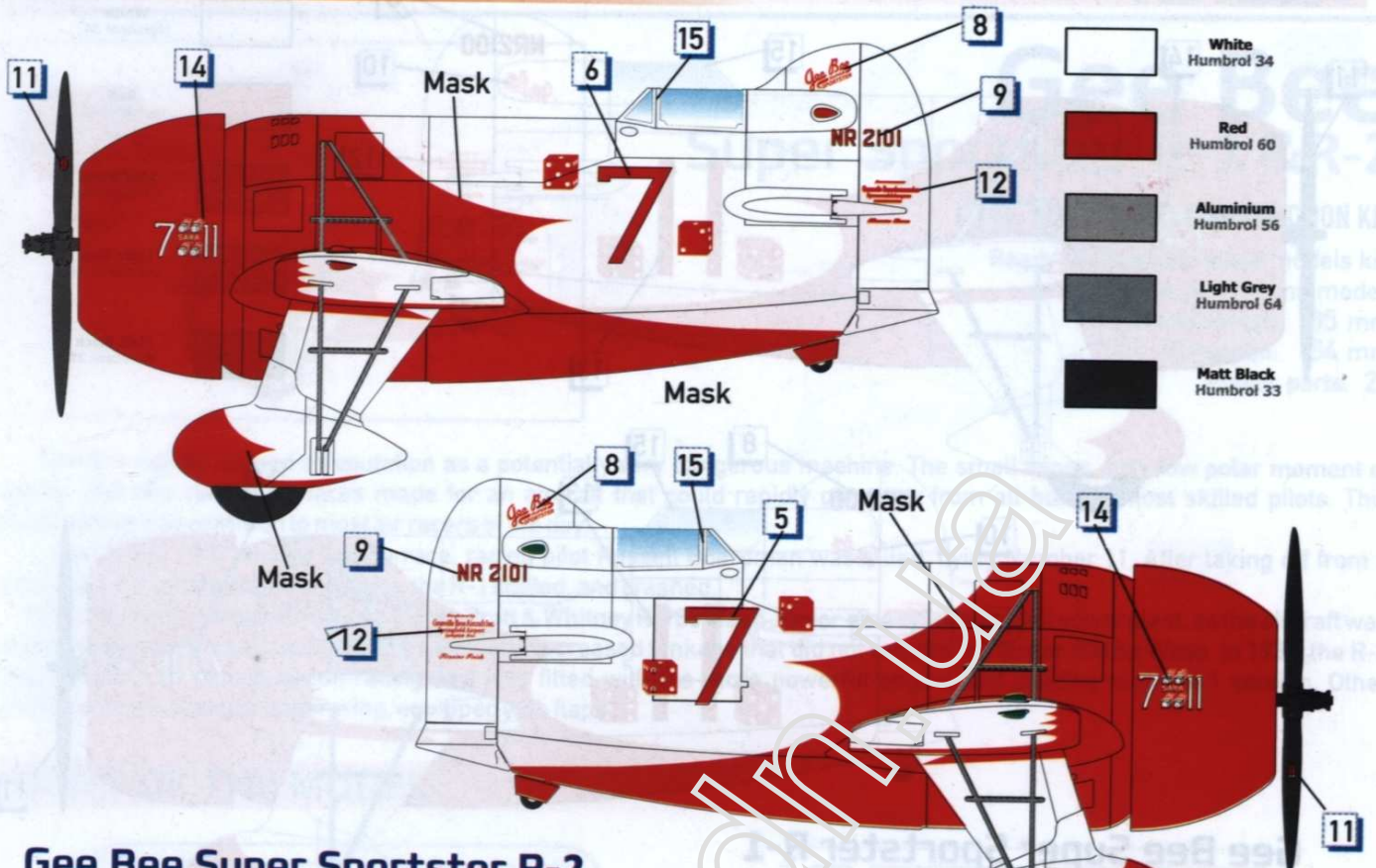

Gee Bee Super Sportster R-2

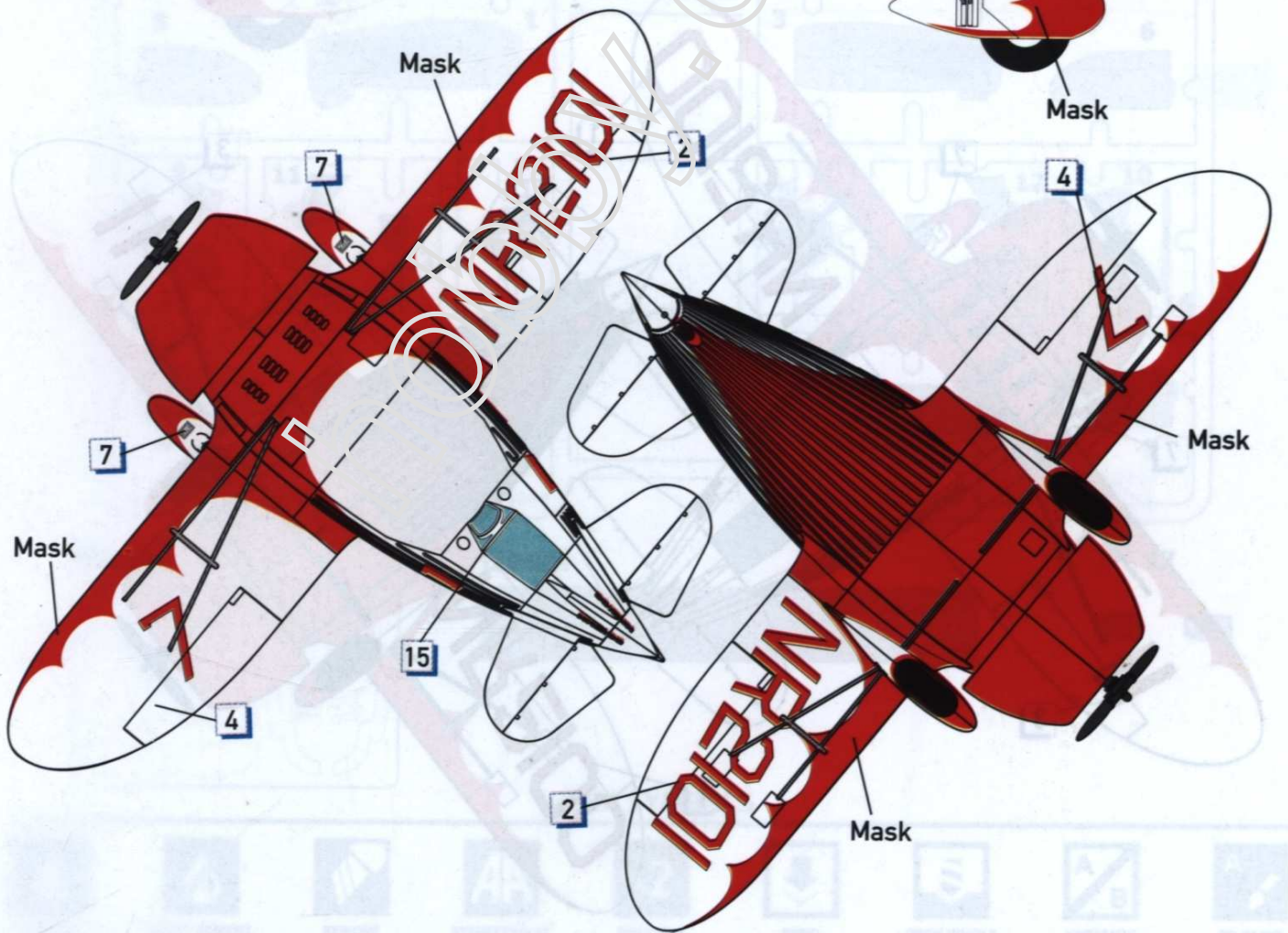

Gee Bee Super Sportster R-1 & R-2

# COLOR SCHEME

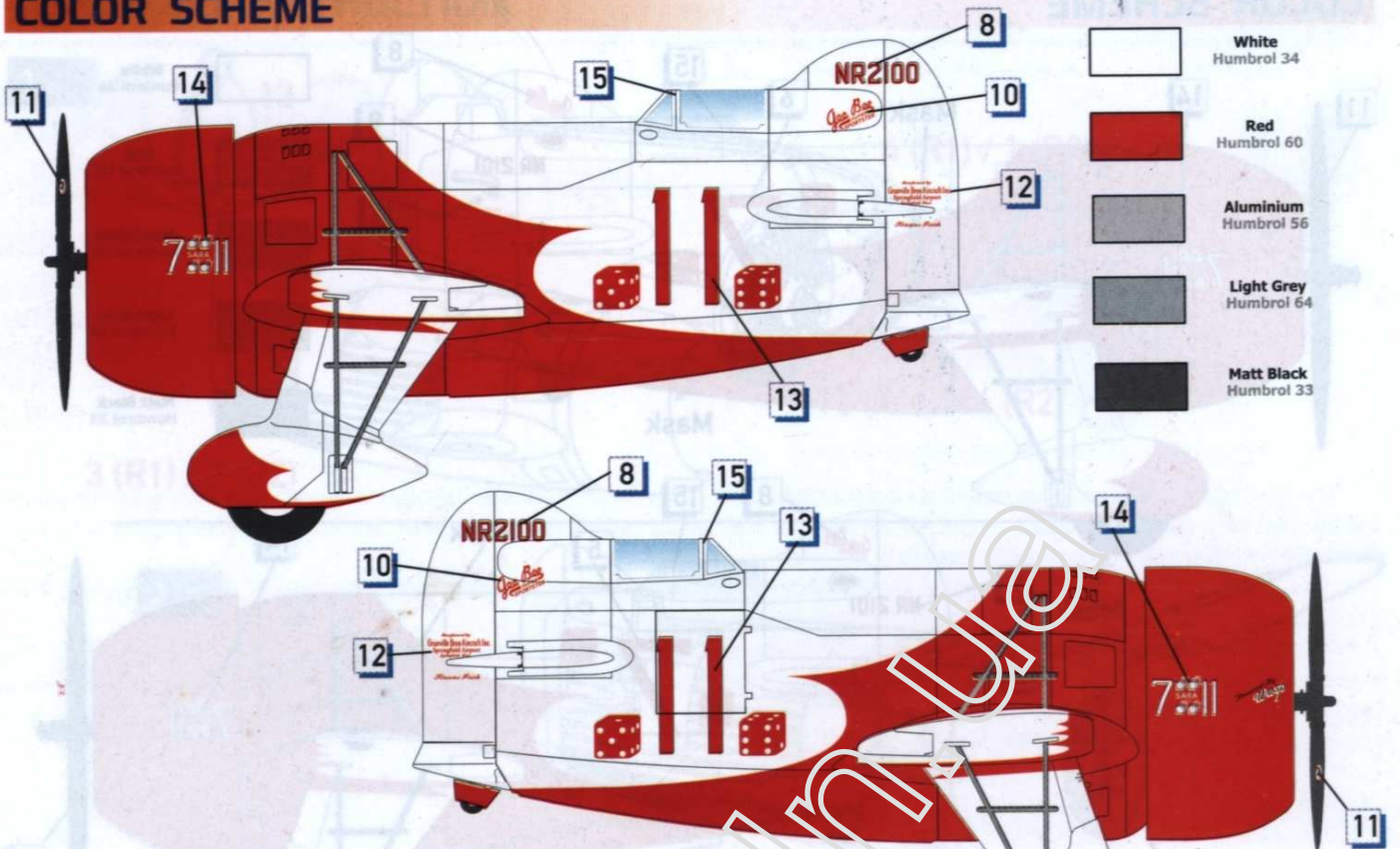

- White**  
Humbrol 34
- Red**  
Humbrol 60
- Aluminium**  
Humbrol 56
- Light Grey**  
Humbrol 64
- Matt Black**  
Humbrol 33

**Gee Bee Super Sportster R-1**

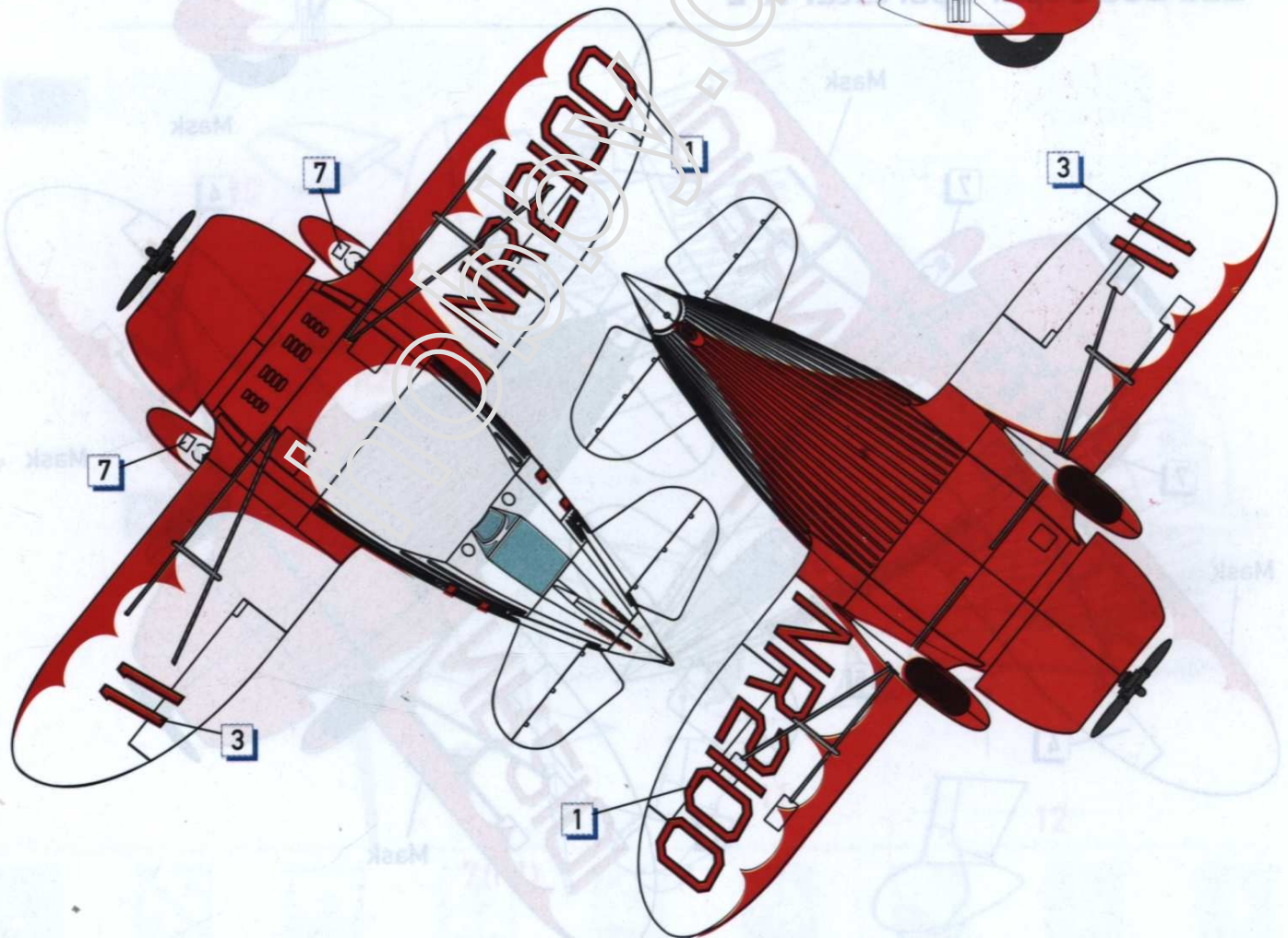

**Gee Bee Super Sportster R-1 & R-2**