



P-63C&E Kingcobra

Dual combo

1/72 SCALE MODEL CONSTRUCTION KIT

Ready to assemble scale models kit.

Contains part for one model.

Model length: 104 mm

Wingspan: 122 mm

Plastic parts: 96

Photoetched parts: 19

The Bell P-63 Kingcobra is an American fighter aircraft developed by Bell Aircraft in World War II from the Bell P-39 Airacobra in an attempt to correct that aircraft's deficiencies.

P-63C Second production series differed from the P-63A by being powered by the updated Allison V-1710-117 engine with a war emergency rating of 1,500 hp (1,120 kW) at sea level and 1,800 hp (1,340 kW) with water injection. The wingspan was reduced by 10 inches (250 mm). A total production run of 1,227 was completed P-63E Essentially similar to the P-63D with the exception of a ventral fin extension and the use of a standard "cab"-style cockpit; only 13 built.

PARTS OF THE MODEL

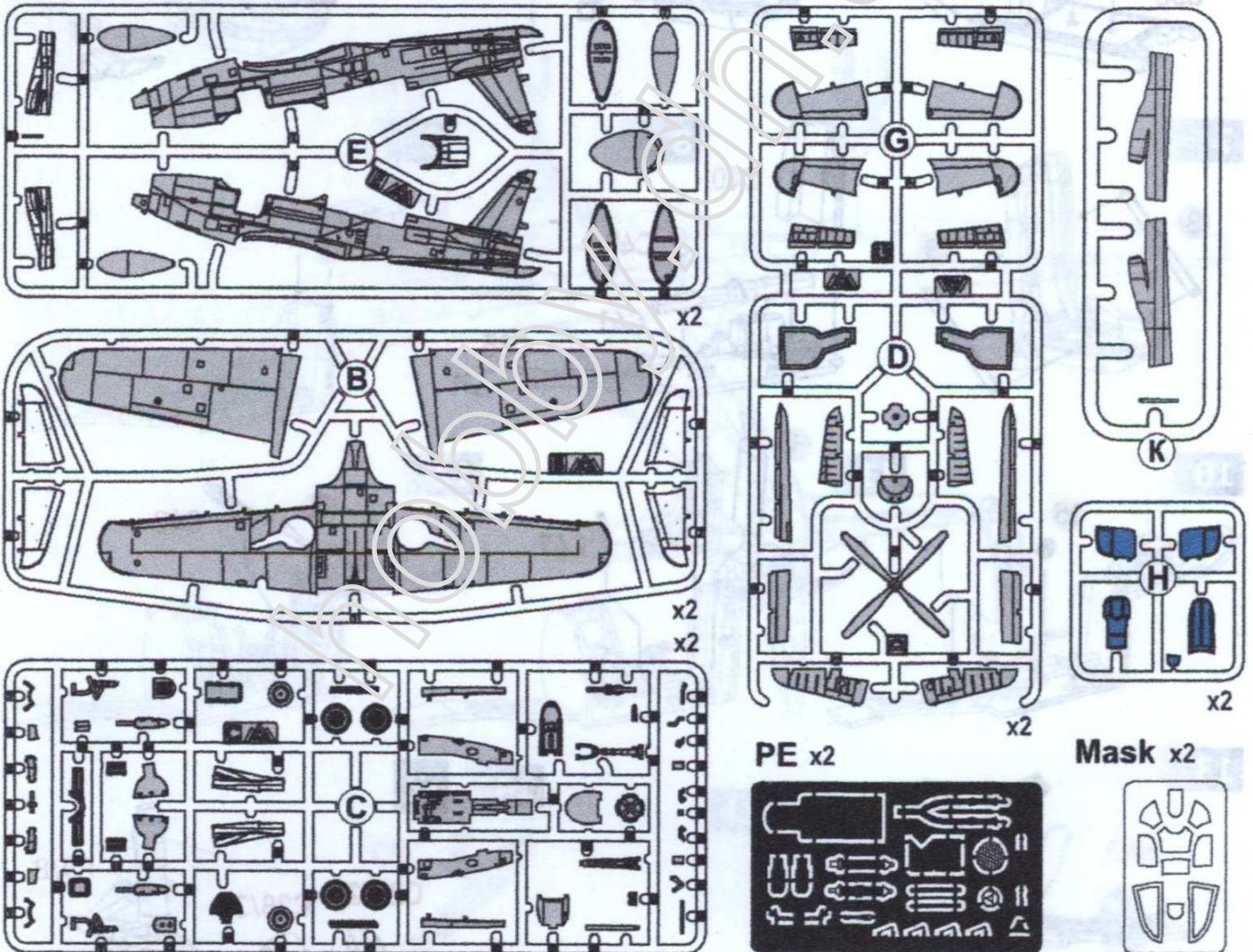

Decal



ASSEMBLY INSTRUCTION

DW 7501 9

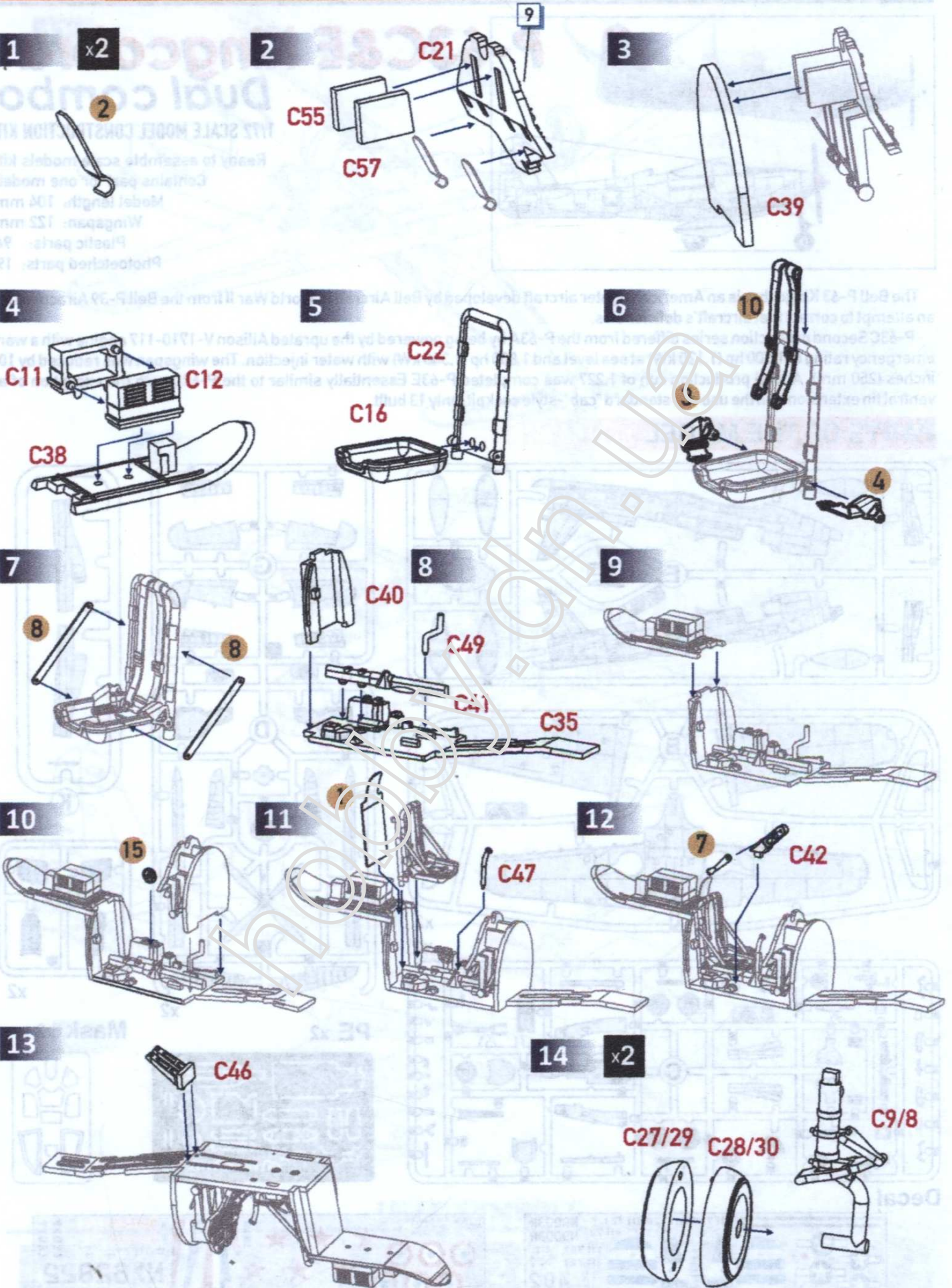

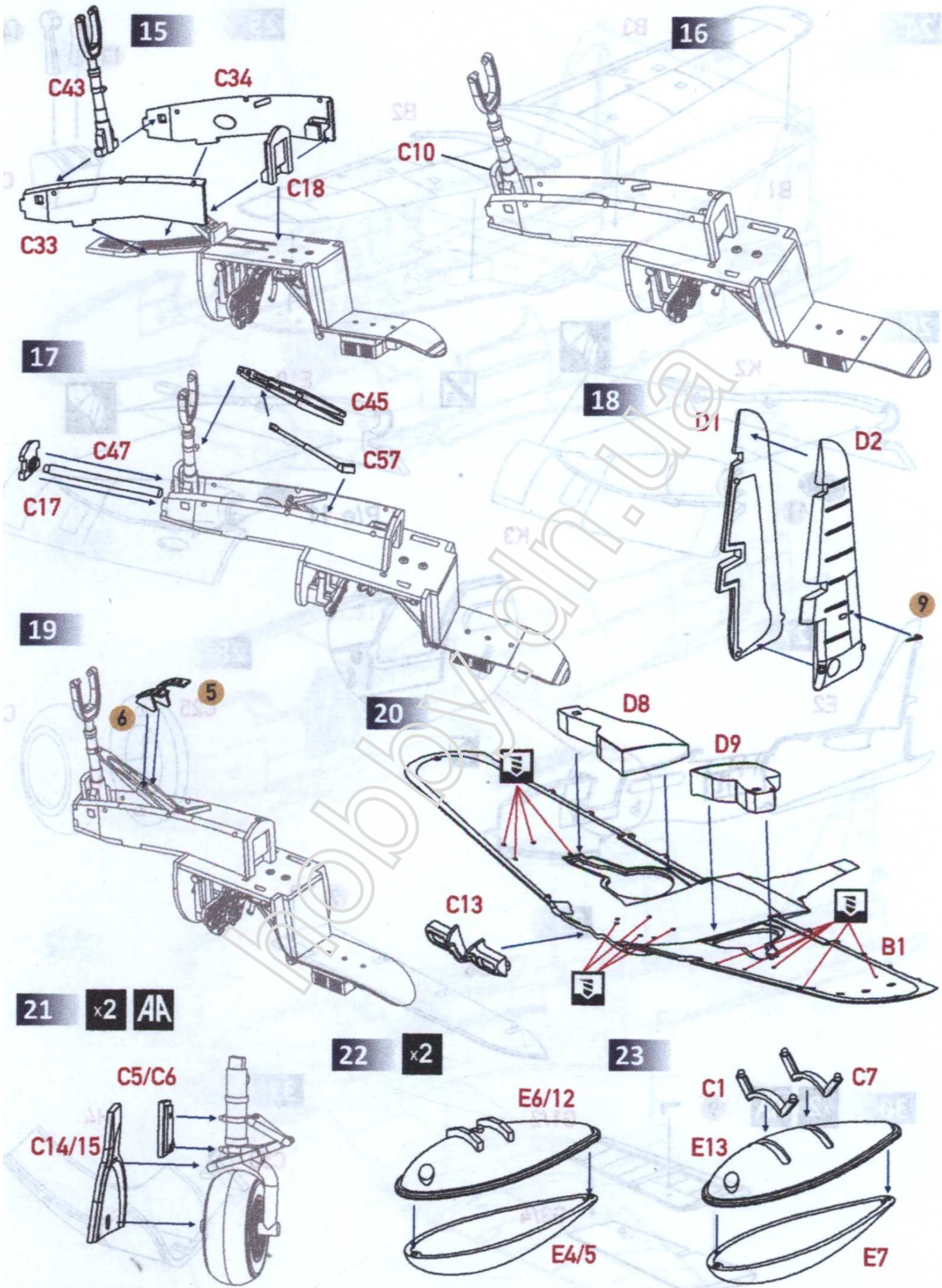

24

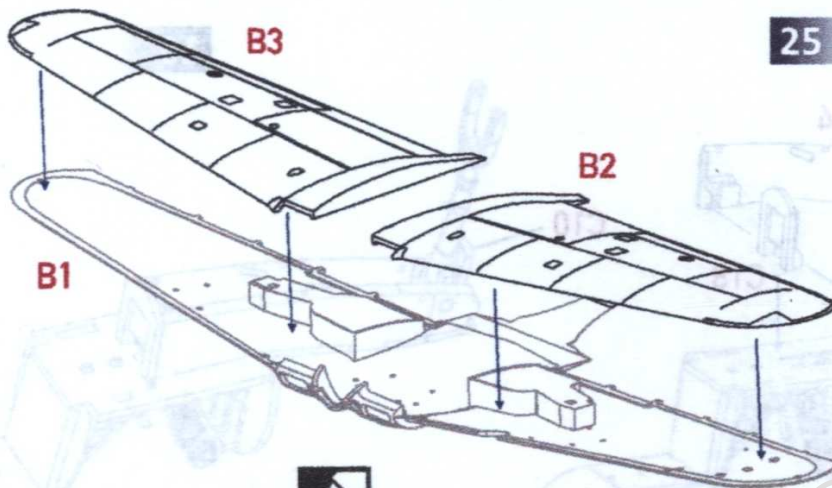

25

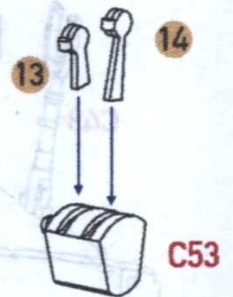

26

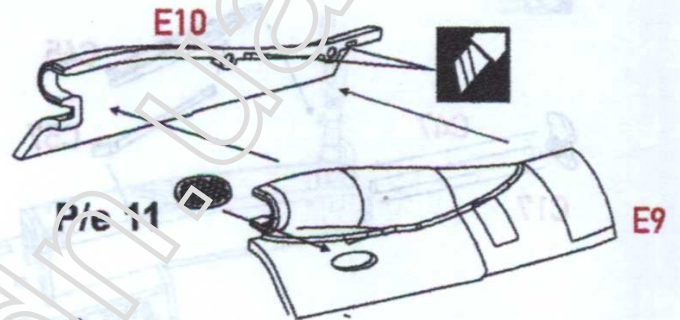
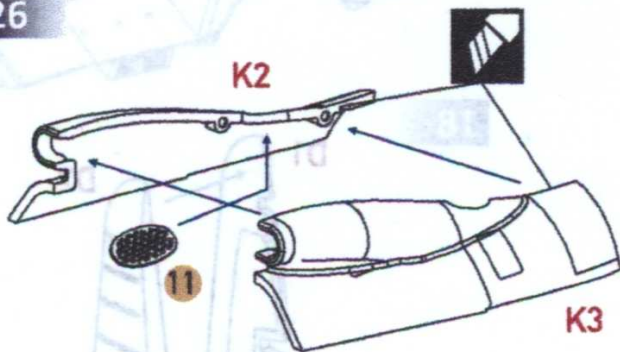

27

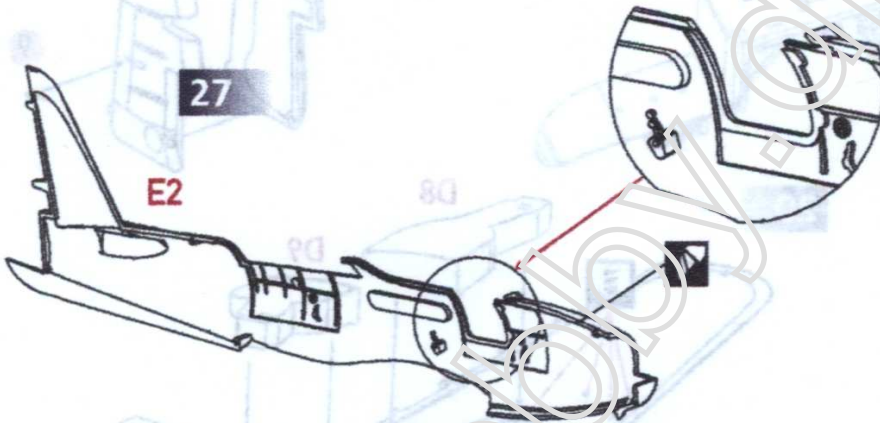

28

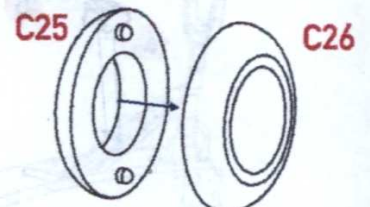

29

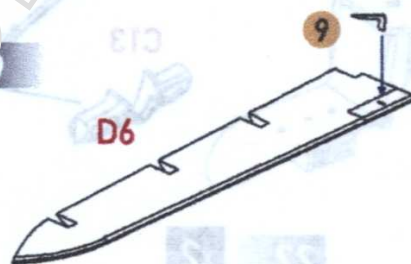

30

x2 AA

9

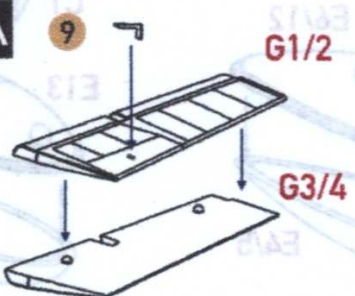

31

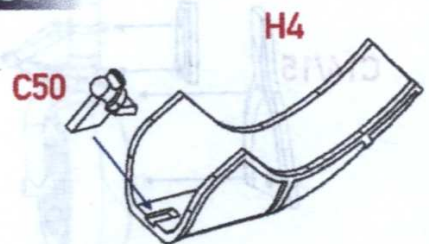

33

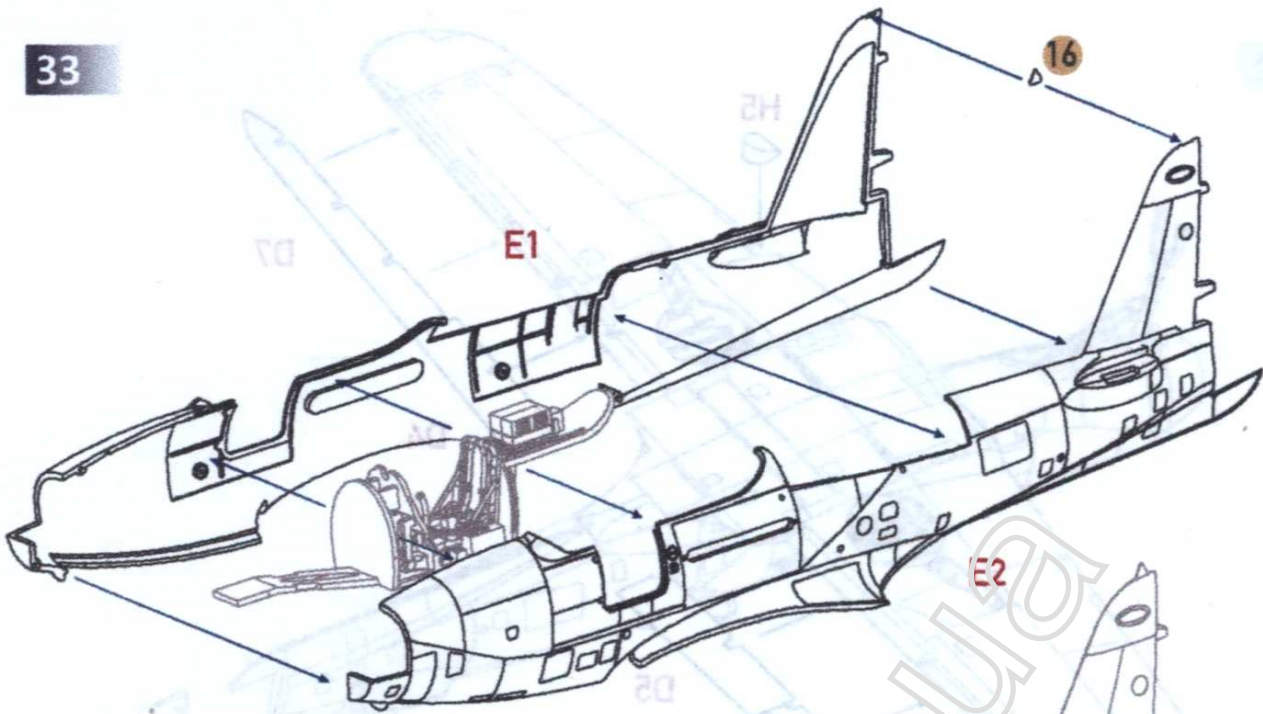

34

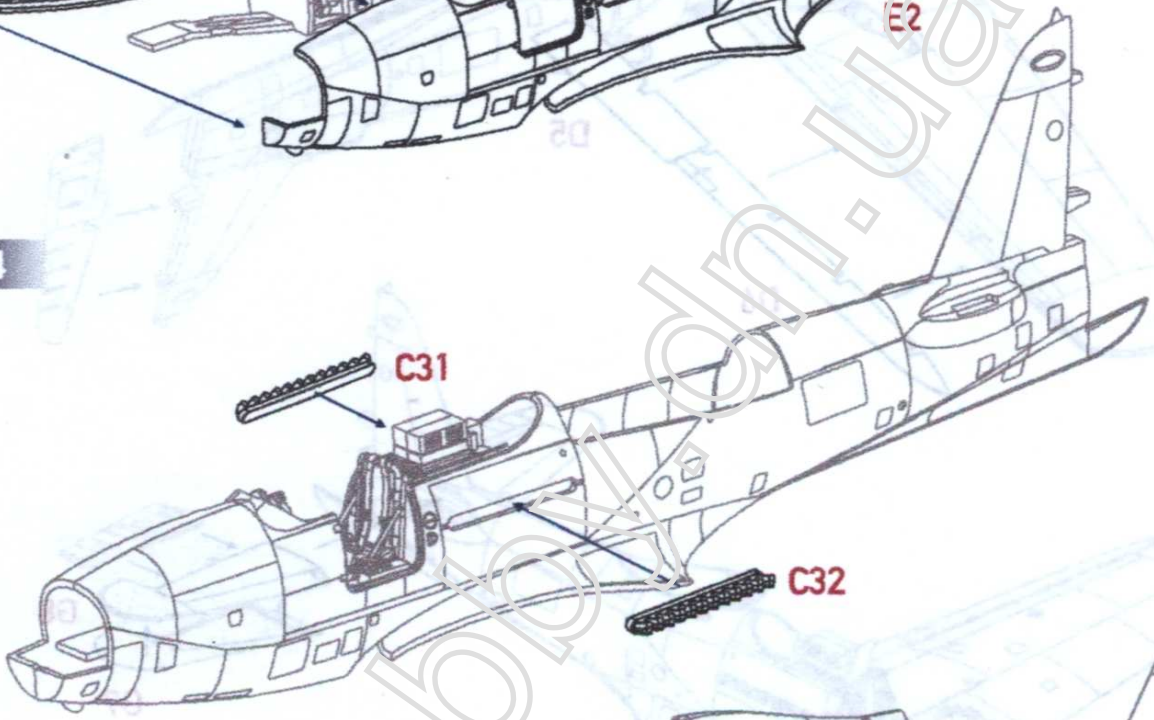

32

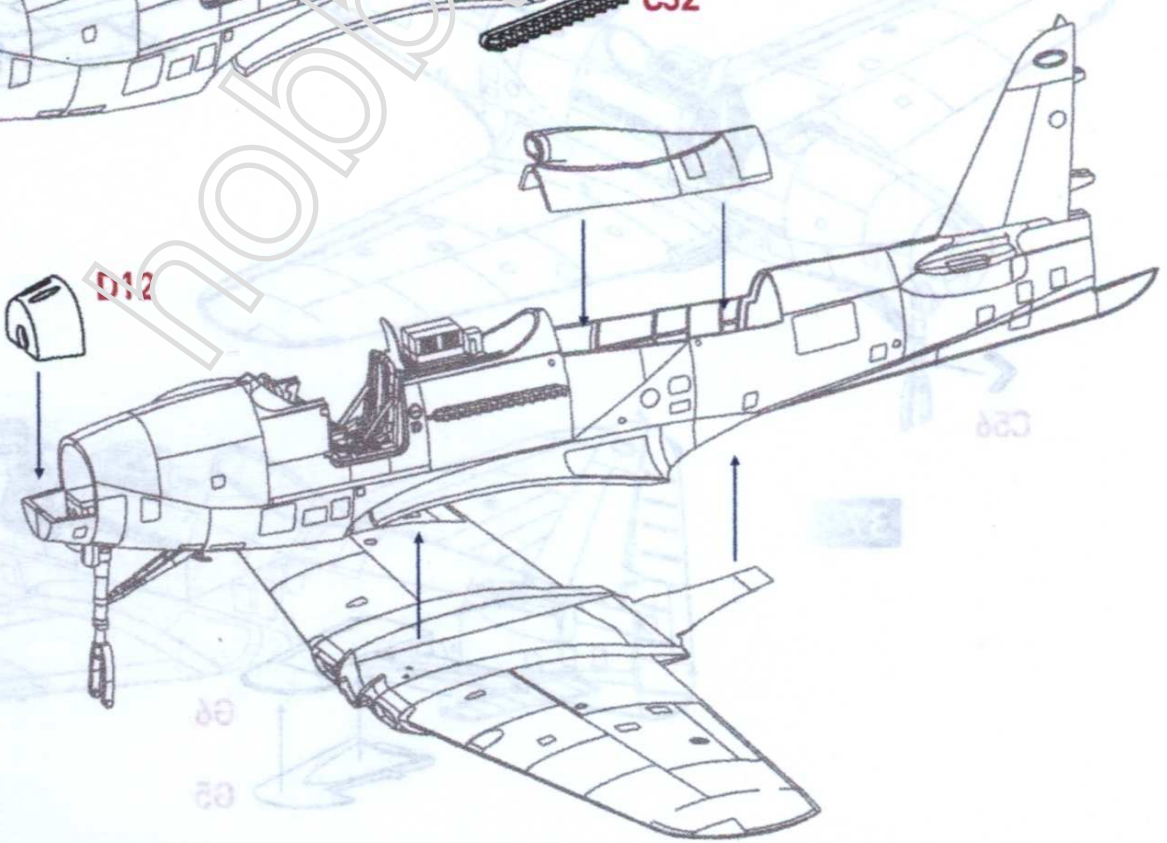

35

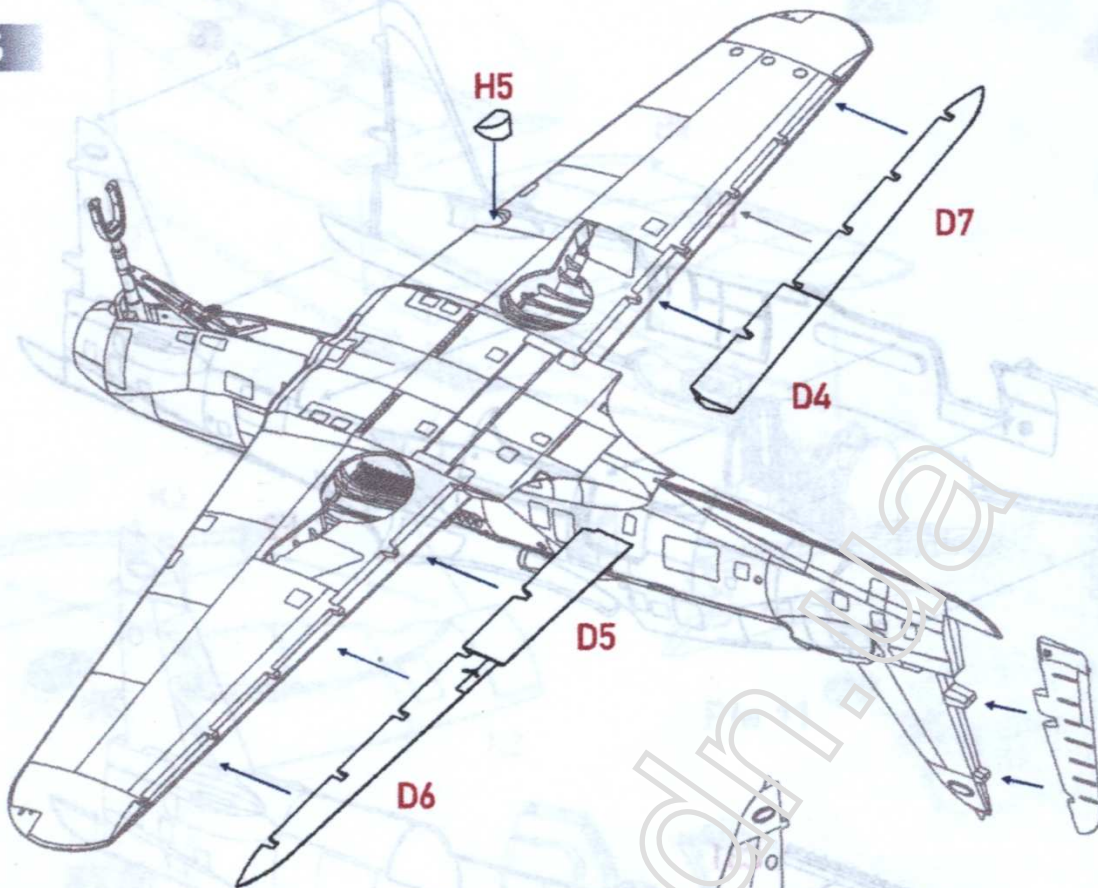

36

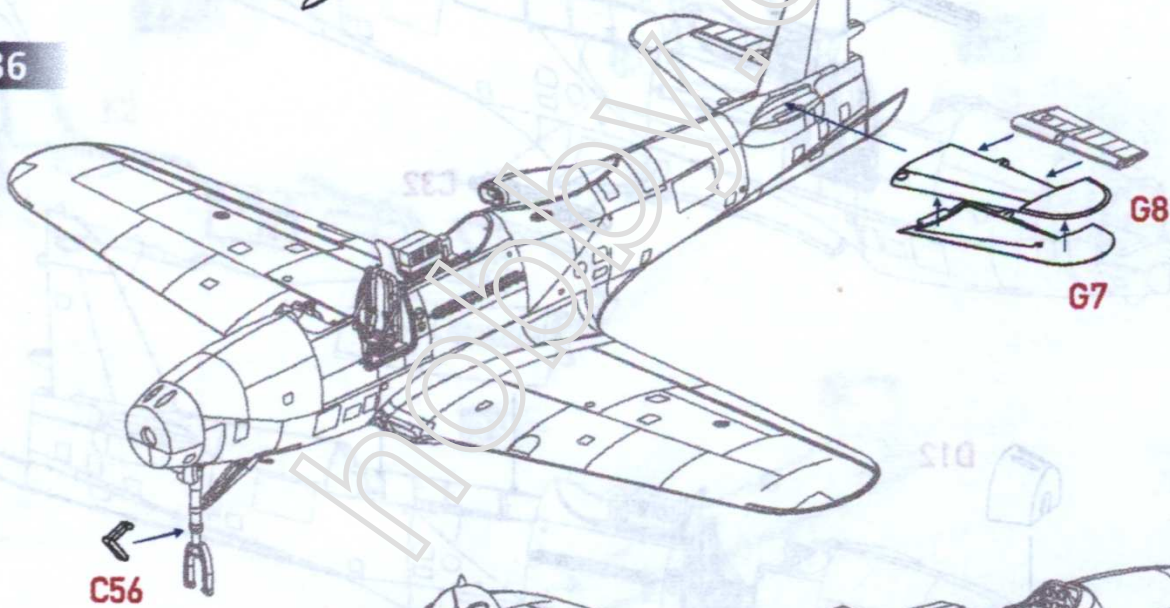

37

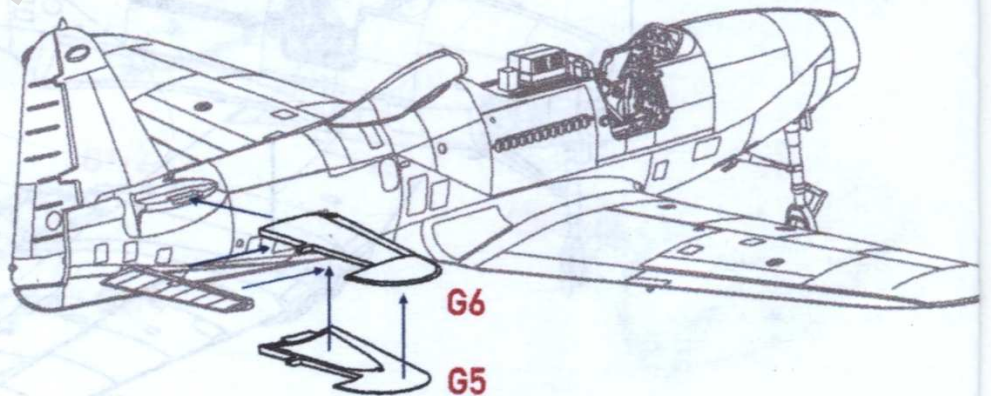

38

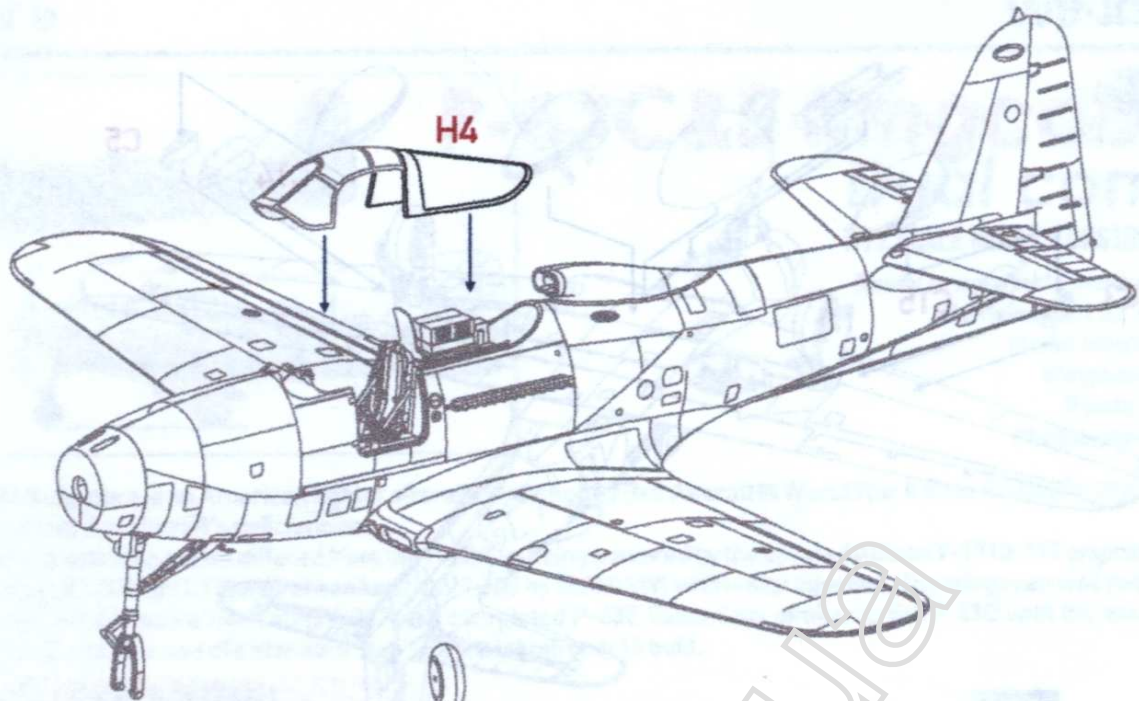

39

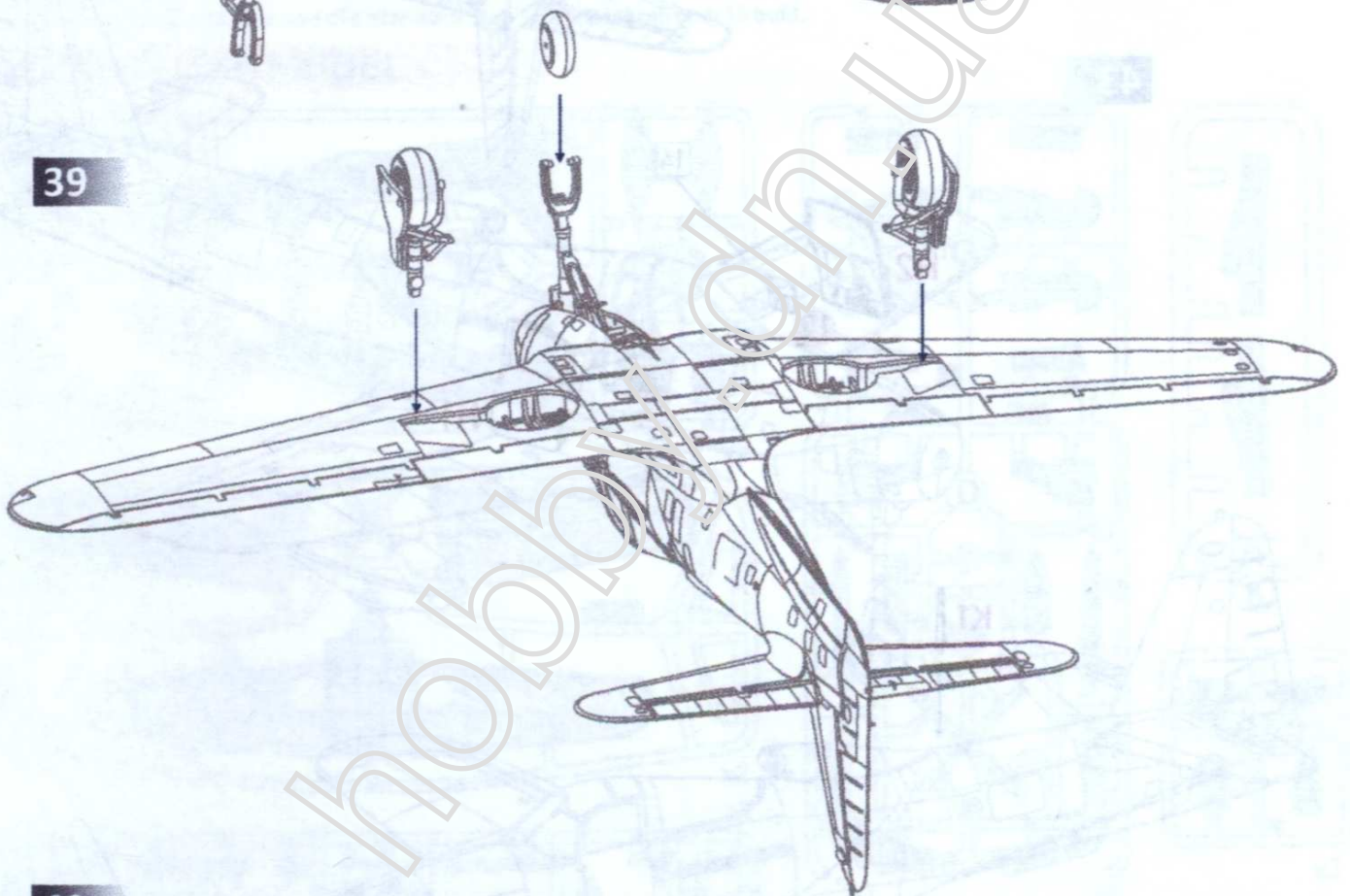

40

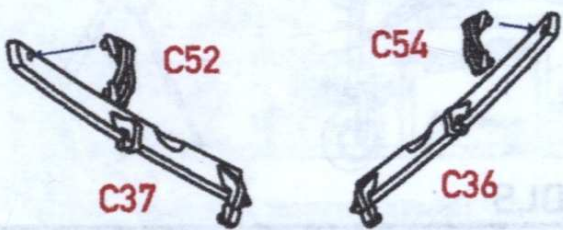

41

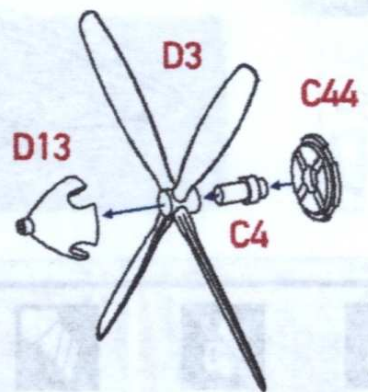

42

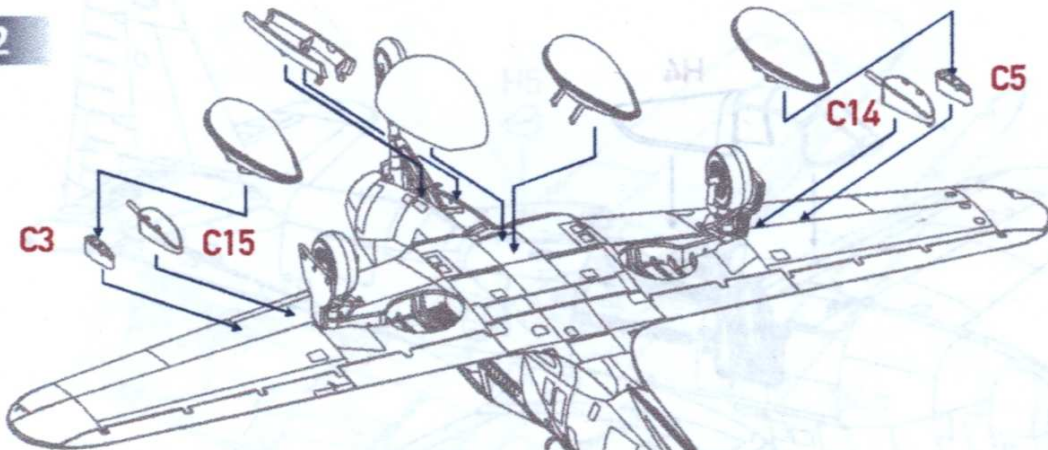

43

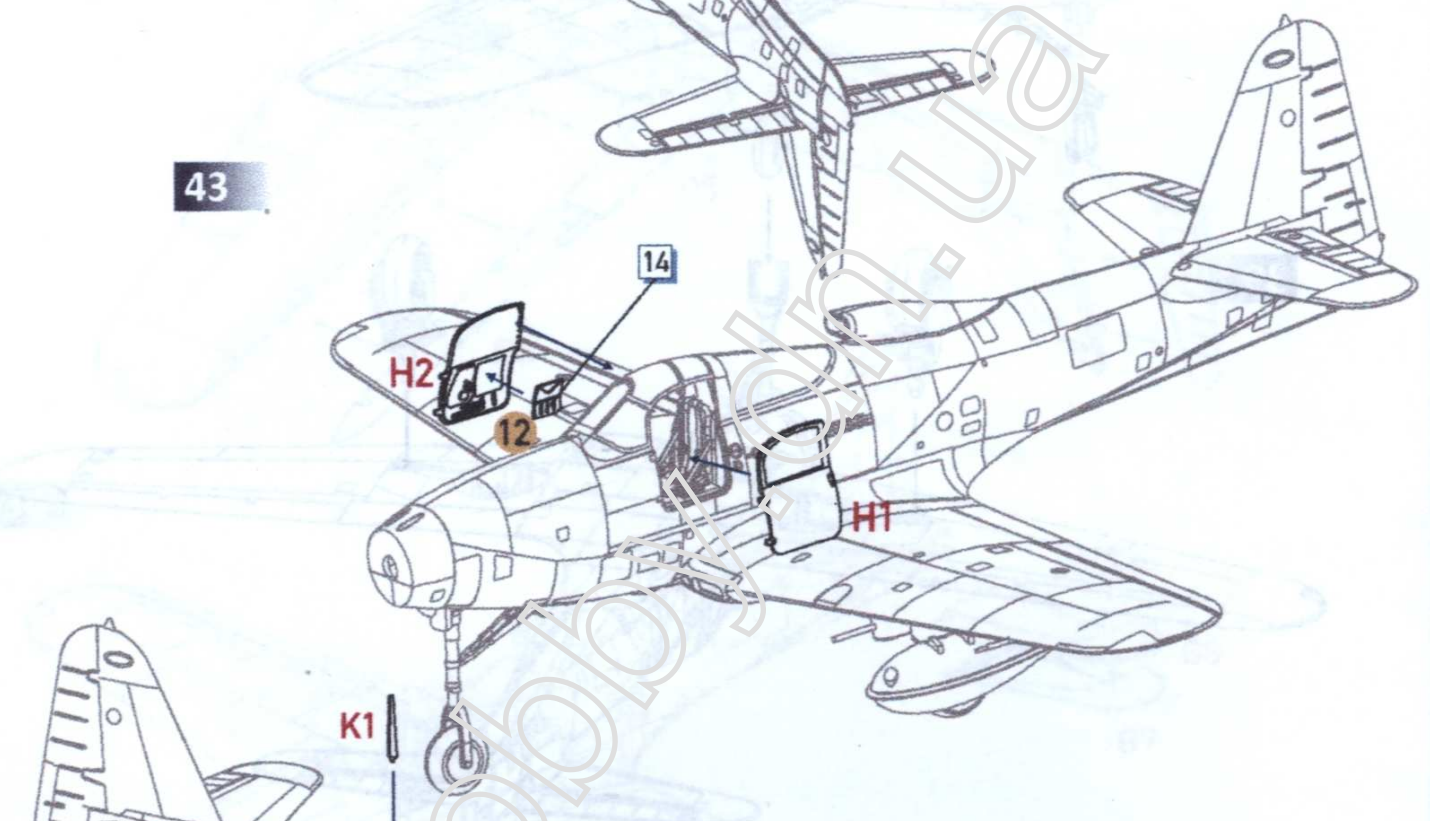

44

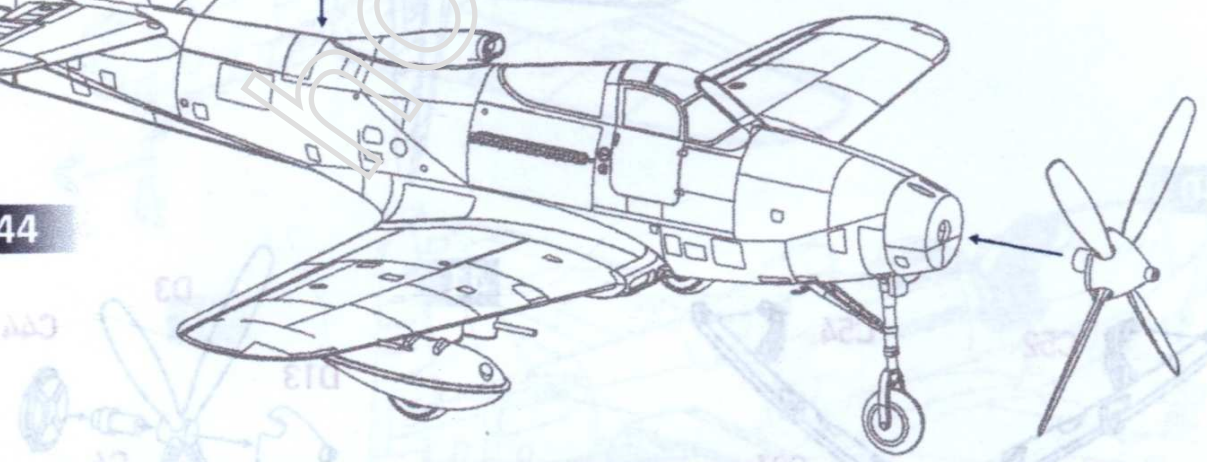

USED SYMBOLS

- CEMENT
- DON'T CEMENT
- REMOVE
- SYMMETRICAL
- MULTIPLE
- BEND
- OPEN WHOLE
- VARIANTS
- TO PAINT

COLOR SCHEME

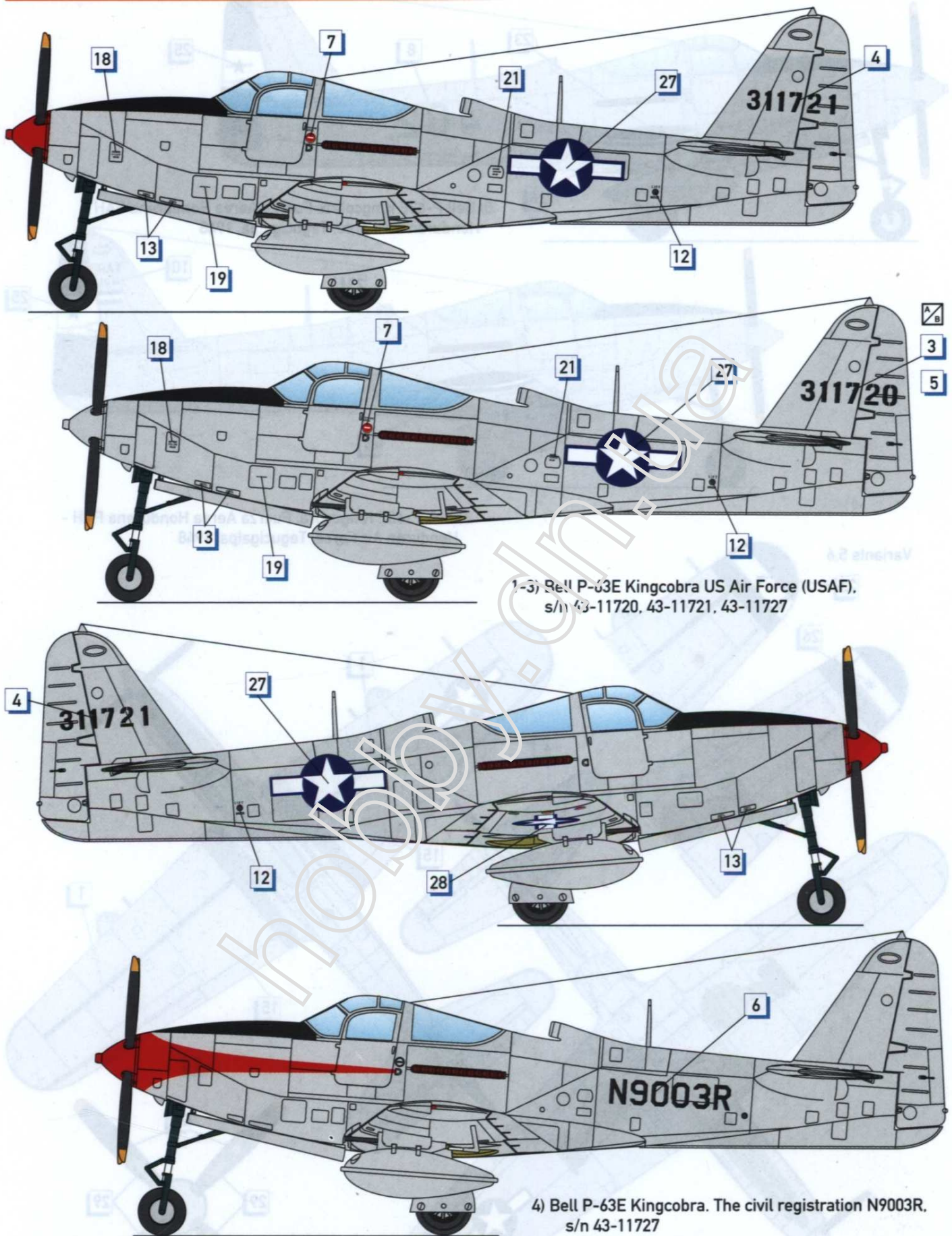

1-3) Bell P-63E Kingcobra US Air Force (USAF).
s/n 43-11720, 43-11721, 43-11727

4) Bell P-63E Kingcobra. The civil registration N9003R.
s/n 43-11727

Aluminium Humbrol 56	Red Humbrol 60	Interior Green	Matt Black Humbrol 56	Orange Humbrol 82	Green Humbrol 120	Rust Humbrol 113	Yellow Humbrol 24	Olive Drab Humbrol 66

Bell P-63E Kingcobra

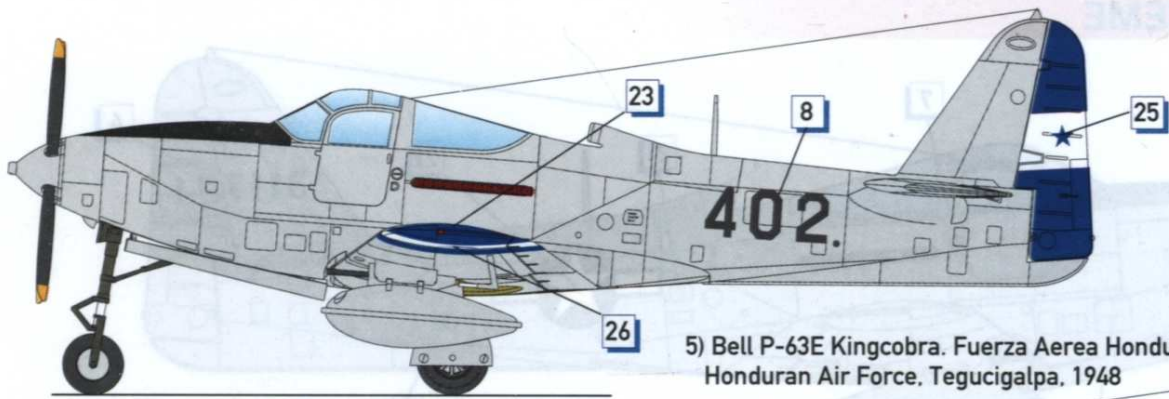

5) Bell P-63E Kingcobra. Fuerza Aerea Hondurena FAH - Honduran Air Force, Tegucigalpa, 1948

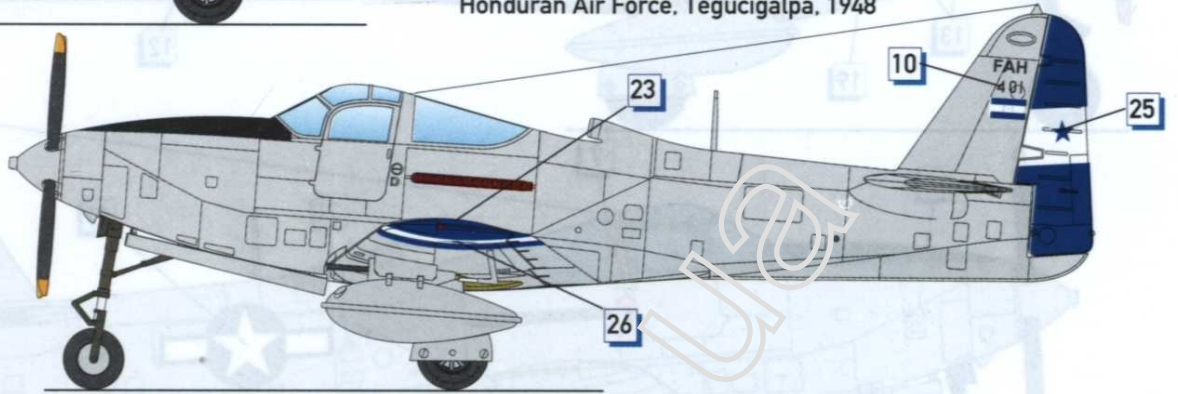

6) Bell P-63E Kingcobra. Fuerza Aerea Hondurena FAH - Honduran Air Force, Tegucigalpa, 1948

Variants 5,6

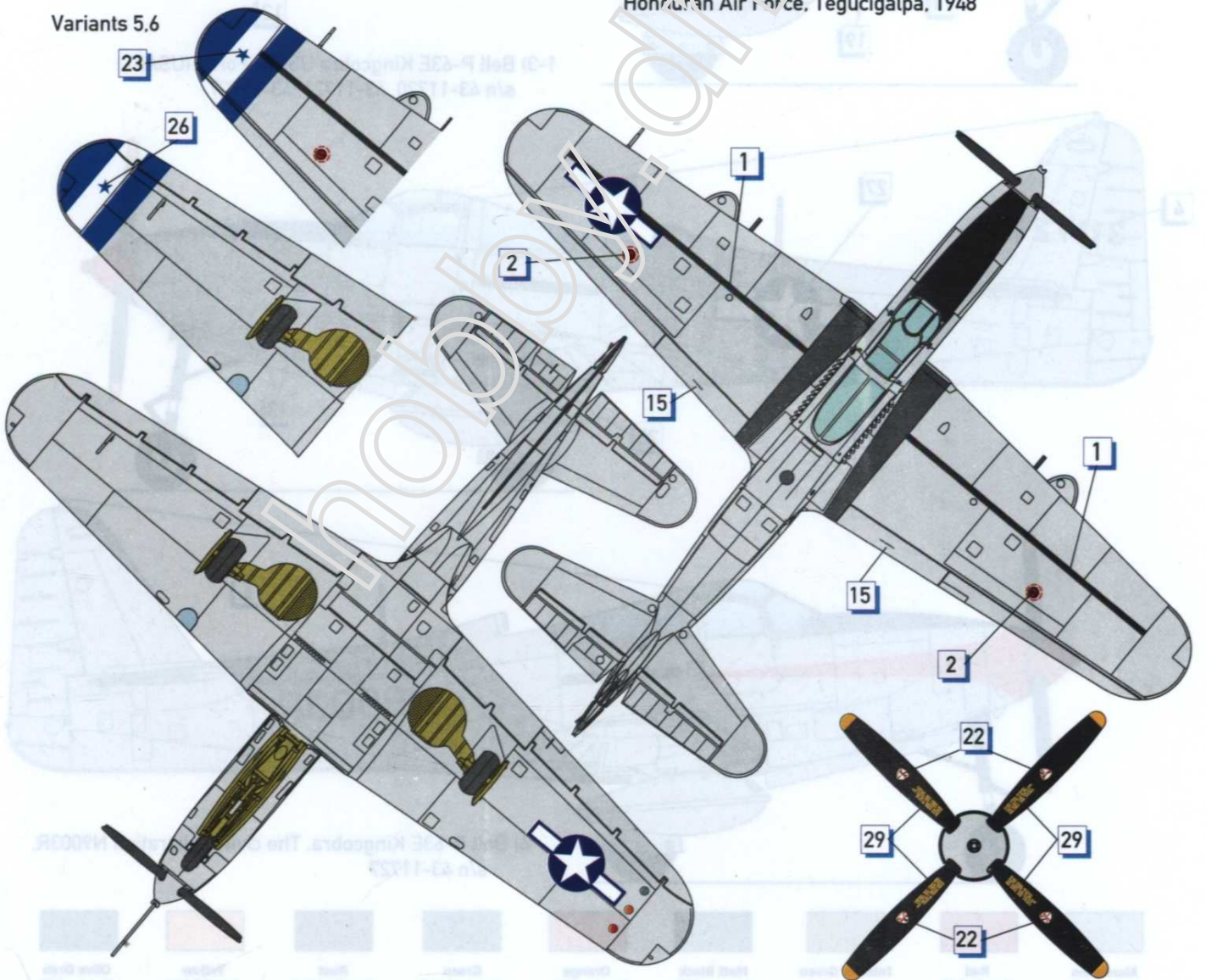

Bell P-63E Kingcobra

COLOR SCHEME

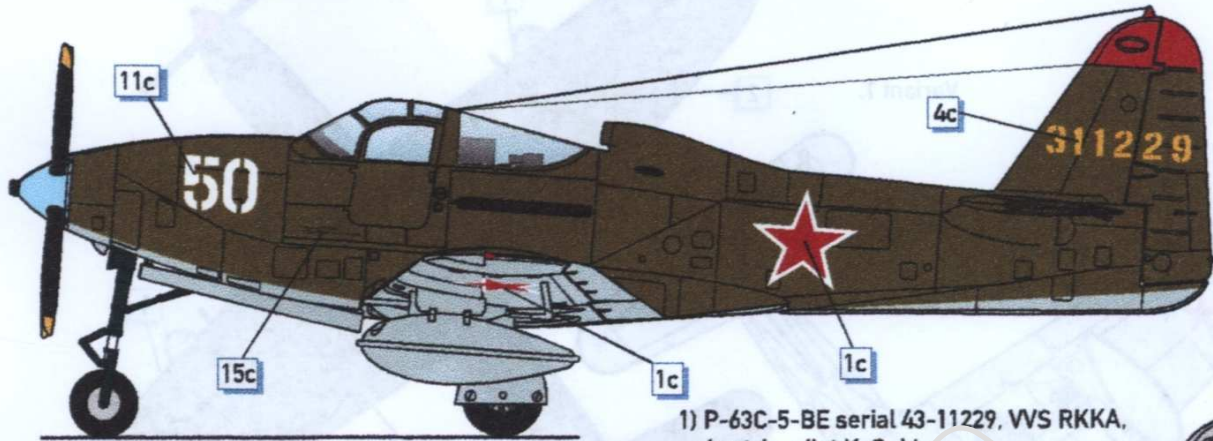

1) P-63C-5-BE serial 43-11229, VWS RKKA, Austria, pilot K. Sukhyj

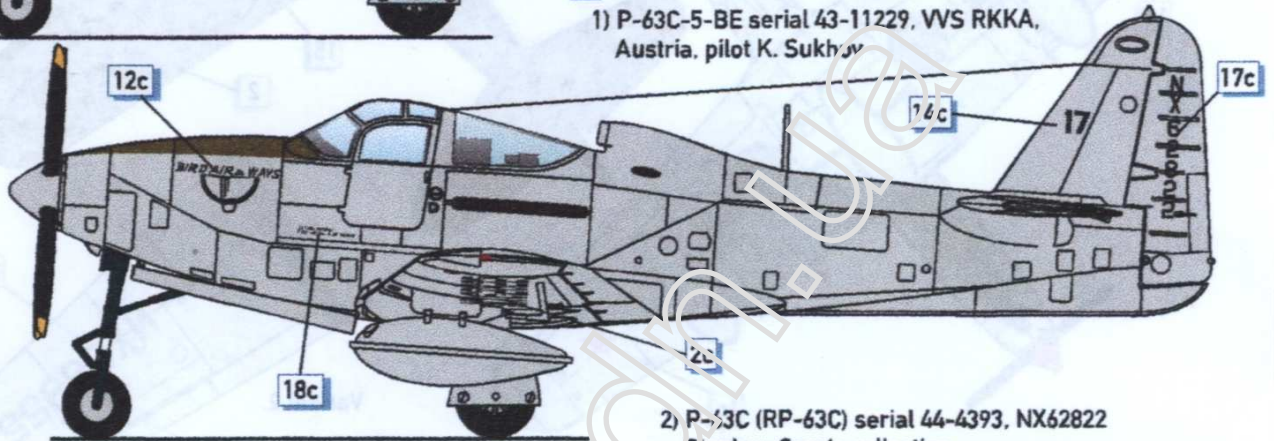

2) P-63C (RP-63C) serial 44-4393, NX62822 Stephen Grey's collection

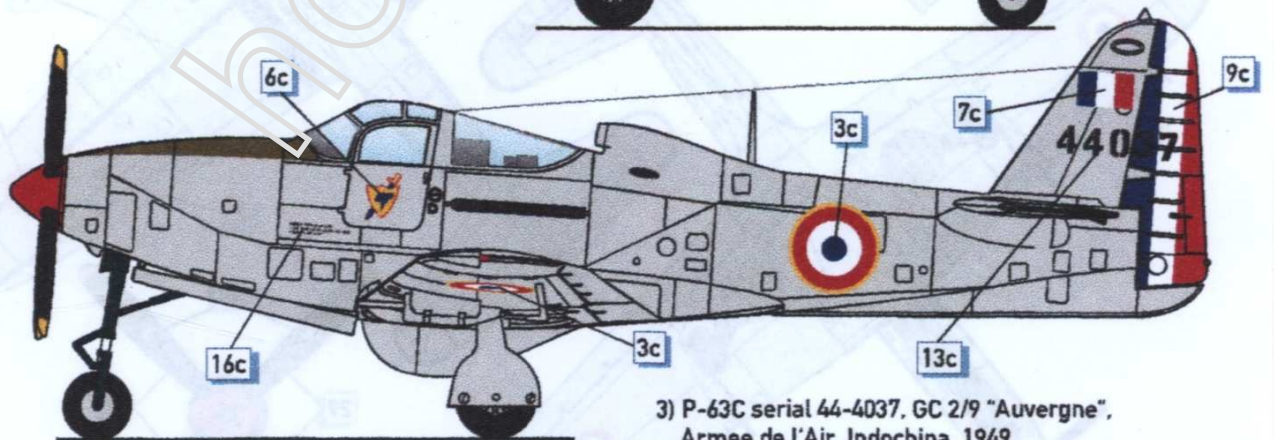
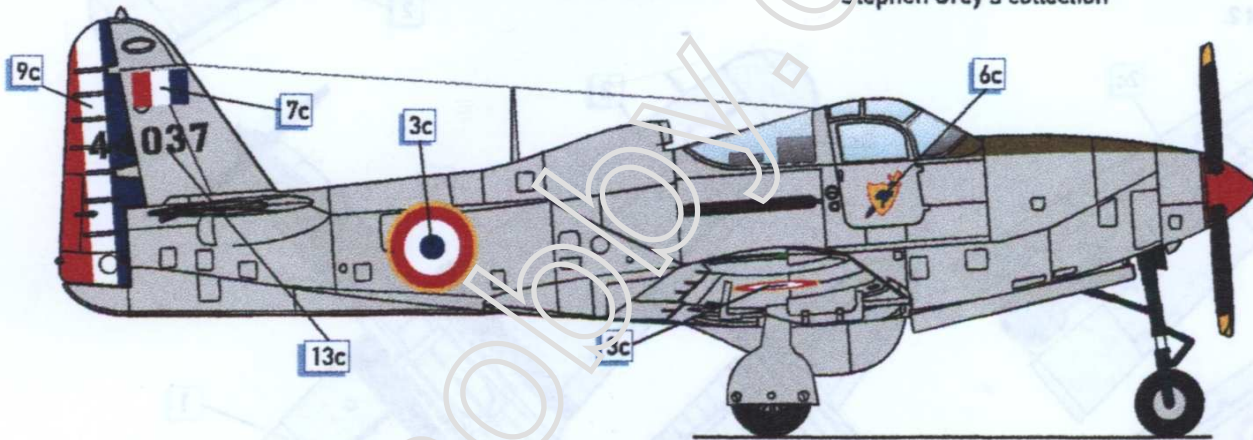

3) P-63C serial 44-4037, GC 2/9 "Auvergne", Armee de l'Air, Indochina, 1949

								
Aluminum Humbrol 56	Red Humbrol 60	Interior Green	Matt Black Humbrol 56	Light blue Humbrol 65	Green Humbrol 120	Rust Humbrol 113	Yellow Humbrol 24	Olive Drab Humbrol 66

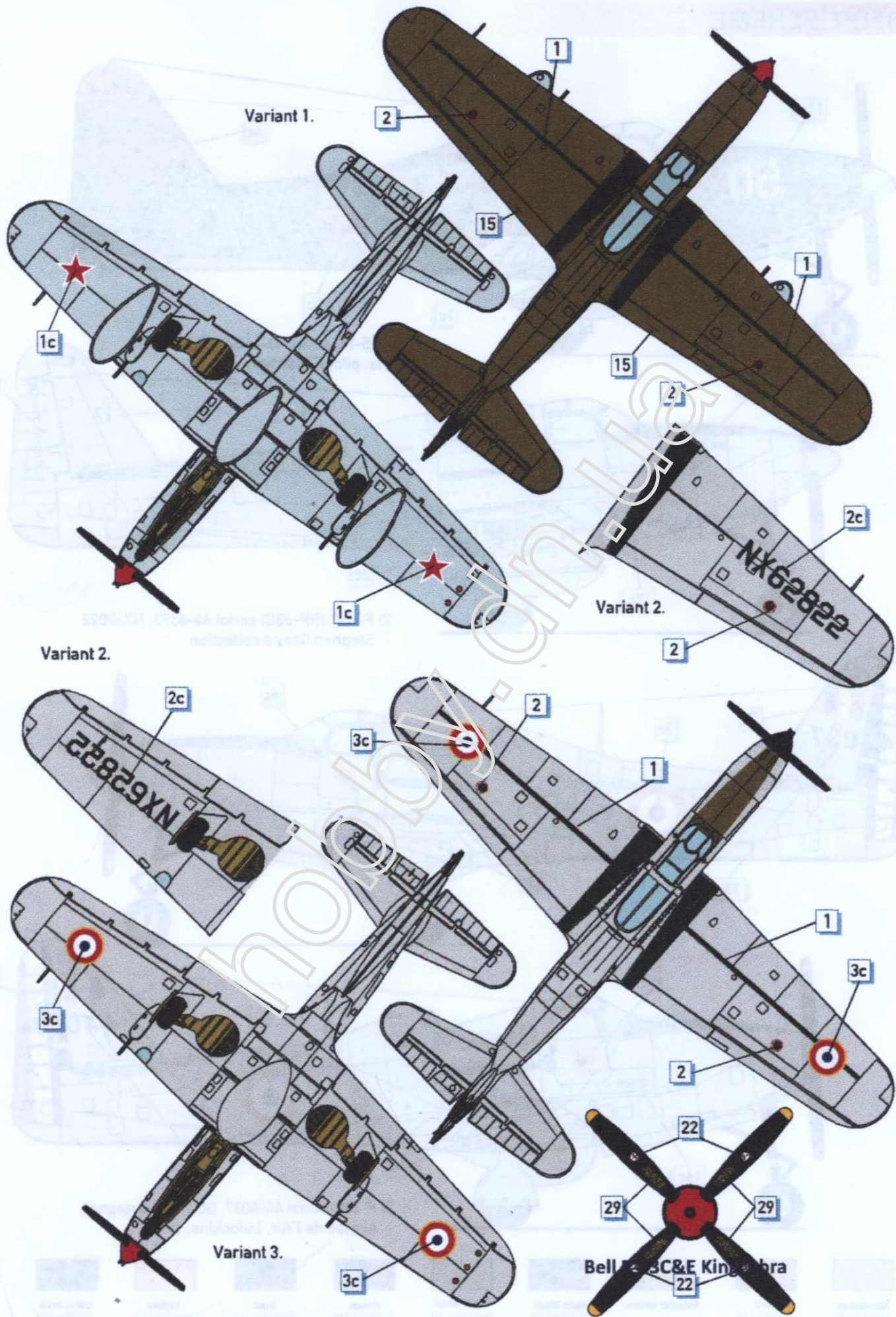

Bell P-63C&E Kingcobra