

Percival Proctor Mk.III



1/72 SCALE MODEL CONSTRUCTION KIT

Ready to assemble scale models kit.

Contains part for one model.

Model length: 112 mm

Wingspan: 168 mm

Plastic parts: 57

Photoetched parts: 47

The Proctor was developed from the Percival Vega Gull in response to Air Ministry Specification 20/38 for a radio trainer and communications aircraft. A total of 1143 pcs were built. Mod. P.34 Proctor III - three-seat radio trainer for Bomber Command radio operators, 437 built.

The Percival Proctor was created on the basis of the original drawings, which were given to the company of Dora Wings by **Mr. John Adams (Aeroclub company)**. He also advised the designers of the company, and provided help. The team of Dora Wings expresses great gratitude to John Adams for help and advice. You're the man John!

PARTS OF THE MODEL

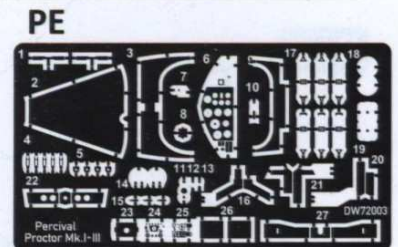
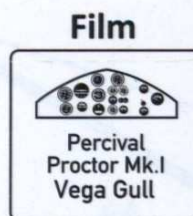
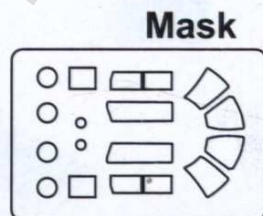
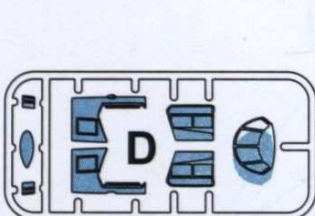
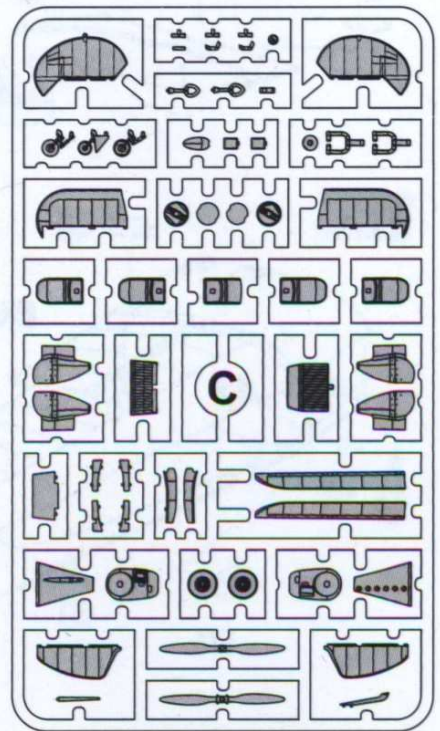
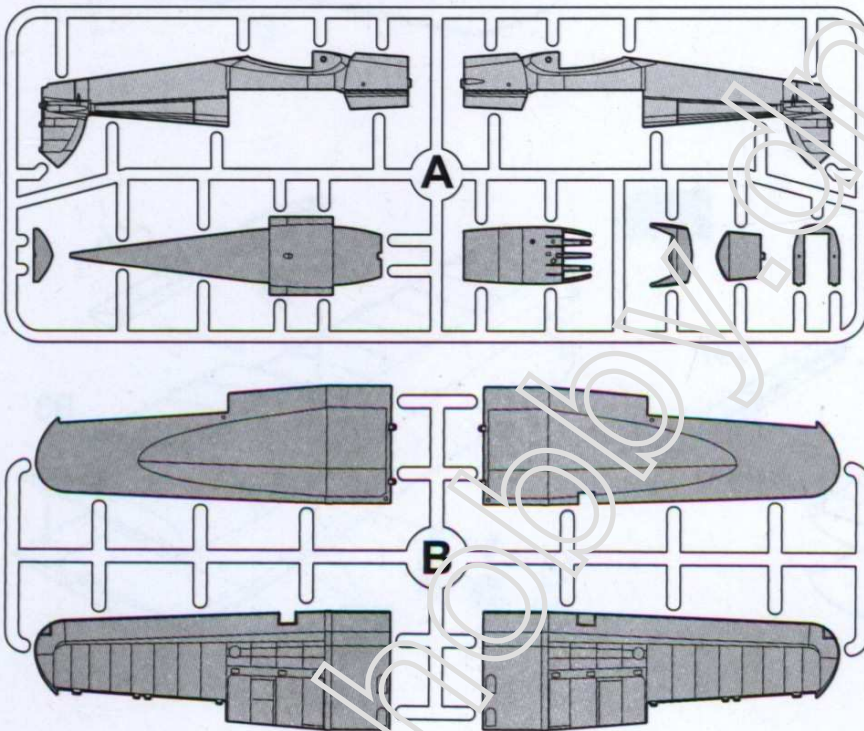

USED SYMBOLS



ASSEMBLY INSTRUCTION

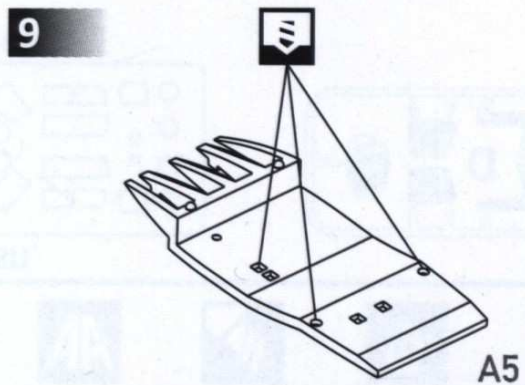
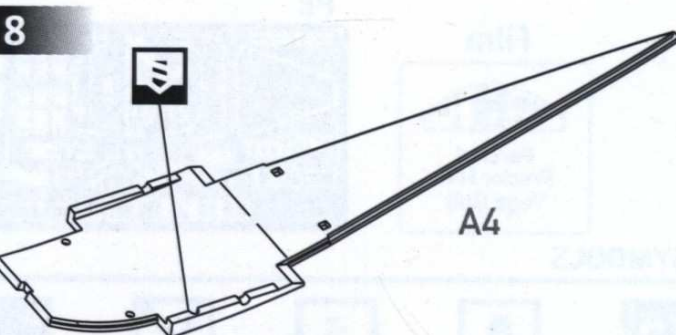
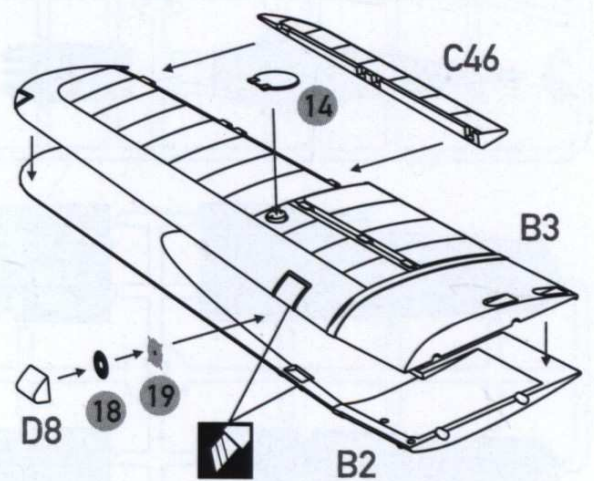
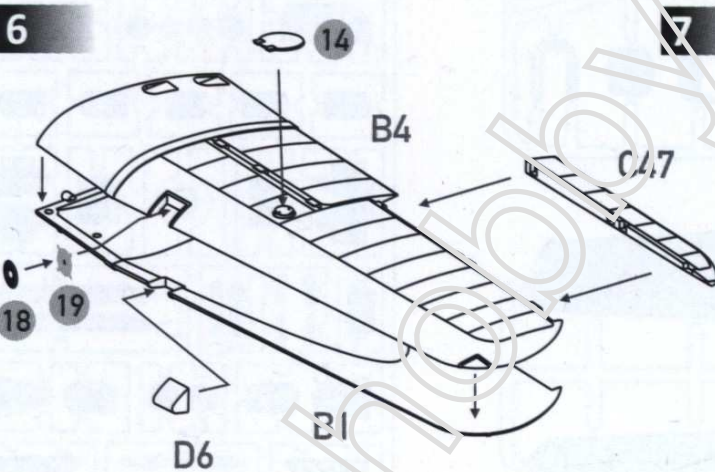
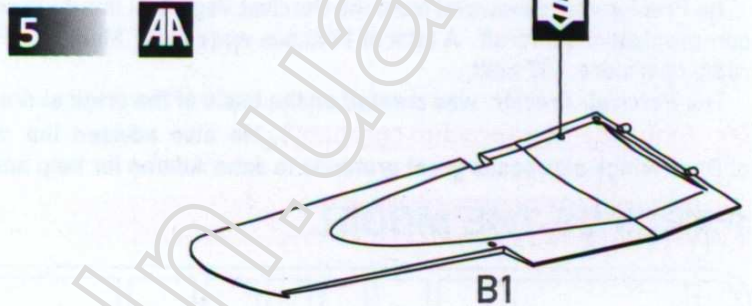
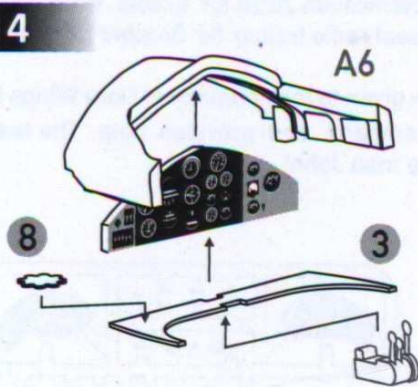
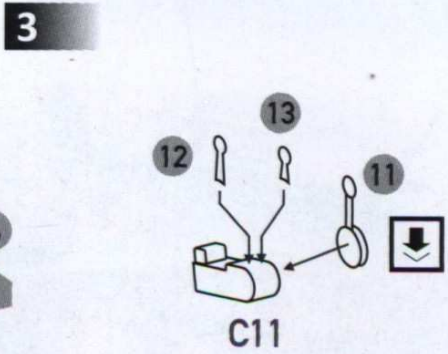
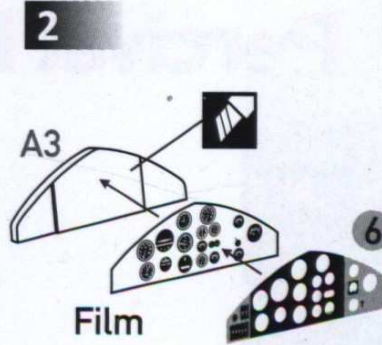
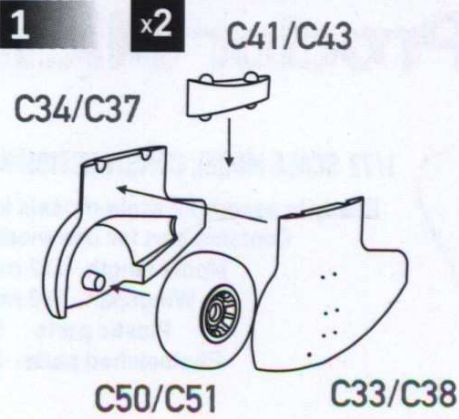

10 x2

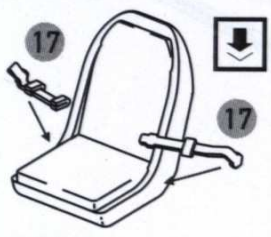

C28/29

11



C30

12

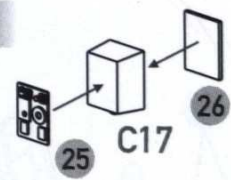

C17

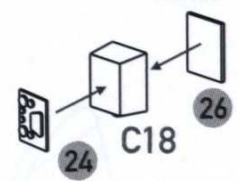

C18

13

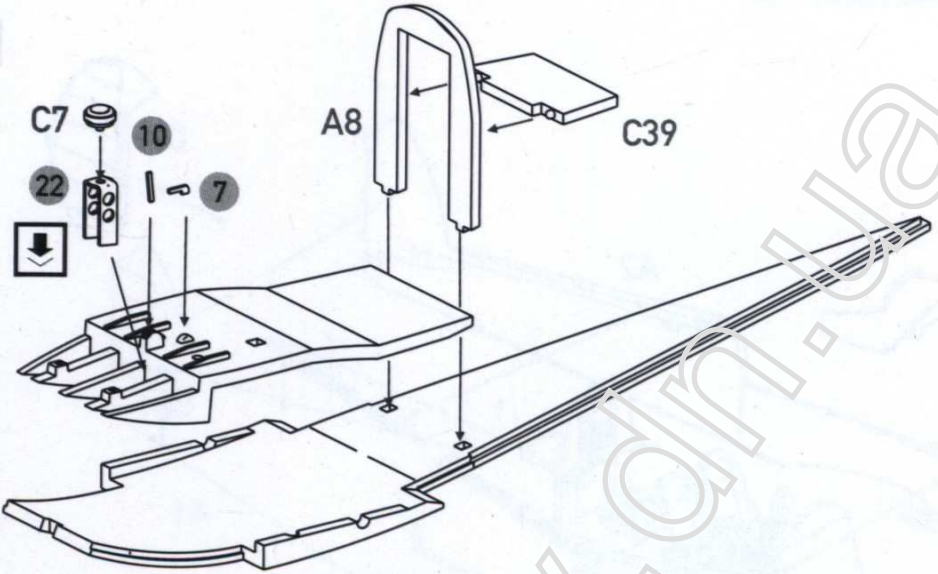

14

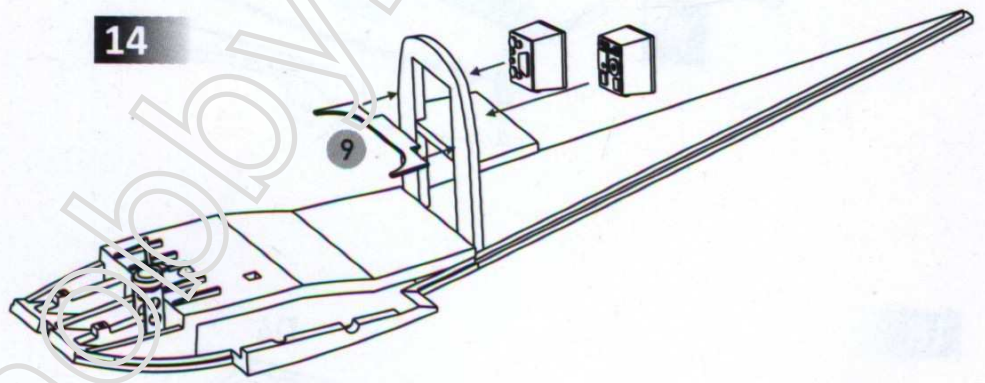

15

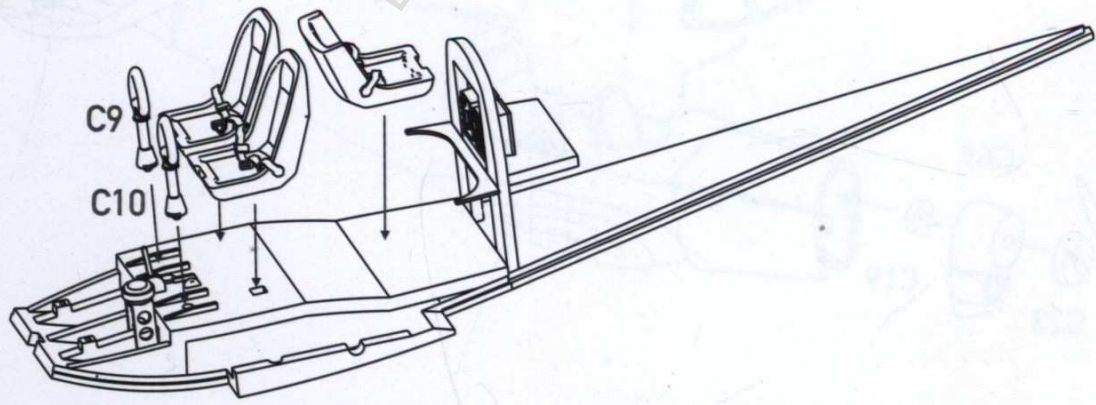

16

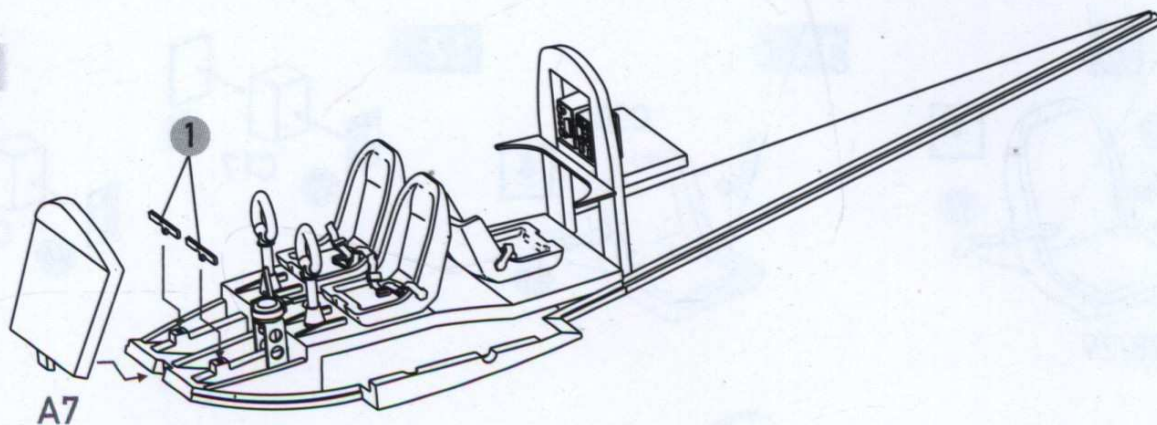

17

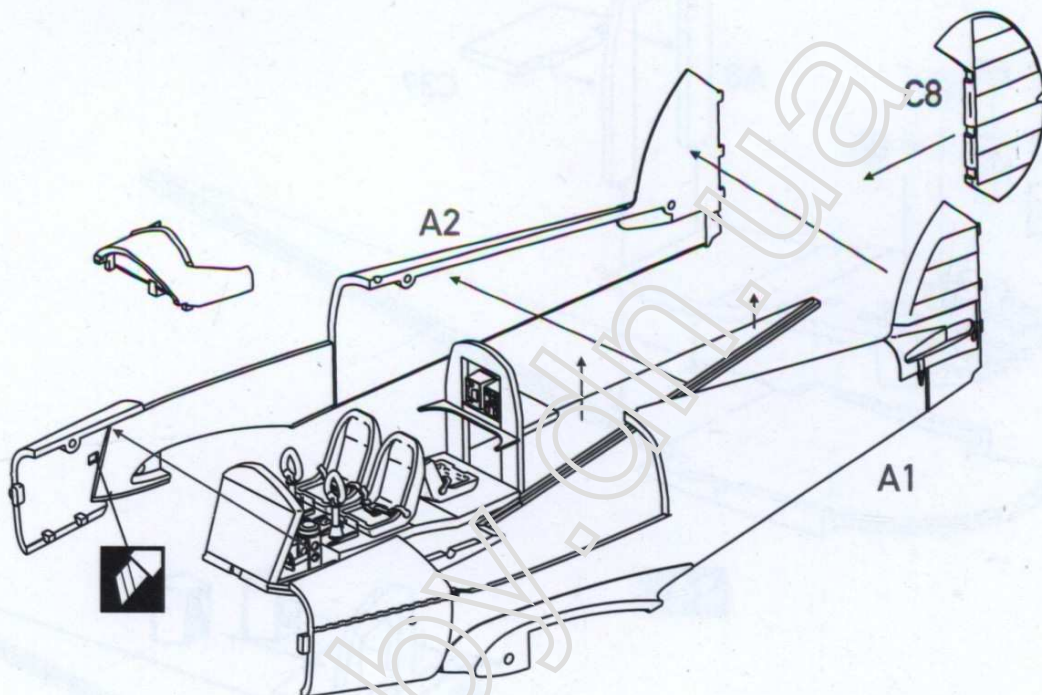

18

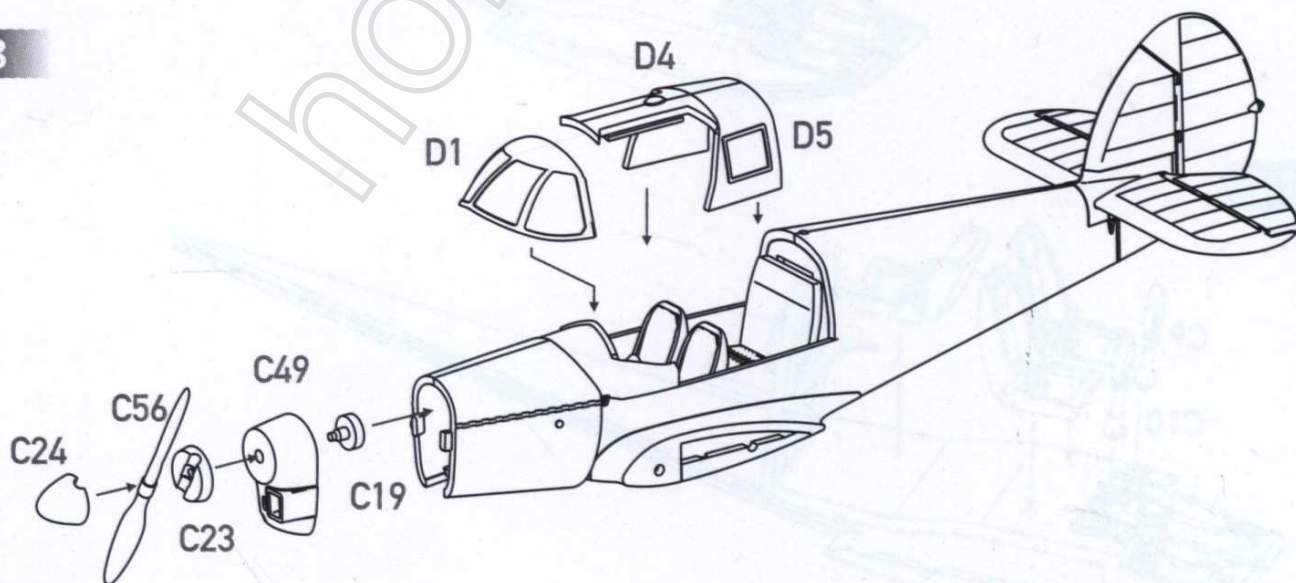

COLOR SCHEME

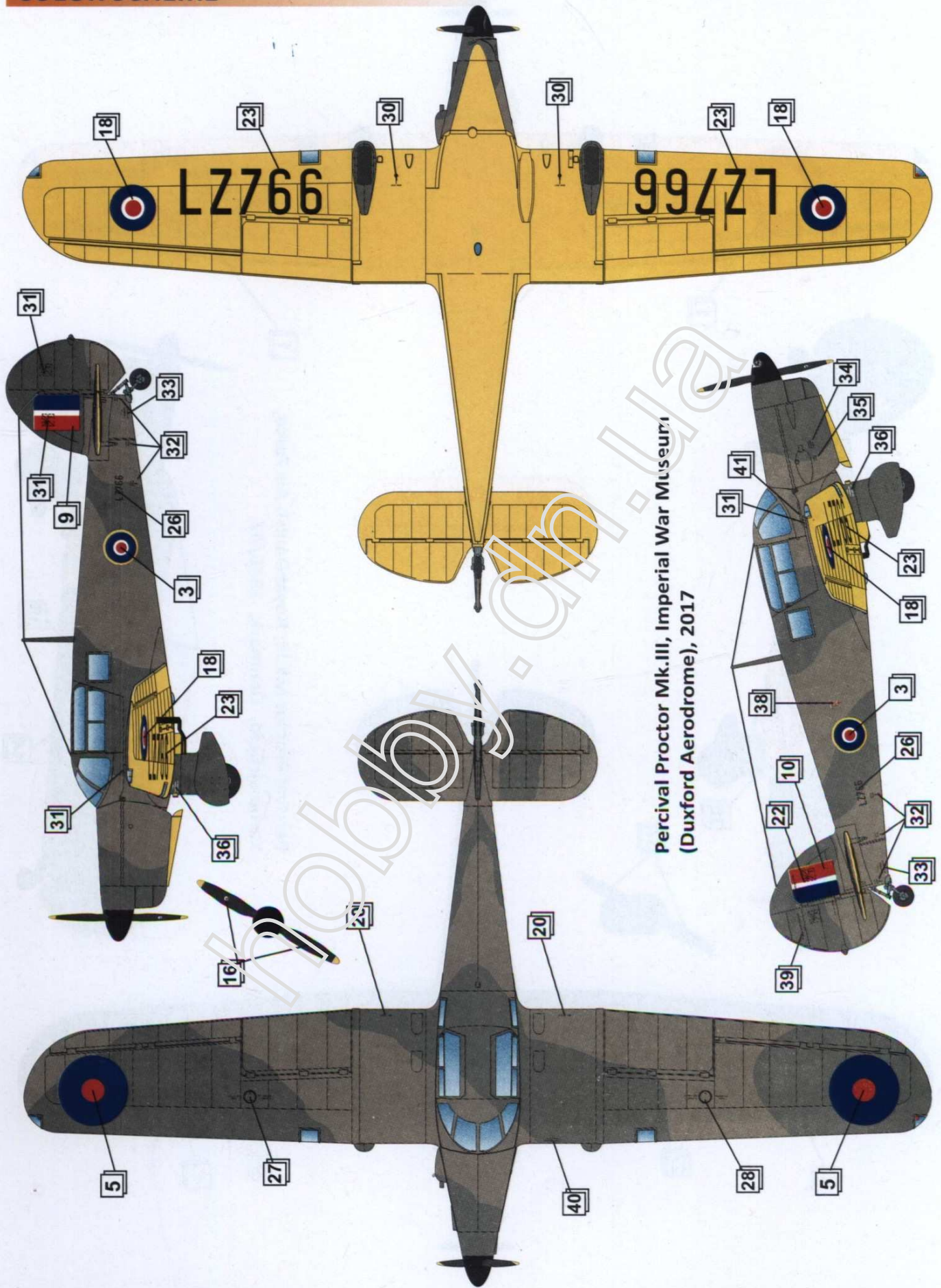

Percival Proctor Mk.III, Imperial War Museum
(Duxford Aerodrome), 2017

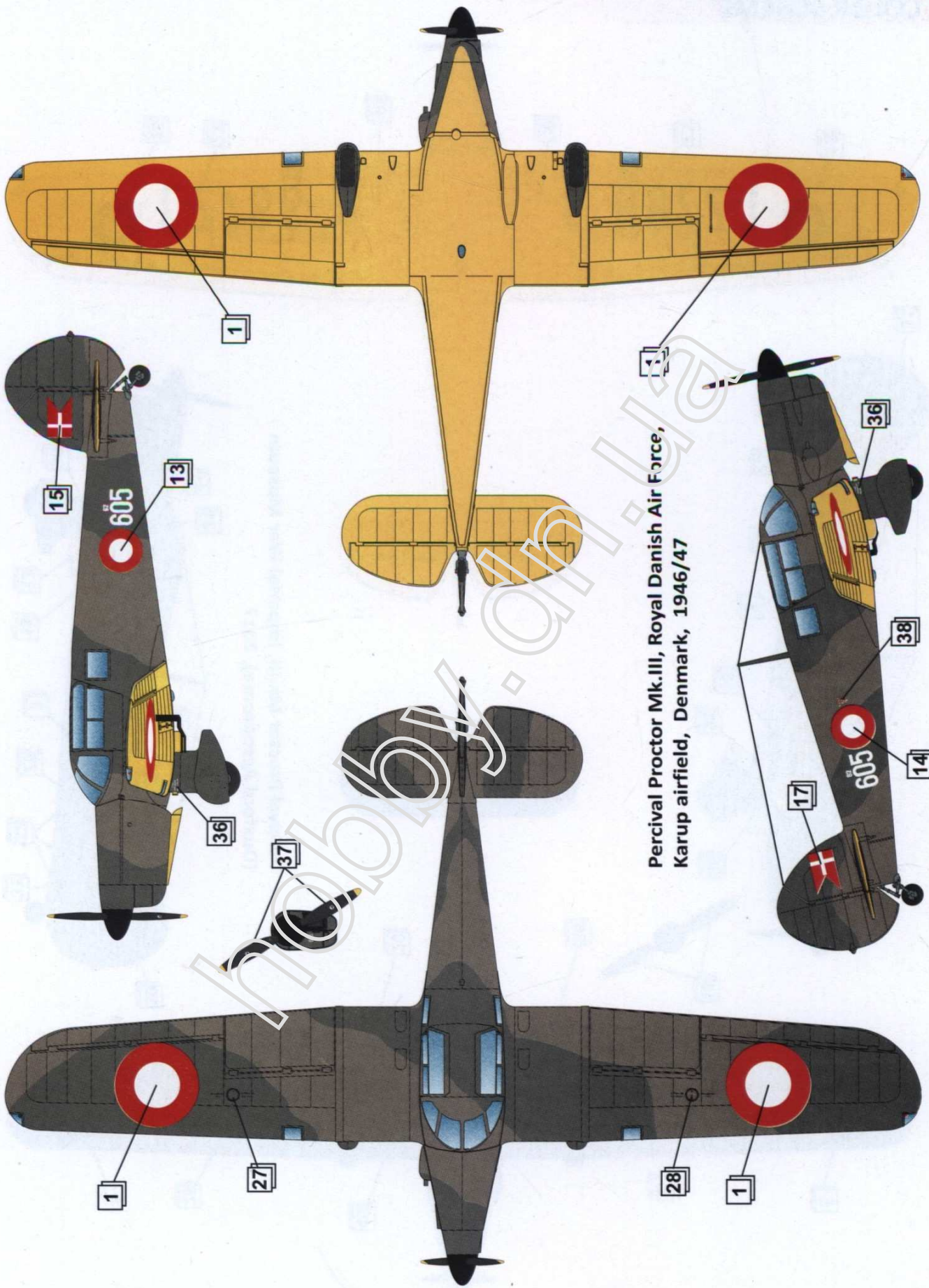

Percival Proctor Mk.III, Royal Danish Air Force,
 Karup airfield, Denmark, 1946/47

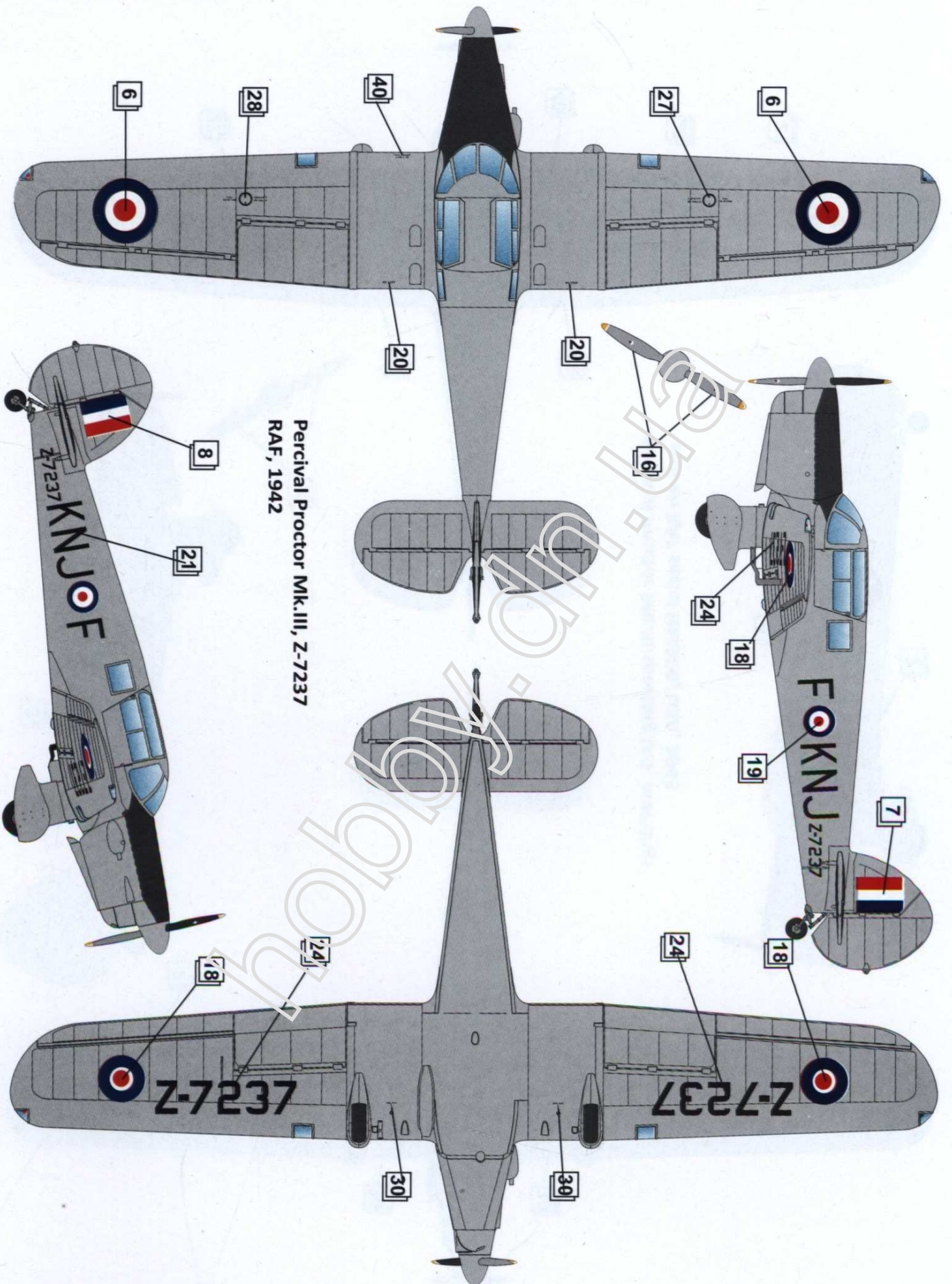

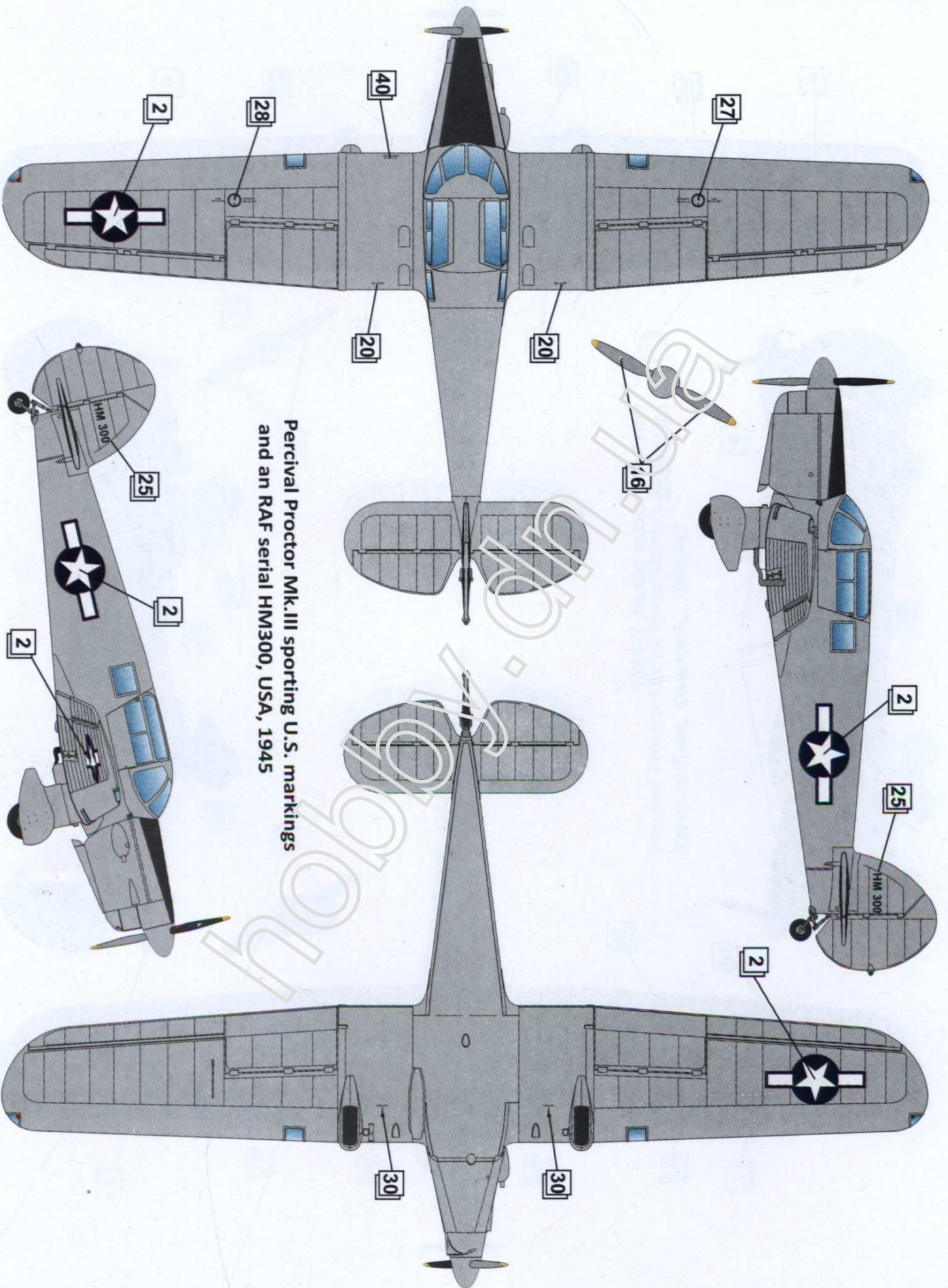

Percival Proctor Mk.III sporting U.S. markings
and an RAF serial HM300, USA, 1945

19

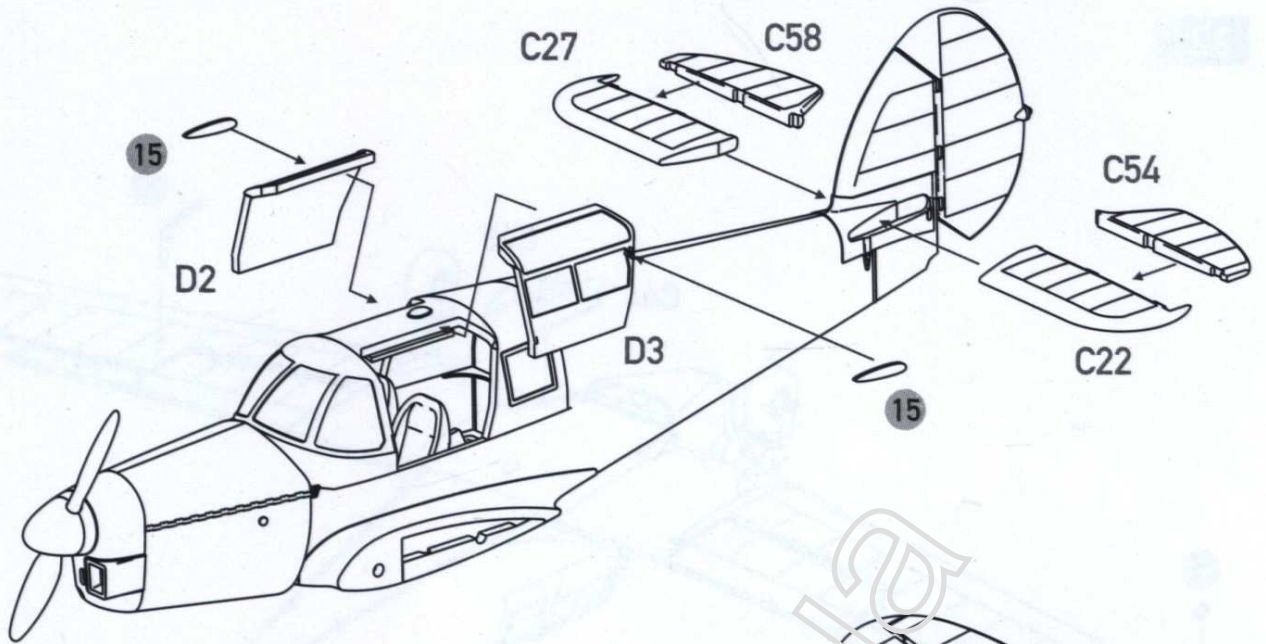

20

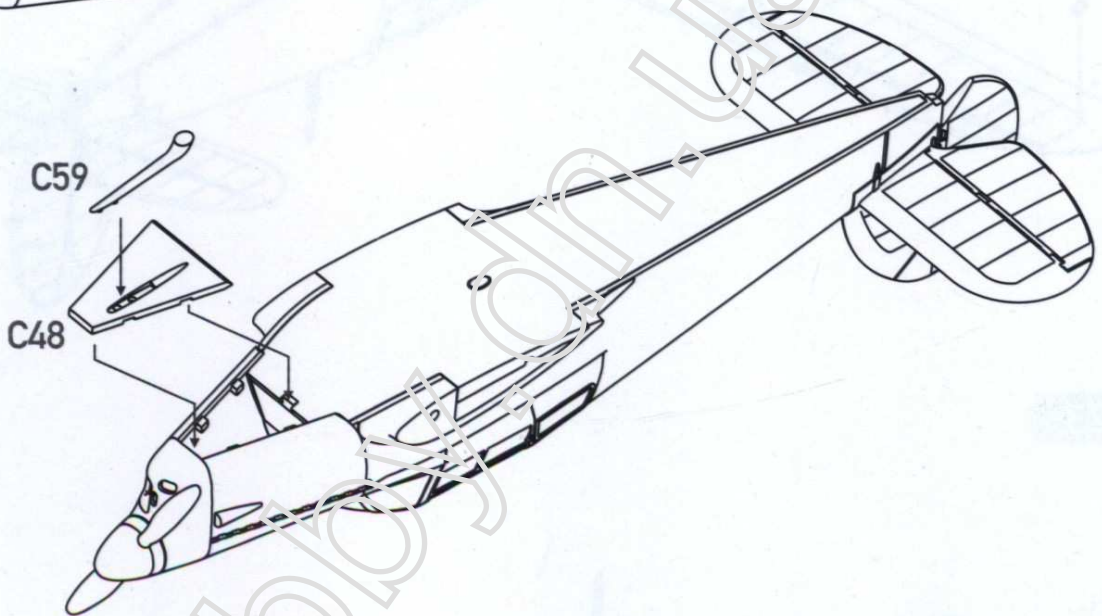

21

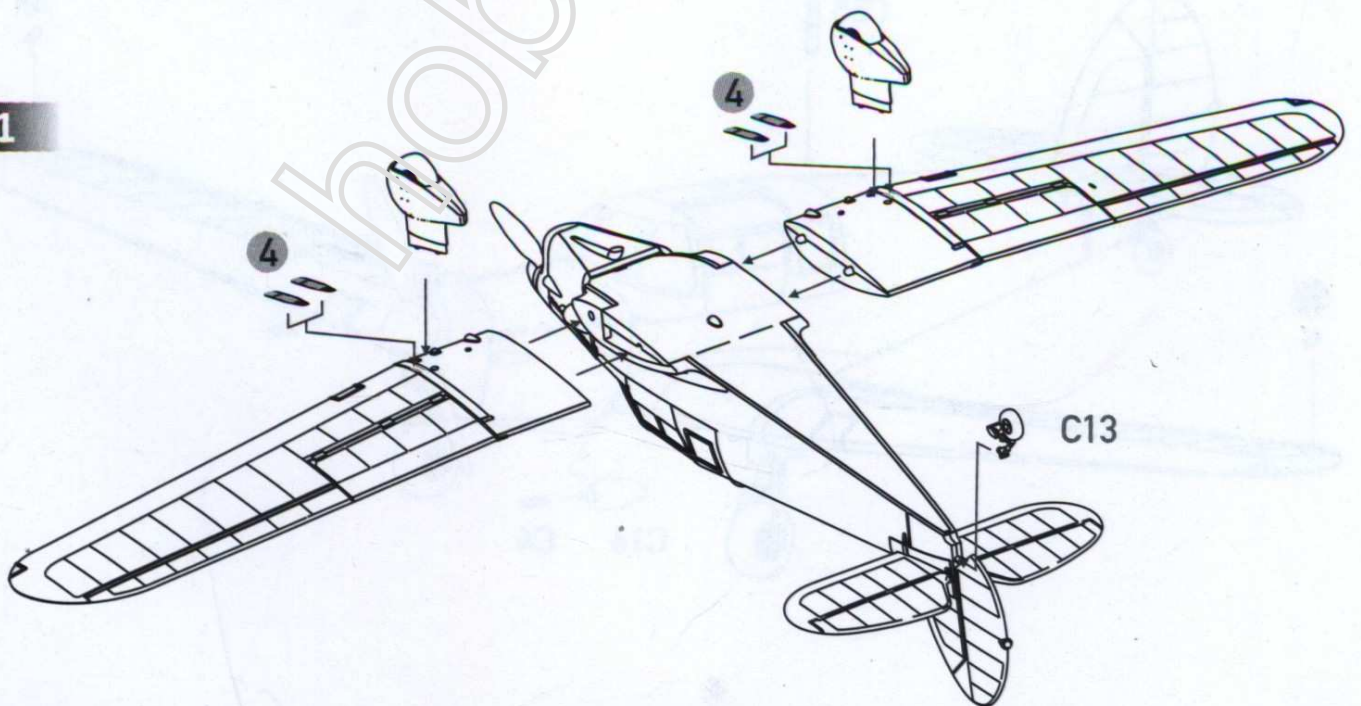

22

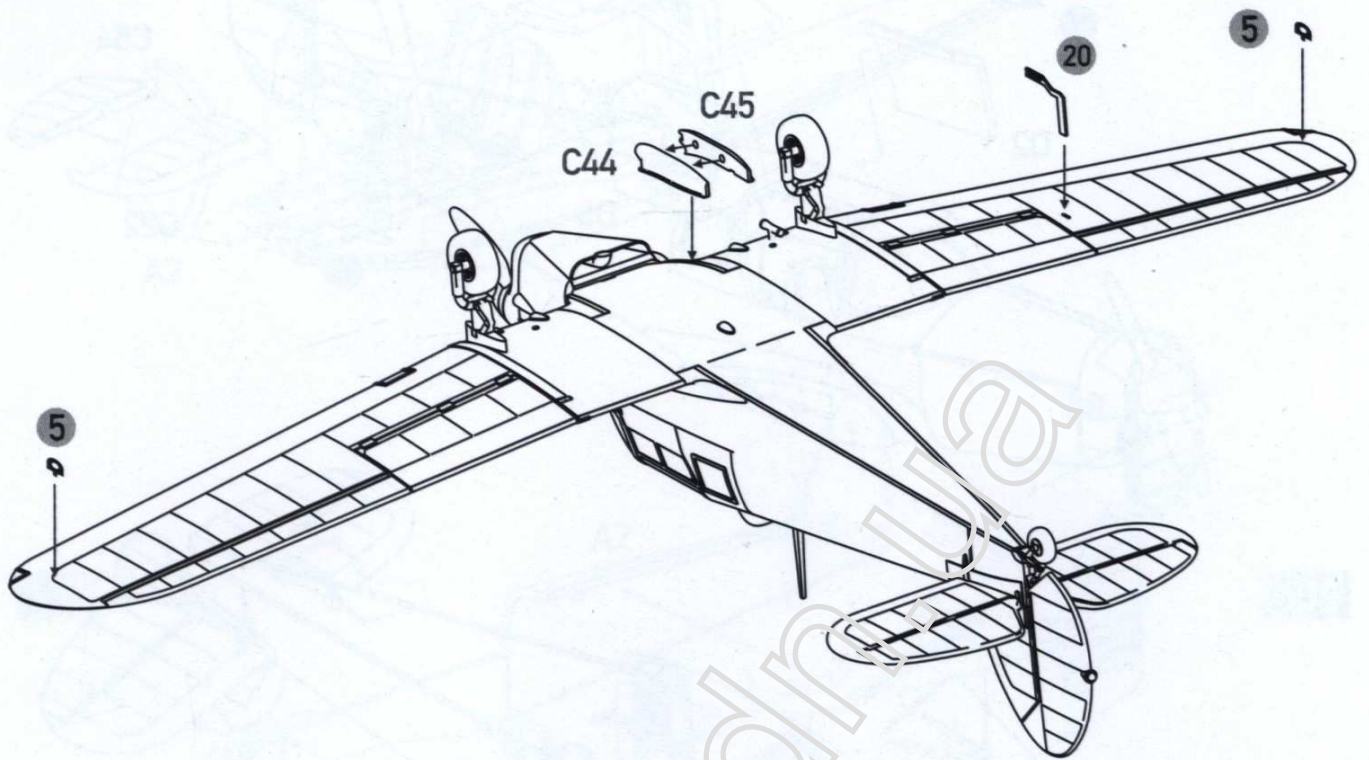

23

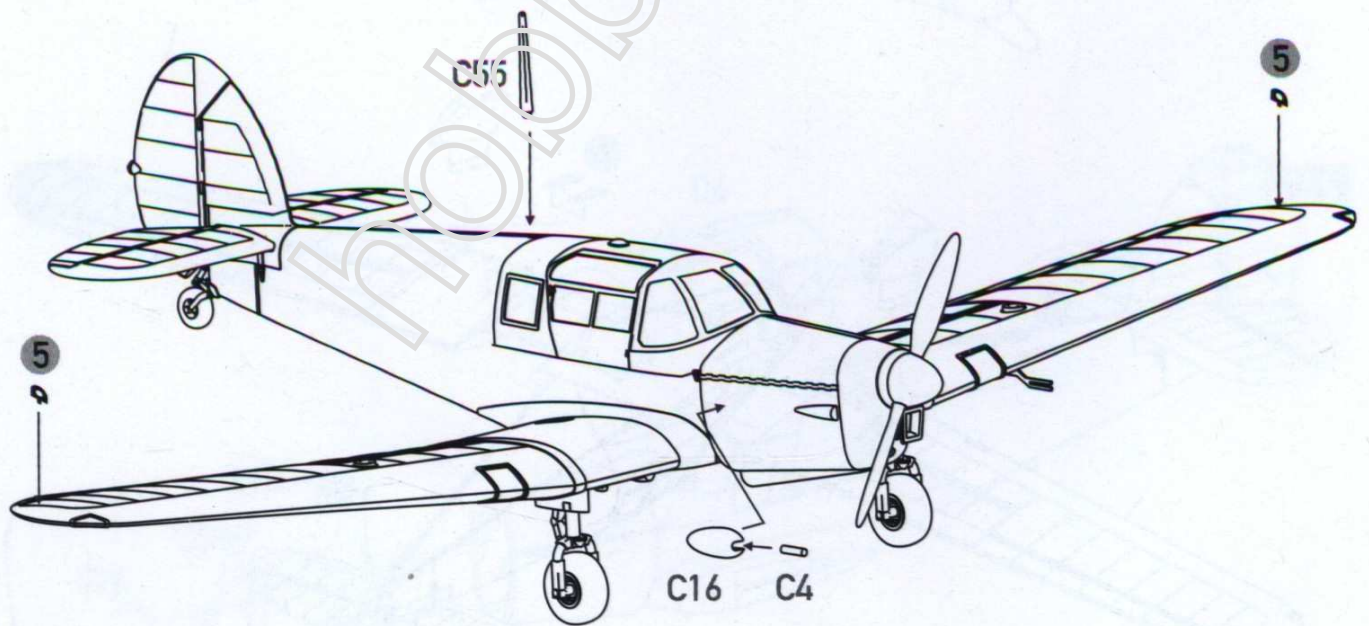

TECHNICAL STENCIL

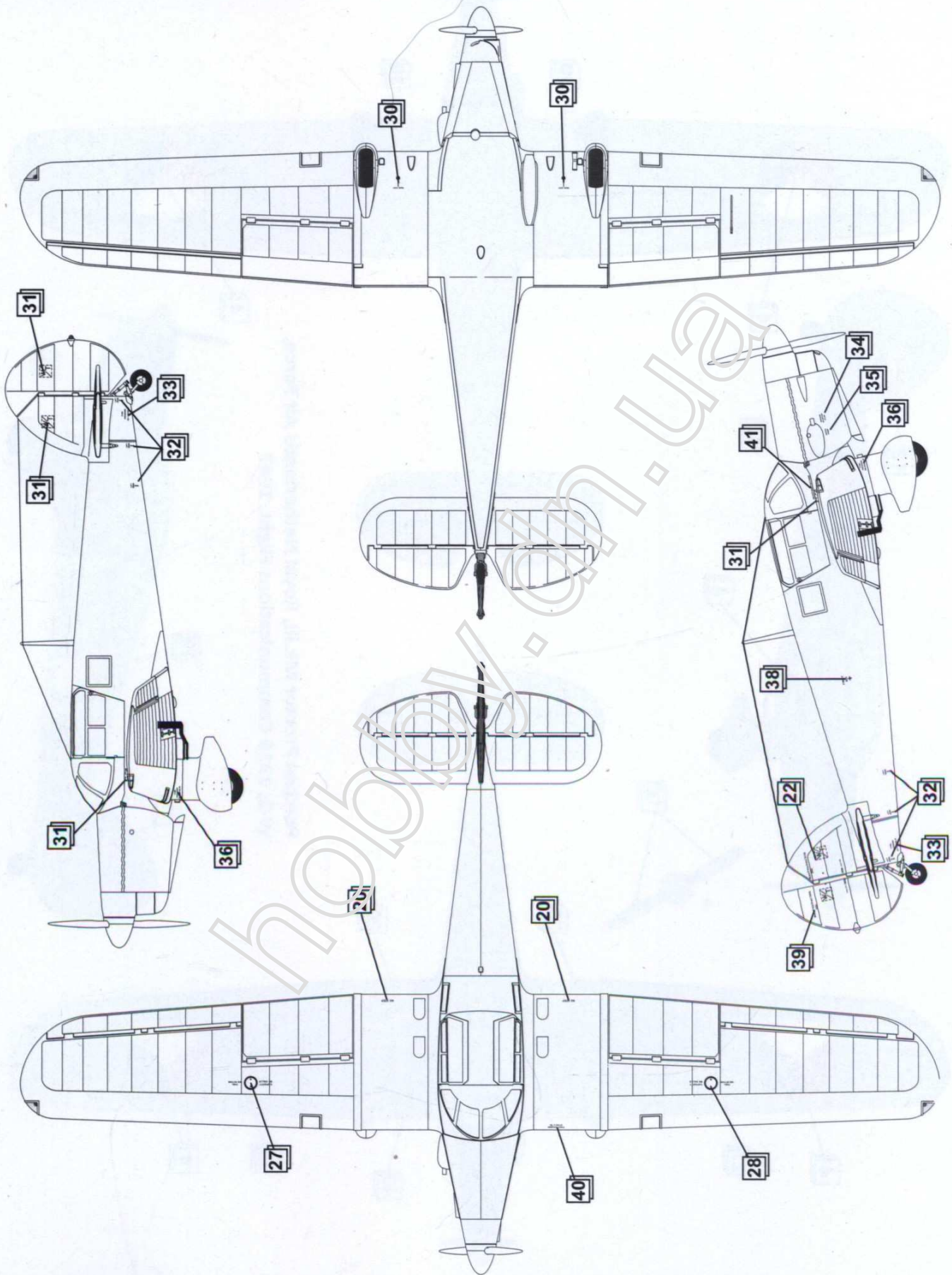

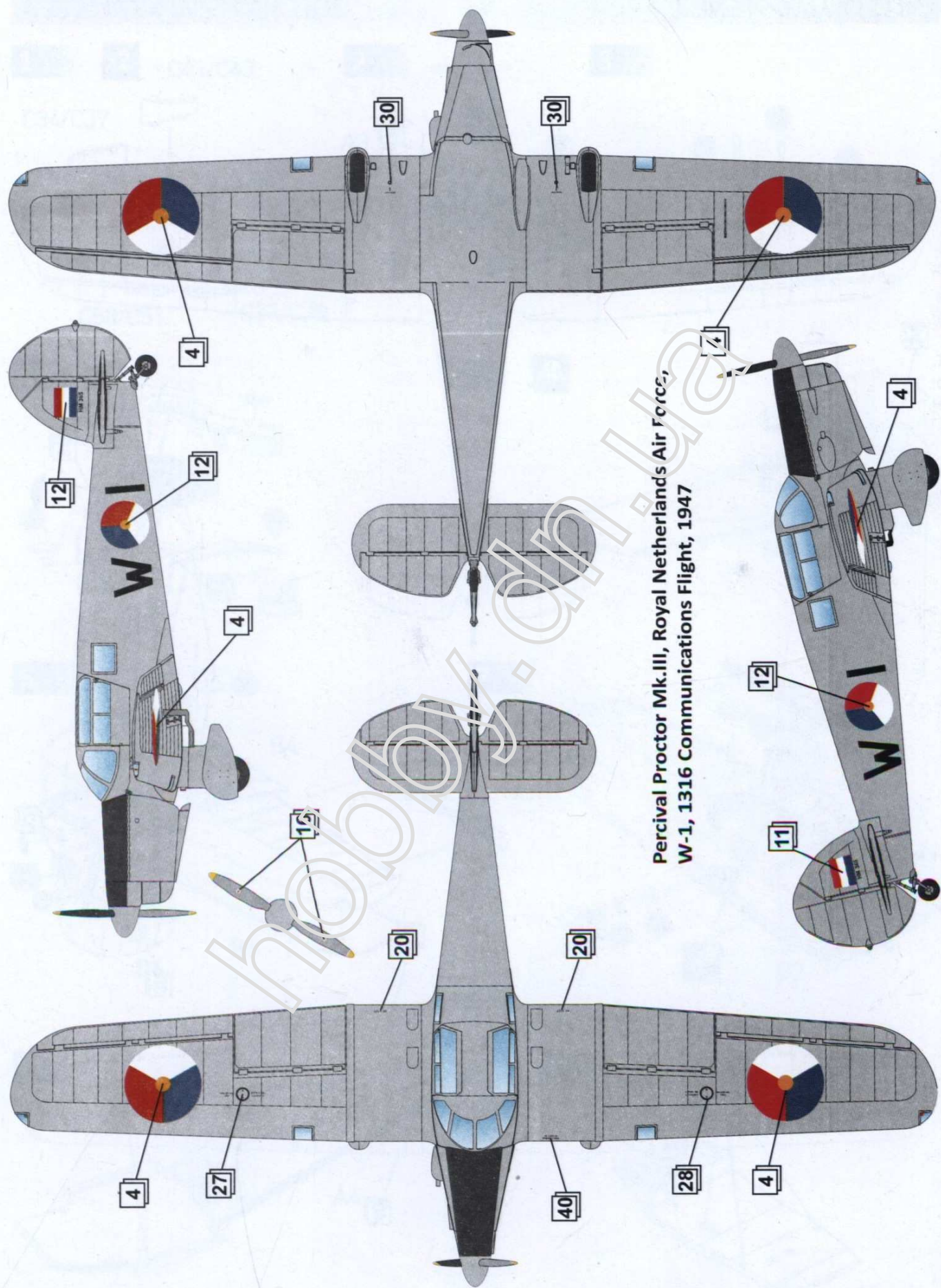

Percival Proctor Mk.III, Royal Netherlands Air Force,
W-1, 1316 Communications Flight, 1947



Percival Vega Gull

in military service

1/72 SCALE MODEL CONSTRUCTION KIT

Ready to assemble scale models kit.

Contains part for one model.

Model length: 112 mm

Wingspan: 168 mm

Plastic parts: 57

Photoetched parts: 47

Vega Gulls have been registered in the following countries: Argentina, Australia, Belgium, Canada, France, Germany, India, Iraq, Japan, Kenya, Netherlands, New Zealand, Sweden, Switzerland, United Kingdom

The Percival Vega Gull model was created on the basis of the original drawings, which were given to the company of Dora Wings by **Mr. John Adams (Aeroclub company)**. He also advised the designers of the company, and provided every help. The team of Dora Wings expresses great gratitude to John Adams for help and advice. You're the man John!

PARTS OF THE MODEL

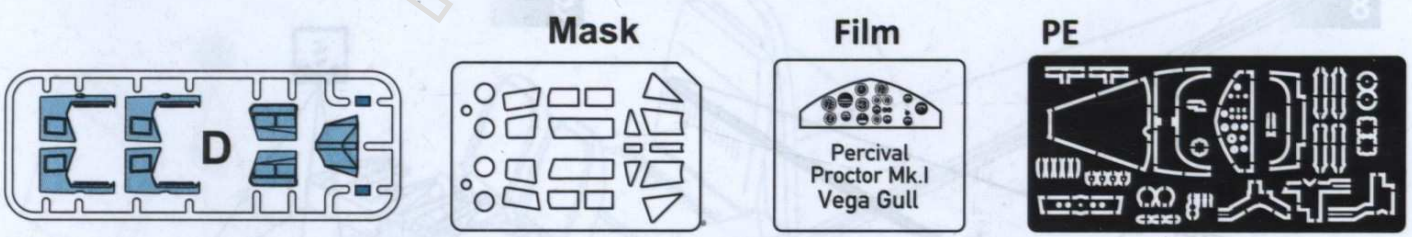
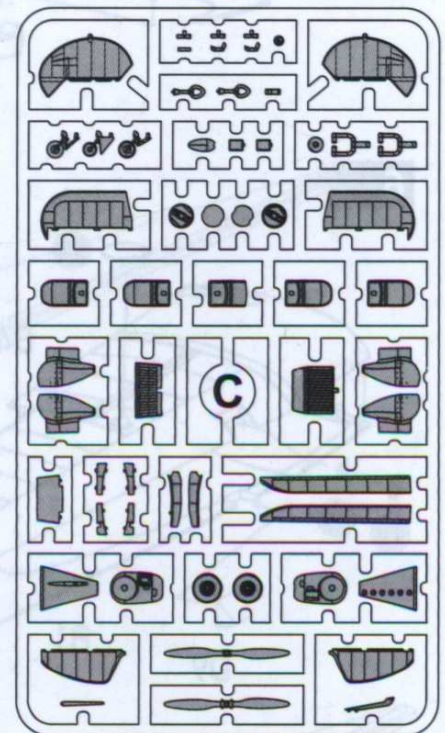
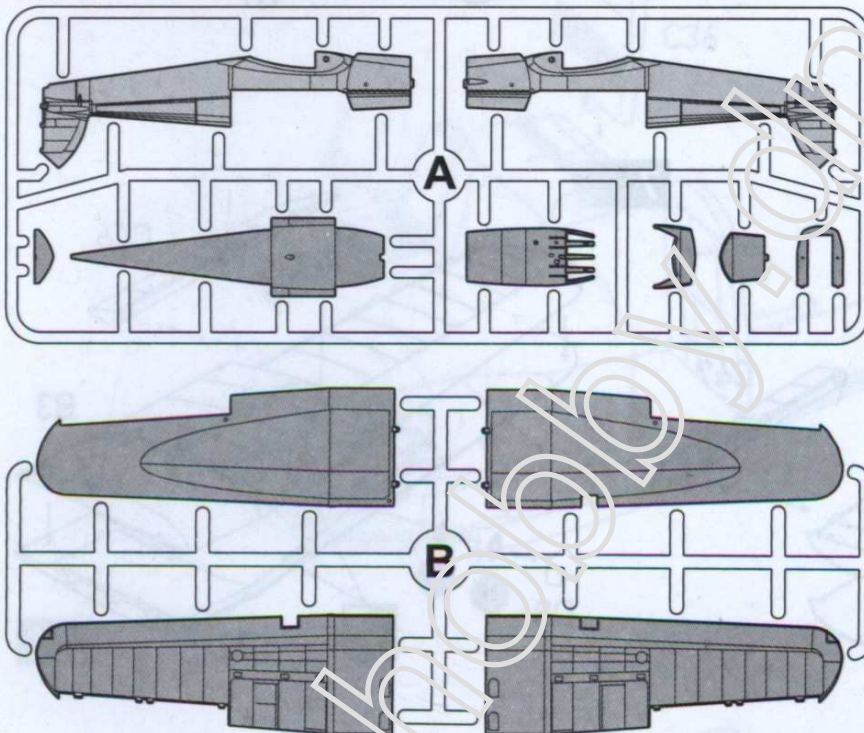

USED SYMBOLS



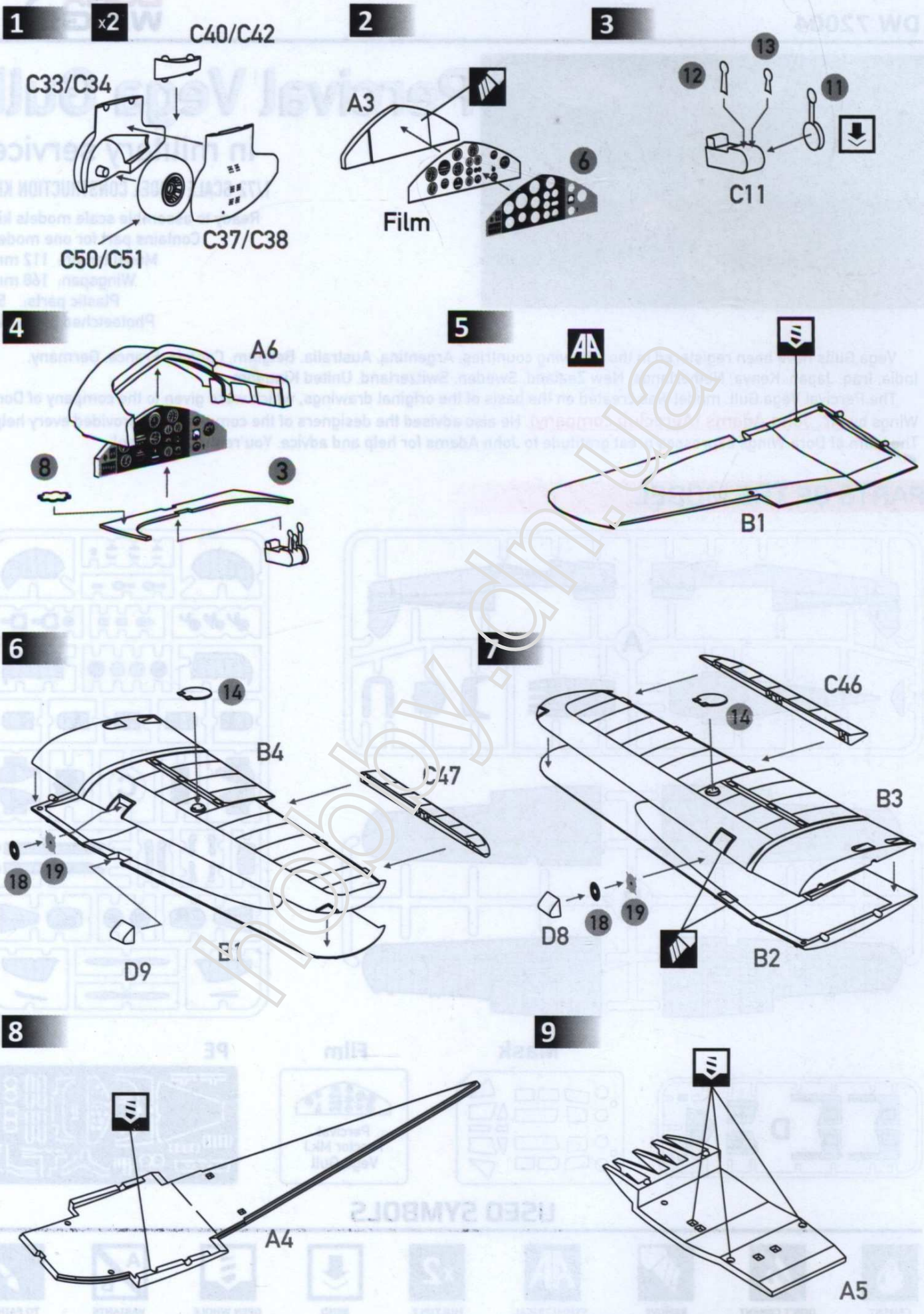

10 x2



11

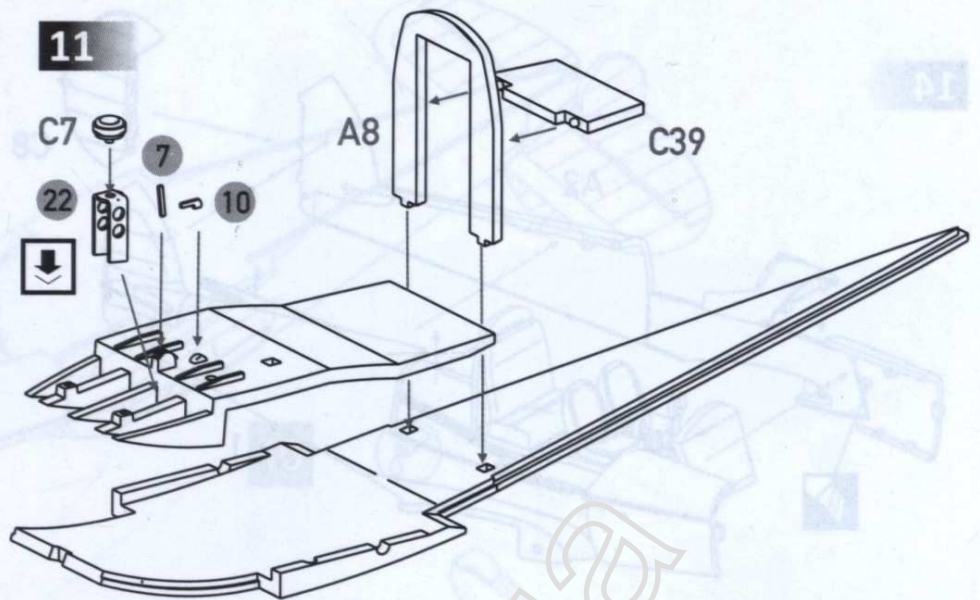

12

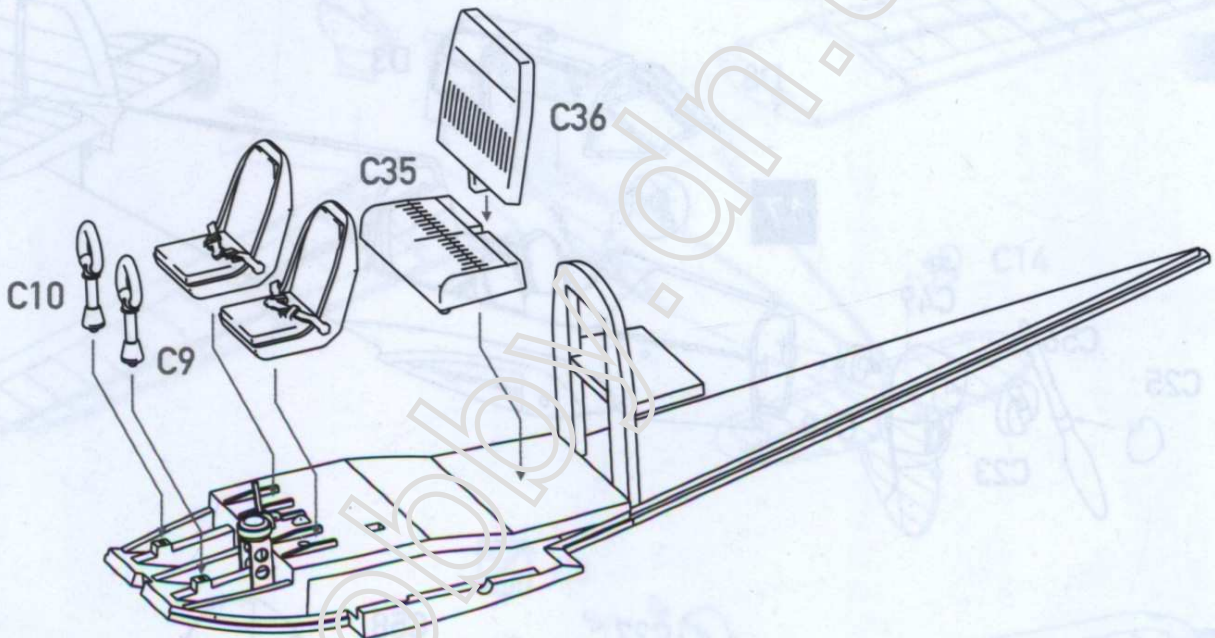

13

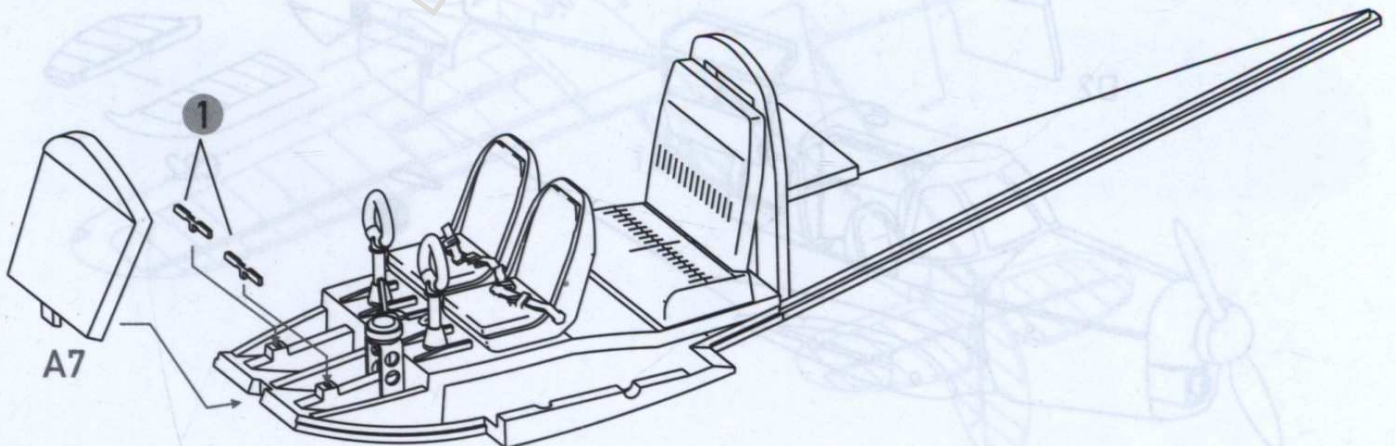

14

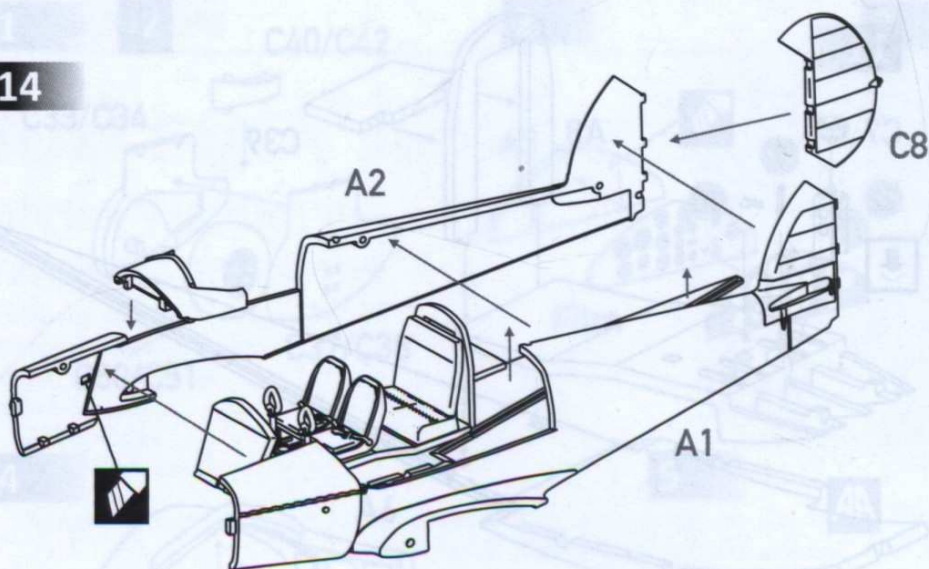

15

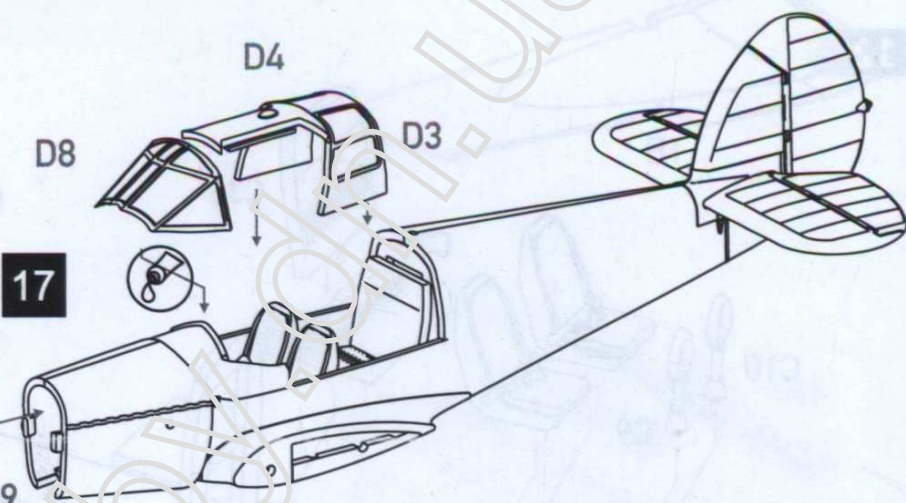

17

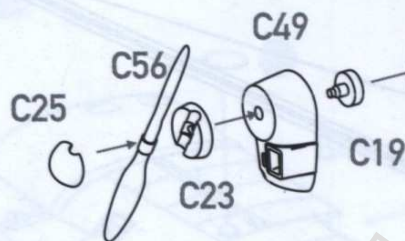

16

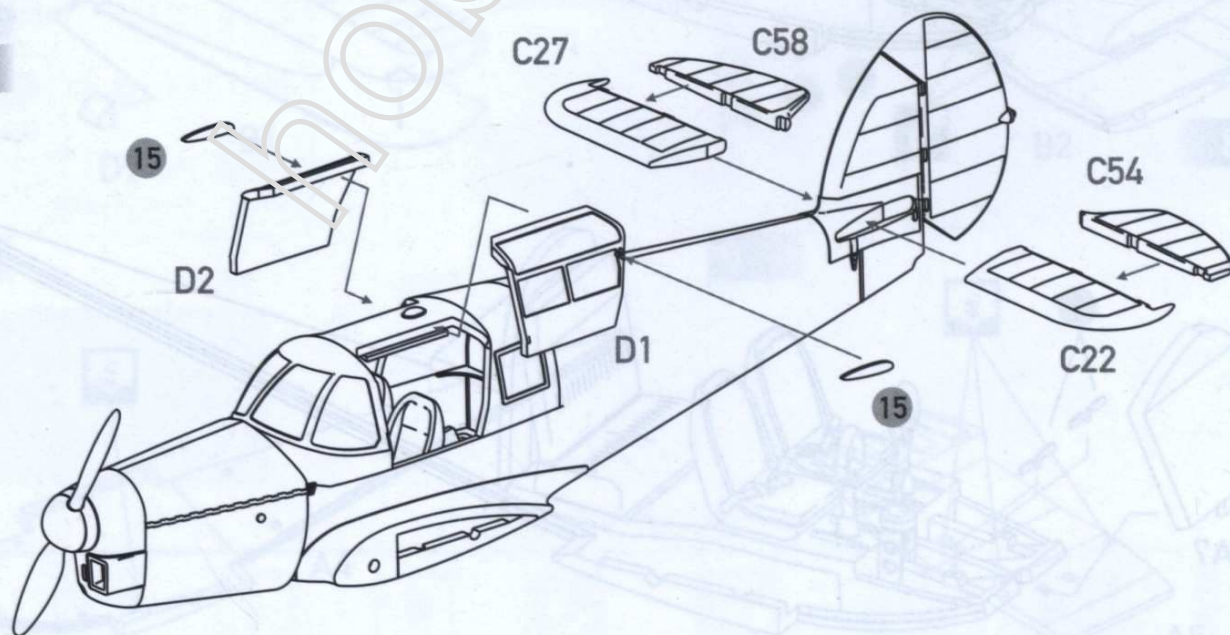

17

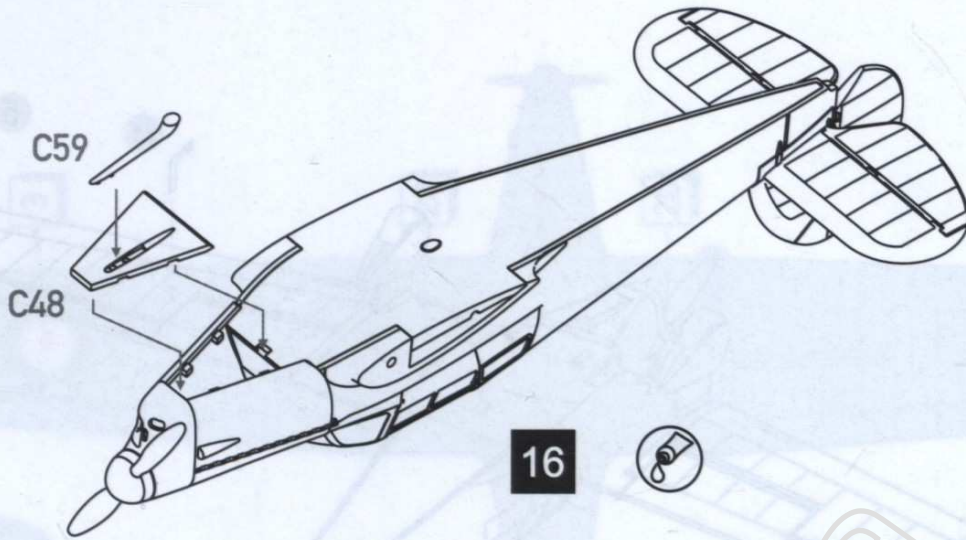

16



18

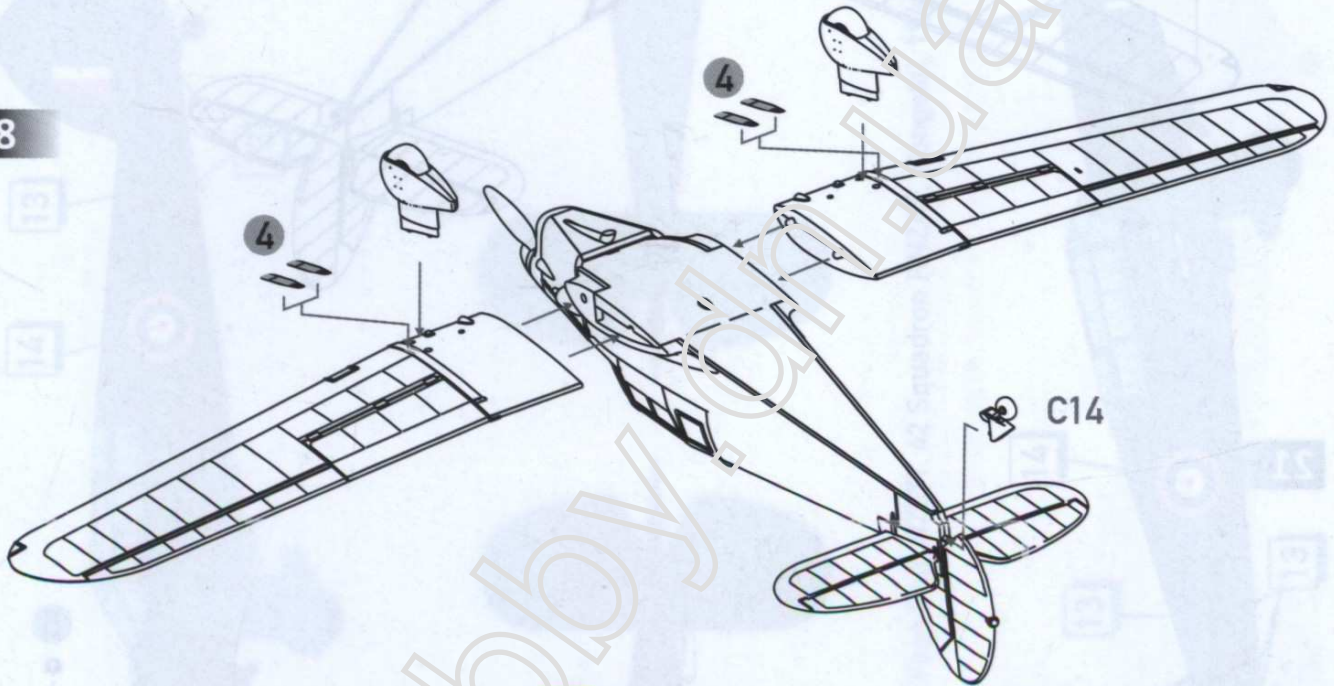

19

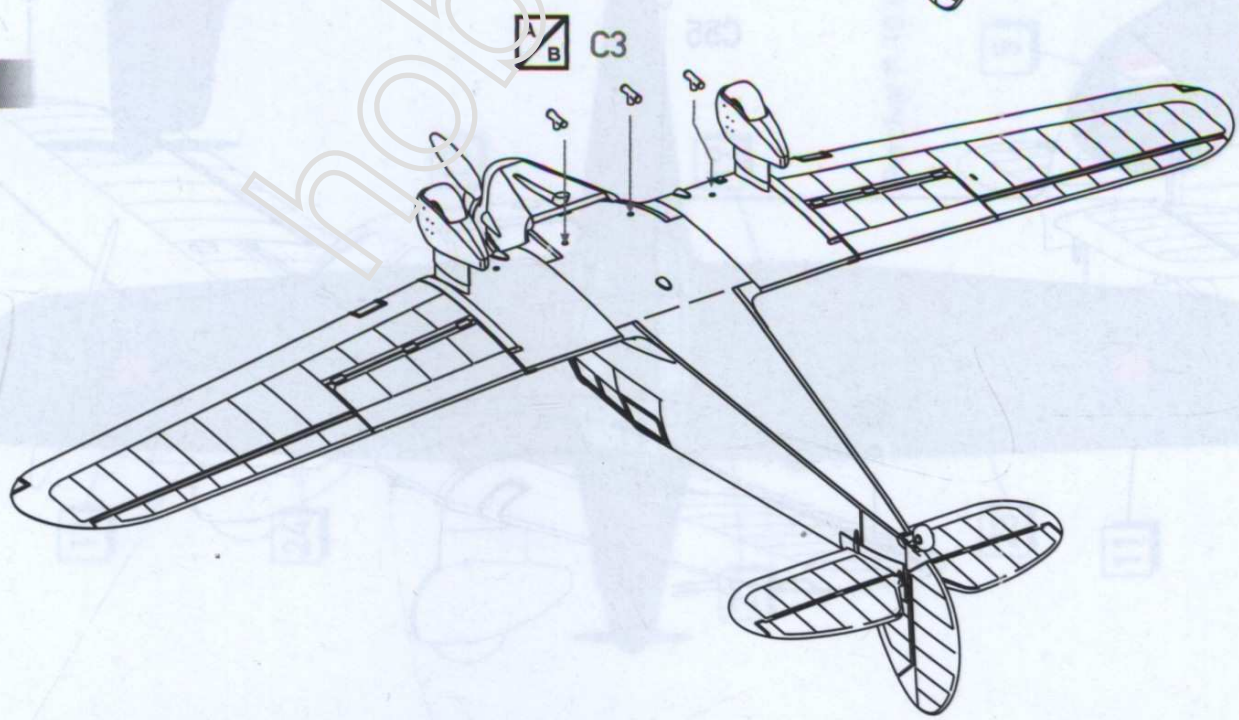

20

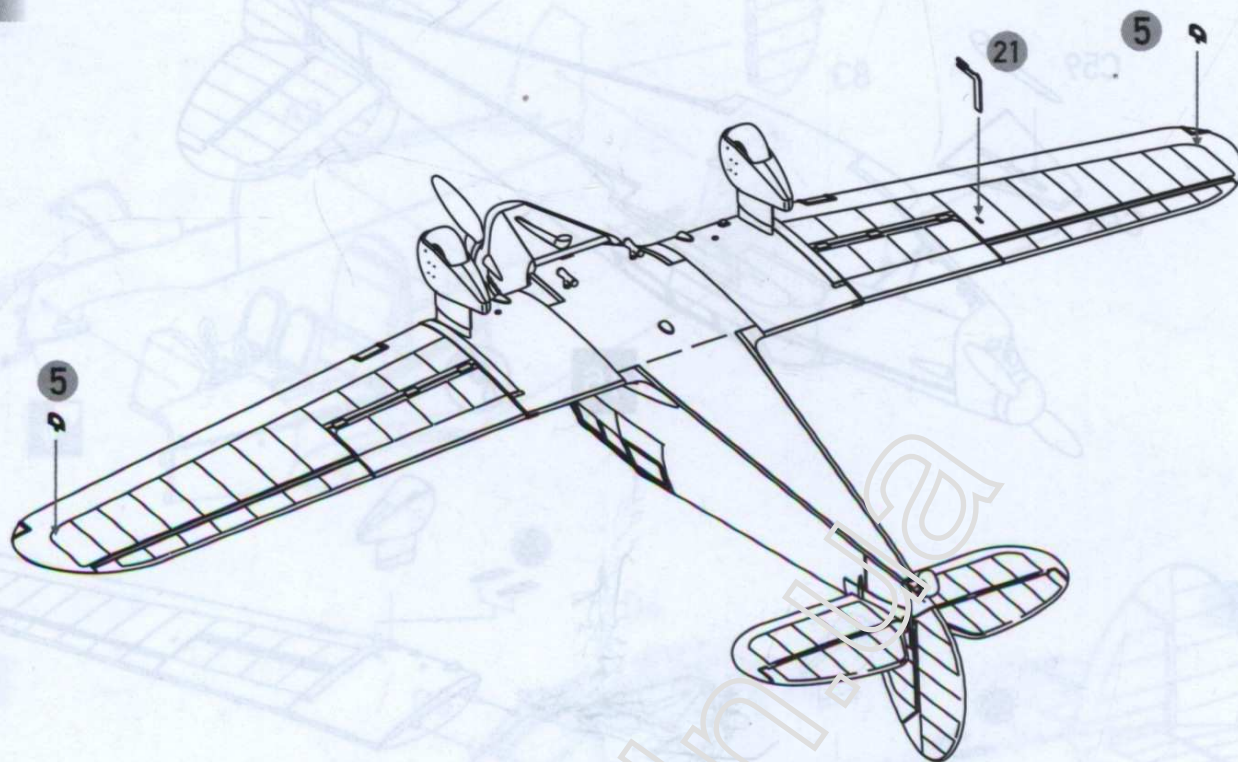

21

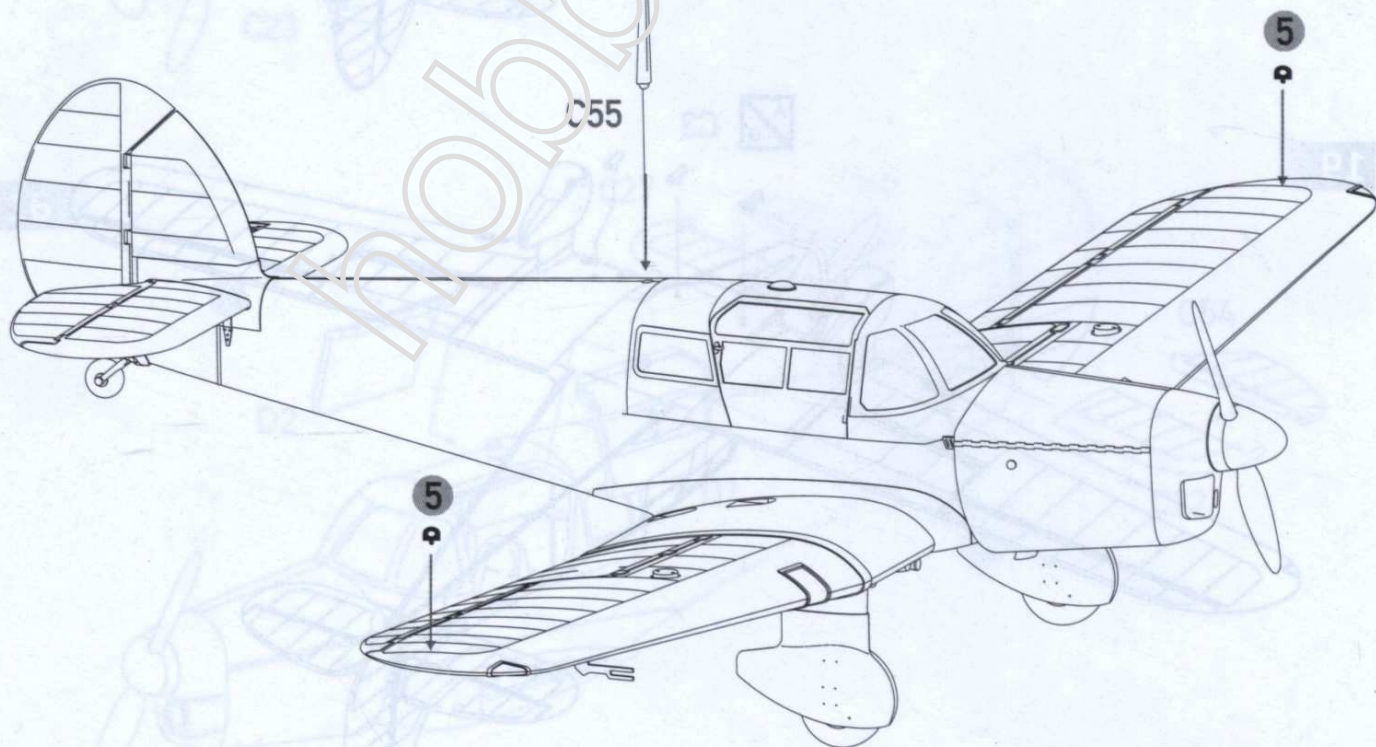

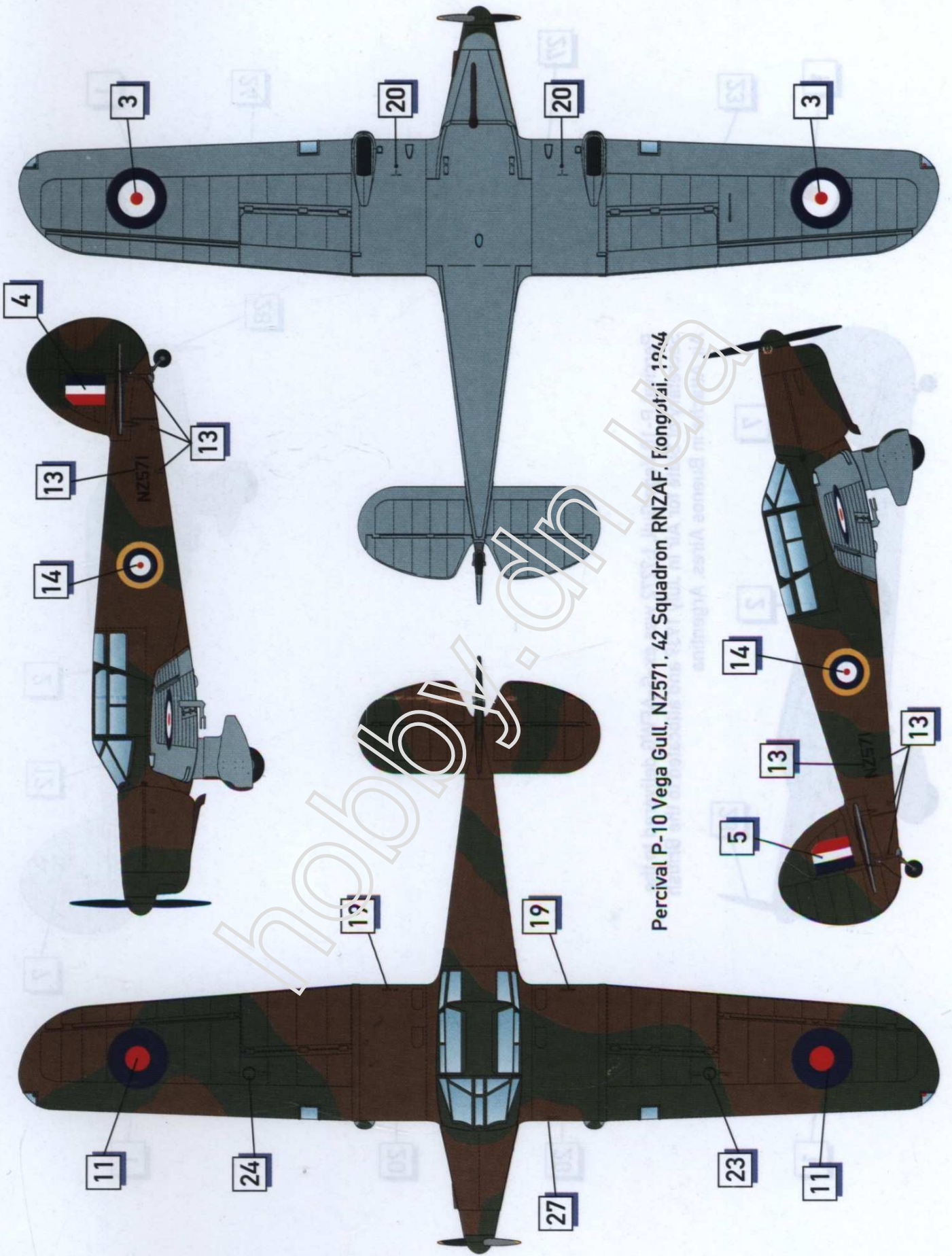

Percival P-10 Vega Gull, NZ571, 42 Squadron RNZAF, Fongofai, 1944

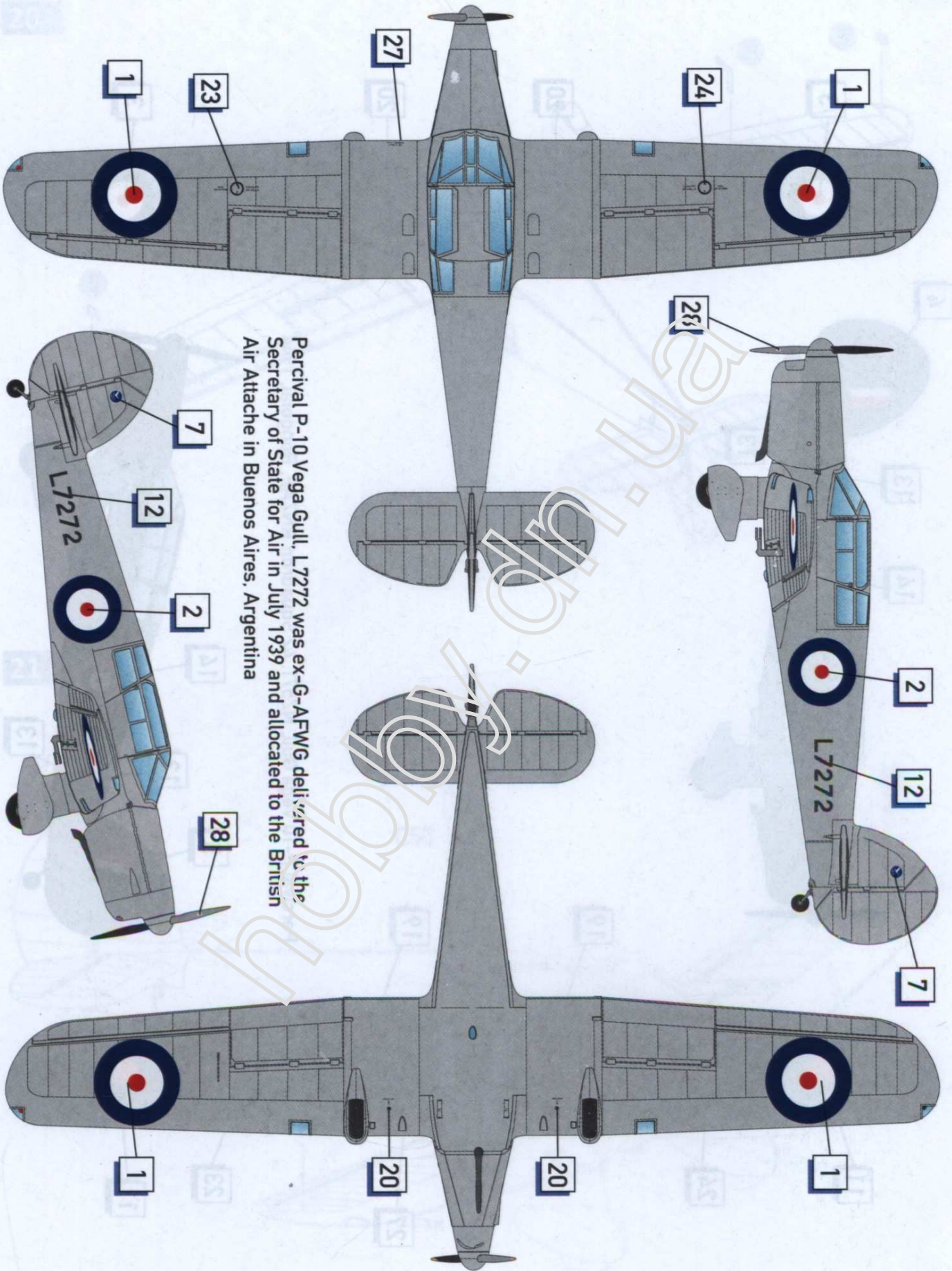

Percival P-10 Vega Gull, L7272 was ex-G-AFWG delivered to the Secretary of State for Air in July 1939 and allocated to the British Air Attache in Buenos Aires, Argentina

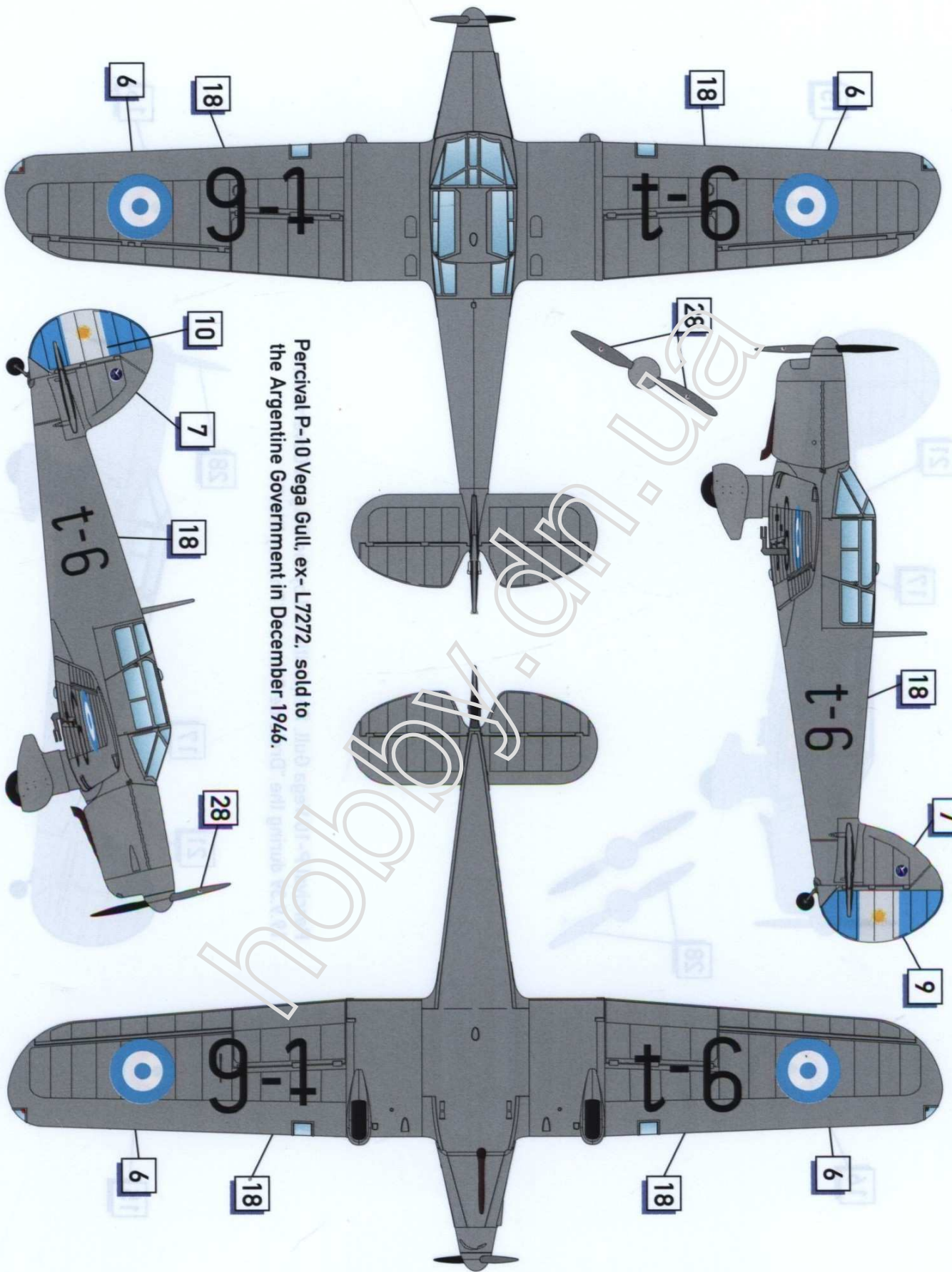

Percival P-10 Vega Gull, ex- L7272, sold to the Argentine Government in December 1946.

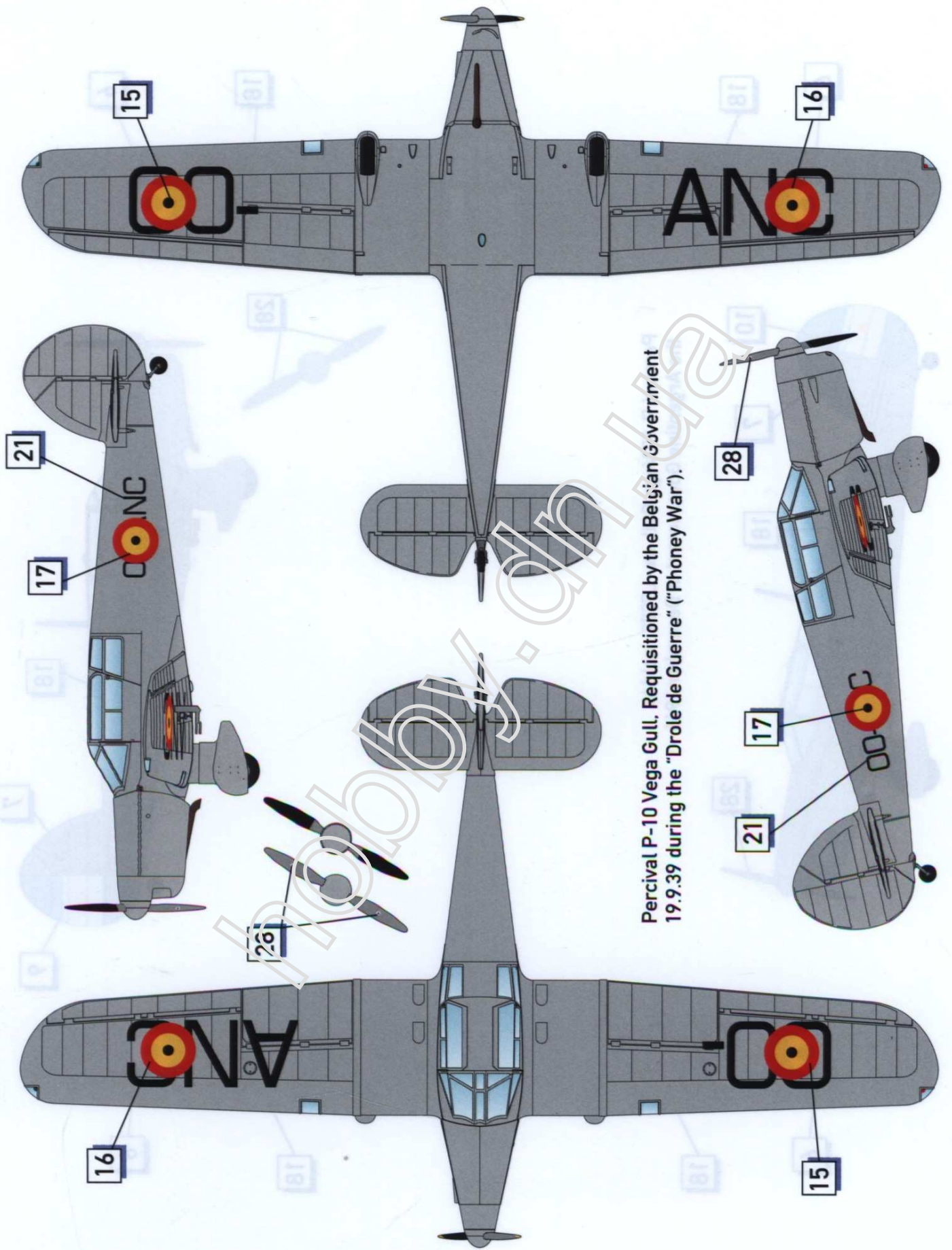

Percival P-10 Vega Gull, Requisitioned by the Belgian Government 19.9.39 during the "Drole de Guerre" ("Phoney War").