

PLASTIC PARTS

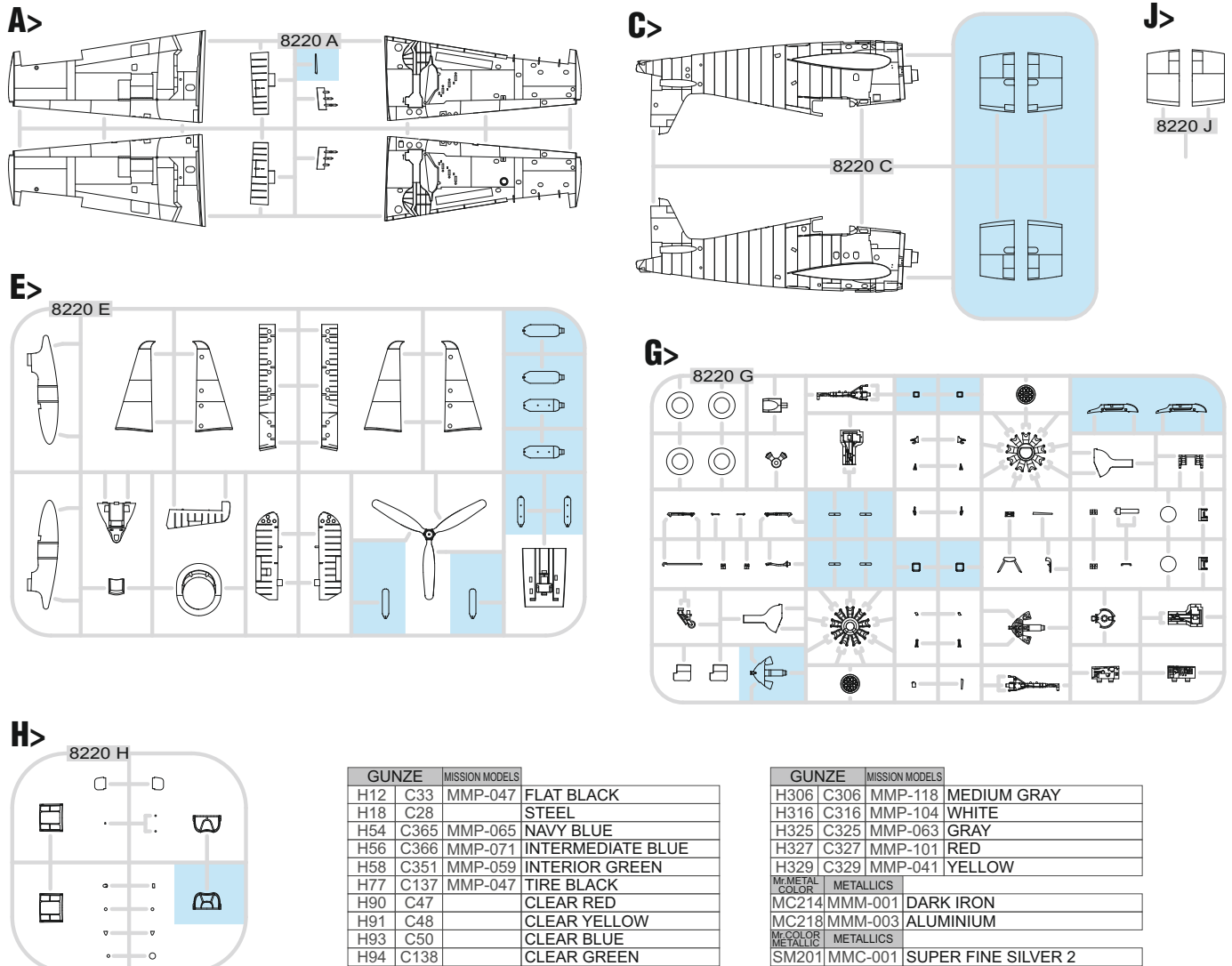

ATTENTION



UPOZORNĚNÍ



ACHTUNG



ATTENTION

(GB)

Carefully read instruction sheet before assembling. When you use glue or paint, do not use near open flame and use in well ventilated room. Keep out of reach of small children. Children must not be allowed to suck any part, or pull vinyl bag over the head.

(CZ)

Před započatím stavby si pečlivě prostudujte stavební návod. Při používání barev a lepidel pracujte v dobře větrané místnosti. Lepidla ani barvy nepoužívejte v blízkosti otevřeného ohně. Model není určen malým dětem, mohlo by dojít k požití drobných dílů.

(D)

Vor dem Zusammenbau die Bauanleitung gut durchlesen. Kleber und Farben nicht in der Nähe von offenem Feuer verwenden und für eine ausreichende Belüftung sorgen. Den Bausatz von kleinen Kindern fernhalten. Vermeiden Sie, dass Kinder Bauteile in den Mund nehmen oder sich Plastiktüten über den Kopf ziehen.

(F)

Lire soigneusement la fiche d'instructions avant d'assembler. Ne pas utiliser de colle ou de peinture à proximité d'une flamme nue, et aérer la pièce de temps en temps. Garder hors de portée des enfants en bas âge. Ne pas laisser les enfants mettre en bouche ou sucer les pièces, ou passer un sachet vinyl sur la tête.

INSTRUCTION SIGNS



INSTR. SYMBOLY



INSTRUKTION SINNBILDEN



SYMBOLES

OPTIONAL
VOLBABEND
OHNOUTSAND
BROUSITOPEN HOLE
VYVRTAT OTVORSYMETRICAL ASSEMBLY
SYMETRICKÁ MONTÁŽREMOVE
ODŘÍZNOUTREVERSE SIDE
OTOČITAPPLY EDUARD MASK
AND PAINT
POUŽIT EDUARD MASK
NABARVIT

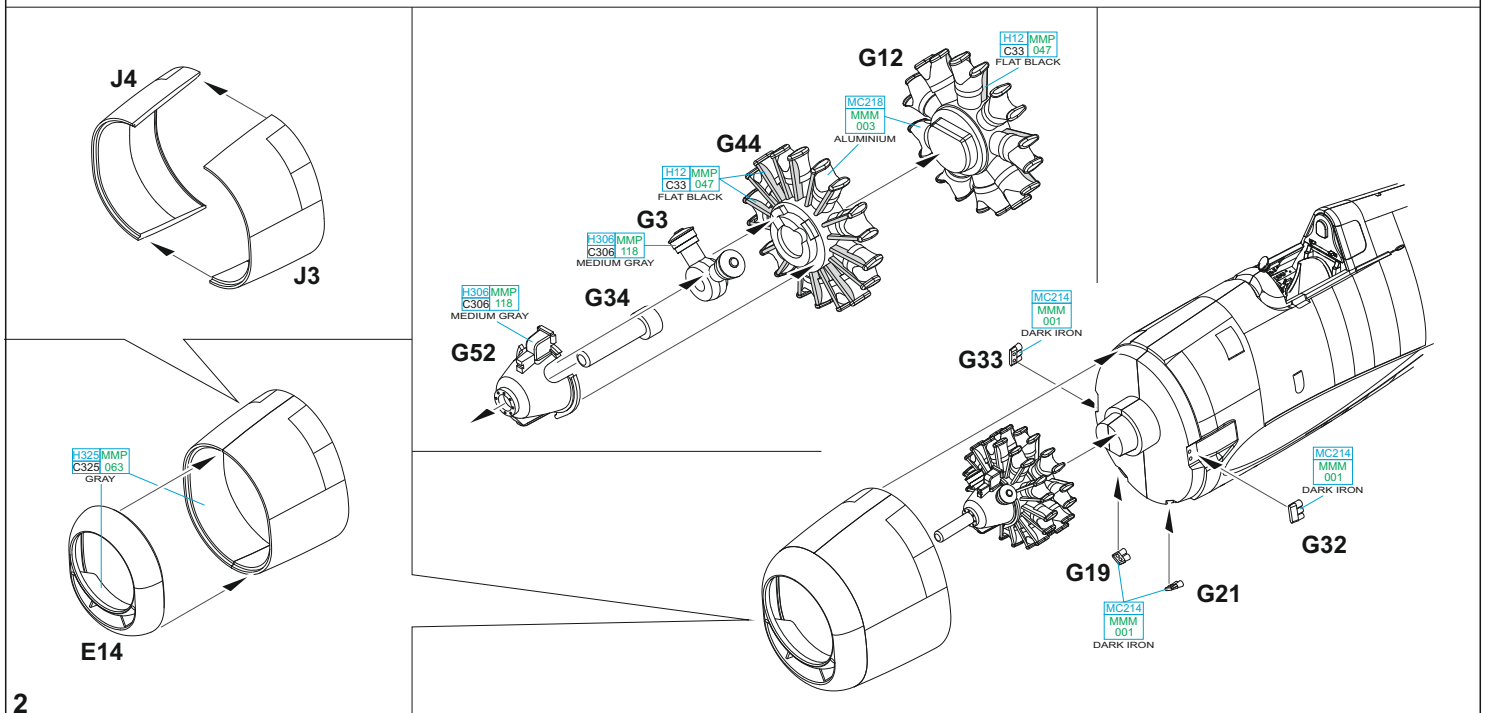
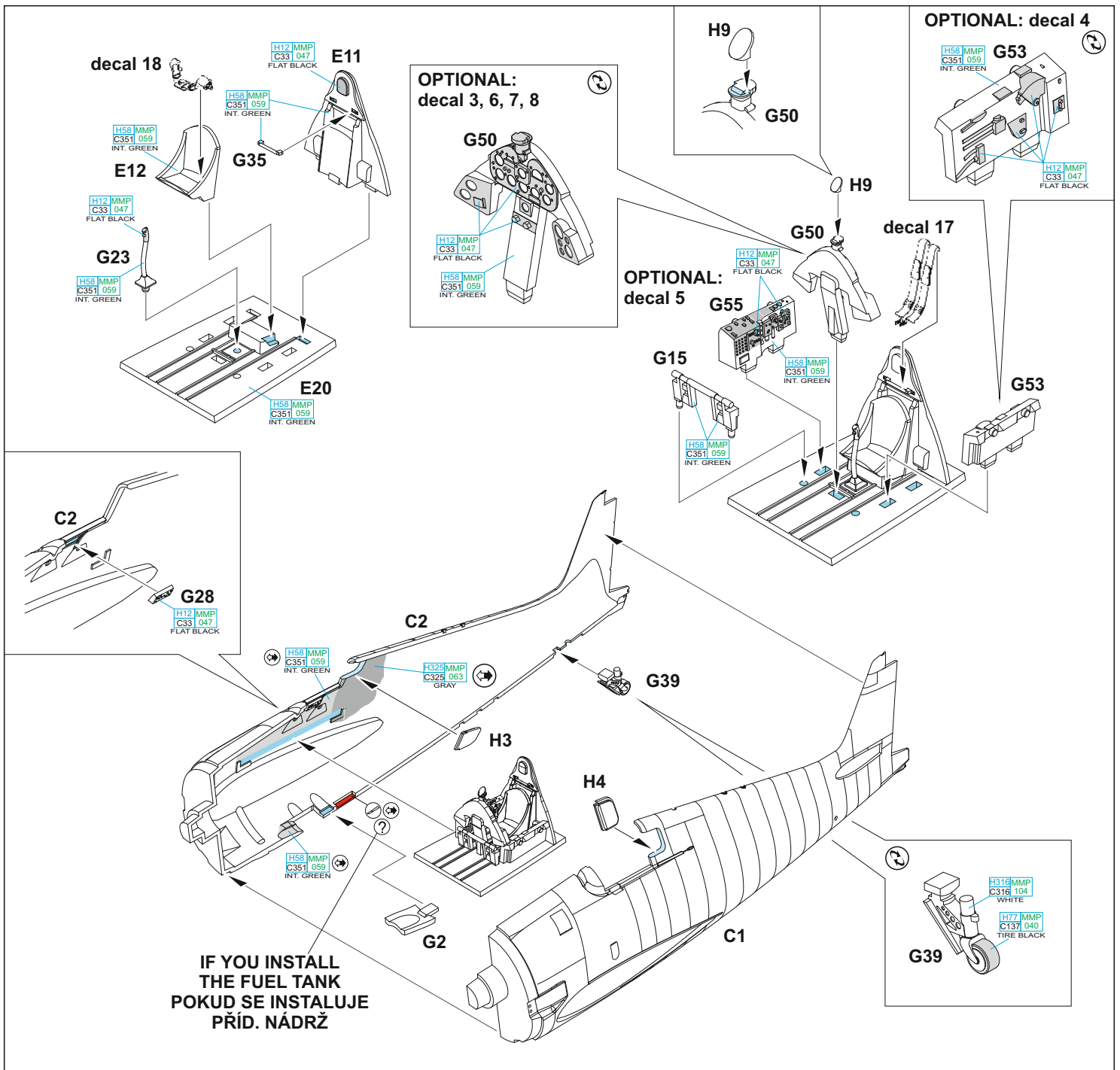

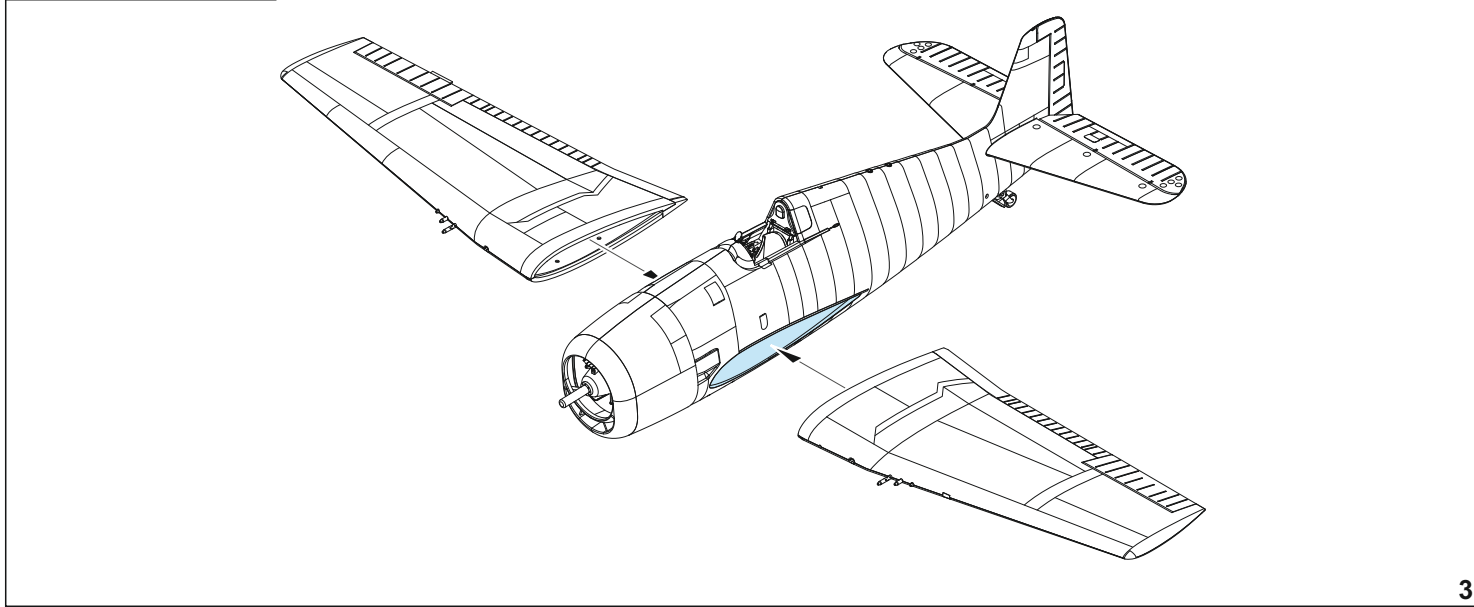
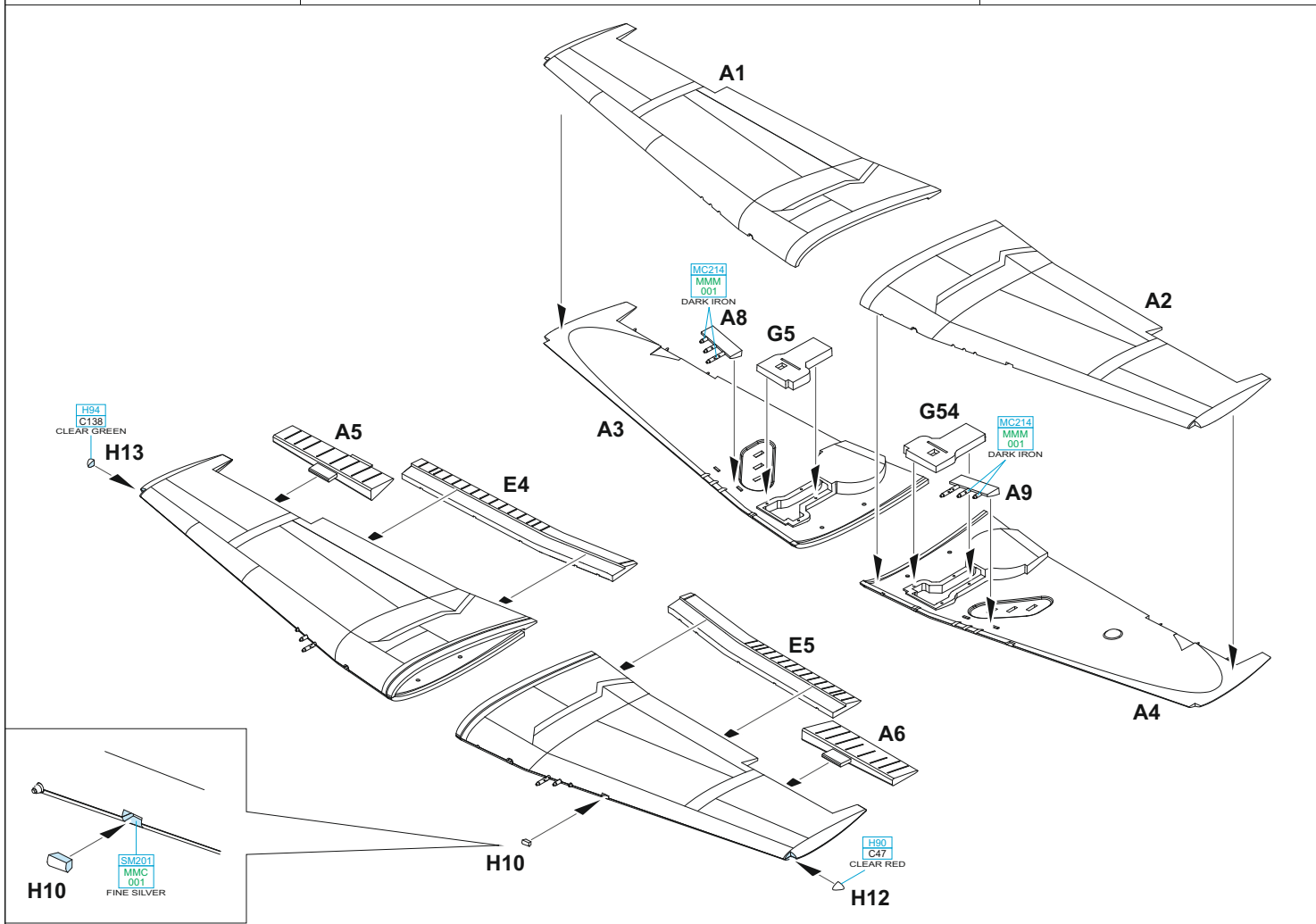
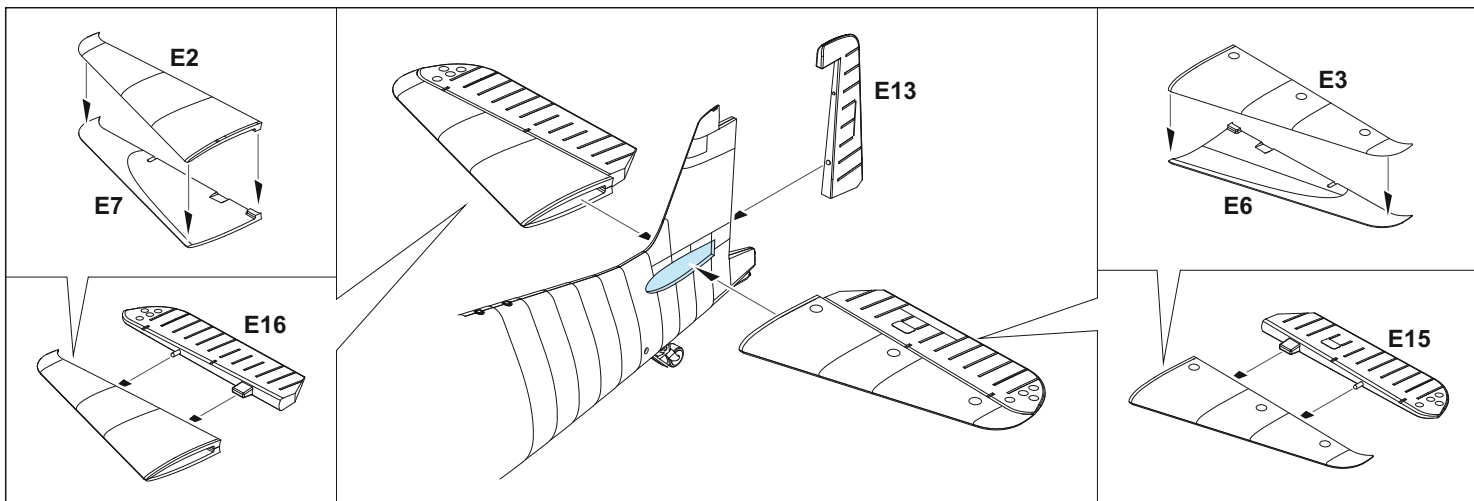

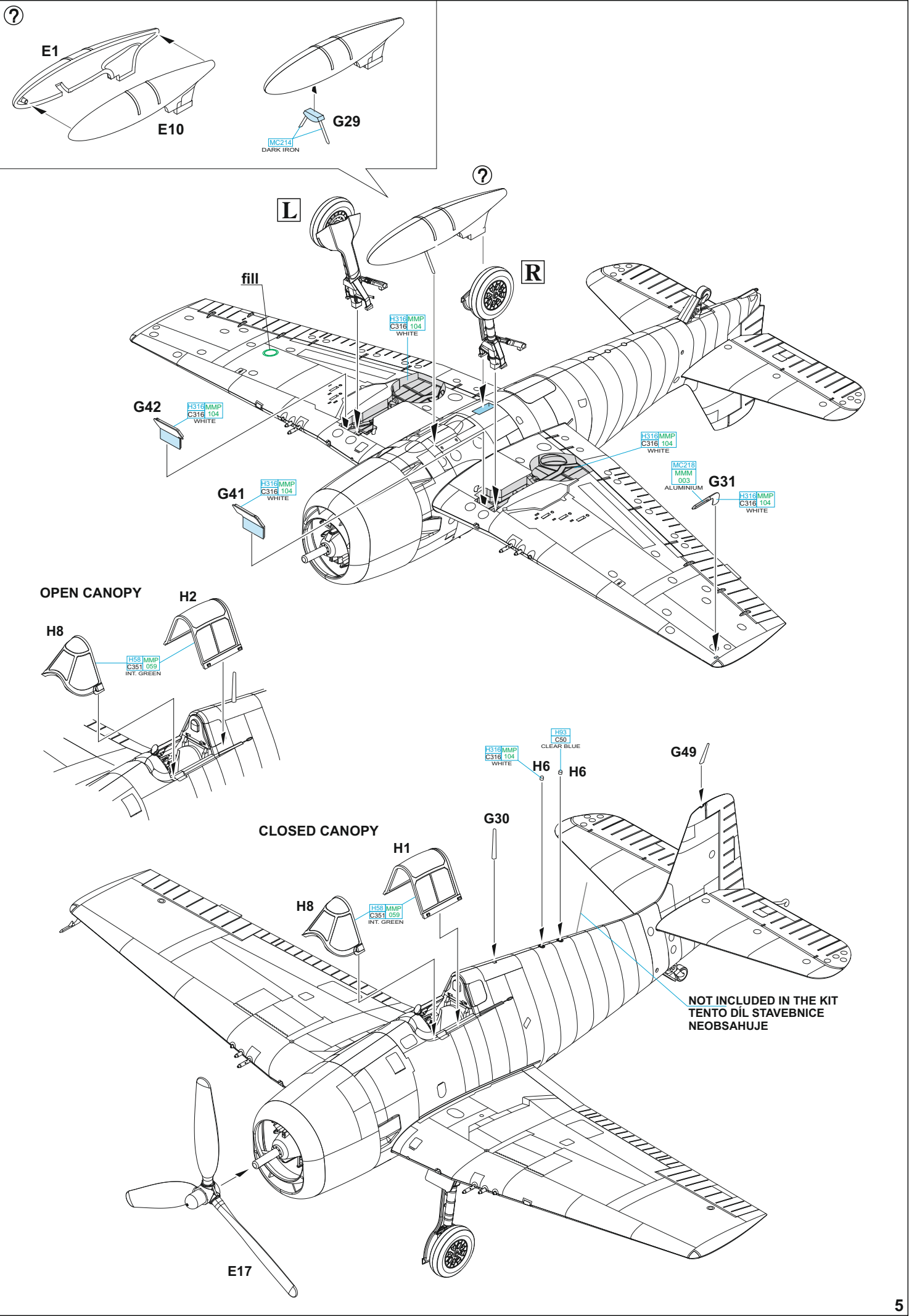

A VF-27, USS Princeton, October 1944

The most striking markings applied to the Hellcat were applied to the aircraft of VF-27 on the USS Princeton (CVL-23). The sharkmouth and bloodshot eyes seared themselves into the memory of more than one Japanese pilot. The sharkmouth and eyes were applied to all the Hellcats serving with VF-27 by one of its pilots, Robert Burnell, and with them, wreaked havoc everywhere they operated in the Pacific. Over this span, they accounted for some two hundred downed enemy aircraft. The end of combat for VF-27 came about on October 24th, 1944, when the Princeton suffered a Japanese bomb hit. A major fire ensued, and the Princeton was finally sunk using torpedoes launched from friendly ships. Only a few aircraft that were in the air at the time landed on the USS Essex. One of them was this Hellcat, with the uncommon 'F11' marking and with two kill marks in the form of small Japanese flags below the cockpit.

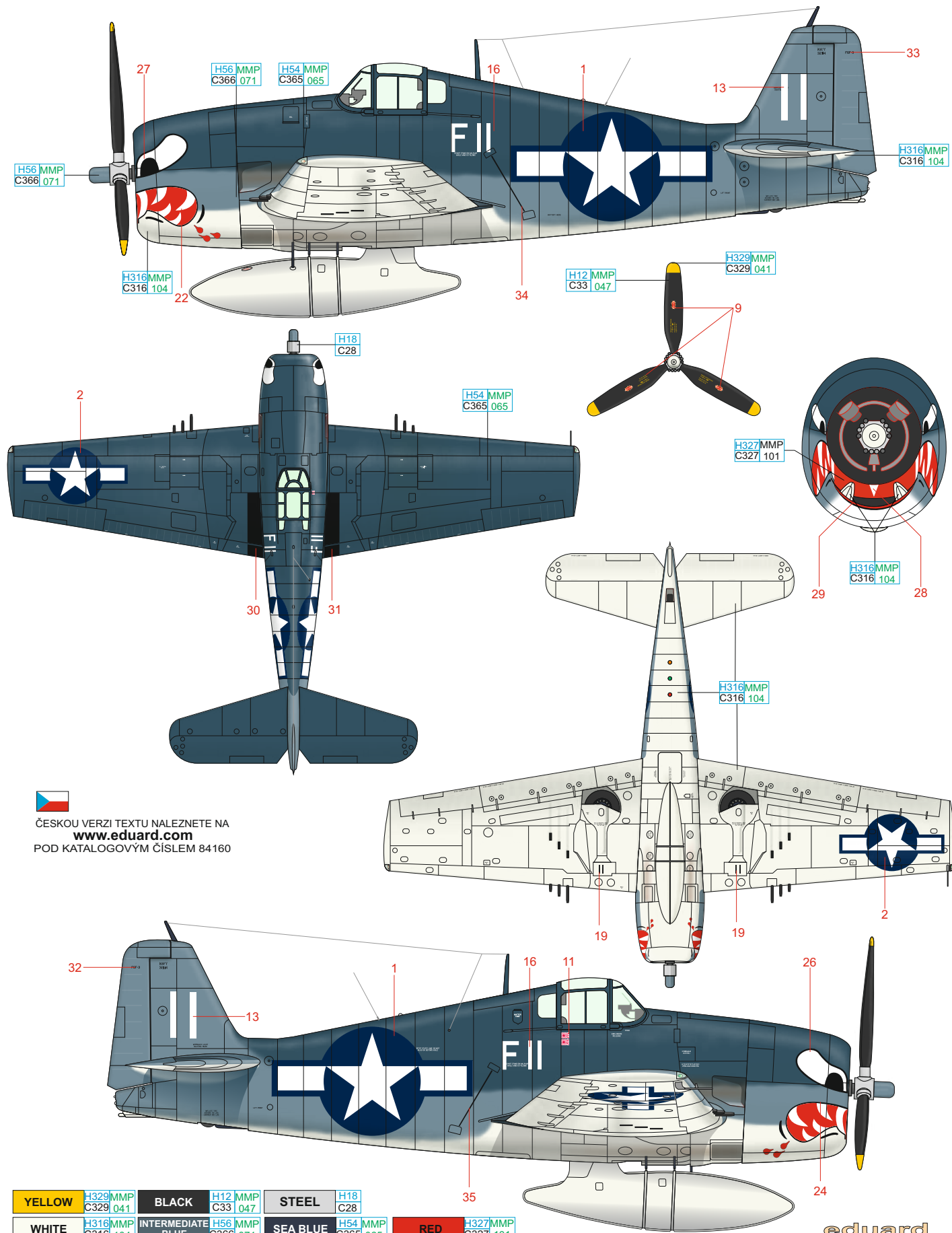

ČESKOU VERZI TEXTU NALEZNETE NA
www.eduard.com
 POD KATALOGOVÝM ČÍSLEM 84160

B flown by Lt. Arthur Singer, VF-15, USS Essex, October 24th - 25th, 1944

USS Essex (CV-9) participated with Task Force 58 in the Battle of Leyte Gulf that took place on October 24 – 25, 1944 in the Philippines. VF-15 Hellcats were launched from Essex as part of the second wave of U.S. aircraft that attacked the Japanese battleship Musashi and helped to sink her on October 24th. Arthur Singer, Jr. achieved ace status on September 12th, 1944, downing a J2M Jack fighter over Cebu. He was awarded the Distinguished Flying Cross for his extraordinary achievements while participating in aerial combat on October 25th, 1944. Singer's final tally was ten victories.

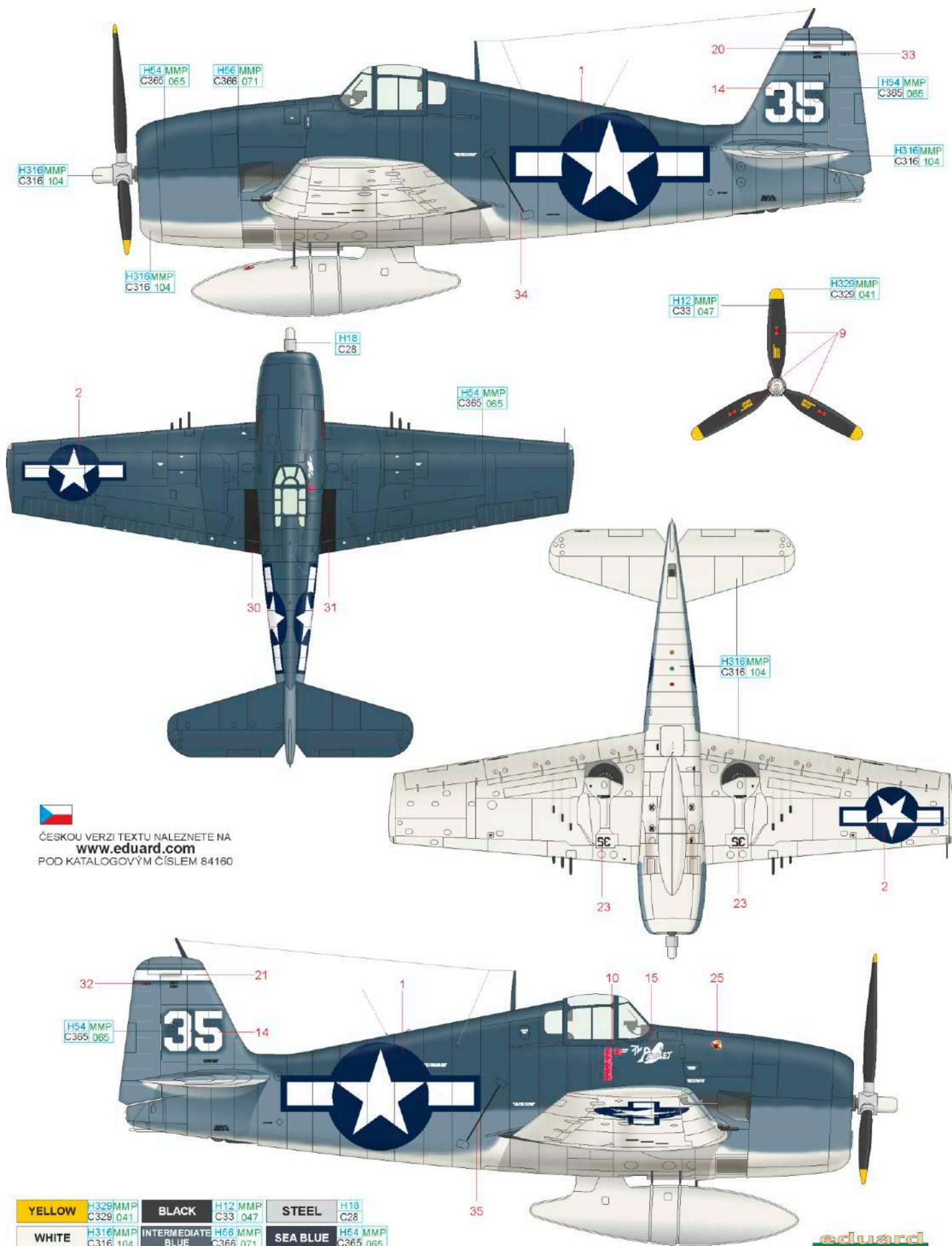

ČESKOU VERZI TEXTU NALEZNETE NA www.eduard.com

POD KATALOGOVÝM ČÍSLEM 84160

eduard

