

MiG-29 "FULCRUM C"

G.W.H.™

1/48 SCALE L4813 9-13 米格-29“支点C”前线战斗机 9-13型



• Special thanks to Mr. Alexander Drannikov and Mr. Yufei Mao.

The Mikoyan MiG-29 (Russian: **Микоян и Гуревич МиГ-29**; NATO reporting name: "Fulcrum") is a fourth-generation jet fighter aircraft designed in the Soviet Union for an air superiority role. Developed in the 1970s by the Mikoyan design bureau, it entered service with the Soviet Air Force in 1983, and remains in use by the Russian Air Force as well as in many other nations. The NATO name "Fulcrum" was sometimes unofficially used by Soviet pilots in service.

The MiG-29 was first publicly seen in the West when the Soviet Union displayed the aircraft in Finland in July 1986. Two

米格-29是前苏联米高扬-格列维奇飞机设计局设计的双发高性能制空战斗机。北约组织给予的绰号是“支点”（Fulcrum）。米格-29于1983年开始装备前苏联空军，并在1986年6月的访问芬兰过程中首次向西方亮相，随后于1988年参加英国范堡罗航展，以其高机动性飞行表演轰动一时。米格-29的海外用户包括了阿尔及利亚、孟加拉、保加利亚、古巴、捷克斯洛伐克、厄立特里亚、东德、匈牙利、印度、伊朗、伊拉克、马来西亚、缅甸、朝鲜、秘鲁、波兰、罗马尼亚、塞尔维亚、斯洛伐克、叙利亚与也门。另外，苏联解体时，白俄罗斯、哈萨克、摩达维亚、土库曼、乌克兰、乌兹别克等前加盟共和国亦自

MiG-29s were also displayed at the Farnborough Airshow in Britain in September 1988.

MiG-29 9-13 is mainly used by Soviet/Russian Air Force, former CIS countries, North Korea, Myanmar and Peru(now updated to MiG-29SMP), etc.. The NATO code name for this variant is "Fulcrum C". MiG-29 Product 9-13 is similar in external appearance to older MiG-29 9-12 airframes, except for the dorsal hump behind the cockpit canopy. The dorsal hump, while most of its volume is used for the new L203BE Gardeniya-1 ECM system, earns the nickname "Fatback" for MiG-29 9-13 in service.

前苏联空军分得了大批数量。这些飞机状况不一，其中许多至今仍在其新用户的手中服役。

米格-29 9-13于1984年起开始服役于前苏联空军，目前用户有俄罗斯空军、前独联体各国空军、北朝鲜、缅甸及秘鲁(已升级至MiG-29SMP)等国。北约为其取的识别代号为“支点C”。

米格-29 9-13大致与米格-29 9-12相同，但换装大型内置油箱并加装L-203BEGardeniya雷达干扰器，故机背略有隆起，也得到了“Fatback”的昵称。

△注意:

1. 勿於近火處使用膠水或油漆，並打開窗戶保持空氣流通。
2. 塗料的號碼請參考本欄以下的說明。本品本身不包括膠水和塗料。
3. 自膠架中取出部件時，應用模型專用剪，並用介刀或小挫除去多餘膠料。
4. 各圖形的含義可參考本欄以下的說明。

△CAUTION:

1. When you use glue or paint, do not use near a open flame, and use in a well-ventilated room.
2. See below for the color list. Glue and paint are not included in this kit.
3. When you take parts off the runner frame, use the modeling scissors and trim excess plastic with a cutter or a file.
4. See below for the meaning of symbols.

組み立ての注意:

1. 接着剤や塗料は火の近くで使わないで下さい、使用の際は換気をよくして下さい。
2. 塗料指定のは下記のとおりです、接着剤や塗料は入っていないので別に求めて下さい。
3. 部品のランナーから切り離す時は模型用ハサミ等を使い、余分な部分はカッターやヤスリ等で仕上げして下さい。
4. 組立図のサインマークは下の説明を御覧下さい。



FILL HOLE
填平
穴を埋めて下さい



APPLY DECAL
水印粘紙
デカールを貼って下さい



CUT OFF
切除
切り取って下さい



BEND
弯折
折り曲げて下さい



x2 MAKE TWO SET
制作两组
2個作って下さい



DO THE SAME ON THE OPPOSITE
另一侧相同制作
反対側も取り付けます



CEMENT
胶水
接着して下さい



OPEN HOLE
钻孔
穴をあけて下さい



OPTIONAL
选择使用
どちらかを選んで下さい



NO CEMENT
不用胶水
接着しないで下さい



INSTANT GLUE FOE METAL
瞬間胶
(金属用)



BE CAREFUL
注意
注意して下さい

A Parts X 1



B Parts X 1

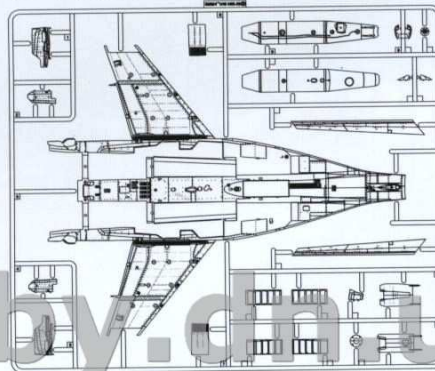

C Parts X 1

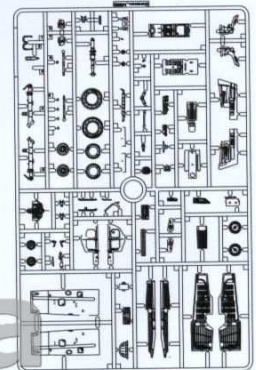

D Parts X 1

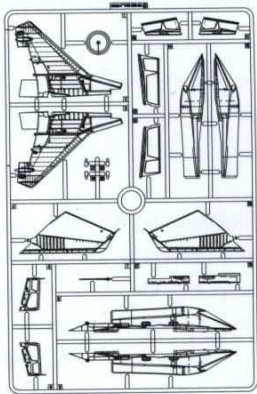

H Parts X 1

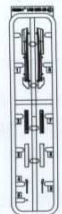

G Parts X 1

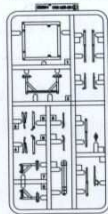

E Parts X 1



I Parts X 2

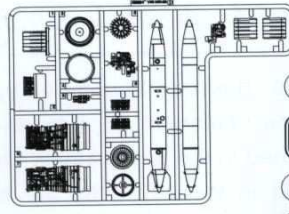

PE Parts X 1



P Parts X 4

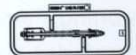

L Parts X 2

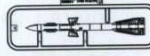

J Parts X 2

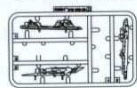

J5 Parts X 2

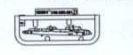

DA Parts X 1



DB Parts X 1

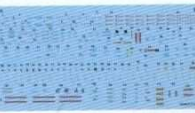

Film



C|000 GSI CREOS Mr.COLOR

00-000 ACRYLICOS VALLEJO

C 1	70-842	光泽白色	Gloss White	SM 03	71-073	烧铁色	Metallic Burnt Iron
C 2	70-861	光泽黑色	Gloss Black	C 317	70-991	灰色 FS36231	Grey FS36231
C 8	70-997	银色	Silver	C 308	71-050	灰色 FS36375	Grey FS36375
C 73	71-012	飞机灰色	Aircraft Grey	C 305	71-053	灰色 FS36118	Grey FS36118
C 92	70-950	半光泽黑色	Semi-gloss Black	C 325	70-986	灰色 FS26440	Grey FS26440
C 33	71-057	消光黑色	Flat Black	C 320	—	浓松叶绿色	Dark Pine Green
C 3	71-084	光泽红色	Gloss Red	C 319	71-017	浅松叶绿色	Light Pine Green
C 118	71-101	浅蓝灰色	Light Blueish Grey	MC 213	71-072	不锈钢色	Stainless
C 6	70-970	光泽绿色	Gloss Green	MC 214	70-865	暗铁色	Dark Iron
C 61	71-073	烧铁色	Metallic Burnt Iron	C 47	70-934	透明红色	Clear Red
C 62	71-001	消光白色	Flat White	C 138	—	透明绿色	Clear Green
C 4	70-953	光泽黄色	Gloss Yellow	C 50	70-938	透明蓝色	Clear Blue
C 58	70-911	黄橙色	Yellow Orange	C 45	70-918	象牙色	Ivory
C 49	70-956	透明橙色	Clear Orange	C 306	71-049	灰色 FS36270	Grey FS36270
SM 07	70-790	镜面银色	Plate Silver	C 7	—	棕色	Brown

A

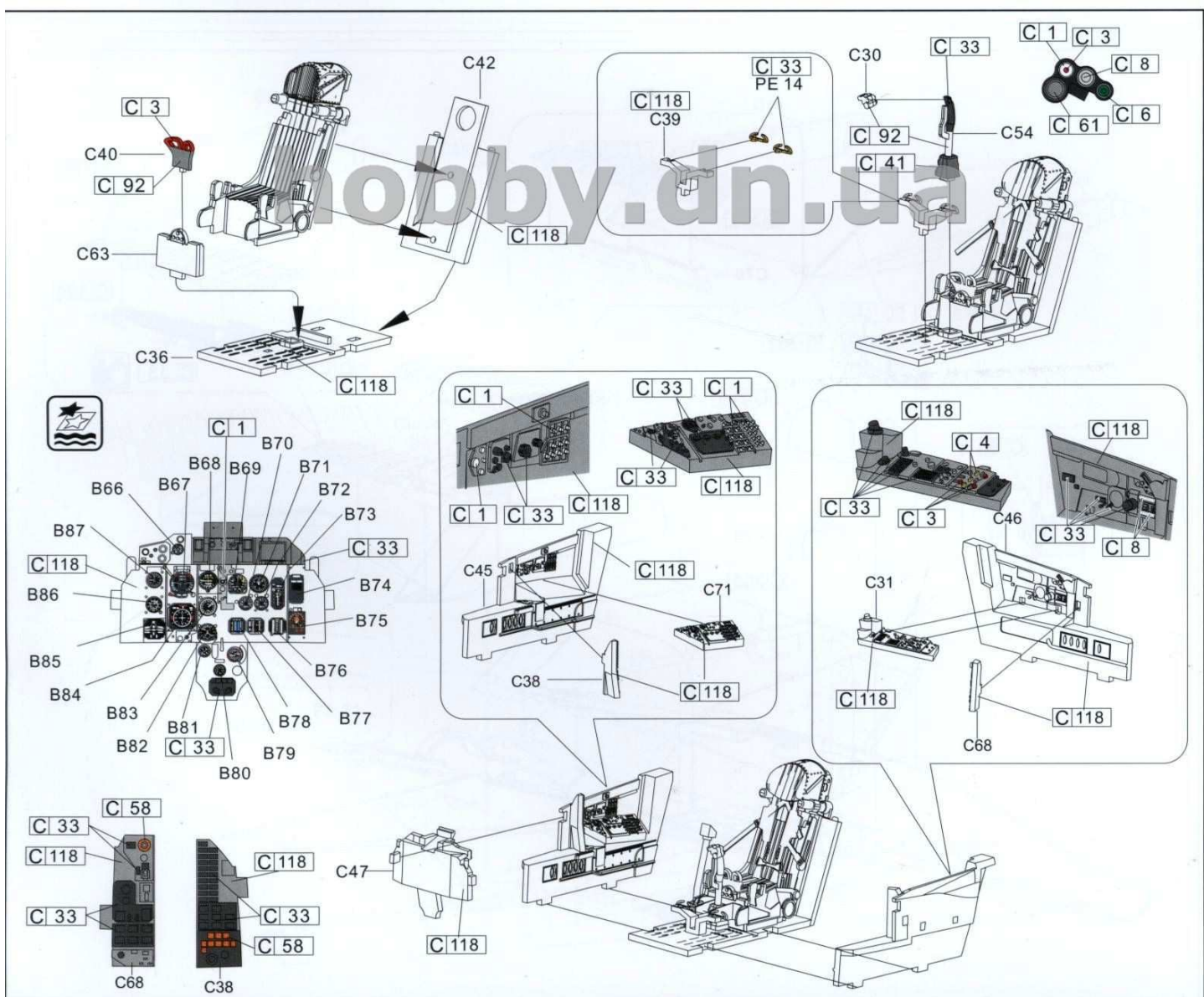
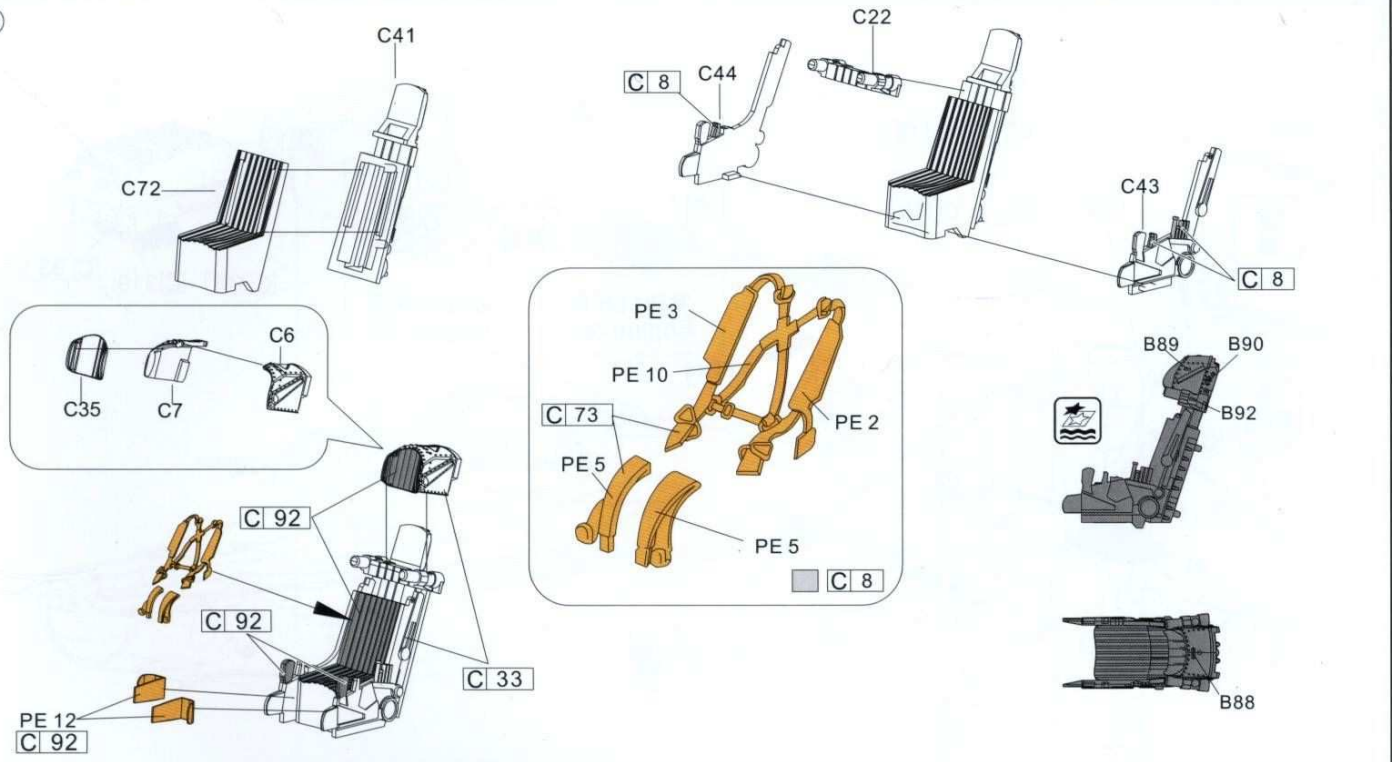

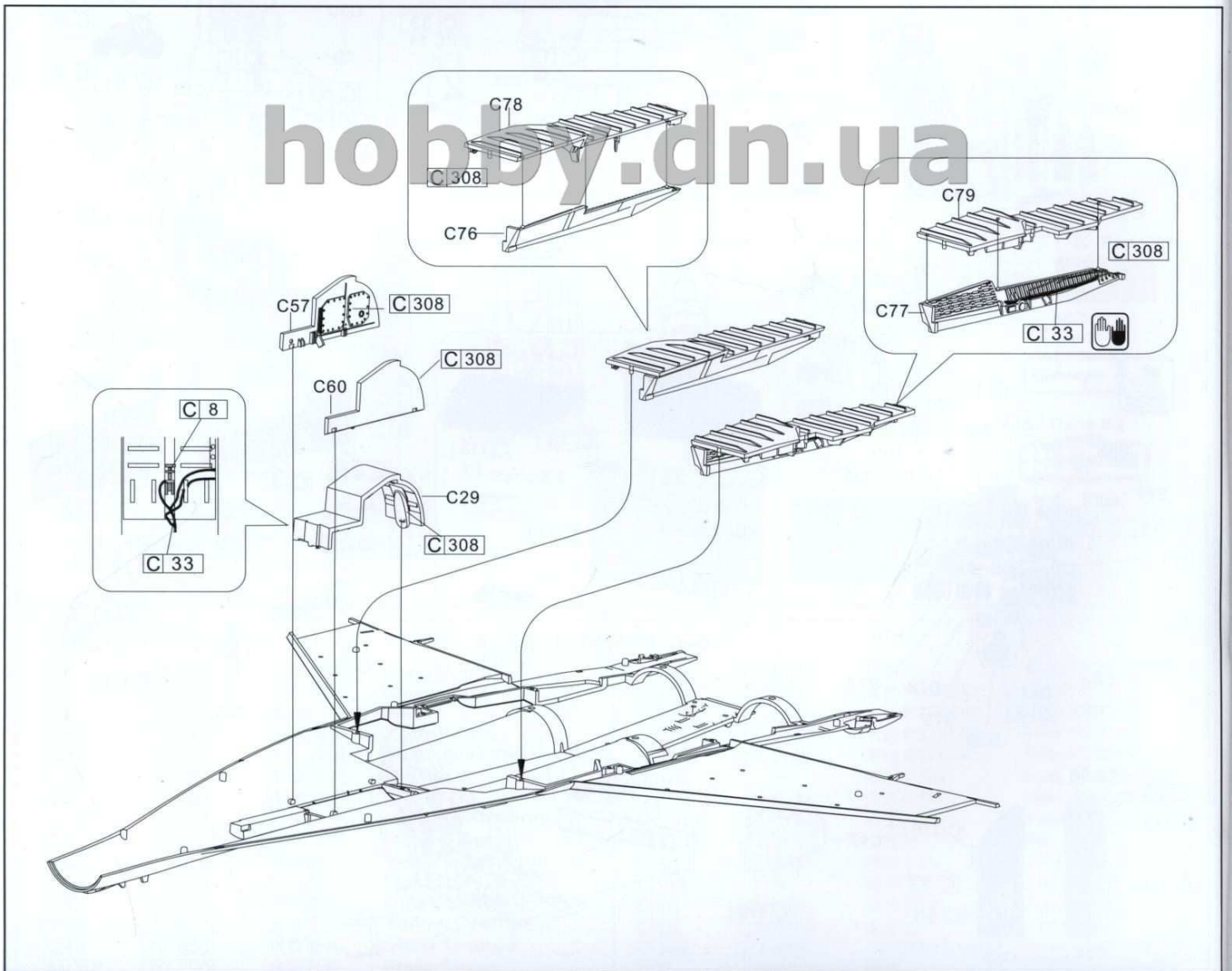
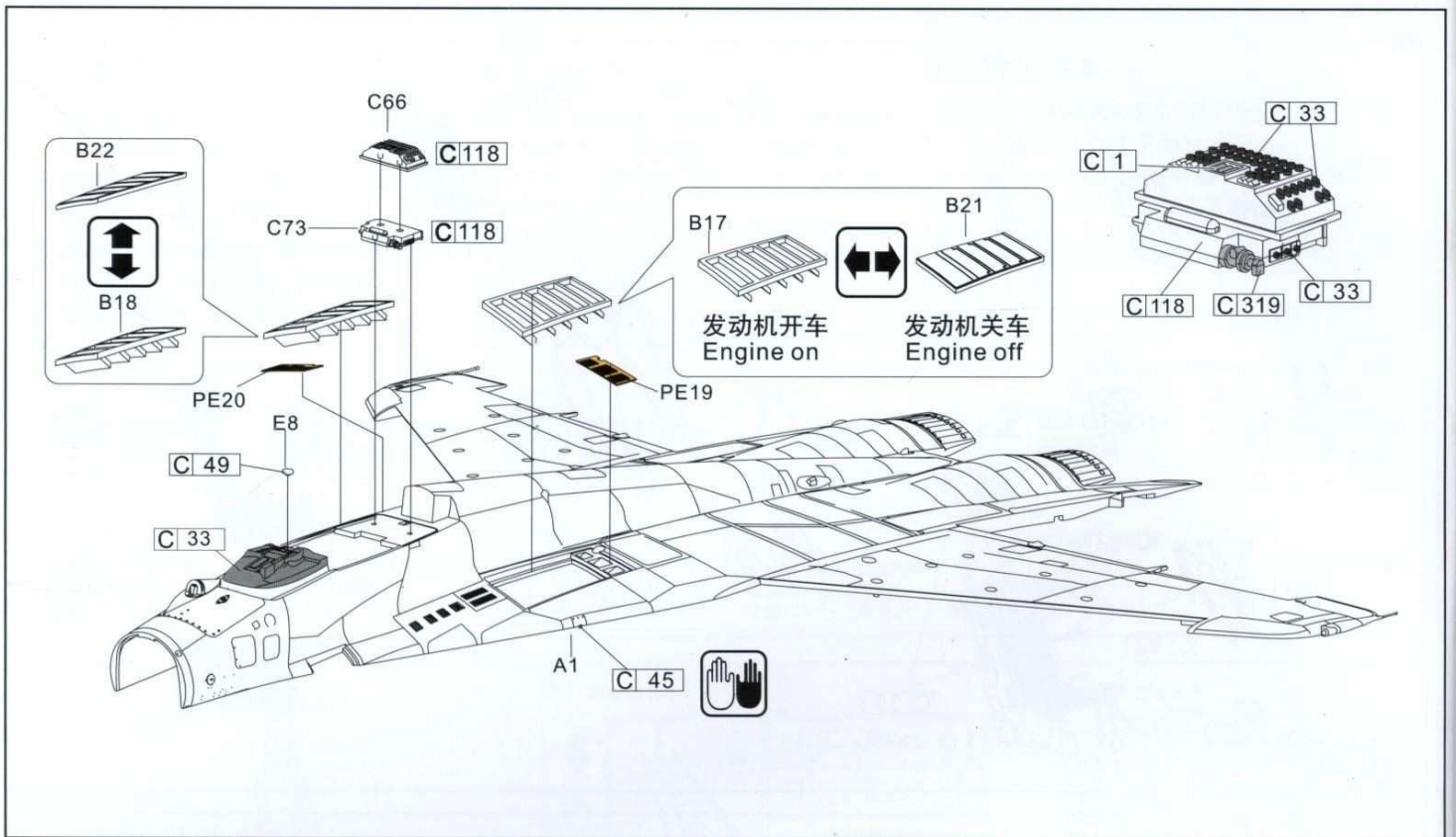

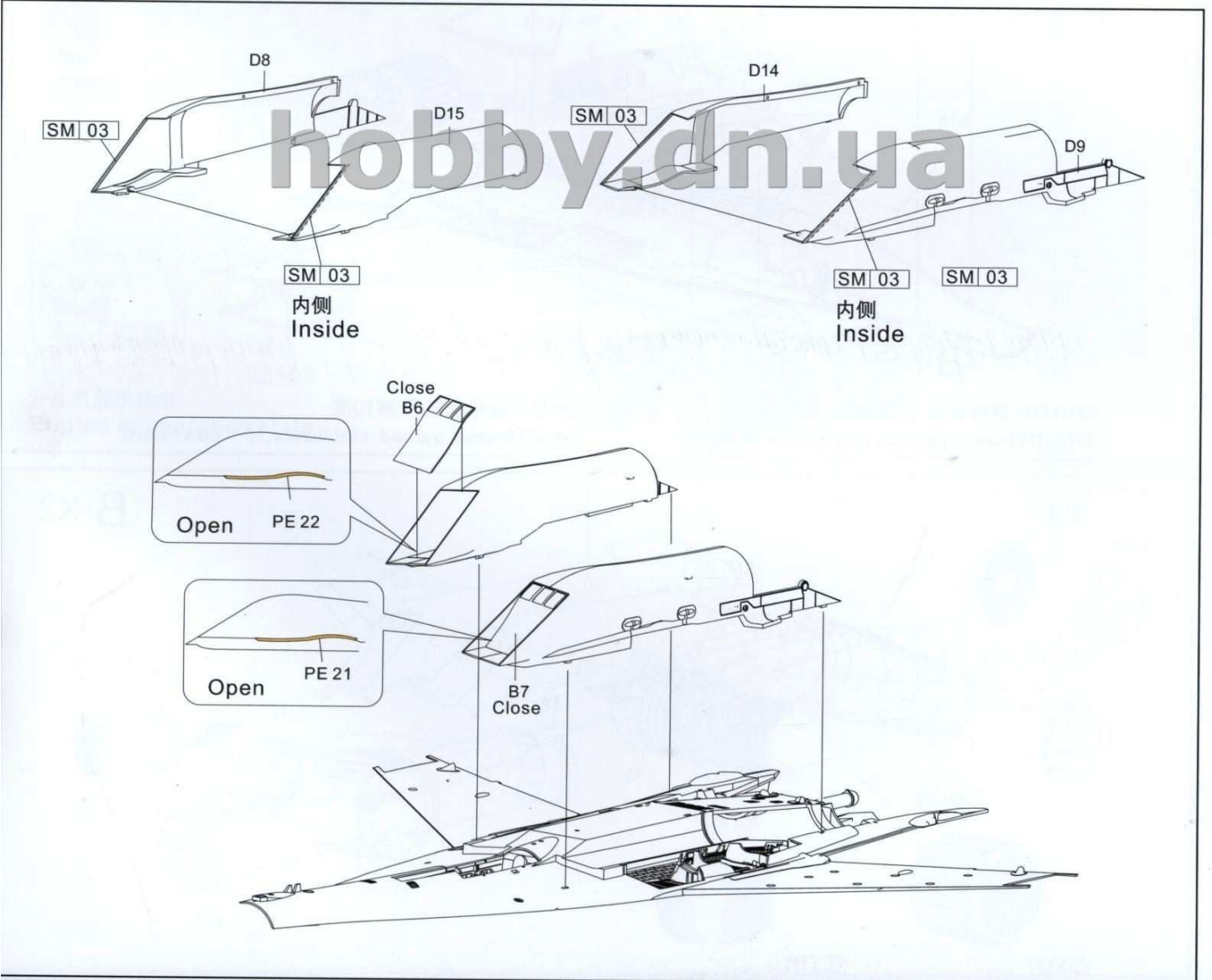
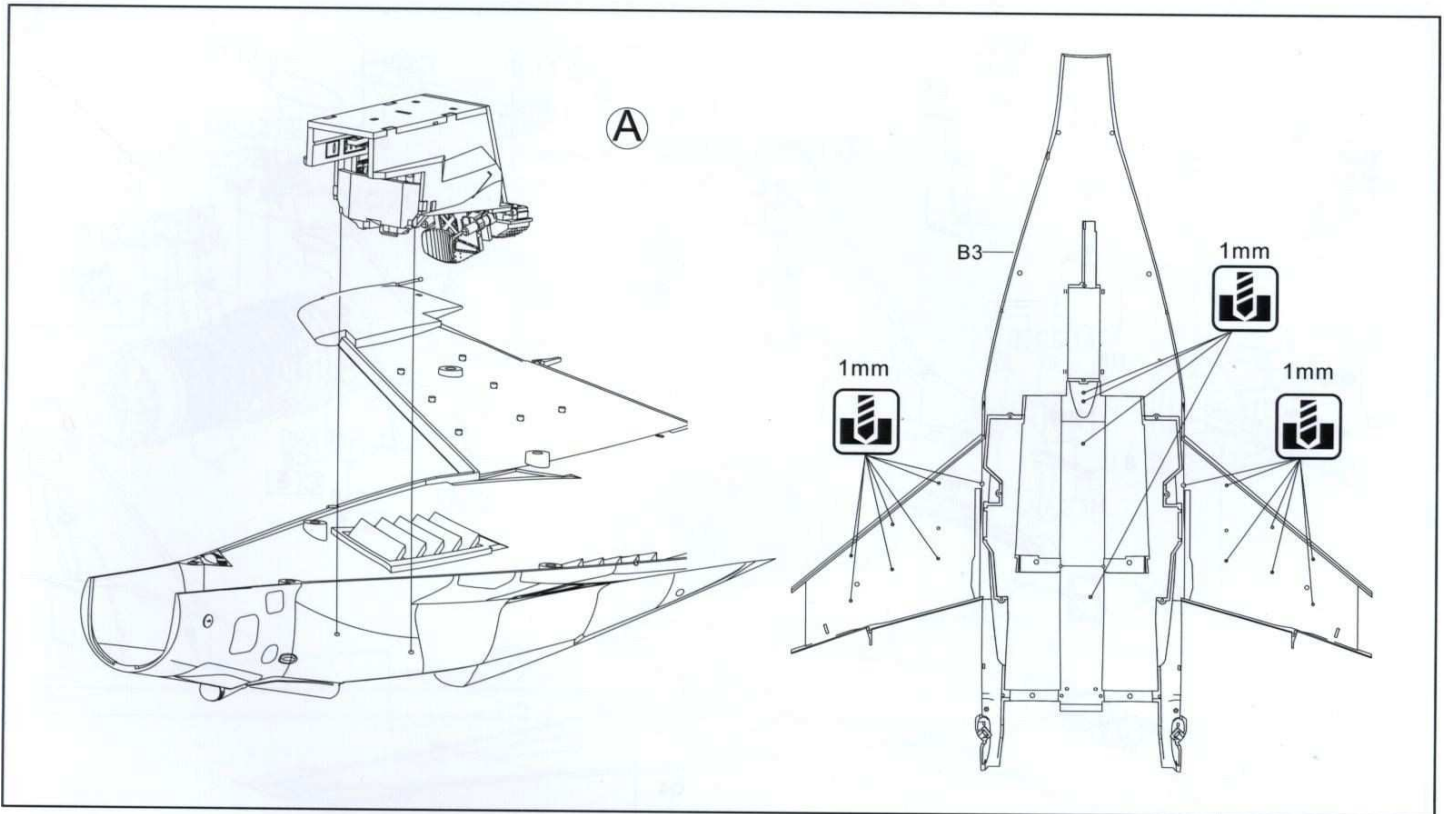

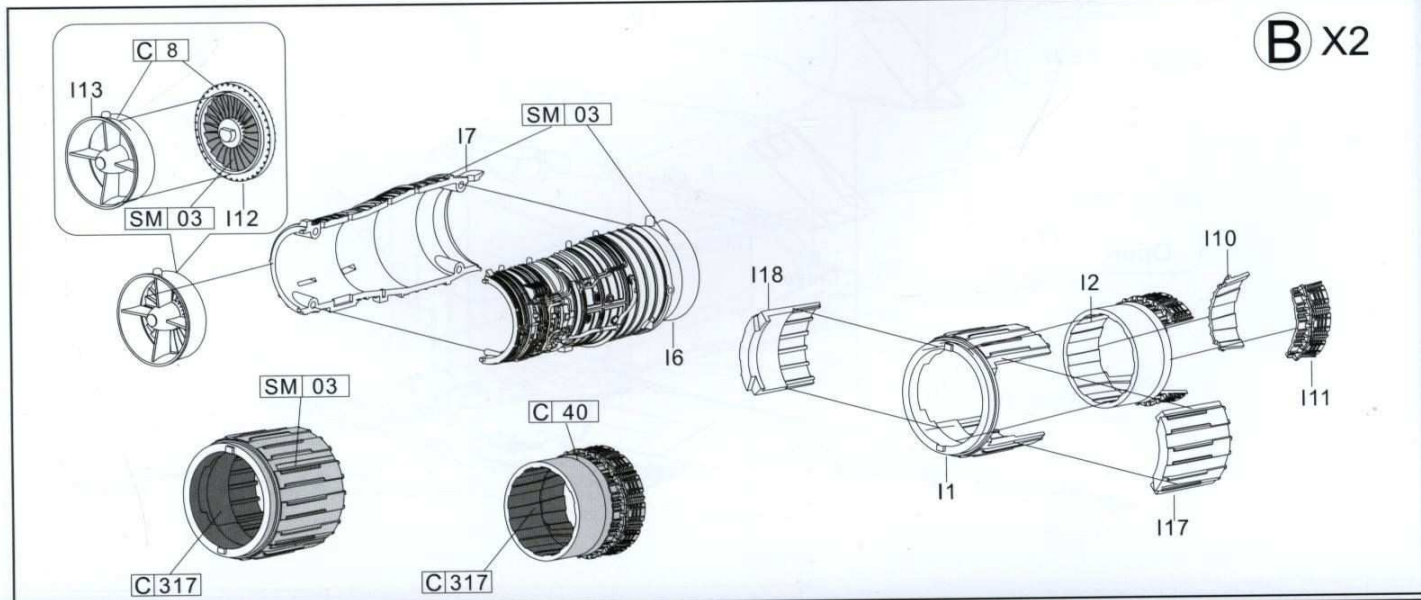
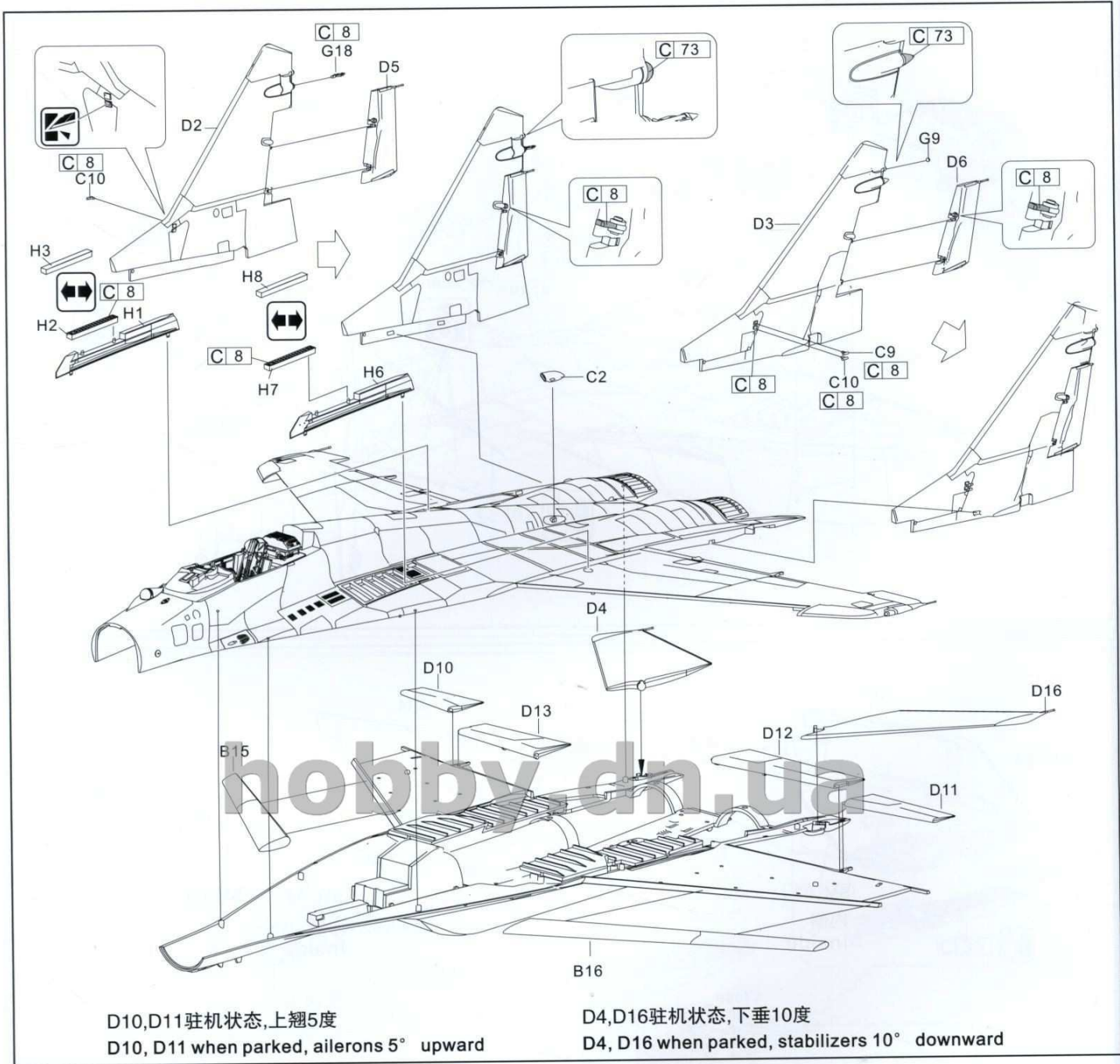

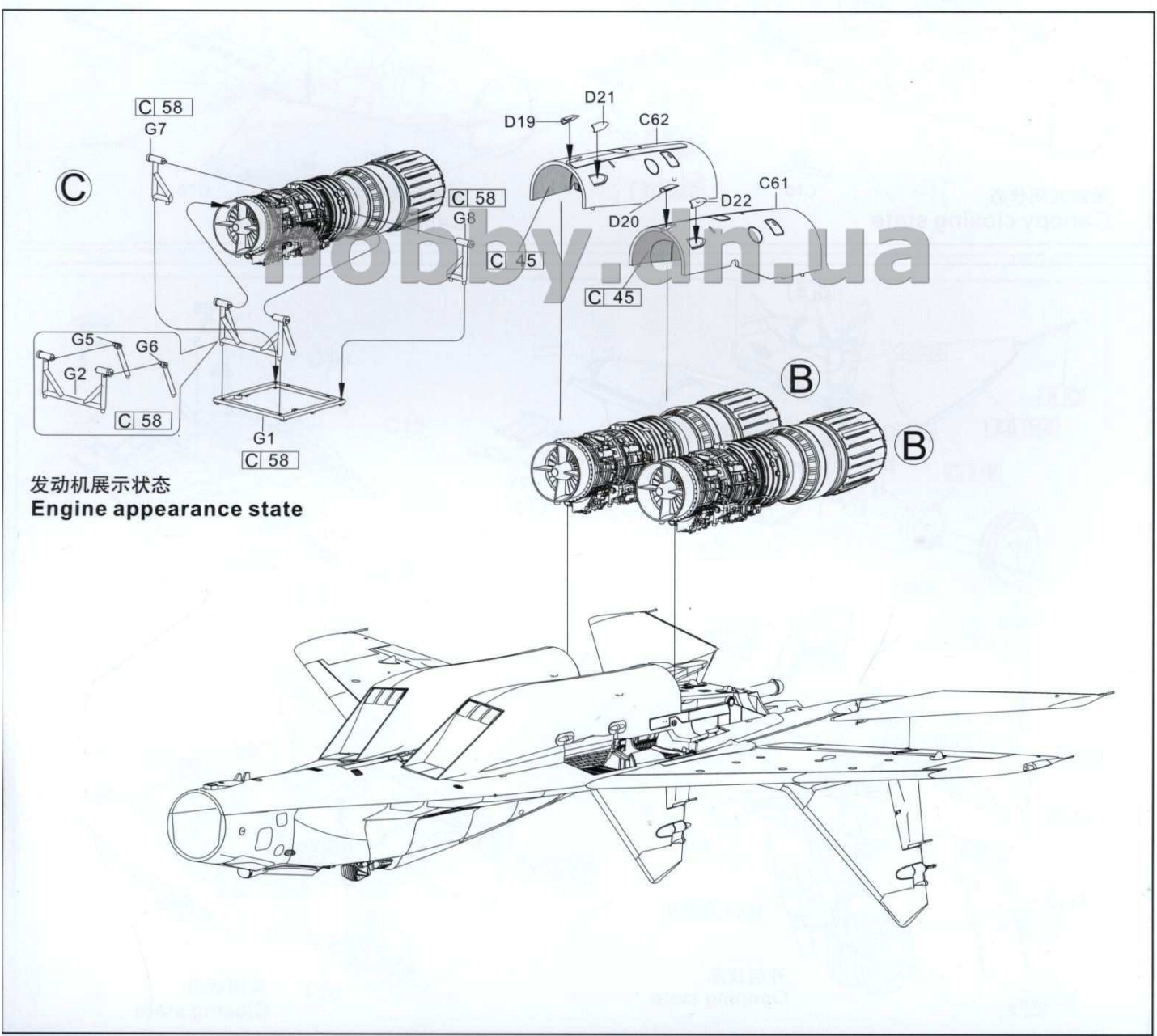
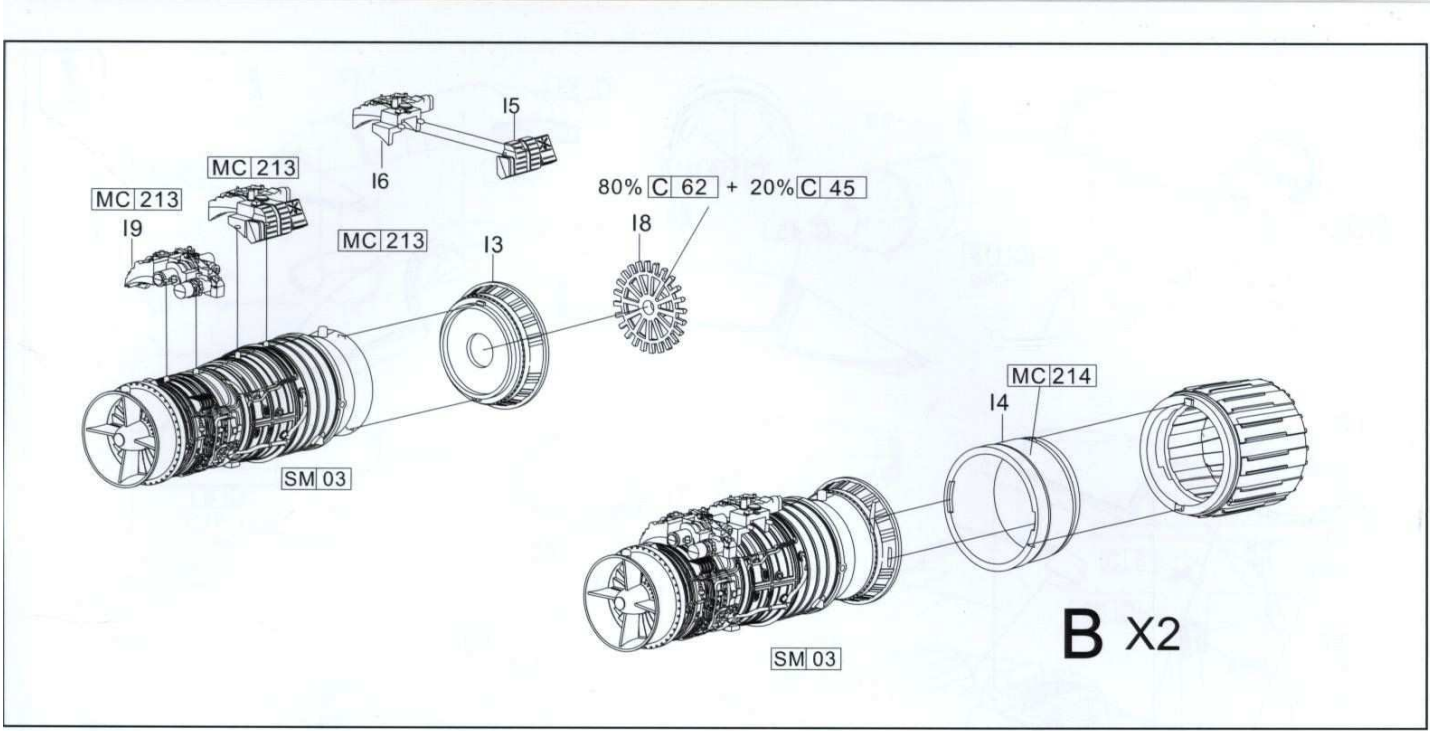

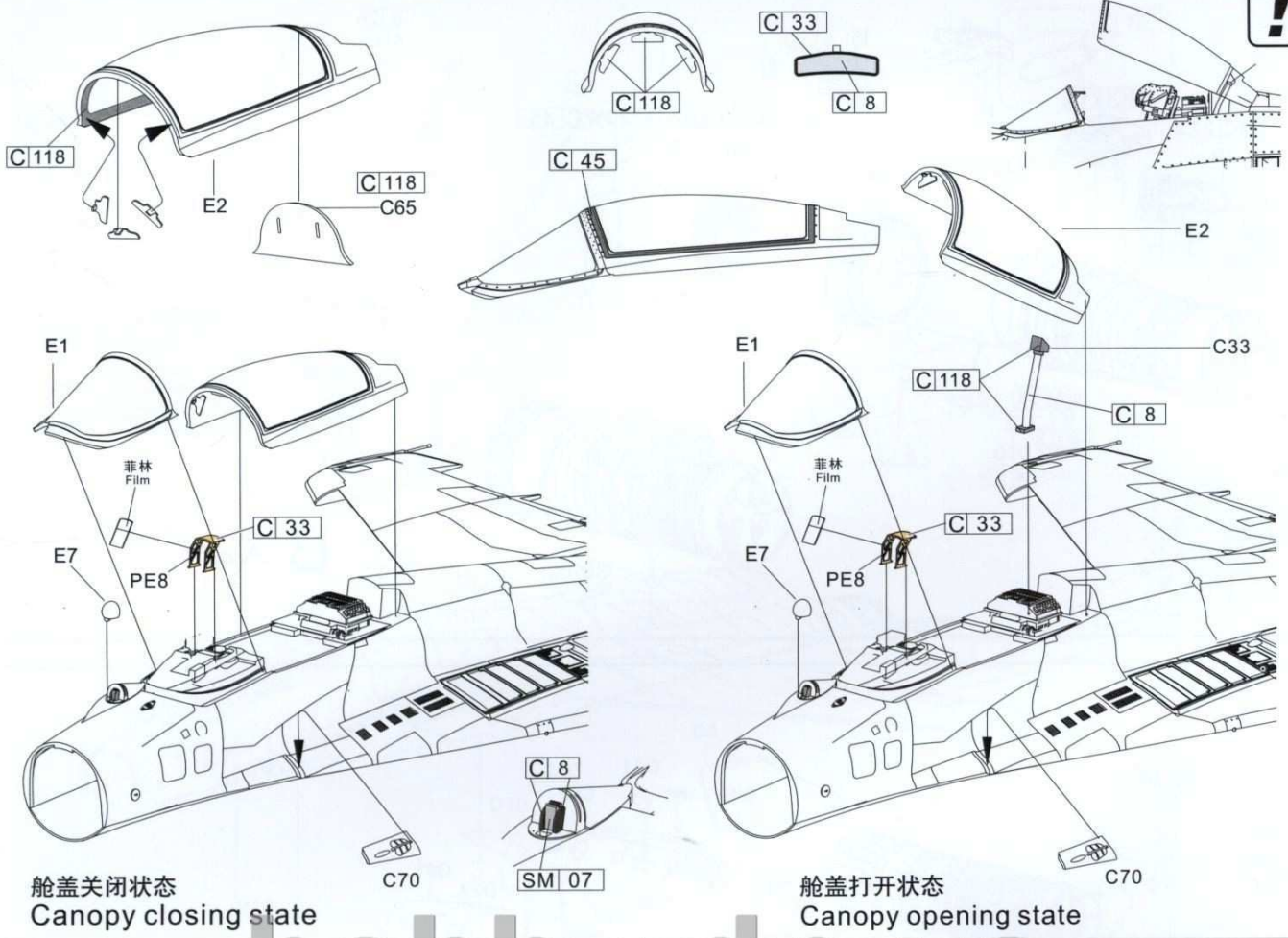

hobby.dn.ua

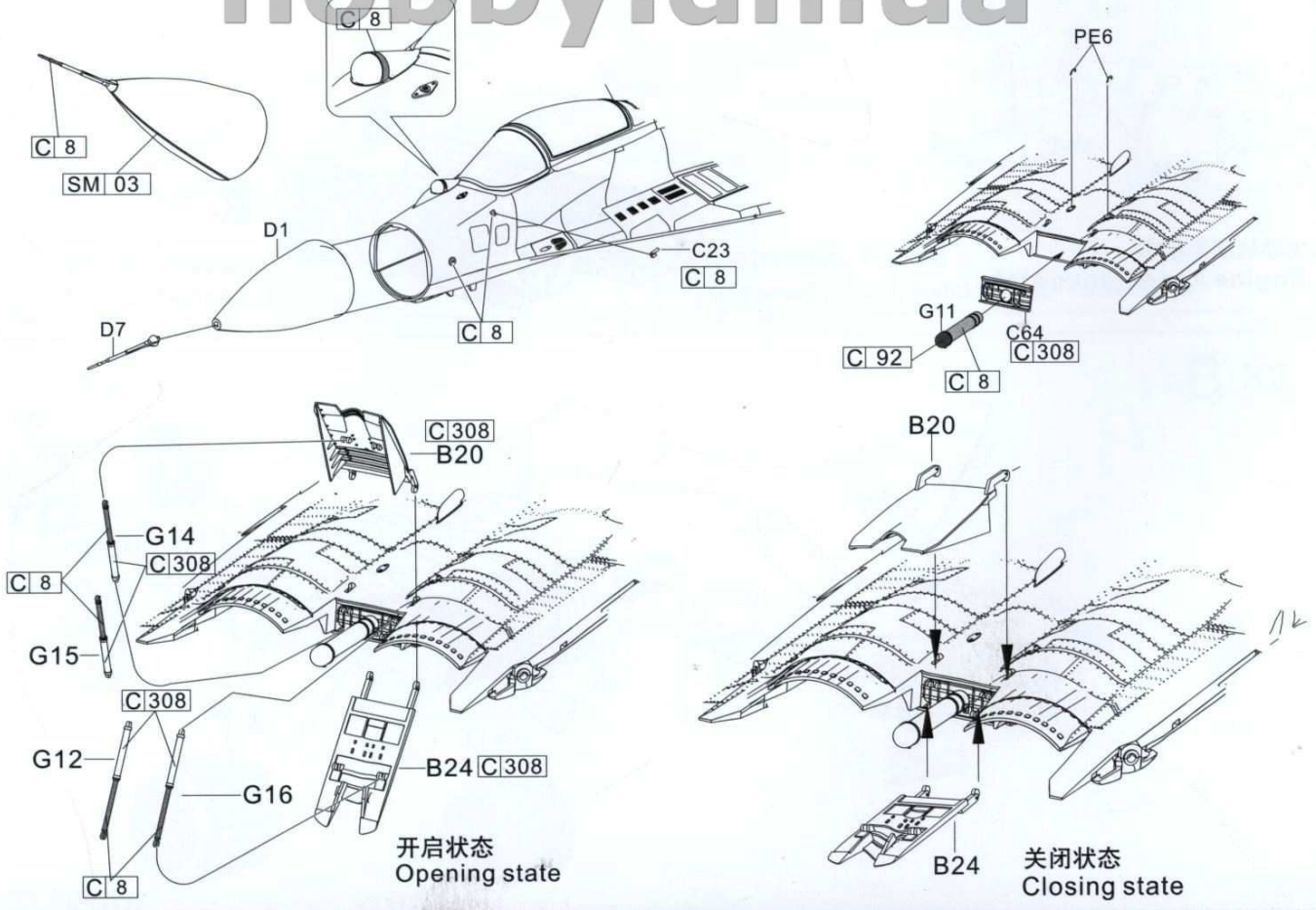

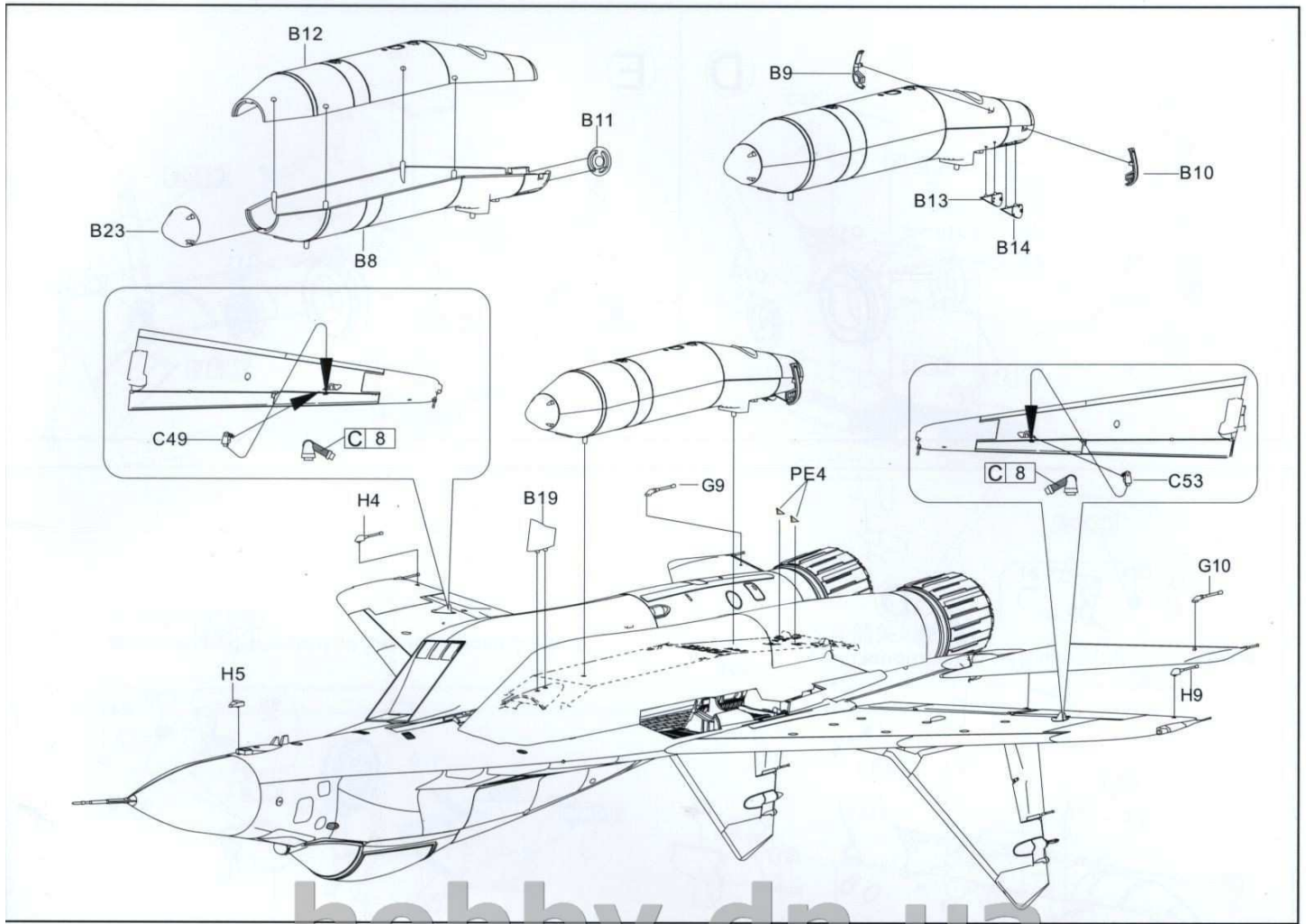

hobby.dn.ua

F

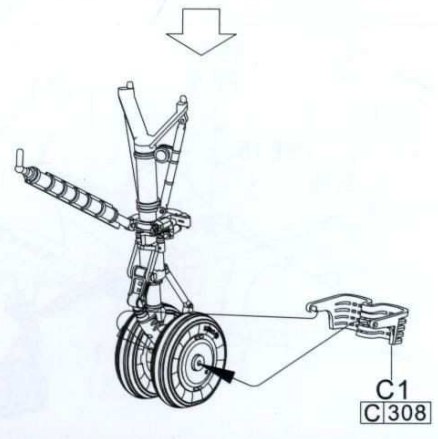
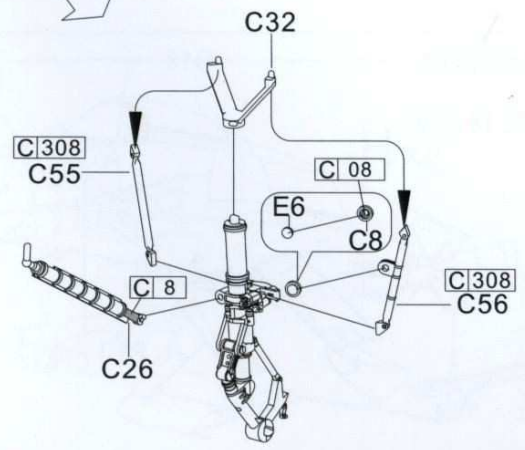
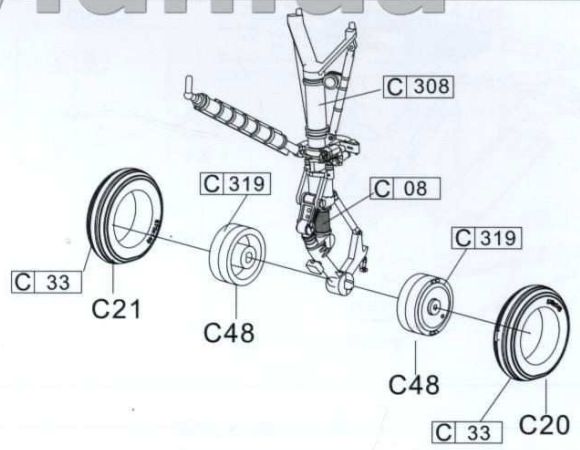
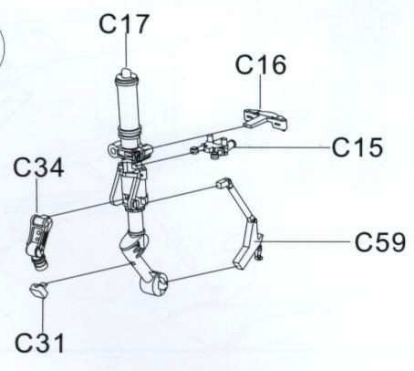

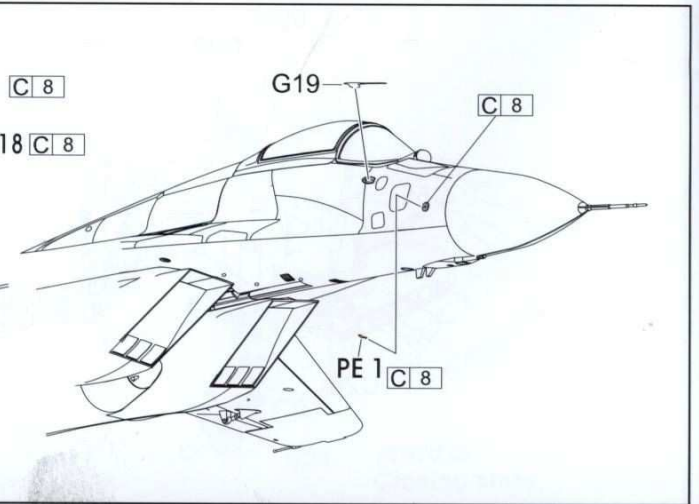
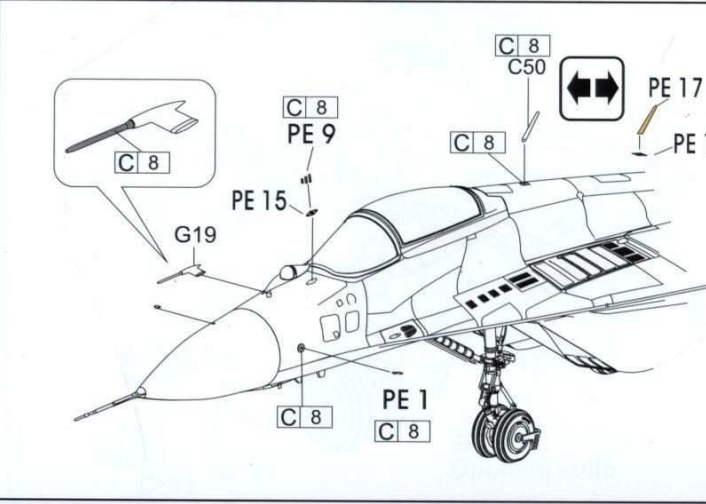
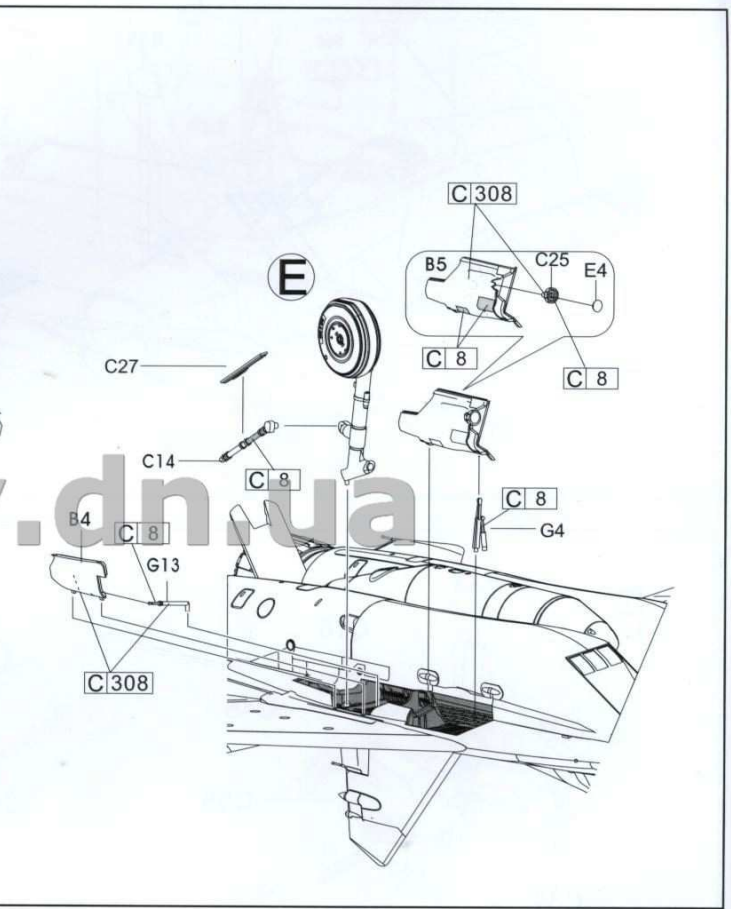
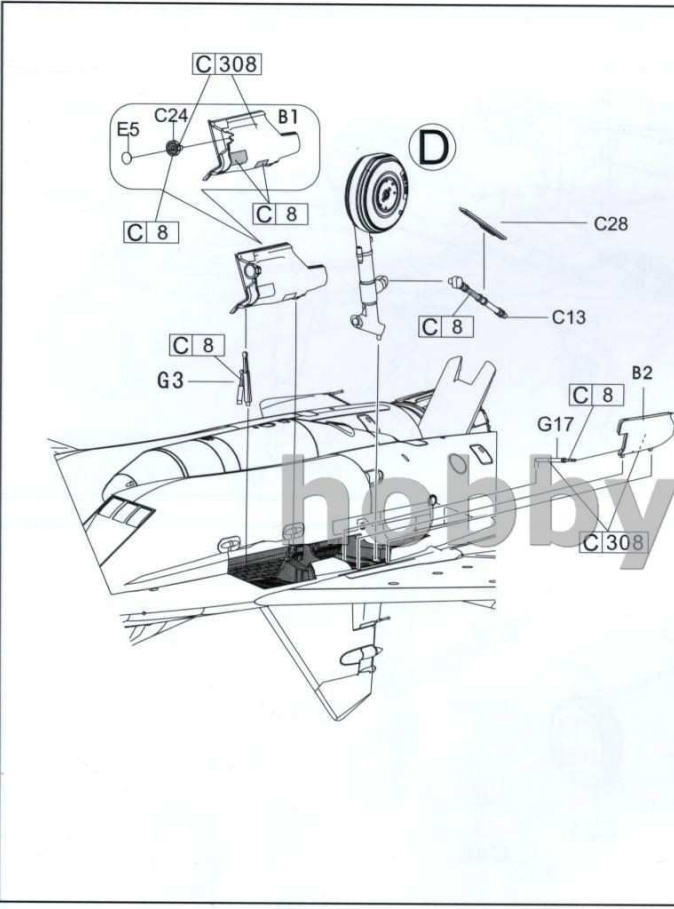
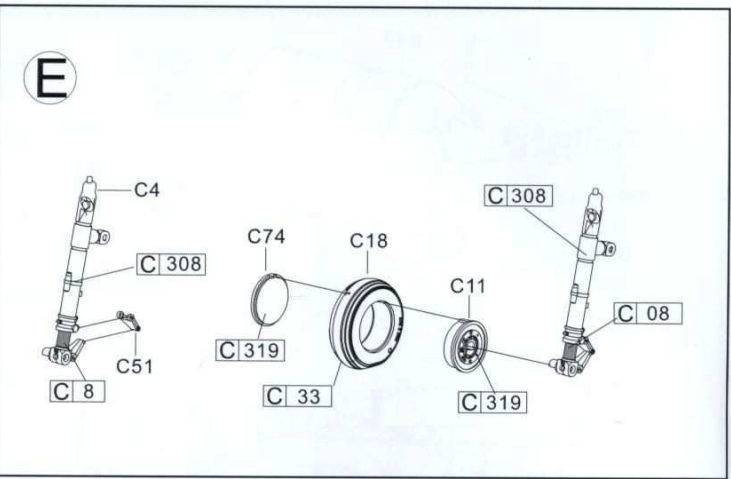
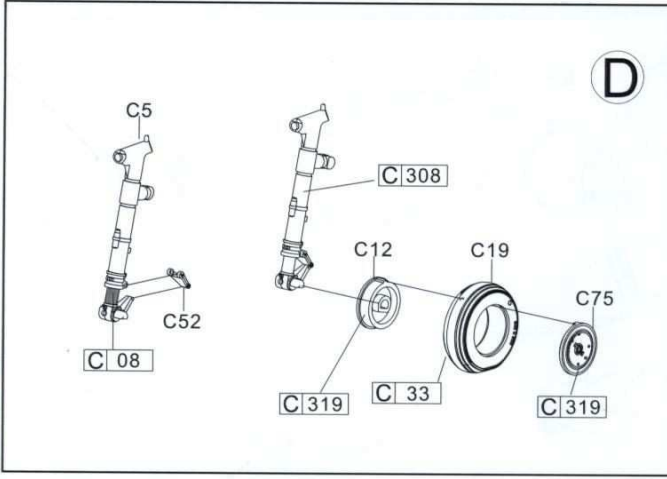

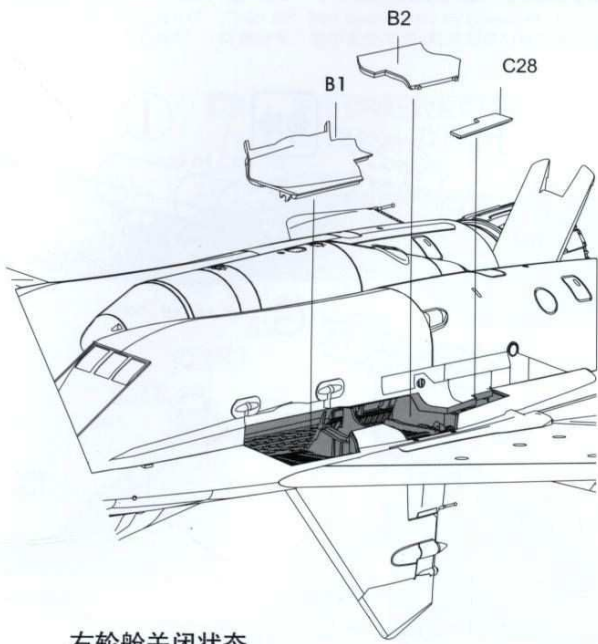

右轮舱关闭状态
Main landing gear bay in the right closing state

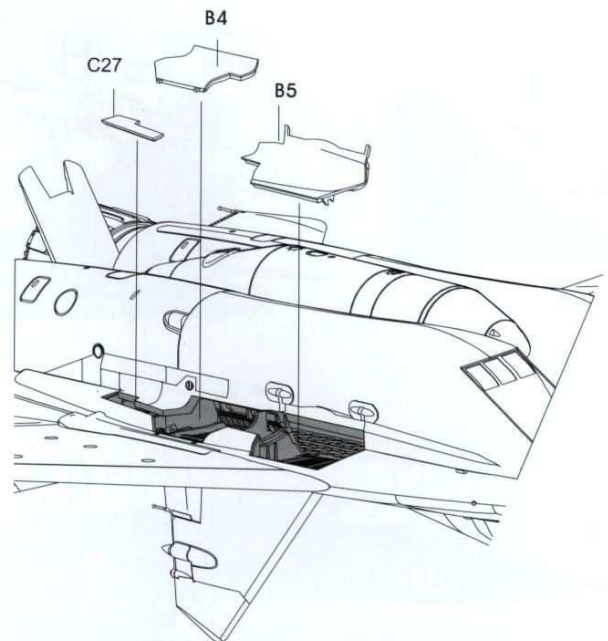

左轮舱关闭状态
Main landing gear bay in the left closing state

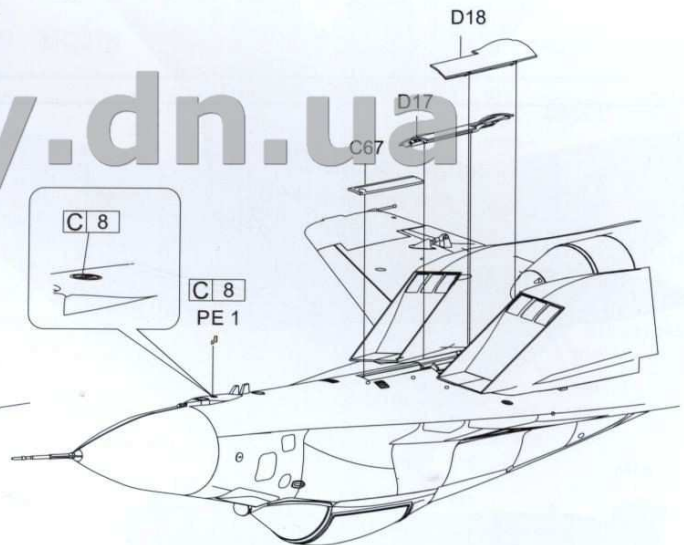
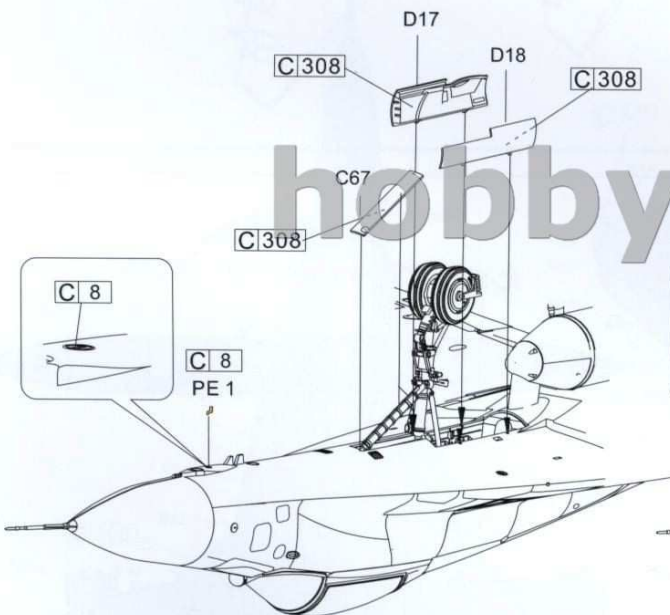

前轮舱关闭状态
Front landing gear bay closing state

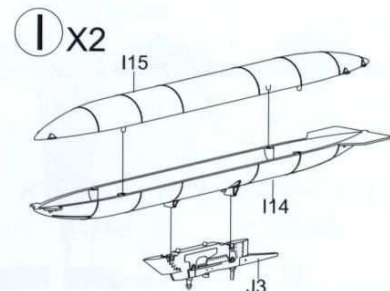
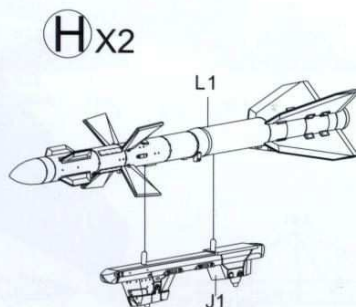
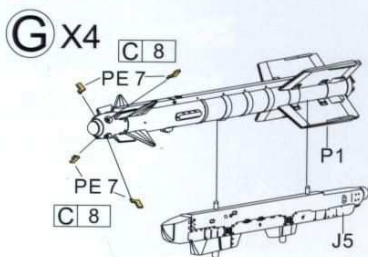

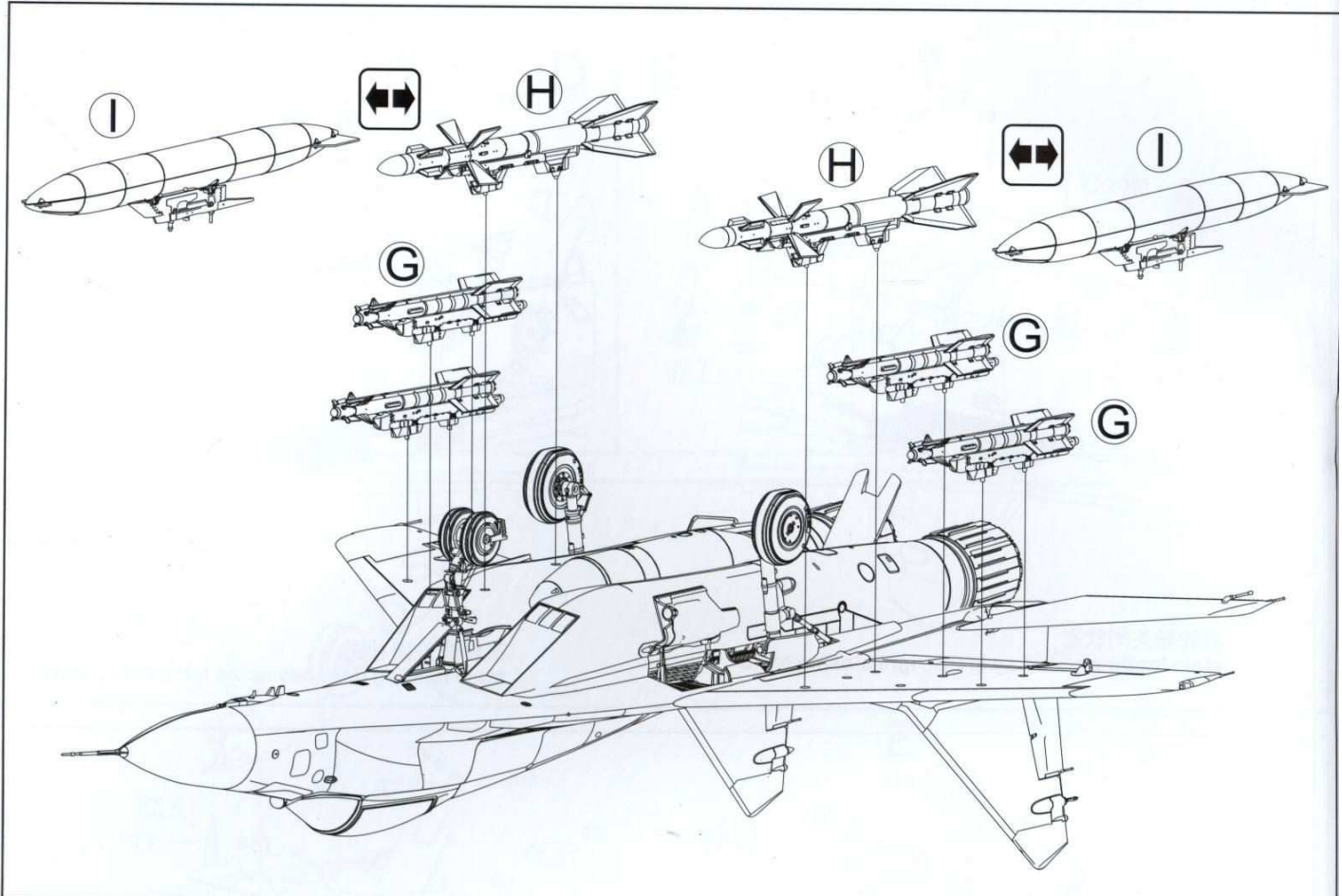

hobby.dn.ua

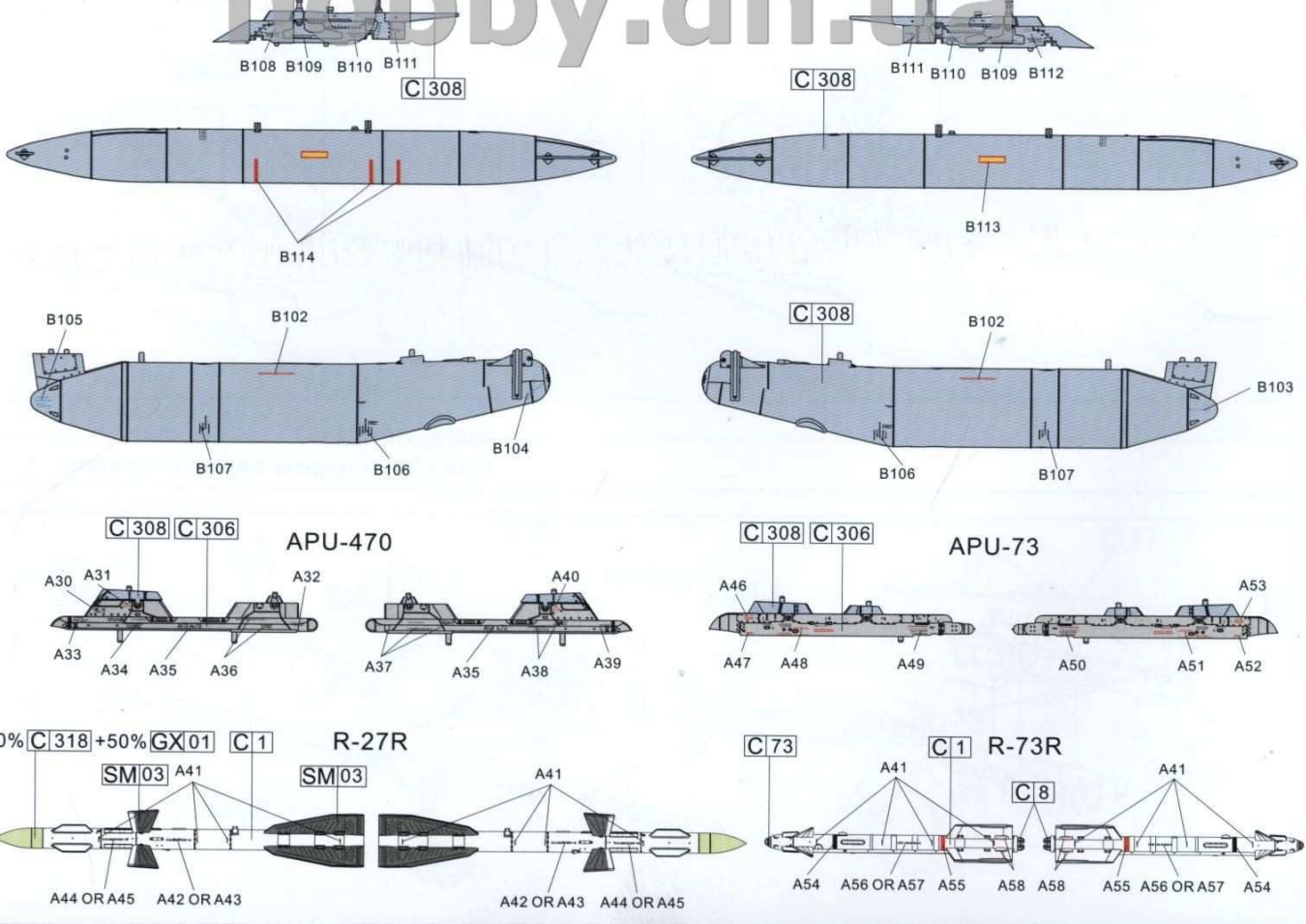

[4813] 1/48 MiG-29 9-13 "FULCRUM C" FIGHTER

MiG-29 9-13 "Fulcrum C" "Red 29" 31st GviAP, 51st Air Corps, 4th Air Army, Russian Air Force
米格-29 9-13 "支点C" "红色29号" 俄罗斯空军第4航空军第51联队第31近卫红旗歼击团

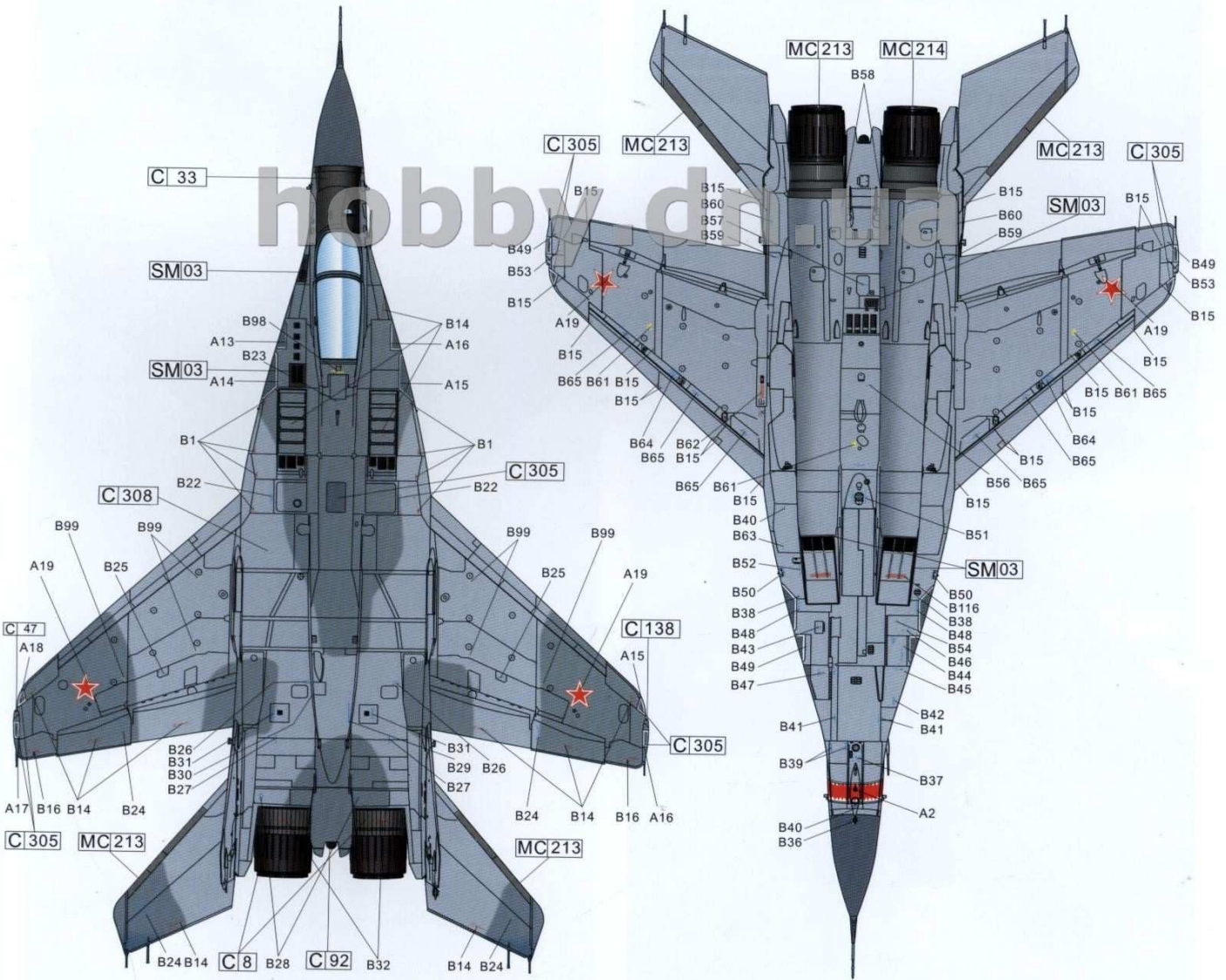
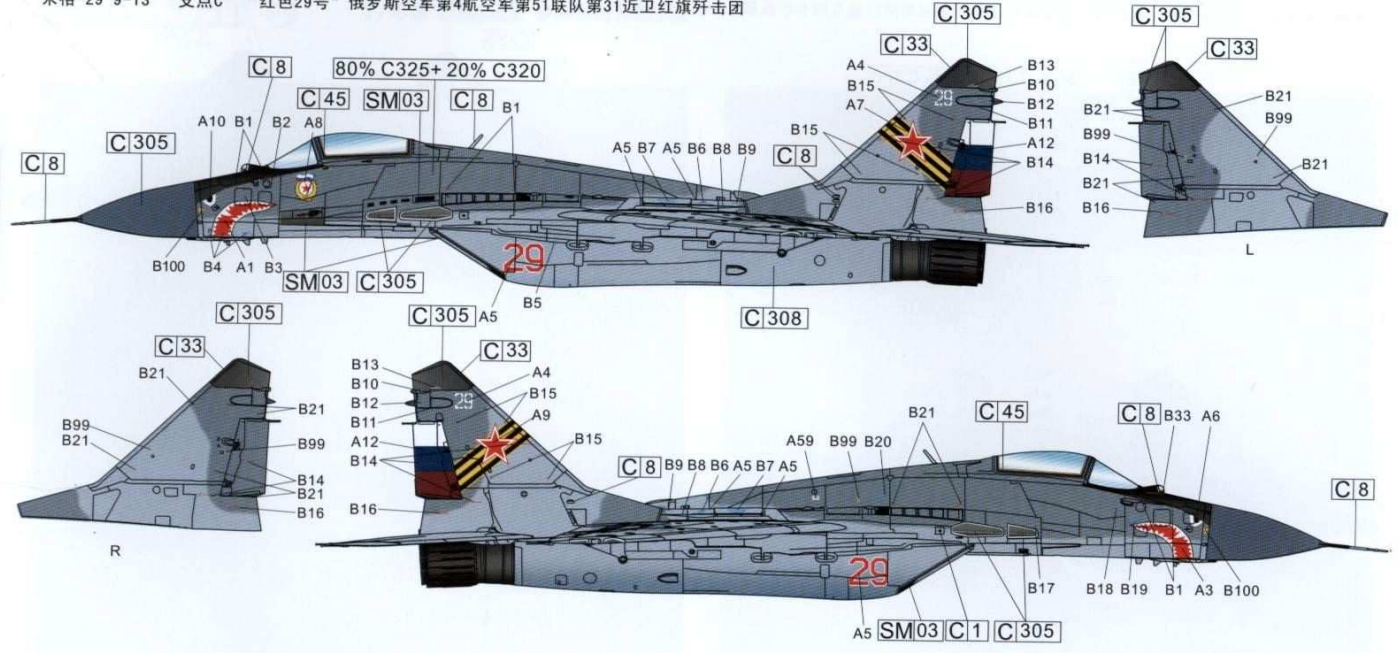

[4813] 1/48 MiG-29 9-13 "FULCRUM C" FIGHTER

MiG-29 9-13 "Fulcrum C" "White 51" 120th GvIAP, 21st OSAD, 14th Air Army, Russian Air Force
 米格-29 9-13 "支点C" "白色51号" 俄罗斯空军第14航空军第21独立综合联队第120近卫歼击团

