



Советский 6-колесный армейский автомобиль

Наиболее распространенный полноприводный 6-колесный грузовой автомобиль Советской Армии периода 80-х годов имел дизельный двигатель и компоновку с кабиной над двигателем. Его серийное производство началось в 1981 г. на заводе в г. Набережные Челны. Автомобиль отличался высокой надежностью и проходимостью по бездорожью. Базовая модель предназначалась, в первую очередь, для перевозки личного состава или груза до 6 т.

Автомобиль состоит на вооружении армий России, Украины и других стран.

На базе шасси 6-колесного бескапотного автомобиля строились многочисленные модификации как для армии, так и для народного хозяйства СССР. В 1989 г. появилась улучшенная модель 101, а в 1996 г. - 114. Ее производство на Камском автомобильном заводе продолжается в настоящее время.

Тактико-технические характеристики автомобиля модели 101

Грузоподъемность, т.....	6
Снаряженная масса, кг.....	2145
Длина, мм.....	7895
Ширина, мм.....	2500
Высота, мм.....	3200
База, мм.....	3340-1320
Колея передняя и задняя, мм.....	2010
Двигатель.....	740.20, 8-цил., 10,85 л., 220 л.с.
Максимальная скорость, км/ч.....	85
Запас хода по шоссе, км.....	830

ВНИМАНИЕ!

Перед сборкой внимательно прочитайте руководство по монтажу. Каждая деталь пронумерована. Соблюдать последовательность монтажа. Необходимые рабочие инструменты: нож и напильник для зачистки деталей; резиновая лента, клейкая лента и зажимы для сушки белия для приклеивания склеиваемых деталей. Детали из пластика очистить в растворе мягкого моющего средства и высушить на воздухе для того, чтобы краска и переводные картинки лучше прилипали. Перед приклеиванием проверить, подходят ли детали, клей наносить экономно. Хром и краску удалить с поверхностей склеивания. Небольшие детали покрасить перед тем, как они будут удалены из рамок. Краску необходимо хорошо просушить, только после этого продолжать сборку. Каждую соответствующую переводную картинку отдельно вырезать и примерно на 20 секунд окунуть в теплую воду. На обозначенном месте картинку отделить от бумаги и прижать промокающей бумагой.

Soviet Six-Wheel Army Truck

The most common all-wheel drive 6-wheel Soviet Army truck of 80s had a diesel engine and the layout of cab-over-engine. Its production began in 1981 at the plant in Naberezhnye Chelny. The car featured a high reliability and all-road abilities.

The base model was designed primarily for the transportation of personnel and cargo up to 6 tons.

The car is now in service with the armies of Russia, Ukraine and other countries.

There were many 6-wheel cabover truck modifications for Soviet Army and civilian use. In 1989 it was released an improved model 101, and in 1996 - model 114. Its production at the Kama Automobile Plant is currently ongoing.

Tactical and Technical Specifications of model 101 truck

Full load, t.....	6
Empty weight, kg.....	8745
Length, mm.....	7895
Width, mm.....	2500
Height, mm.....	3200
Wheel base, mm.....	3340+1320
Track front & rear, mm.....	2010
Engine.....	740.20, 8 cyl., 10,85 l., 220 hp
Max. Speed, km/h.....	85
Range, km.....	830

CAUTION!

Read the instructions thoroughly prior to assembly. Each component is numbered. Adhere to specified sequence of assembly. Tools required: knife and file for removal of components from frame; rubber bond, adhesive tape and clothes pegs for clamping components together after applying adhesive. Clean plastic components in a mild detergent solution and allow to air-dry so that paint and transfers adhere better. Prior to applying adhesive, check to see whether the components fit together; apply adhesive sparingly. Remove chrome and paint from the contact surfaces. Paint small components before removing them from the frame. Allow paint to dry well, and only then continue to assemble. Cut out each transfer individually and immerse in warm water for approx. 20 seconds. Slide transfer off paper and into designated position, then press on with blotting paper.

ИСПОЛЪЗУЕМЫЕ КРАСКИ / USED COLORS:

	Revell	Tamiya		
A	361	XF62	Оливково-зеленый, полуматовый	Olive Green
B	302	X18	Черный, полуматовый	Semigloss Black
C	108	XF1	Черный, матовый	Flat Black
D	199	XF16	Алюминий, полуматовый	Aluminium
E	183	XF64	Ржавчина	Rust

	Revell	Tamiya		
F	190	X11	Серебристый	Chrome Silver
G	731	X27	Красный, прозрачный	Clear Red
H	730	X26	Оранжевый, прозрачный	Clear Orange
J	191	X32	Сталь	Steel
K	105	XF2	Белый, матовый	Flat White
L	157	XF20	Серый, матовый	Grey

01 СТАДИЯ СБОРКИ
ASSEMBLY STEP

□ ПРИ СБОРКЕ НЕ ИСПОЛЪЗУЕТСЯ
PARTS NOT FOR USE

x2 СДЕЛАТЬ ДВЕ ДЕТАЛИ
MAKE 2 PCS

03 СБОРОЧНАЯ ЕДИНИЦА
ASSEMBLY UNIT

? ПРОИЗВОЛЬНЫЙ ВЫБОР
OPTIONAL

✂ ОТРЕЗАТЬ
CUT OFF

A ИСПОЛЪЗУЕМАЯ КРАСКА
USED COLOR

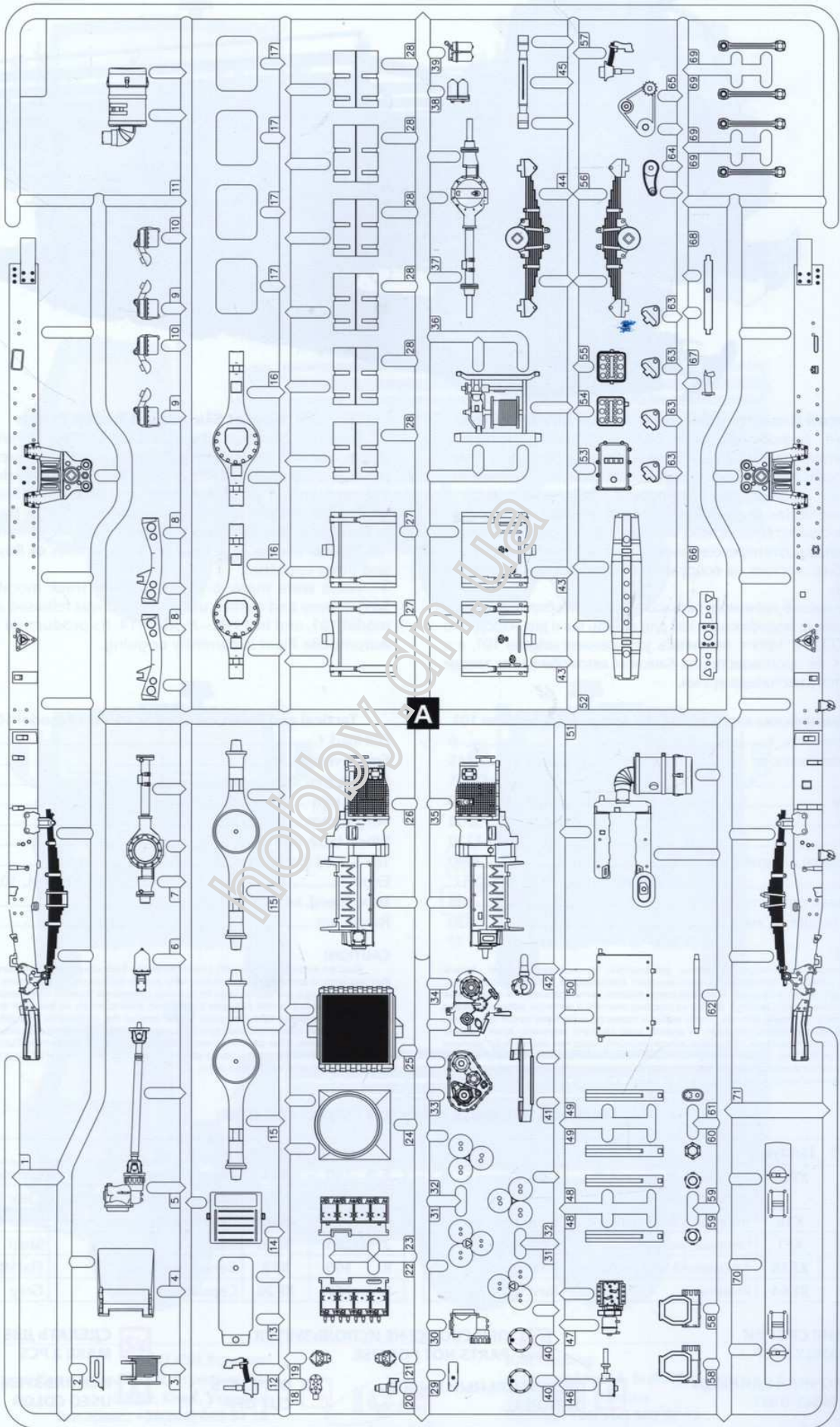

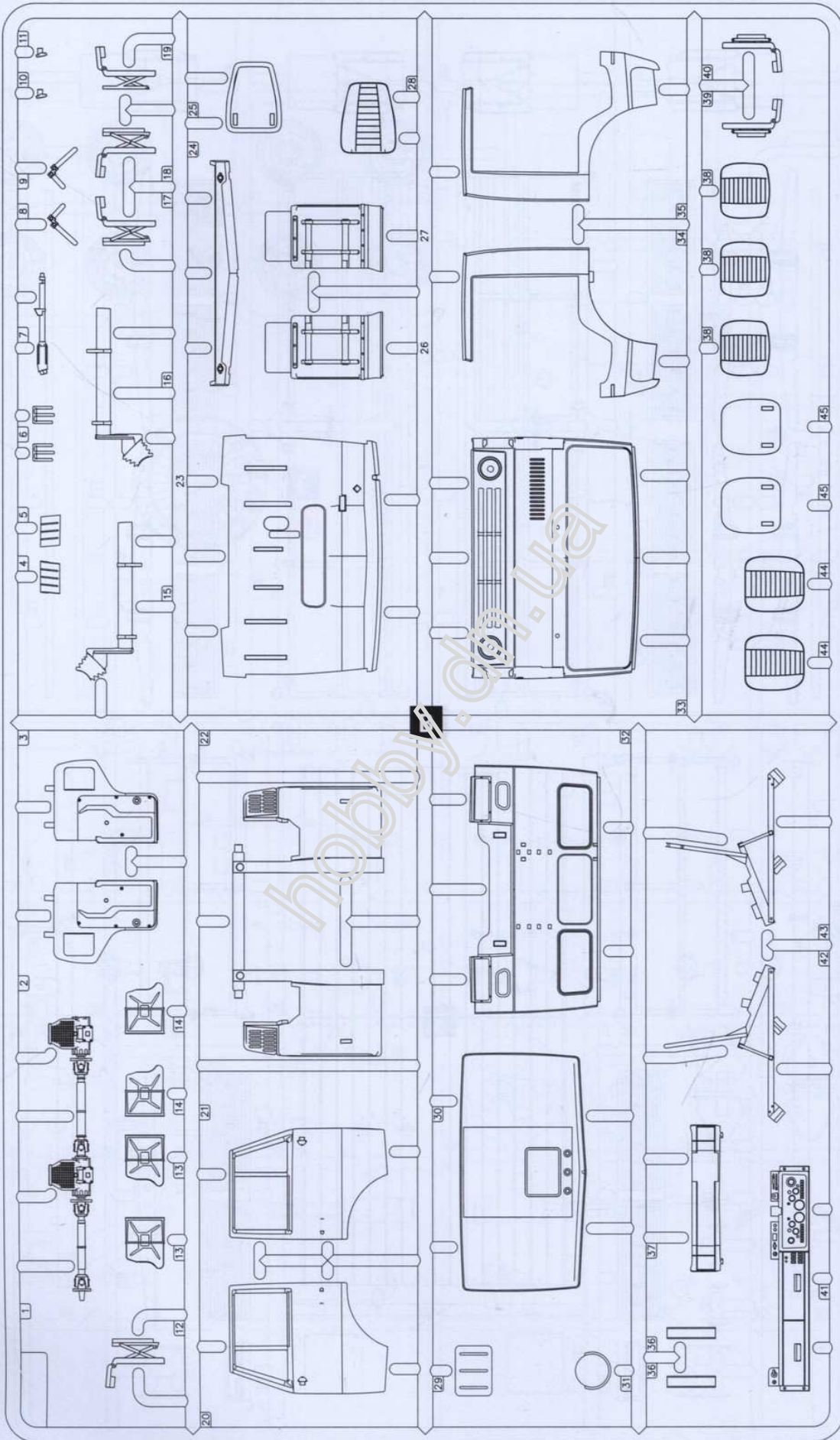

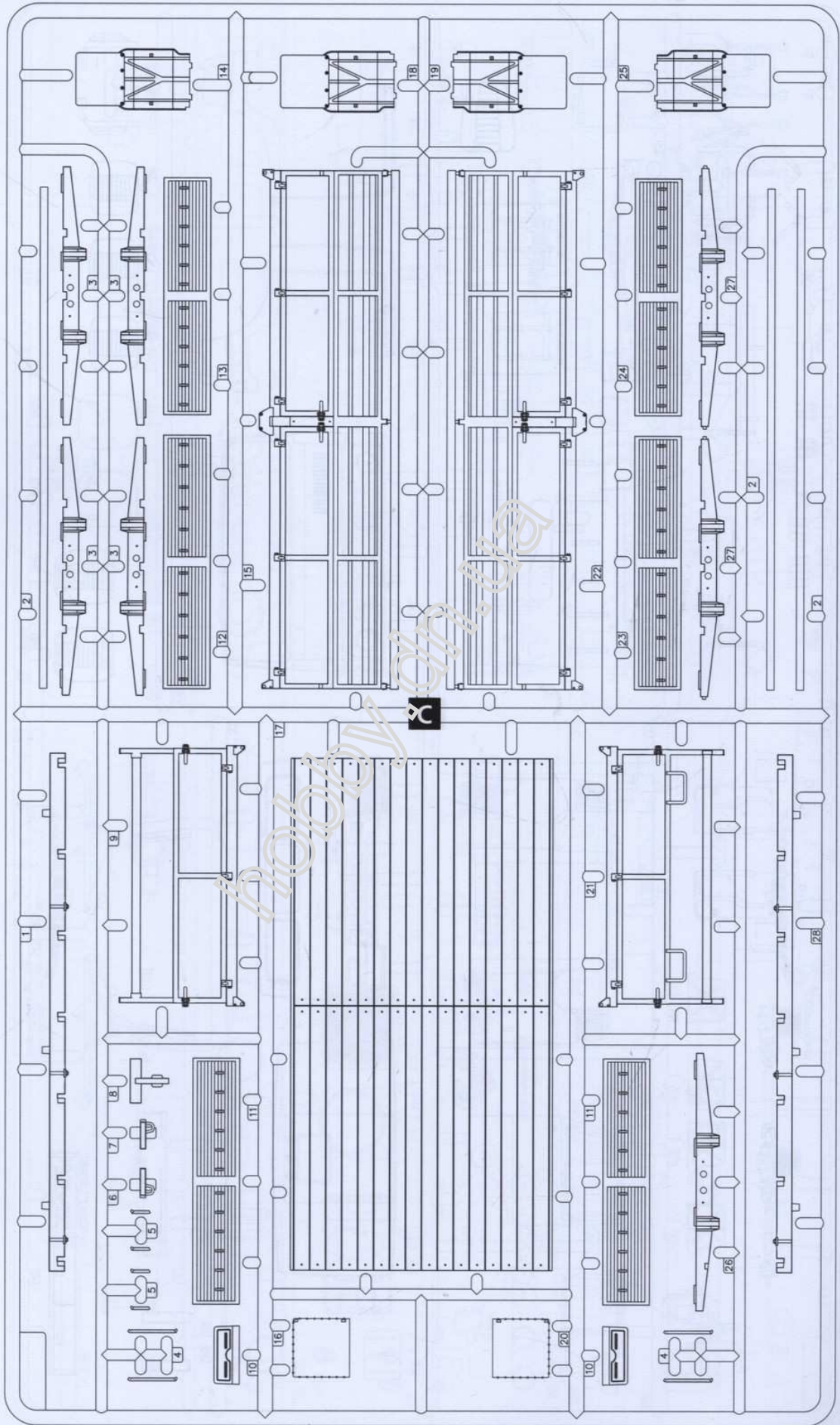

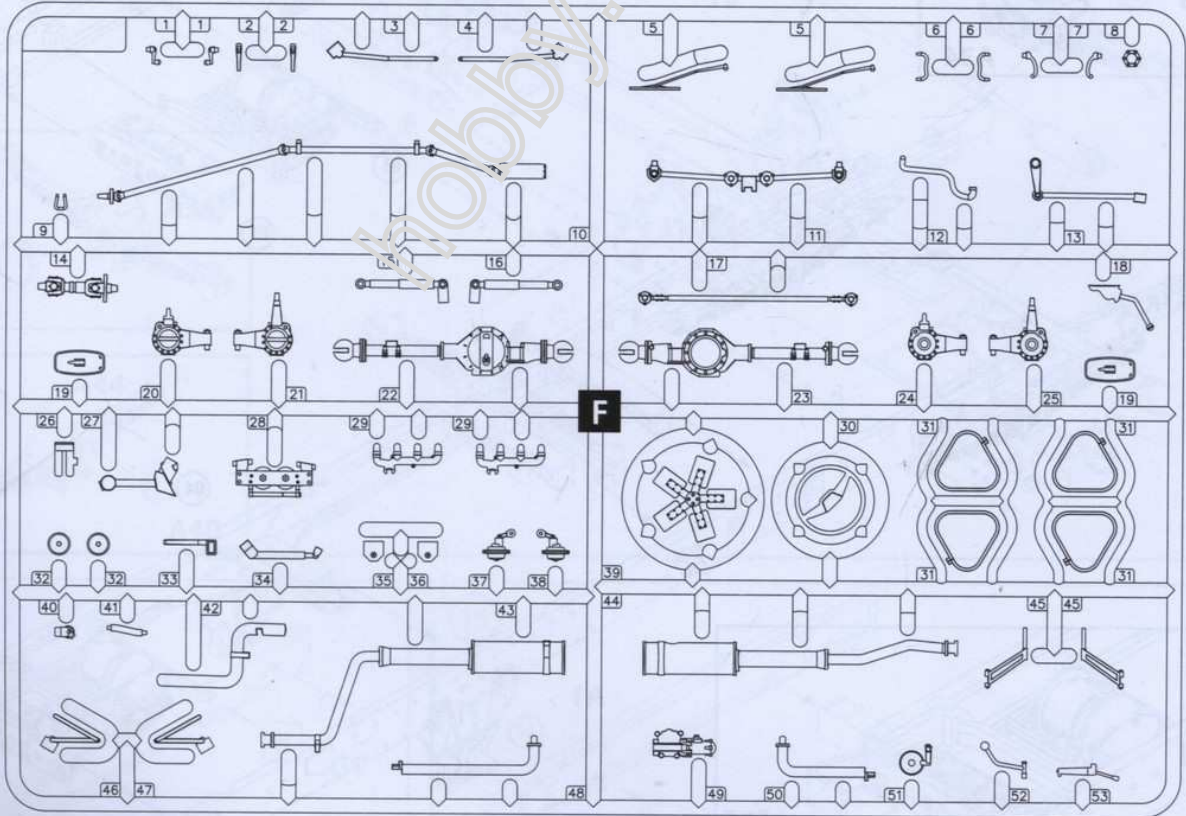
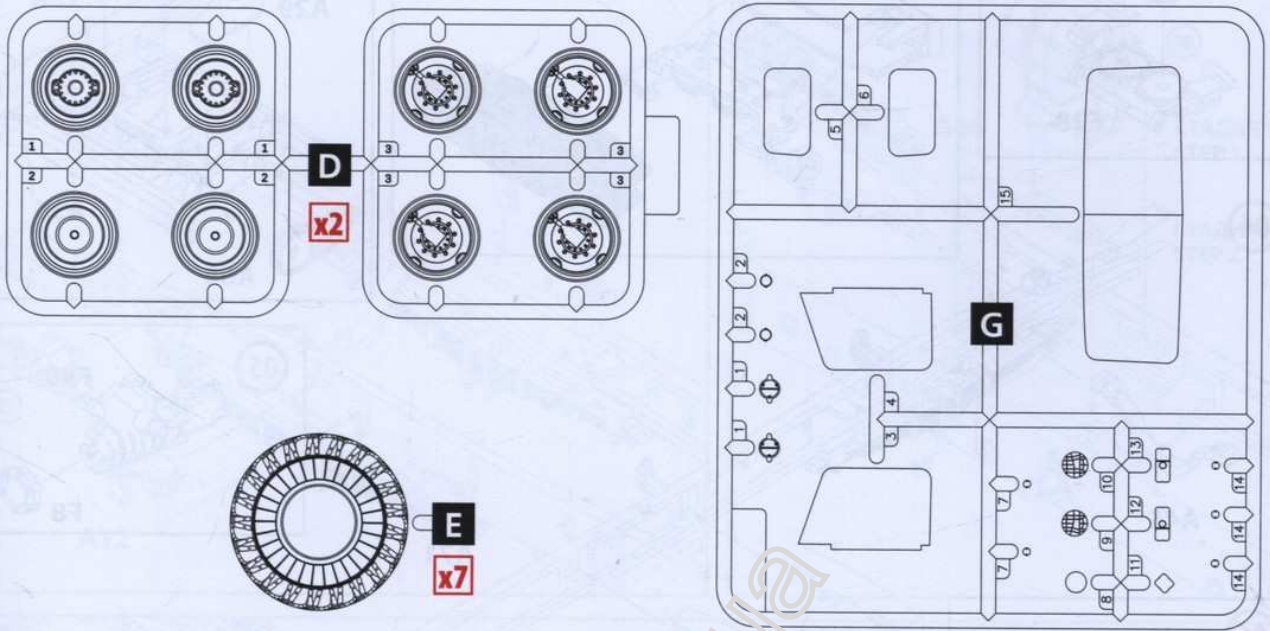

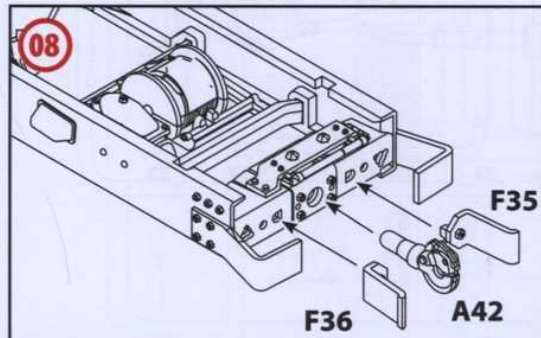
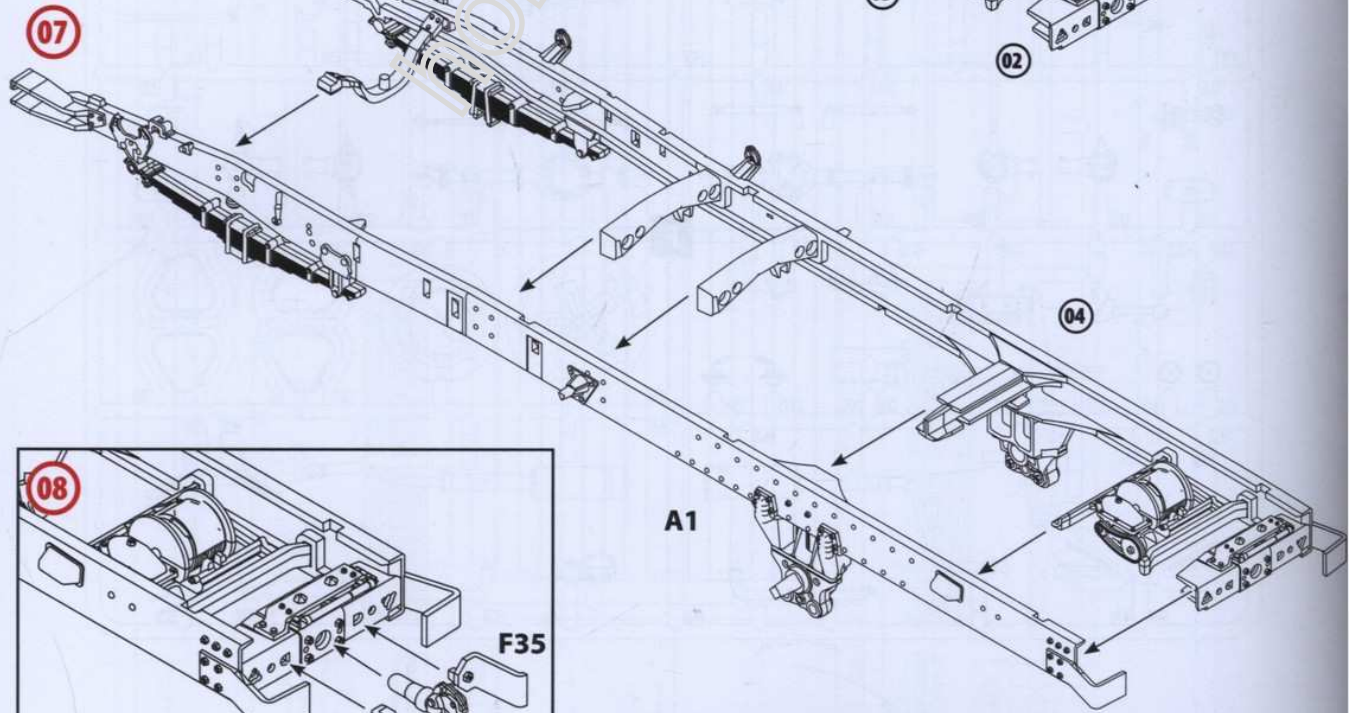
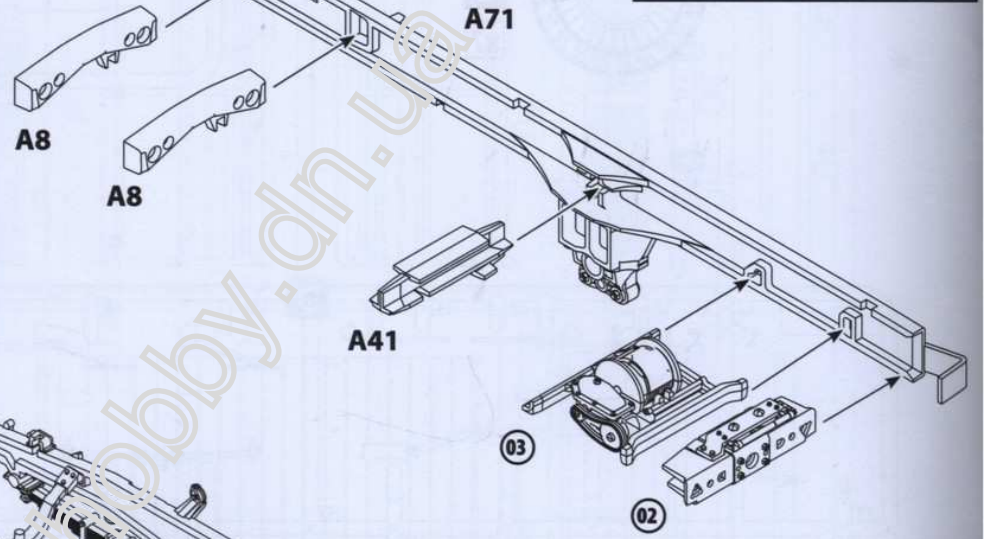
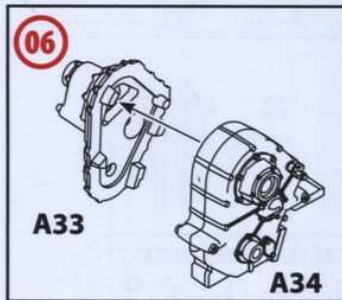
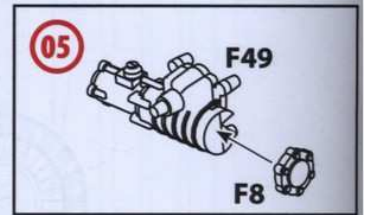
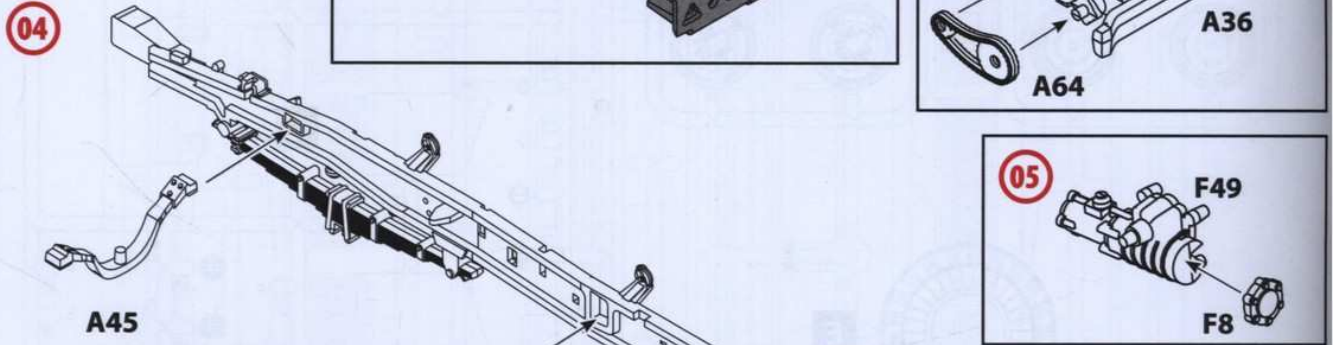
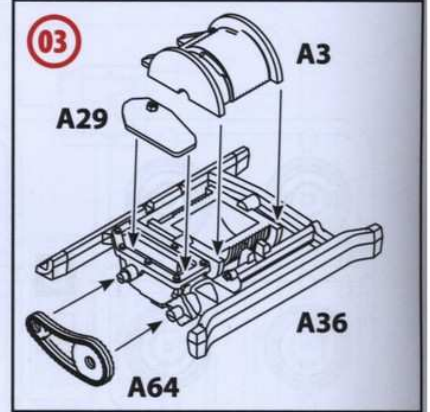
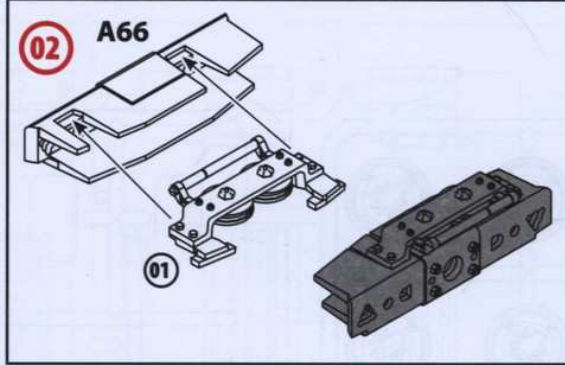
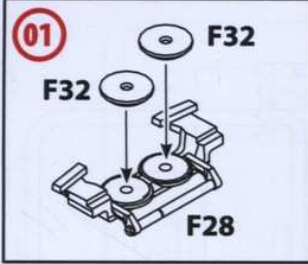

B ВСЕ ДЕТАЛИ ШАССИ, КРОМЕ ОБОЗНАЧЕННЫХ ОТДЕЛЬНО
 ALL CHASSIS DETAILS EXCEPT MARKED SEPARATLY

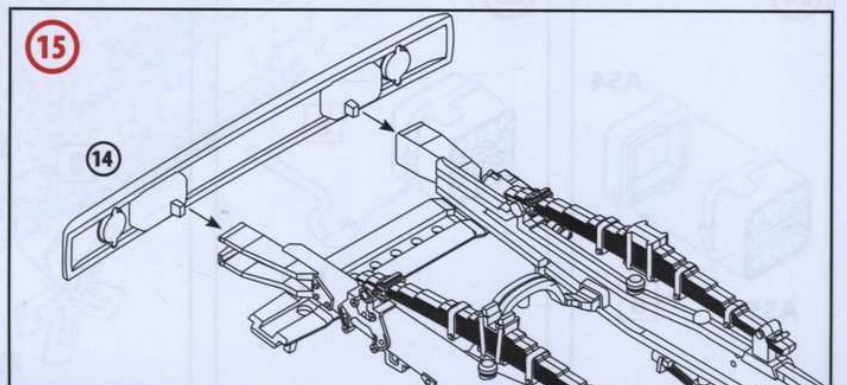
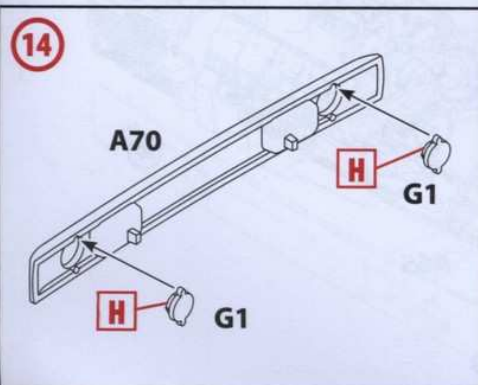
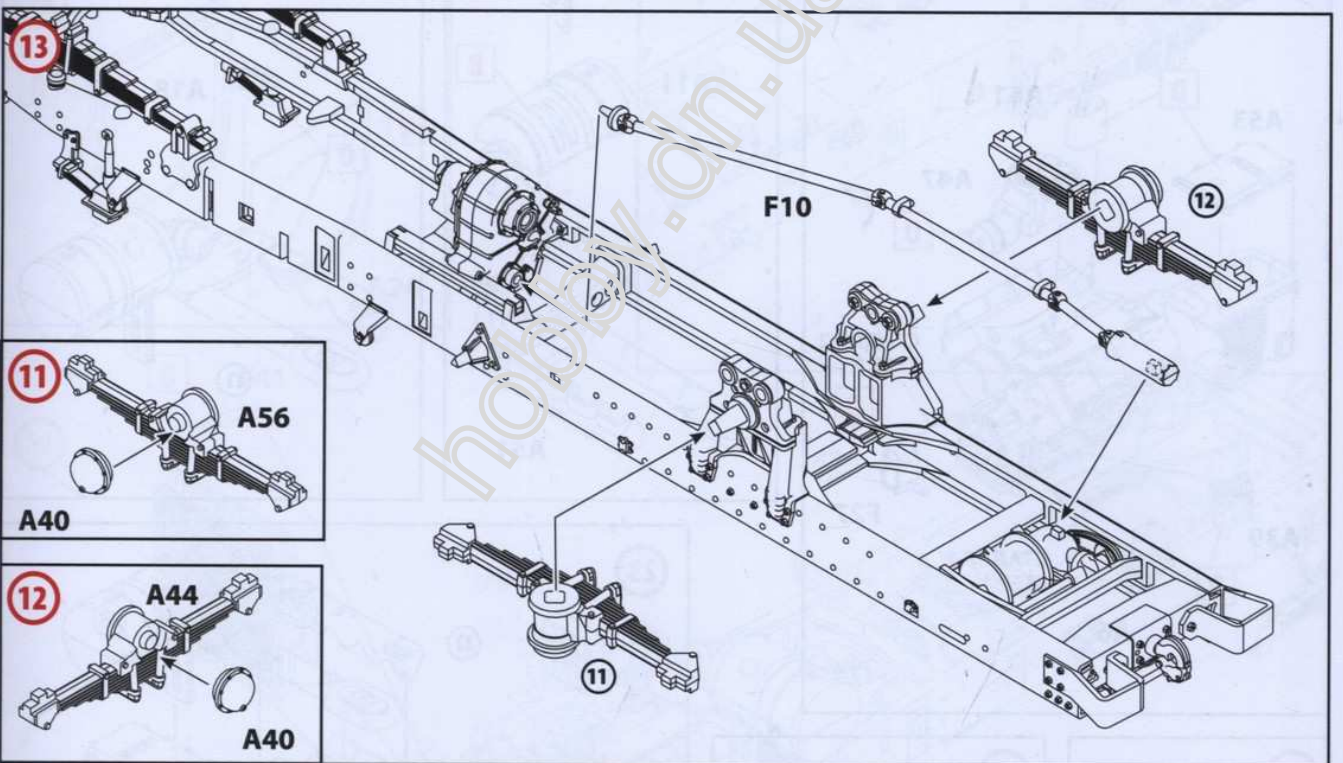
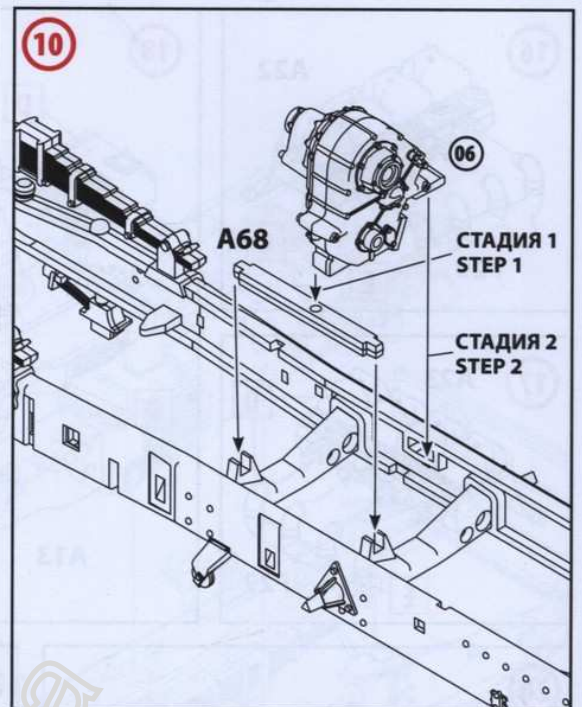
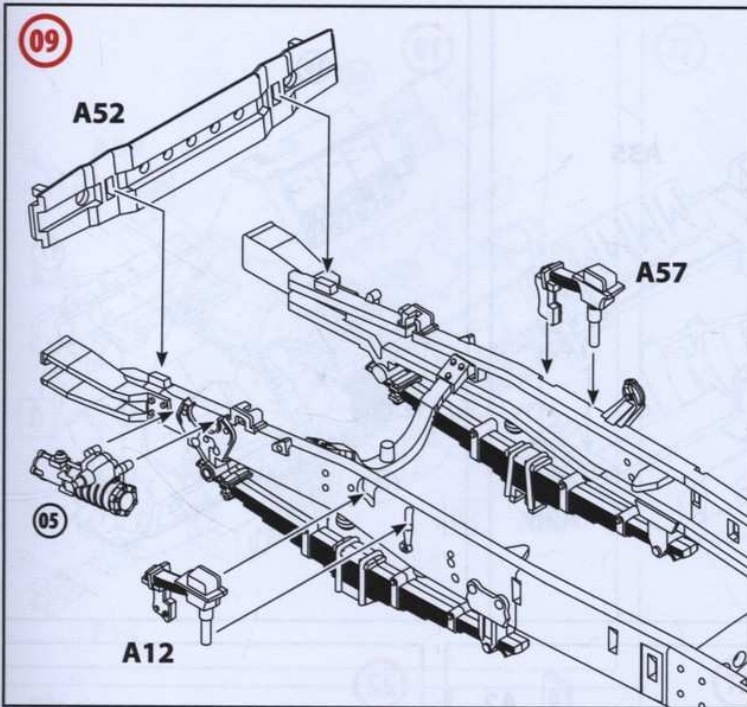

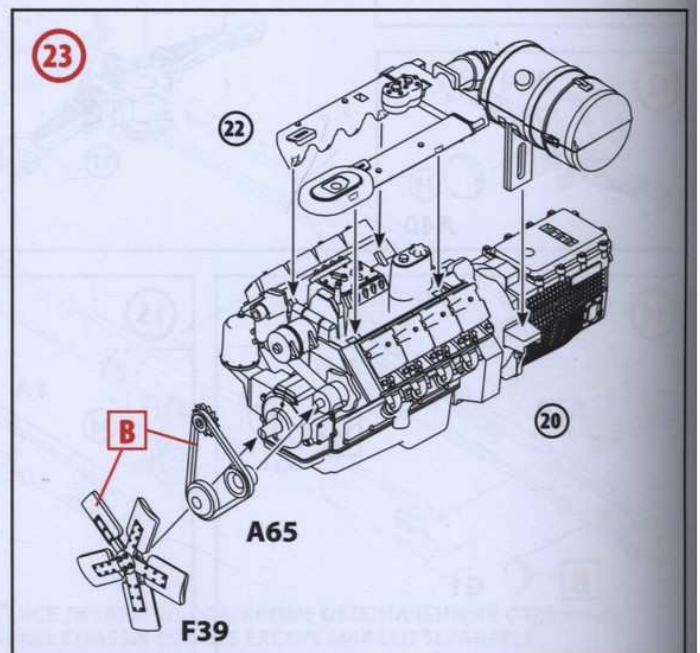
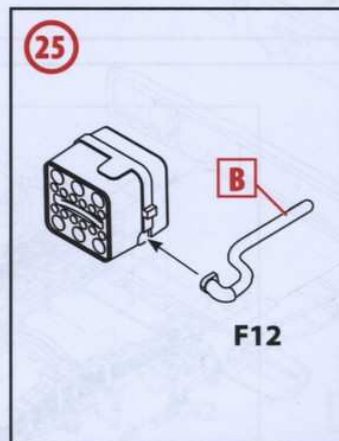
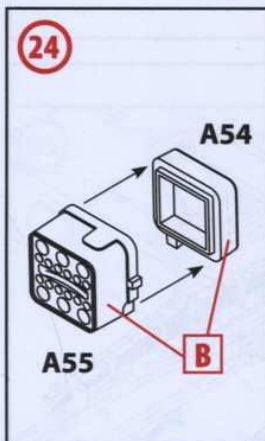
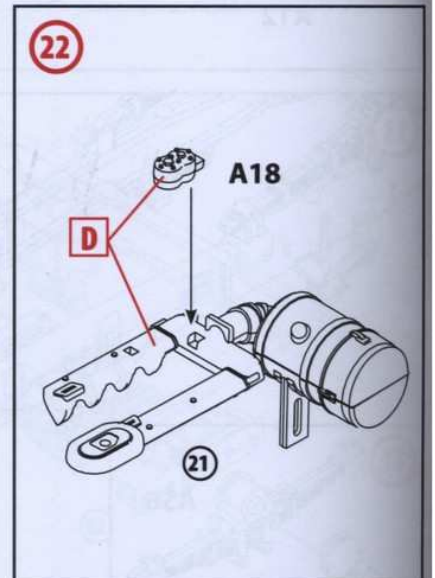
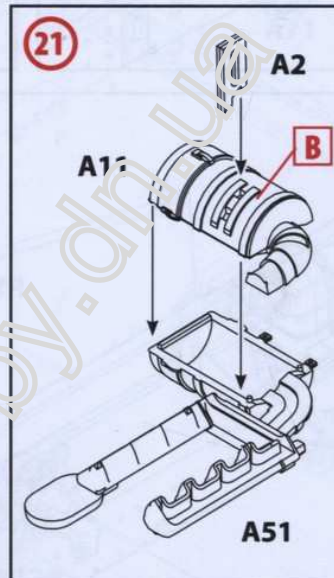
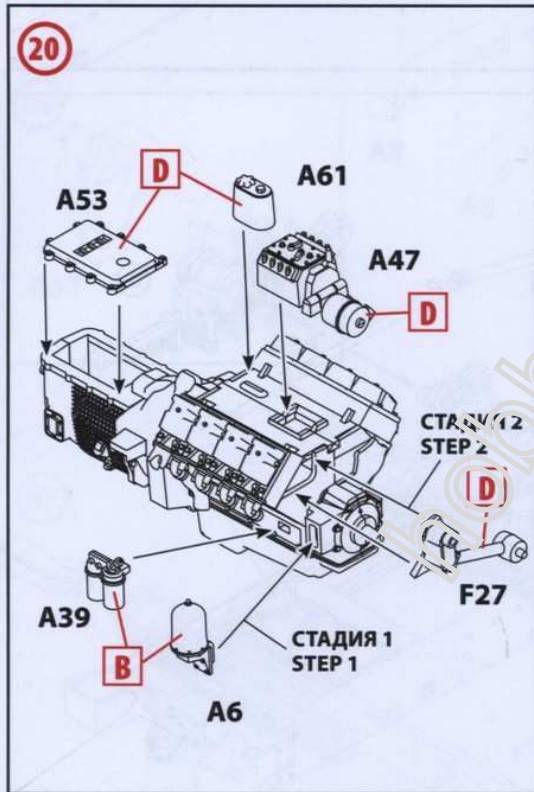
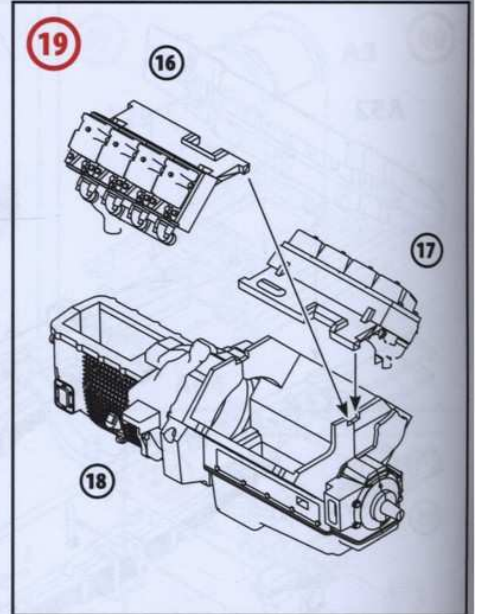
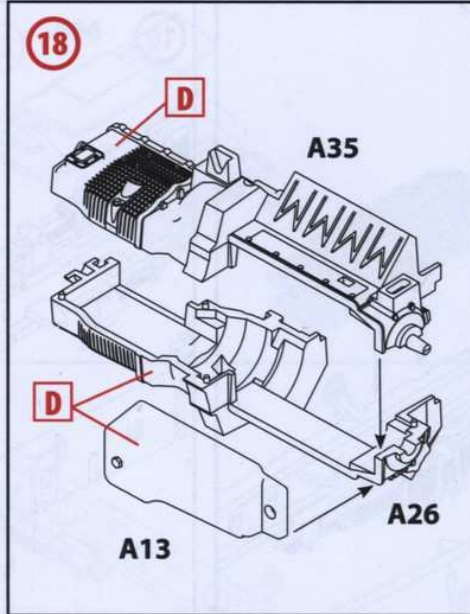
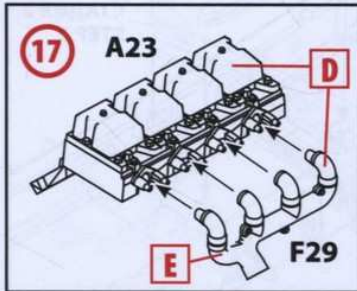
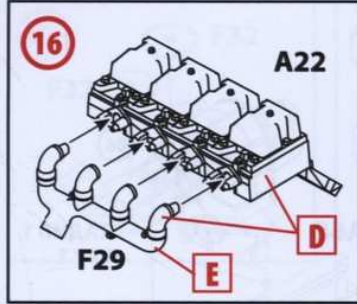

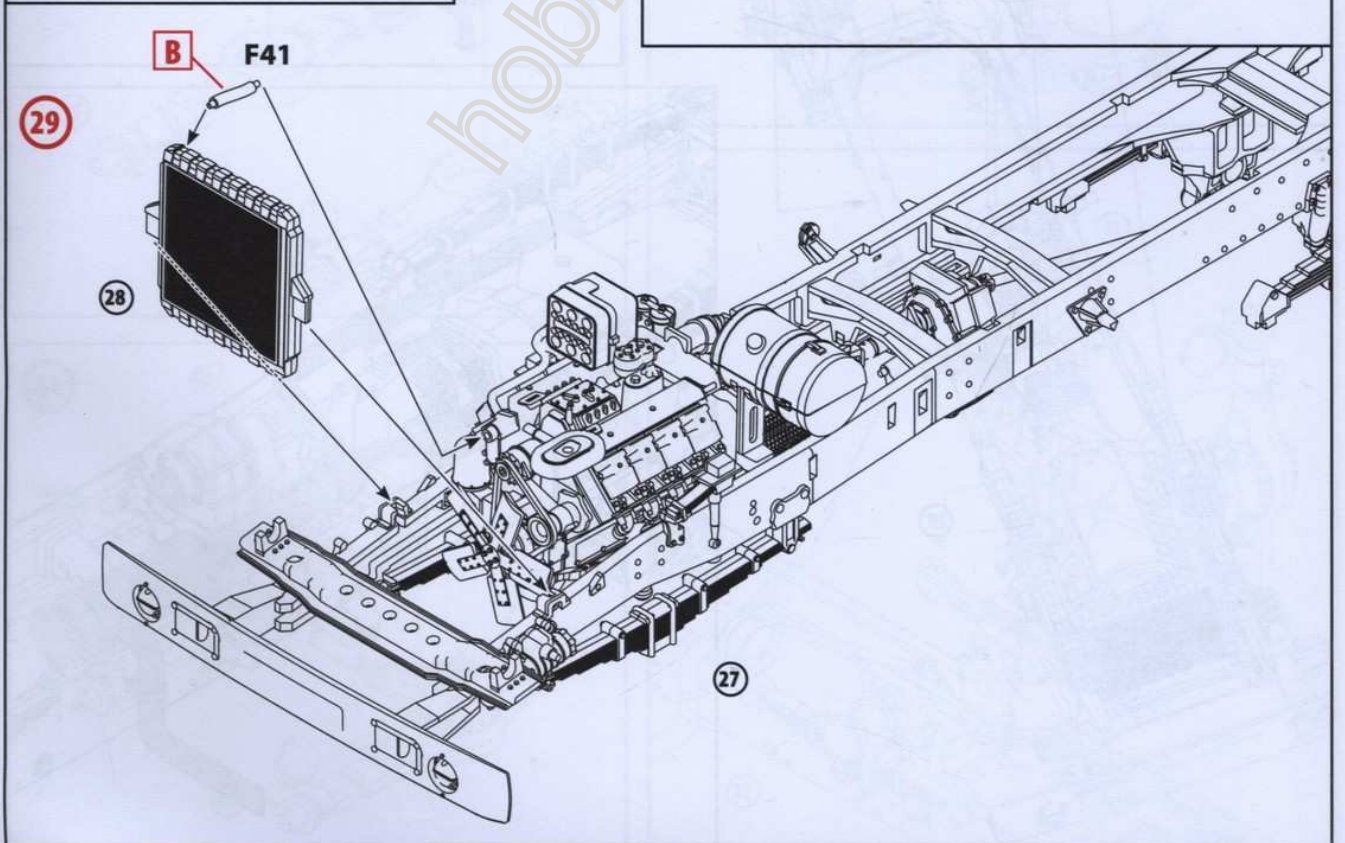
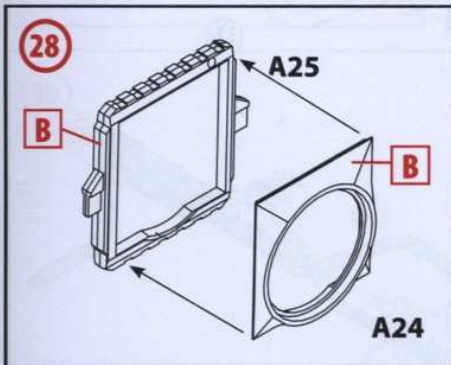
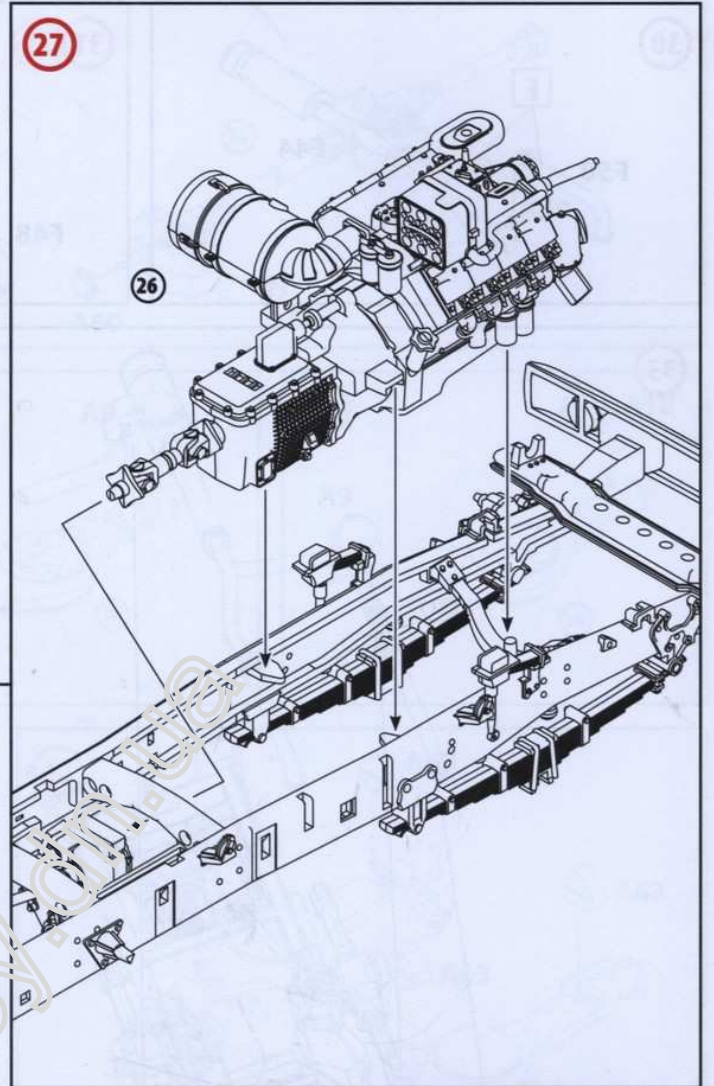
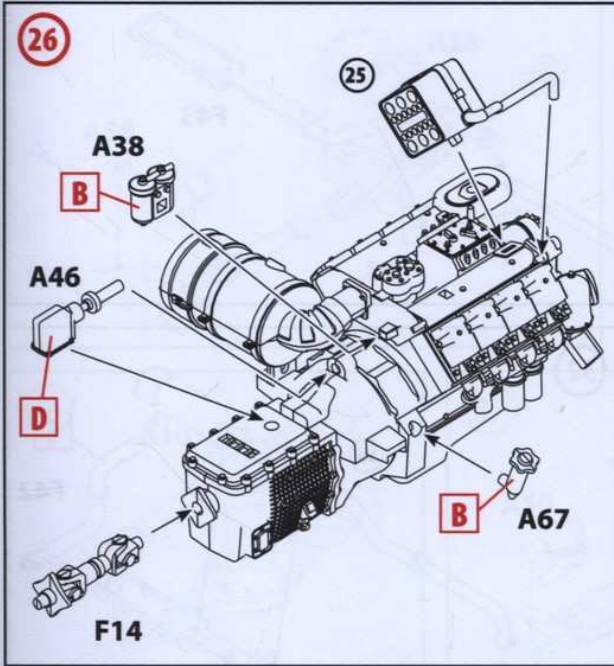

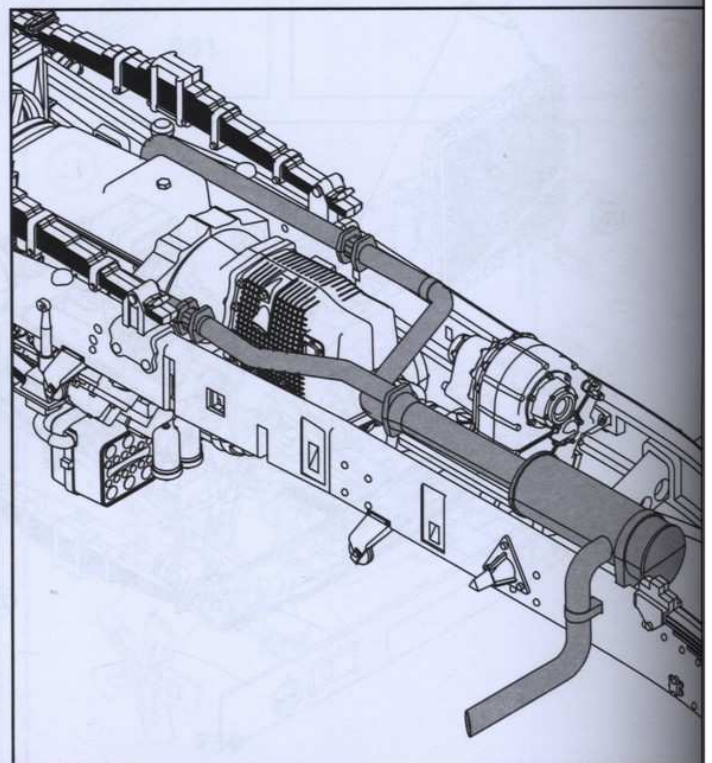
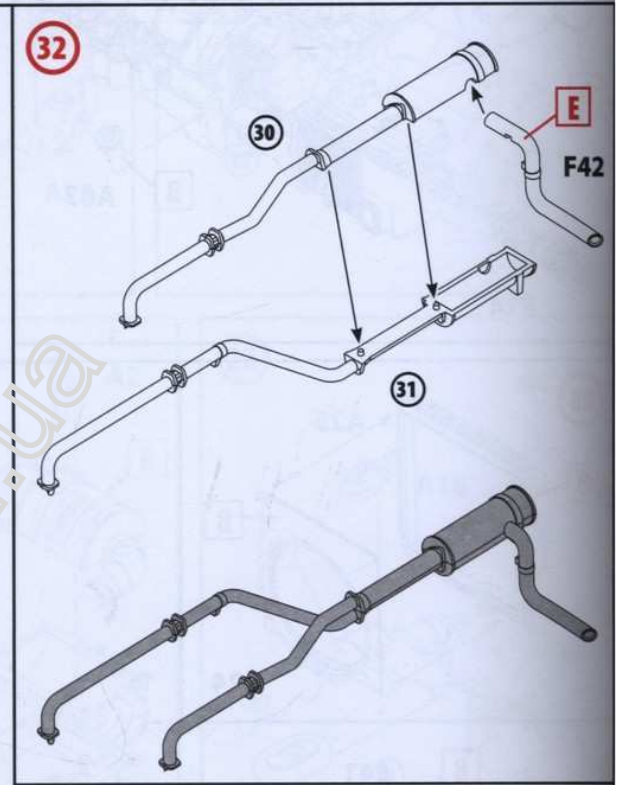
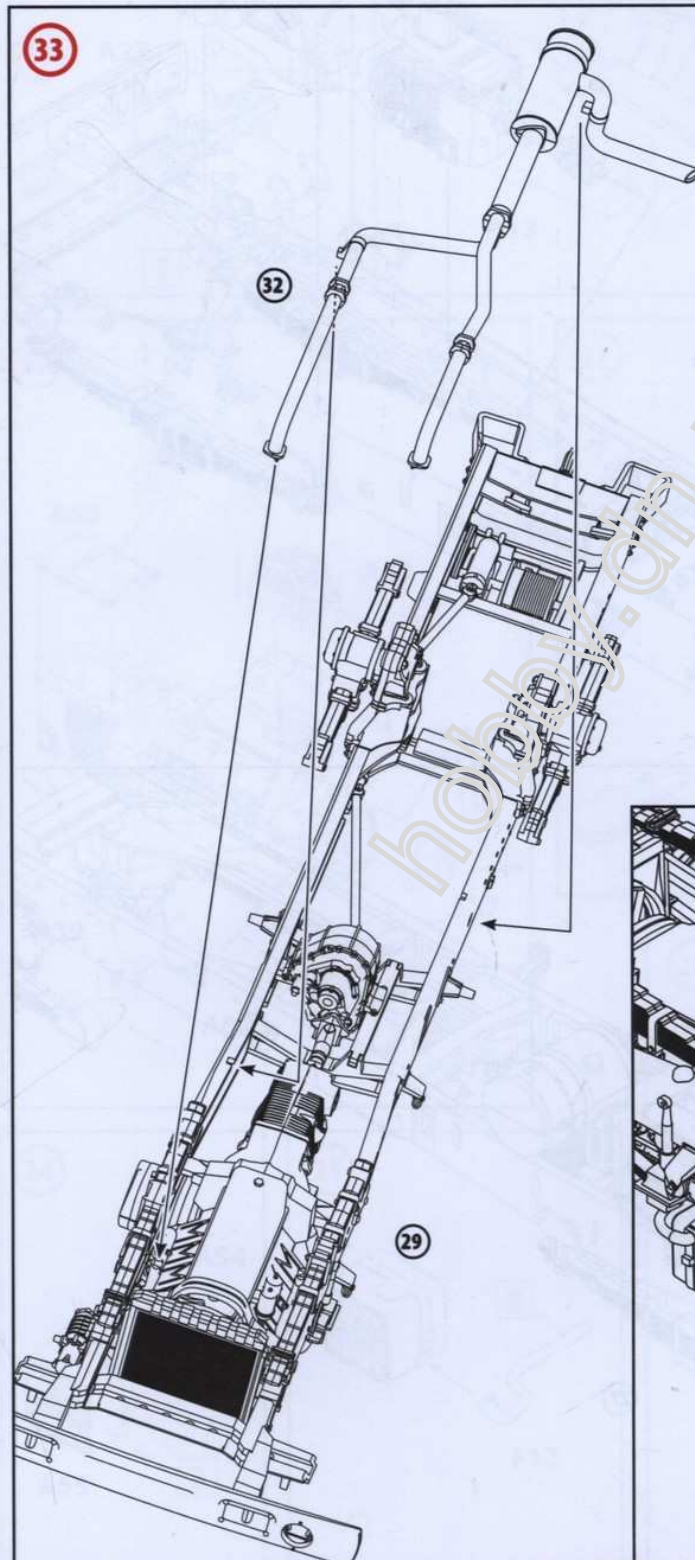
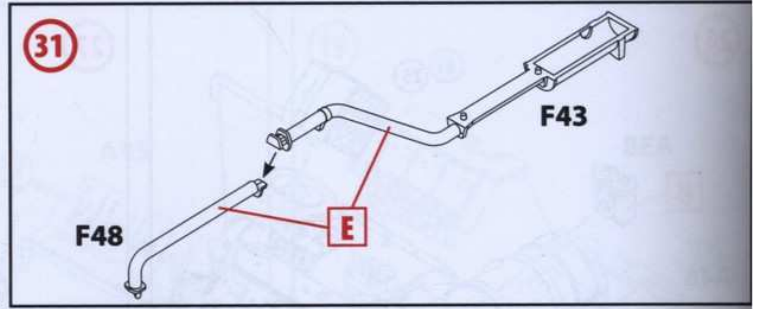
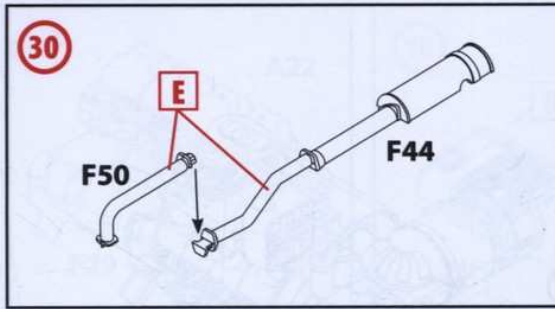

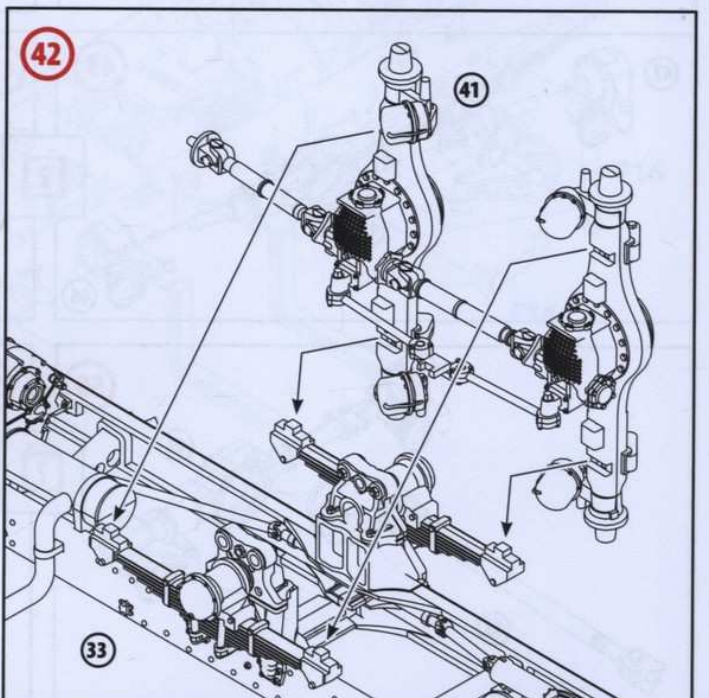
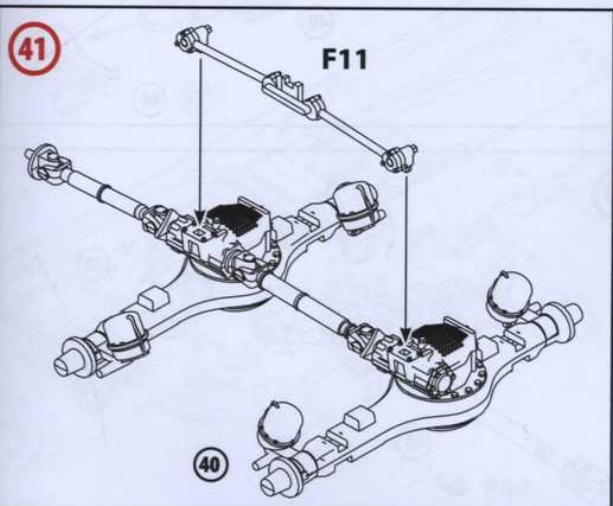
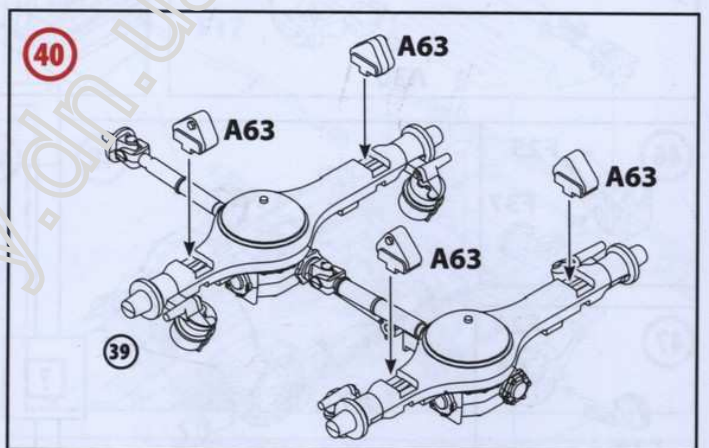
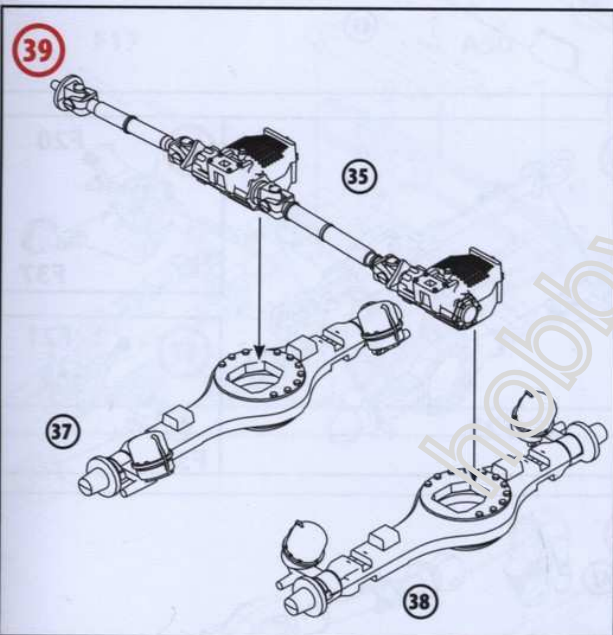
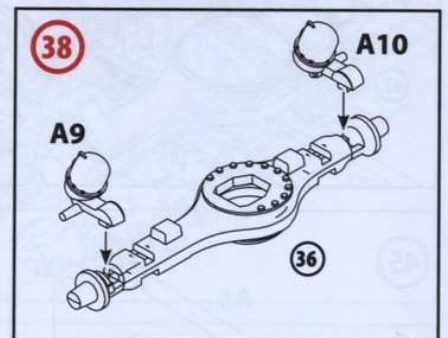
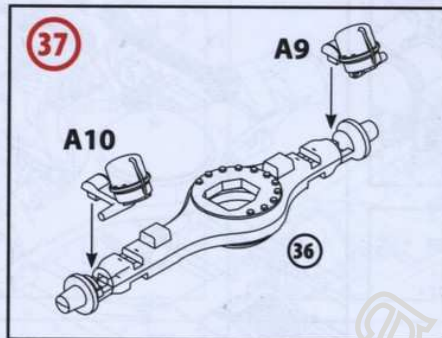
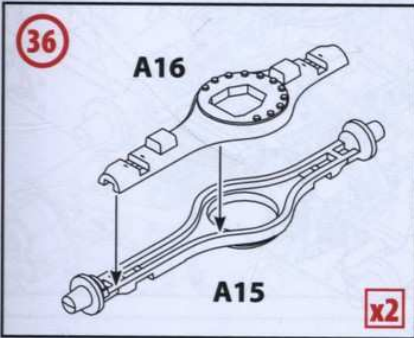
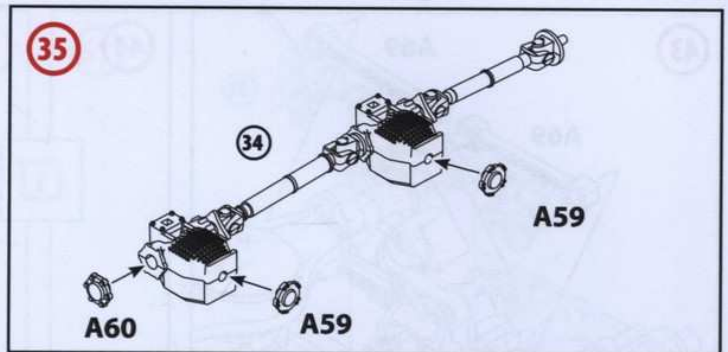
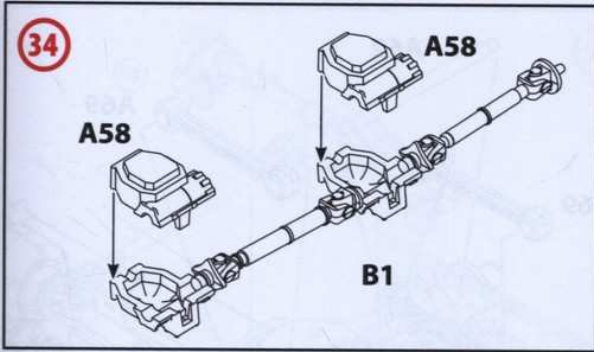

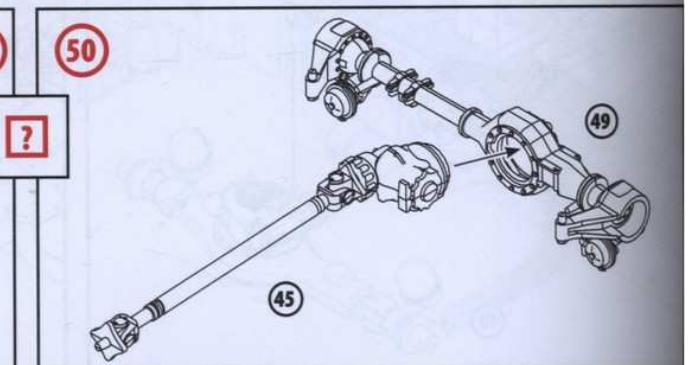
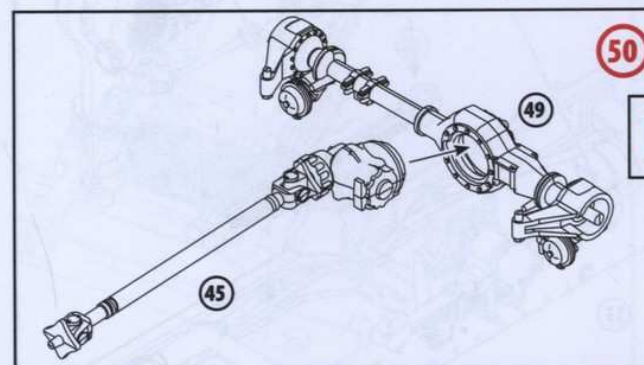
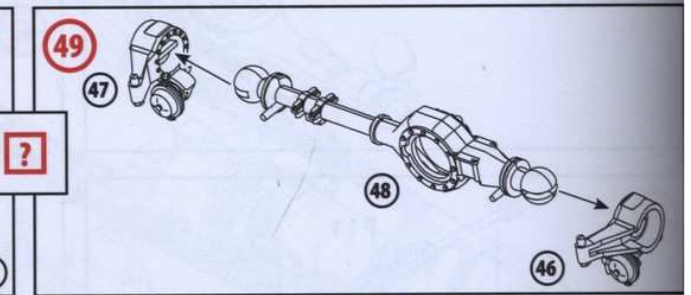
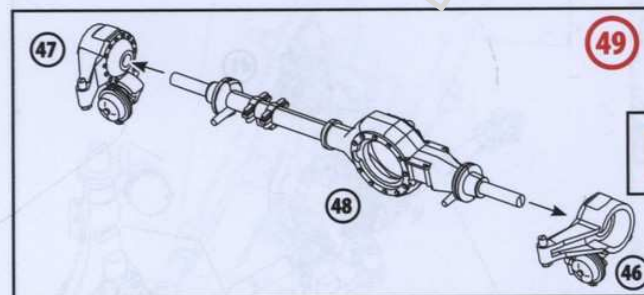
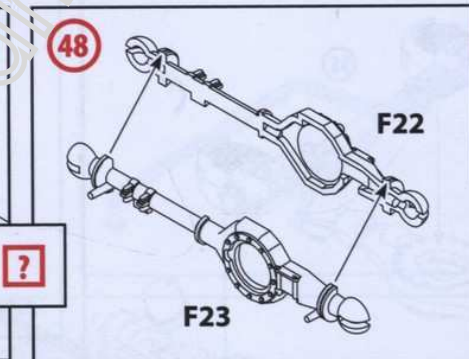
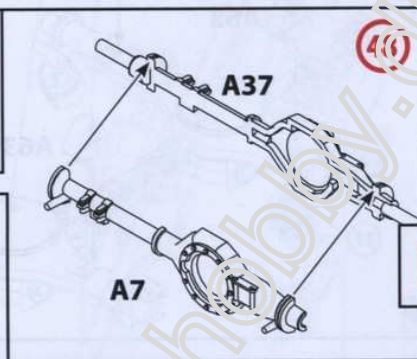
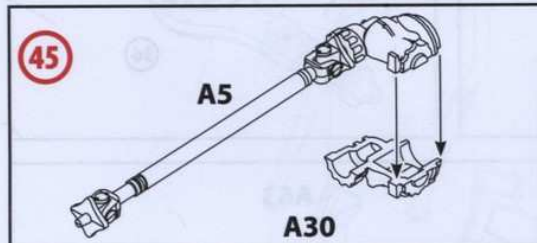
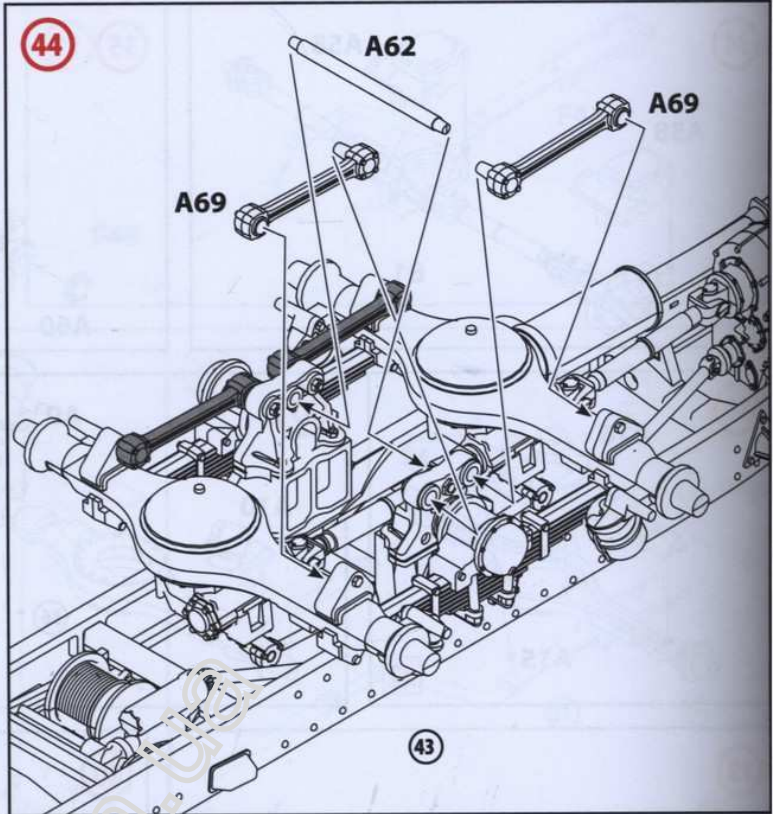
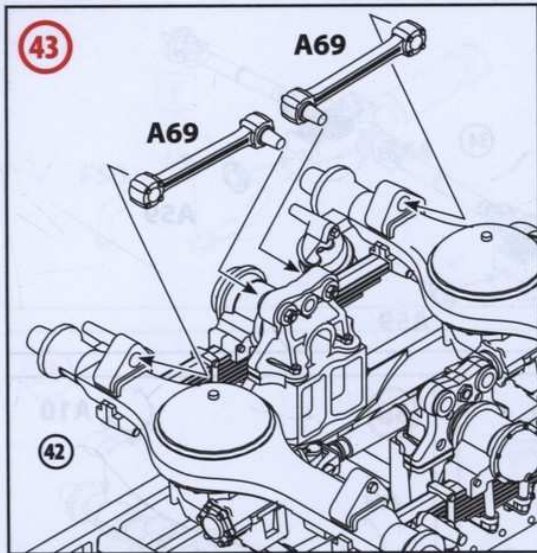

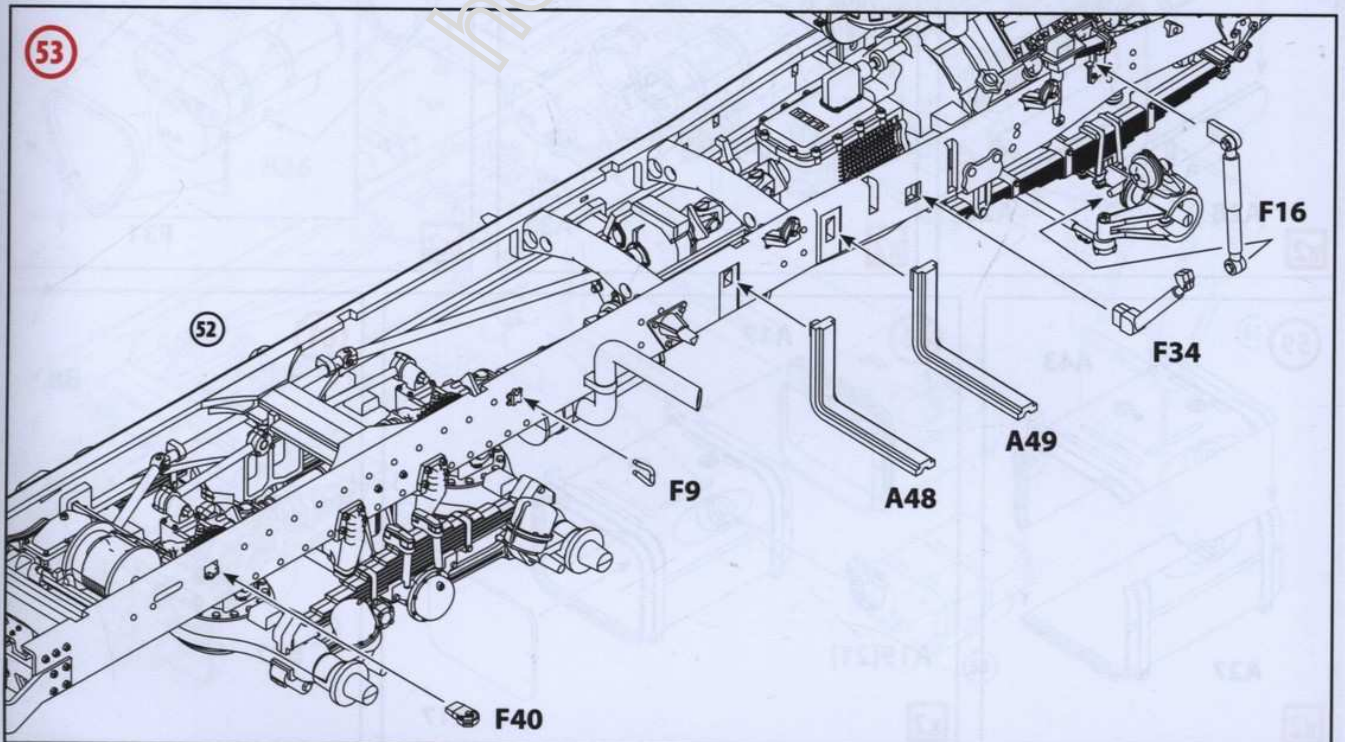
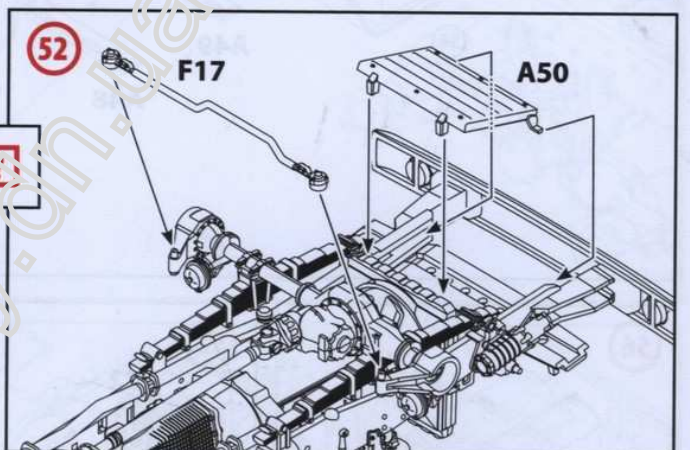
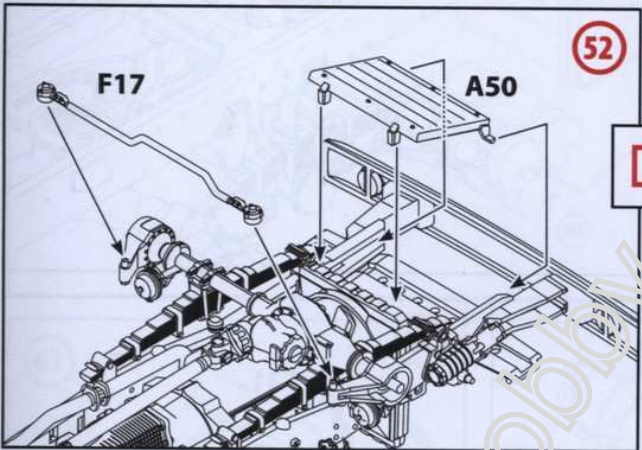
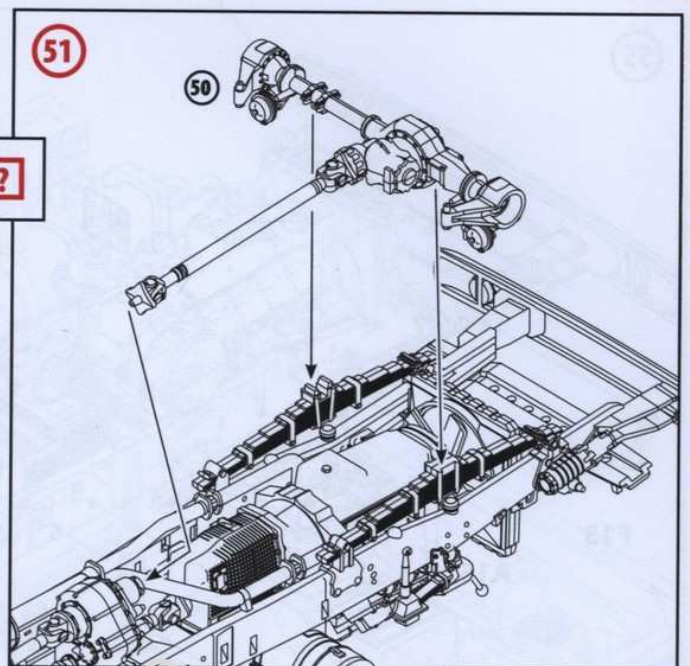
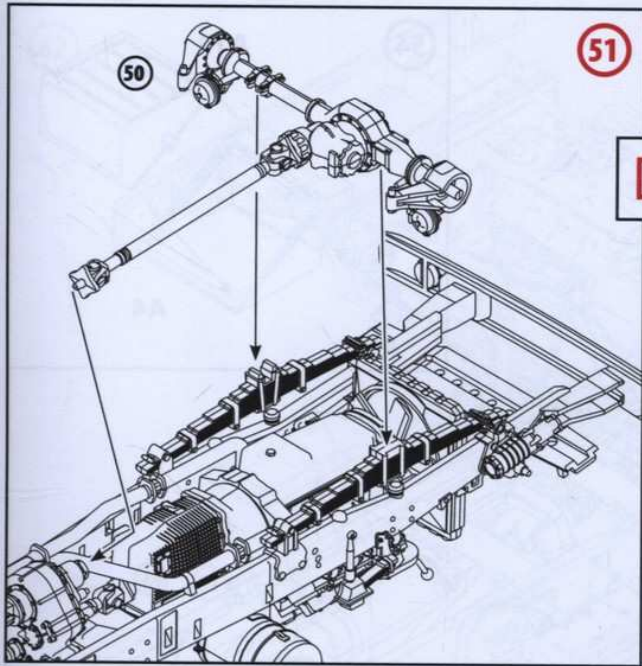

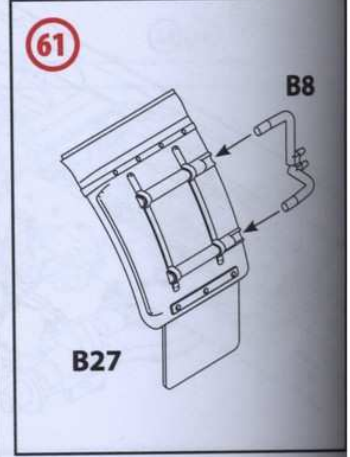
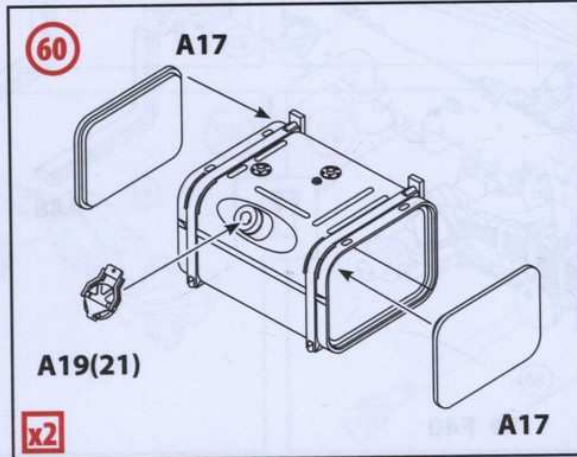
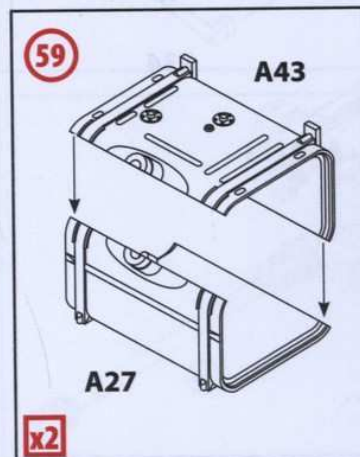
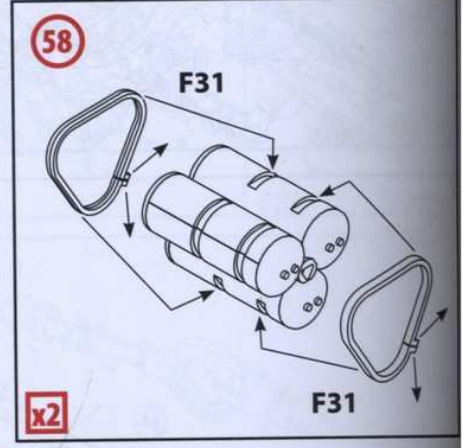
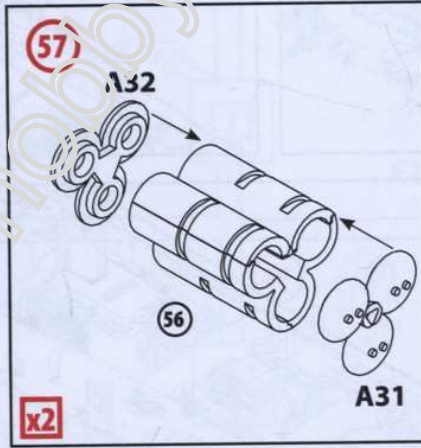
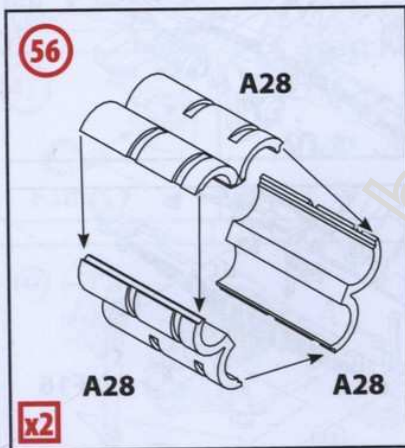
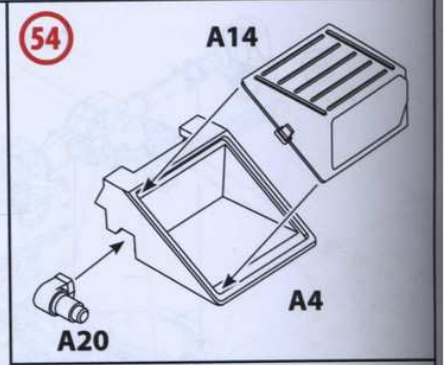
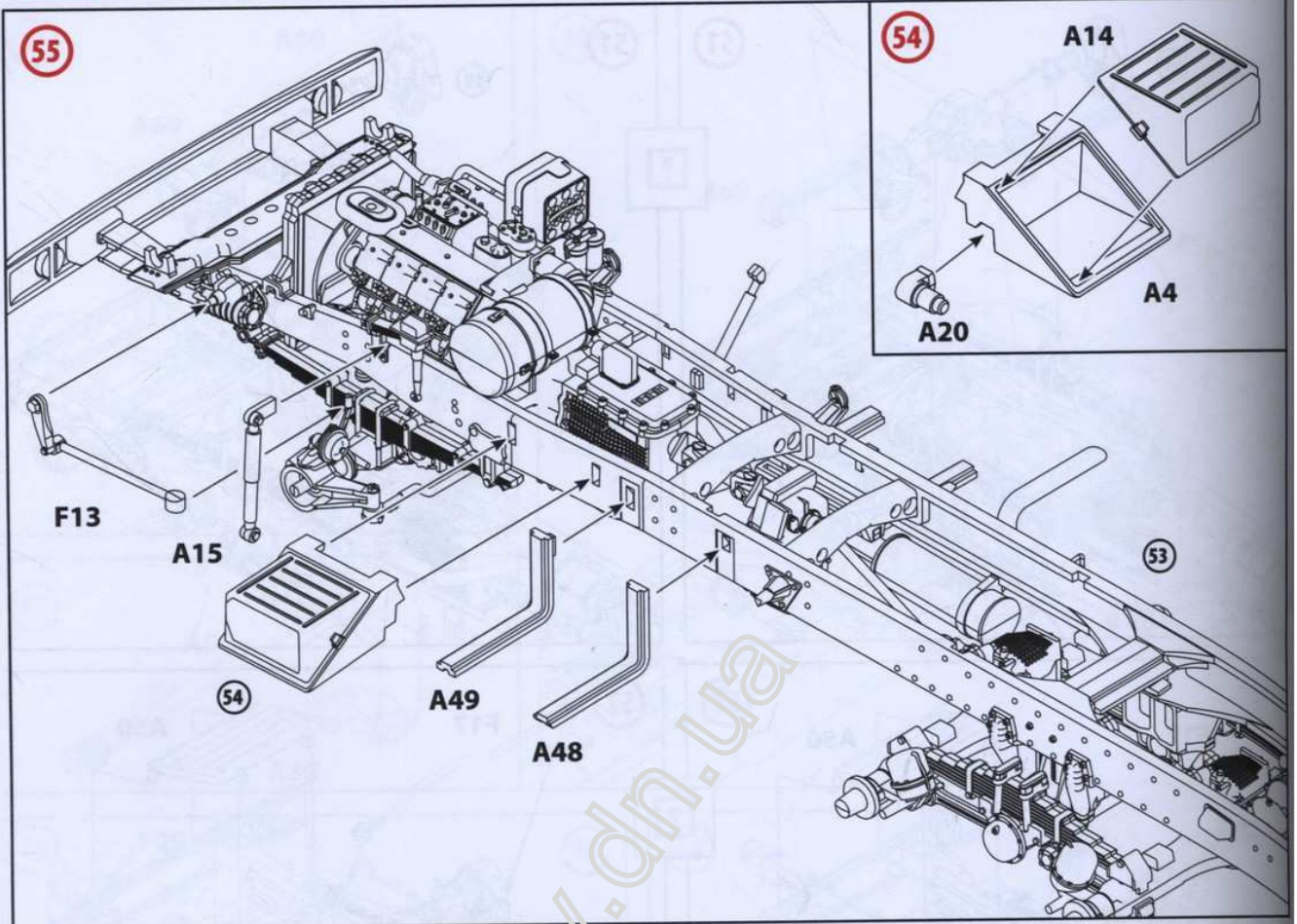

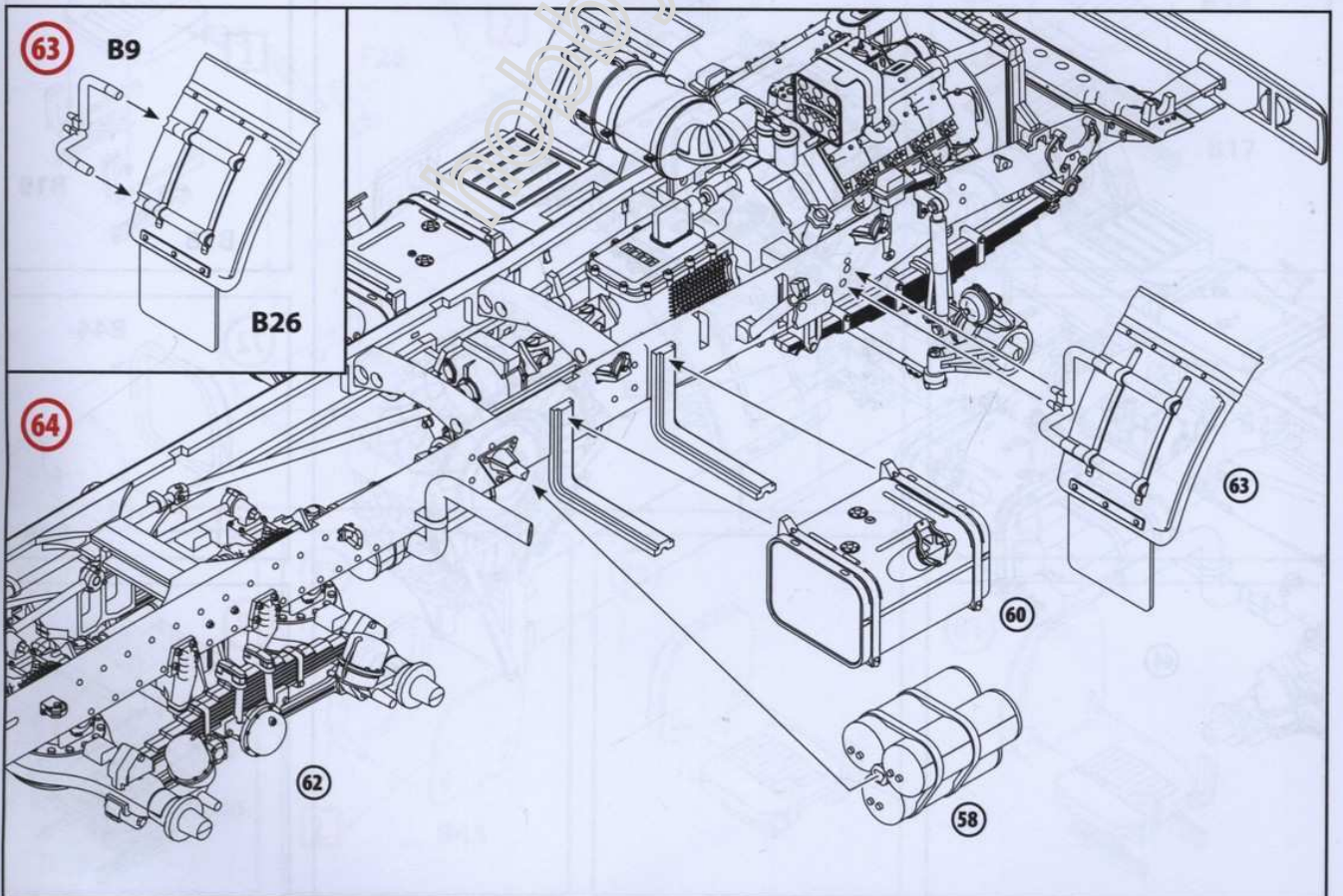
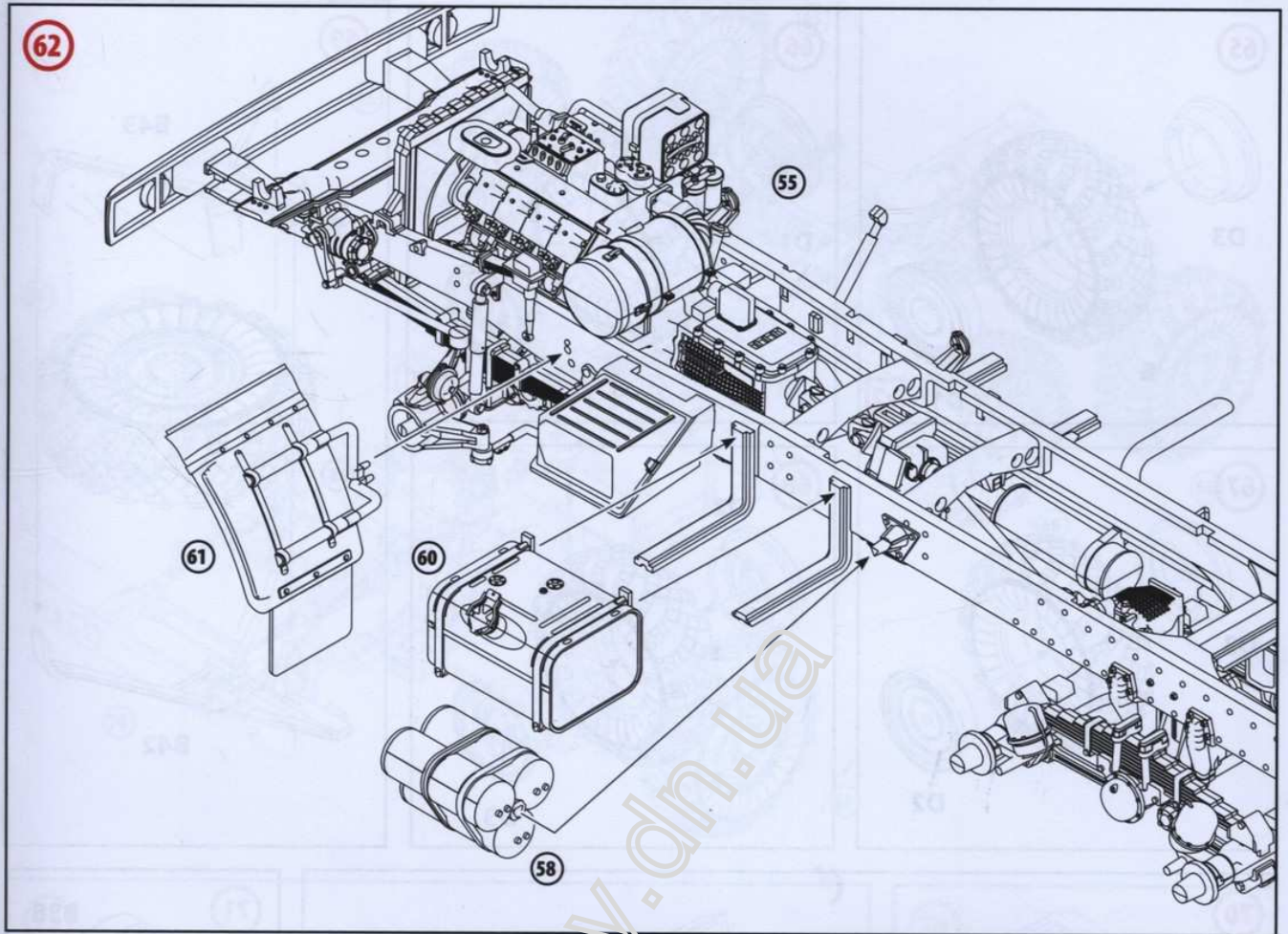

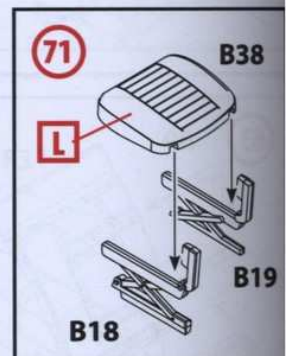
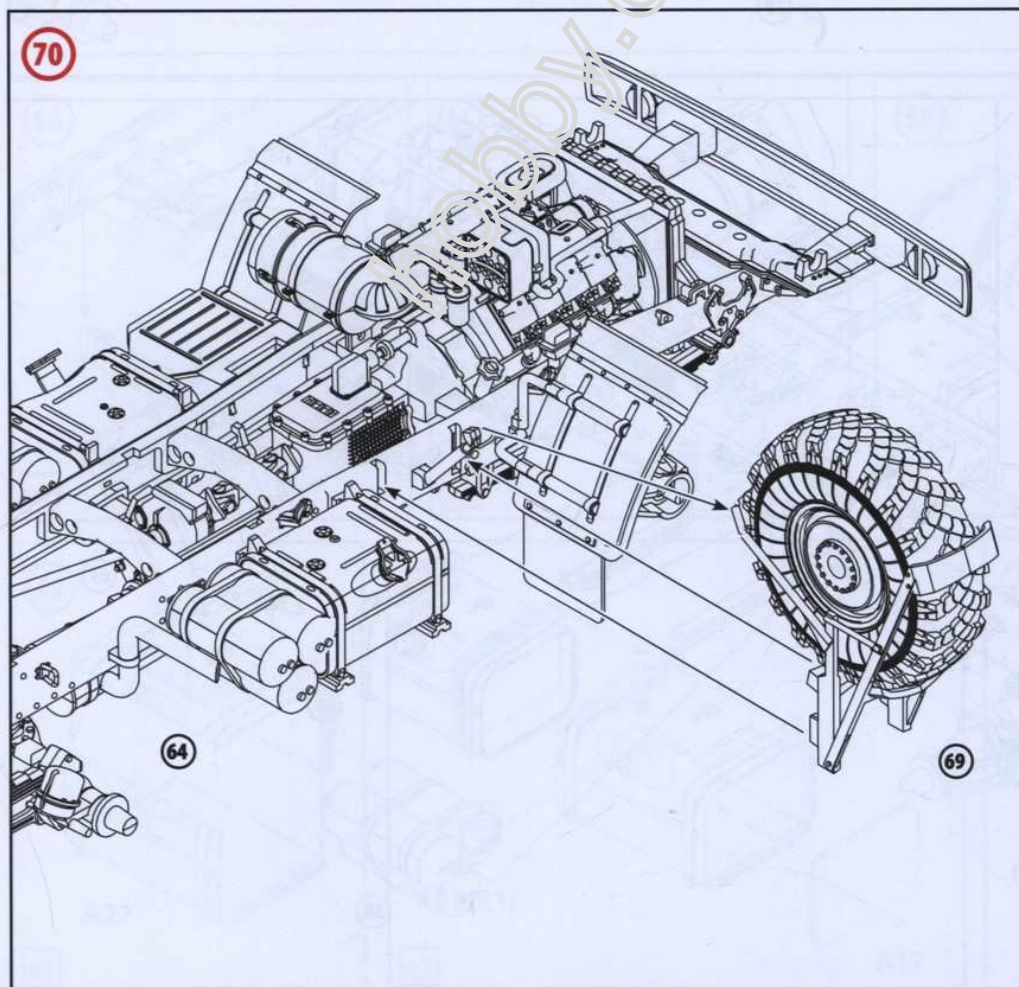
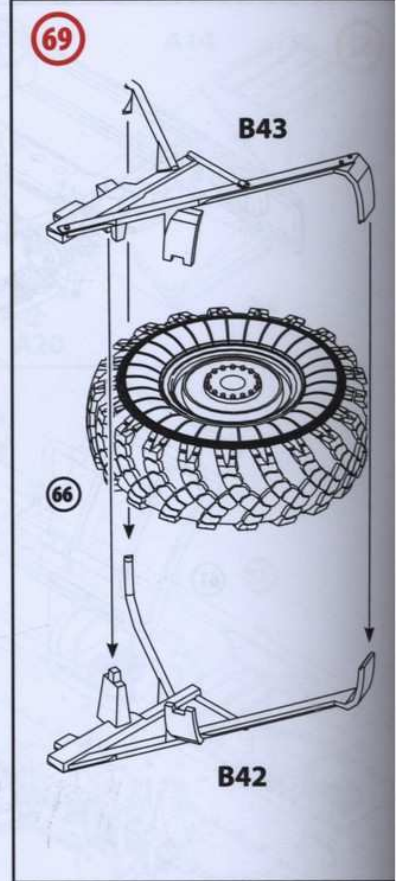
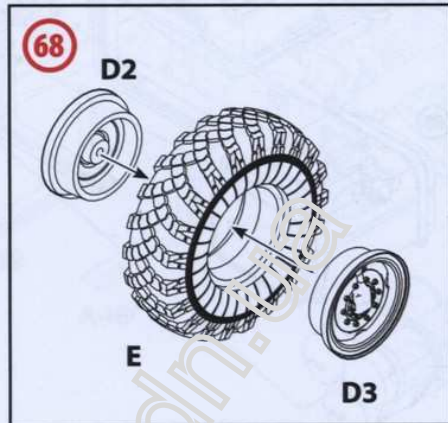
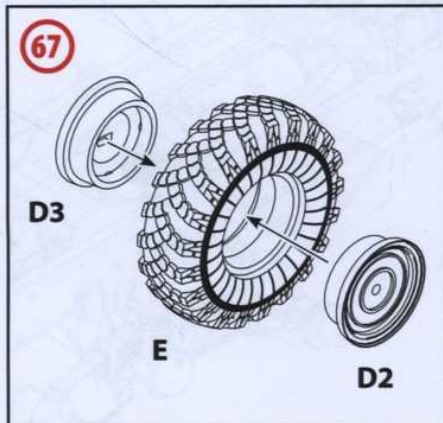
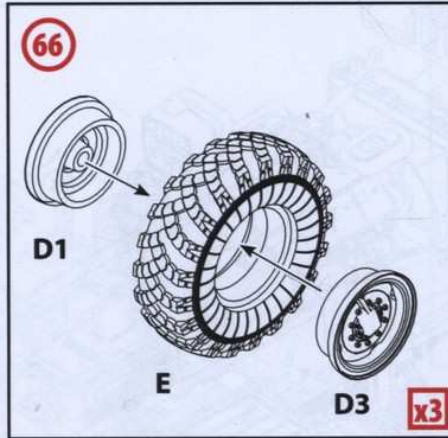
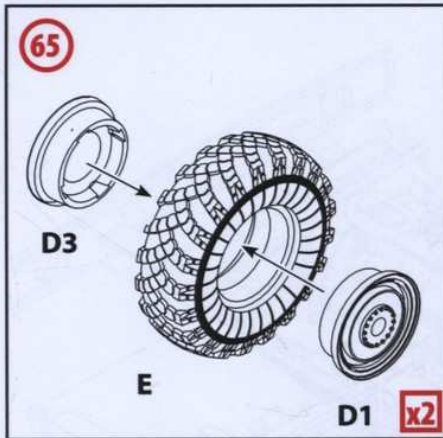

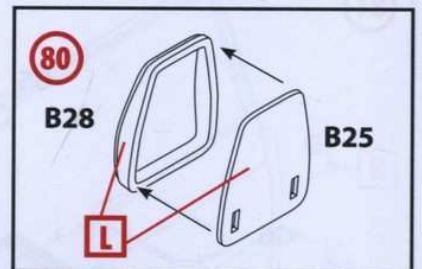
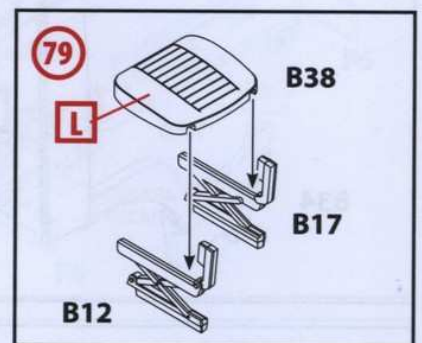
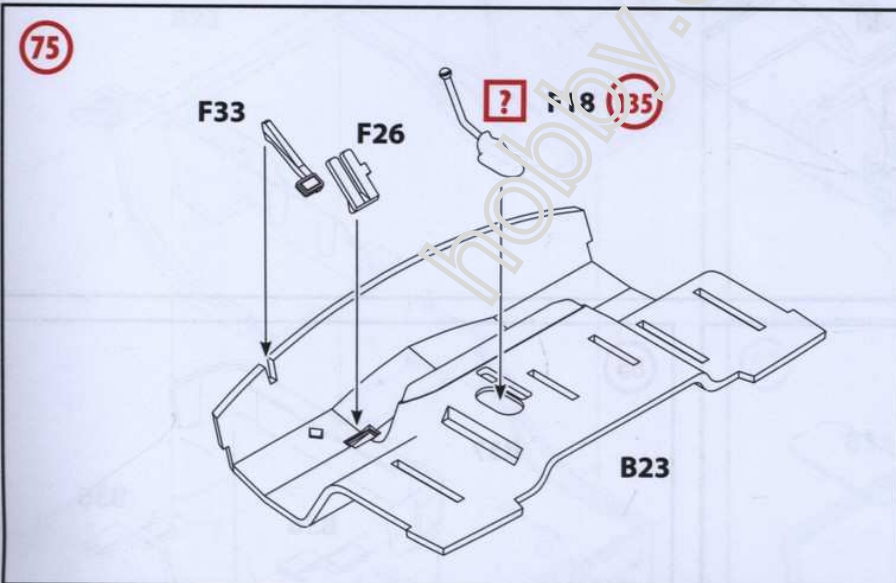
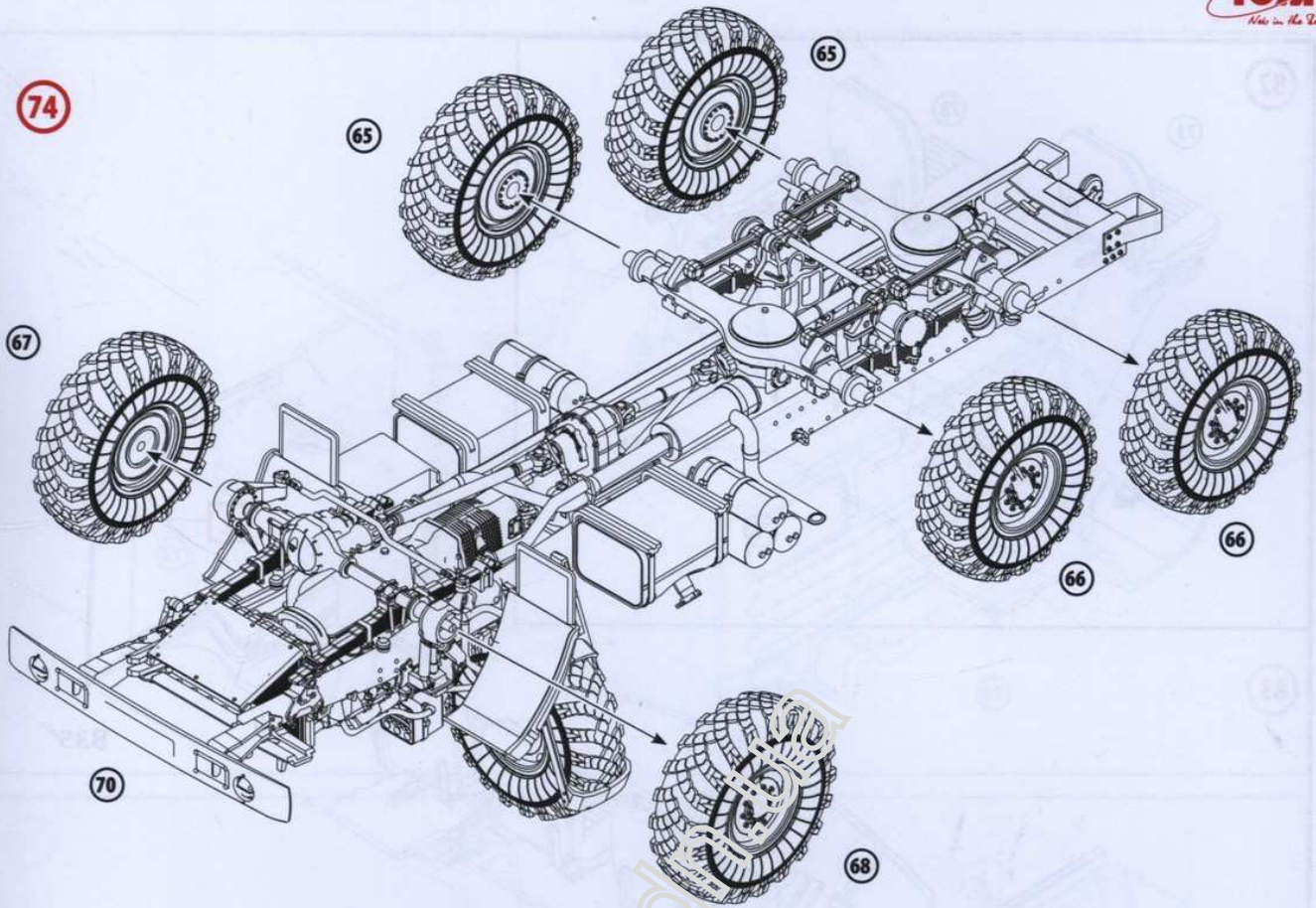

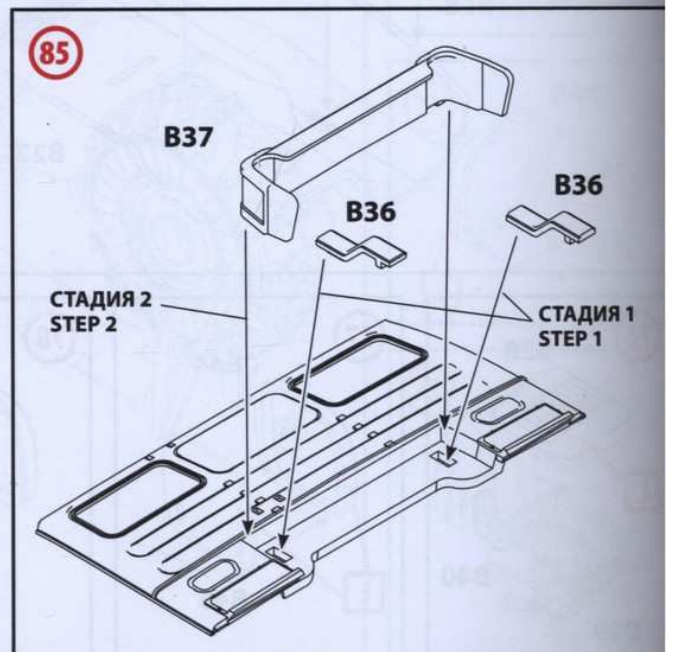
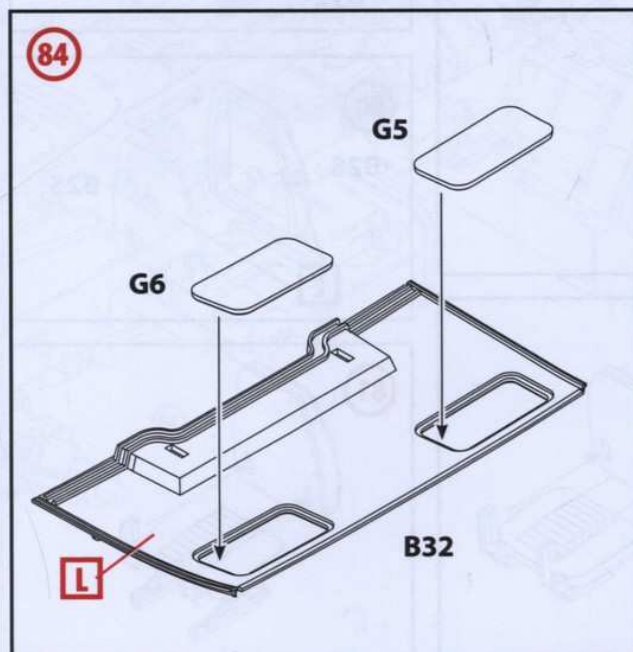
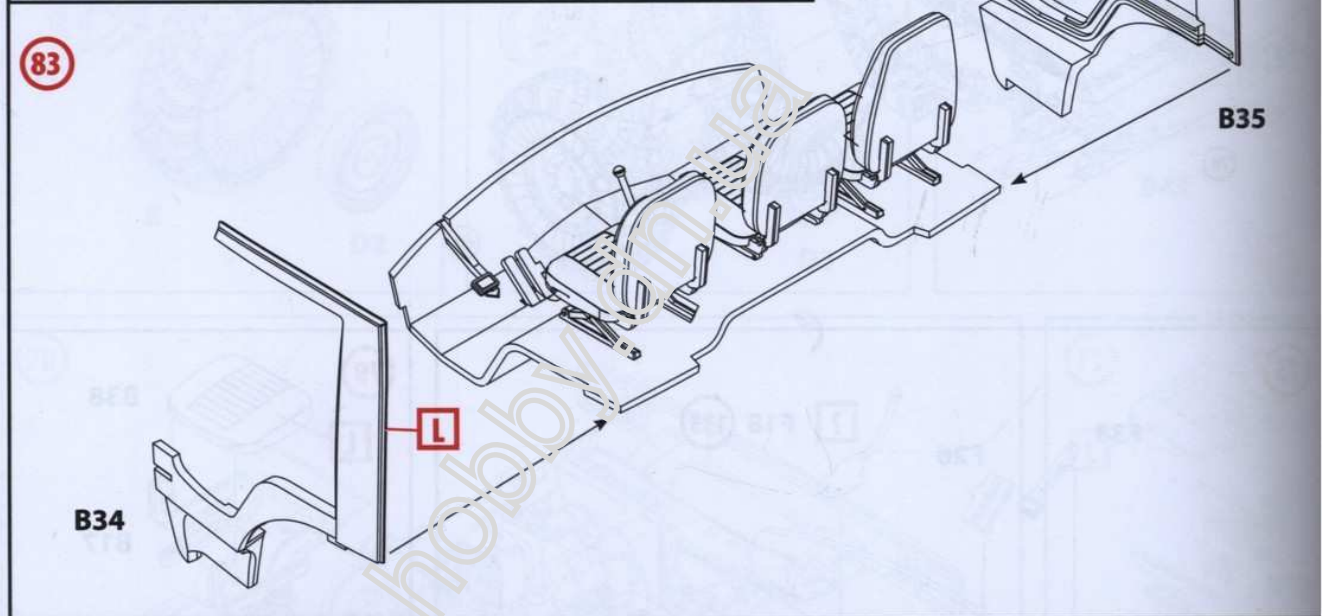
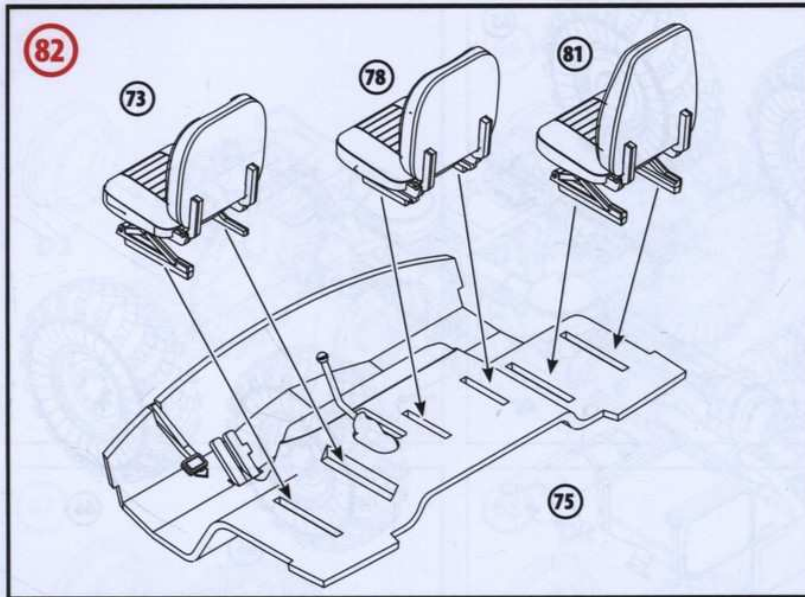

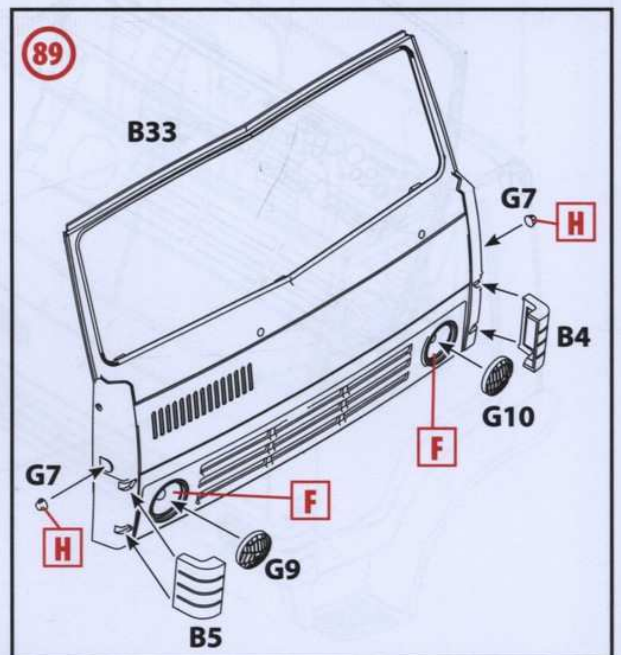
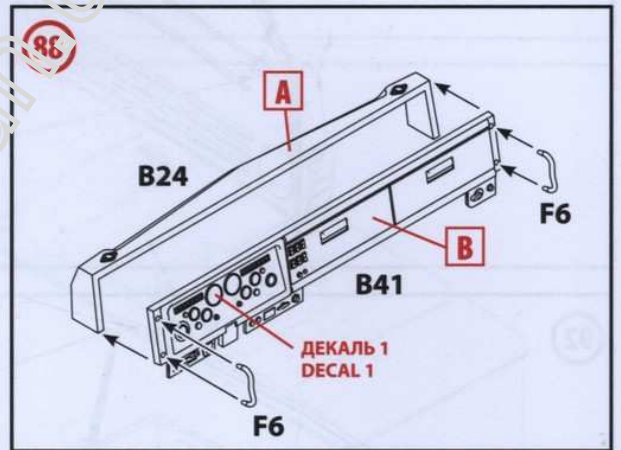
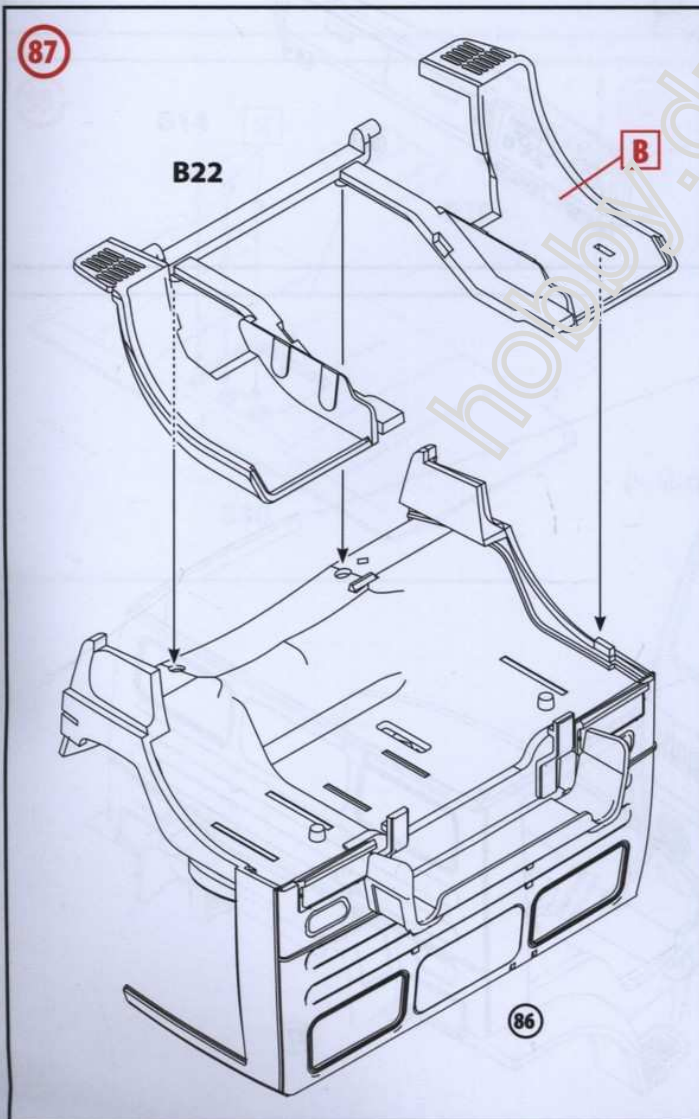
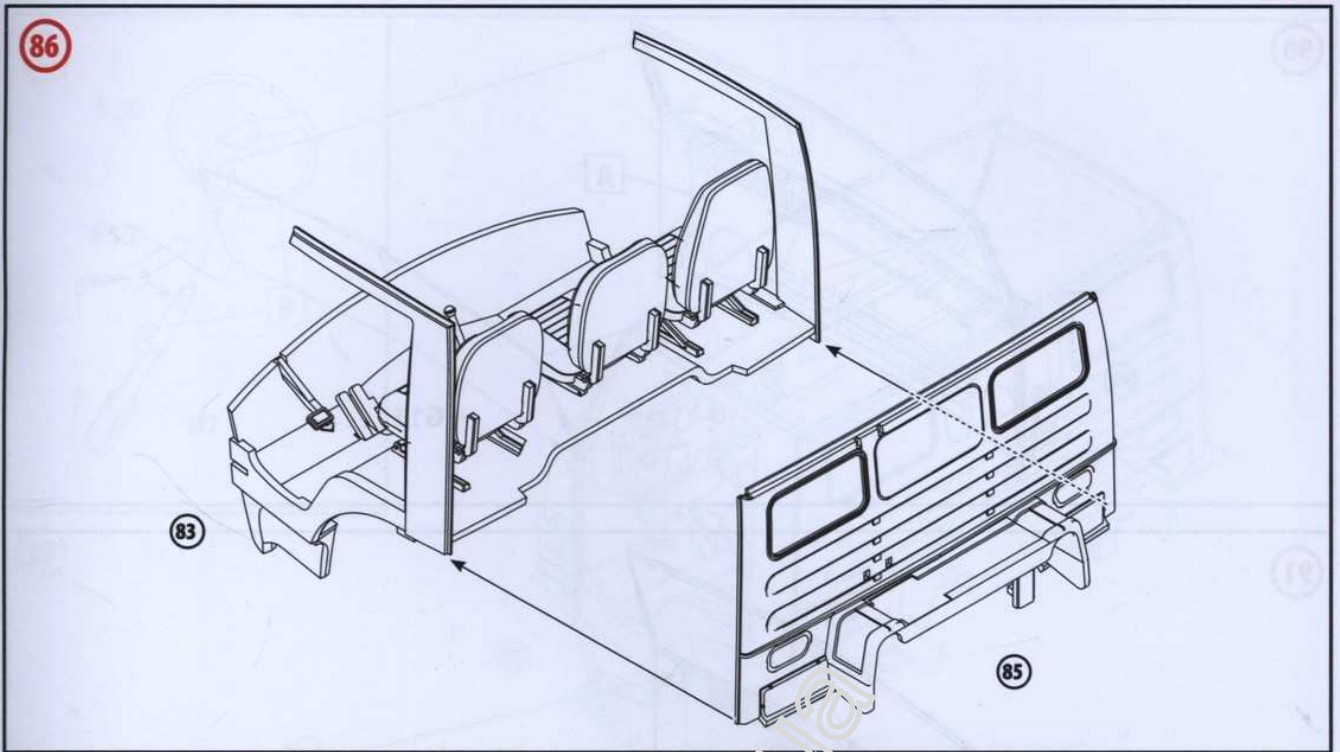

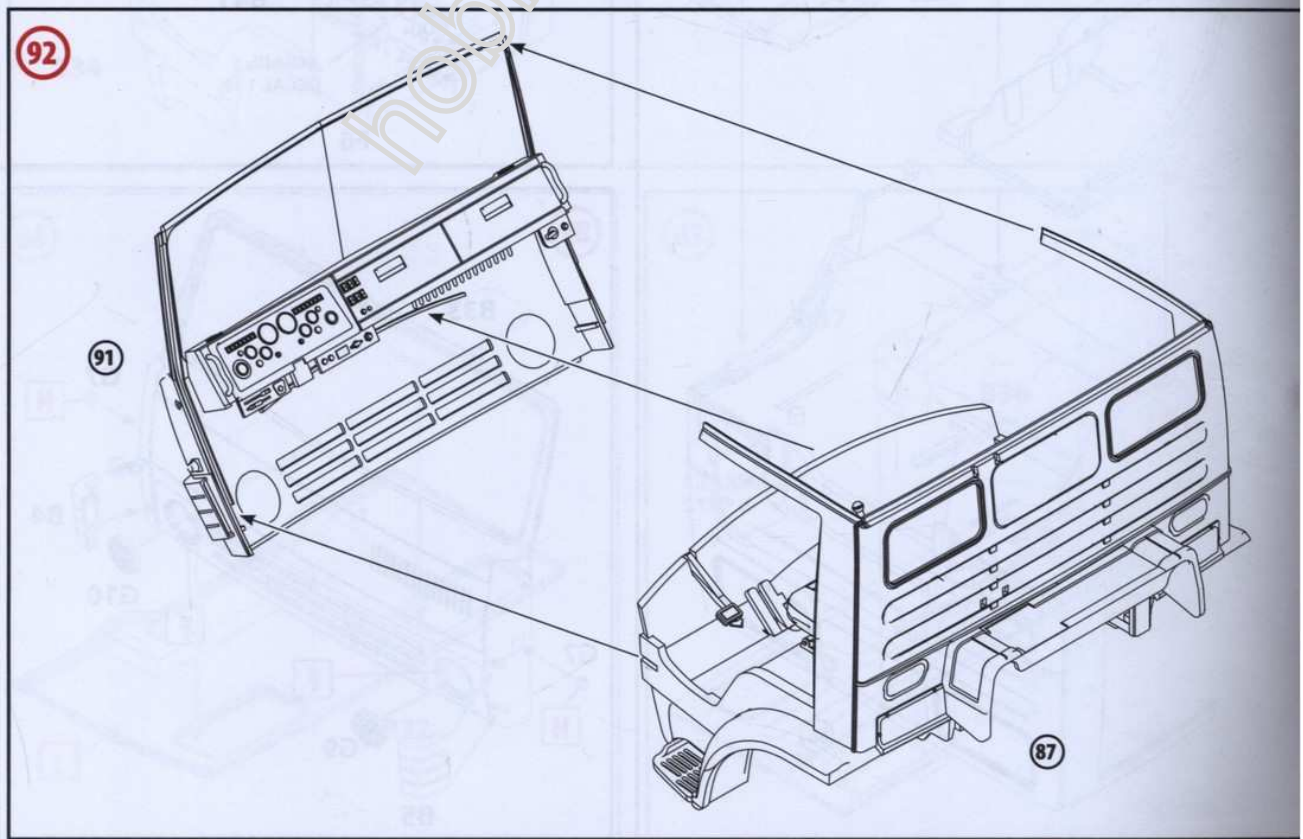
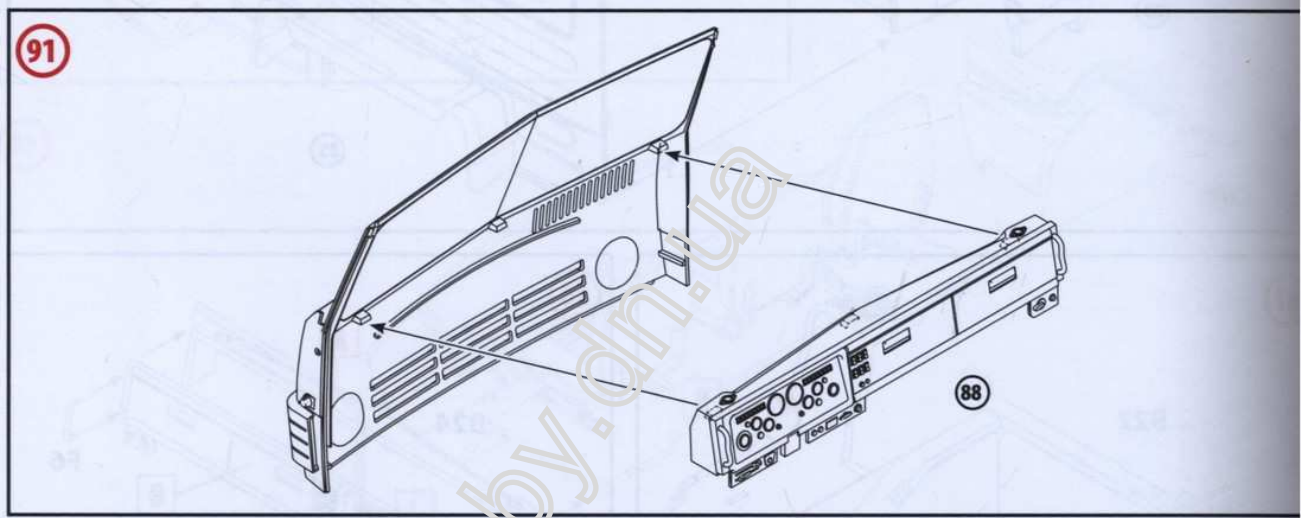
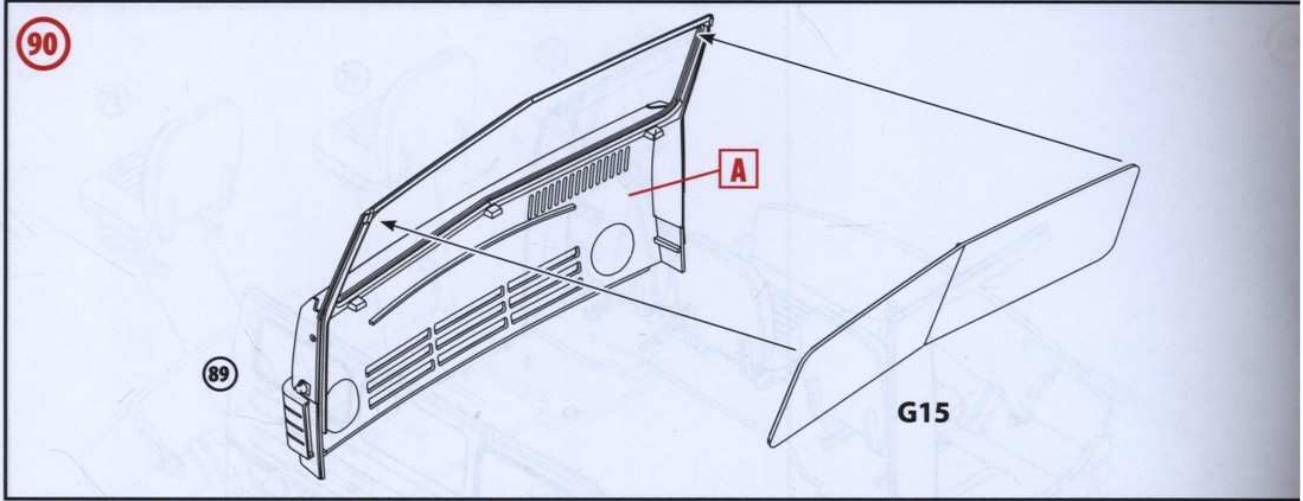

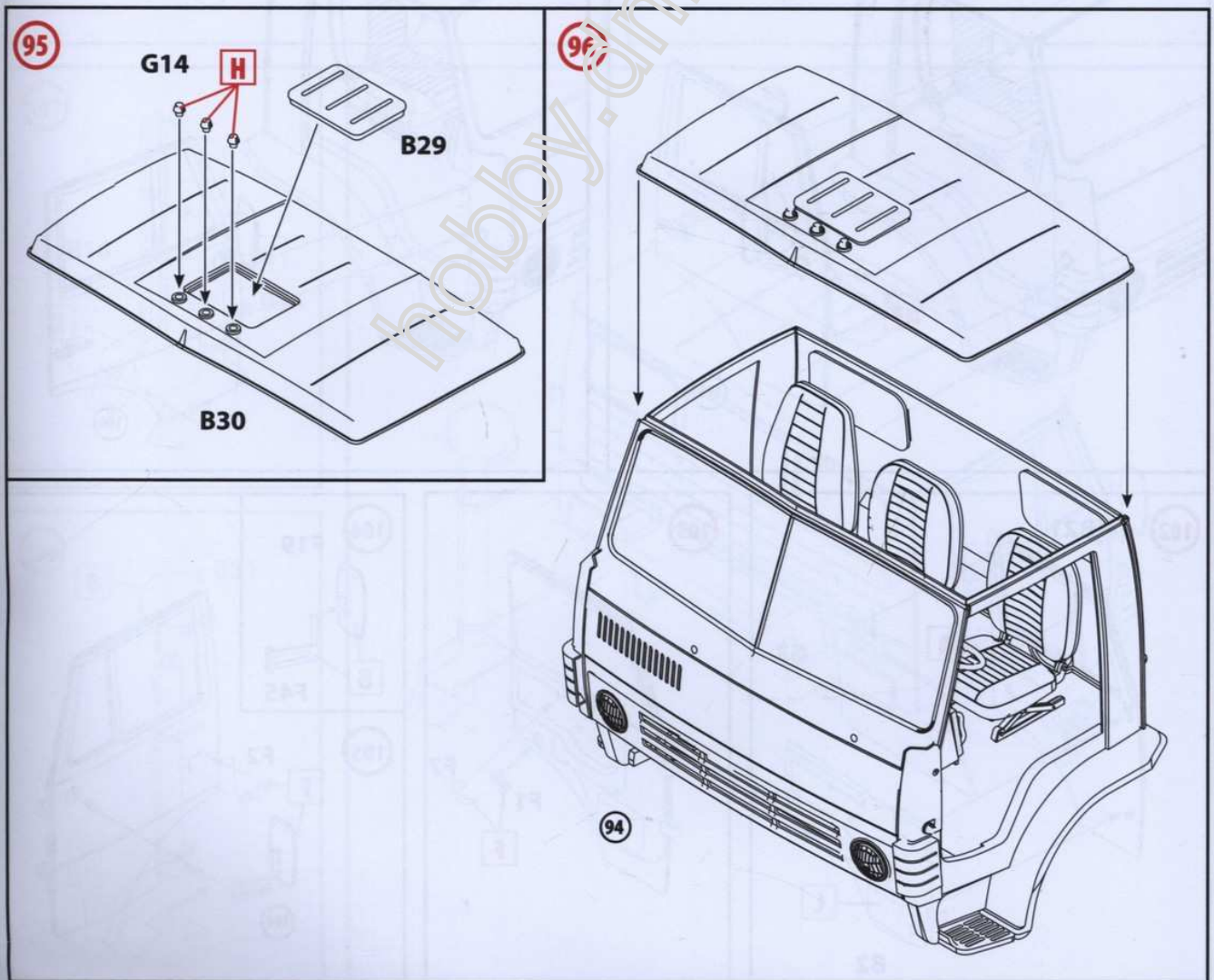
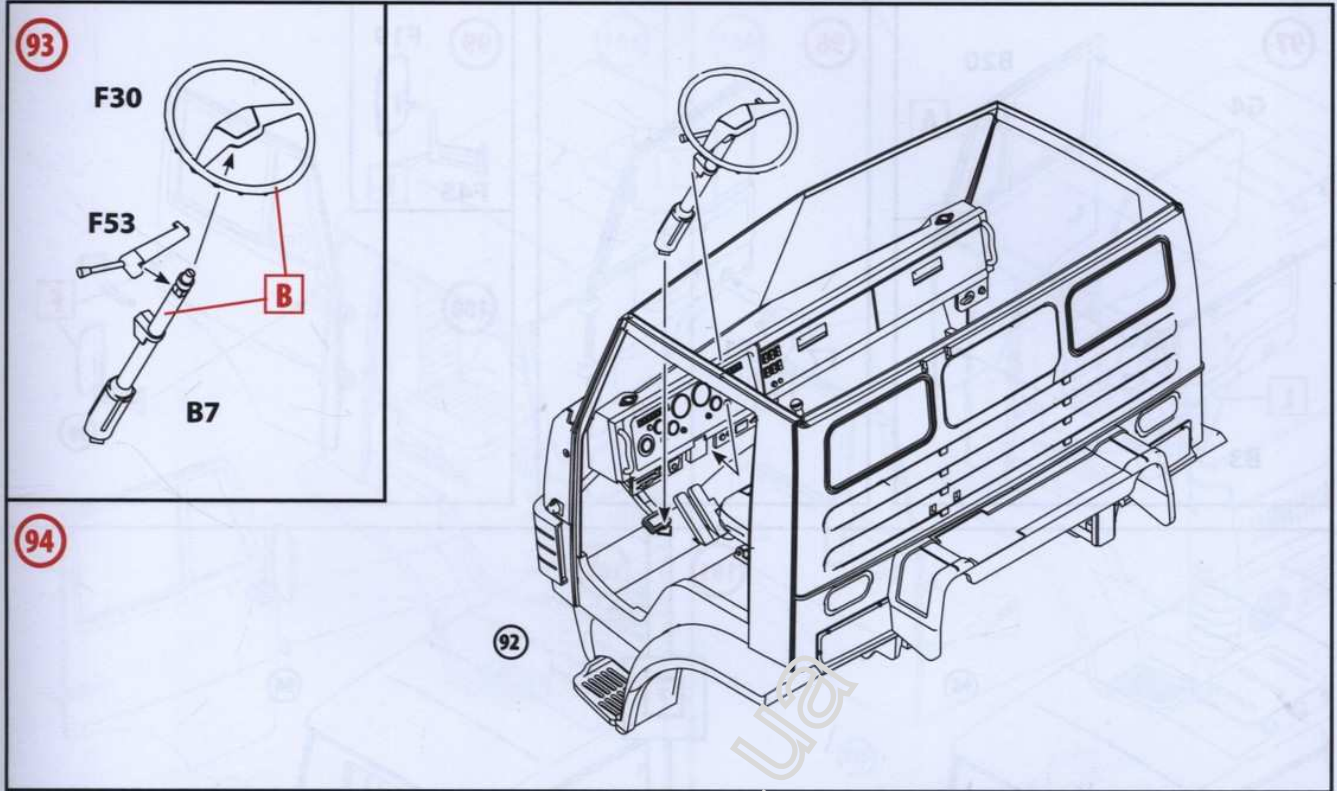

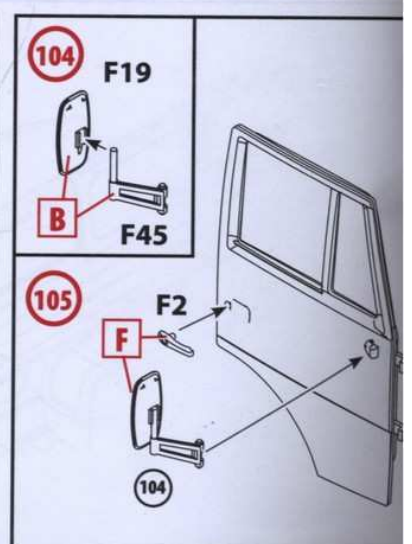
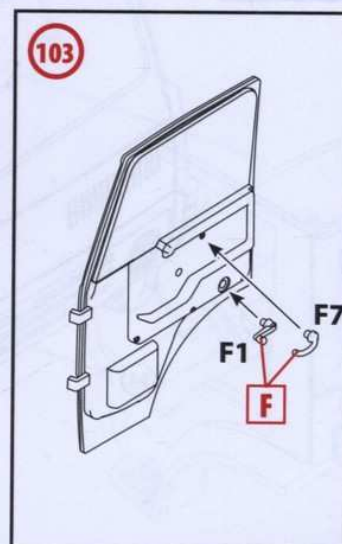
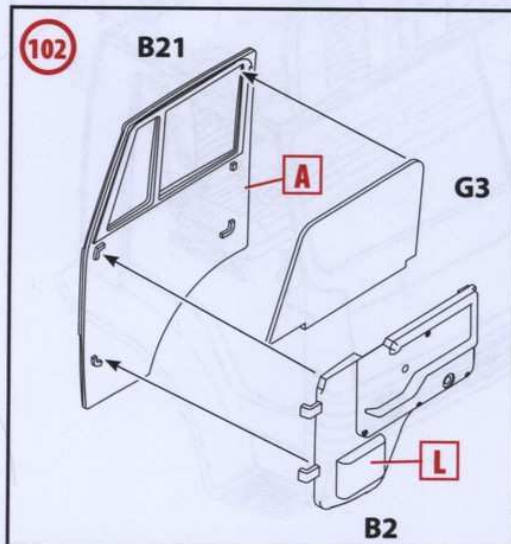
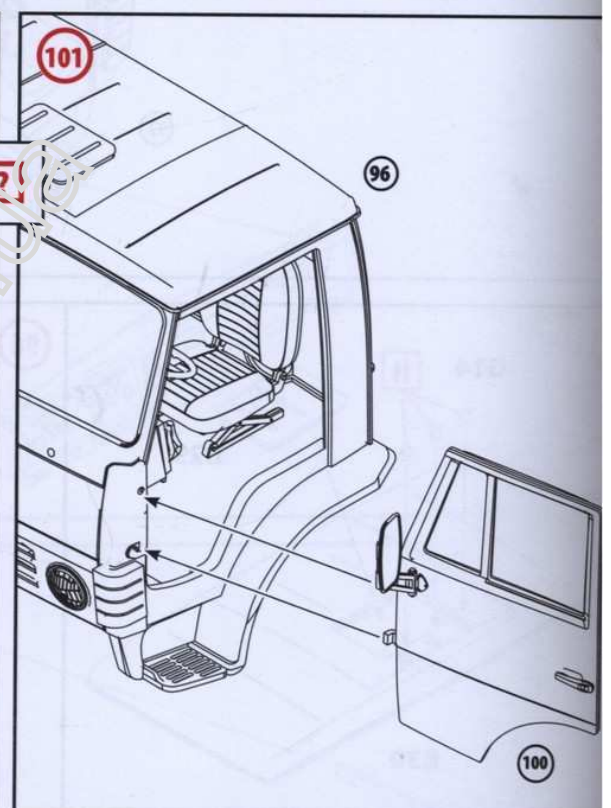
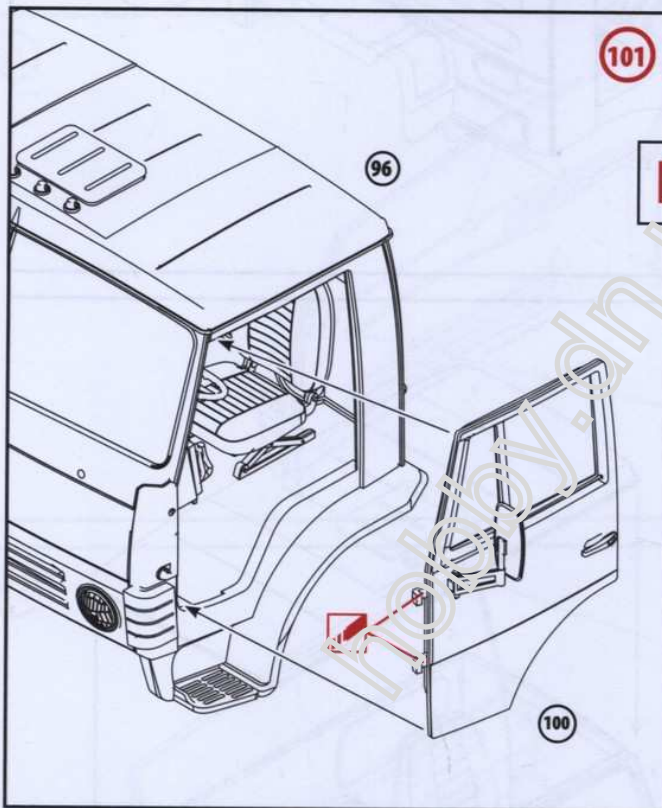
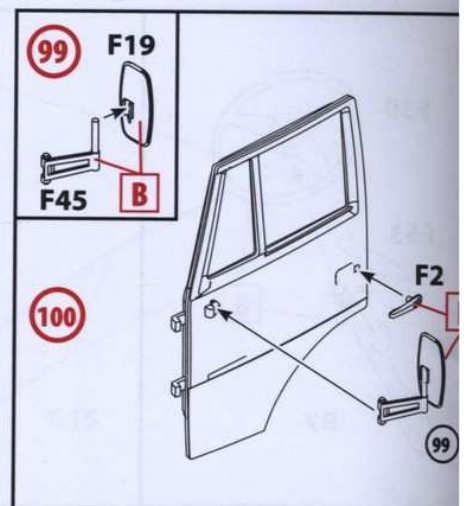
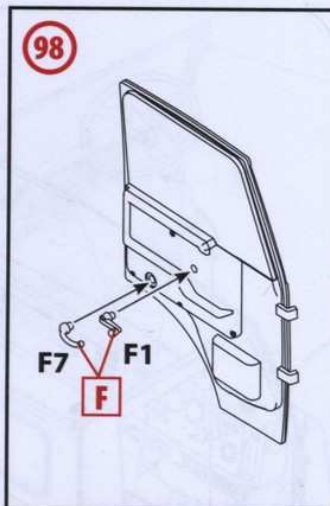
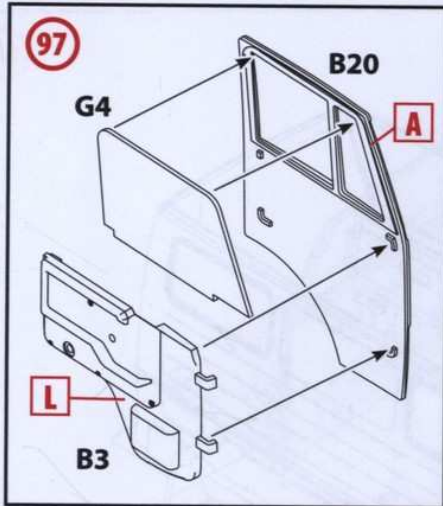

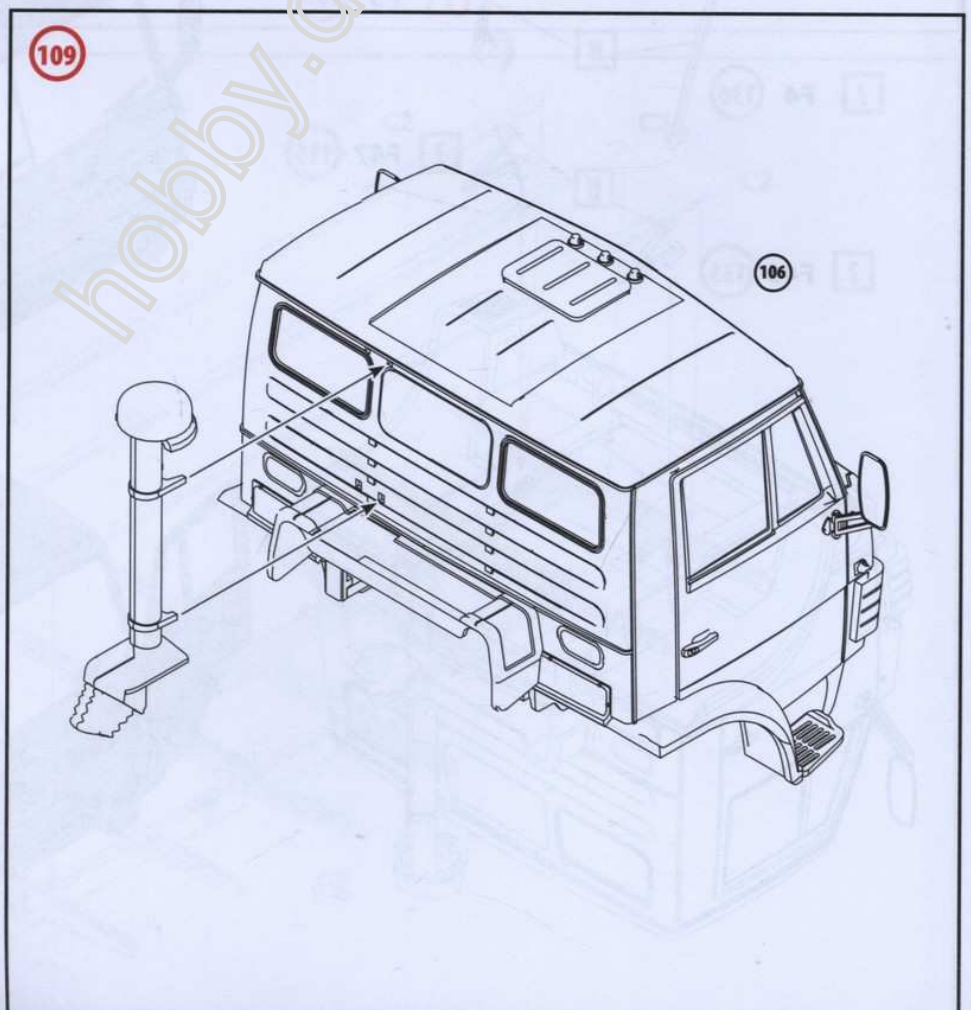
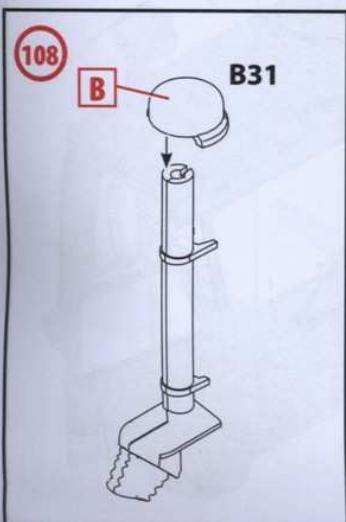
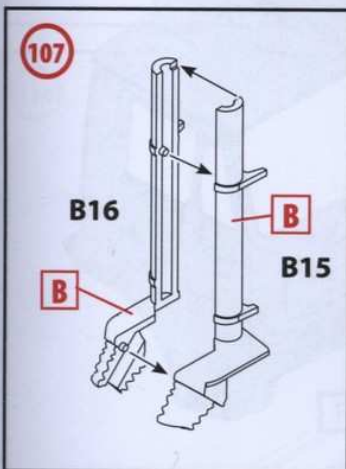
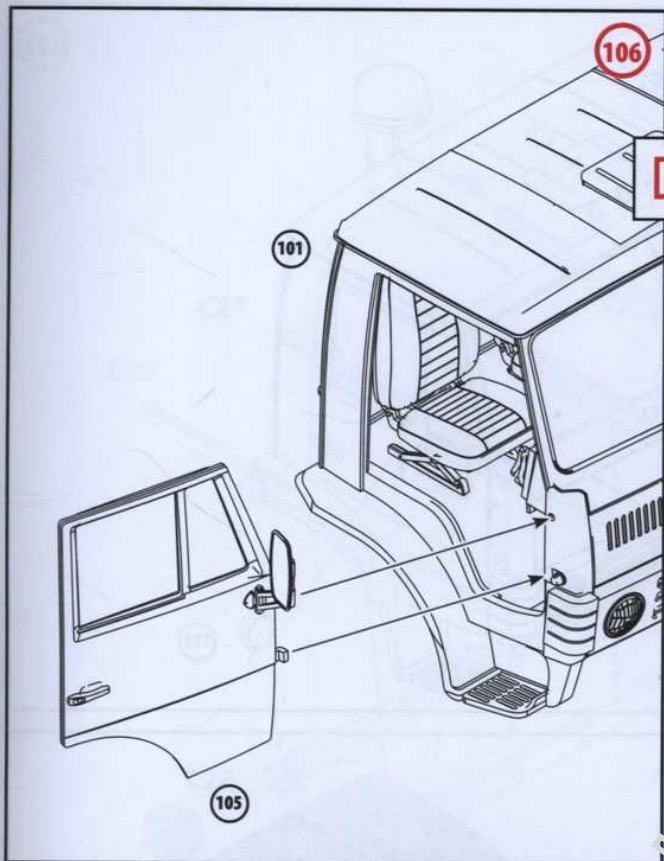

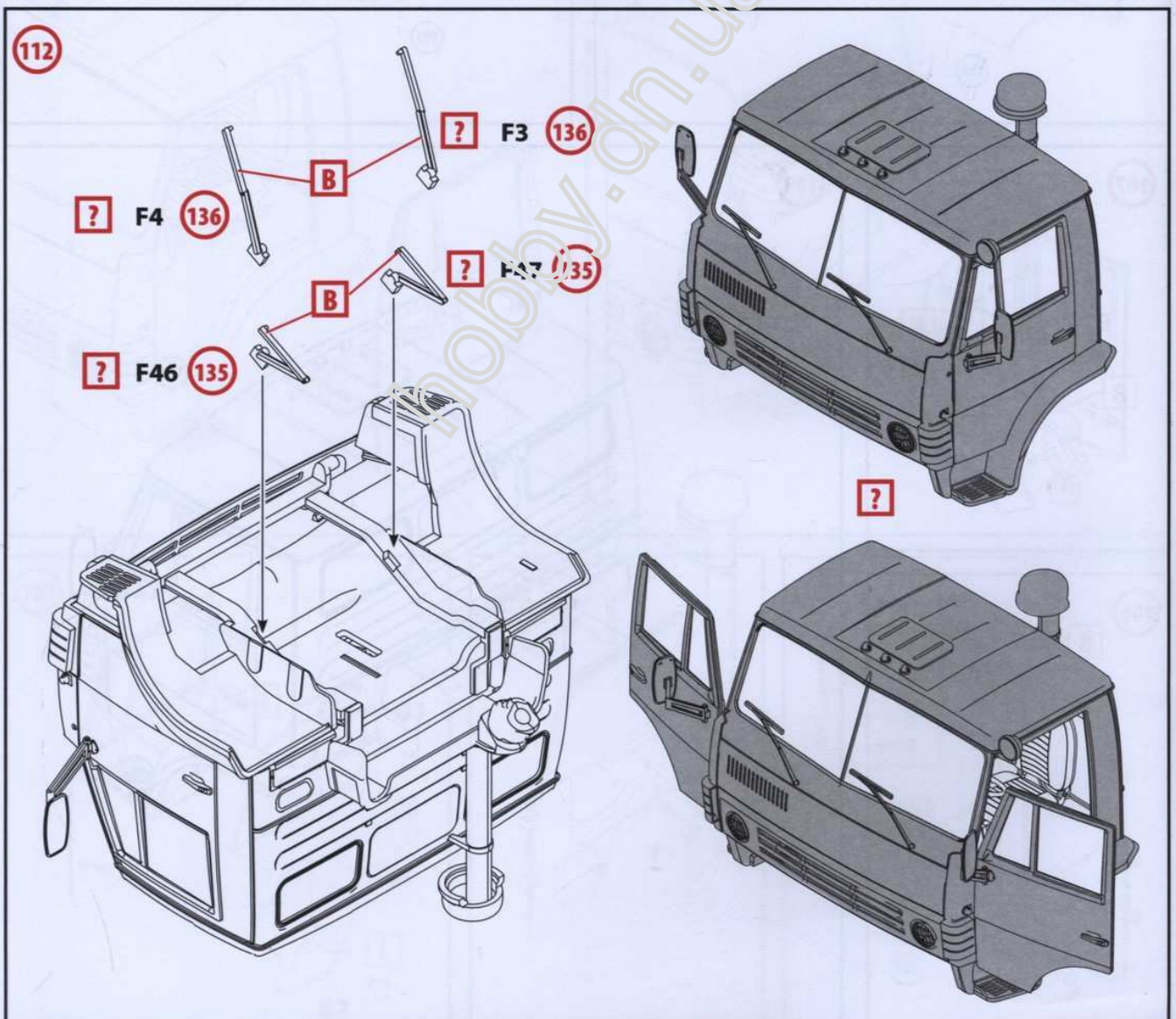
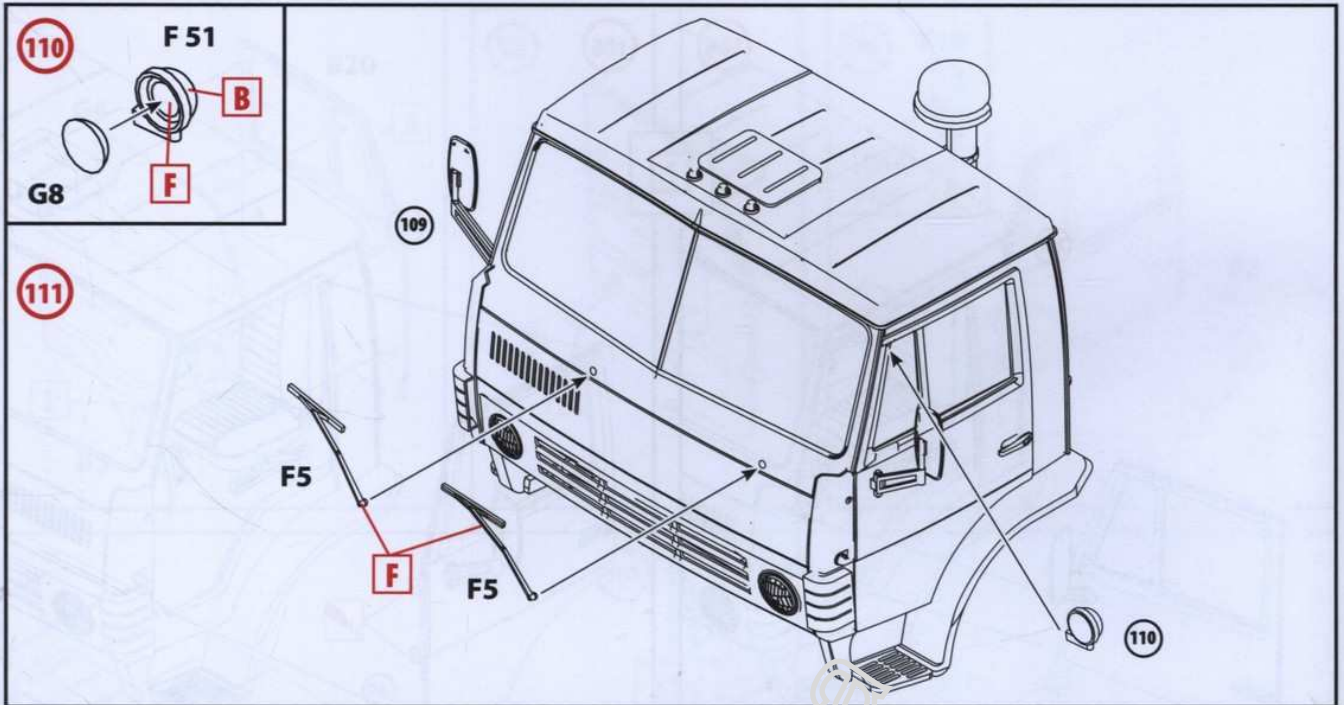

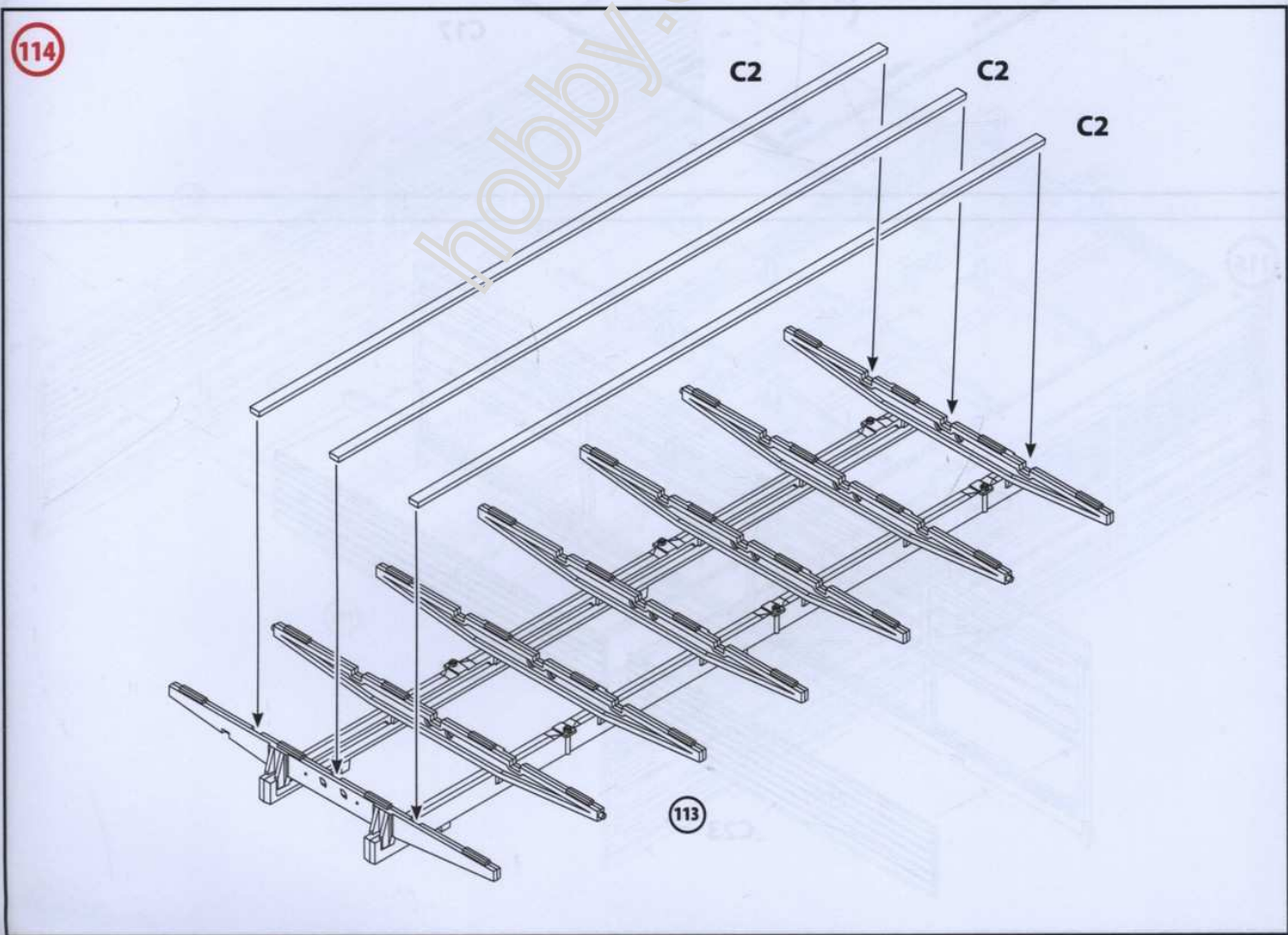
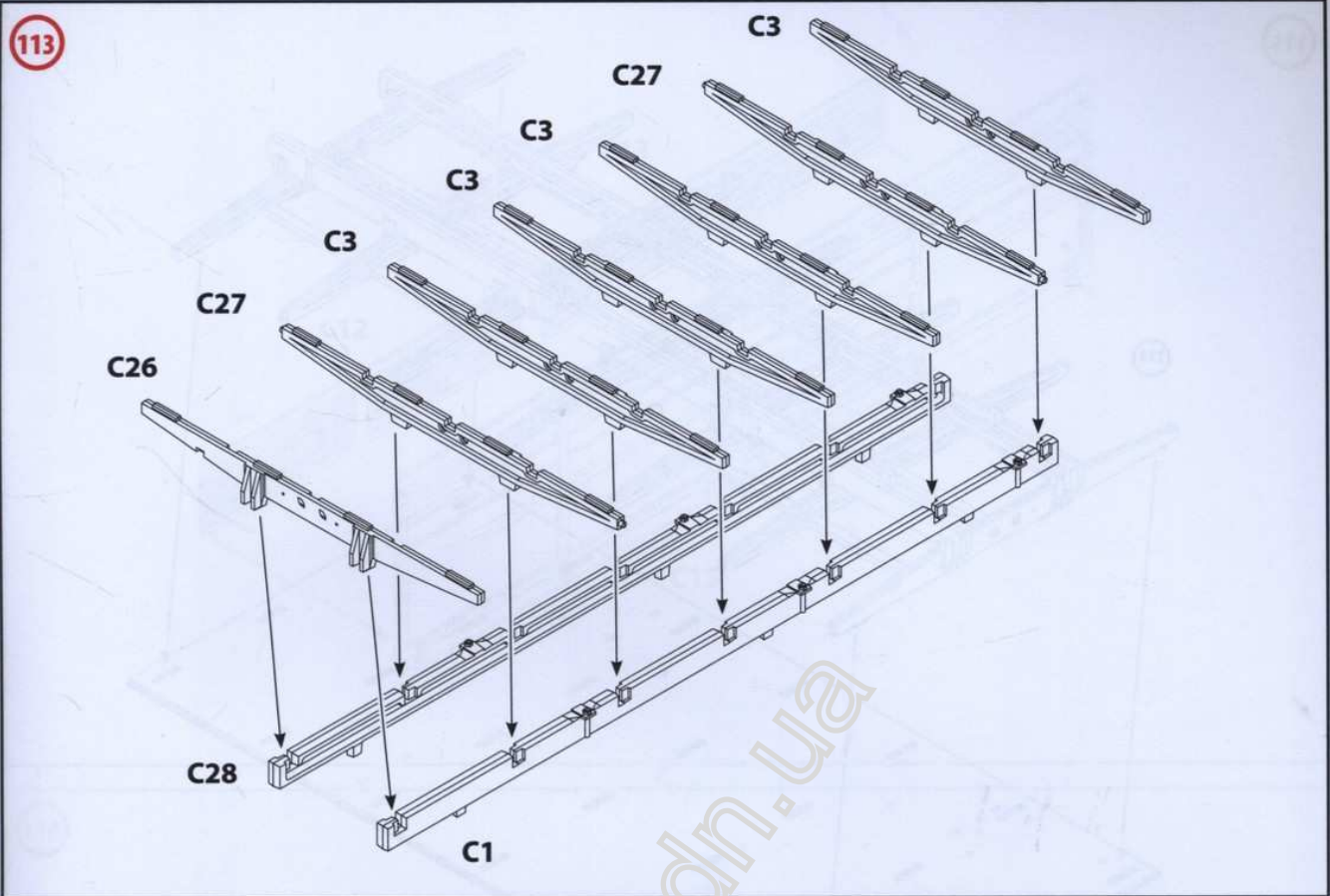

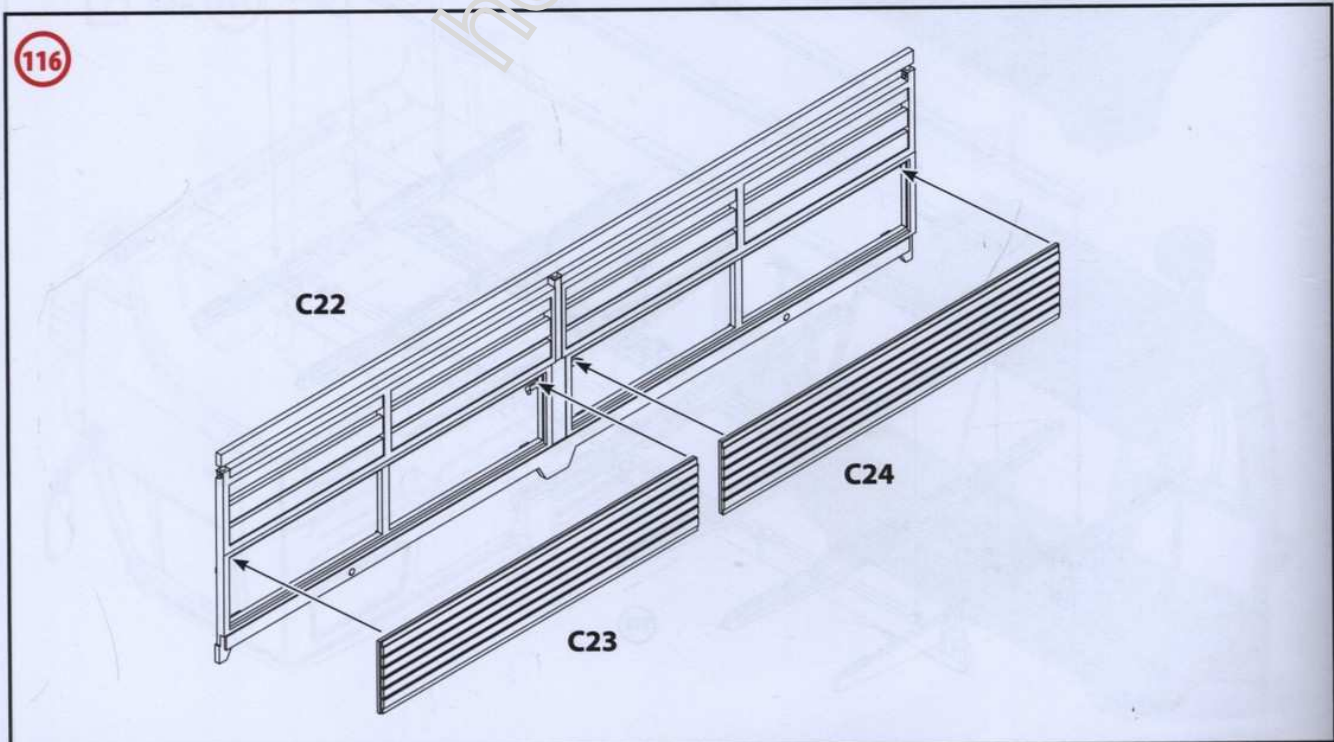
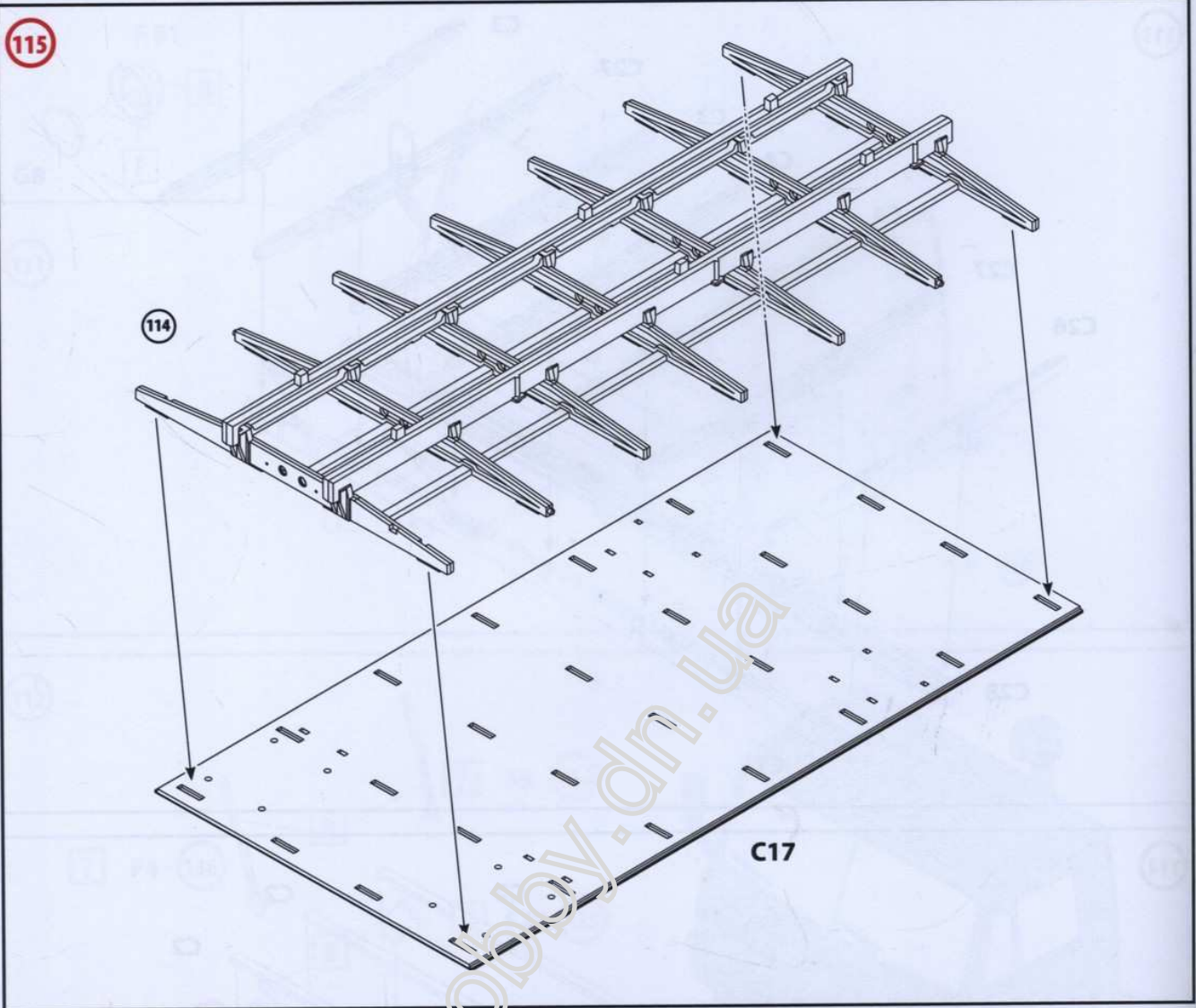

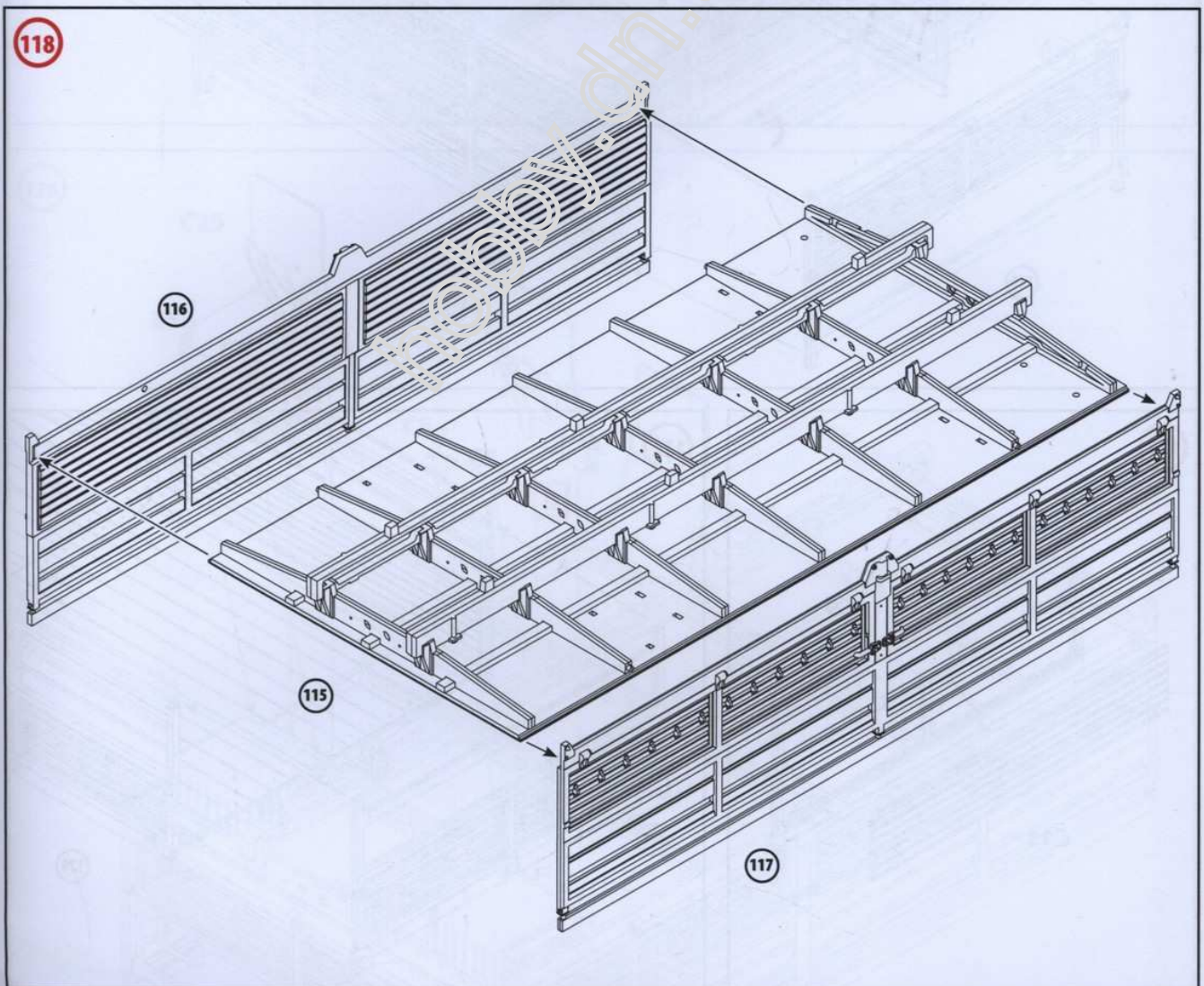
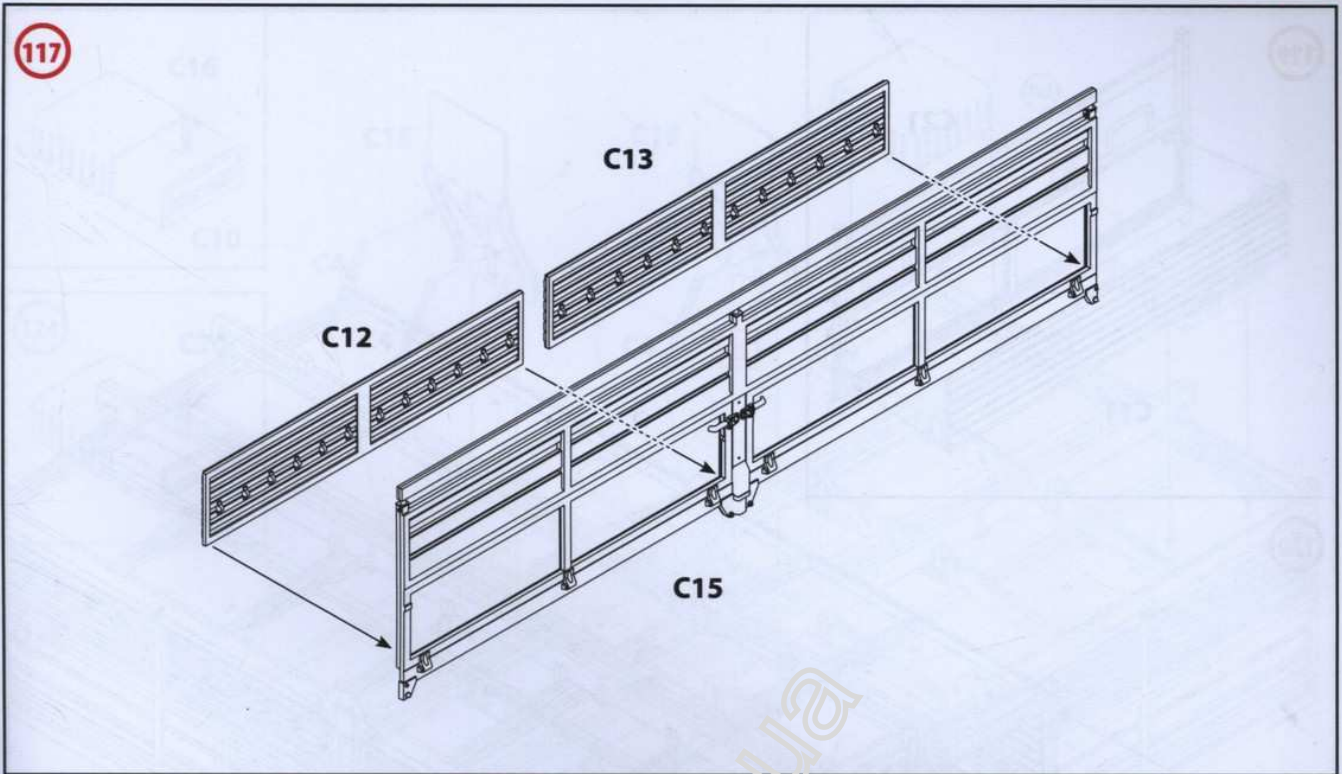

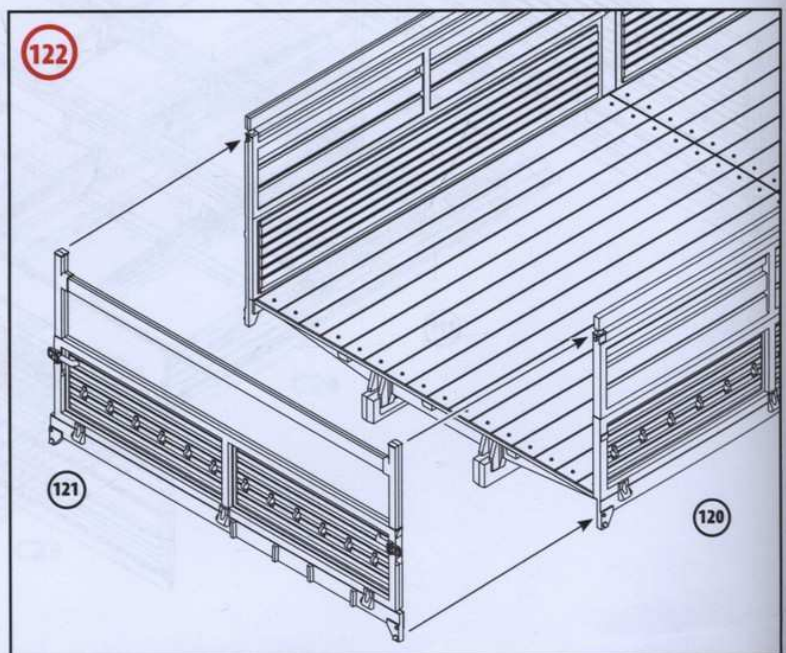
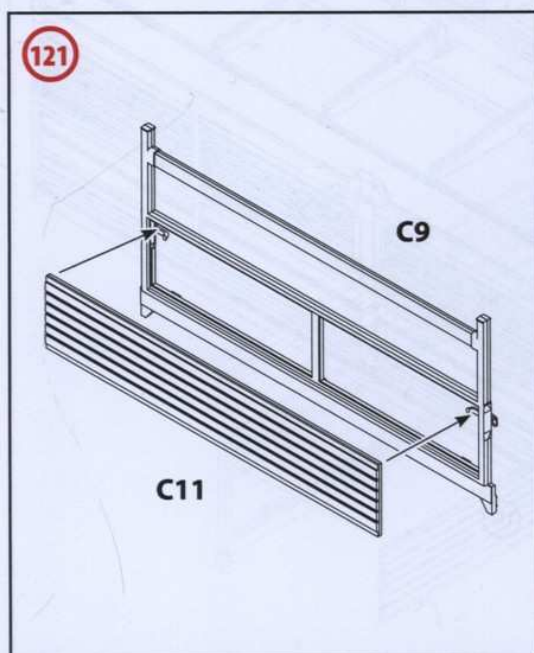
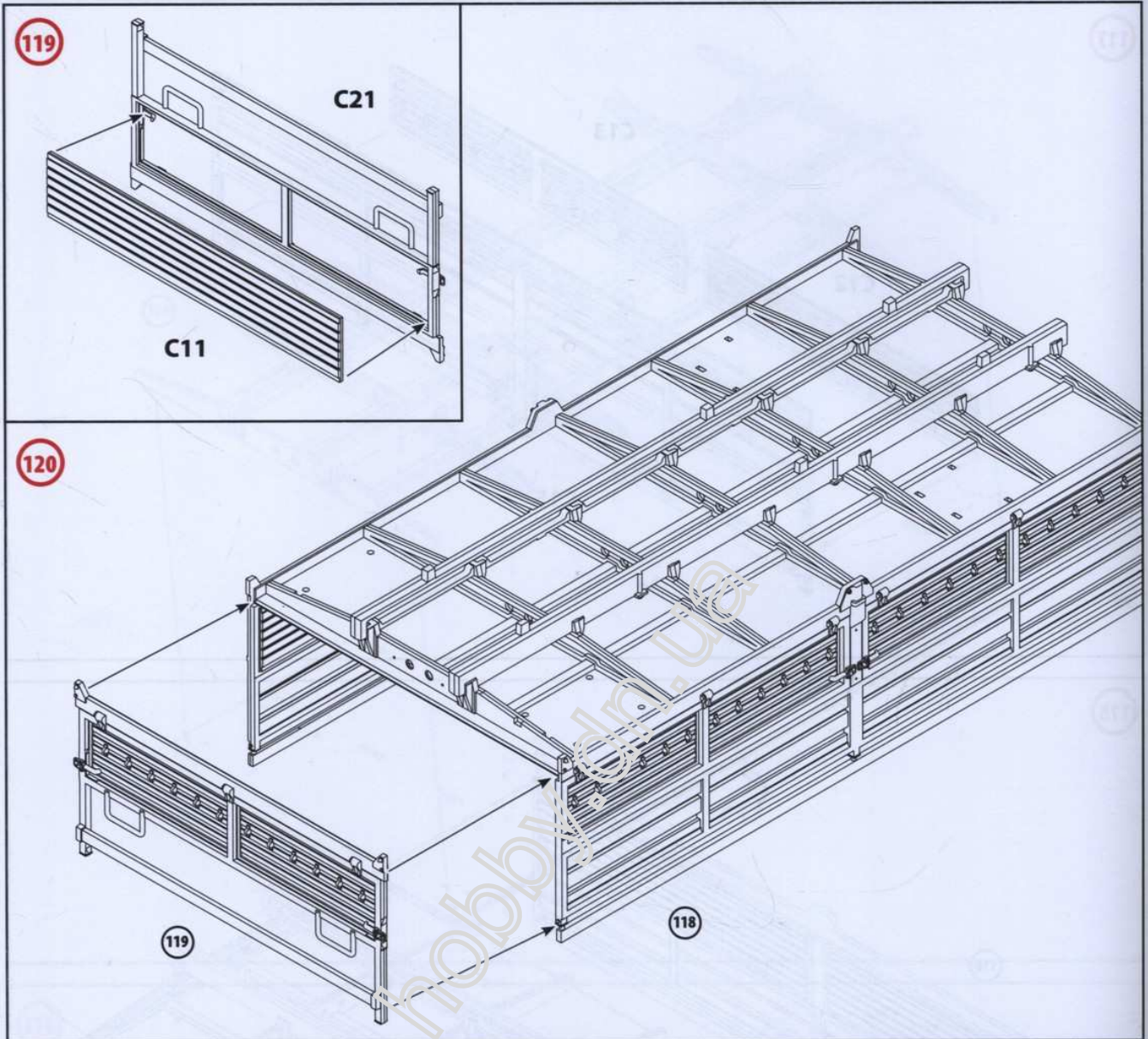

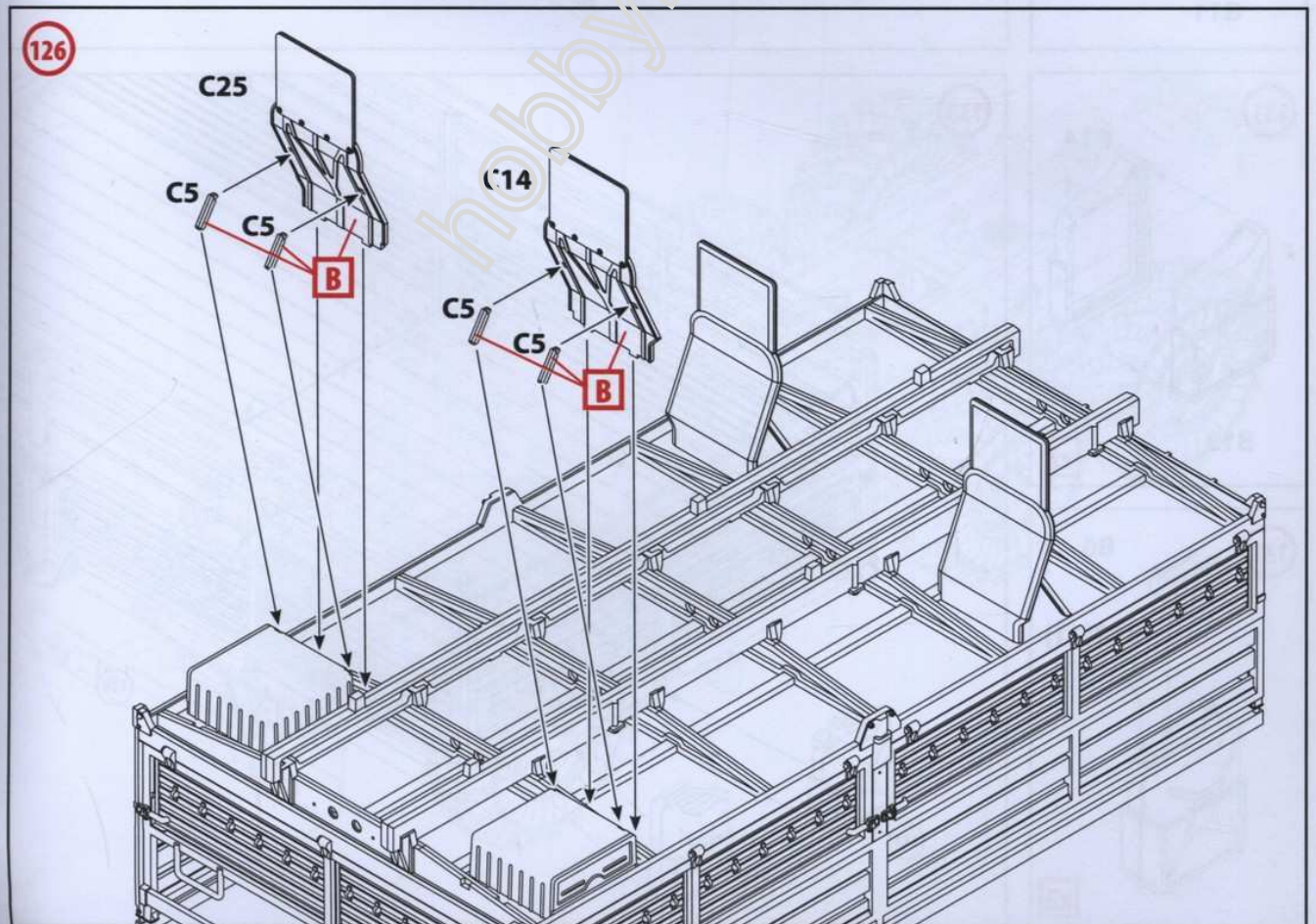
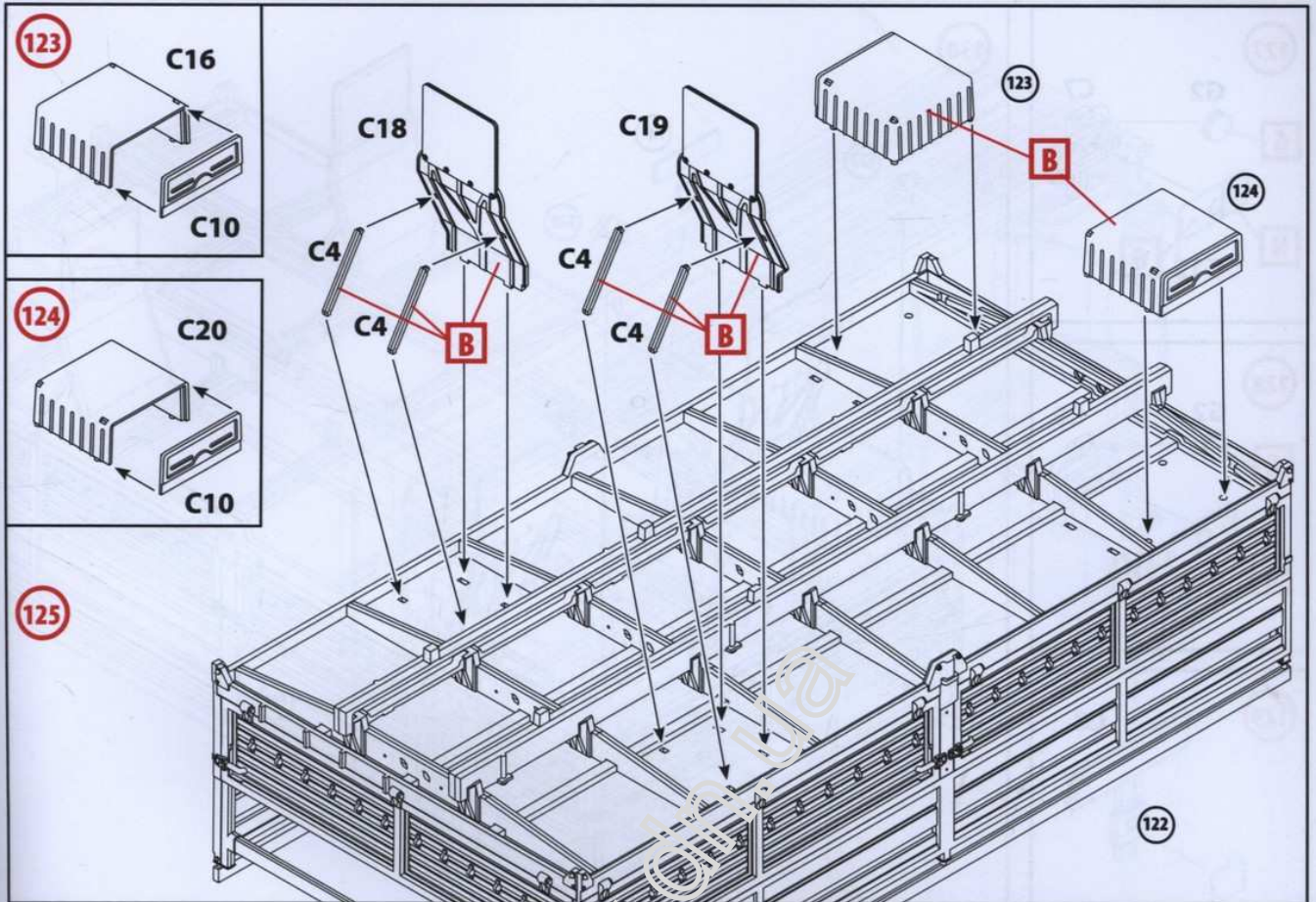

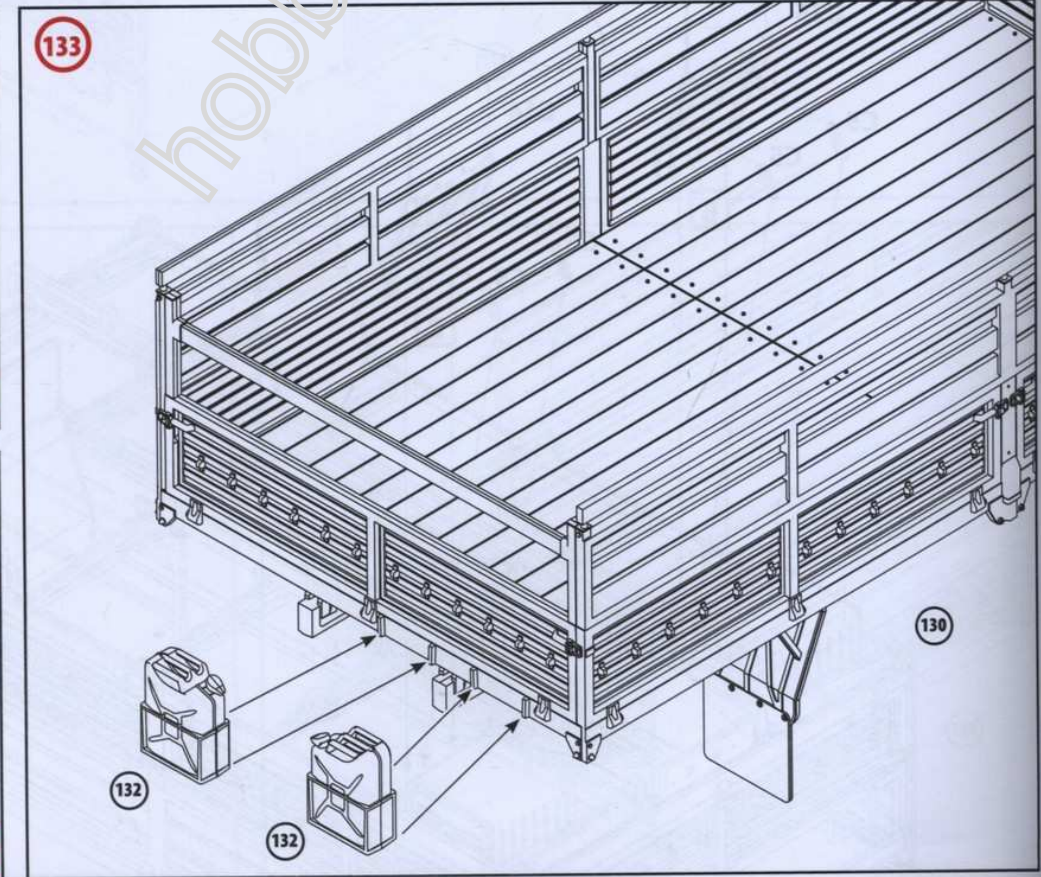
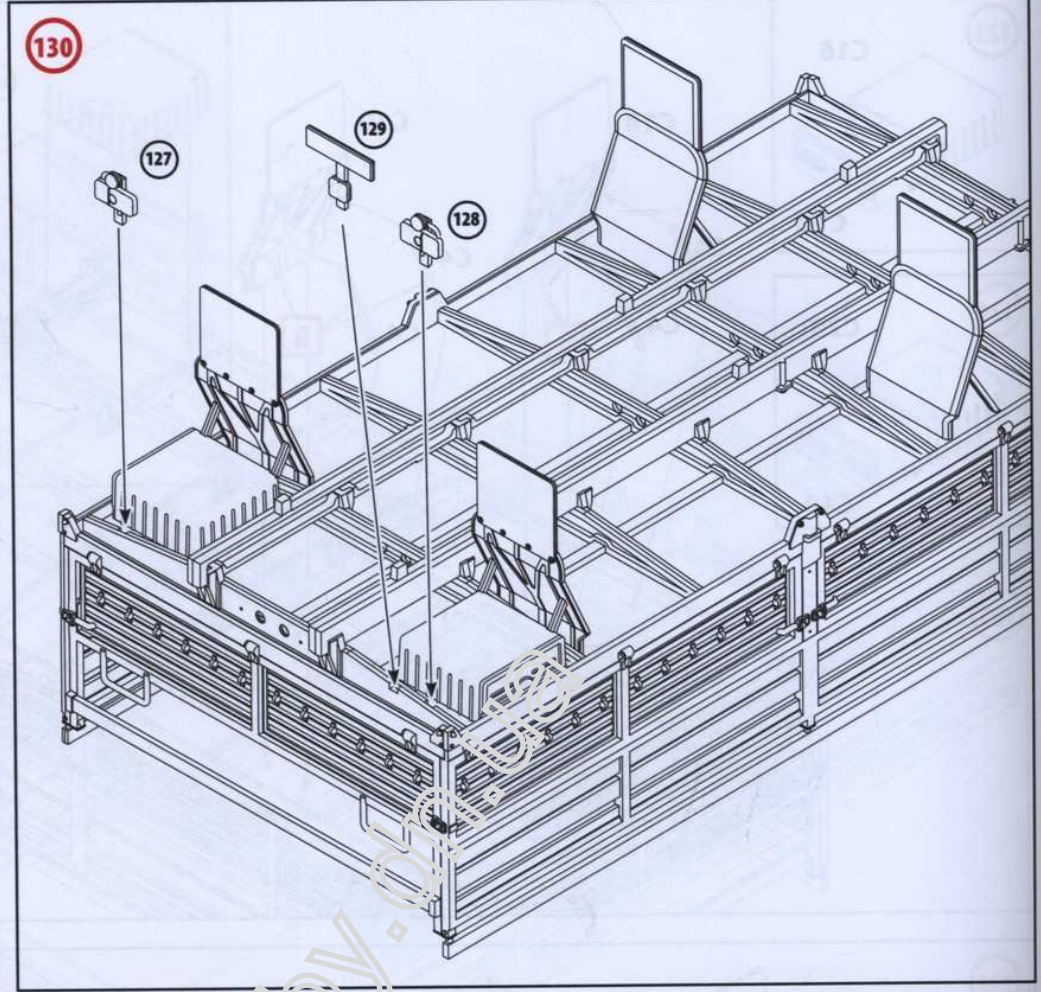
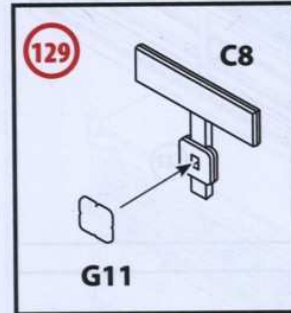
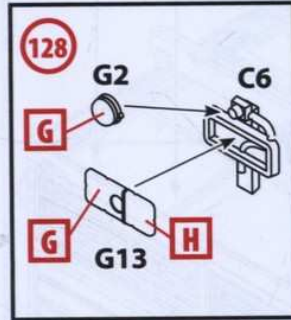
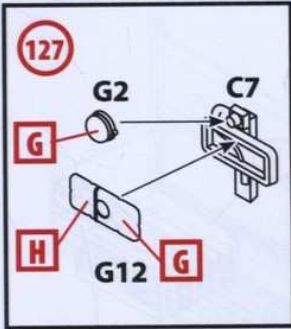

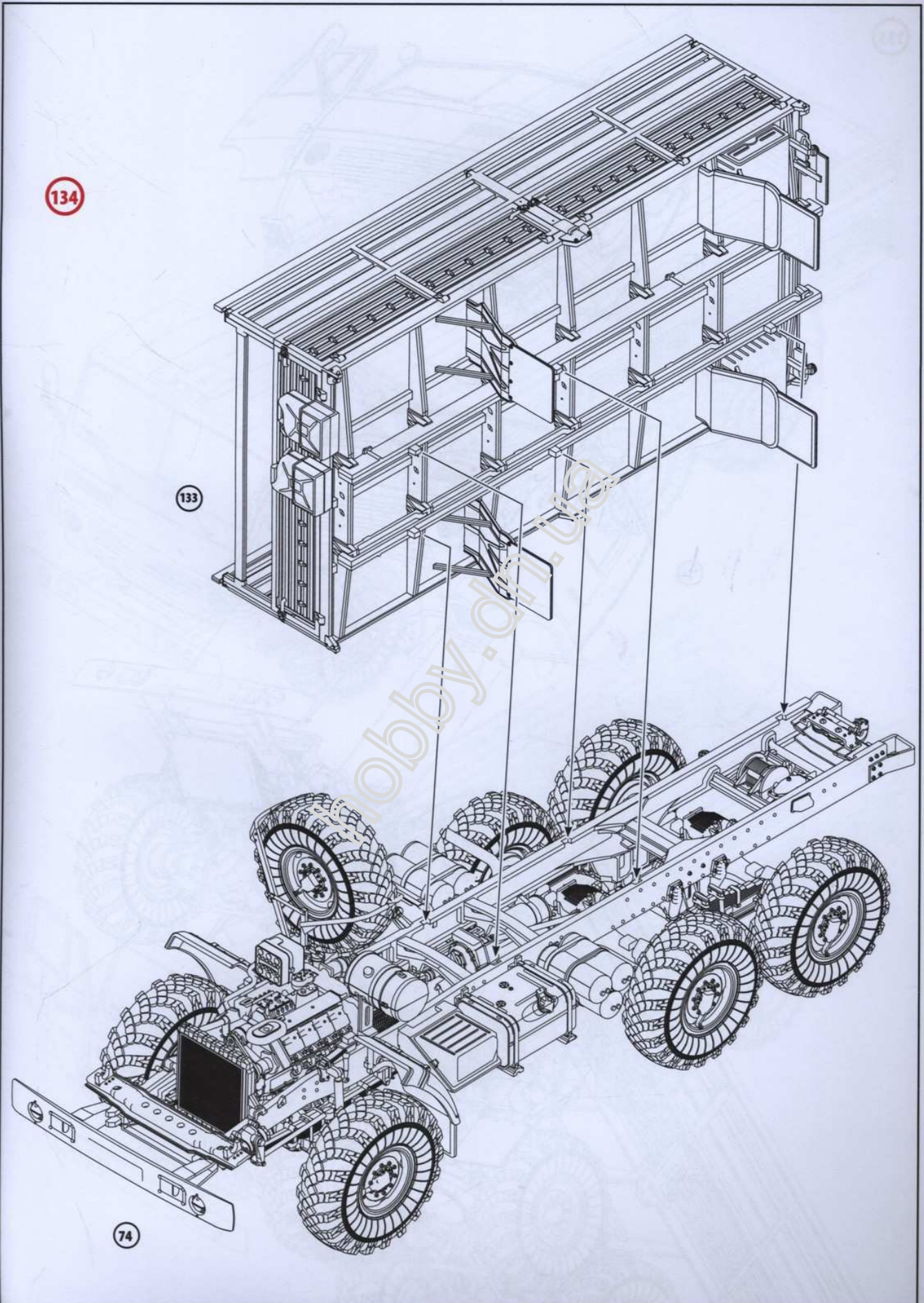

135

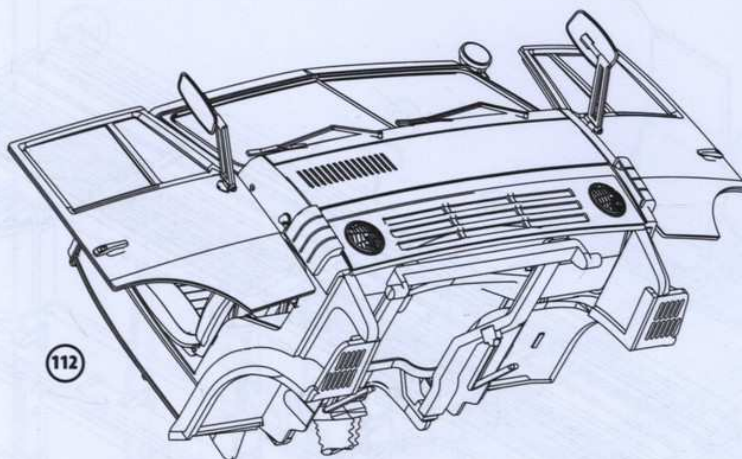

?

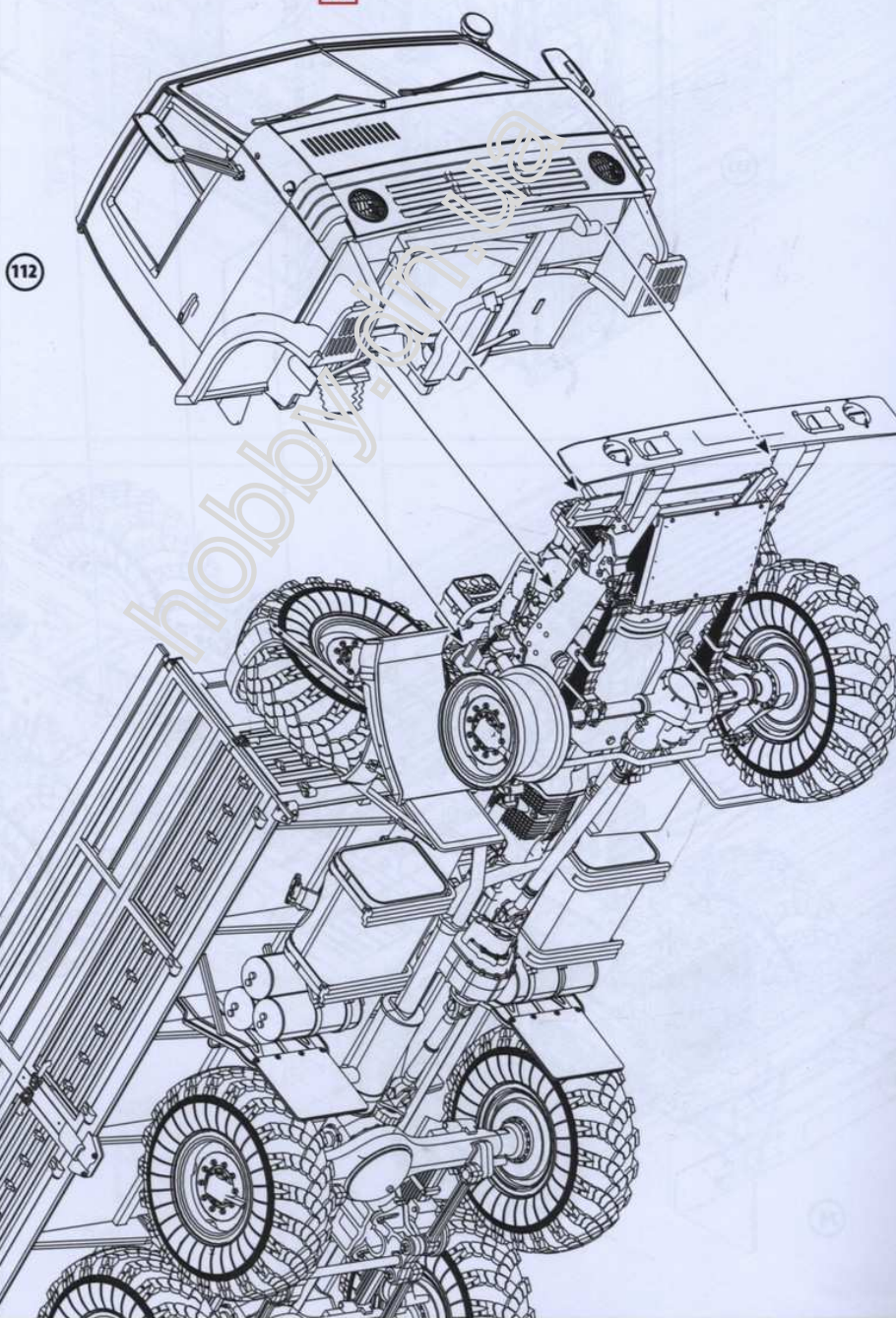

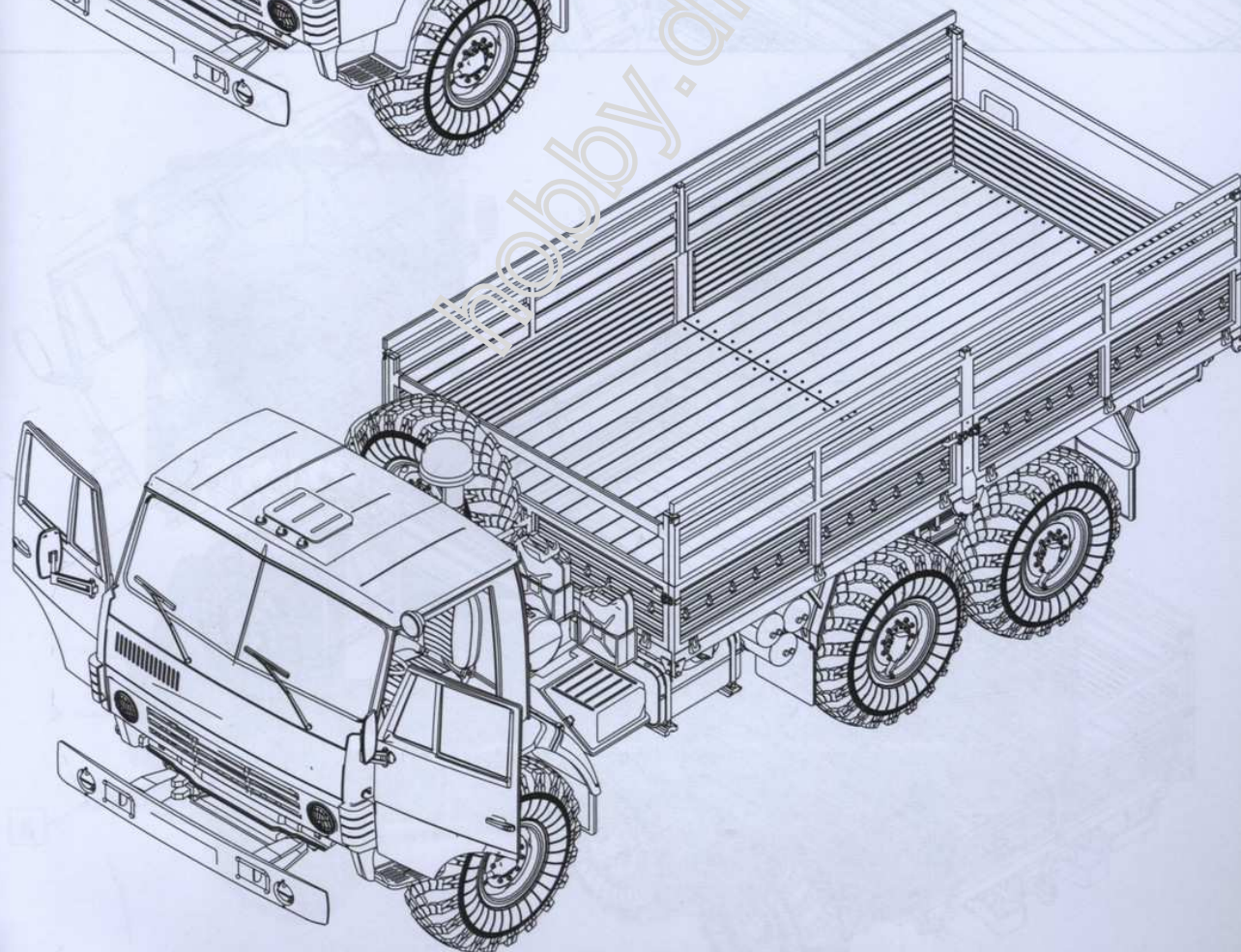
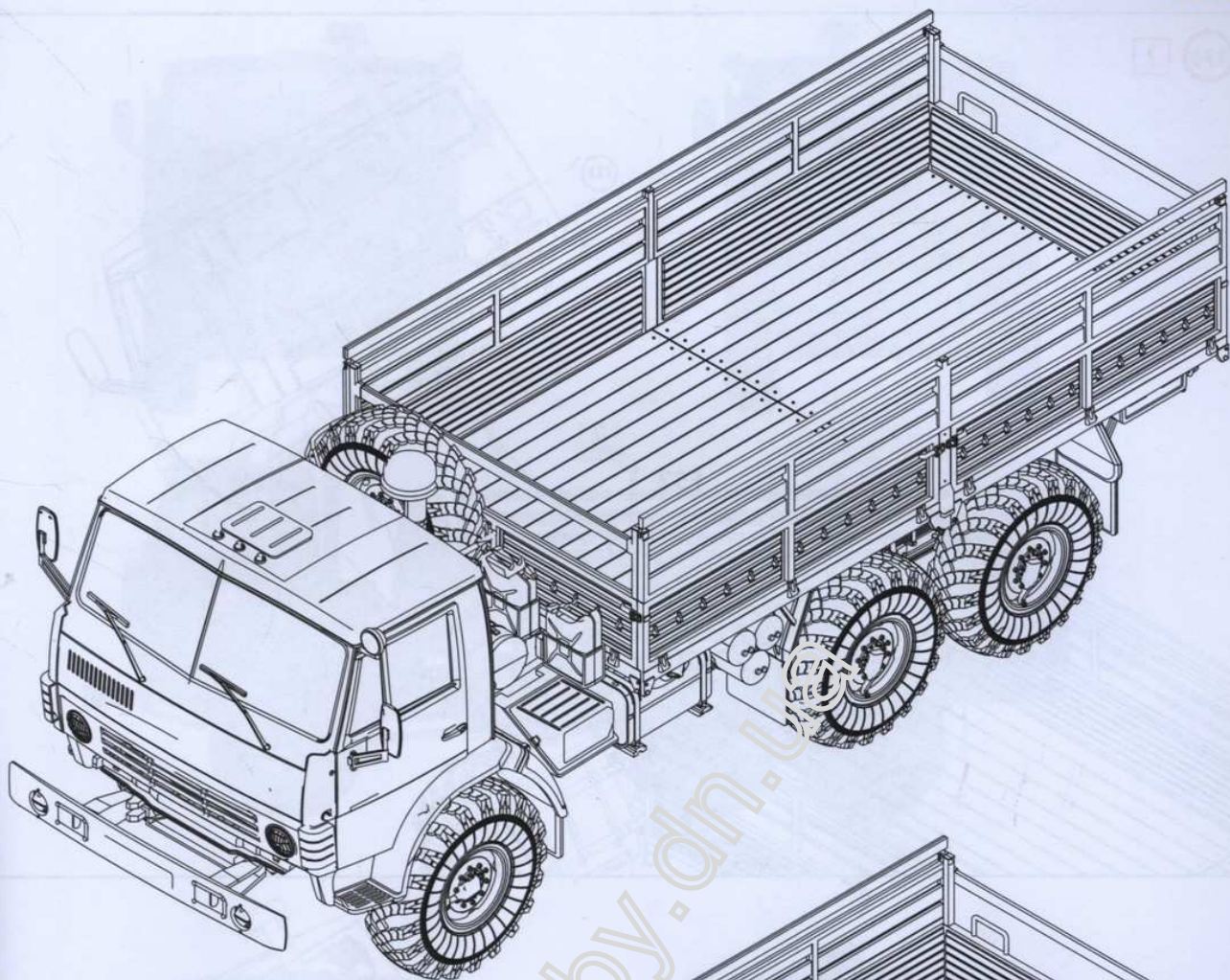

136 ?

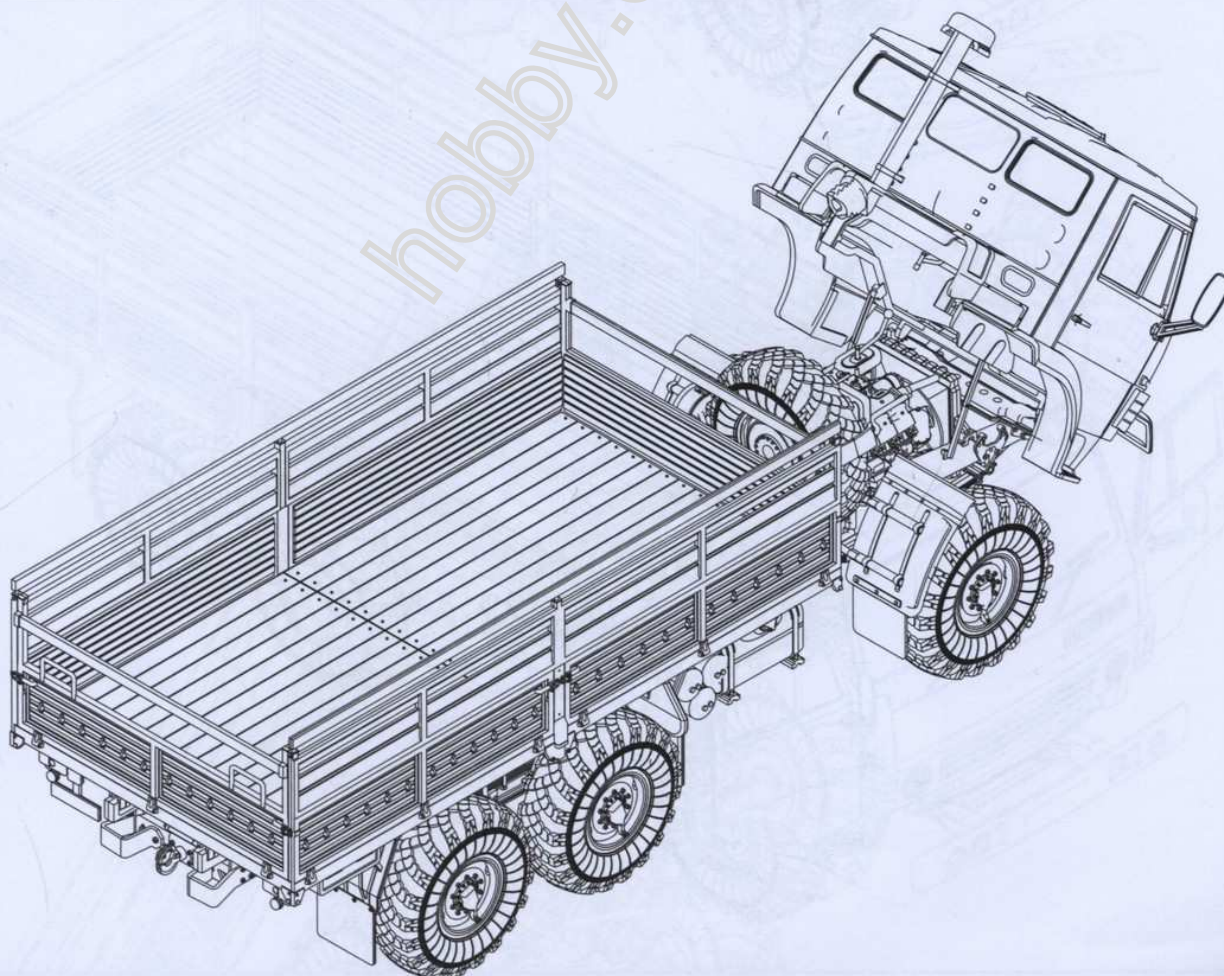
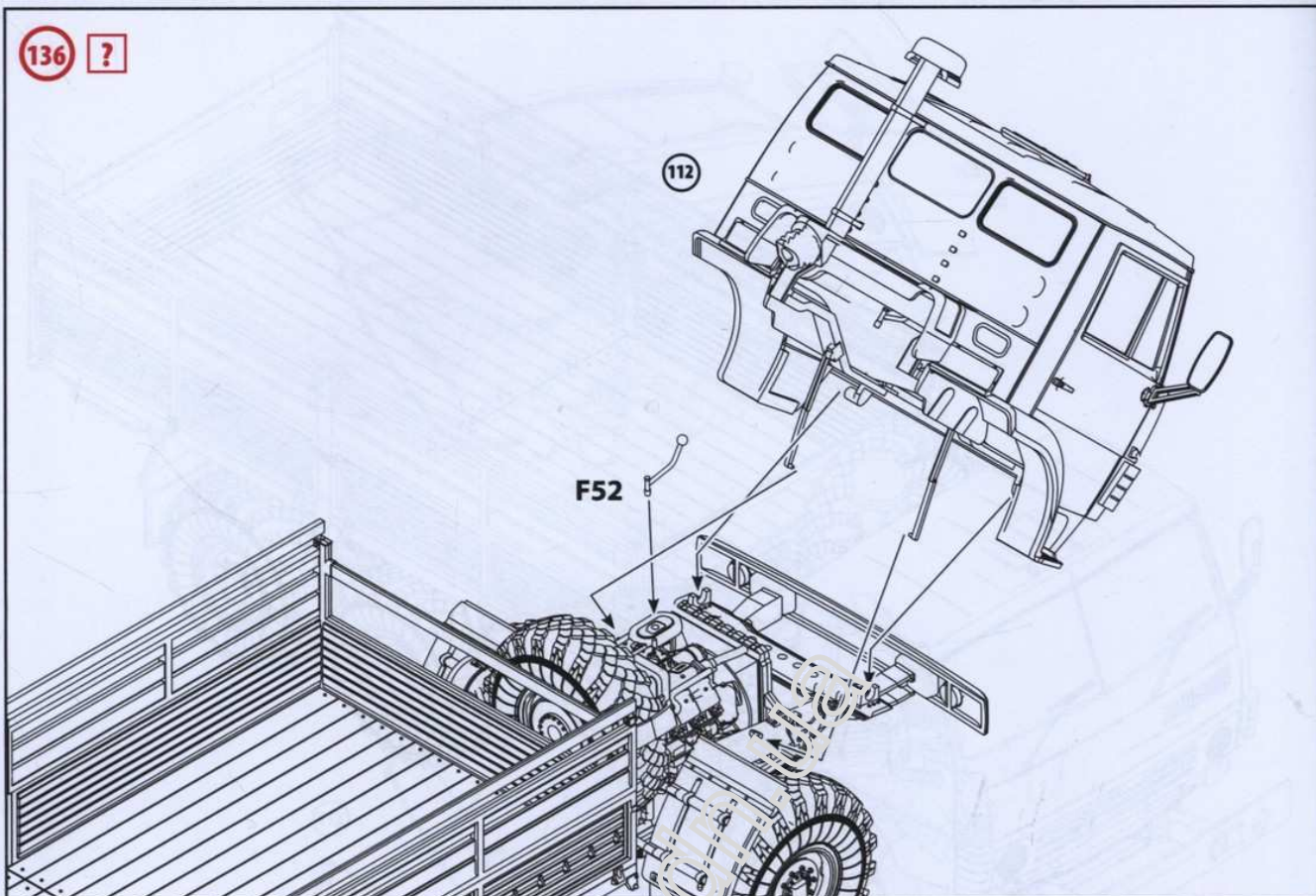

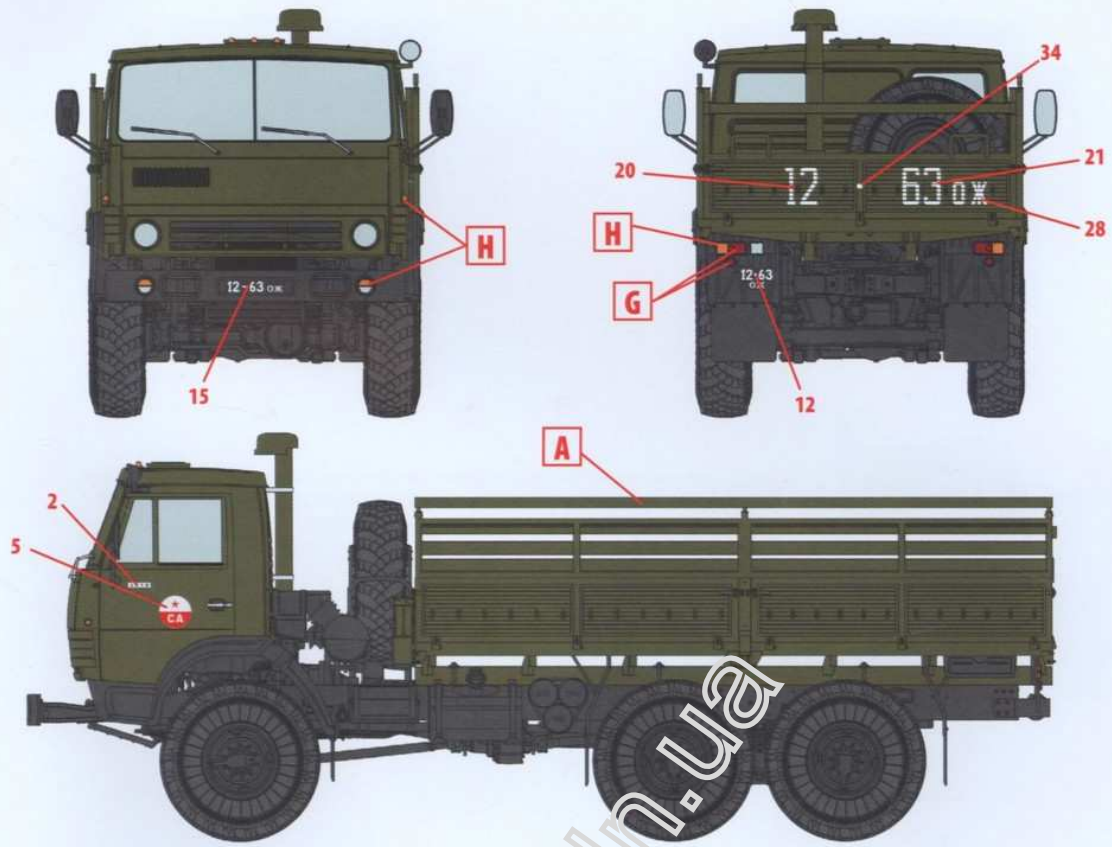

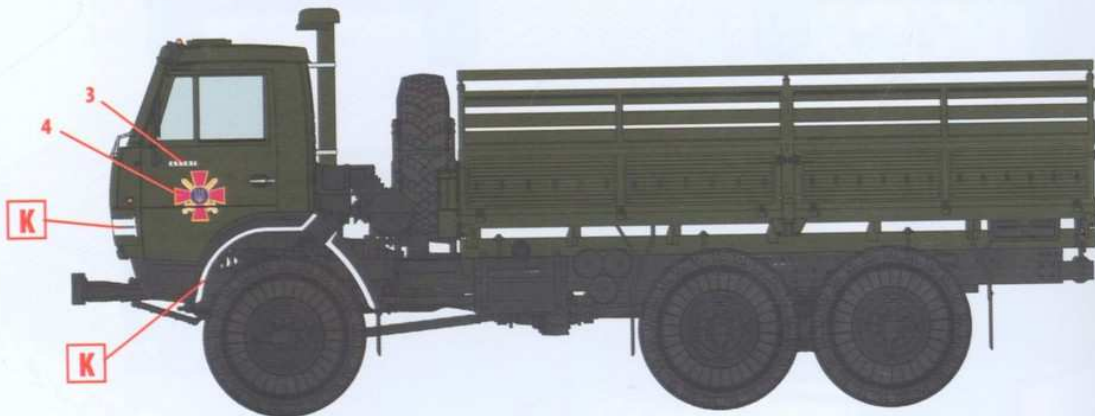
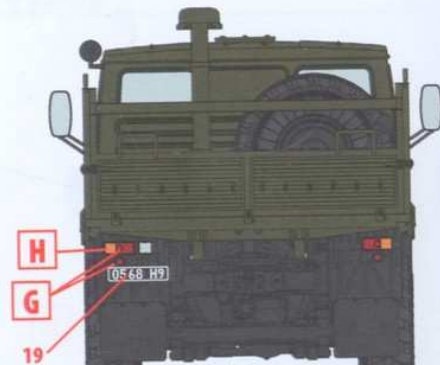
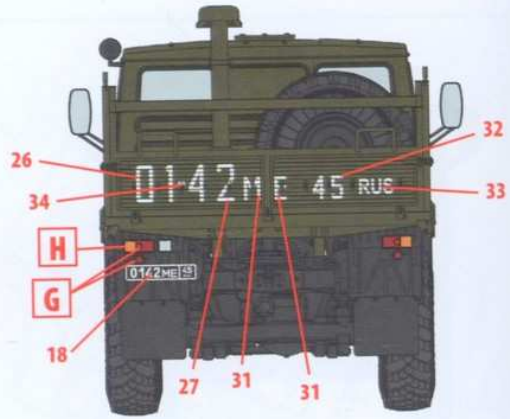

ООО ICM Холдинг
 ул. Бориспольская 9, строение 64,
 02099, Киев, Украина
 Тел./факс: +38(044) 369 54 12
 E-mail: export@icm.com.ua