



Ju 88D-1

Германский самолет-разведчик II MB

В начале 30-х годов в мире возникла идея создания скоростного бомбардировщика, который мог бы обогнать современные ему истребители-бипланы. Одним из воплощений этой концепции стал двухмоторный бомбардировщик Ju 88, разработанный германской фирмой Юнкерс Флюгzeug- und Motorenwerke AG.

С весны 1941 г. началось производство самолетов Ju 88A-4 с усиленным вооружением, на которых были установлены двигатели жидкостного охлаждения Jumo 211J увеличенной мощности.

На базе Ju 88A-4 строились дальние самолеты-разведчики, получившие обозначение Ju 88D-1.

Тактико-технические характеристики Ju 88D-1

| | |
|-----------------------------|---|
| Длина, м | 14,36 |
| Размах крыла, м | 20,08 |
| Взлетный вес, кг | 14000 |
| Двигатель | 2xJumo 211J, 1400 л.с. |
| Максимальная скорость, км/ч | 467 |
| Потолок, м | 8500 |
| Дальность, км | 2500 |
| Вооружение | 4x7,92-мм пулемета MG 81, до 2900 кг бомб |

ВНИМАНИЕ!

Перед сборкой внимательно прочитайте руководство по монтажу каждой детали. Каждая деталь пронумерована. Соблюдать последовательность монтажа. Необходимые рабочие инструменты: нож и напильник для зачистки деталей; резиновая лента, клейкая лента и щетки для сушки белья для прижимания склеиваемых деталей. Детали из пластика очистить в растворе мягкого моющего средства и высушить на воздухе для того, чтобы краска и переводные картинки лучше прилипали. Перед приклеиванием проверить, подходят ли детали; клей наносить аккуратно. Хром и краску удалить с поверхностей склеивания. Небольшие детали покрасить перед тем, как они будут удалены из рамок. Краску необходимо хорошо просушить, только после этого продолжать сборку. Каждую соответствующую переводную картинку отделить от выкройки и приклеить на 20 секунд окунуть в теплую воду. На обозначенном месте картинку отделить от выкройки и приклеить промокательной бумагой.

ИСПОЛЬЗУЕМЫЕ КРАСКИ / USED COLORS:

| | Revell | Tamiya | | |
|----------|--------|--------|----------------------|-------------------|
| A | 108 | XF1 | Черный, матовый | Flat Black |
| B | 105 | XF2 | Белый, матовый | Flat White |
| C | 115 | XF3 | Желтый, матовый | Flat Yellow |
| D | 140 | XF27 | Черно-зеленый RLM 70 | Schwarzgrun RLM70 |
| E | 139 | XF61 | Темно-зеленый RLM71 | Dunkelgrun RLM71 |
| F | 149 | XF23 | Голубой RLM65 | Hellblau RLM65 |
| G | 177 | XF84 | Черно-серый, матовый | Schwarzgrau RLM66 |

Ju 88D-1

WWII German Reconnaissance Plane

In the beginning of 30s it was appeared in the world an idea of high-speed bomber that could outstrip contemporary fighters. One of the objectifications of this conception became the twin-engine bomber Ju 88 designed by a German Junkers Flugzeug- und Motorenwerke AG company.

Since the spring of 1941 it were produced Ju 88A-4 planes with liquid-cooled Jumo 211J engines of increased power and more powerful armament.

On the basis of Ju 88A-4 built long-range reconnaissance aircraft, designated Ju 88D-1.

Tactical and Technical Specifications of Ju 88D-1

| | |
|--------------------|--|
| Length, m | 14,36 |
| Span, m | 20,08 |
| Start Weight, kg | 14000 |
| Engine | 2xJumo 211J, 1400 hp |
| Max. Speed, km/h | 467 |
| Service Ceiling, m | 8500 |
| Range, km | 2500 |
| Armament | 4x7,92 mm MG 81, bomb load - up to 2900 kg |

CAUTION!

Read the instructions thoroughly prior to assembly. Each component is numbered. Adhere to specified sequence of assembly. Tools required: knife and file for removal of components from frame; rubber bond, adhesive tape and clothes pegs for clamping components together after applying adhesive. Clean plastic components in a mild detergent solution and allow to air-dry so that paint and transfers adhere better. Prior to applying adhesive, check to see whether the components fit together; apply adhesive sparingly. Remove chrome and paint from the contact surfaces. Paint small components before removing them from the frame. Allow paint to dry well, and only then continue to assemble. Cut out each transfer individually and immerse in warm water for approx. 20 seconds. Slide transfer off paper and into designated position, then press on with blotting paper.

| | Revell | Tamiya | | |
|----------|--------|--------|-----------------------|--------------|
| H | 145 | XF22 | Серо-зеленый RLM02 | Grau RLM02 |
| J | 199 | XF16 | Алюминий, полуматовый | Aluminium |
| K | 191 | X11 | Сталь | Steel |
| L | 109 | X10 | Темный металл | Gun Metal |
| M | 183 | XF64 | Ржавчина | Rust |
| N | 330 | XF7 | Красный, матовый | Flat Red |
| P | 364 | XF26 | Зеленый, матовый | Flat Green |
| Q | 117 | XF59 | Темно-песочный | Africa Brown |

01 СТАДИЯ СБОРКИ
ASSEMBLY STEP

03 СБОРОЧНАЯ ЕДИНИЦА
ASSEMBLY UNIT

A ИСПОЛЬЗУЕМАЯ КРАСКА
USED COLOR

✘ НЕ КЛЕИТЬ
DO NOT CEMENT

x2 СДЕЛАТЬ ДВЕ ДЕТАЛИ
MAKE 2 PCS

■ ПРИ СБОРКЕ НЕ ИСПОЛЬЗУЕТСЯ
PARTS NOT FOR USE

□ ПРОСВЕРЛИТЬ
OPEN HOLE

▮ ОТРЕЗАТЬ
CUT OFF

***** СДЕЛАТЬ САМОМУ
SCRATCH BUILD

? ПРОИЗВОЛЬНЫЙ ВЫБОР
OPTIONAL

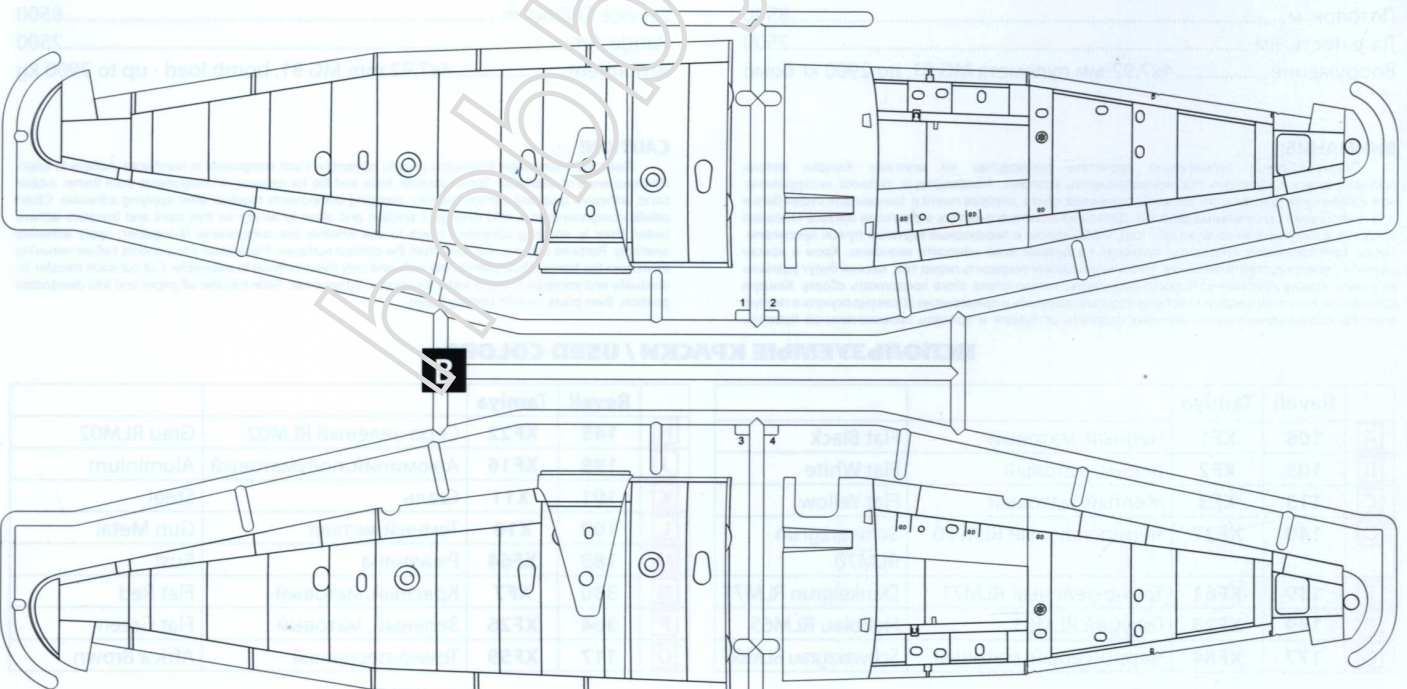
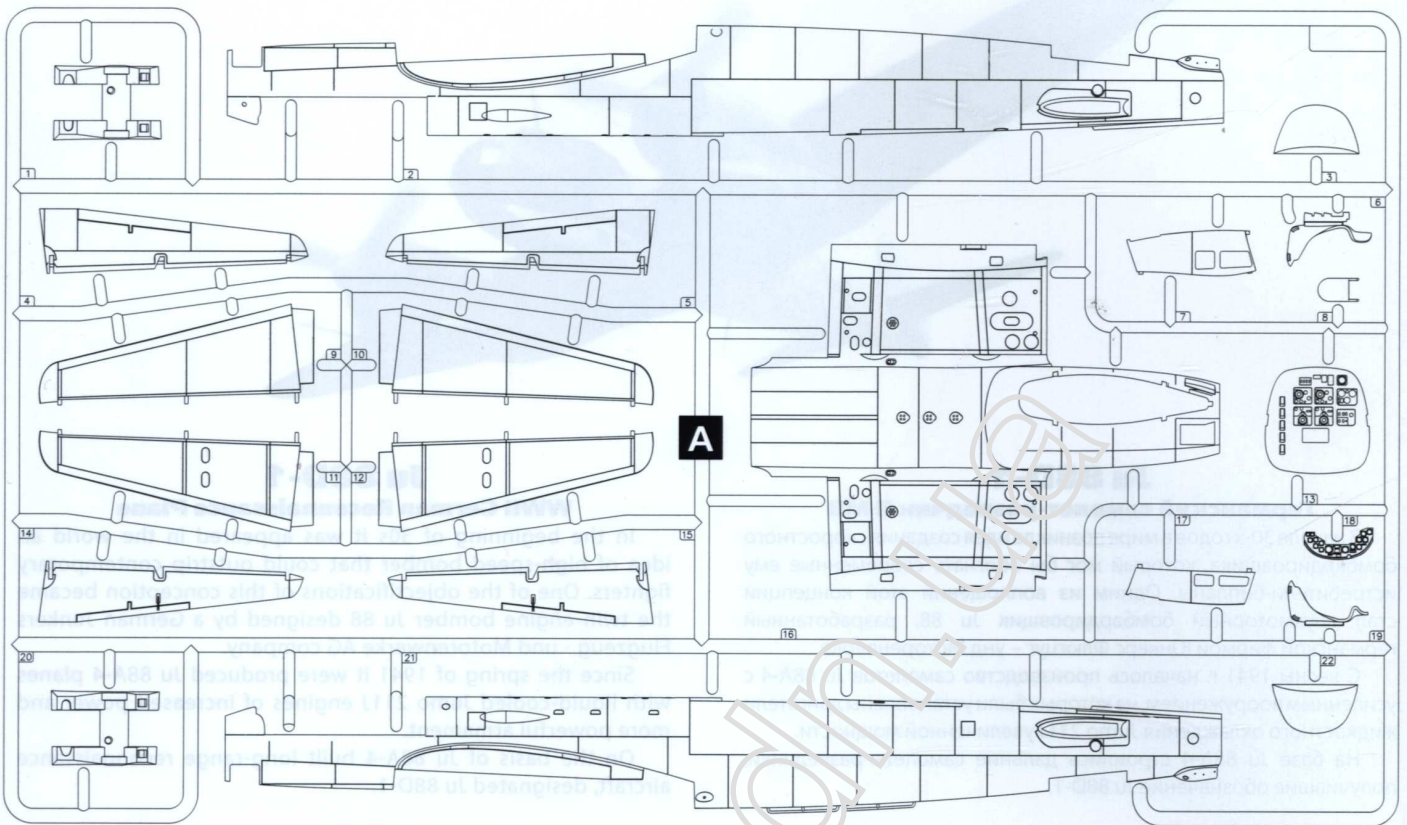

- | | | | |
|---------------|----------------------------------|--|----------------------------------|
| CUT OFF | OPEN HOLE | HE KRENTS DO NOT GLUE | ASSEMBLY STEP |
| SCRATCH BUILD | CREATAT DRE DETAIN MADE 3 PCS | TPN CROKE HE NCHOPAVETS PARTS NOT FOR USE | CPOH HAN EBNHMA ASSEMBLY UNIT |
| OPTIONAL | IPONBOPIPHN BPIOP | IPONBOPIPHN BPIOP | IPONBOPIPHN BPIOP |

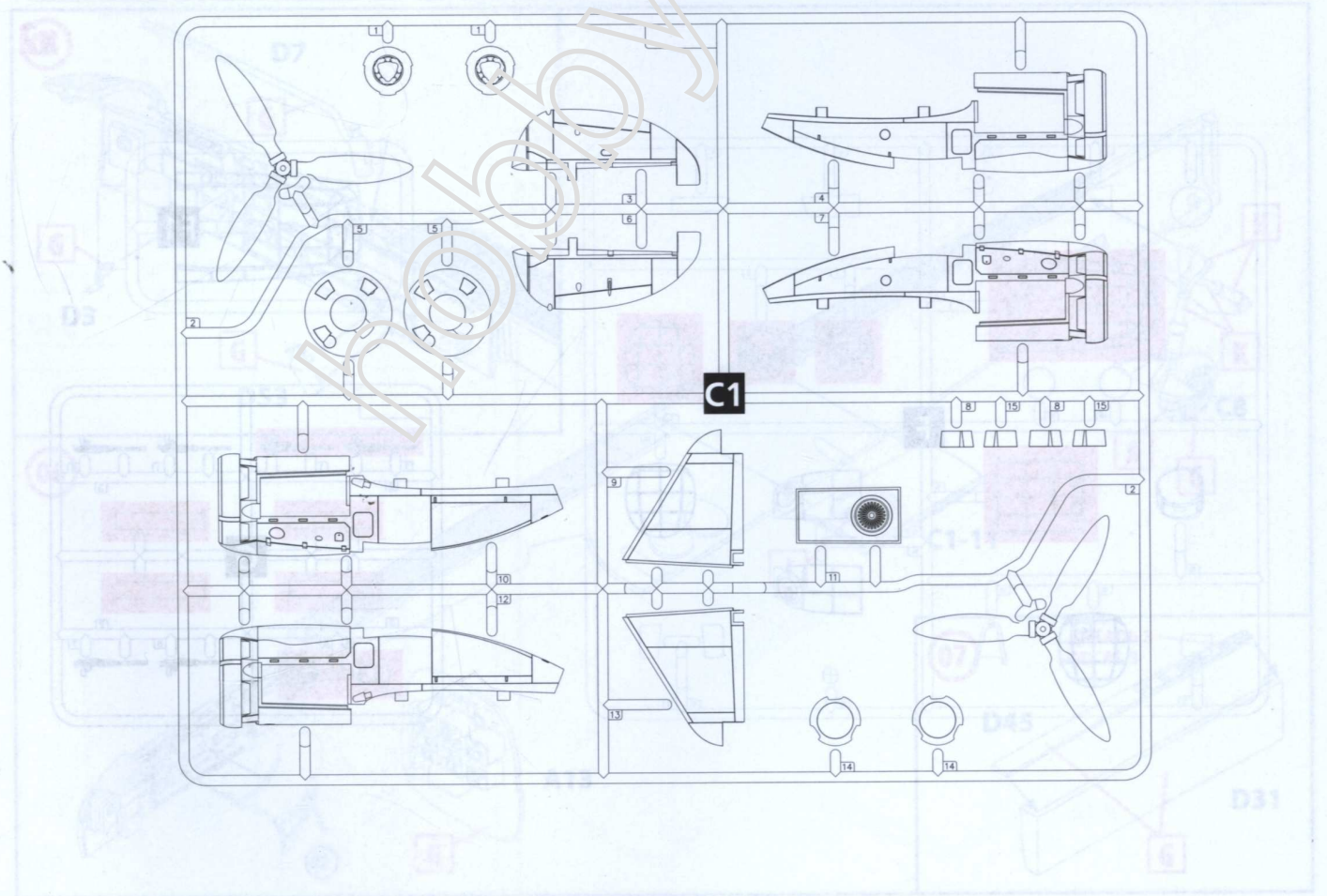
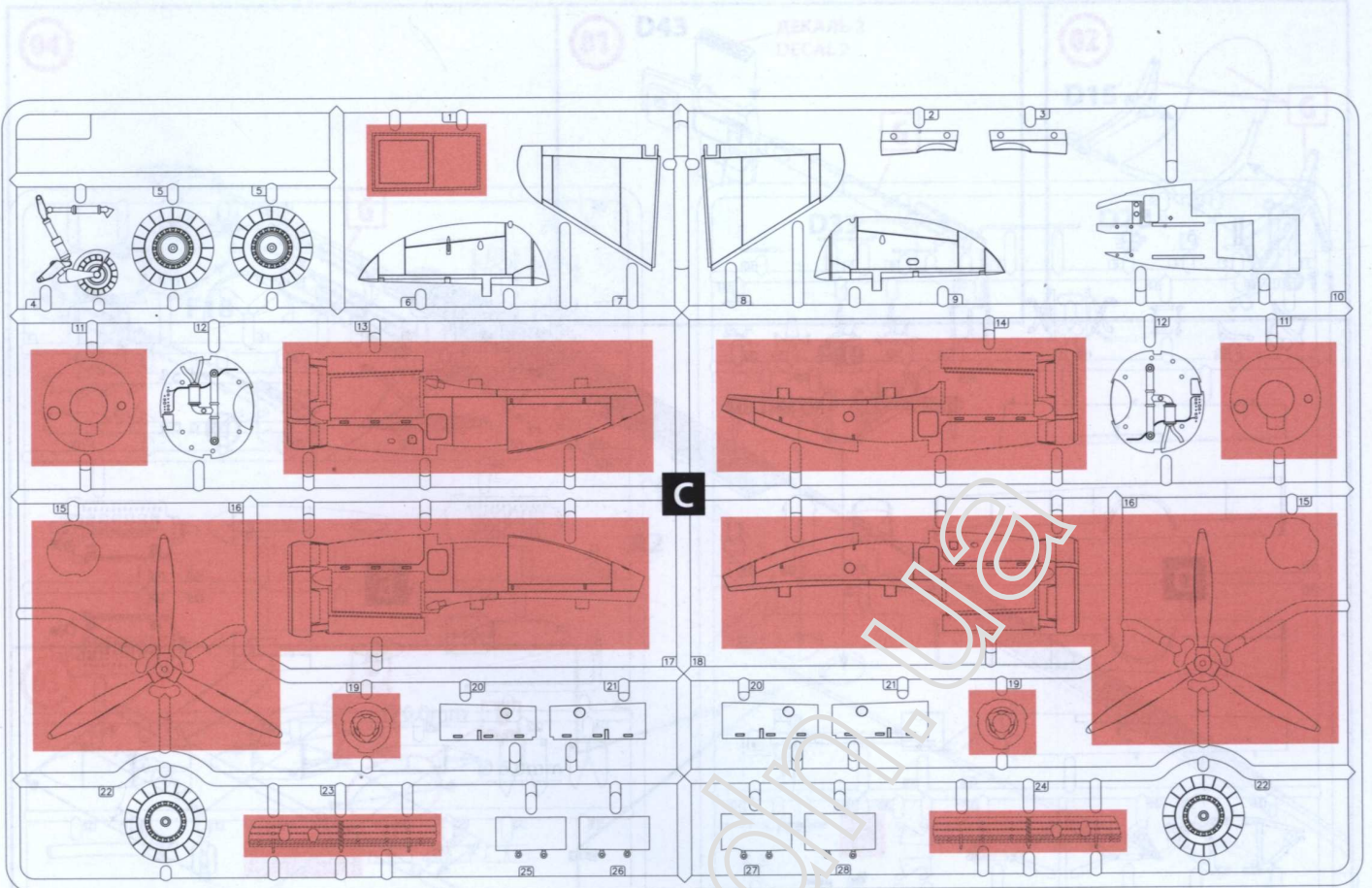

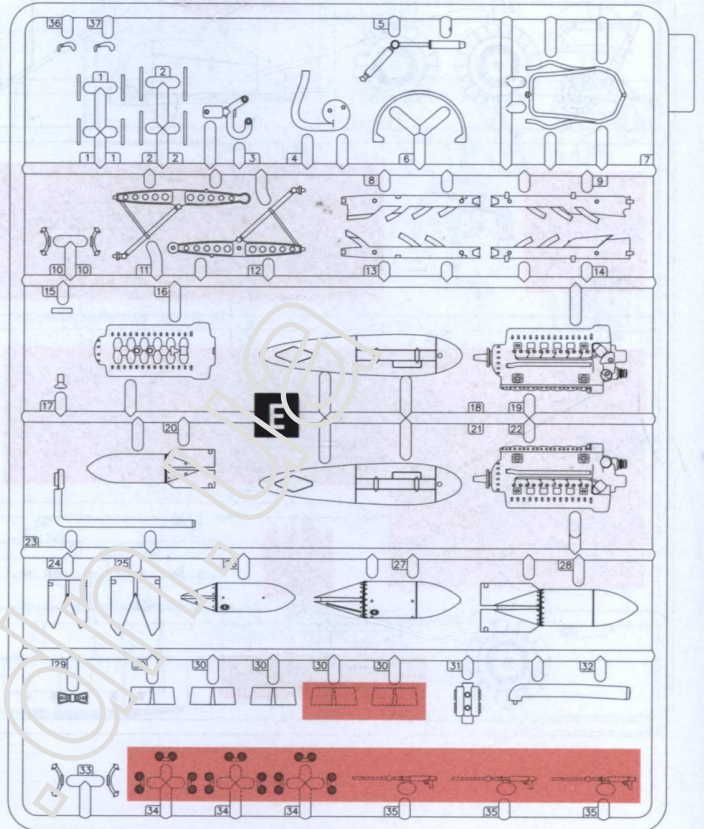
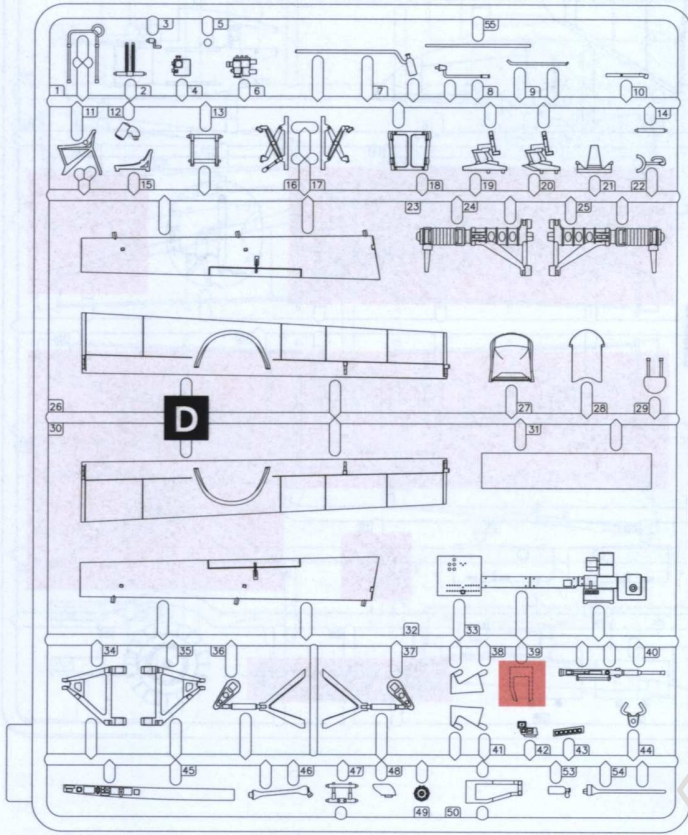

x2

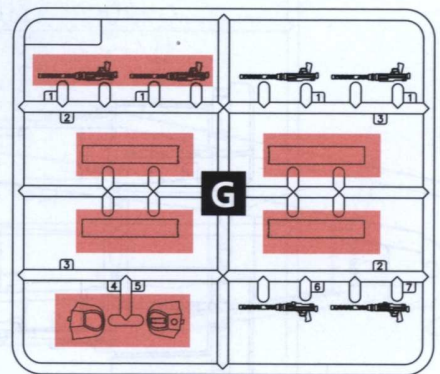
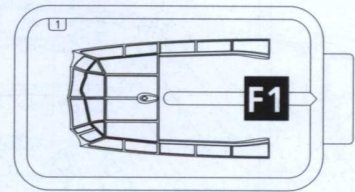
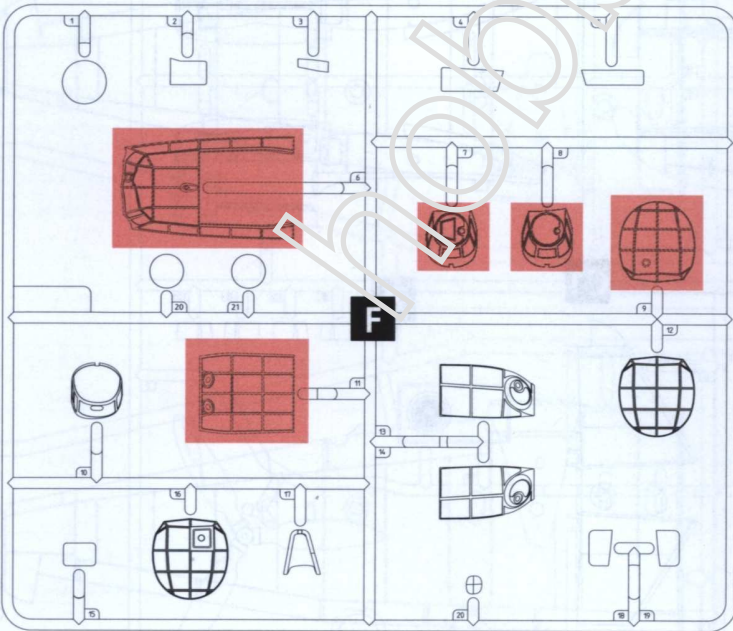

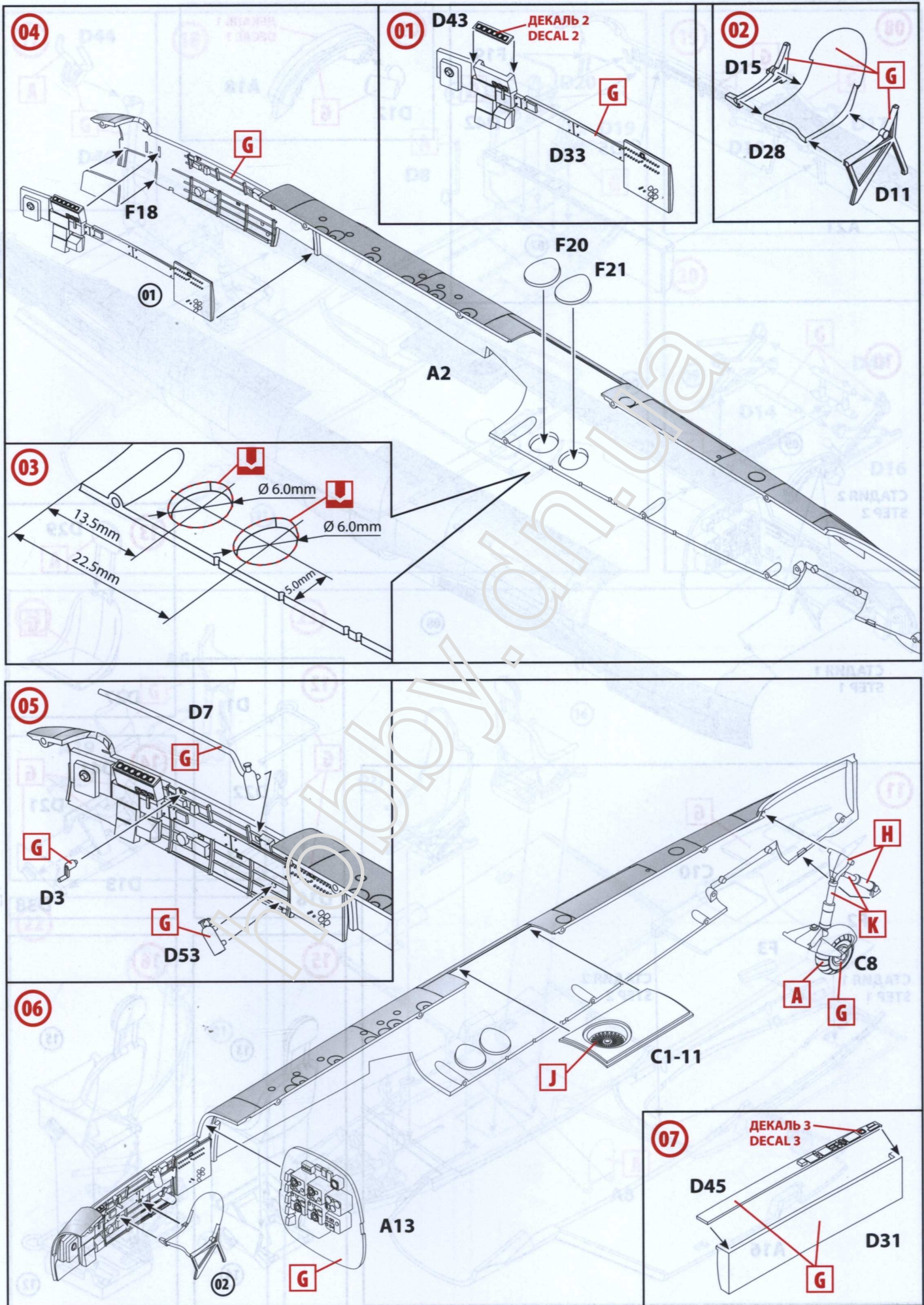

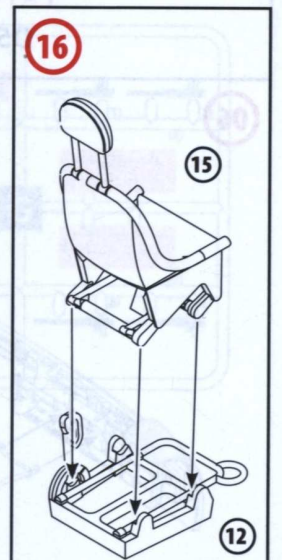
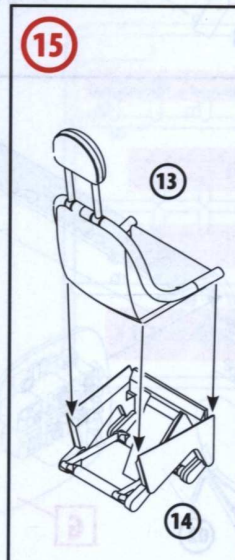
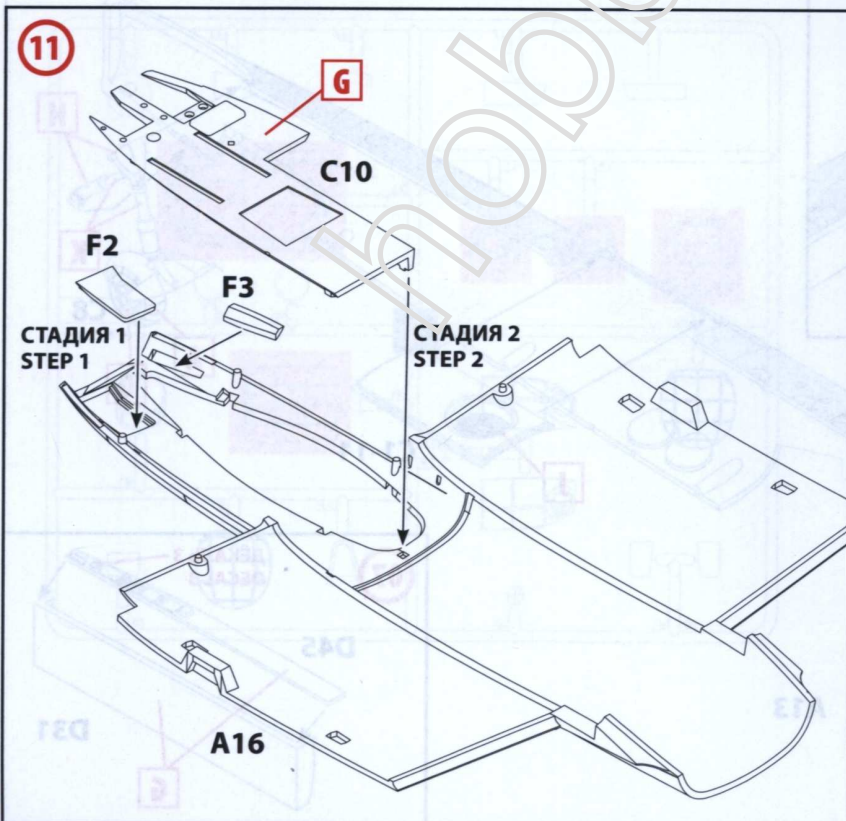
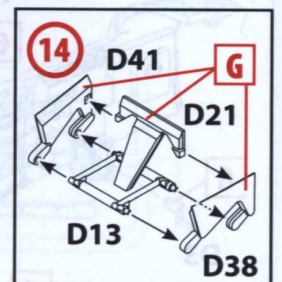
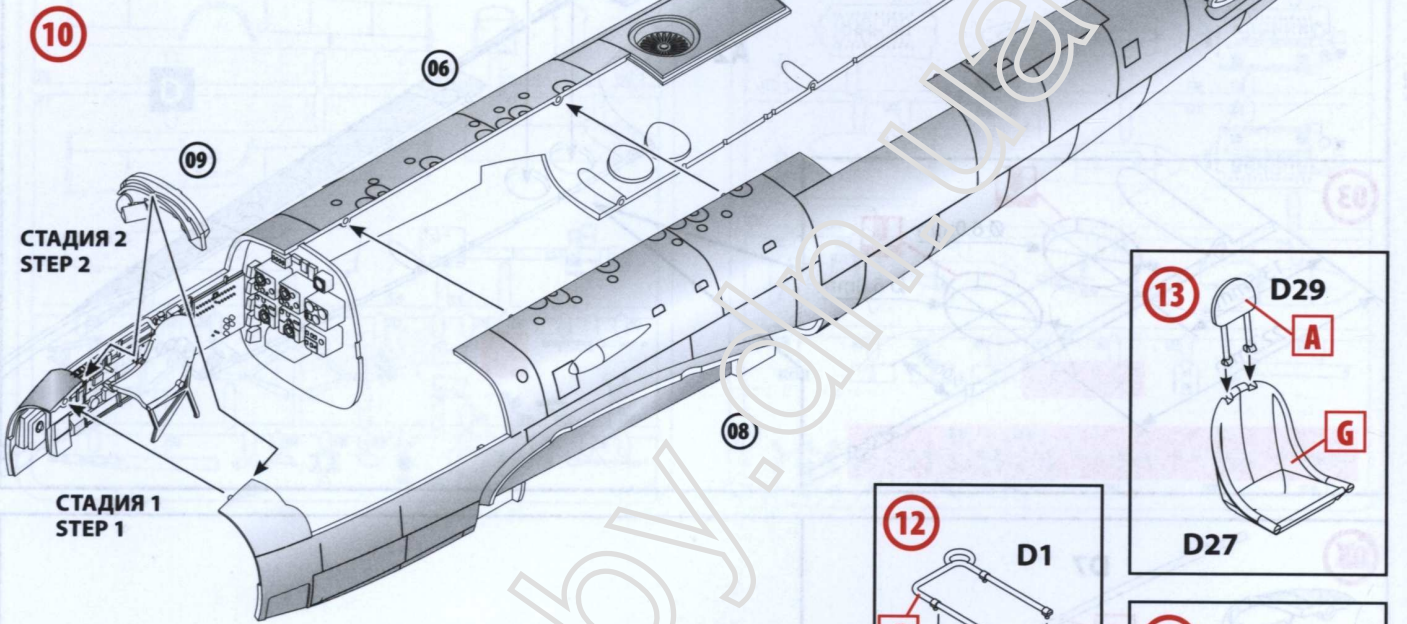
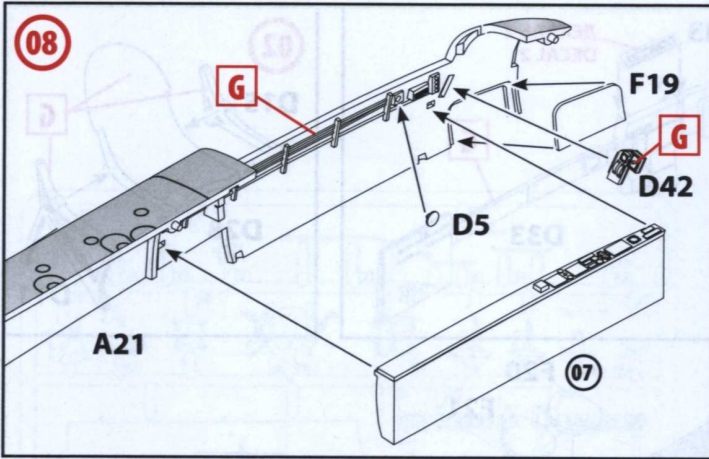

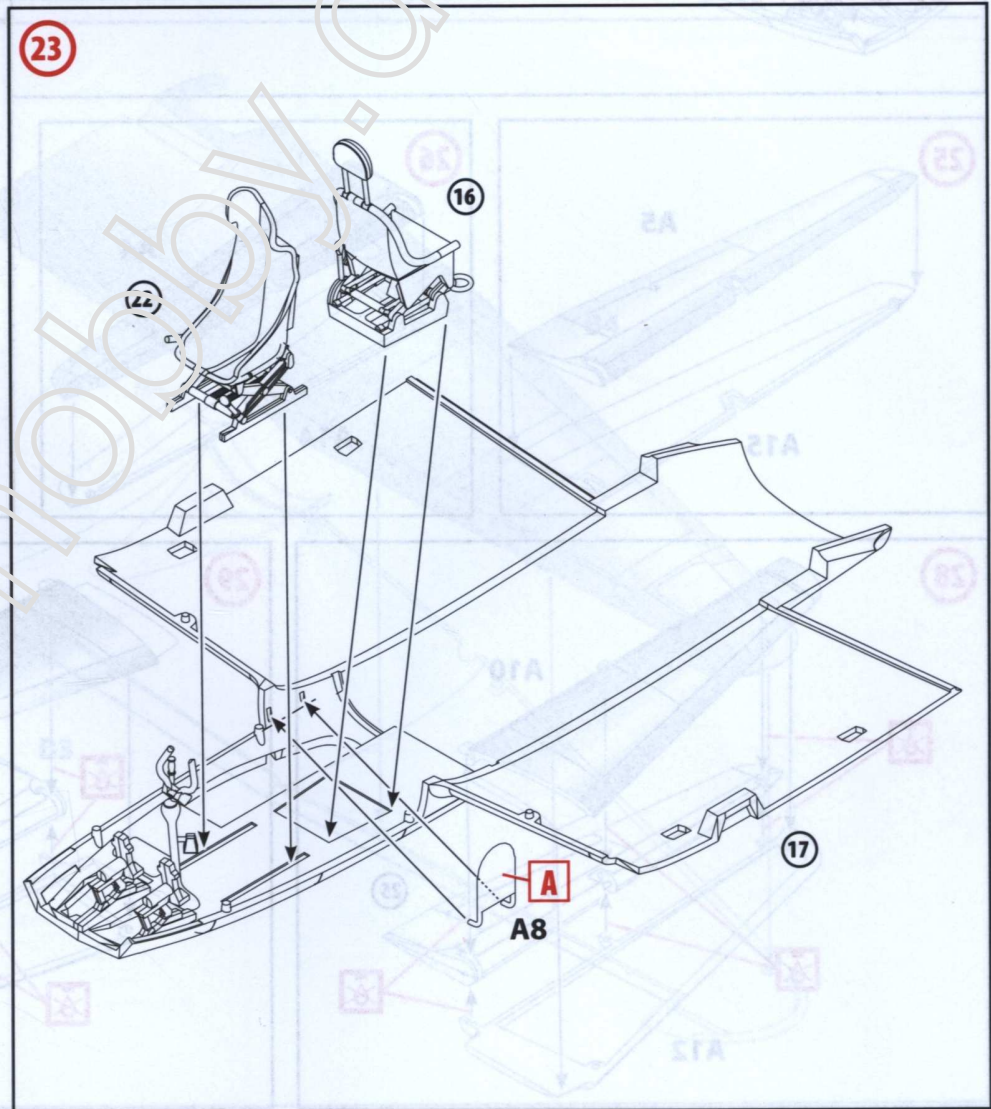
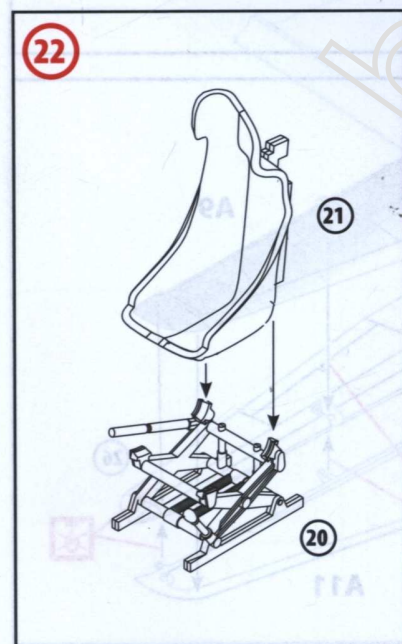
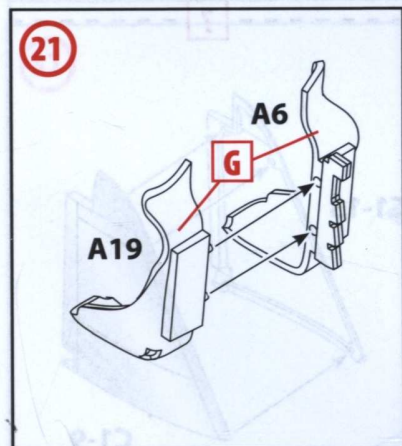
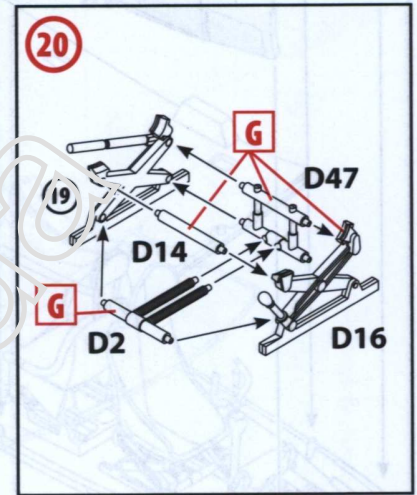
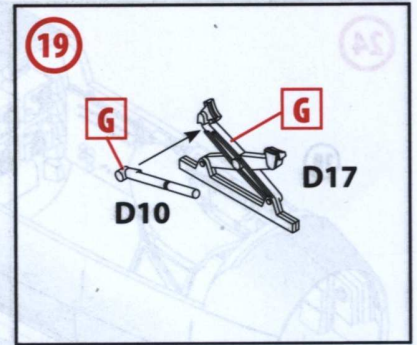
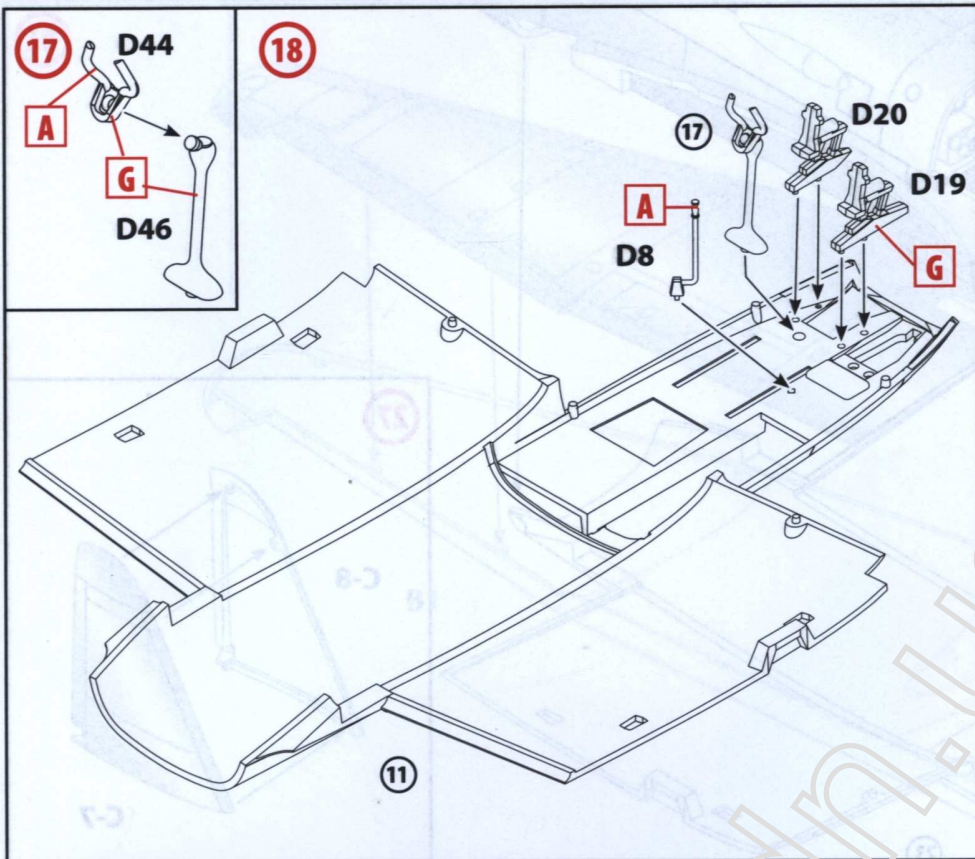

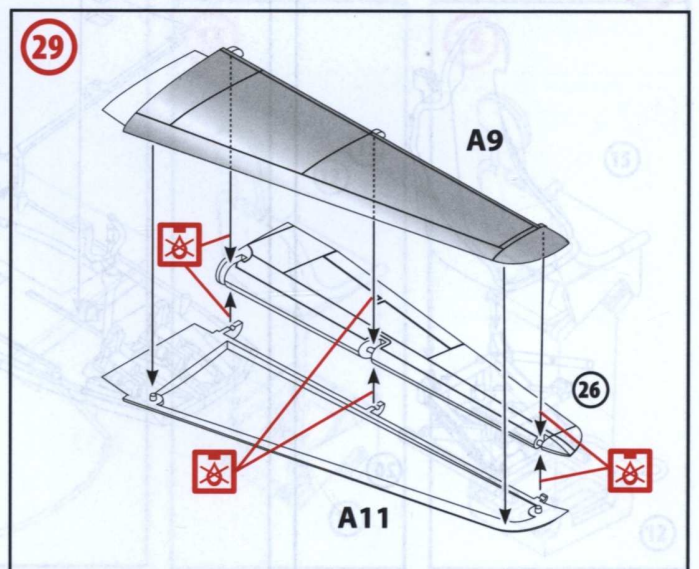
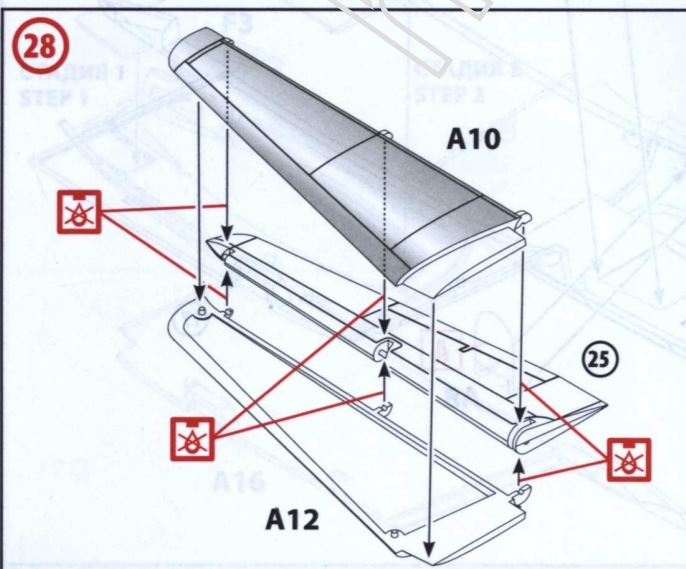
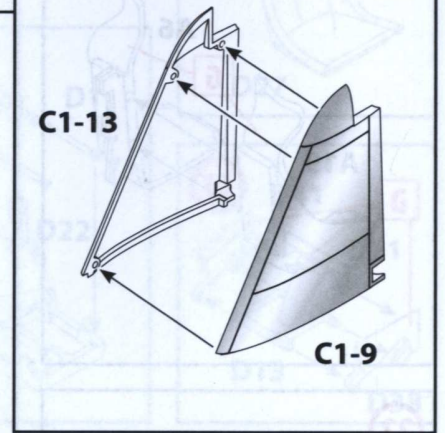
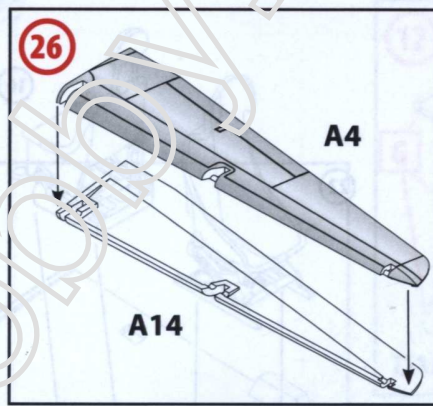
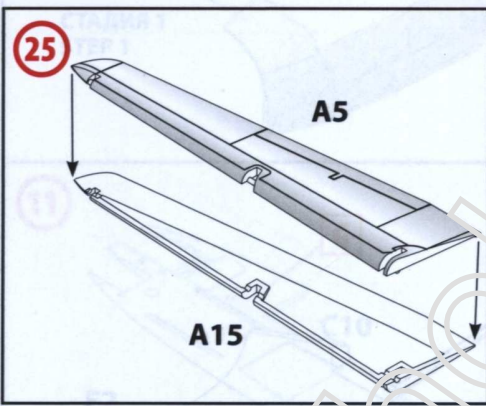
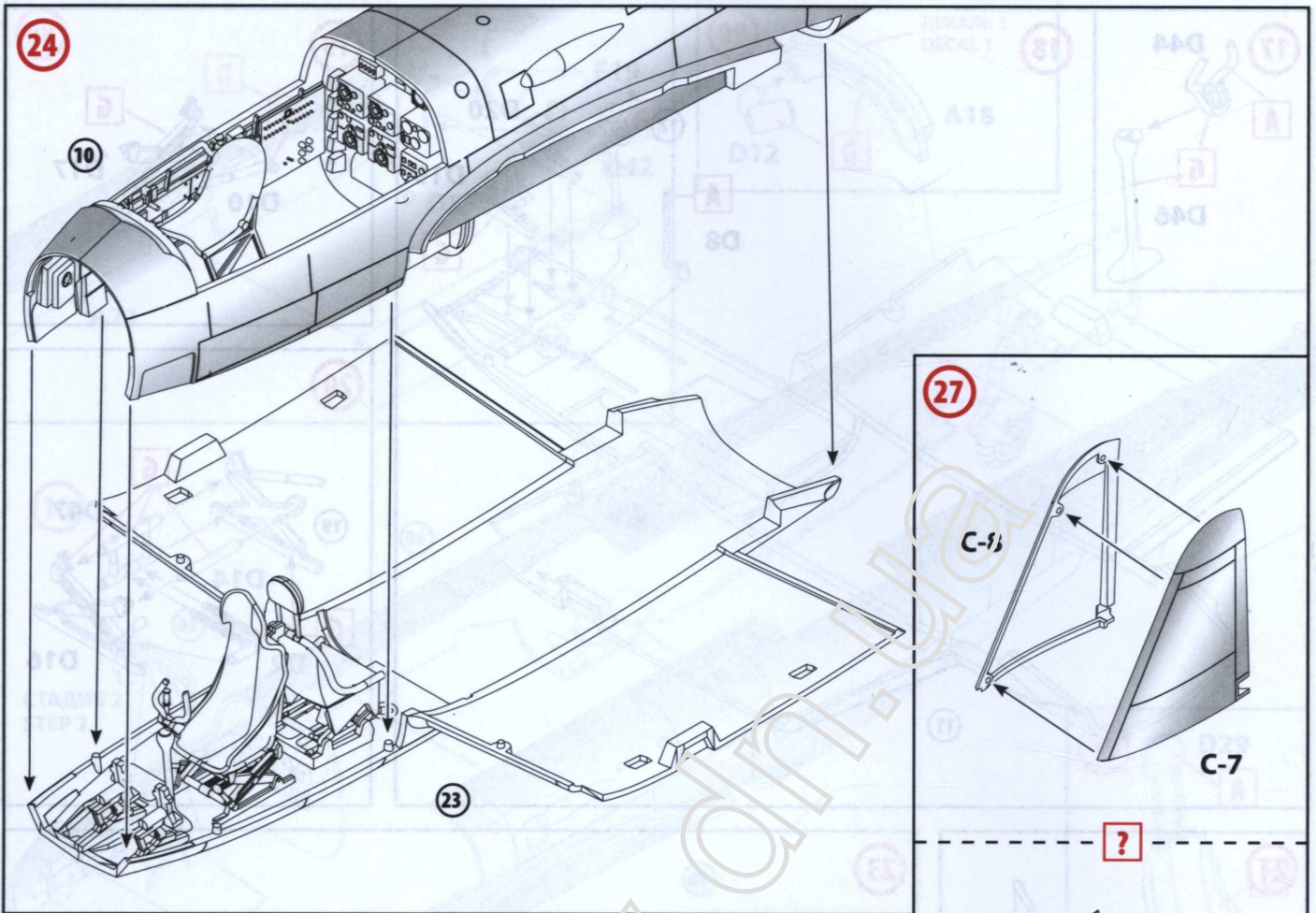

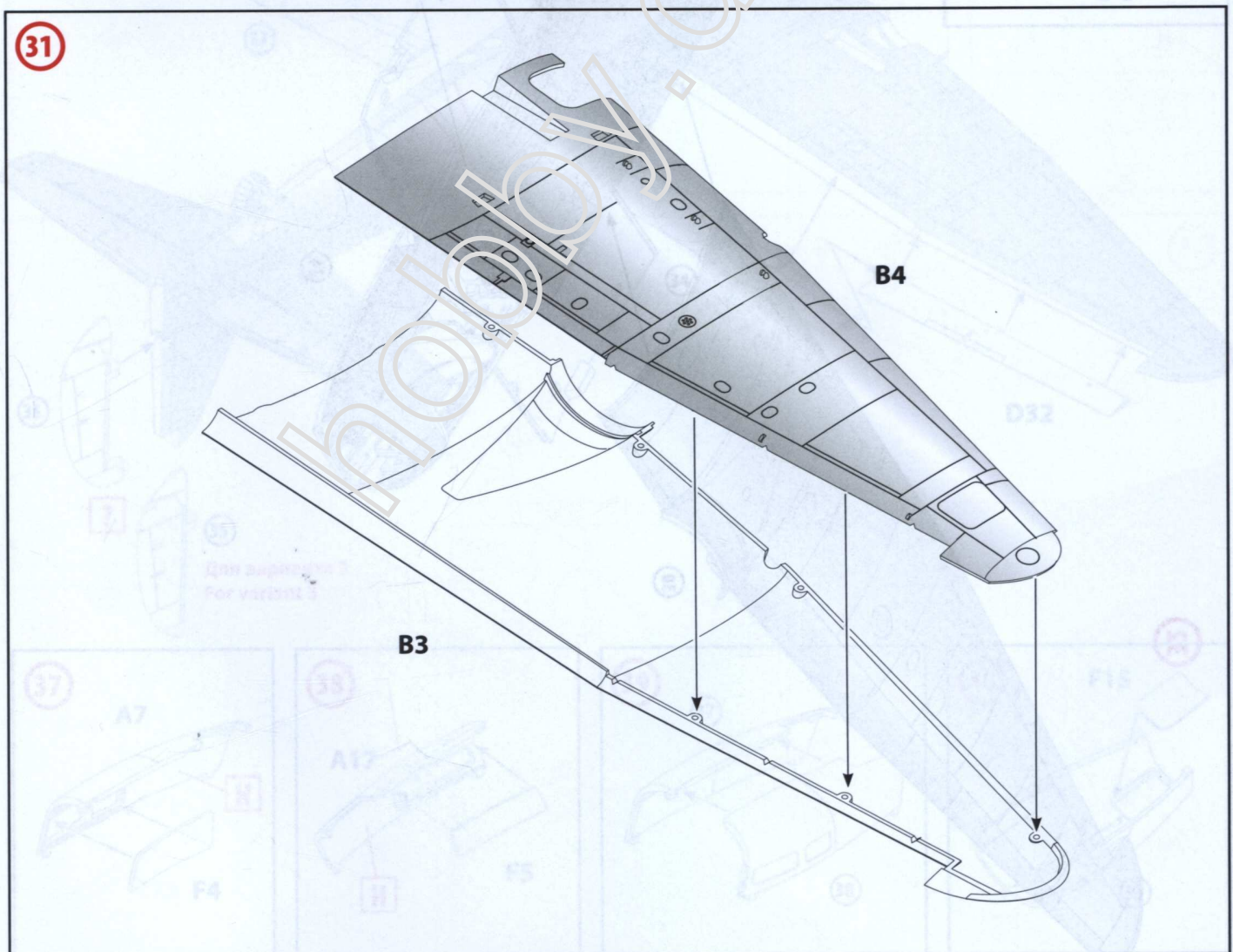
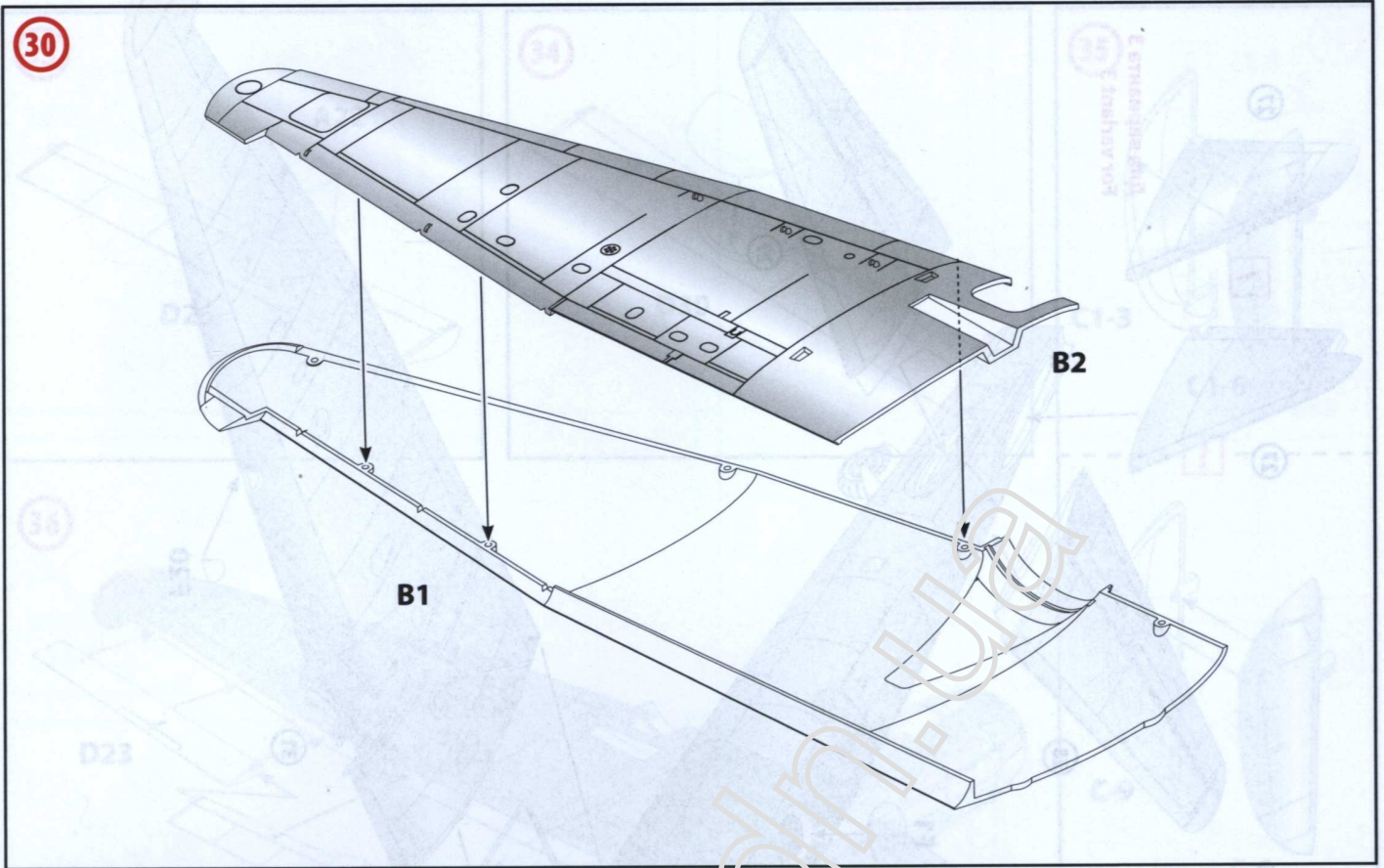

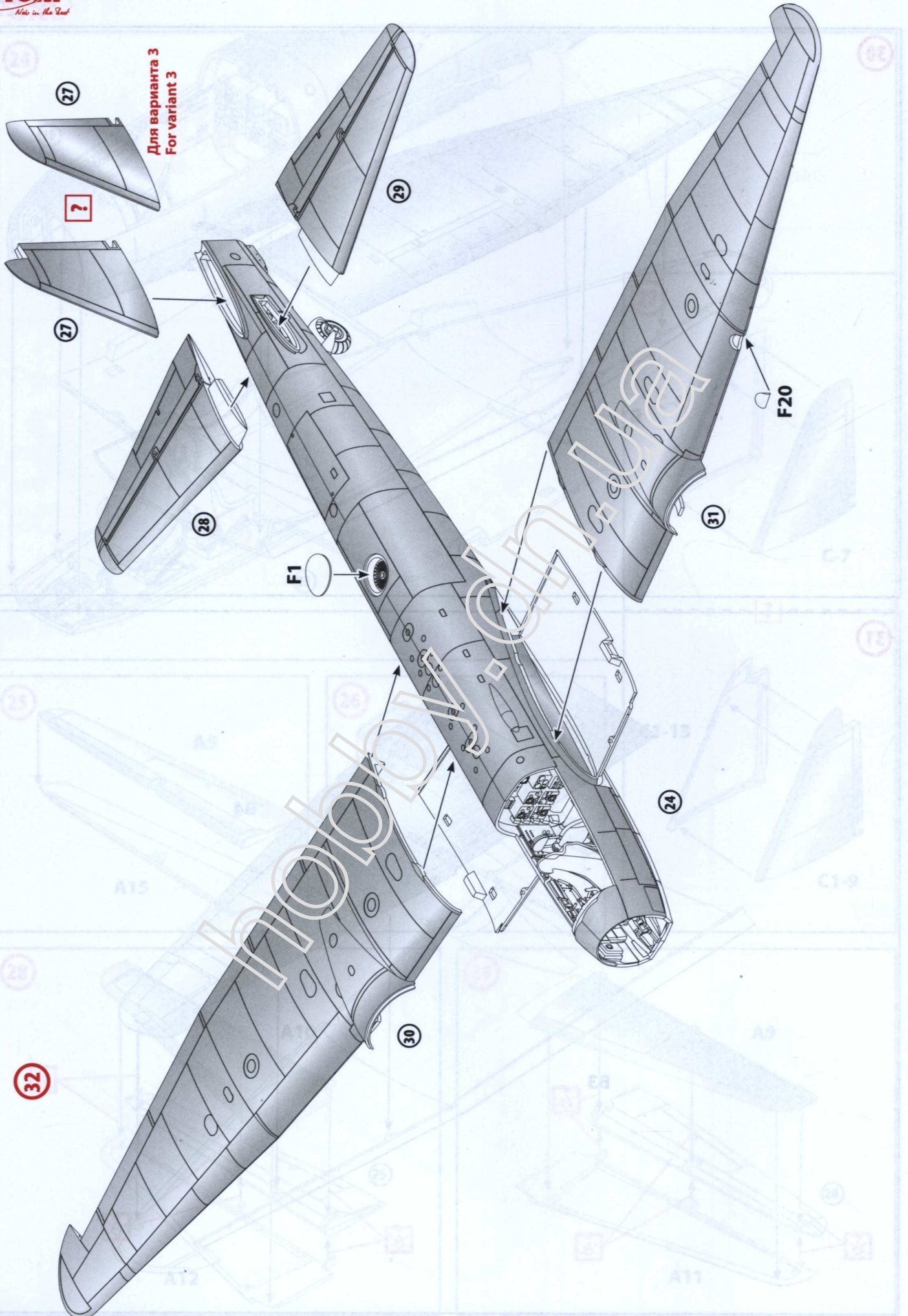

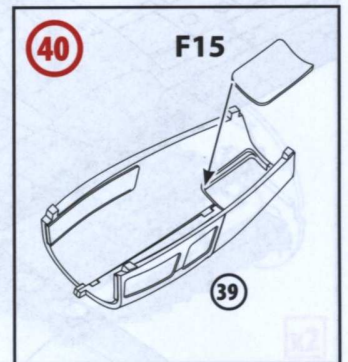
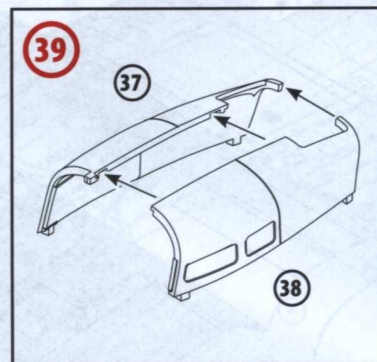
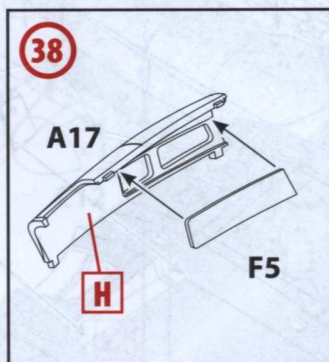
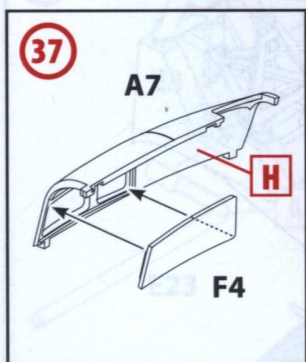
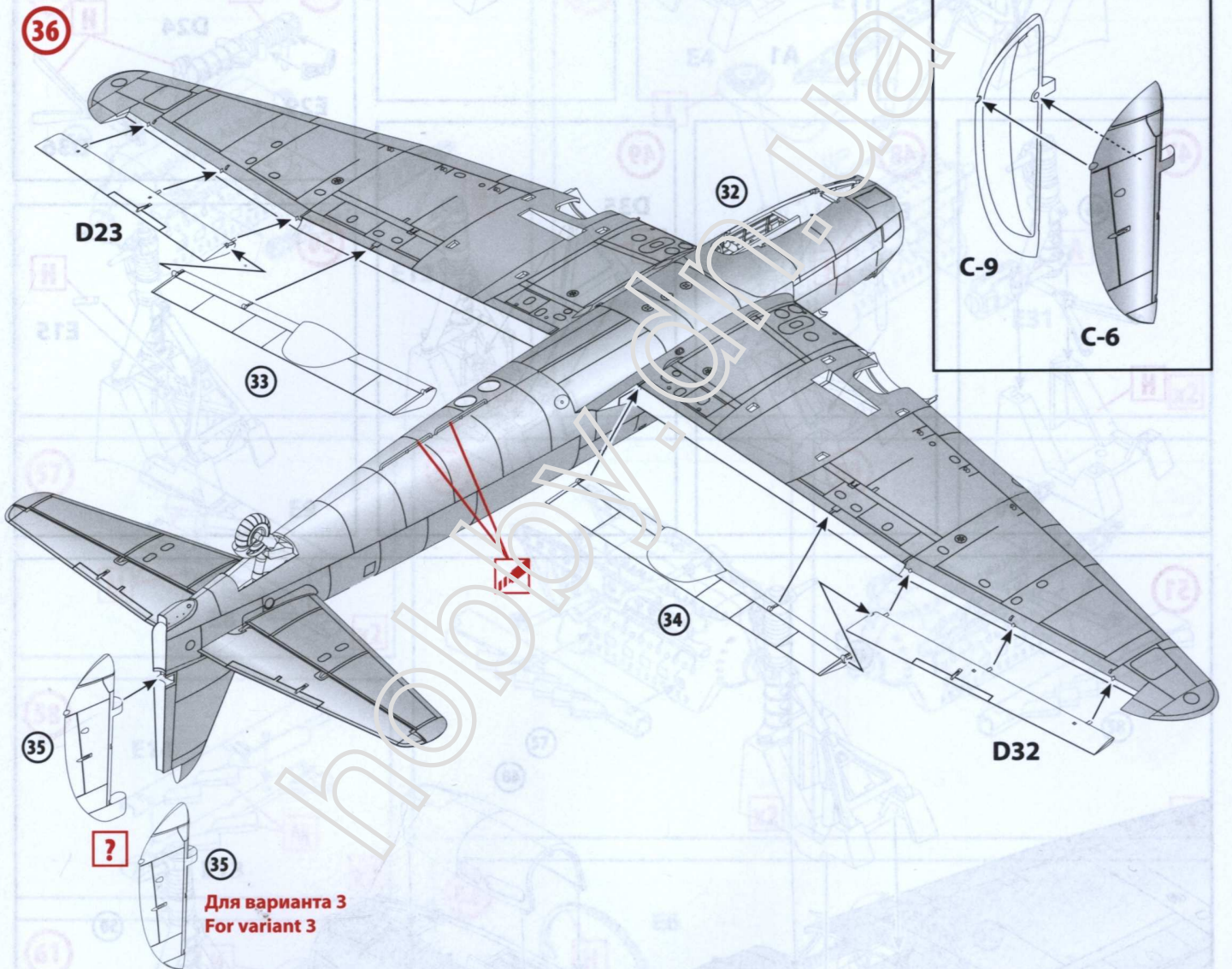
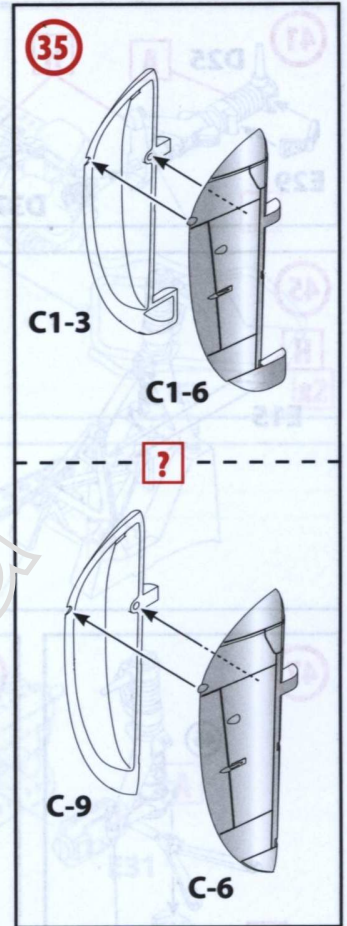
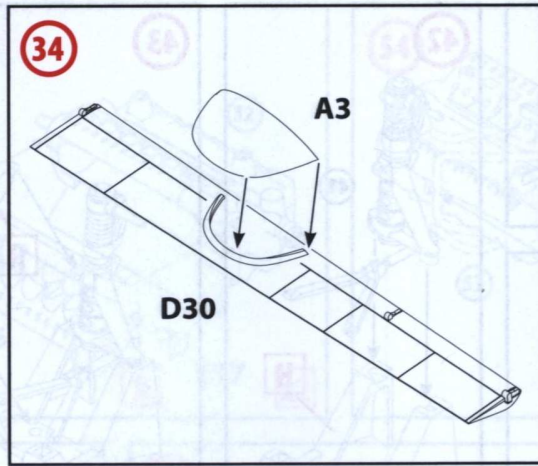
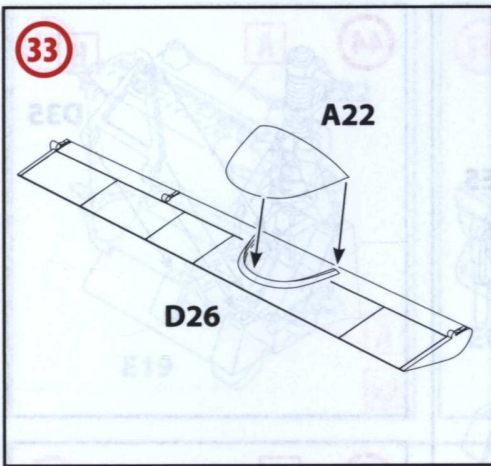

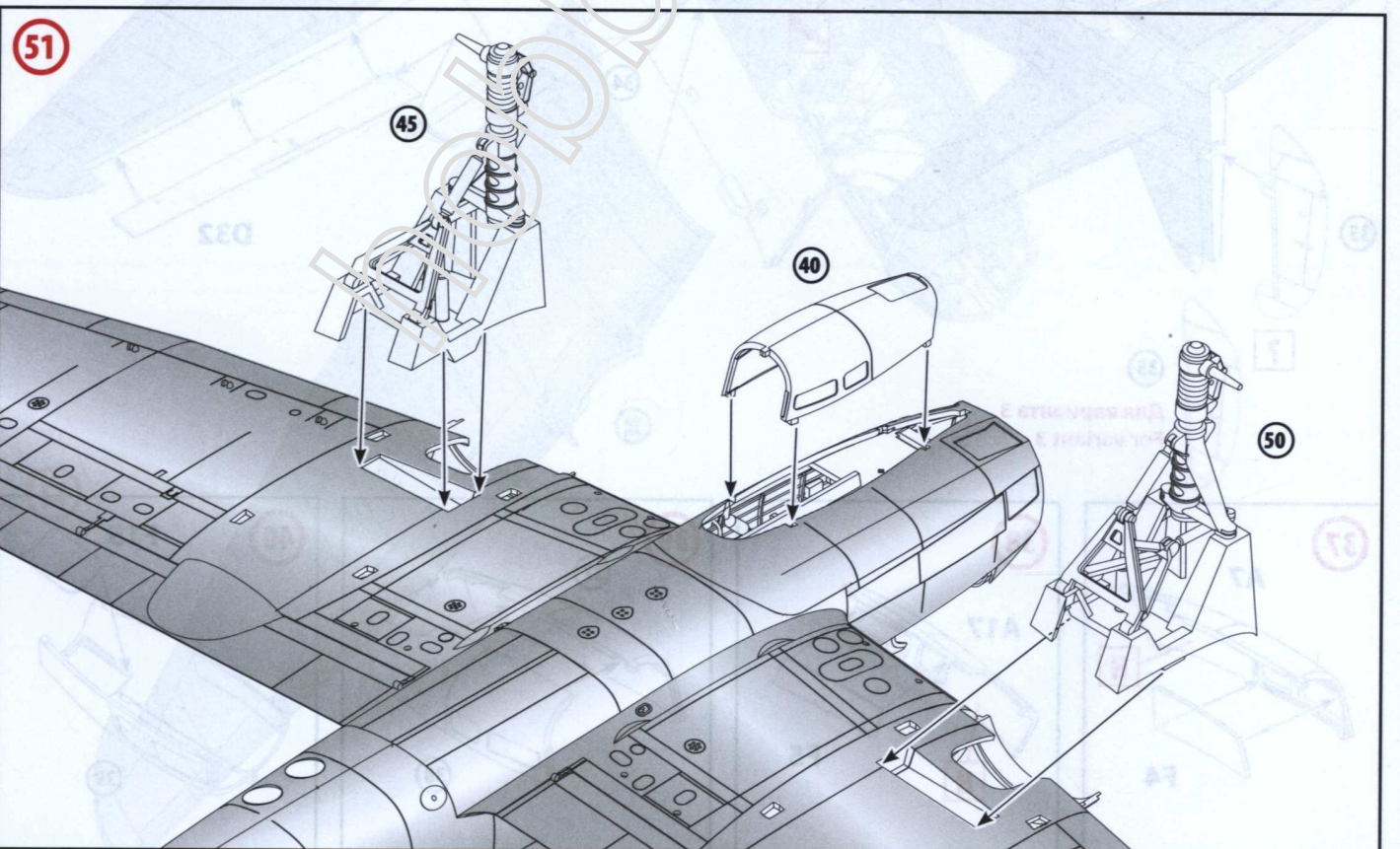
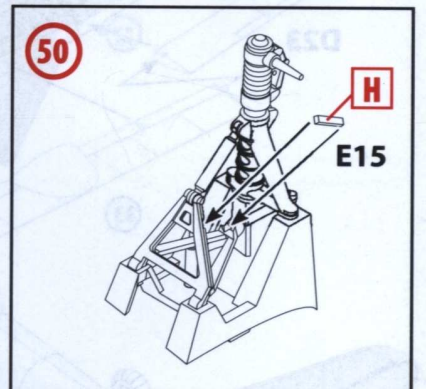
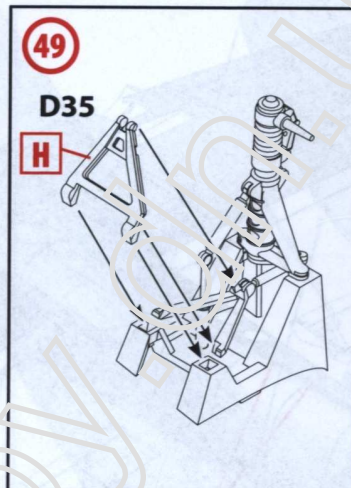
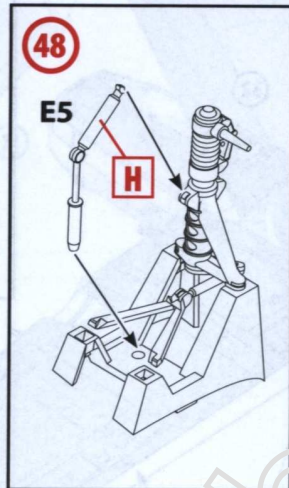
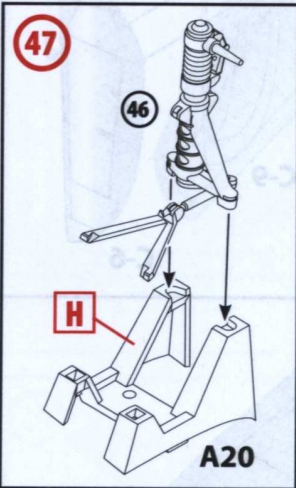
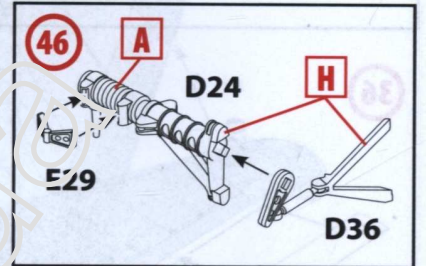
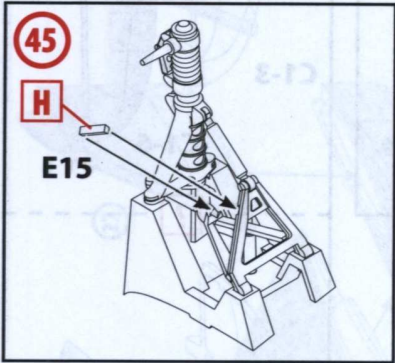
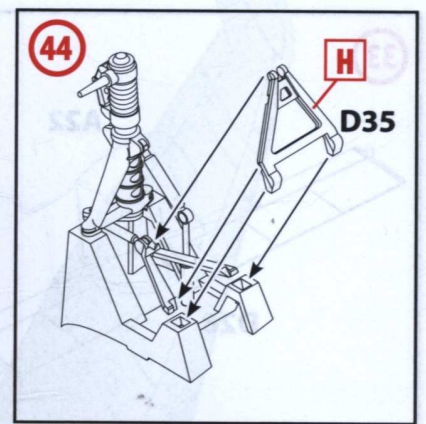
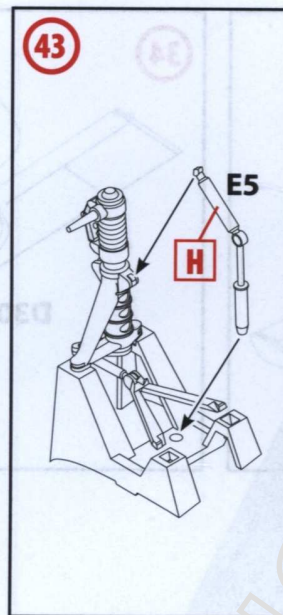
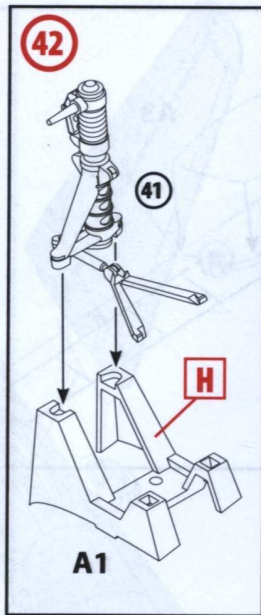
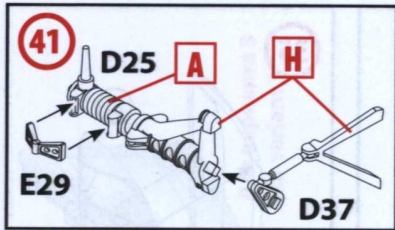

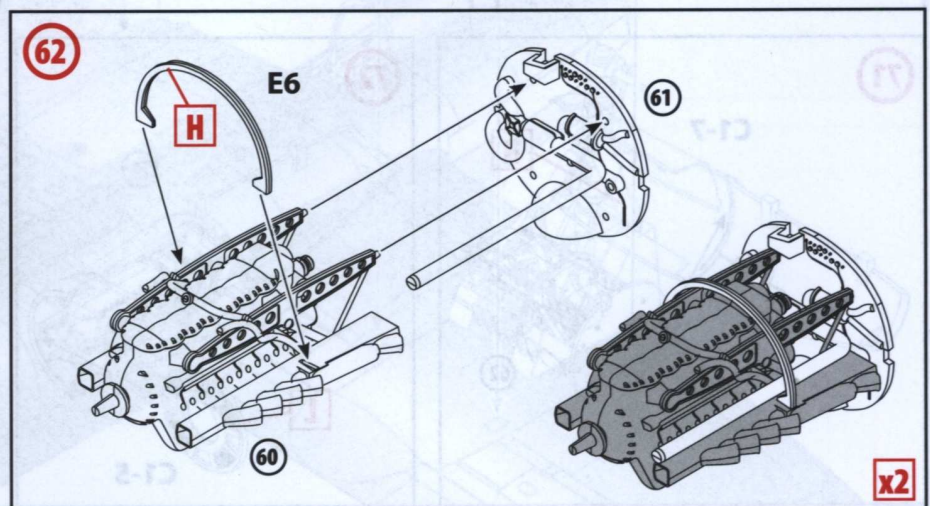
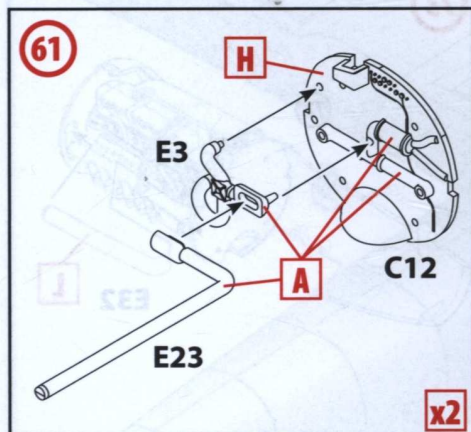
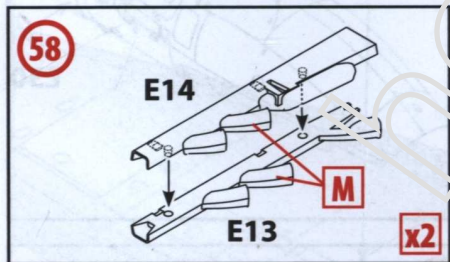
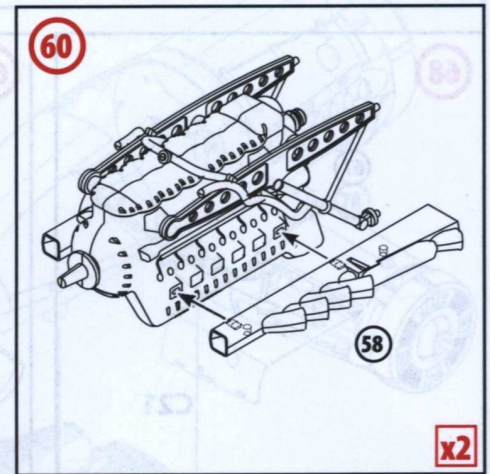
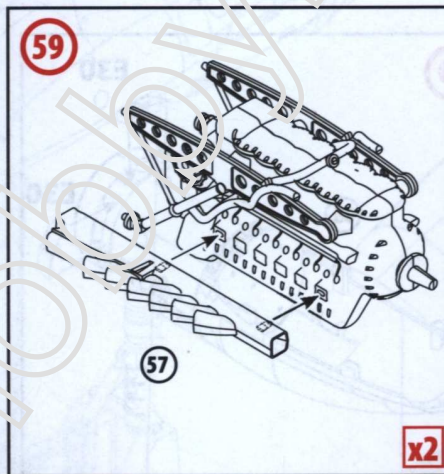
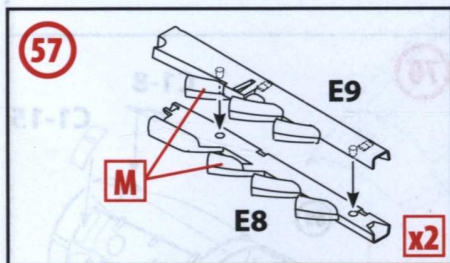
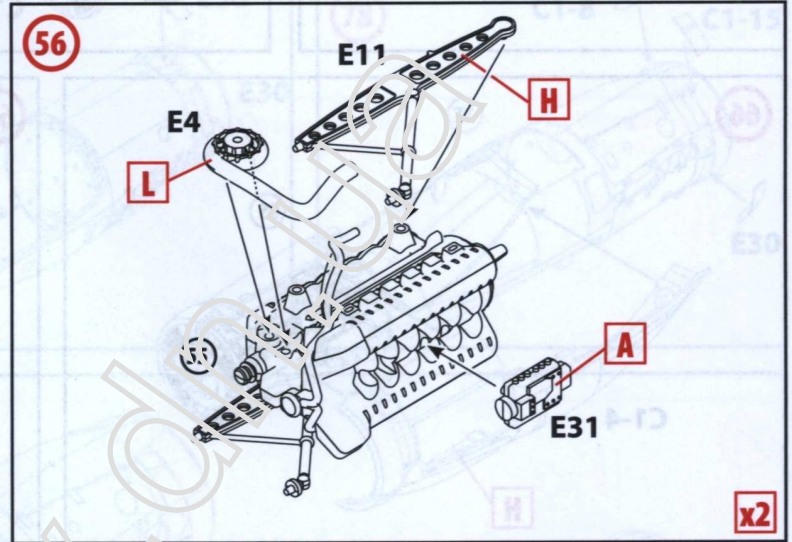
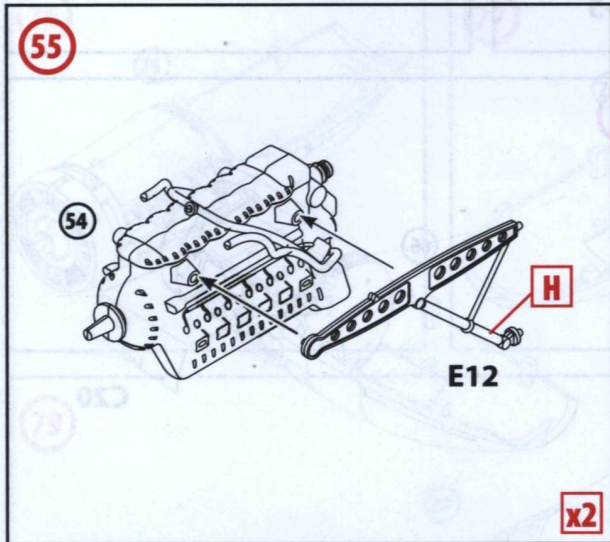
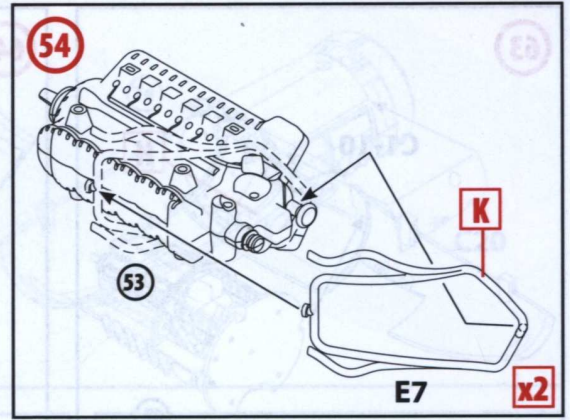
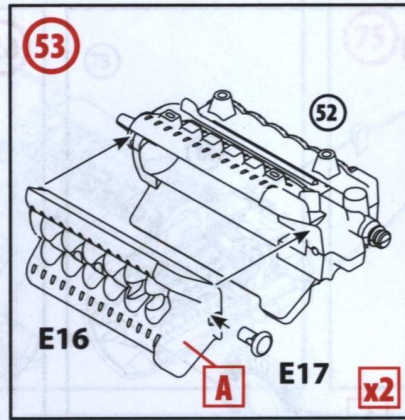
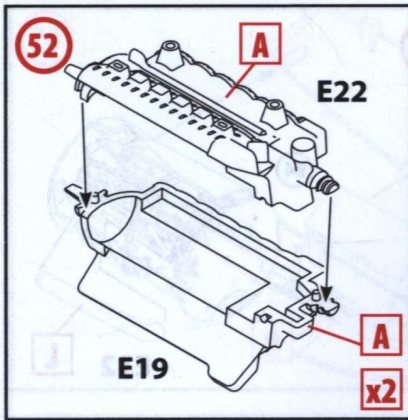

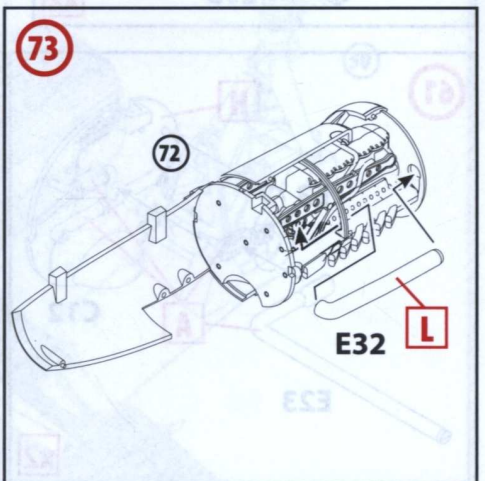
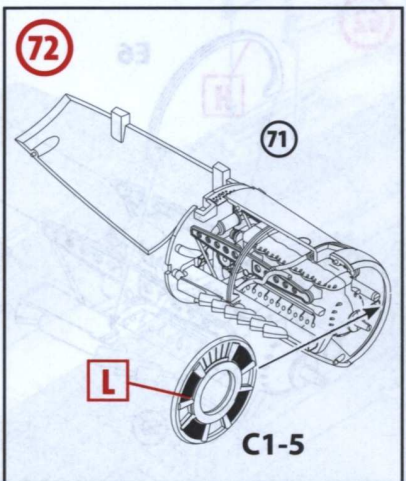
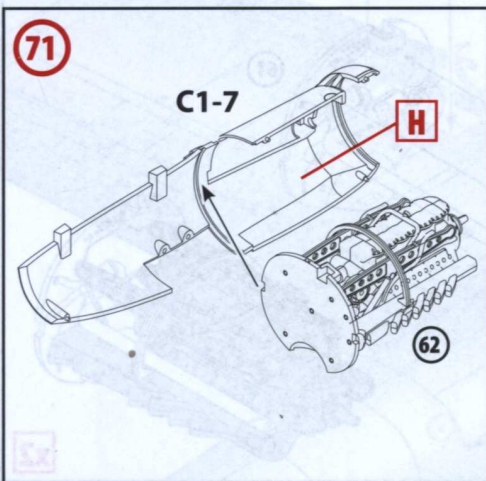
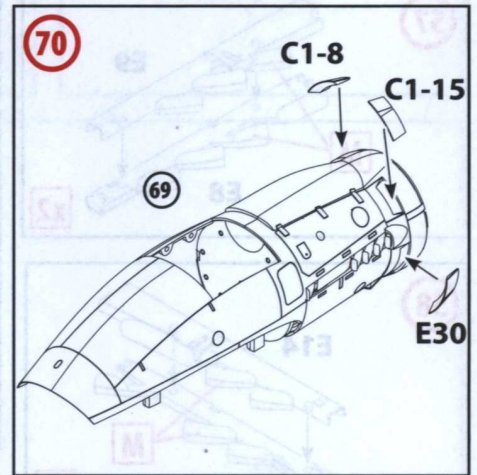
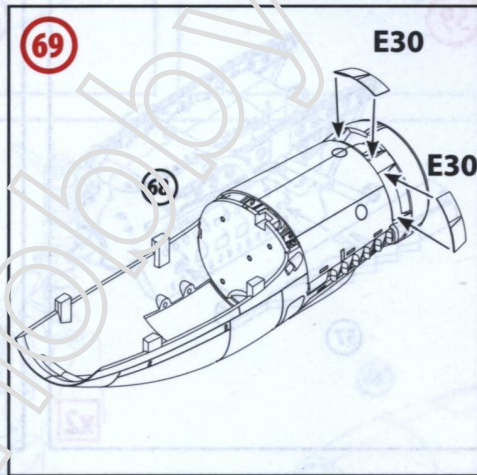
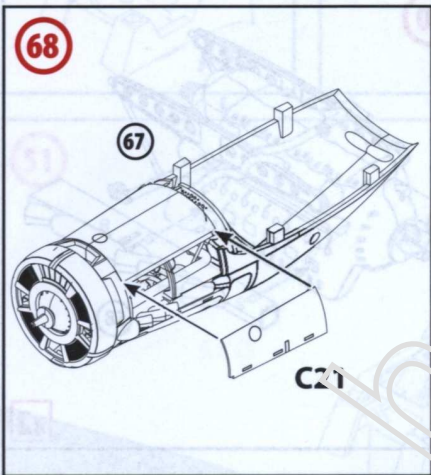
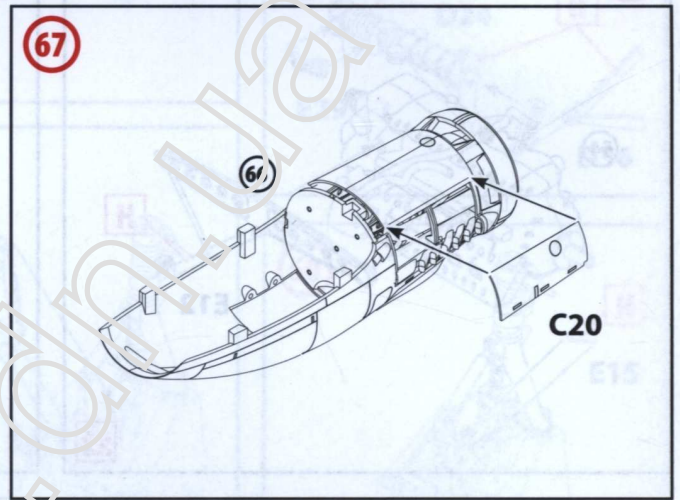
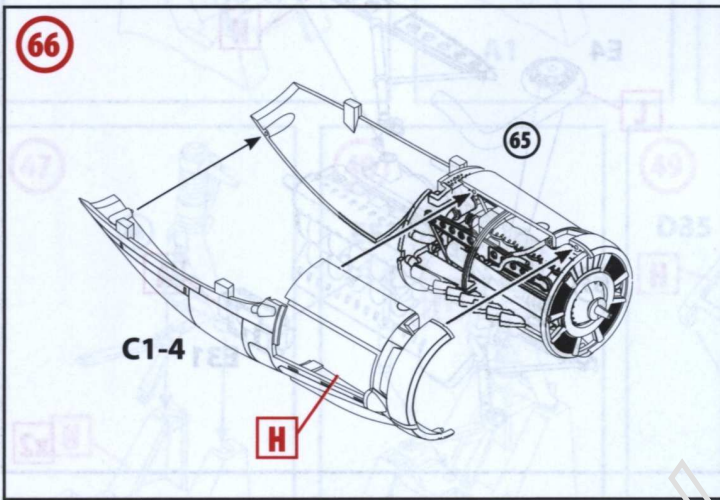
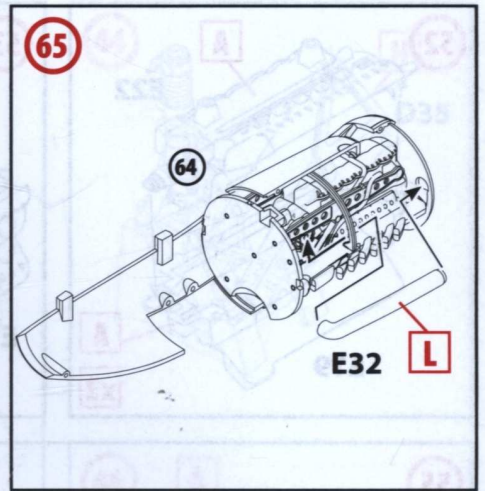
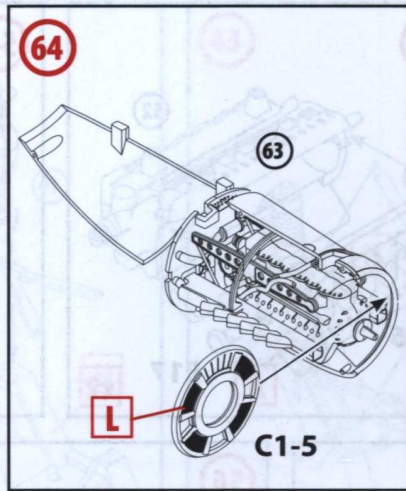
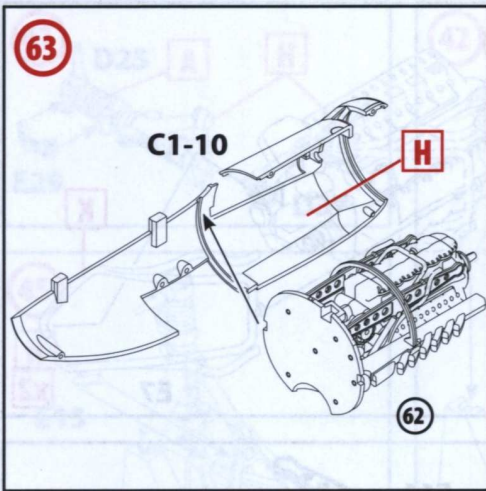

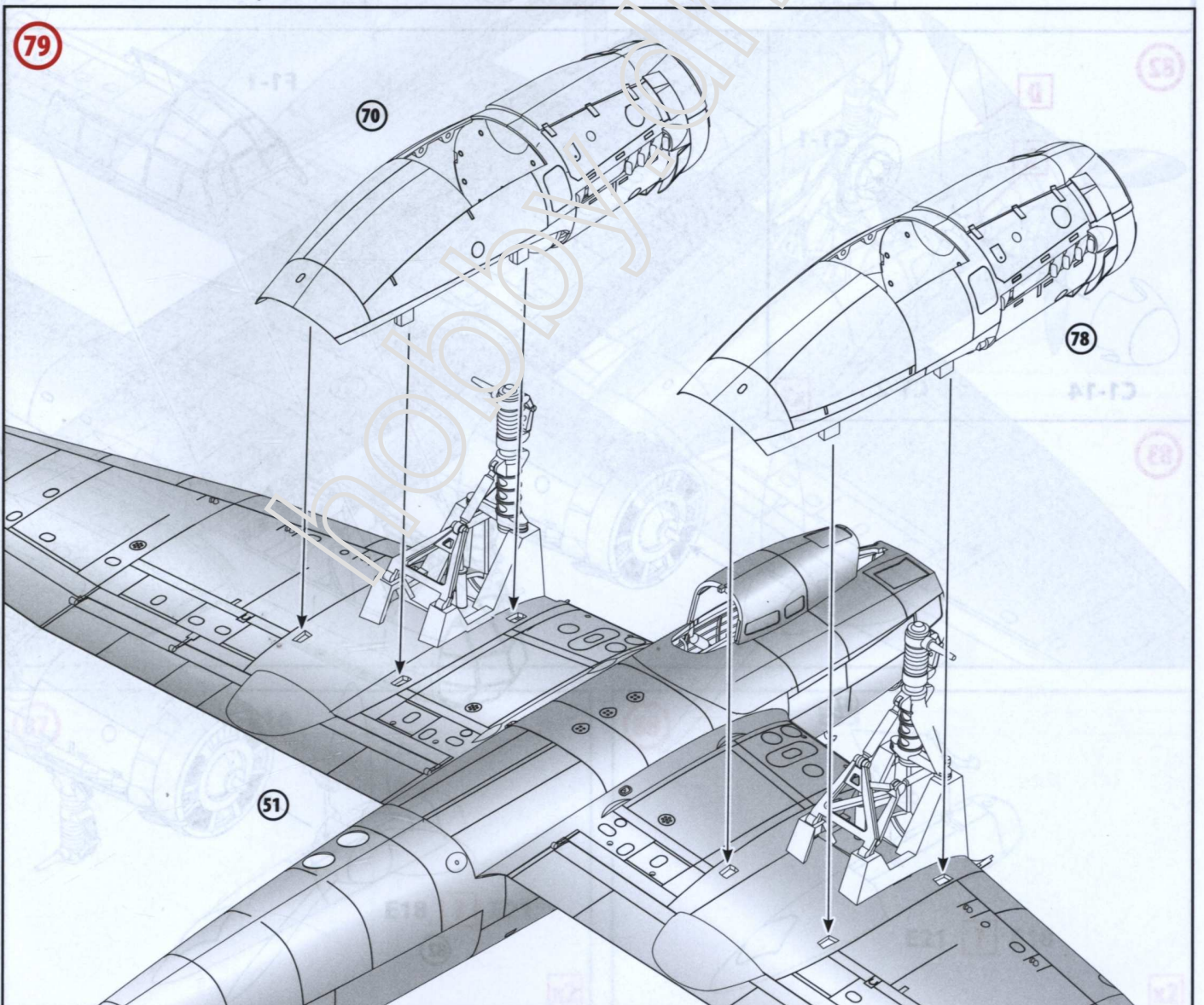
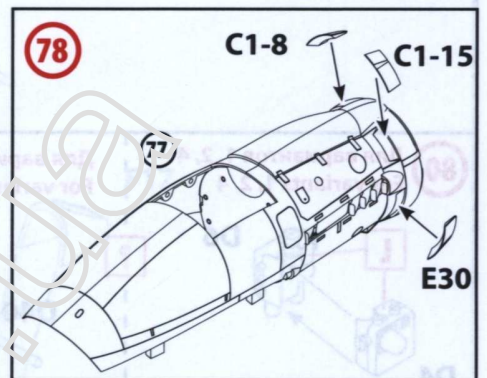
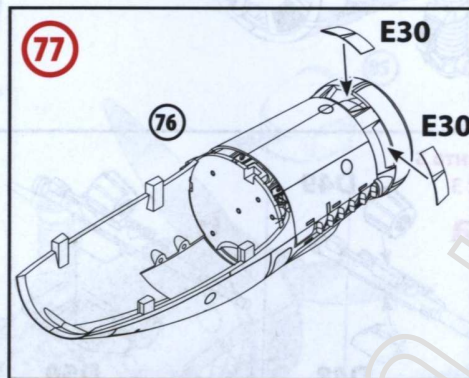
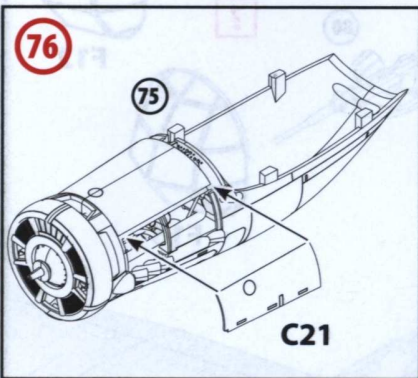
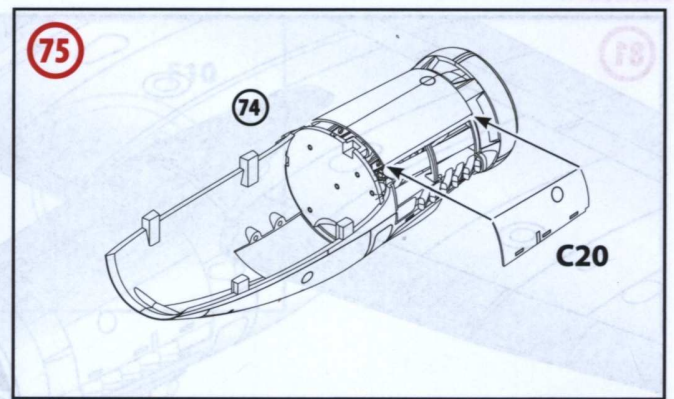
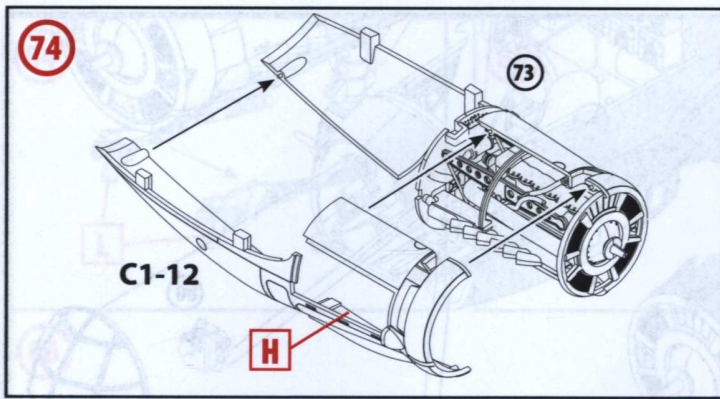

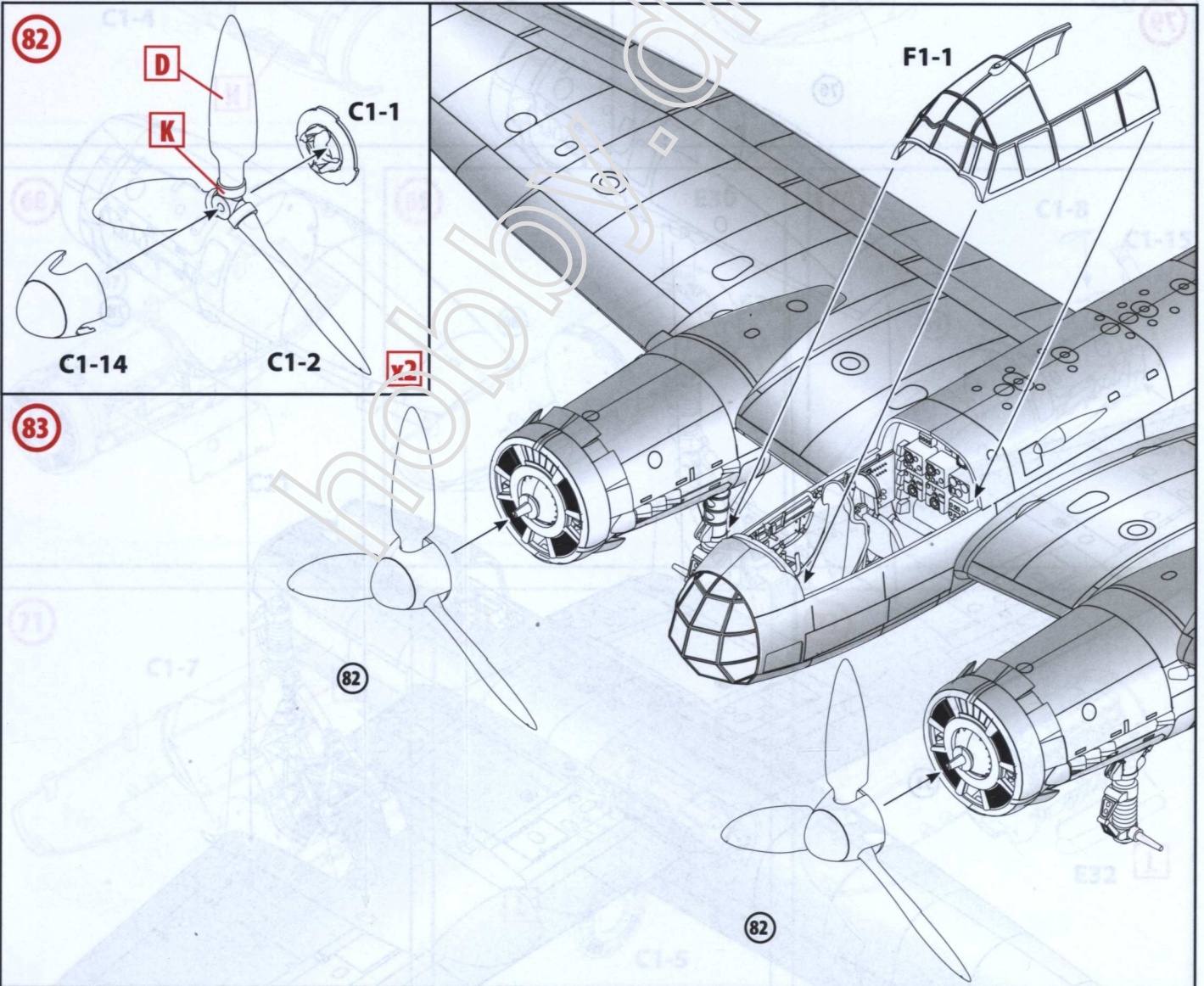
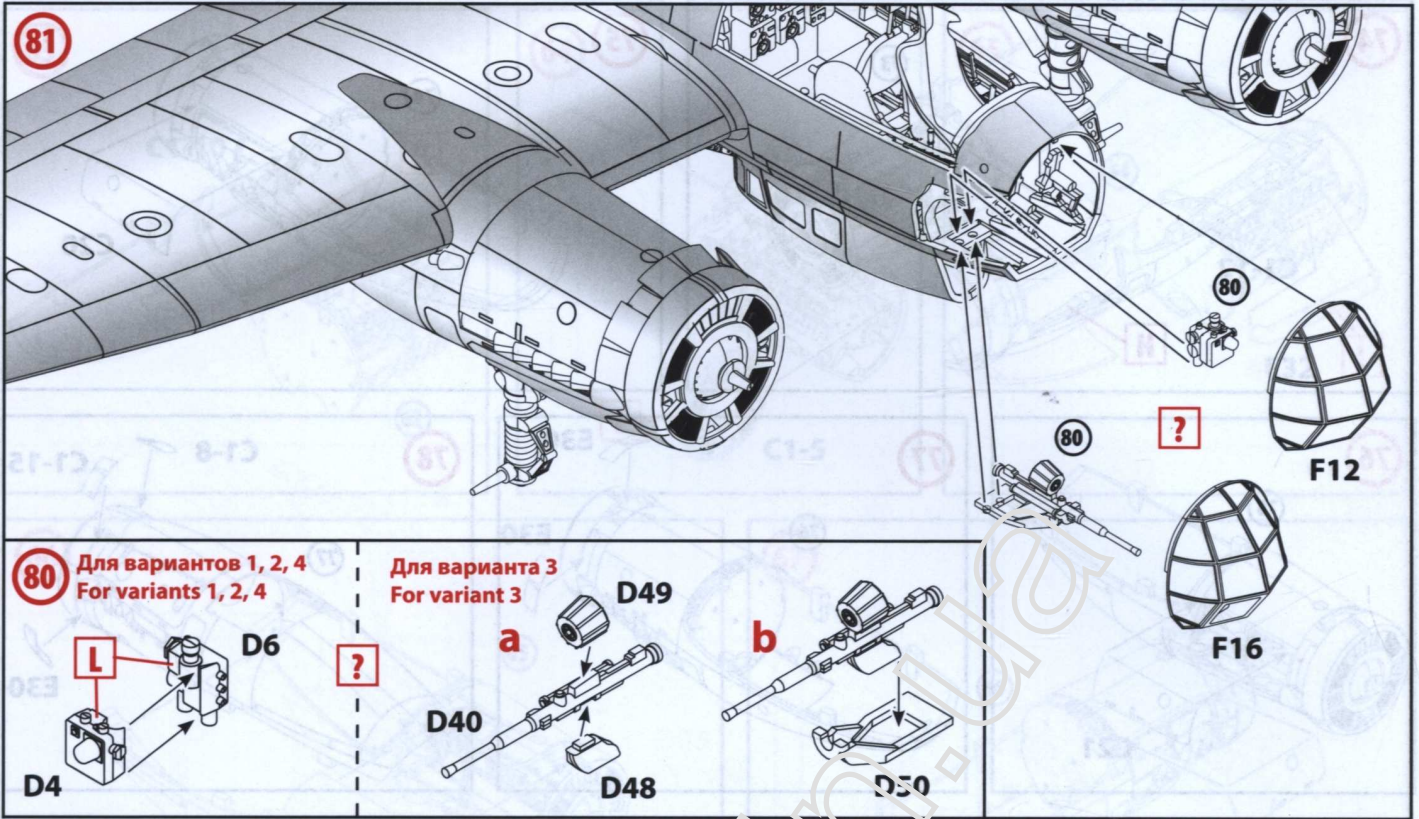

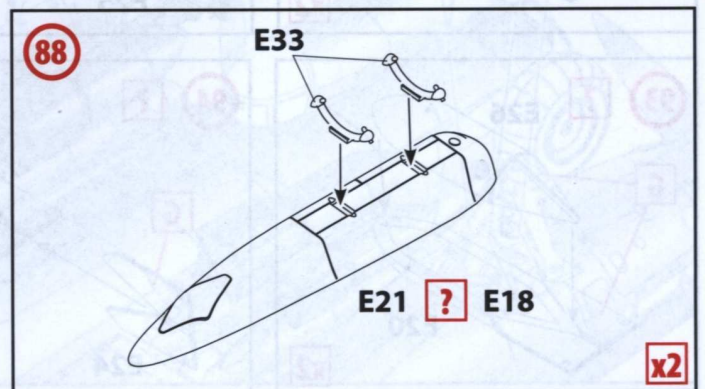
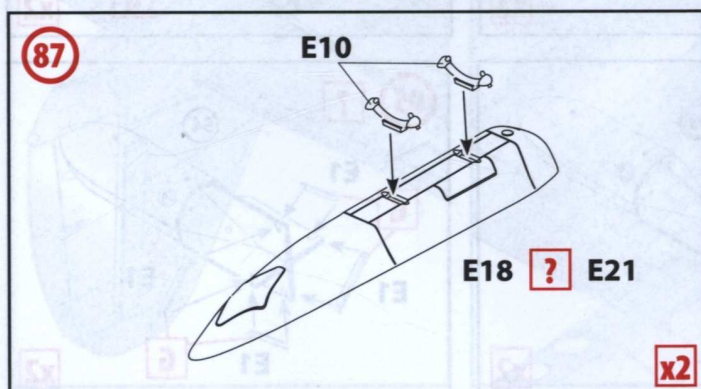
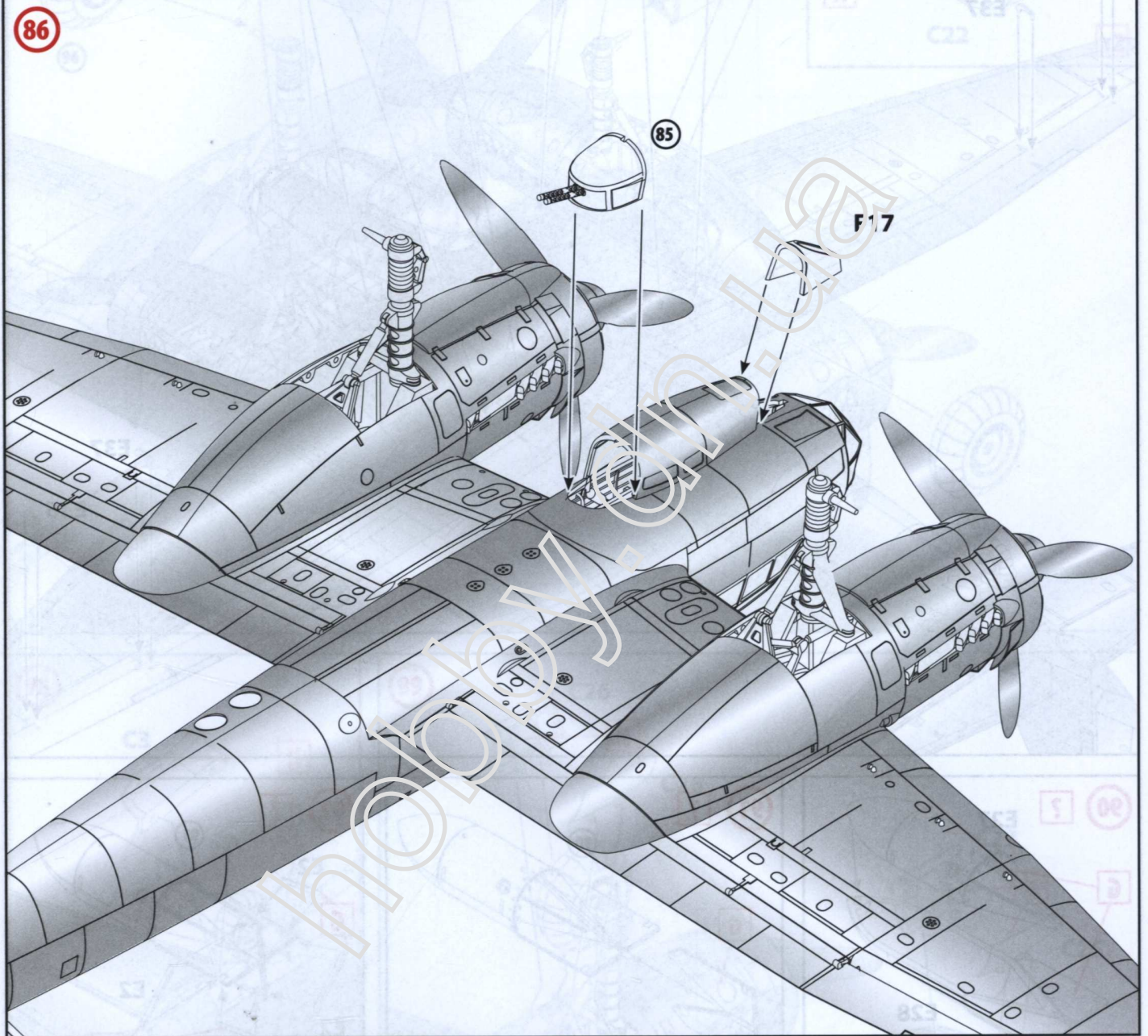
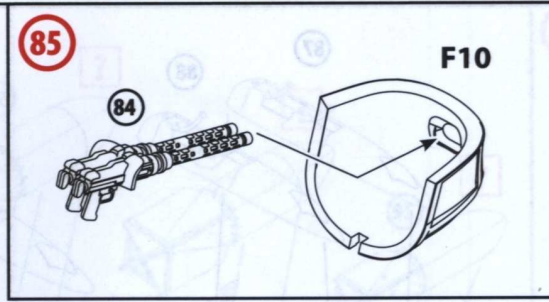
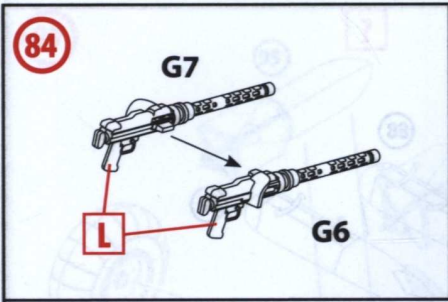

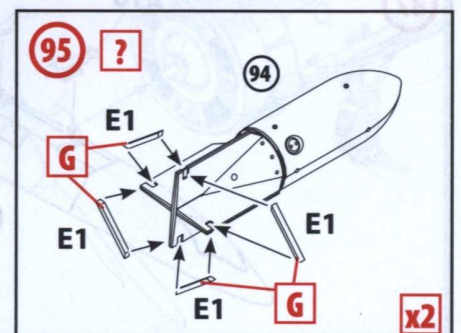
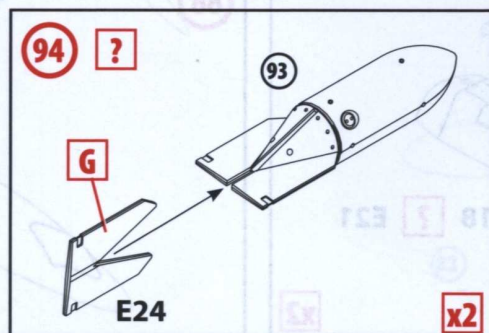
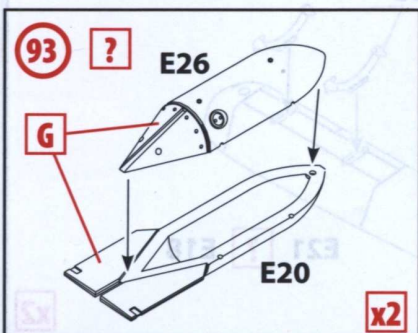
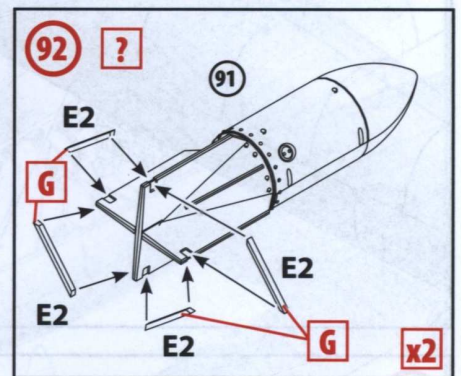
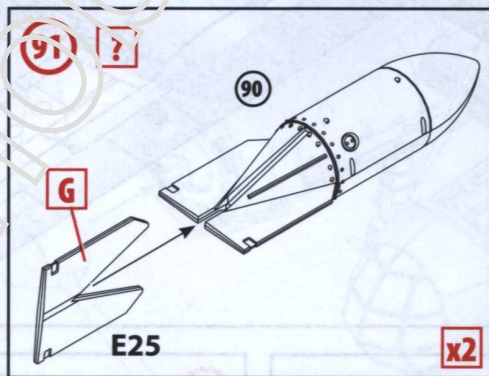
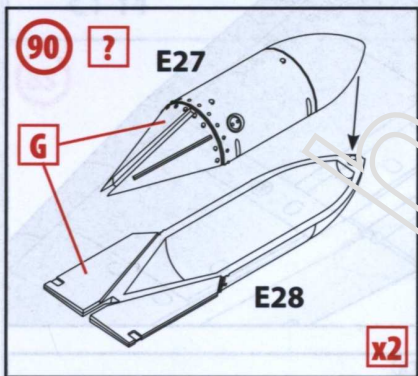
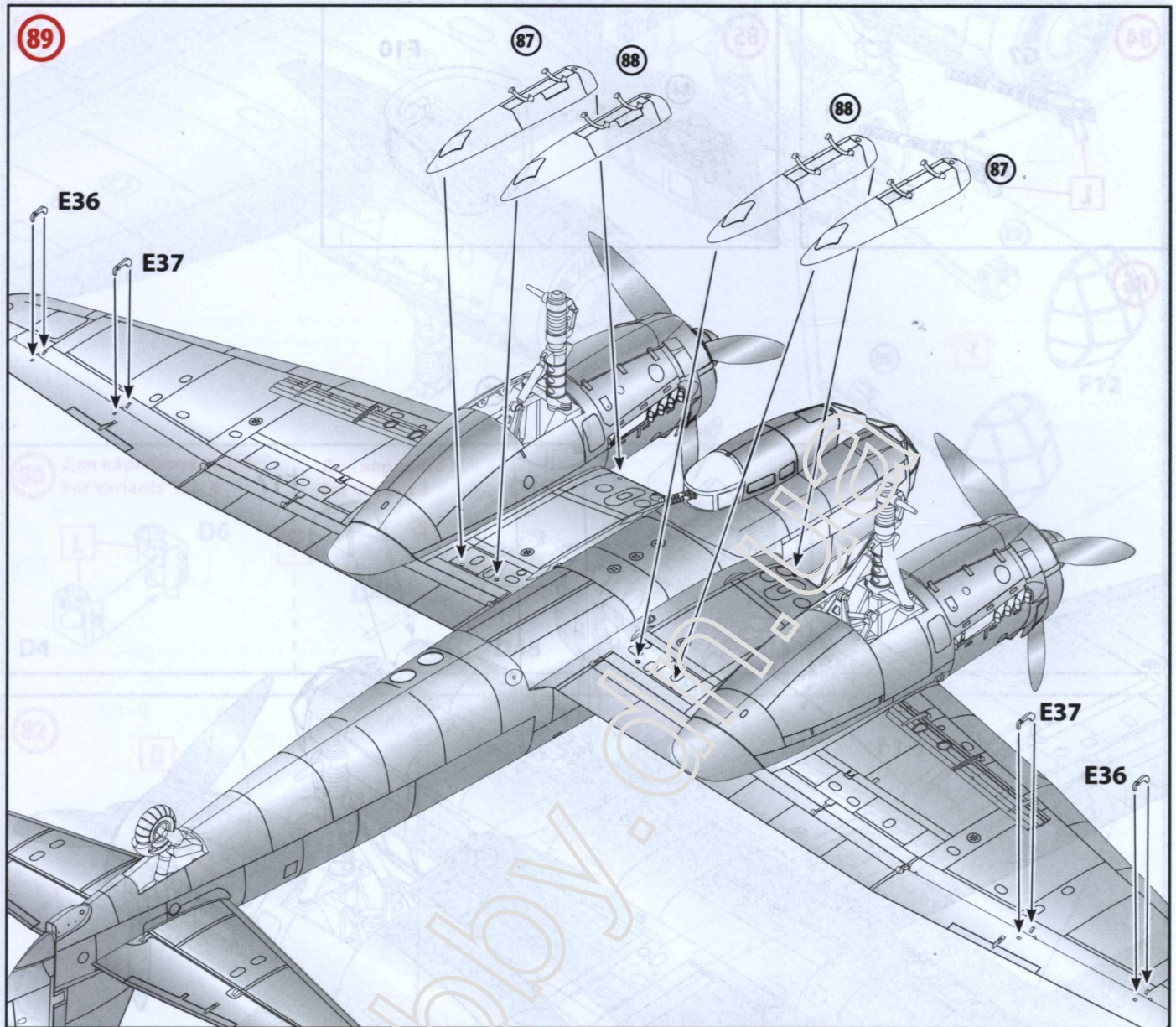

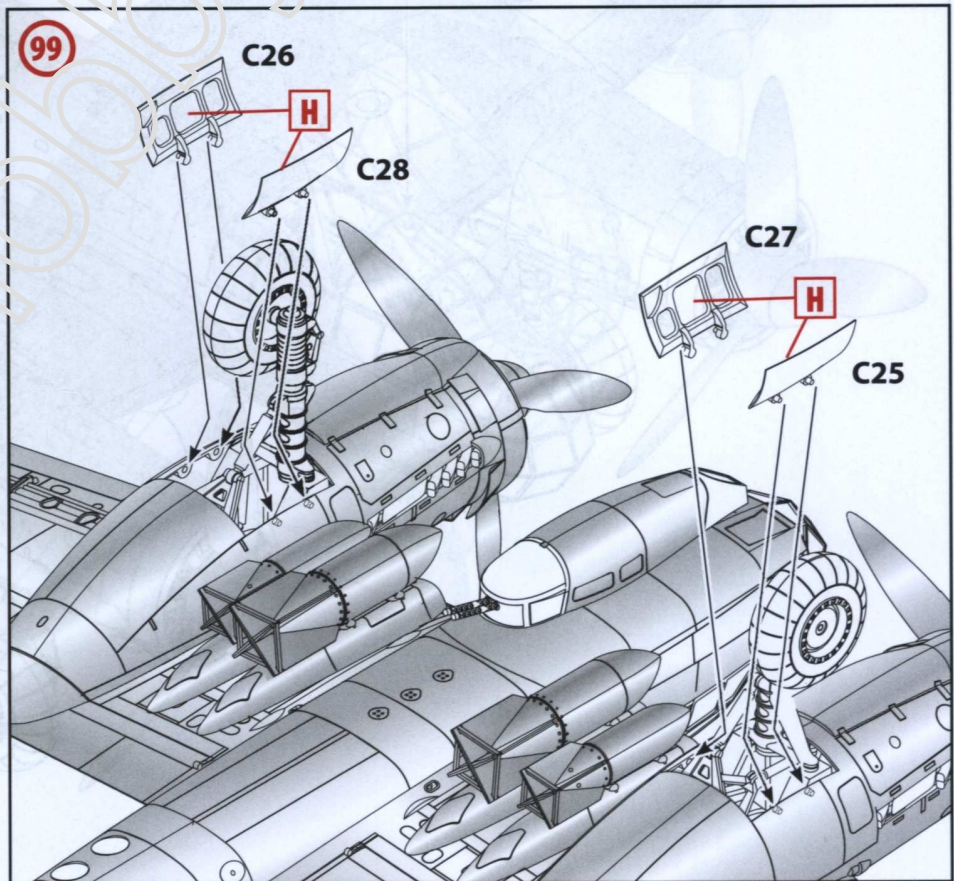
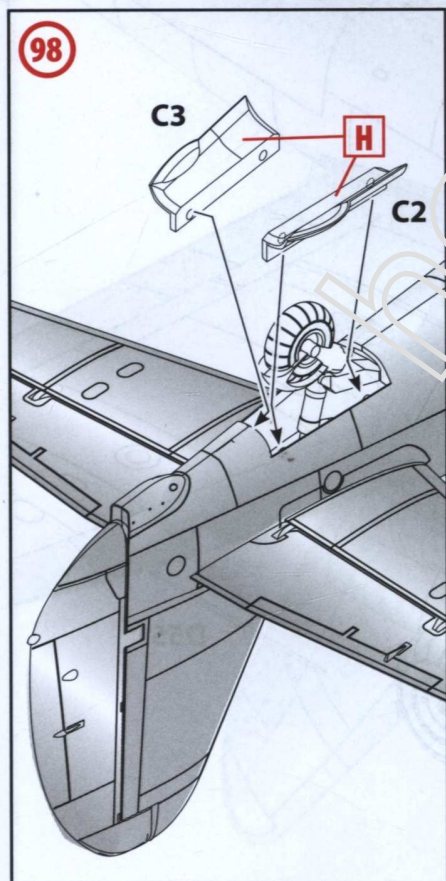
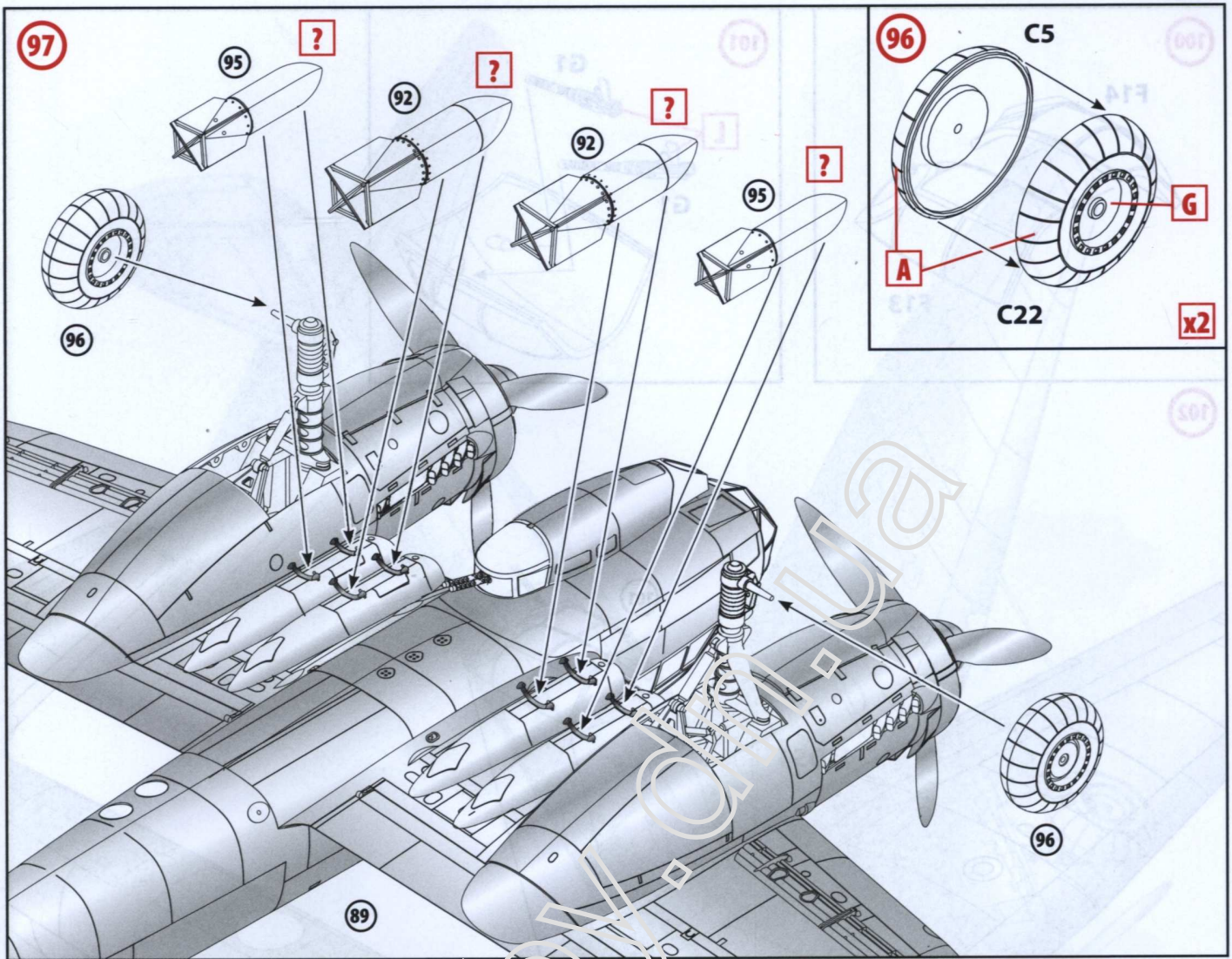

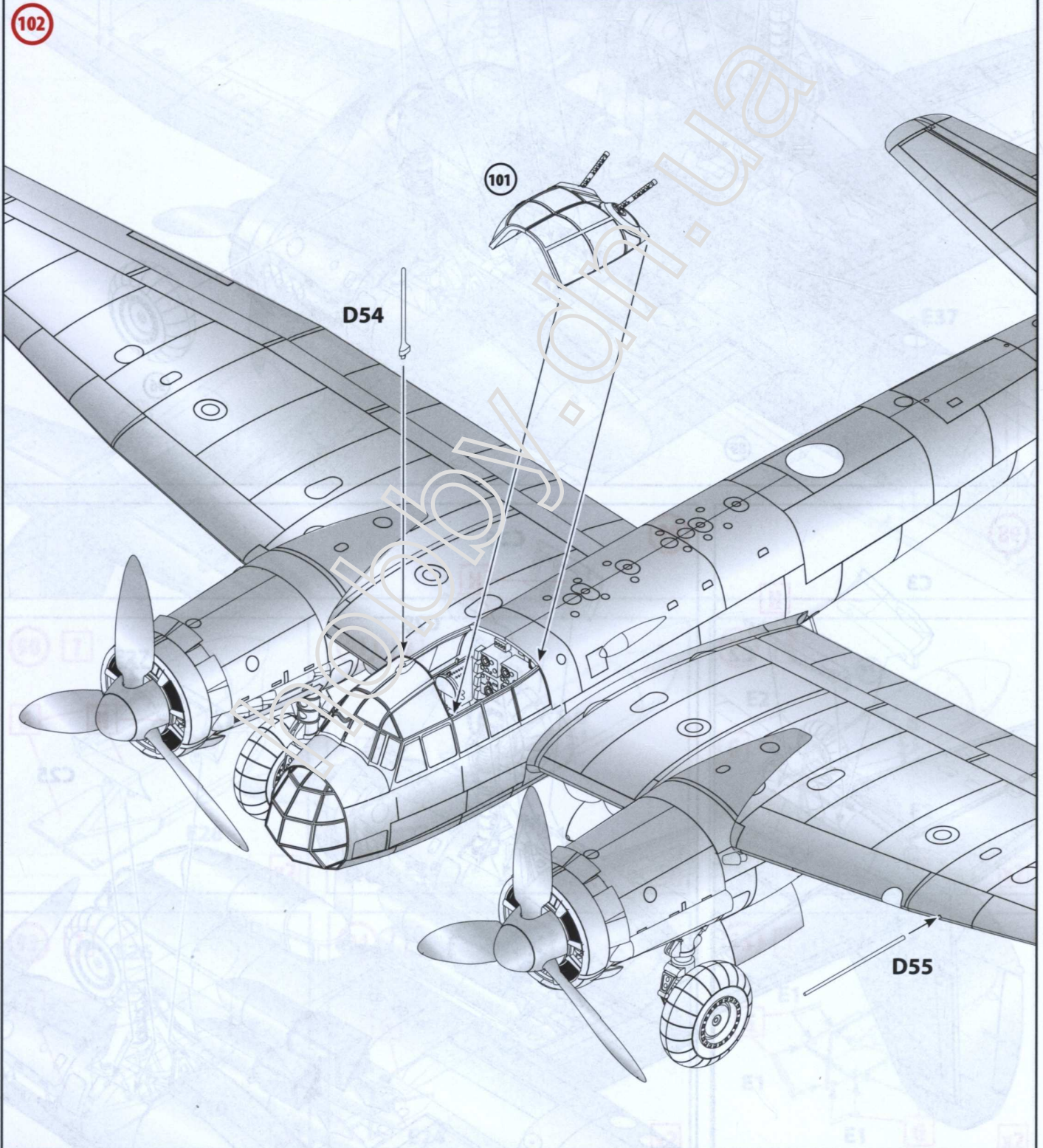
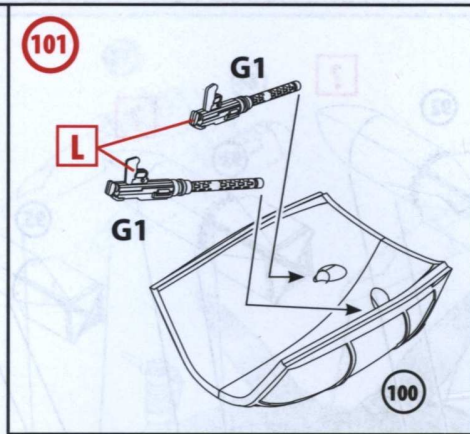
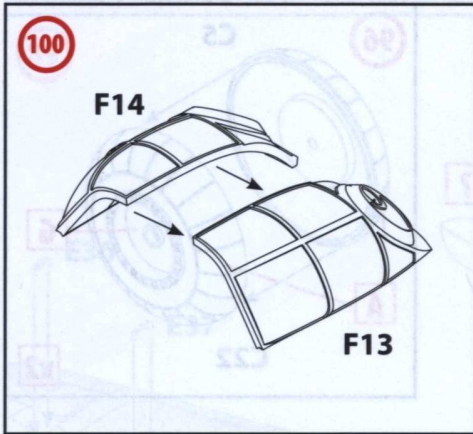

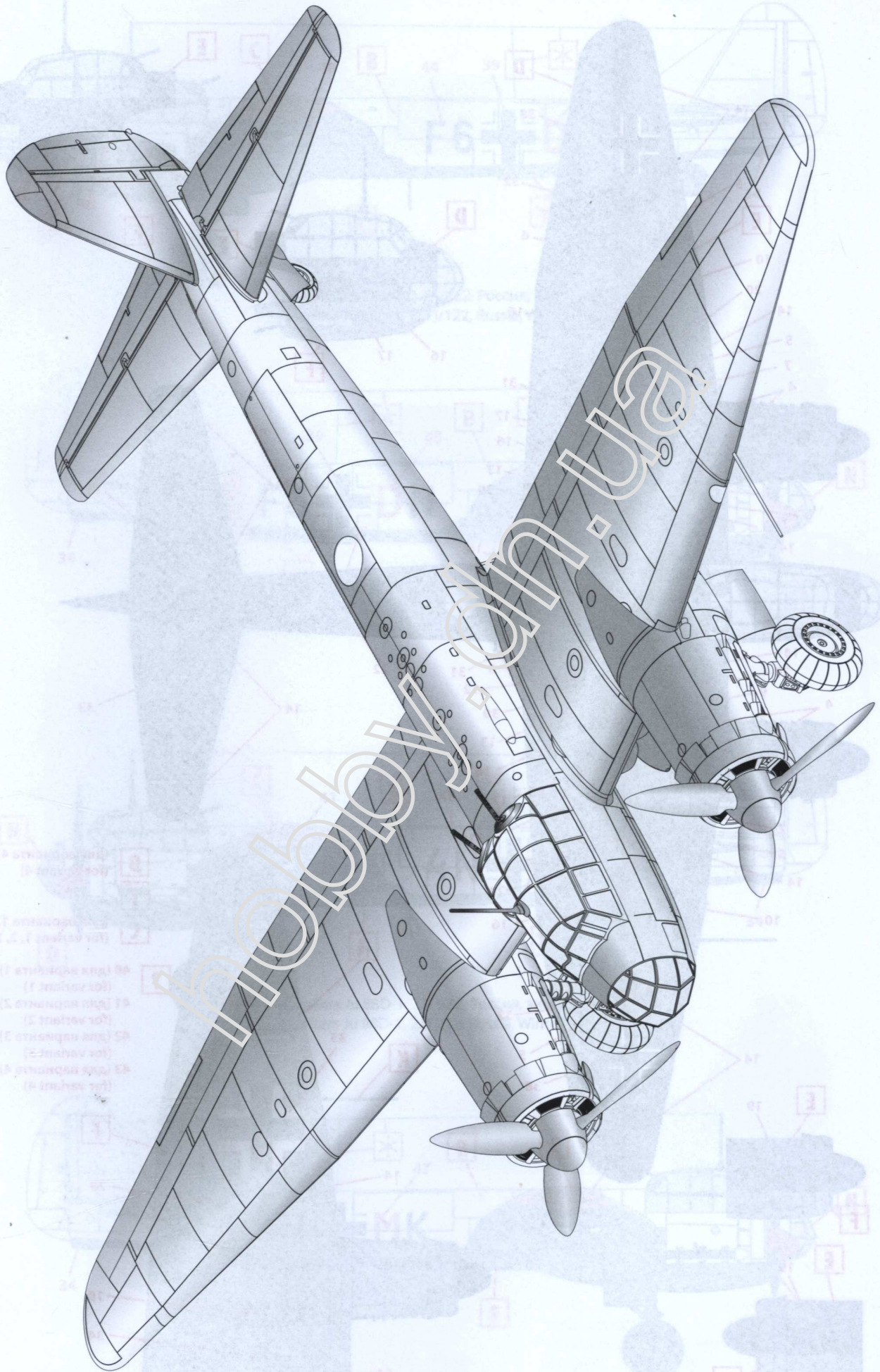

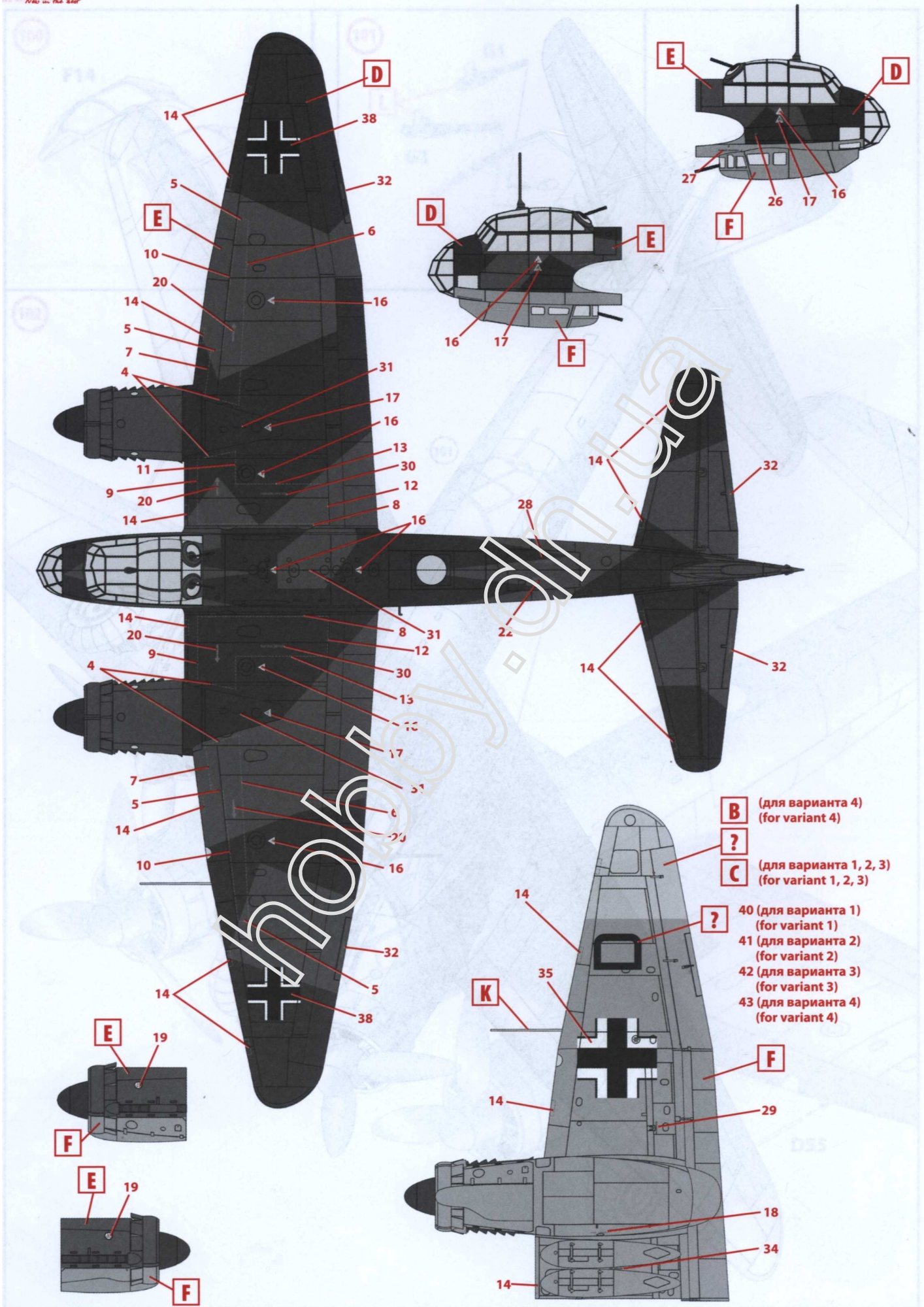

- B** (для варианта 4)
(for variant 4)
- ?**
- C** (для варианта 1, 2, 3)
(for variant 1, 2, 3)
- ?** 40 (для варианта 1)
(for variant 1)
- 41 (для варианта 2)
(for variant 2)
- 42 (для варианта 3)
(for variant 3)
- 43 (для варианта 4)
(for variant 4)

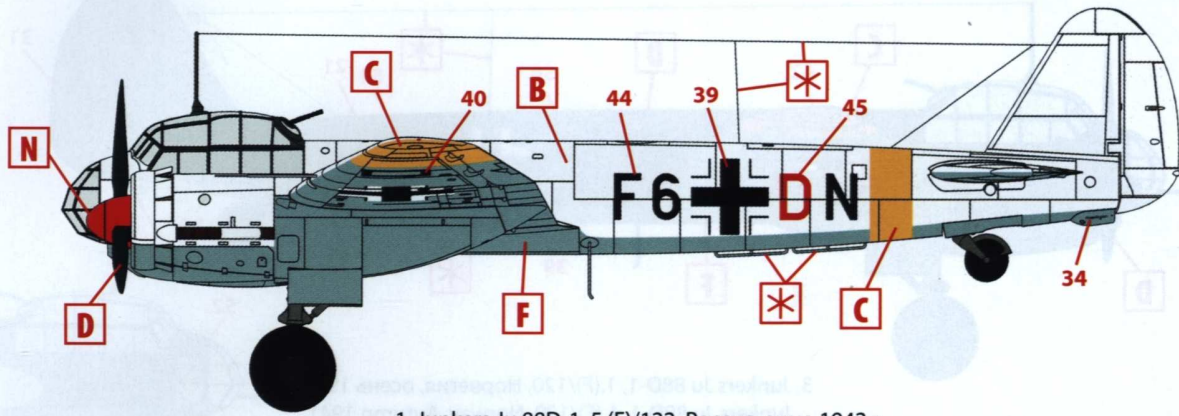

1. Junkers Ju 88D-1, 5.(F)/122, Россия, зима 1942 г.
 Junkers Ju 88D-1, 5.(F)/122, Russia, Winter 1942

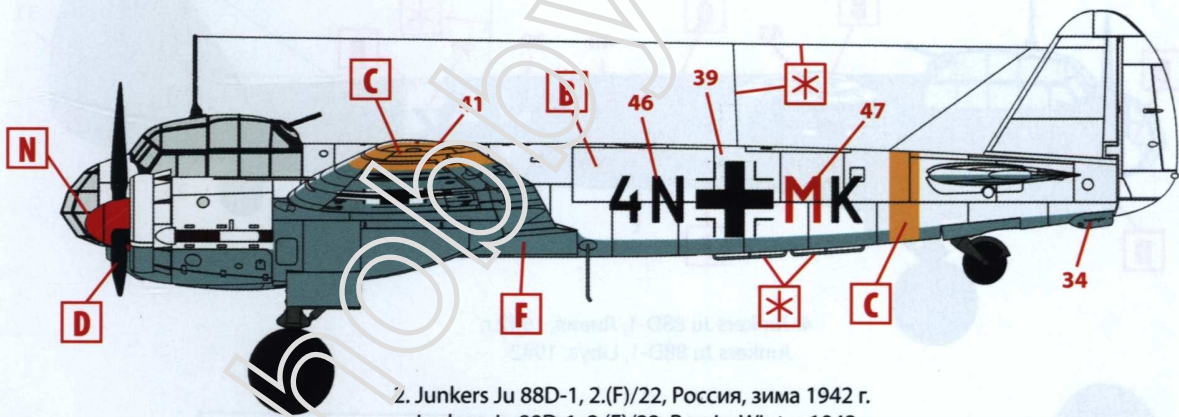
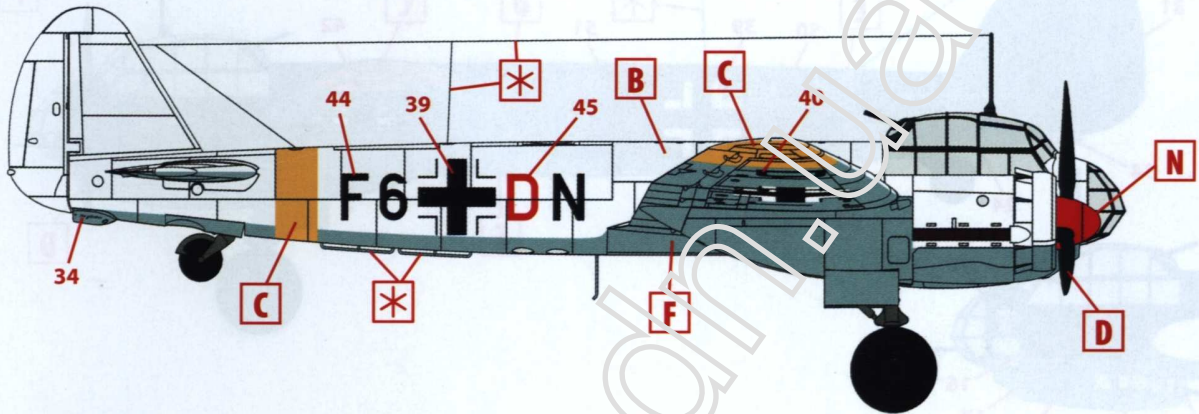

2. Junkers Ju 88D-1, 2.(F)/22, Россия, зима 1942 г.
 Junkers Ju 88D-1, 2.(F)/22, Russia, Winter 1942

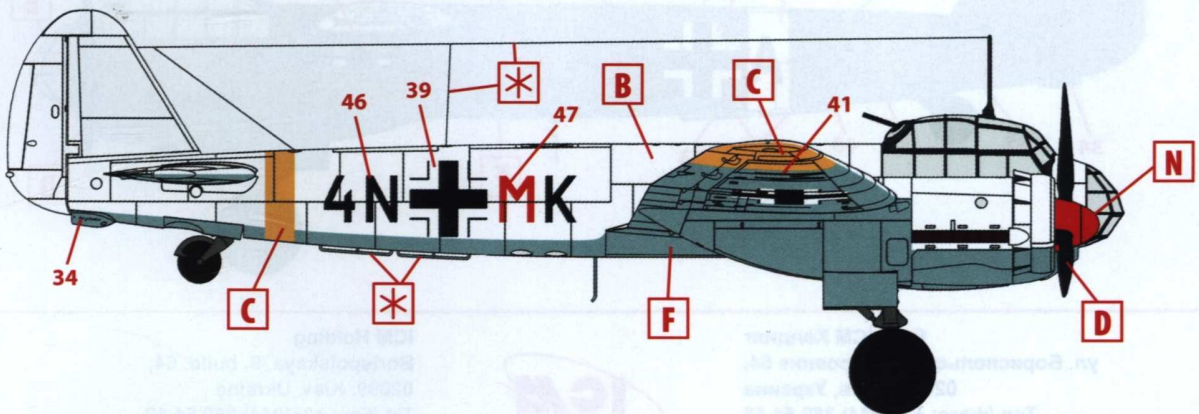

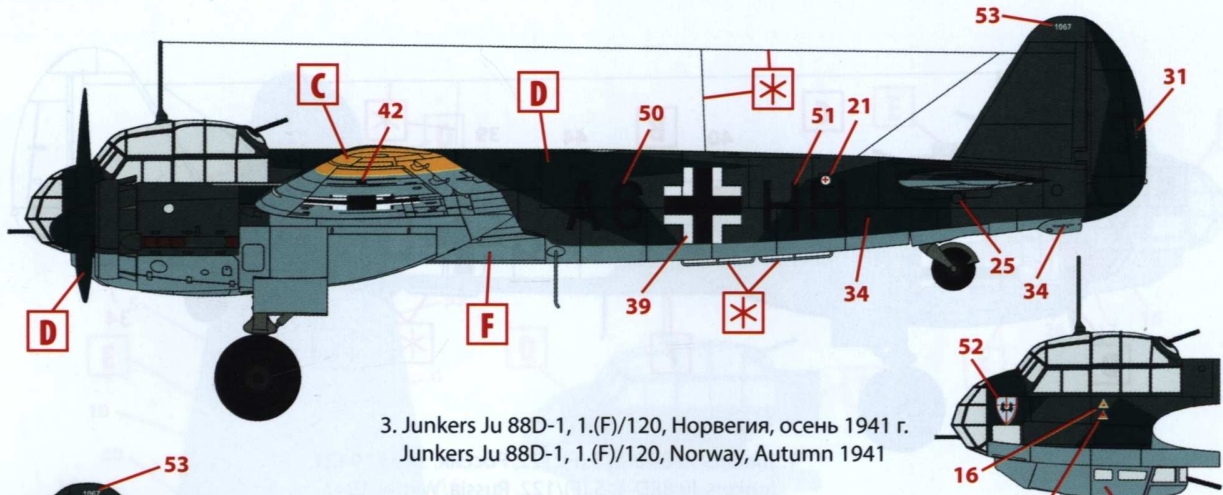

3. Junkers Ju 88D-1, 1.(F)/120, Норвегия, осень 1941 г.
Junkers Ju 88D-1, 1.(F)/120, Norway, Autumn 1941

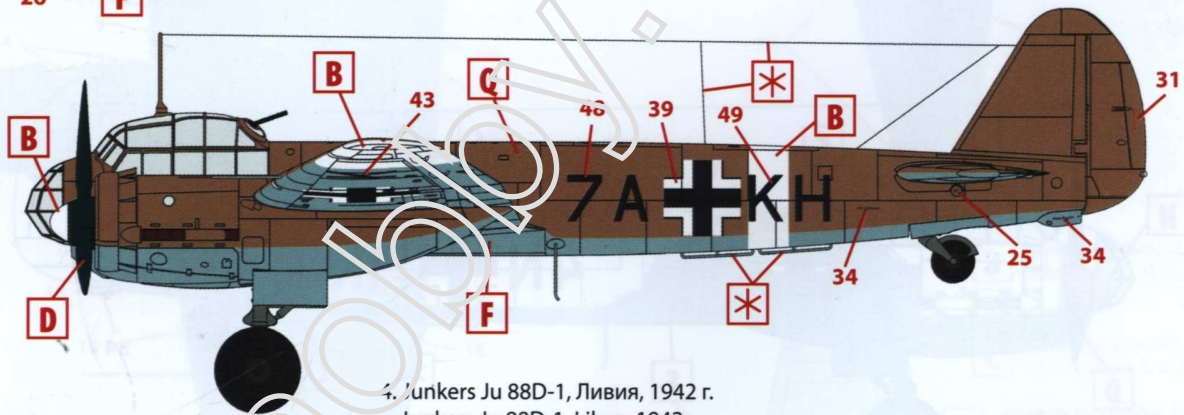
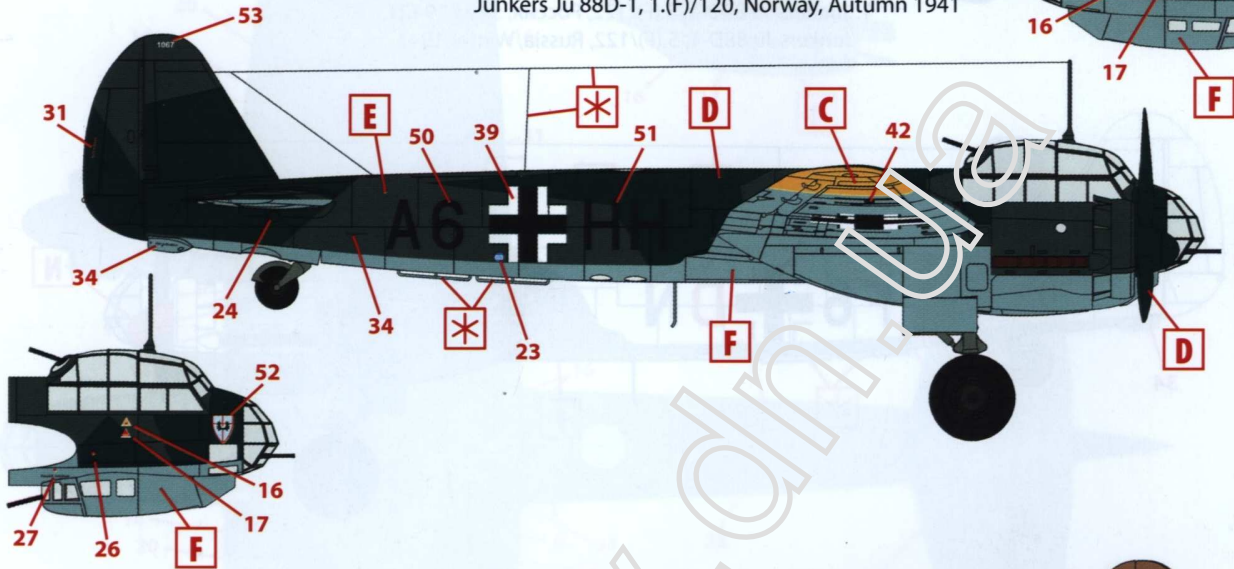

4. Junkers Ju 88D-1, Ливия, 1942 г.
Junkers Ju 88D-1, Libya, 1942

