



Do 17Z-2

Бомбардировщик ВВС Финляндии II MB

В начале 30-х годов в мире возникла идея создания скоростного бомбардировщика, который мог бы обогнать современные ему истребители-бипланы. Одним из воплощений этой концепции стал двухмоторный бомбардировщик Do 17, разработанный германской фирмой Дорнье Флюгцугверке.

С начала 1939 г. началось производство самолетов Do 17Z с новой носовой частью типа "Waffenkopf", на которых были установлены двигатели воздушного охлаждения Bramo 323 Fafnir.

В 1939-1940 г. были выпущены около 500 бомбардировщиков Do 17Z-1 and Do 17Z-2. Они принимали участие во всех операциях Люфтваффе 1939-1941 г.г. Также эти самолеты находились на вооружении ВВС Финляндии.

Тактико-технические характеристики Do 17Z-2

| | |
|-----------------------------|--|
| Длина, м | 15,8 |
| Размах крыла, м | 18,0 |
| Взлетный вес, кг | 8700 |
| Двигатели | 2xBramo 323P, 1000 л.с. |
| Максимальная скорость, км/ч | 426 |
| Потолок, м | 8200 |
| Дальность, км | 1160 |
| Вооружение | 4-6x7,92-мм пулеметов MG 15, до 1000 кг бомб |

ВНИМАНИЕ!

Перед сборкой внимательно прочитать руководство по монтажу. Каждая деталь пронумерована. Соблюдать последовательность монтажа. Необходимые рабочие инструменты: нож и напильник для зачистки деталей; резиновая лента, клейкая лента и зажимы для сушки белья для прижимания склеиваемых деталей. Детали из пластика очистить в растворе мягкого моющего средства и высушить на воздухе для того, чтобы краска и переводные картинки лучше прилипали. Перед приклеиванием проверить, подходят ли детали; клей наносить экономно. Хром и краску удалить с поверхностей склеивания. Небольшие детали покрасить перед тем, как они будут удалены из рамок. Краску необходимо хорошо просушить, только после этого продолжать сборку. Каждую соответствующую переводную картинку отдельно вырезать и примерно на 20 секунд окунуть в теплую воду. На обозначенном месте картинку отделить от бумаги и прижать промокающей бумагой.

Do 17Z-2

WWII Finnish Bomber

In the beginning of 30s it was appeared in the world an idea of high-speed bomber that could outstrip contemporary fighters. One of the objectifications of this conception became the twin-engine bomber Do 17 designed by a German Dornier Flugzeugwerke company.

Since the beginning of 1939 it were produced Do 17Z planes with new "Waffenkopf" type nose part and air-cooled Bramo 323 Fafnir engines.

In 1939-1940 it were produced about 500 Do 17Z-1 and Do 17Z-2 bombers. They took part in all 1939-1941 Luftwaffe operations. These aircraft were also transferred to Finland.

Tactical and Technical Specifications of Do 17Z-2

| | |
|--------------------|--|
| Length, m | 15,8 |
| Span, m | 18,0 |
| Start weight, kg | 8700 |
| Engines | 2xBramo 323P, 1000 hp |
| Max. Speed, km/h | 426 |
| Service ceiling, m | 8200 |
| Range, km | 1160 |
| Armament | 4-6x7,92 mm MG 15, bomb load - up to 1000 kg |

CAUTION!

Read the instructions thoroughly prior to assembly. Each component is numbered. Adhere to specified sequence of assembly. Tools required: knife and file for removal of components from frame; rubber bond, adhesive tape and clothes pegs for clamping components together after applying adhesive. Clean plastic components in a mild detergent solution and allow to air-dry so that paint and transfers adhere better. Prior to applying adhesive, check to see whether the components fit together; apply adhesive sparingly. Remove chrome and paint from the contact surfaces. Paint small components before removing them from the frame. Allow paint to dry well, and only then continue to assemble. Cut out each transfer individually and immerse in warm water for approx. 20 seconds. Slide transfer off paper and into designated position, then press on with blotting paper.

ИСПОЛЗУЕМЫЕ КРАСКИ / USED COLORS:

| | Revell | Tamiya | | |
|----------|--------|--------|----------------------|-------------------|
| A | 108 | XF1 | Черный, матовый | Flat Black |
| B | 105 | XF2 | Белый, матовый | Flat White |
| C | 115 | XF3 | Желтый, матовый | Flat Yellow |
| D | 140 | XF27 | Черно-зеленый RLM 70 | Schwarzgrun RLM70 |
| E | 361 | XF58 | Оливково-зеленый | Olive Green |
| F | 149 | XF23 | Голубой RLM65 | Hellblau RLM65 |
| G | 177 | XF84 | Черно-серый, матовый | Schwarzgrau RLM66 |

| | Revell | Tamiya | | |
|----------|--------|--------|-----------------------|------------|
| H | 145 | XF22 | Серо-зеленый RLM02 | Grau RLM02 |
| J | 199 | XF16 | Алюминий, полуматовый | Aluminium |
| K | 191 | X11 | Сталь | Steel |
| L | 109 | X10 | Темный металл | Gun Metal |
| M | 183 | XF64 | Ржавчина | Rust |
| N | 330 | XF7 | Красный, матовый | Flat Red |
| P | 364 | XF26 | Зеленый, матовый | Flat Green |

01 СТАДИЯ СБОРКИ
ASSEMBLY STEP

03 СБОРОЧНАЯ ЕДИНИЦА
ASSEMBLY UNIT

A ИСПОЛЗУЕМАЯ КРАСКА
USED COLOR

x2 СДЕЛАТЬ ДВЕ ДЕТАЛИ
MAKE 2 PCS

■ ПРИ СБОРКЕ НЕ ИСПОЛЗУЕТСЯ
PARTS NOT FOR USE

⚡ ПРОСВЕРЛИТЬ
OPEN HOLE

***** СДЕЛАТЬ САМОМУ
SCRATCH BUILD

? ПРОИЗВОЛЬНЫЙ ВЫБОР
OPTIONAL

✂ ОТРЕЗАТЬ
CUT OFF

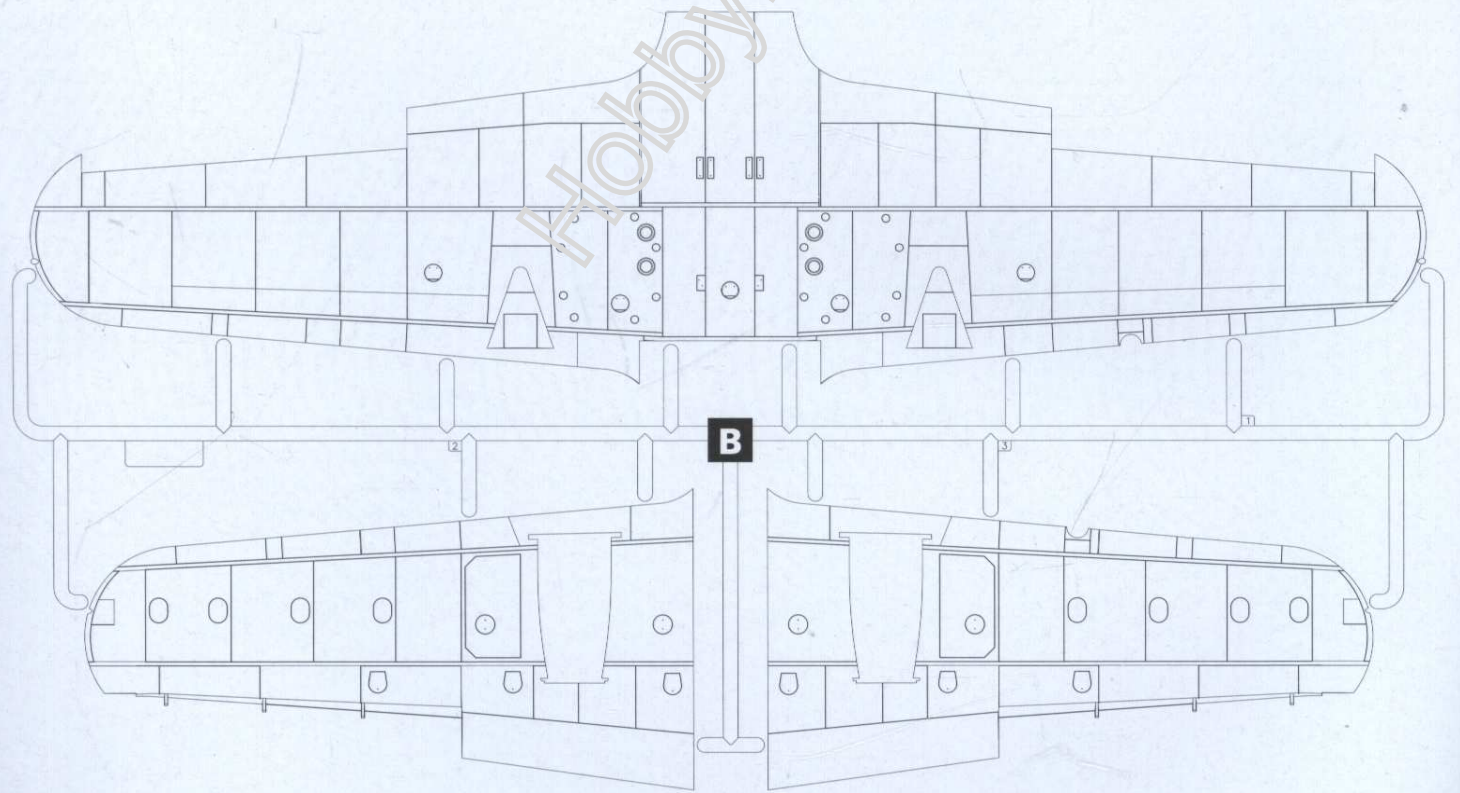
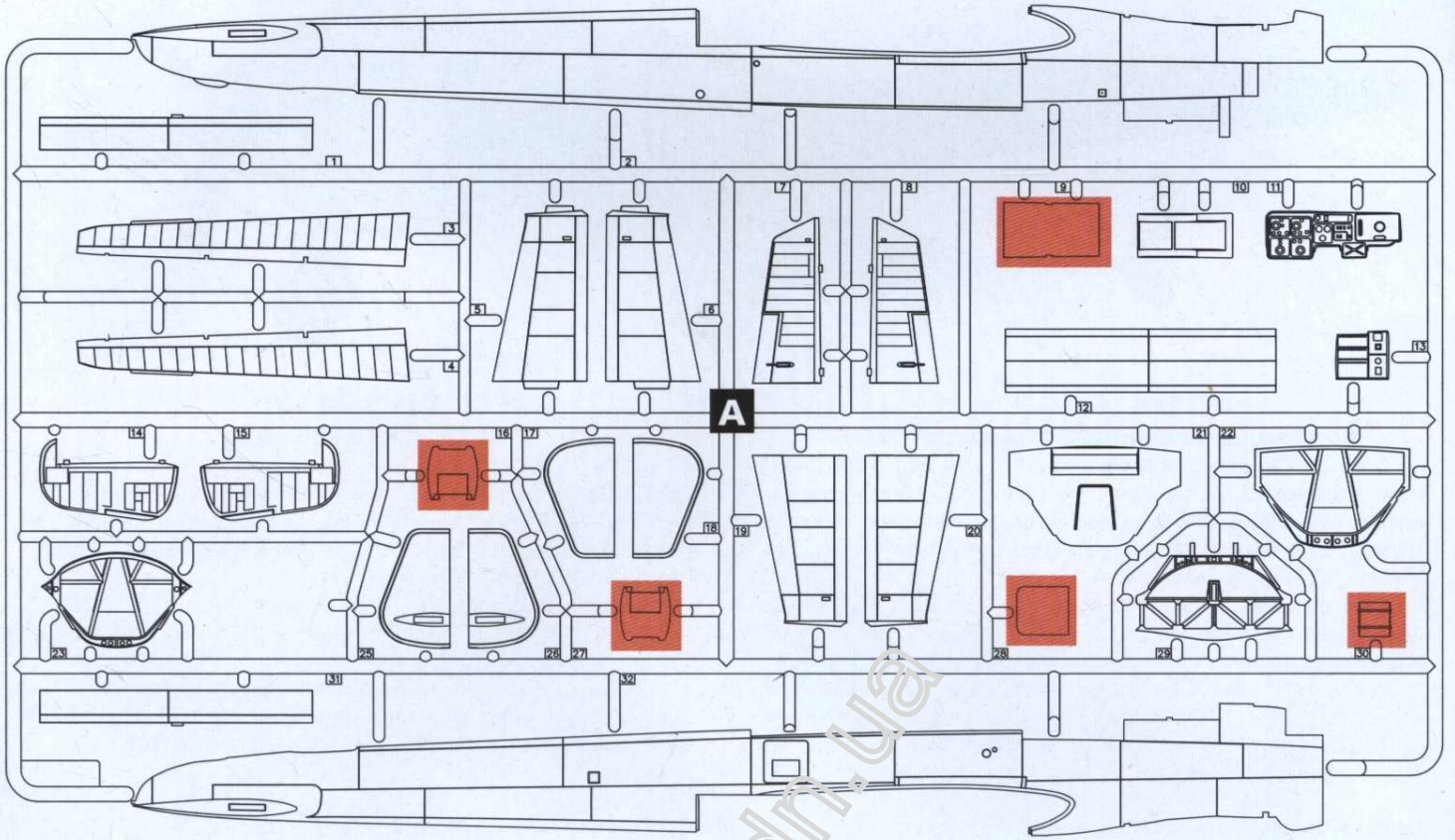

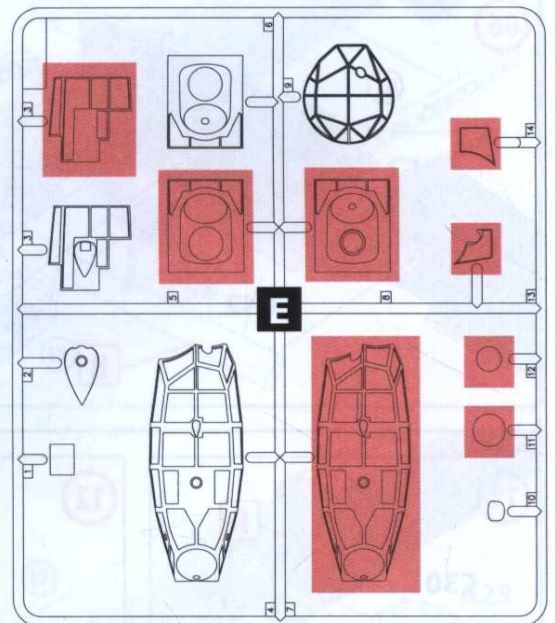
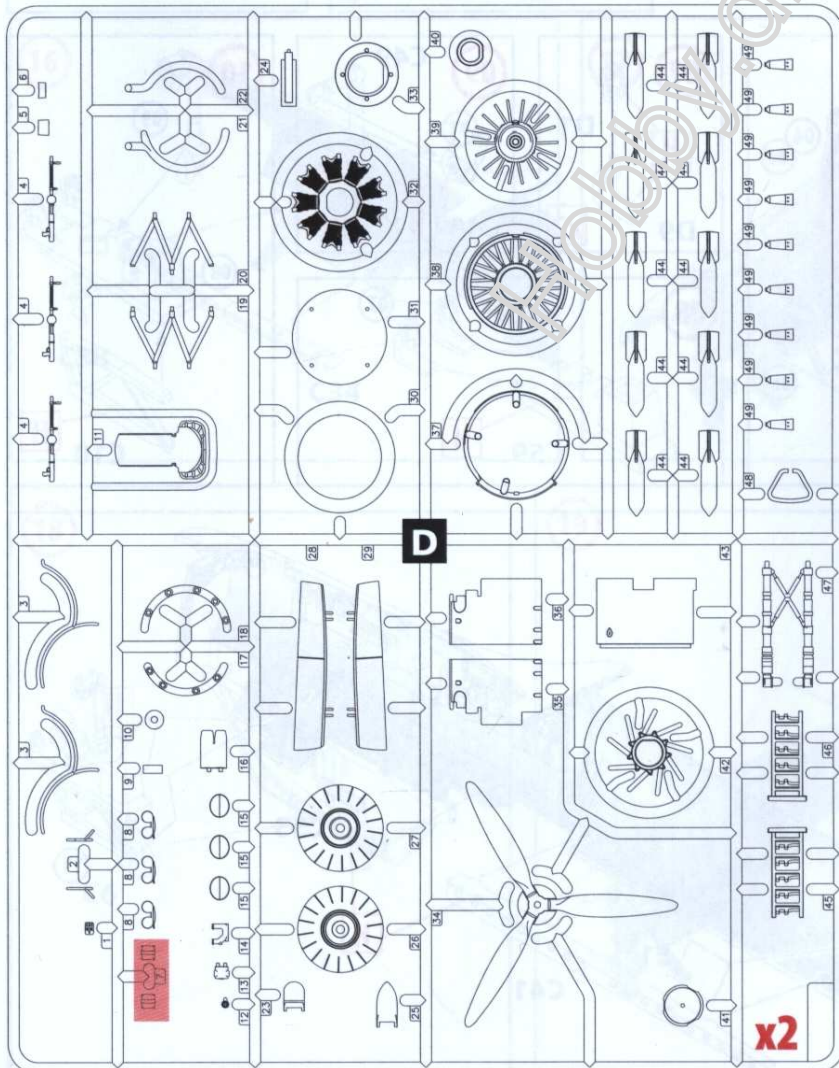
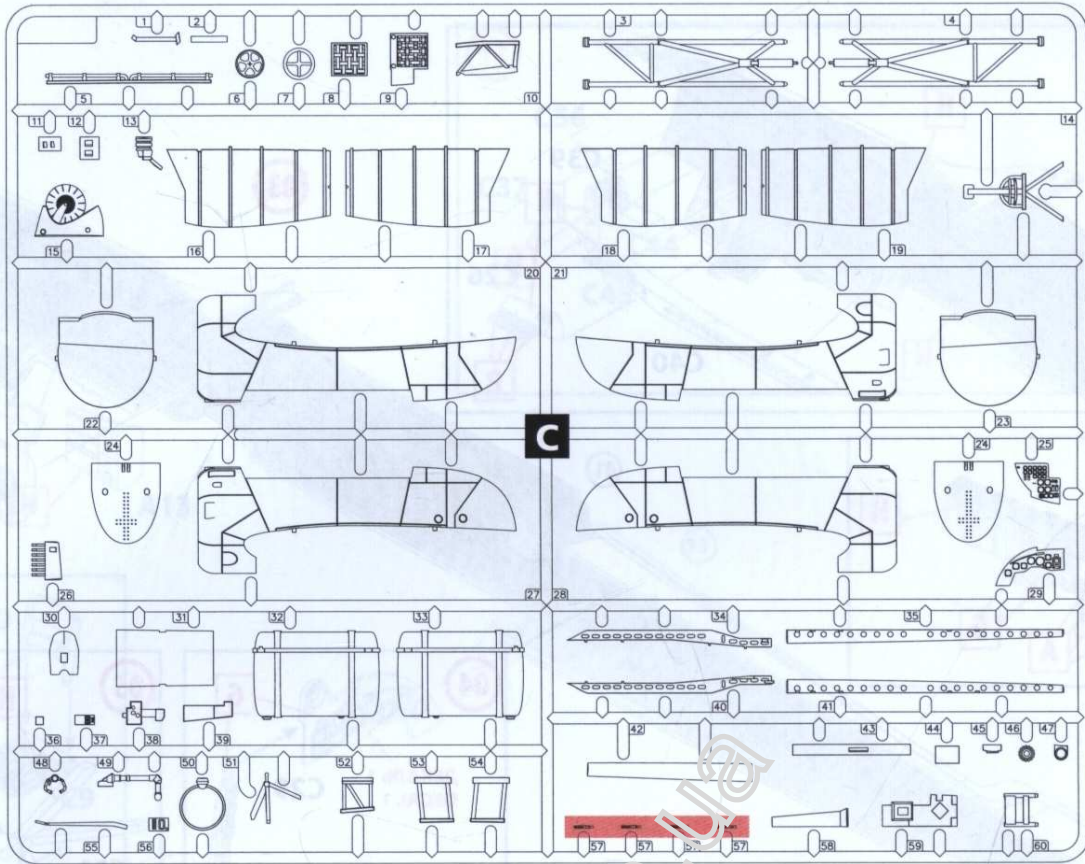

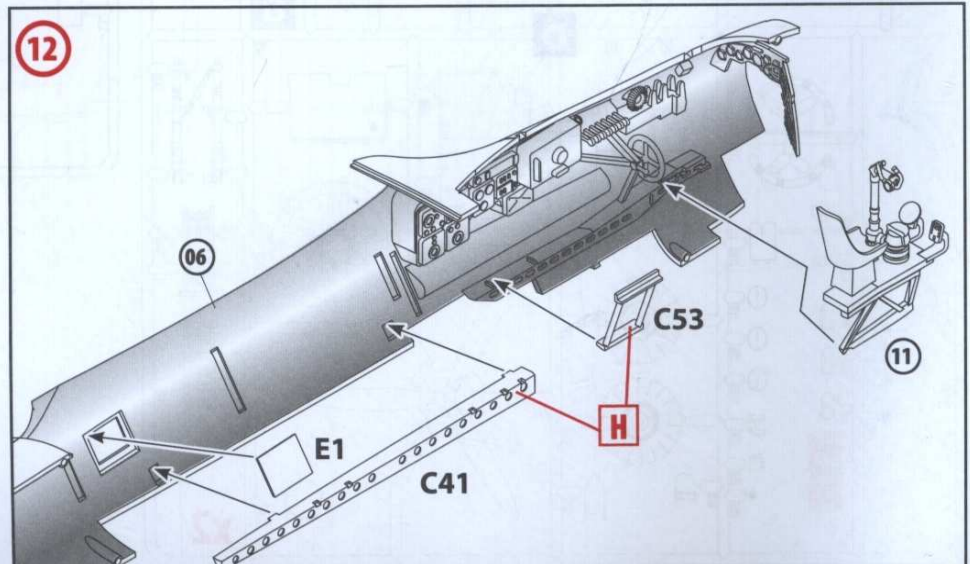
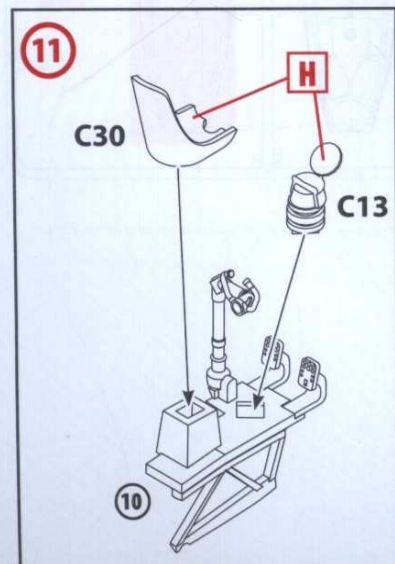
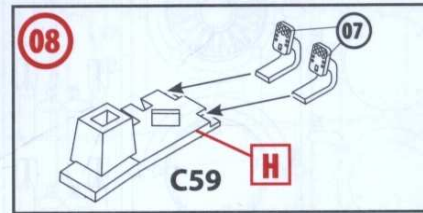
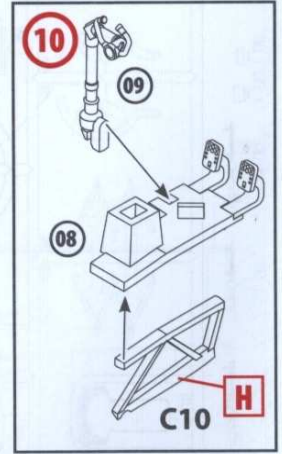
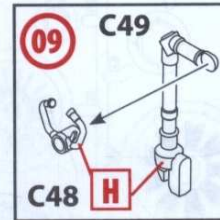
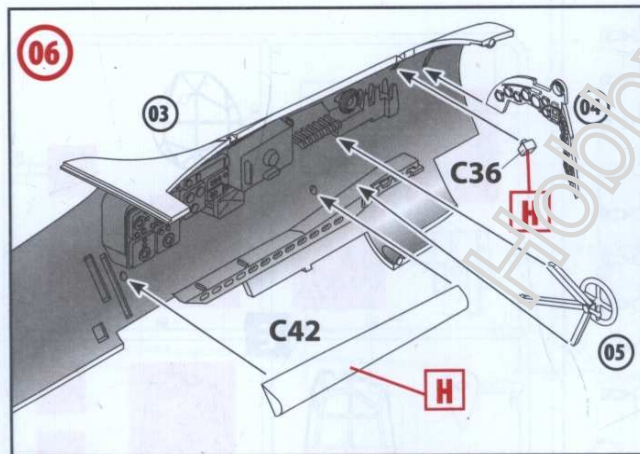
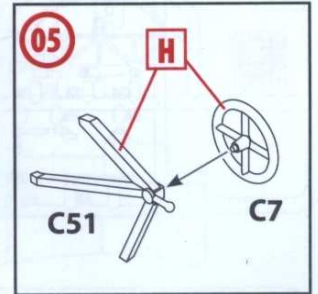
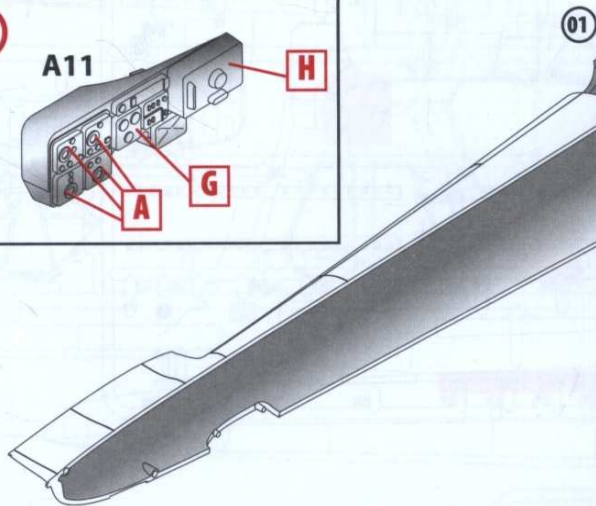
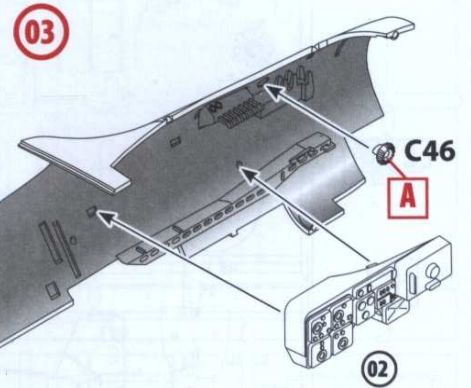
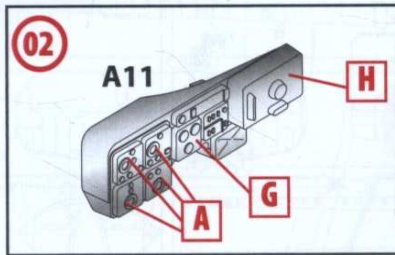
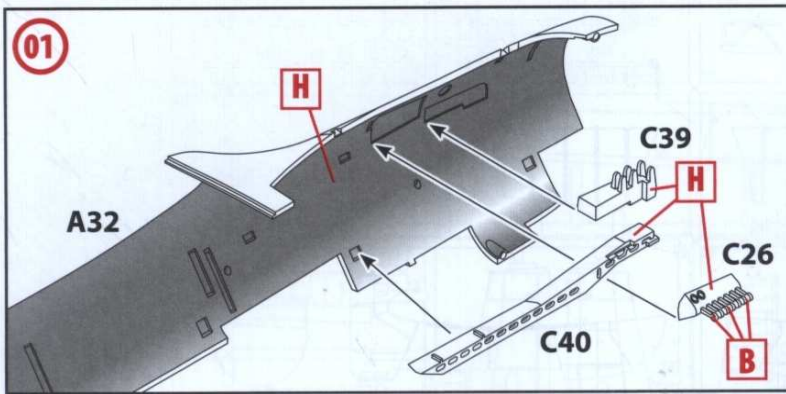

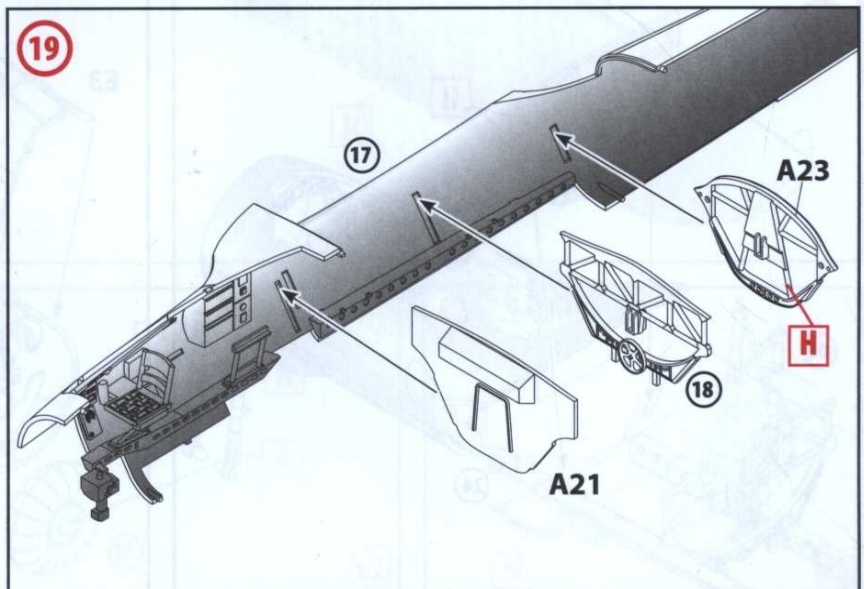
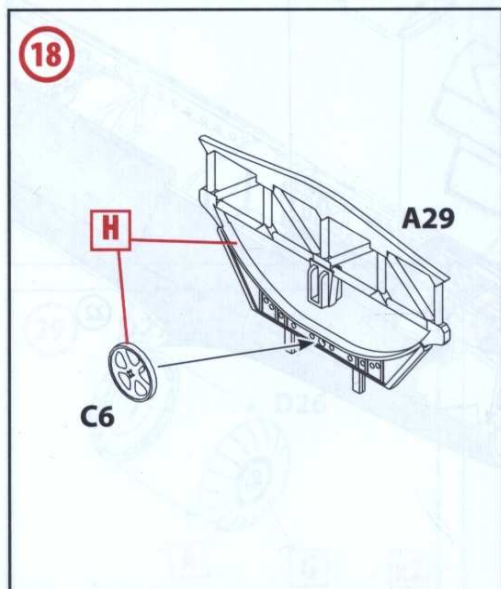
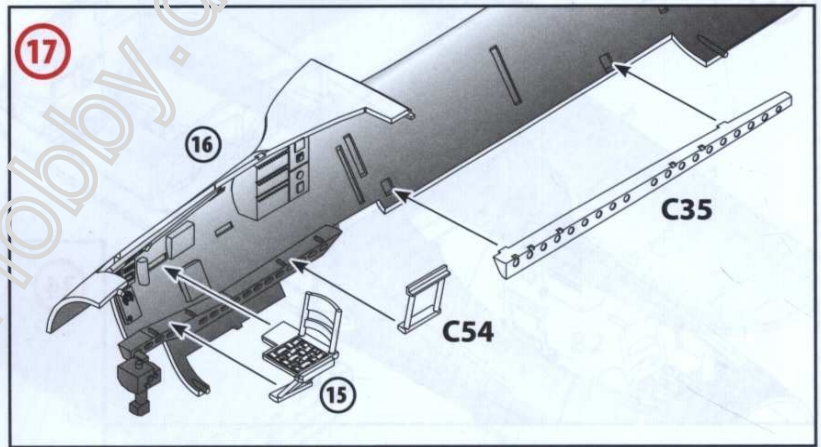
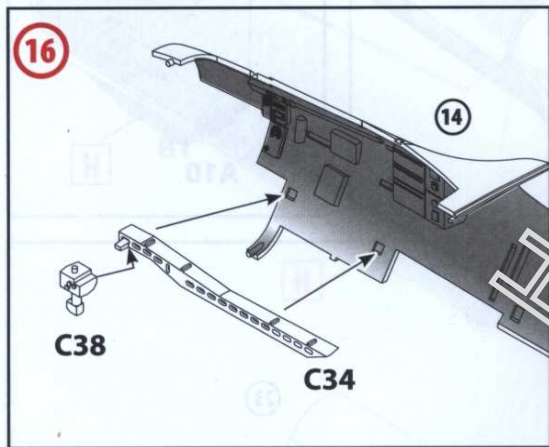
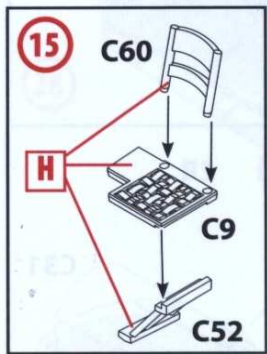
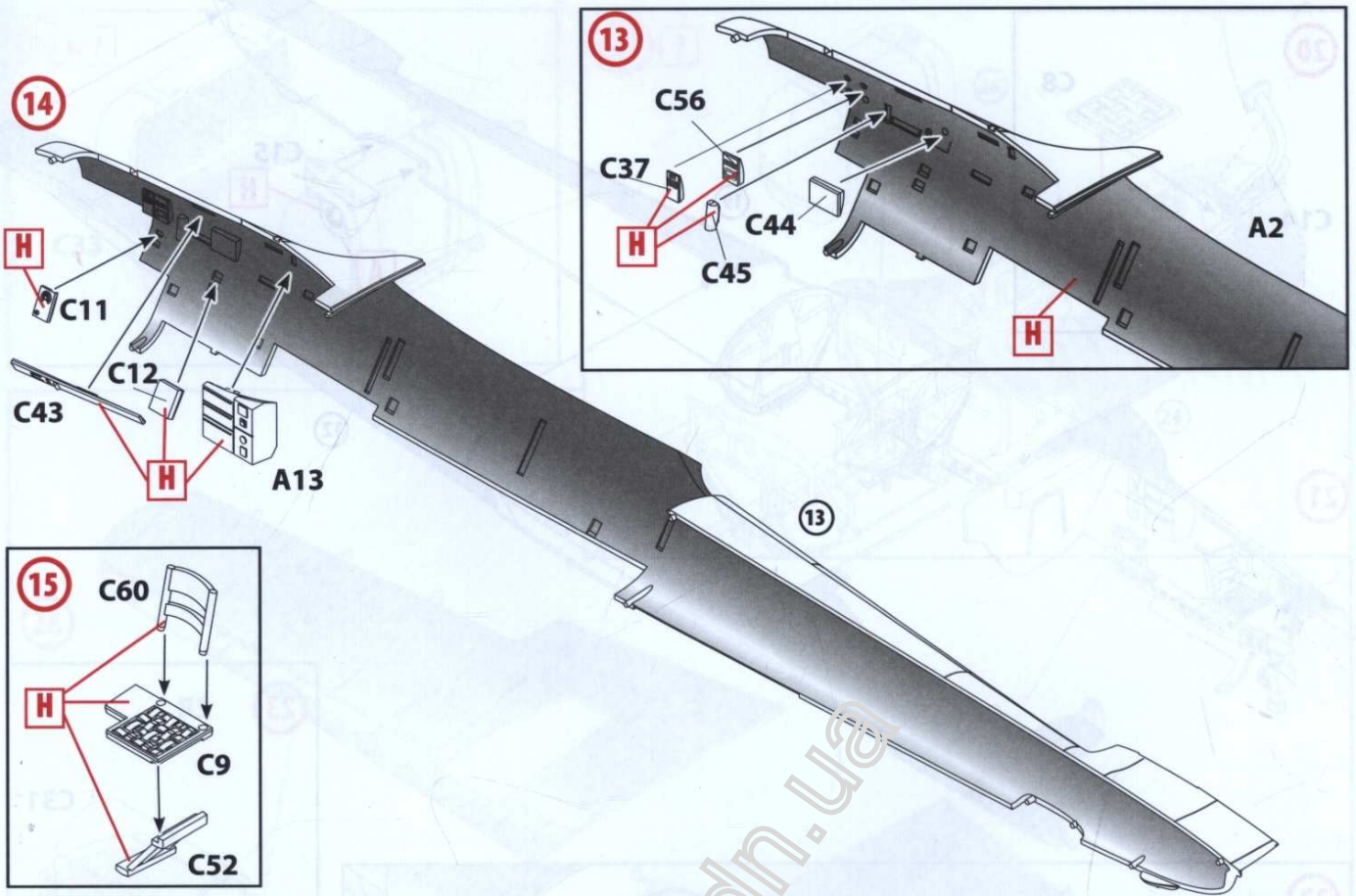

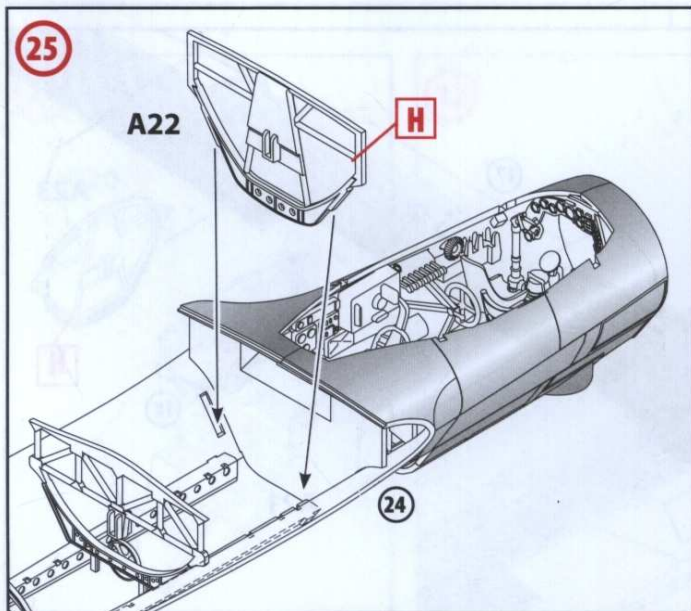
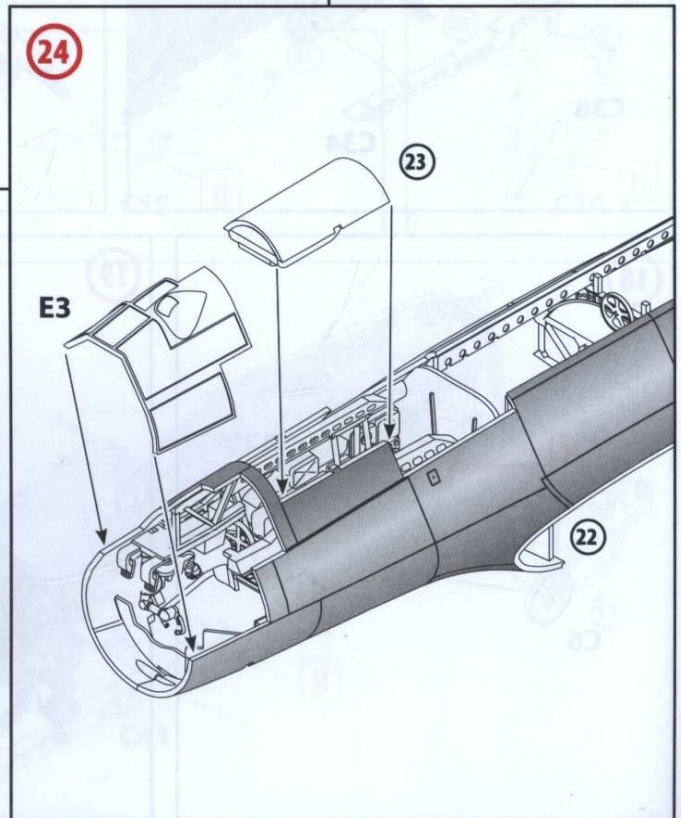
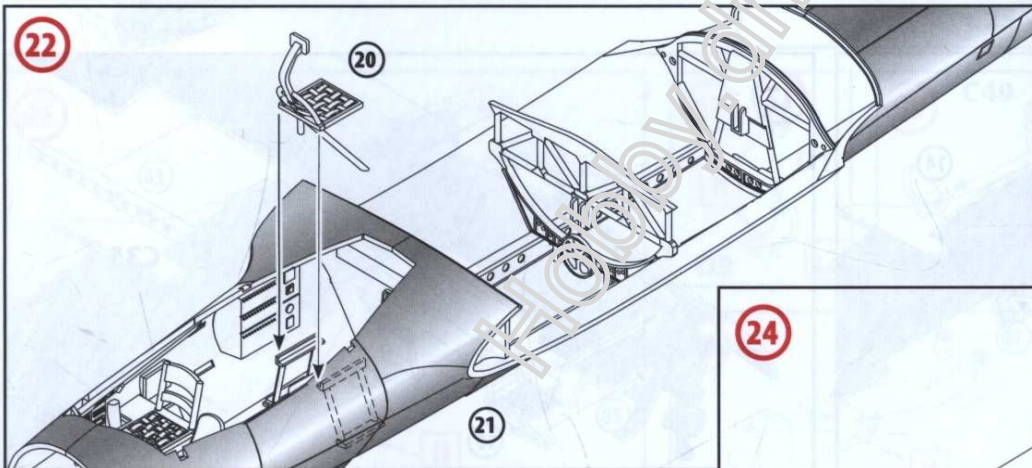
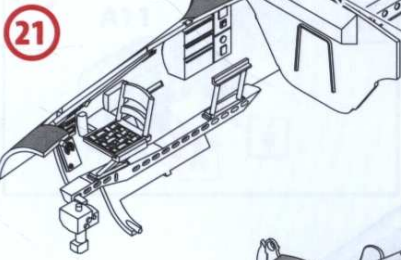
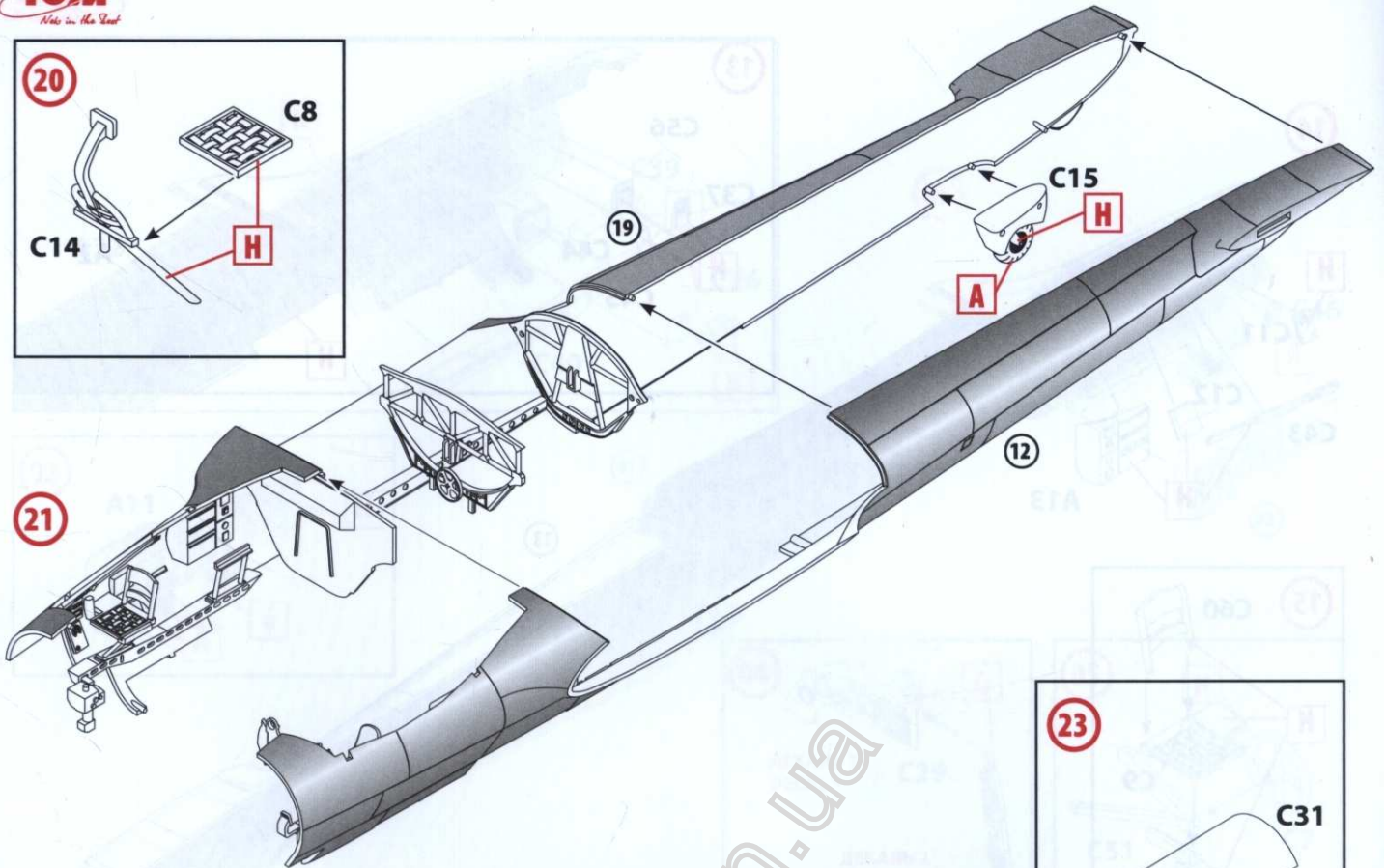
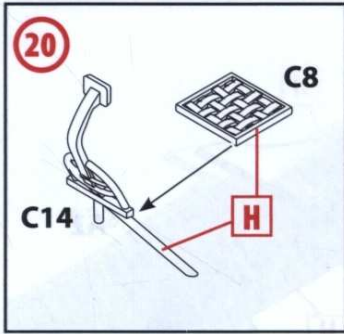

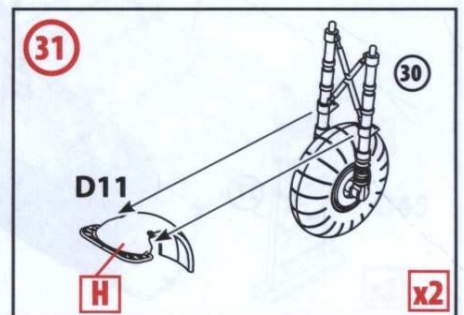
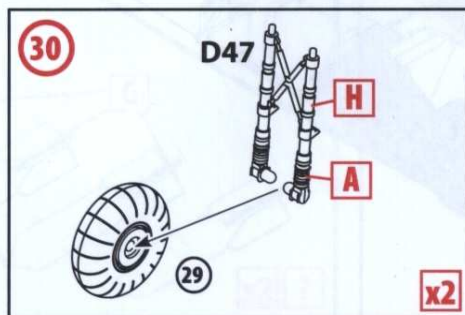
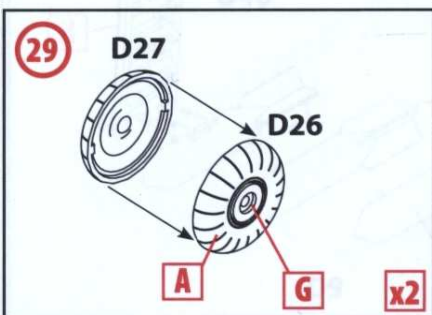
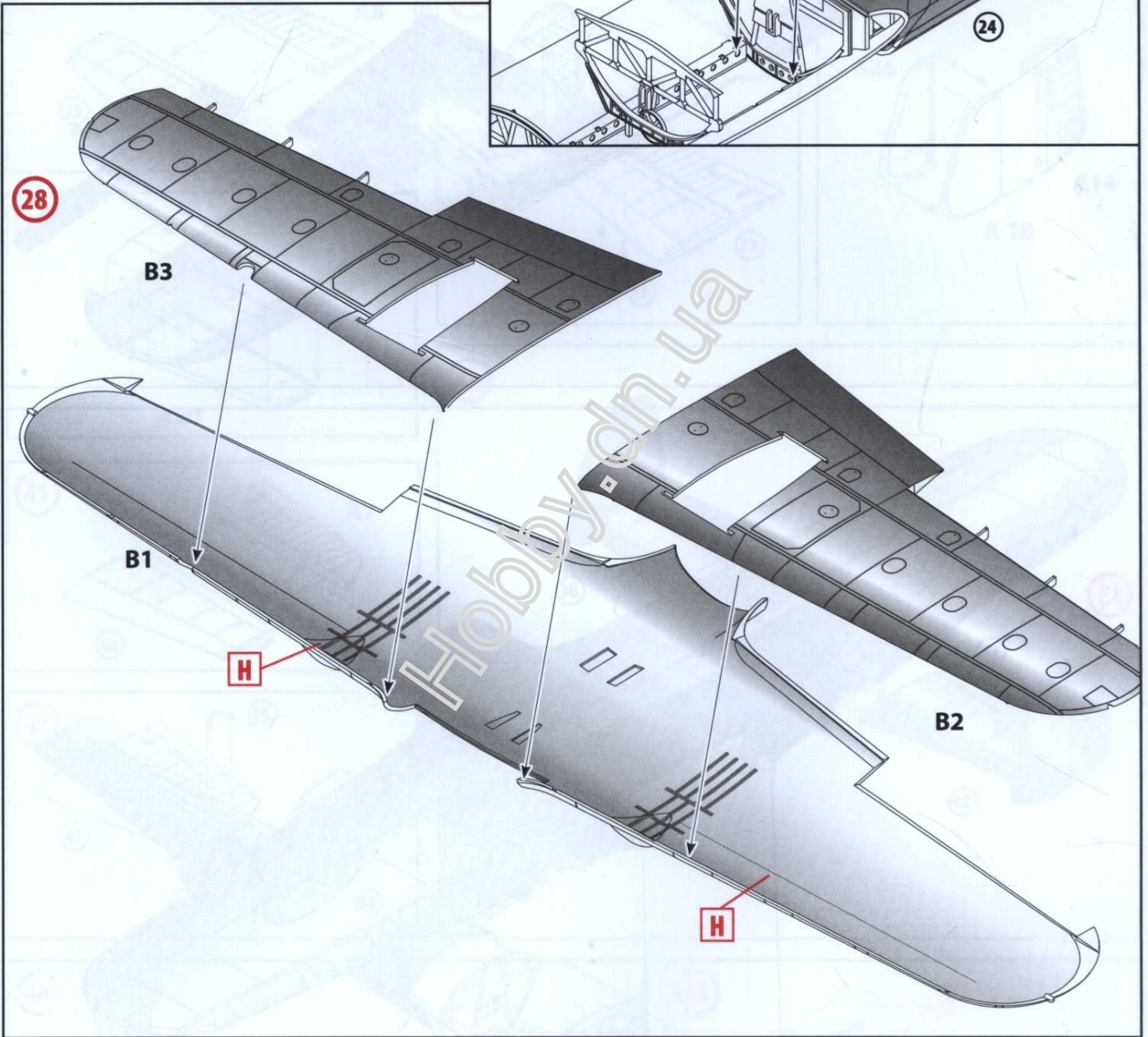
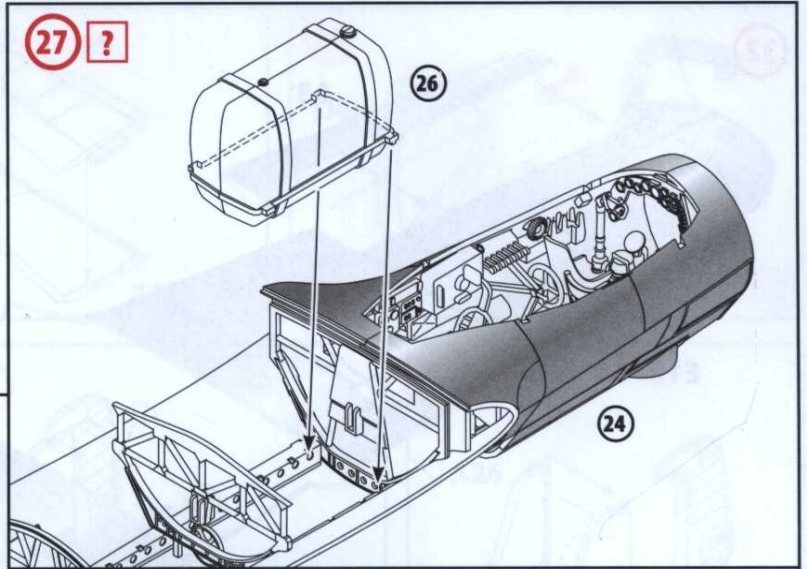
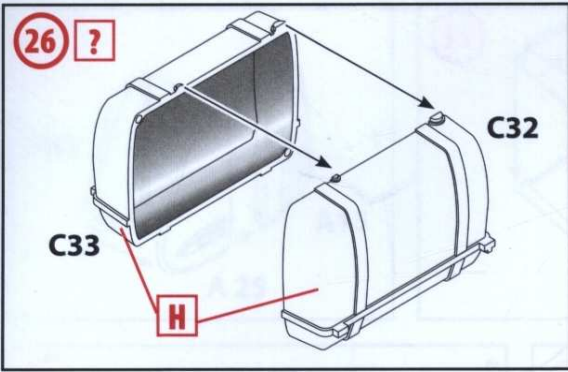

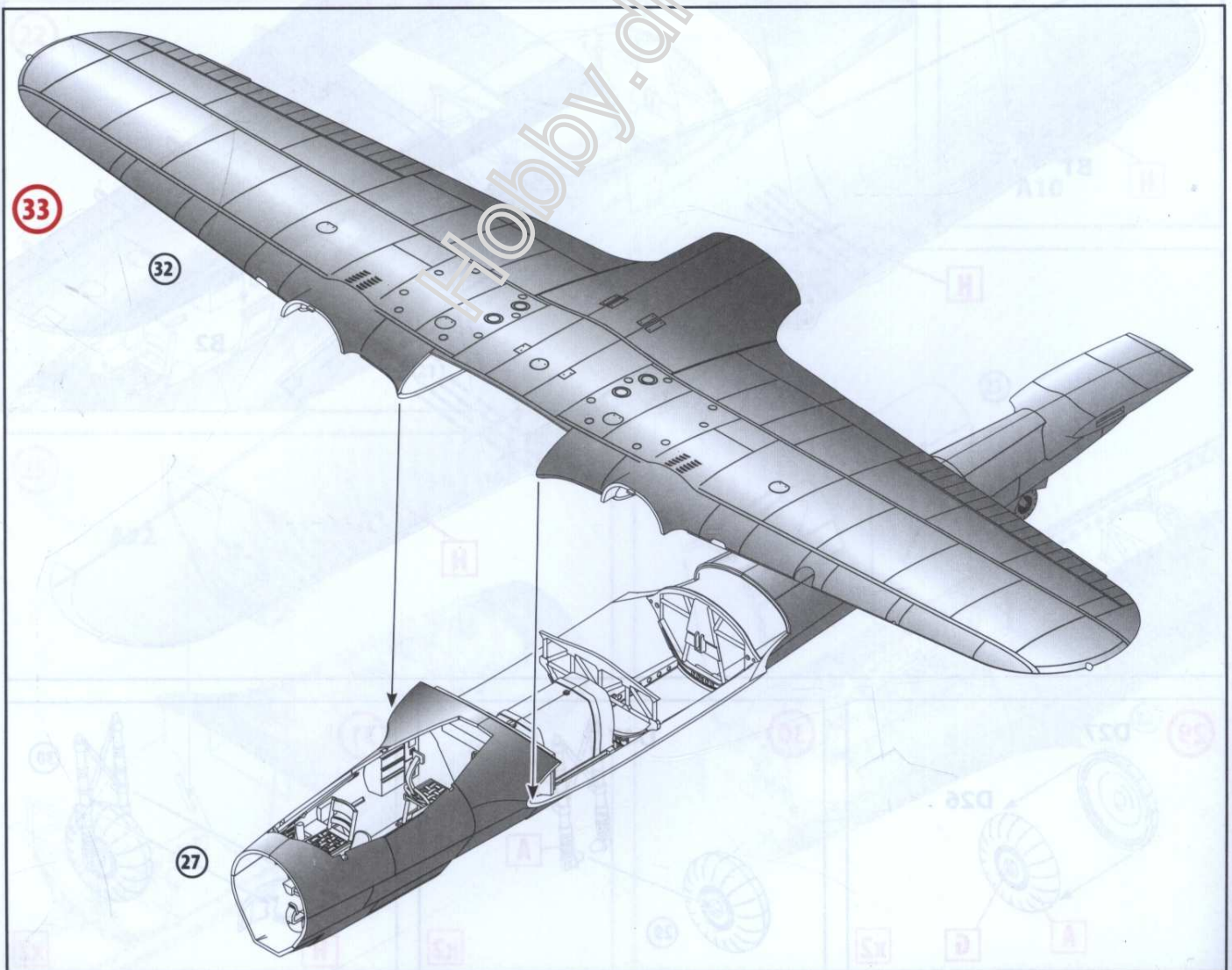
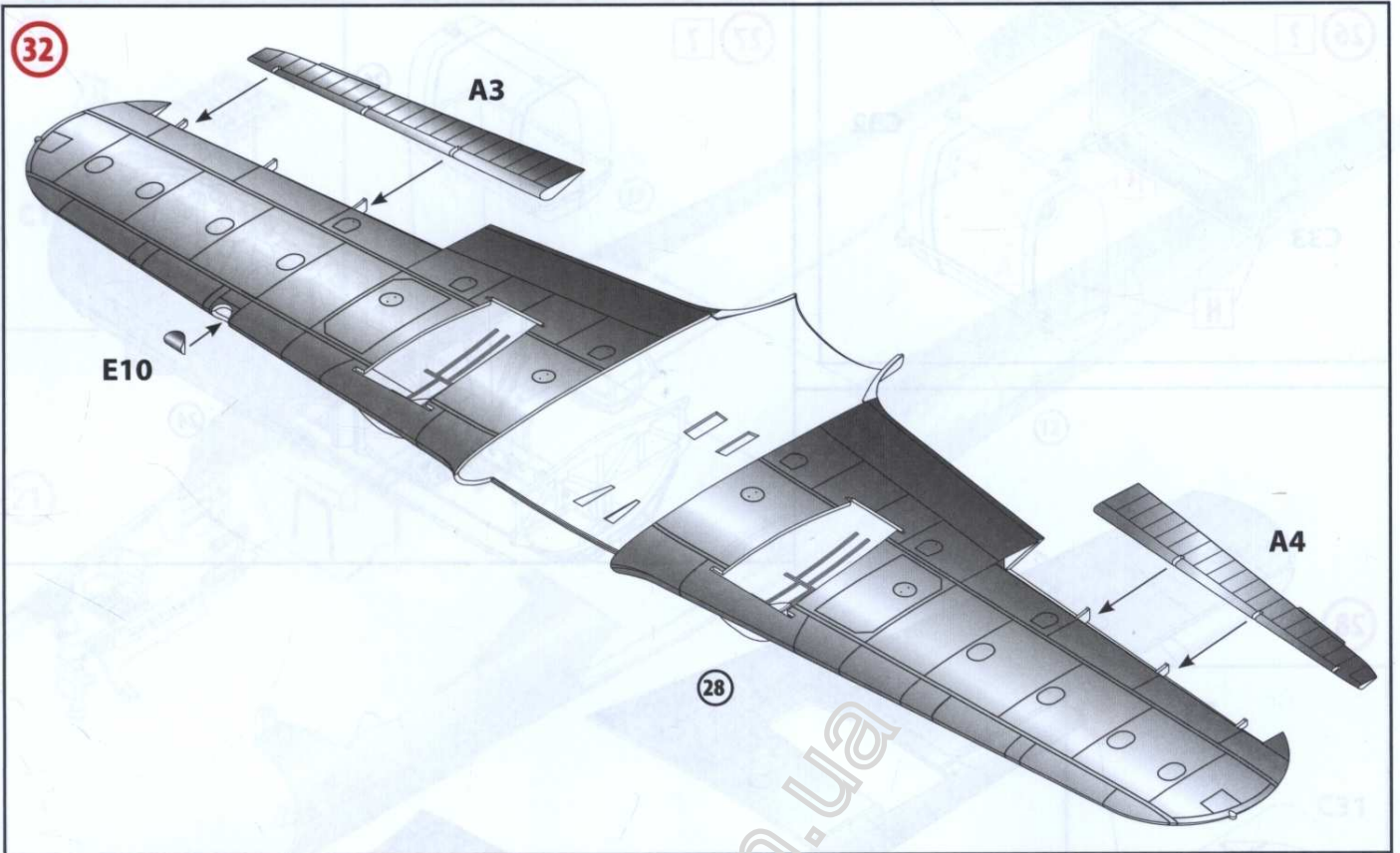

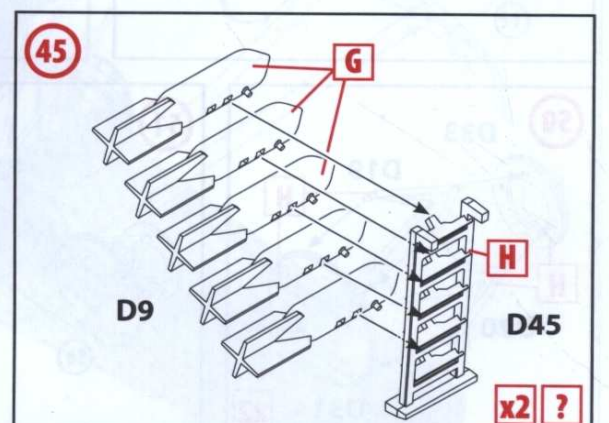
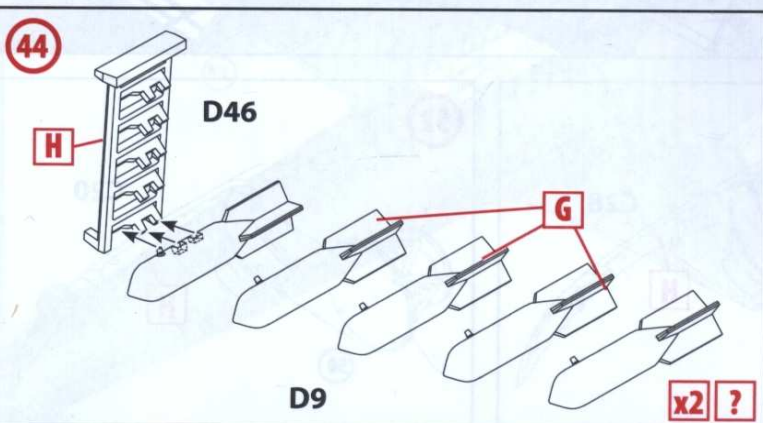
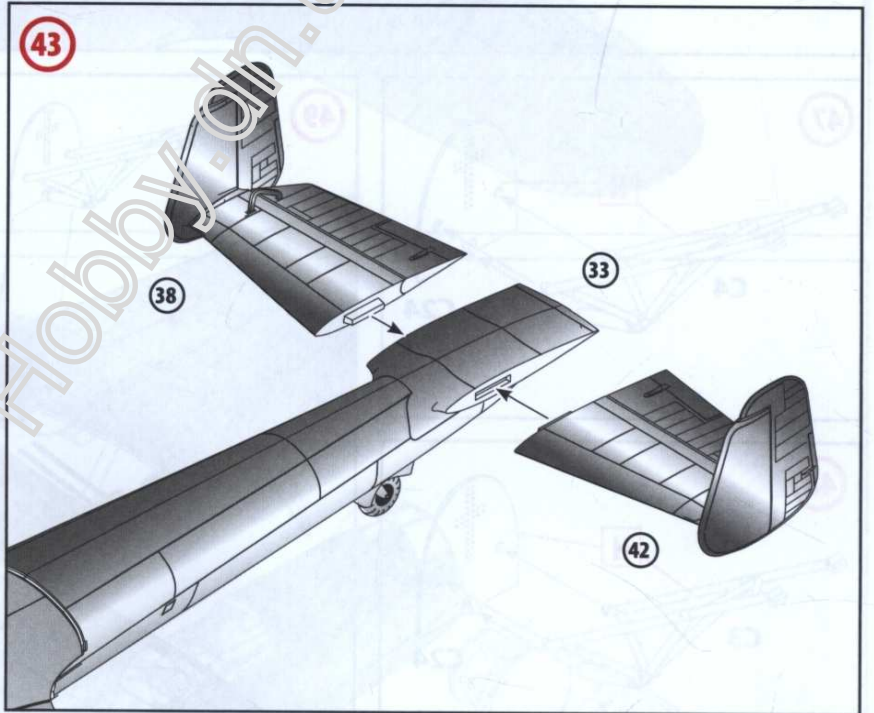
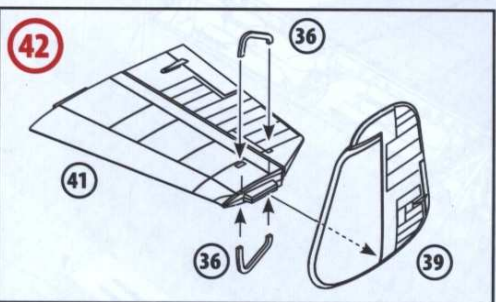
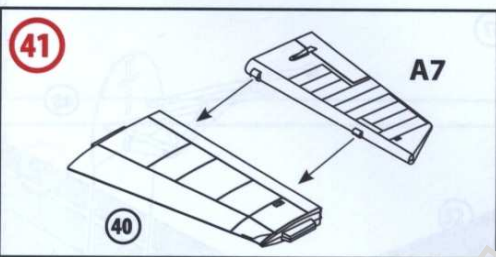
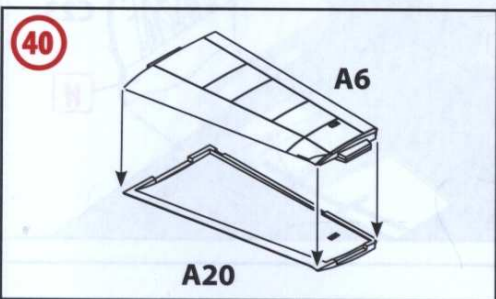
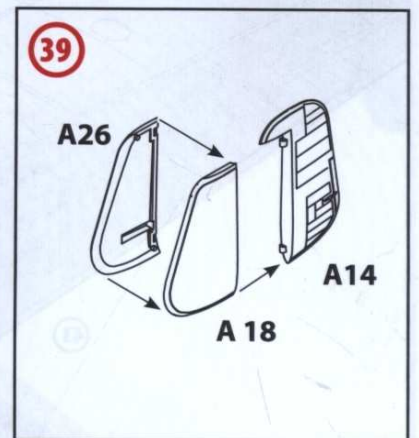
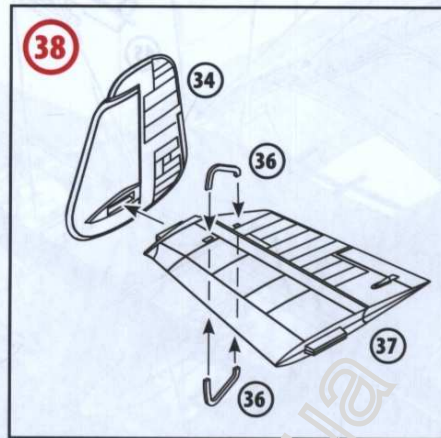
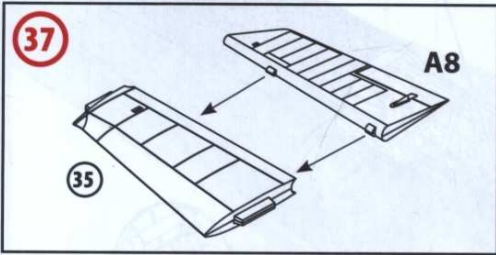
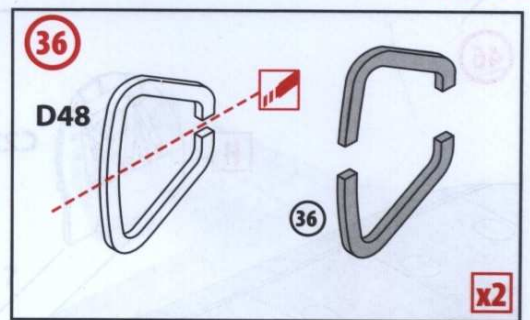
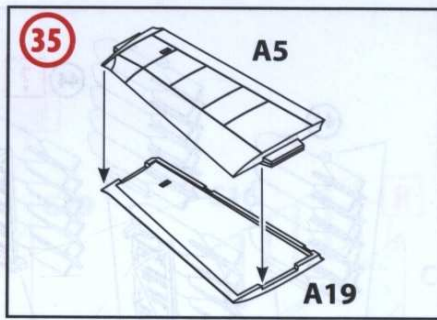
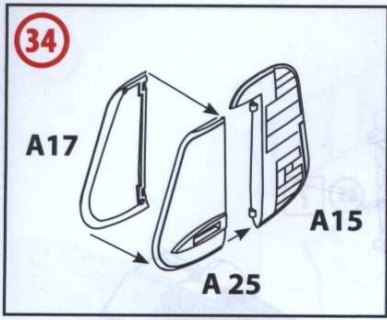

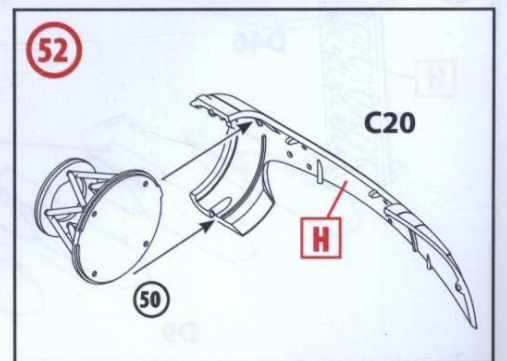
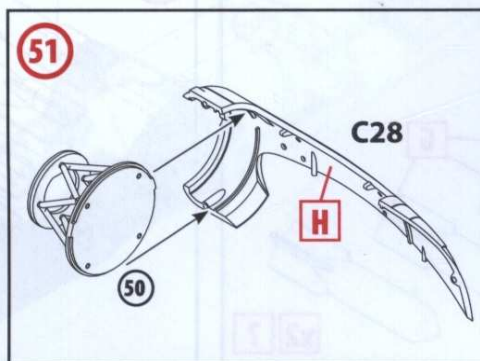
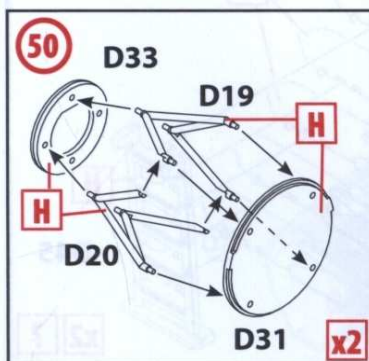
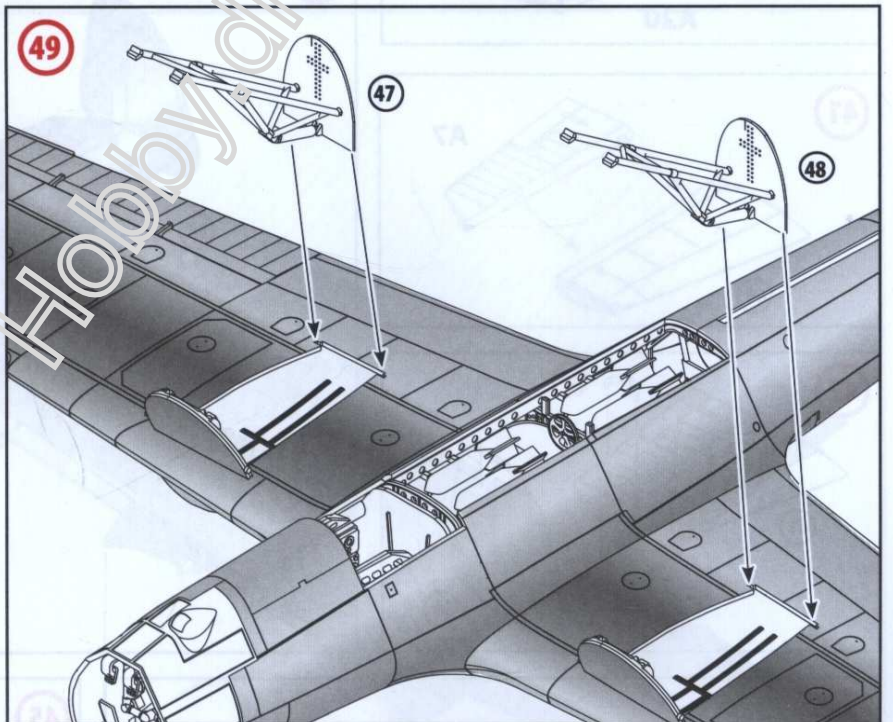
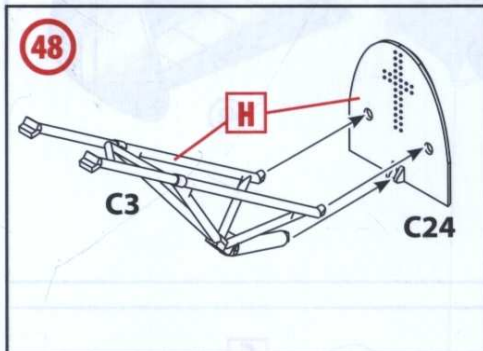
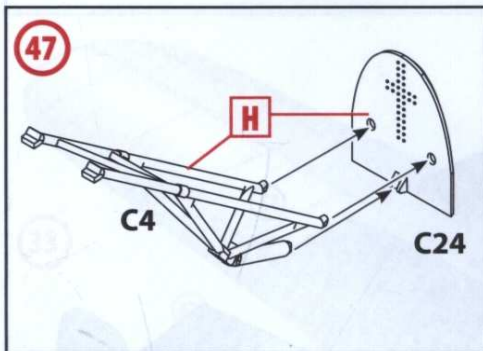
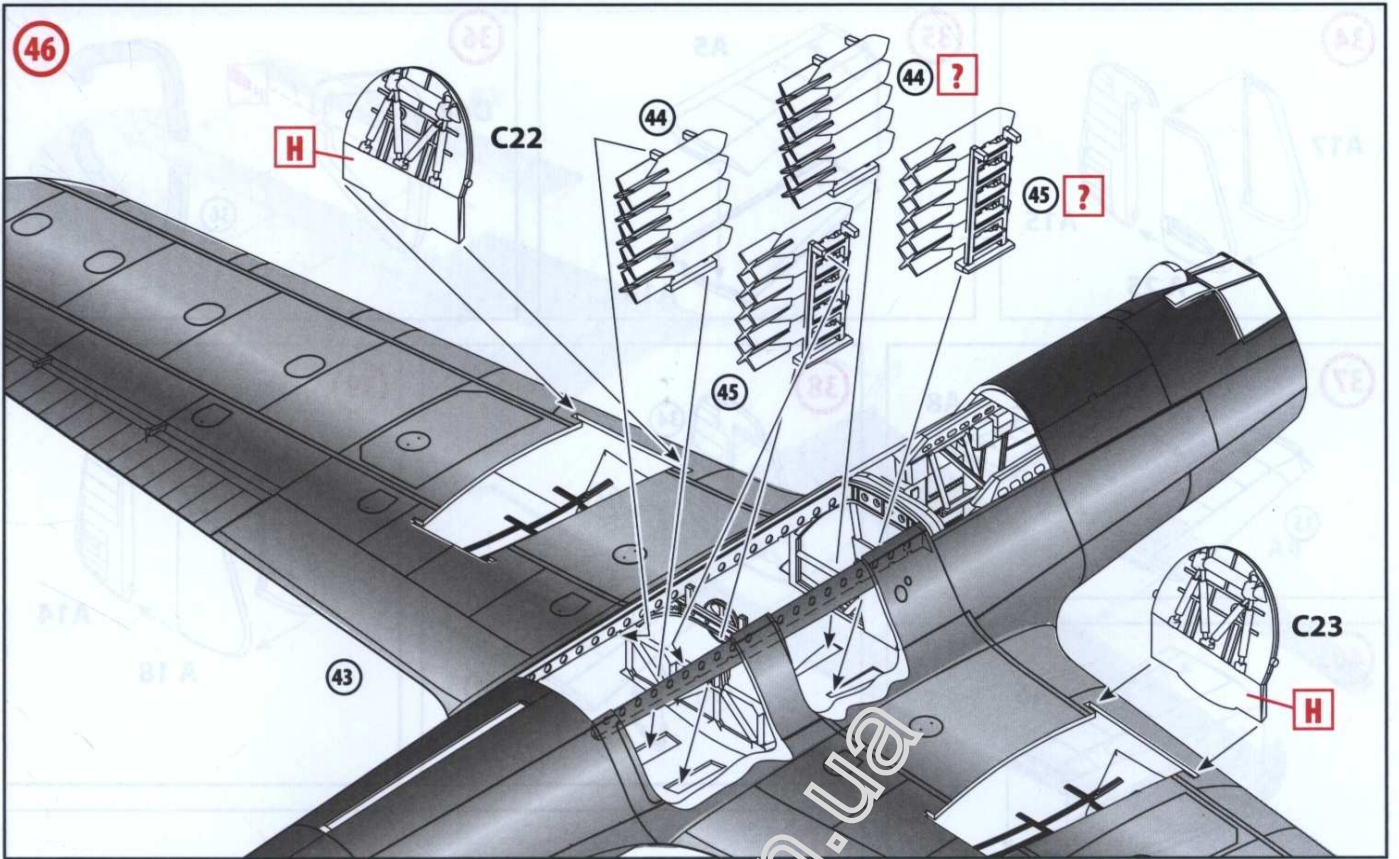

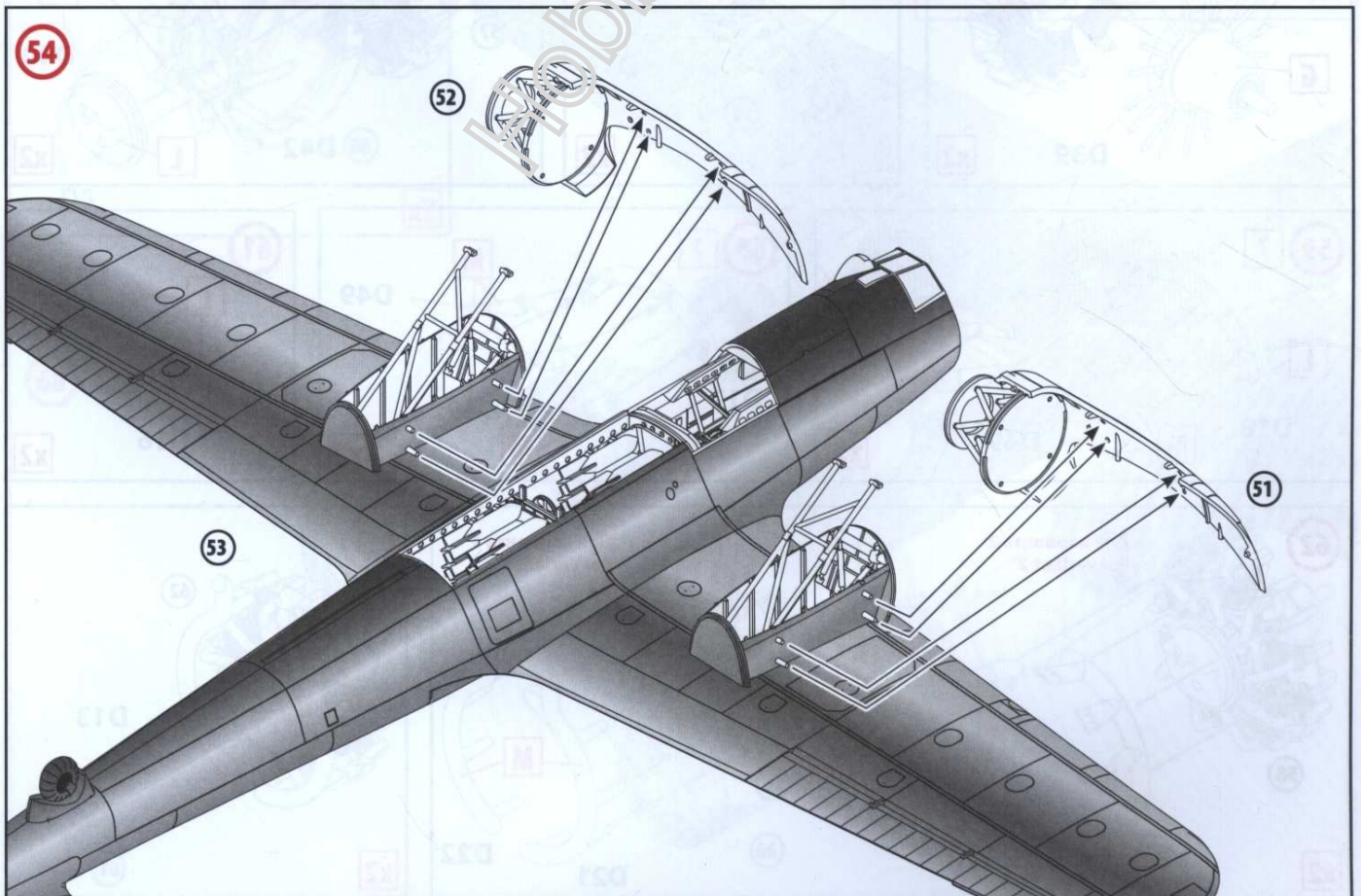
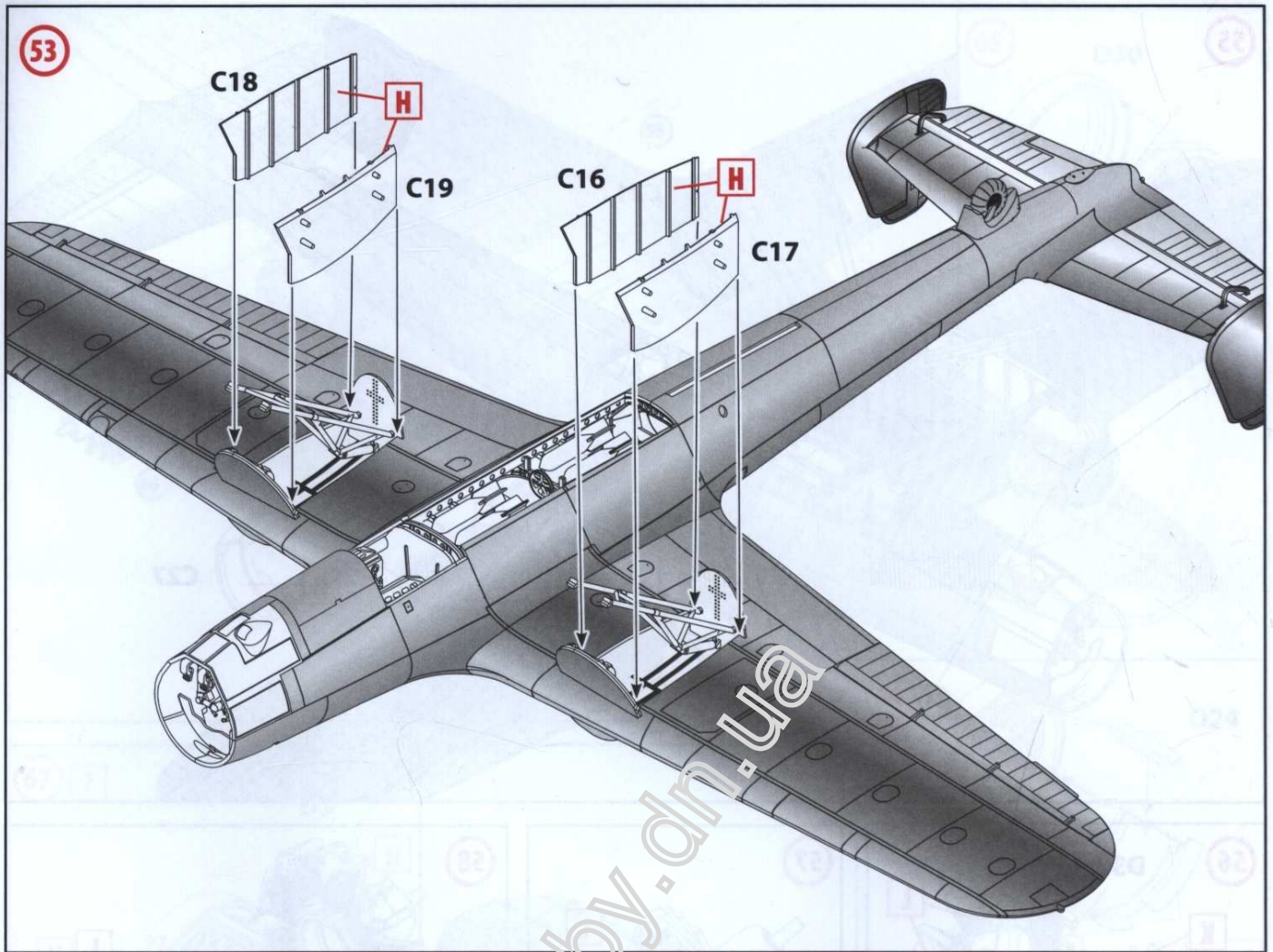

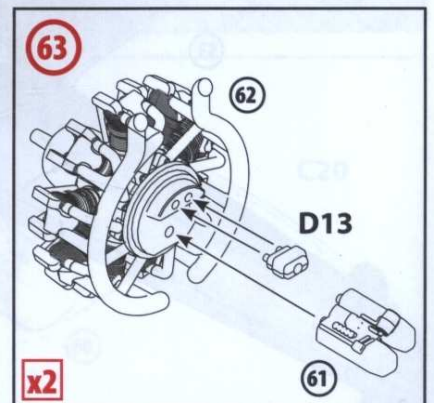
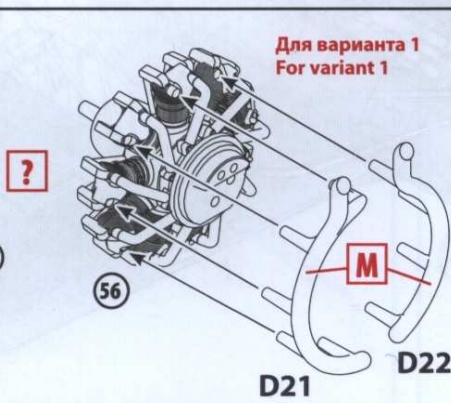
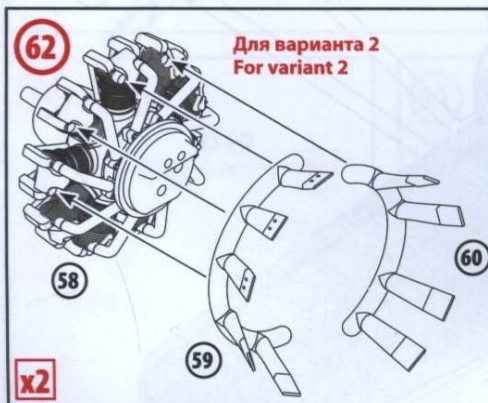
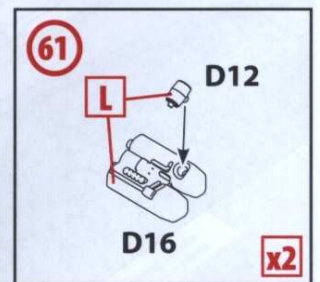
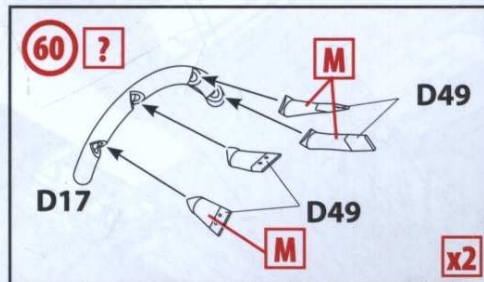
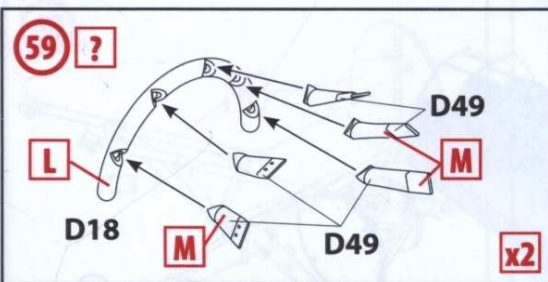
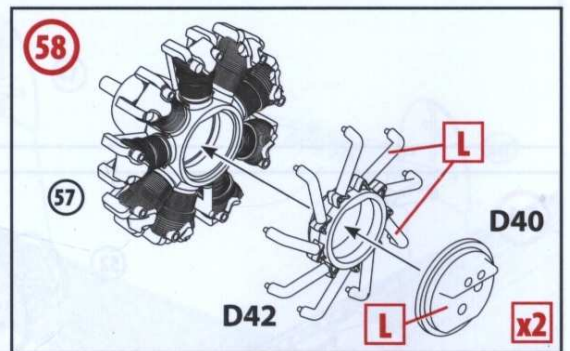
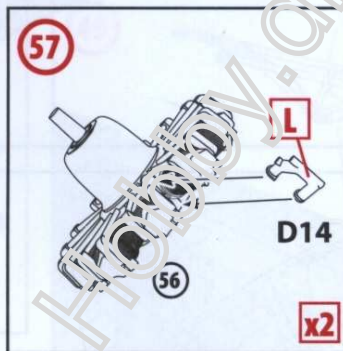
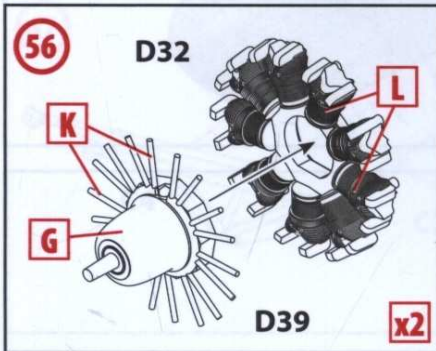
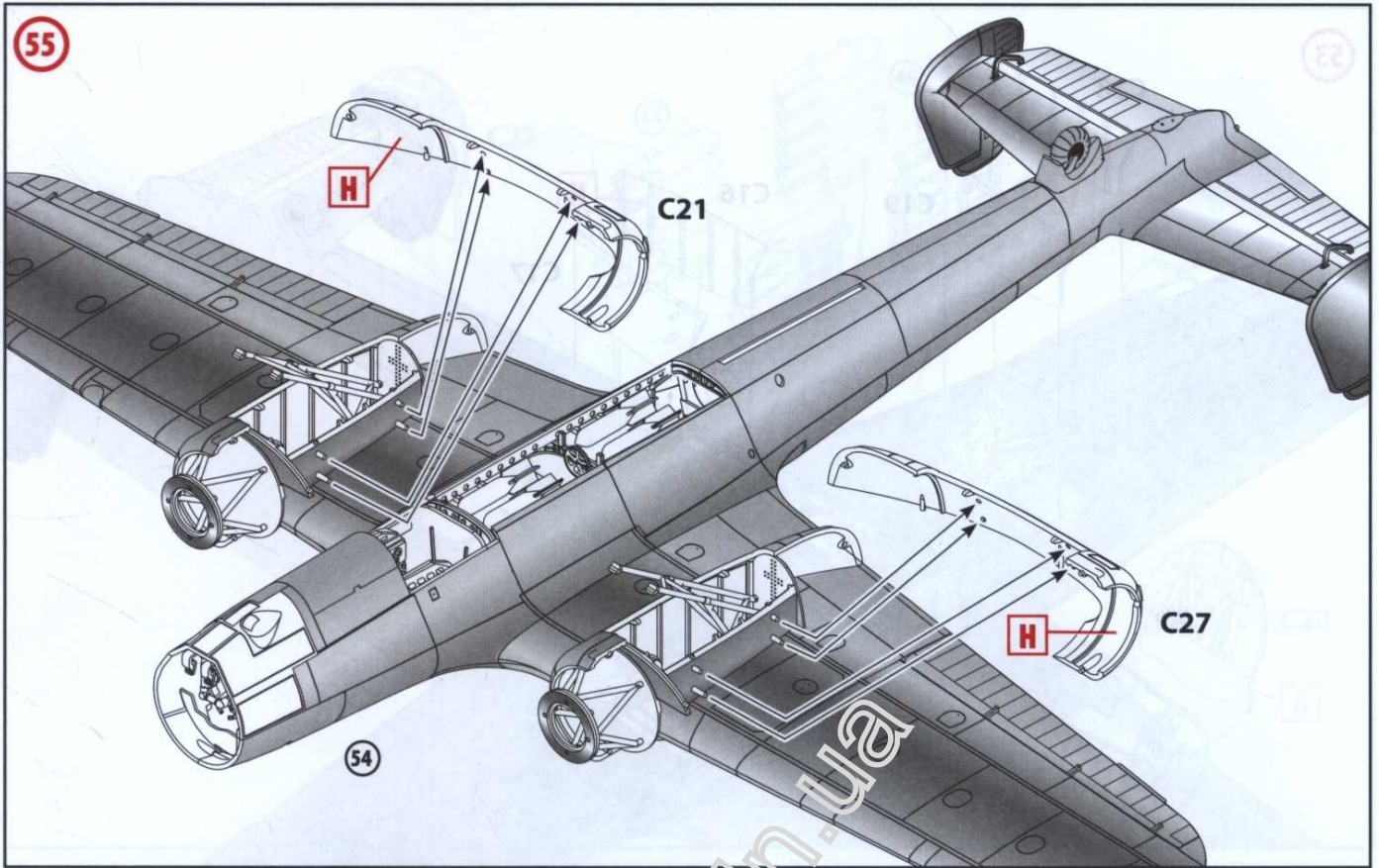

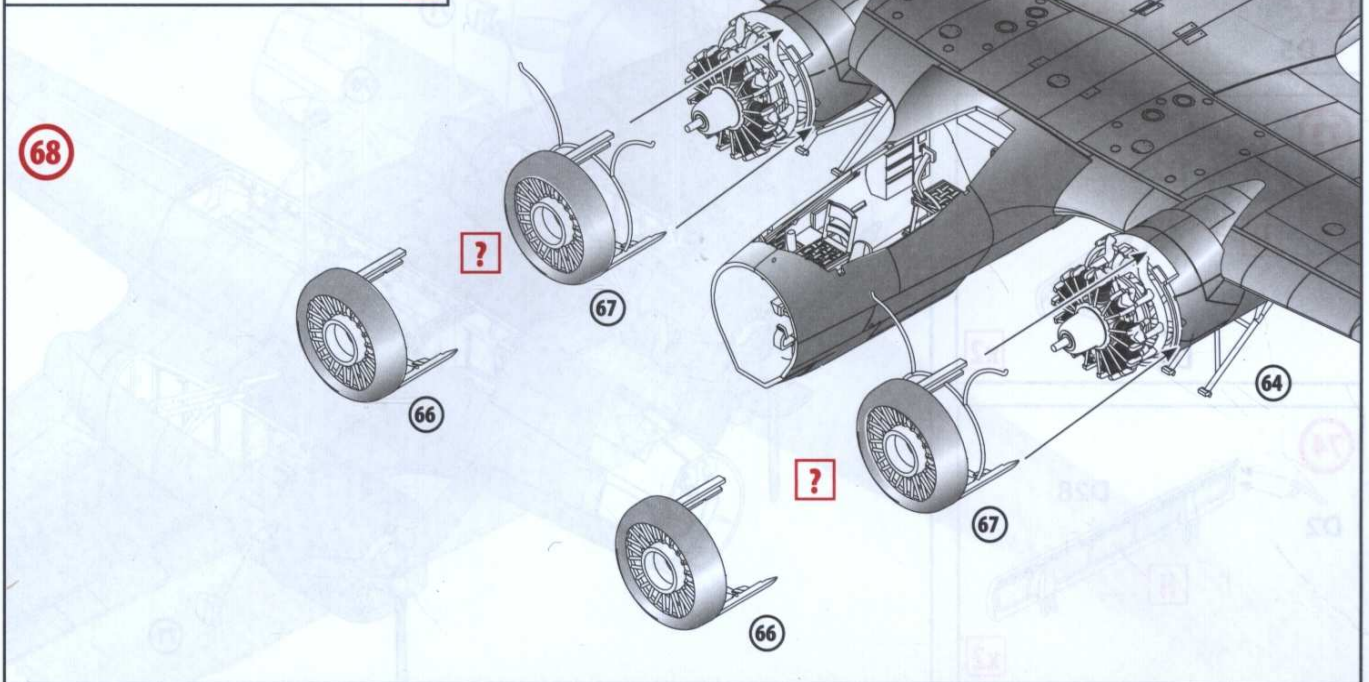
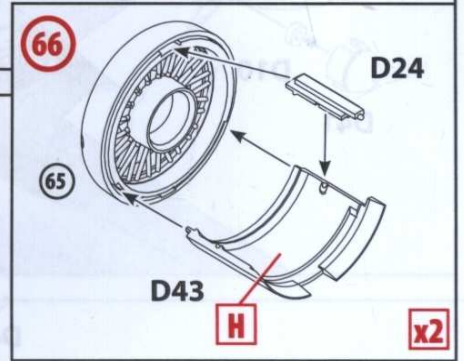
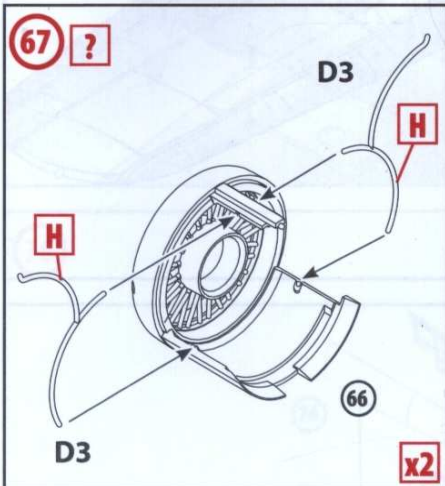
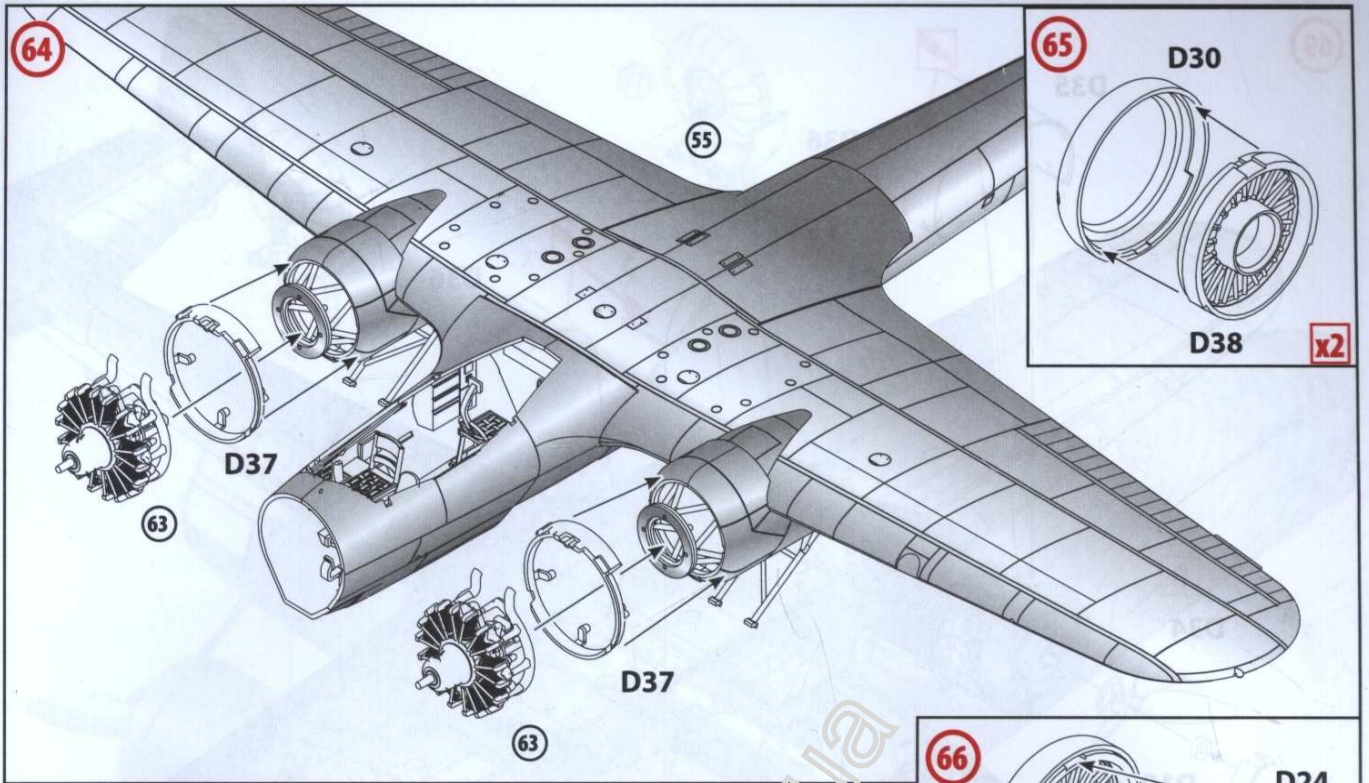

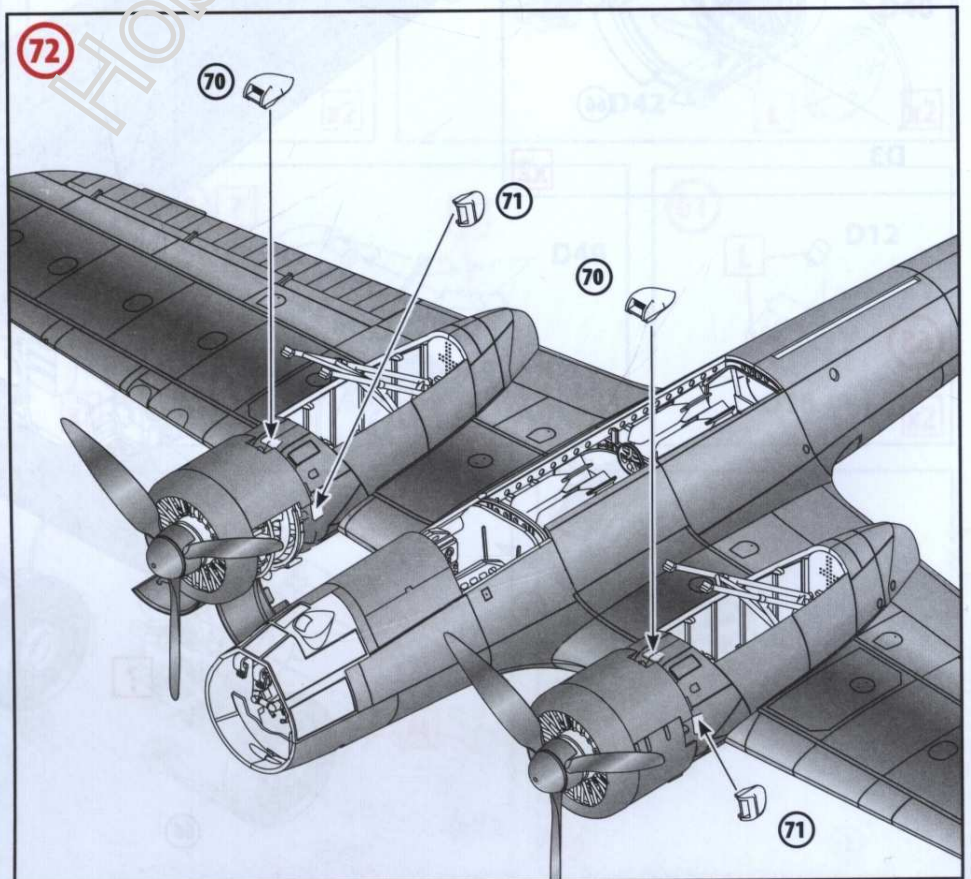
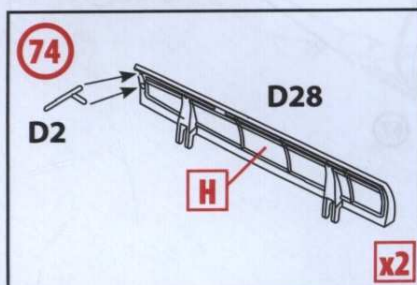
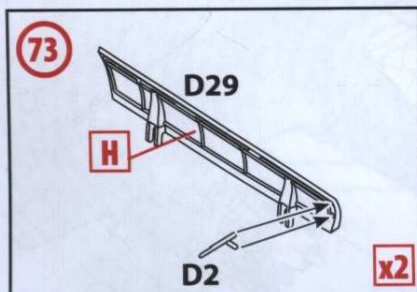
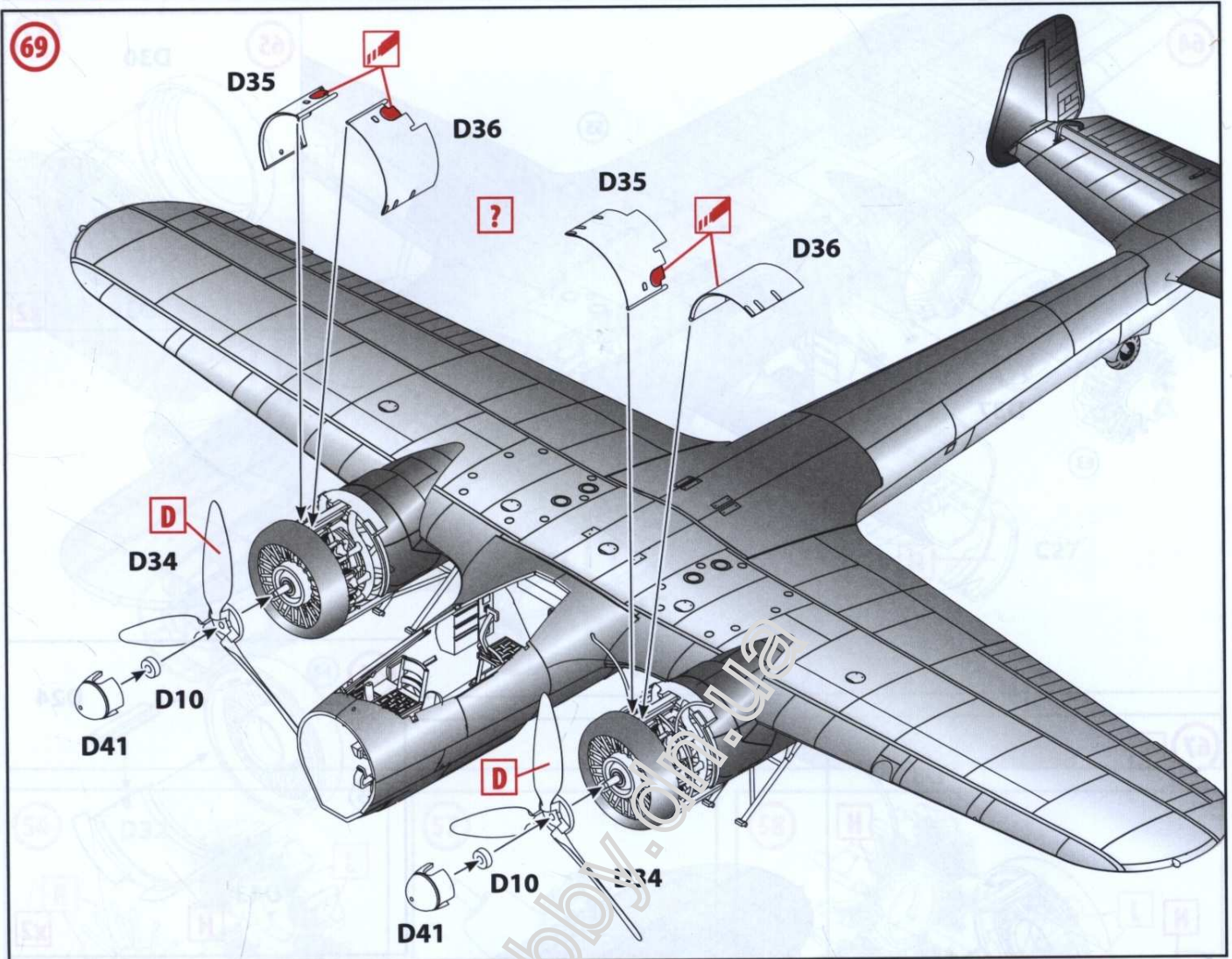

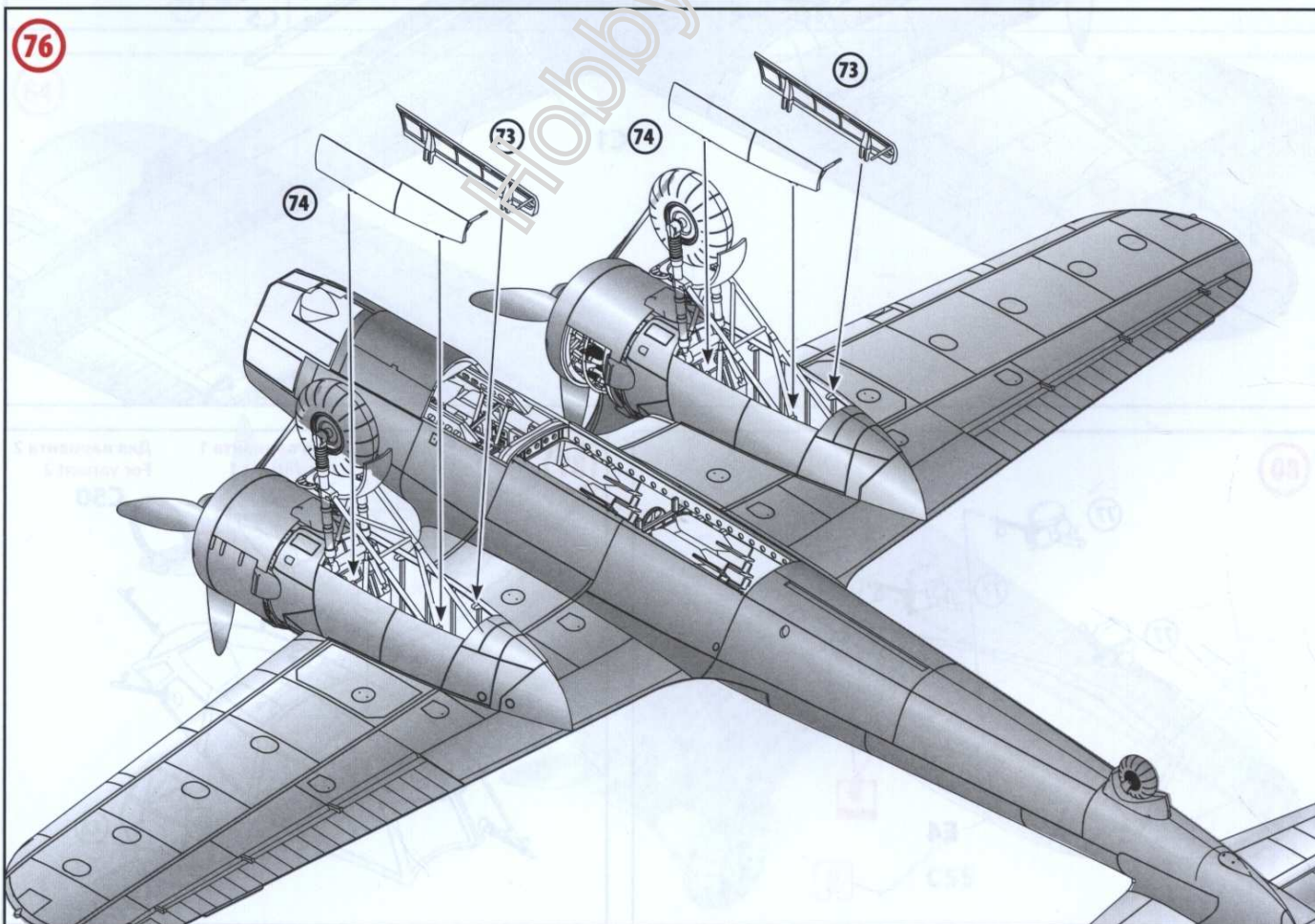
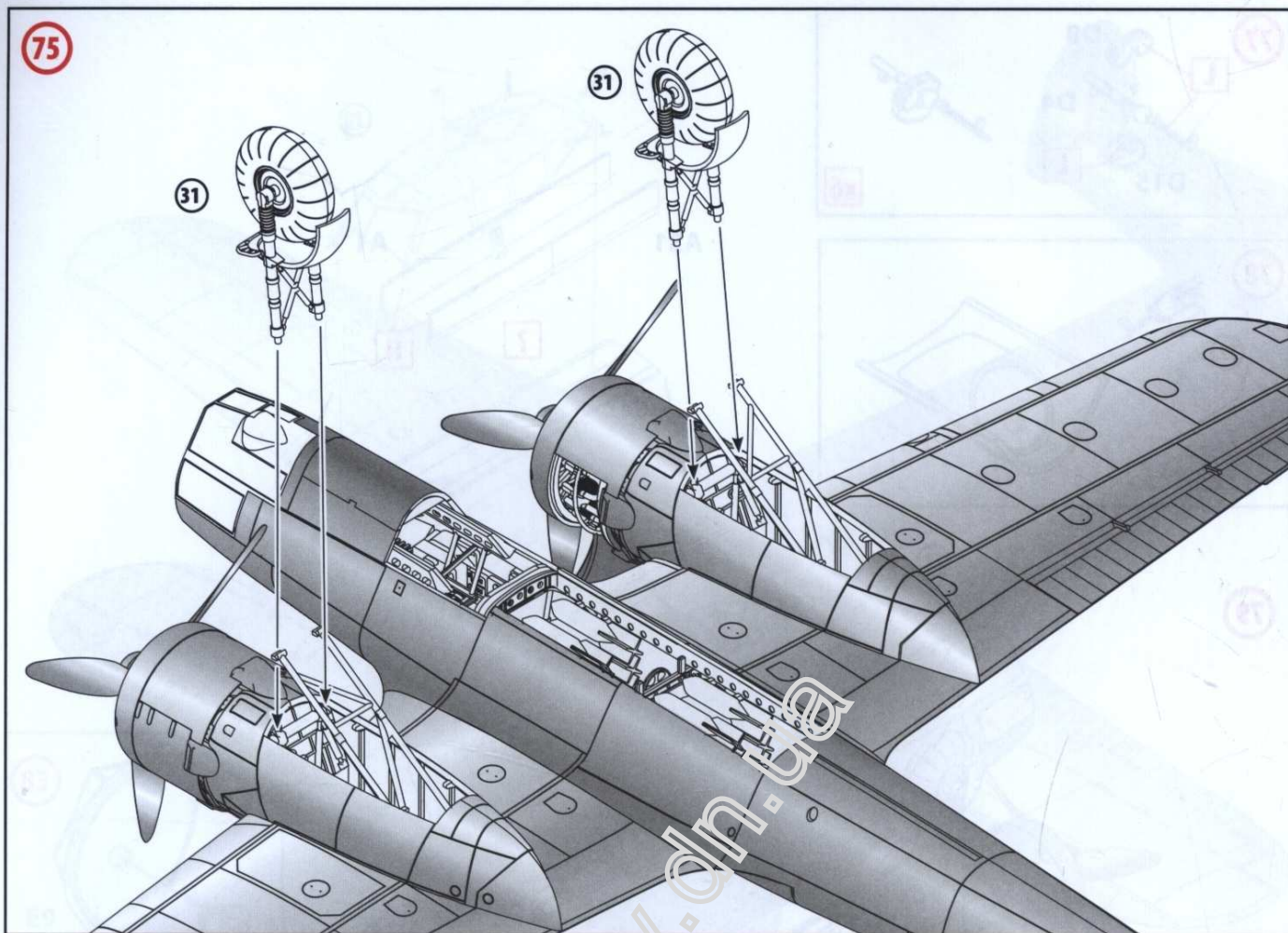

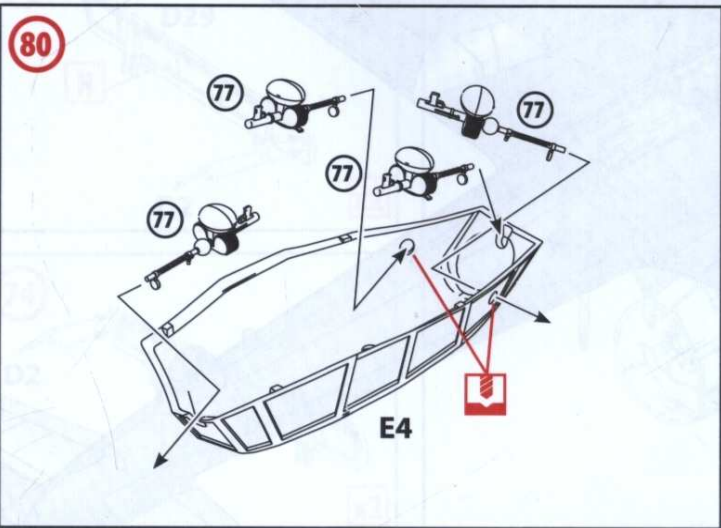
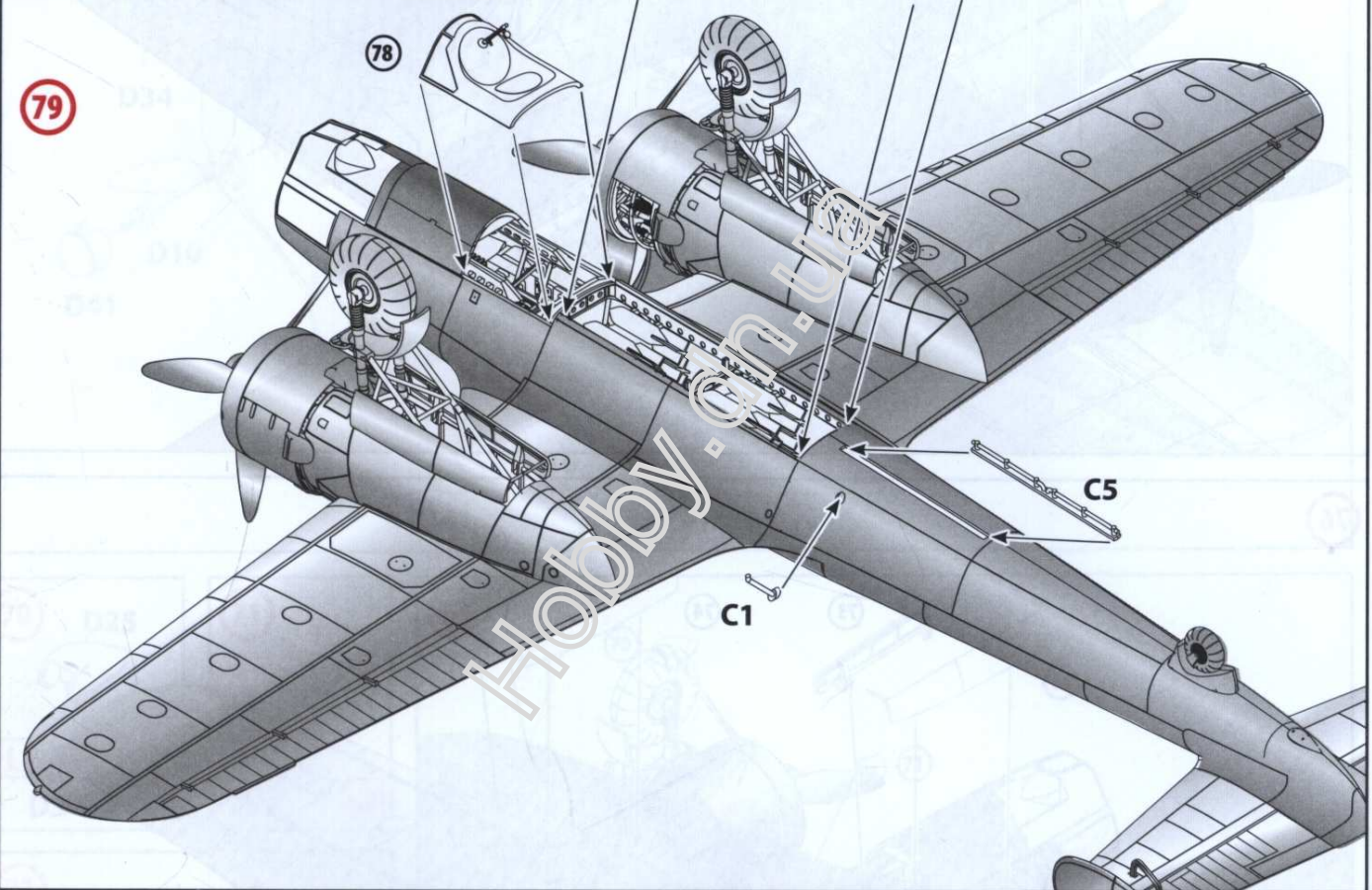
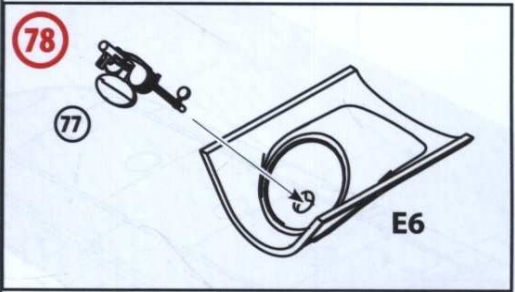
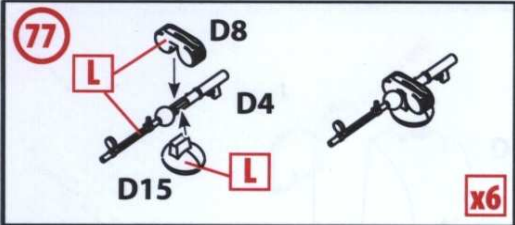

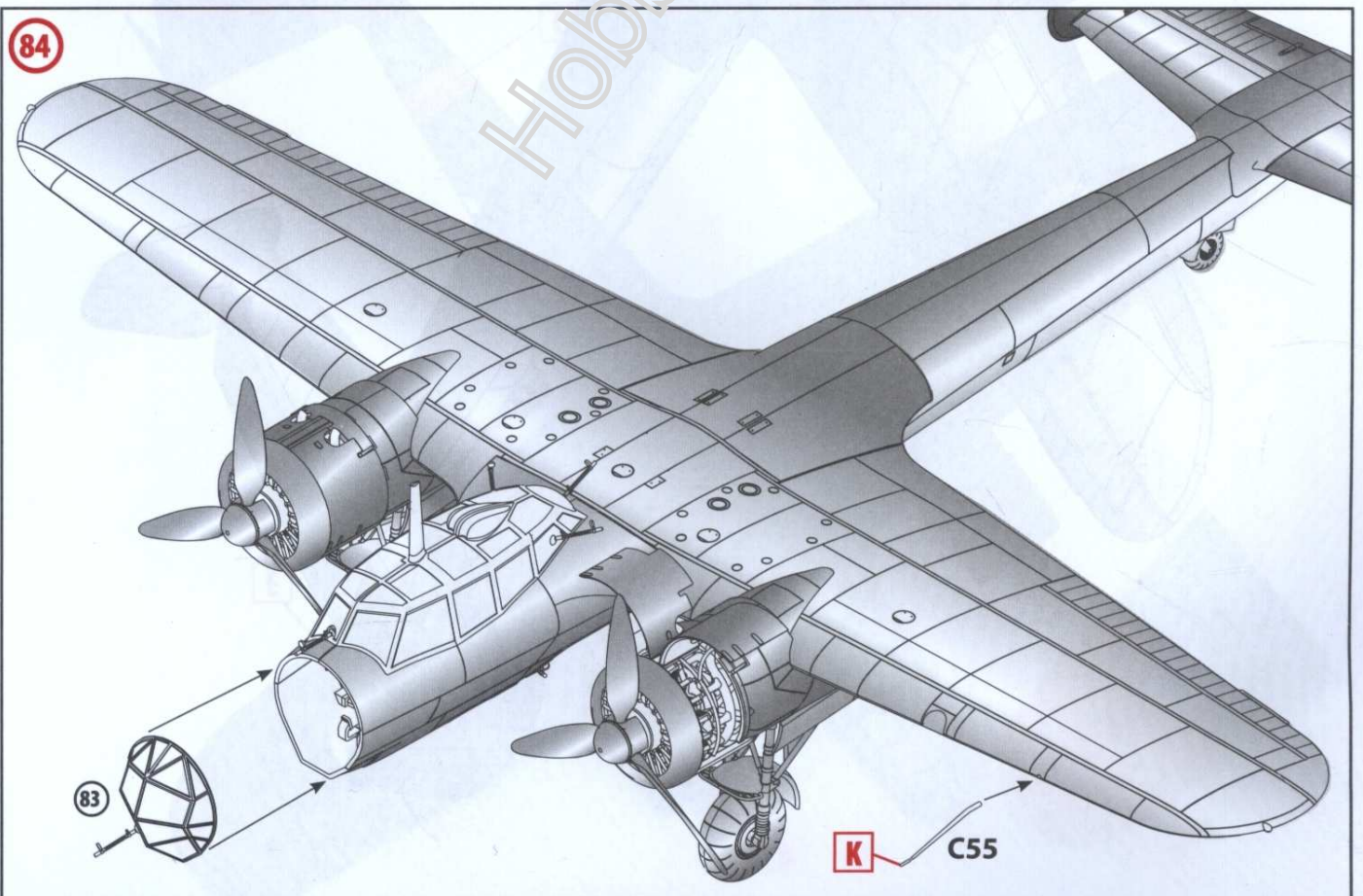
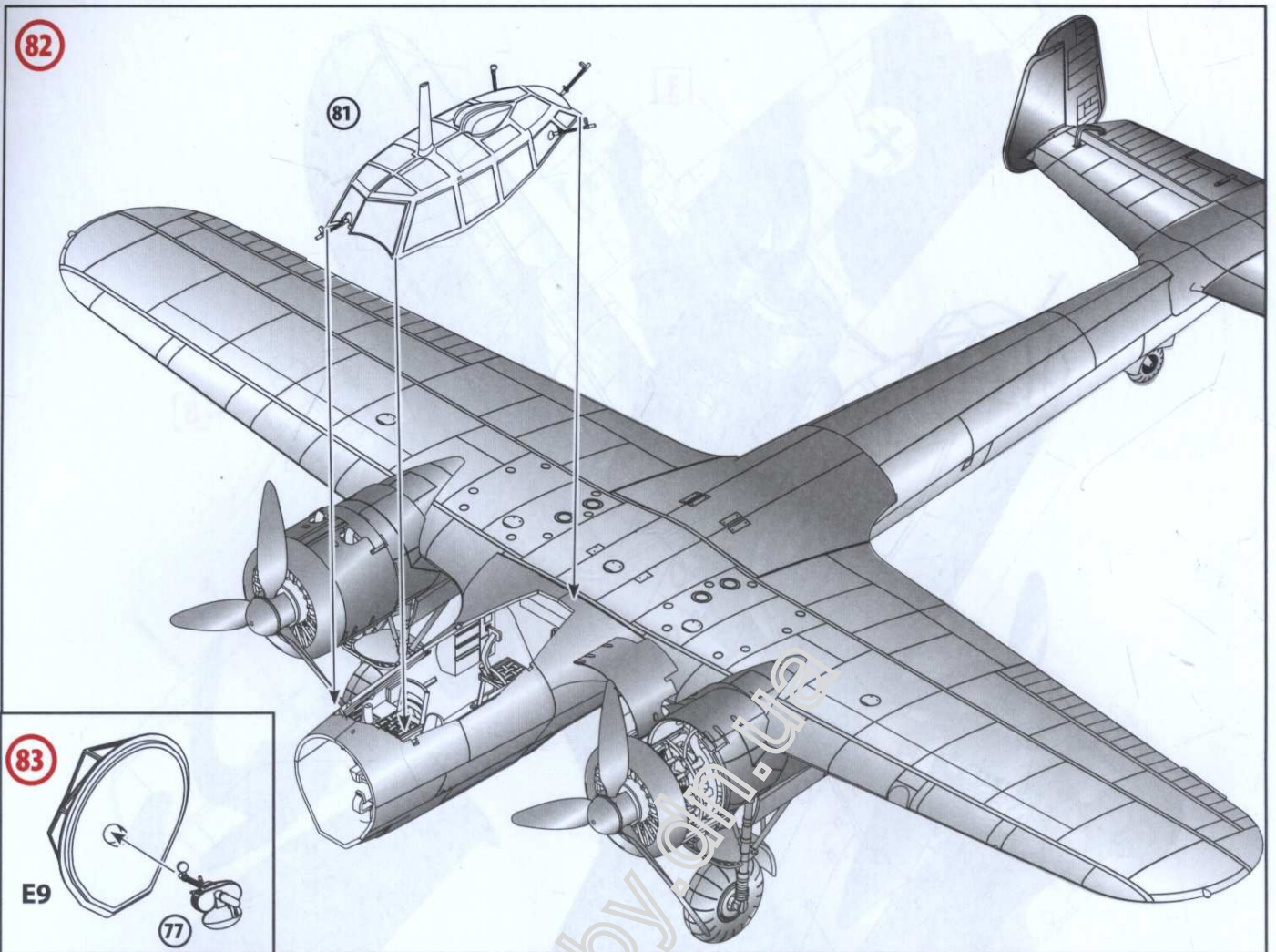

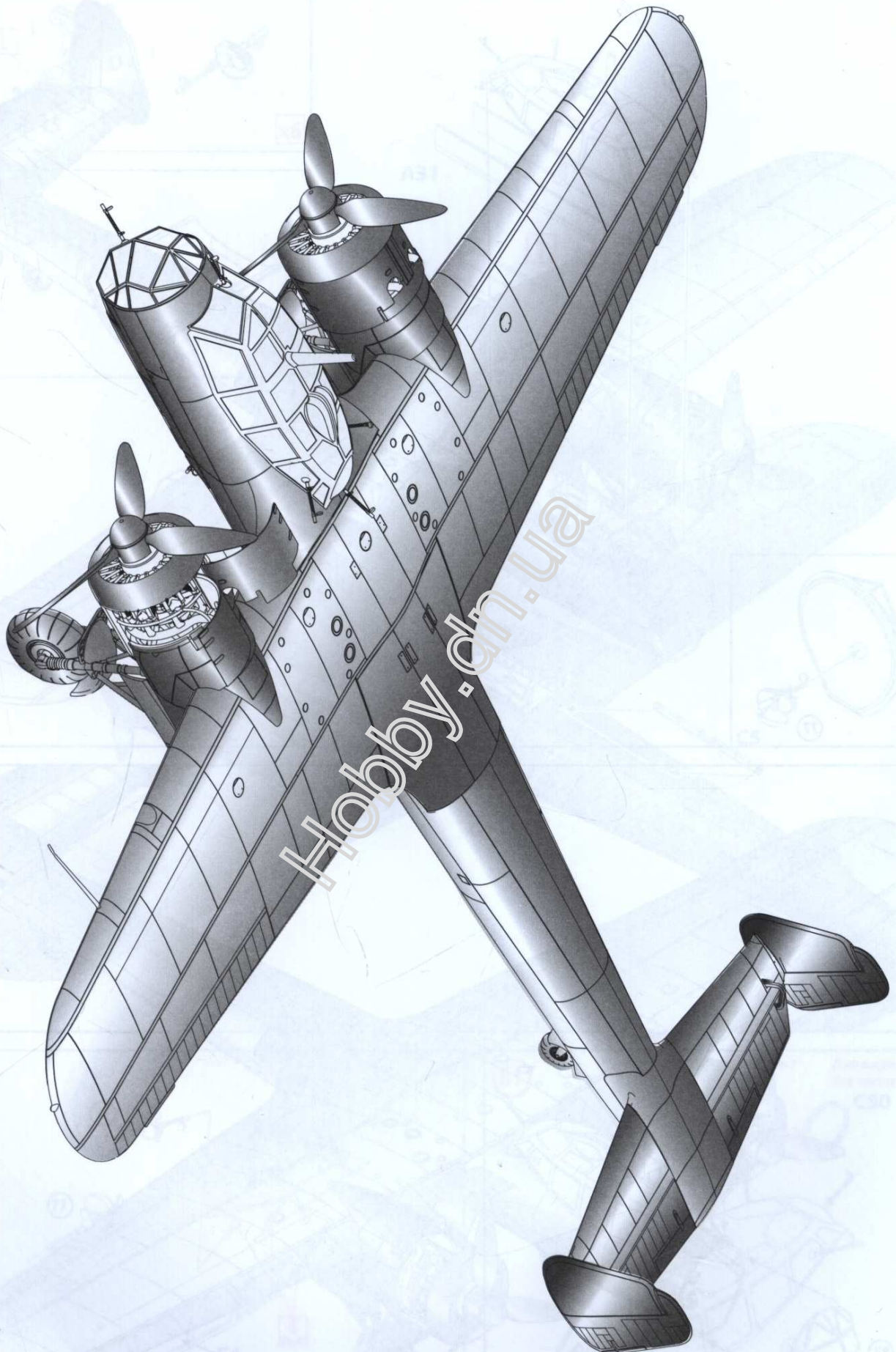

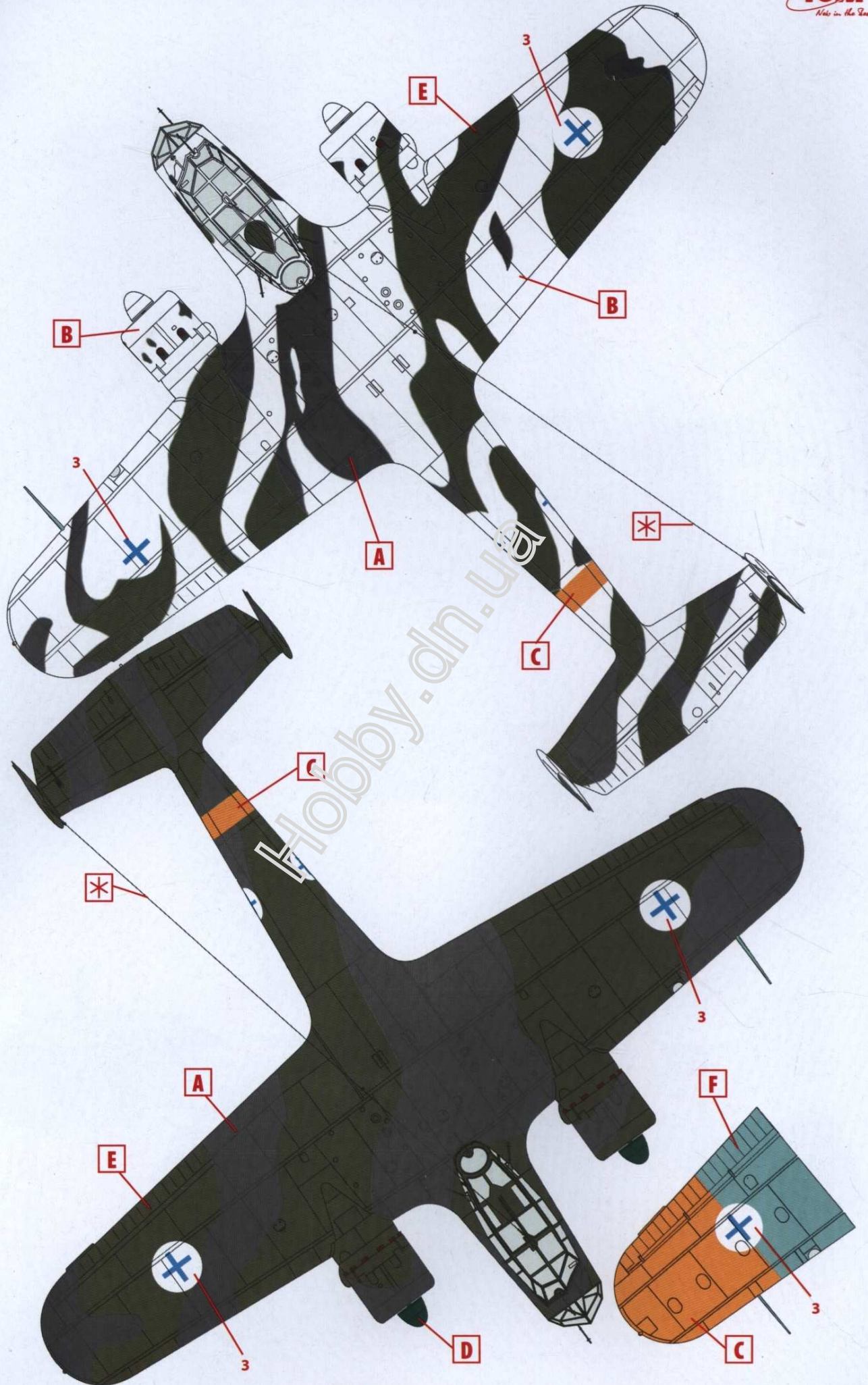

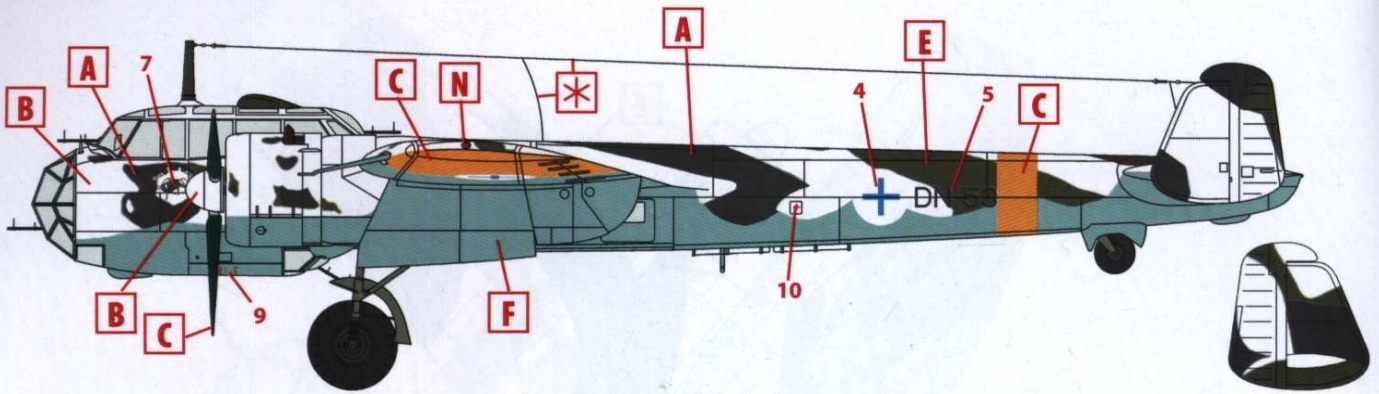

1. Do 17Z-2, 3/LeLv 46, BBC Финляндии, февраль 1942 г.
Do 17Z-2, 3/LeLv 46, Finnish Air Force, February 1942

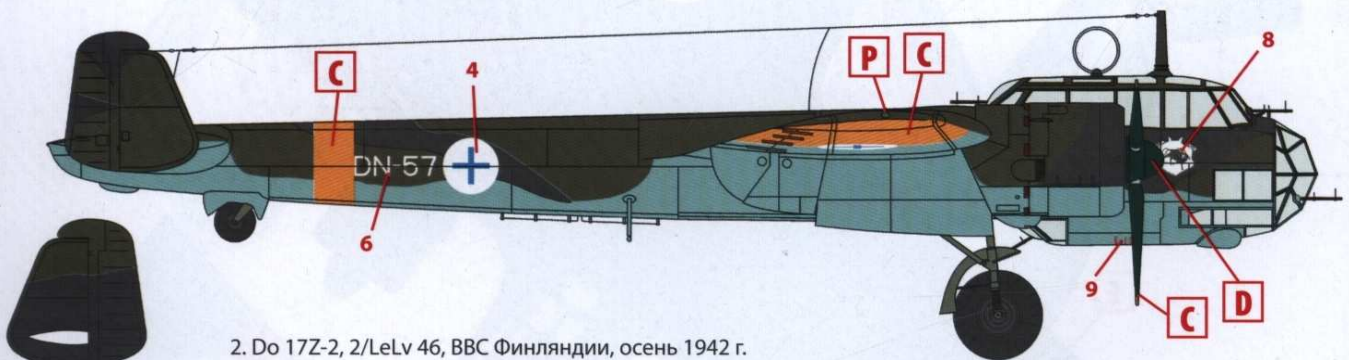
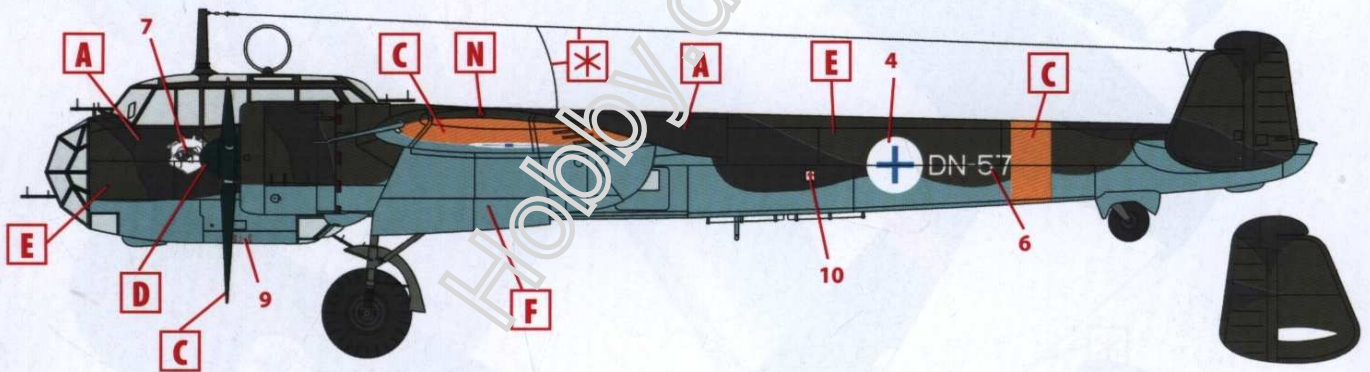

2. Do 17Z-2, 2/LeLv 46, BBC Финляндии, осень 1942 г.
Do 17Z-2, 2/LeLv 46, Finnish Air Force, Autumn 1942

ООО ICM Холдинг
ул. Бориспольская 9, строение 64,
02099, Киев, Украина
Тел./факс: +38(044) 369 54 12
E-mail: export@icm.com.ua



ICM Holding
Borispolskaya, 9, build. 64,
02099, Kiev, Ukraine
Tel./Fax: +38(044) 369 54 12
E-mail: export@icm.com.ua