



## He 111H-6 «Северная Африка» Германский бомбардировщик II ВВ

В начале 30-х годов в мире возникла идея создания скоростного бомбардировщика, который мог бы обогнать современные ему истребители-бипланы. Одним из воплощений этой концепции стал двухмоторный бомбардировщик He 111, разработанный германской фирмой Хейнкель Флюгzeugwerke.

С мая 1941 г. началось производство самолетов He 111H-6 с усиленным вооружением и двигателями жидкостного охлаждения Jumo 211F-2 увеличенной мощности с винтами VS 11, которые имели более широкие деревянные лопасти. Этот вариант мог нести бомбы SC 1800, либо – две торпеды LT F5b на внешней подвеске.

He 111H-6 был самым массовым вариантом среднего бомбардировщика Хейнкеля. До конца 1942 года было выпущено около 1800 самолетов. Они применялись на всех фронтах (включая – Северную Африку) как бомбардировщики, торпедоносцы, разведчики, транспортные самолеты и постановщики мин.

### Тактико-технические характеристики He 111H-6

Длина, м	16,38
Размах крыла, м	22,50
Взлетный вес, кг	14000
Двигатель	2xJumo 211F-2, 1340 л.с.
Максимальная скорость, км/ч	435
Потолок, м	6700
Дальность, км	1950
Вооружение	1 2x20 мм пушки, MG FF, 4-7x7,92-мм пулеметов MG 15, до 2000 кг бомб, либо – 2 торпеды LT F5b

### ВНИМАНИЕ!

Перед сборкой внимательно прочитайте руководство по монтажу. Каждая деталь пронумерована. Соблюдать последовательность монтажа. Необходимые рабочие инструменты: нож и напильник для зачистки деталей; резиновая лента, клейкая лента и зажимы для сушки белья для прижимания склеиваемых деталей. Детали из пластика очистить в растворе мягкого моющего средства и высушить на воздухе для того, чтобы краска и передельные кляксы лучше прилипали. Перед приклеиванием проверить, подходят ли детали: клей не носить эконо. Хром и краску удалить с поверхности склеивания. Небольшие детали покрасить перед тем, как они будут удалены из рамок. Краску необходимо хорошо просушить, только после этого продолжить сборку. Каждую соответствующую переводную картинку отдельно вырезать, примерно на 20 секунд окунуть в теплую воду. На обозначенном месте картинку отделить от бумаги и прижать промокательной бумагой.

### ИСПОЛЬЗУЕМЫЕ КРАСКИ / USED COLORS:

	Revell	Tamiya		
<b>A</b>	108	XF1	Черный, матовый	Flat Black
<b>B</b>	105	XF2	Белый, матовый	Flat White
<b>C</b>	117	XF59	Темно-песочный RLM79	Africa Brown RLM79
<b>D</b>	140	XF27	Черно-зеленый RLM 70	Schwarzgrun RLM70
<b>E</b>	139	XF61	Темно-зеленый RLM80	Dunkelgrun RLM80
<b>F</b>	149	XF23	Голубой RLM78	Hellblau RLM78
<b>G</b>	177	XF84	Черно-серый, матовый	Schwarzgrau RLM66
<b>H</b>	145	XF22	Серо-зеленый RLM02	Grau RLM02

## He 111H-6 North Africa WWII German Bomber

In the beginning of 30s it was appeared in the world an idea of high-speed bomber that could outstrip contemporary fighters. One of the objectifications of this conception became the twin-engine bomber He 111 designed by a German Heinkel Flugzeugwerke AG company.

Since the May of 1941 it were produced He 111H-6 planes with liquid-cooled Jumo 211F-2 engines of increased power, with VS 11 wooden wider horde propellers and more powerful armament. This variant could carry SC 1800 kg bombs or two LT F5b torpedoes externally.

The He 111H-6 was the most produced variant of Heinkel's medium bomber. It were produced approximately 1800 aircraft up to the end of 1942. He 111H-6s saw service on all fronts (including North Africa) as level bombers, torpedo bombers, reconnaissance aircraft, transports, and mine layers.

### Tactical and Technical Specifications of He 111H-6

Length, m	16,38
Span, m	22,50
Start weight, kg	14000
Engines	2xJumo 211F-2, 1340 hp
Max. Speed, km/h	435
Service ceiling, m	6700
Range, km	1950
Armament	1-2x20 mm MG FF, 4-7x7,92 mm MG 15, bomb load - up to 2000 kg or 2 LT F5b torpedoes

### CAUTION!

Read the instructions thoroughly prior to assembly. Each component is numbered. Adhere to specified sequence of assembly. Tools required: knife and file for removal of components from frame; rubber bond, adhesive tape and clothes pegs for clamping components together after applying adhesive. Clean plastic components in a mild detergent solution and allow to air-dry so that paint and transfers adhere better. Prior to applying adhesive, check to see whether the components fit together; apply adhesive sparingly. Remove chrome and paint from the contact surfaces. Paint small components before removing them from the frame. Allow paint to dry well, and only then continue to assemble. Cut out each transfer individually and immerse in warm water for approx. 20 seconds. Slide transfer off paper and into designated position, then press on with blotting paper.

**01** СТАДИЯ СБОРКИ  
ASSEMBLY STEP

**03** СБОРОЧНАЯ ЕДИНИЦА  
ASSEMBLY UNIT

**A** ИСПОЛЬЗУЕМАЯ КРАСКА  
USED COLOR

ОТРЕЗАТЬ  
CUT OFF

НЕ КЛЕИТЬ  
DO NOT CEMENT

ПРИ СБОРКЕ НЕ ИСПОЛЬЗУЕТСЯ  
PARTS NOT FOR USE

**x2** СДЕЛАТЬ ДВЕ ДЕТАЛИ  
MAKE 2 PCS

СДЕЛАТЬ САМОМУ  
SCRATCH BUILD

**?** ПРОИЗВОЛЬНЫЙ ВЫБОР  
OPTIONAL

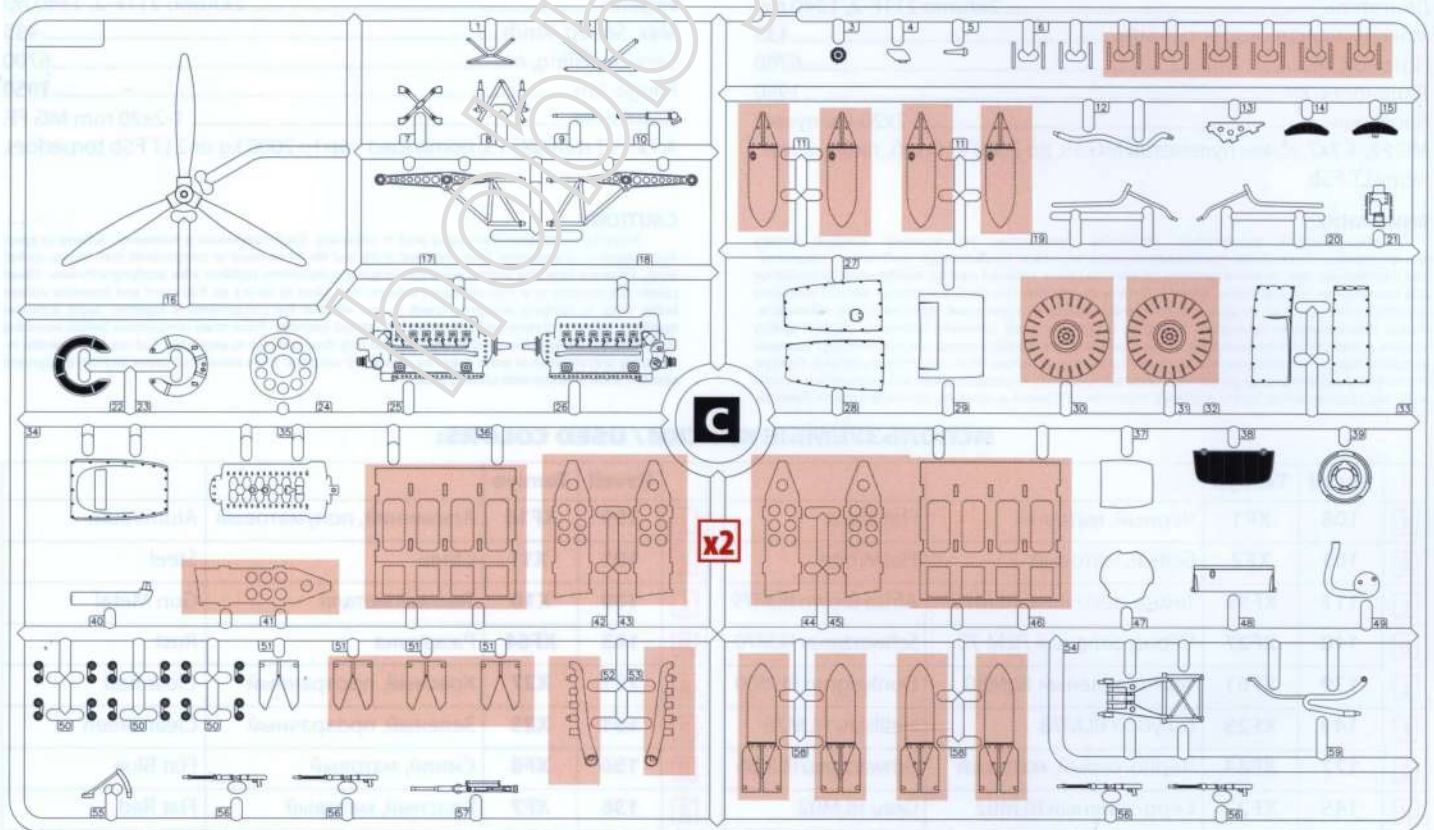
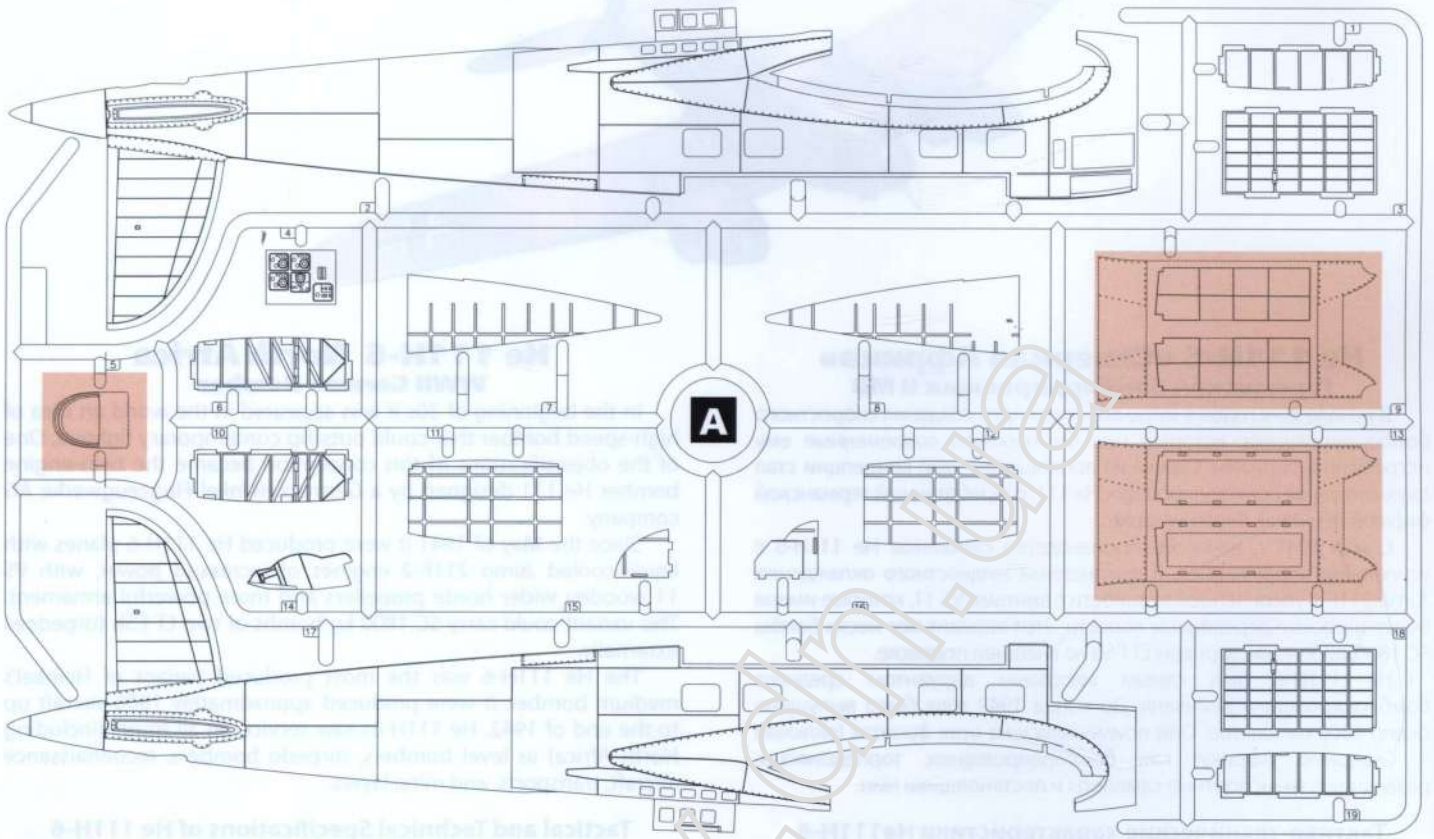

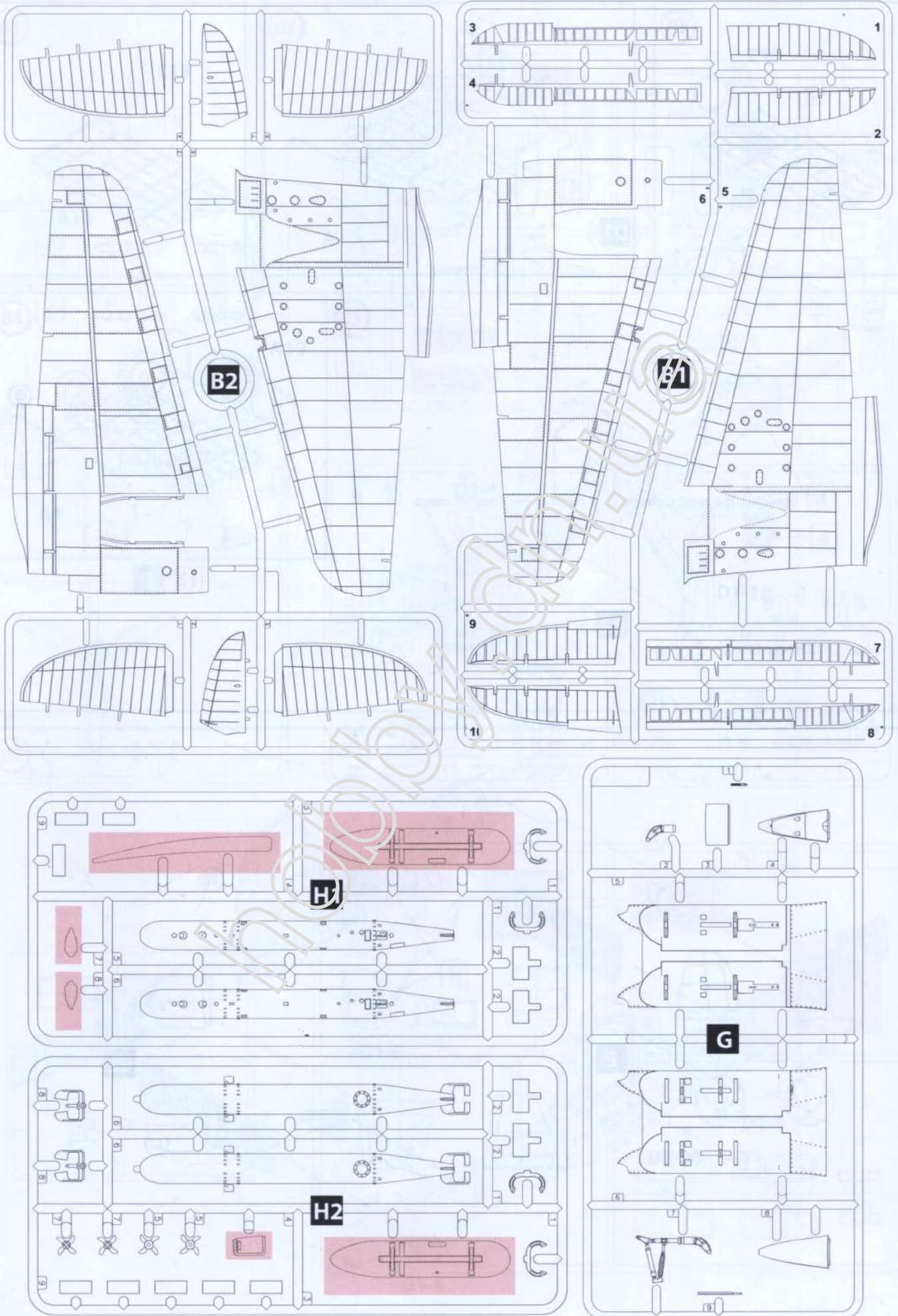

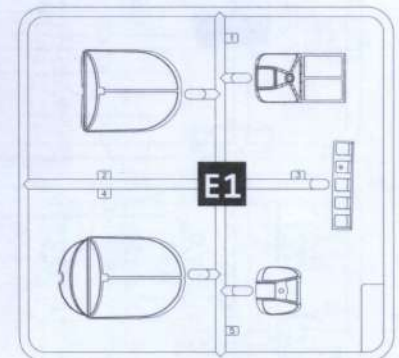
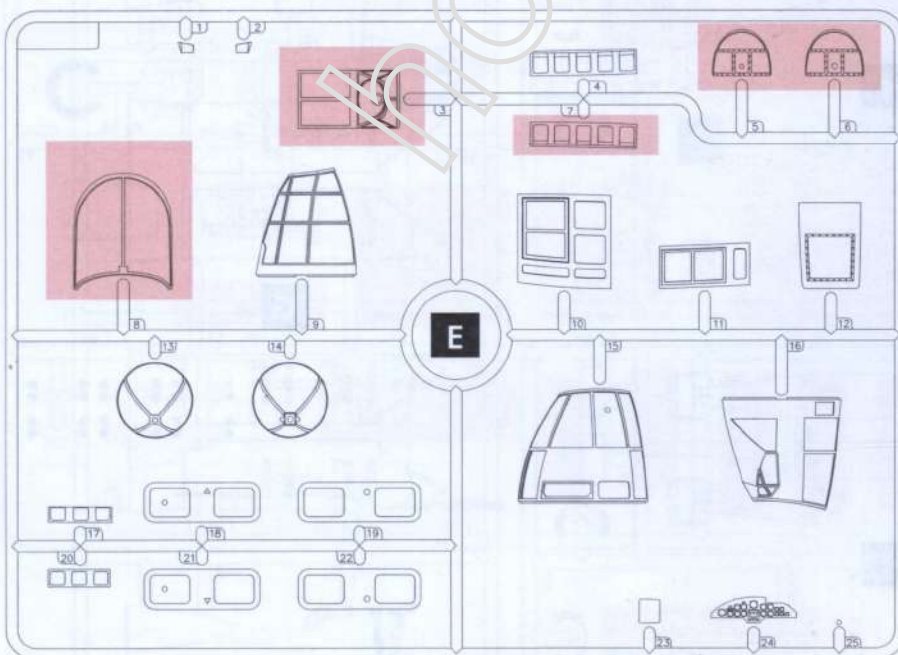
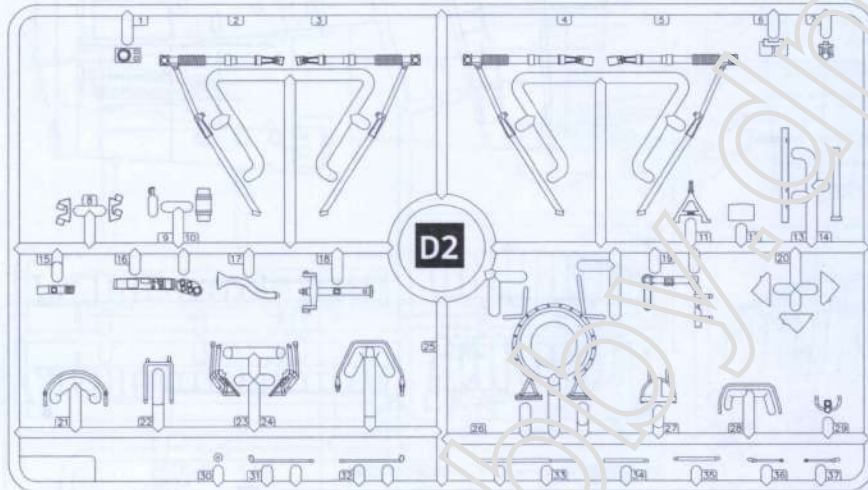
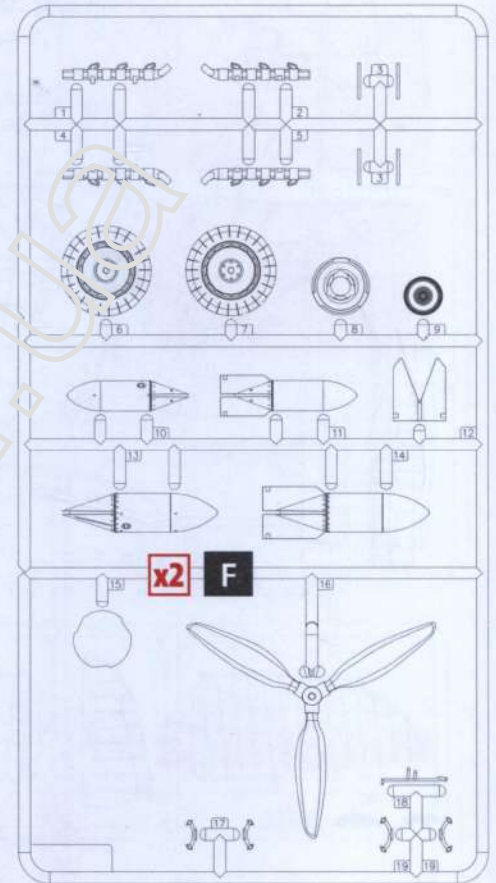
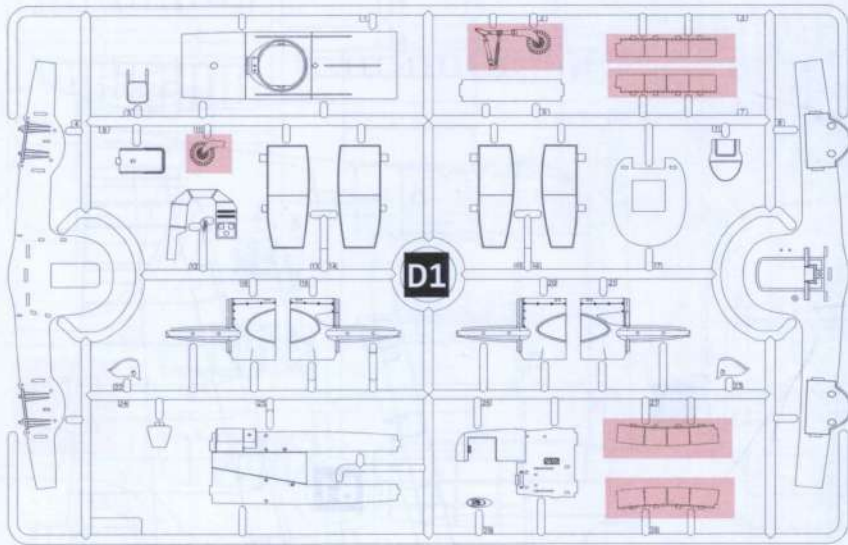

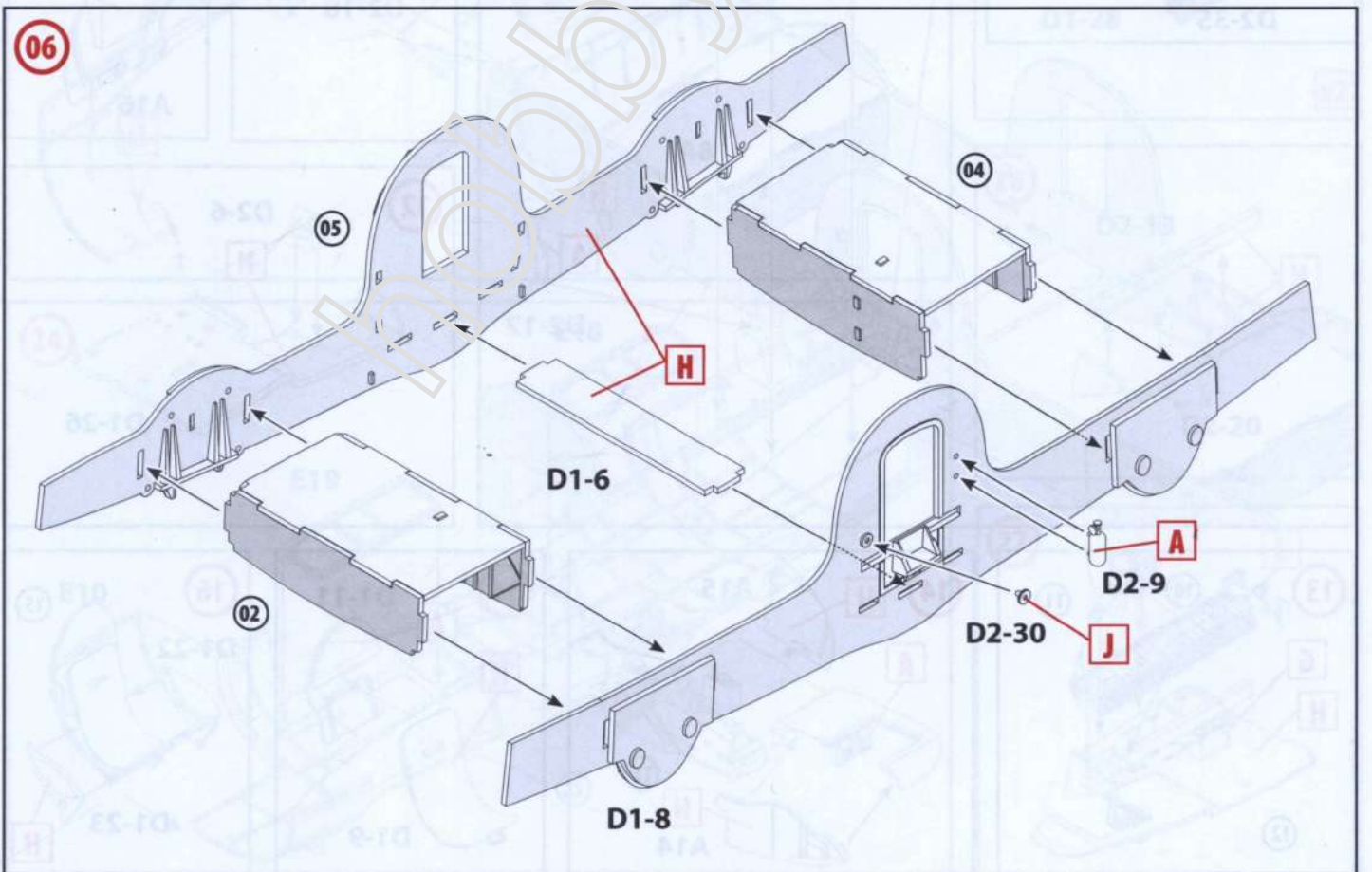
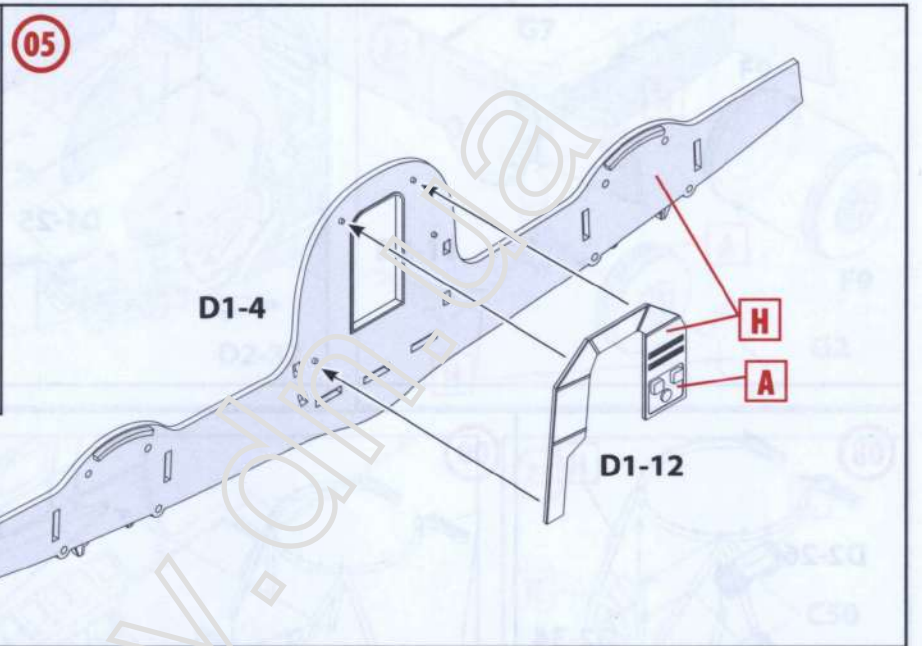
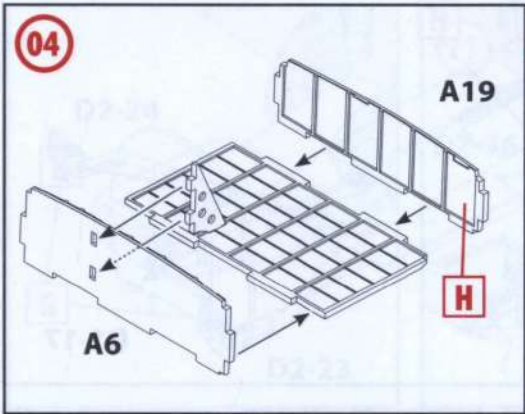
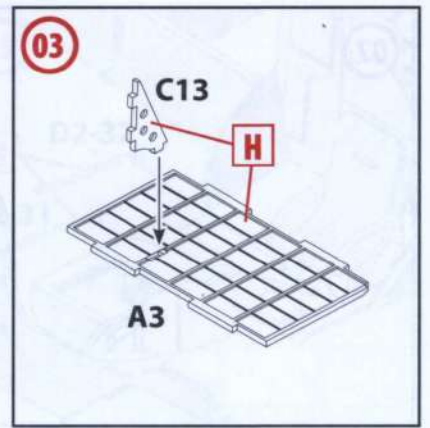
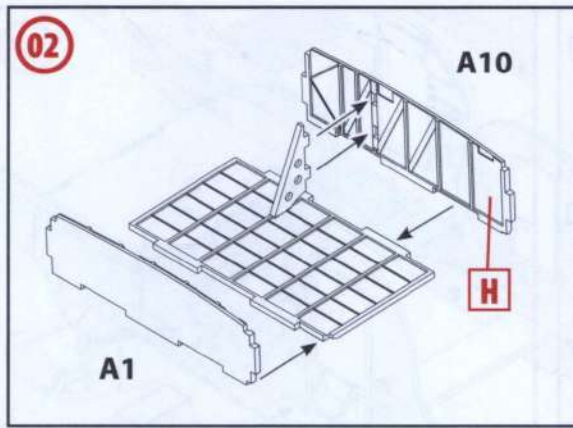
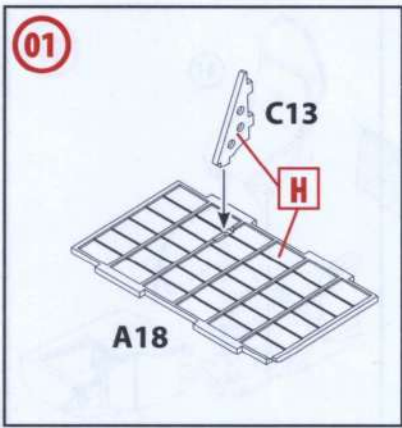

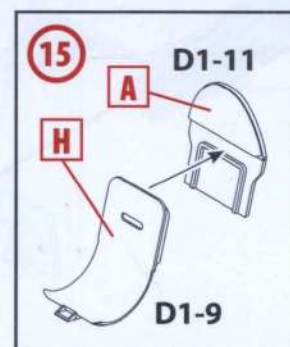
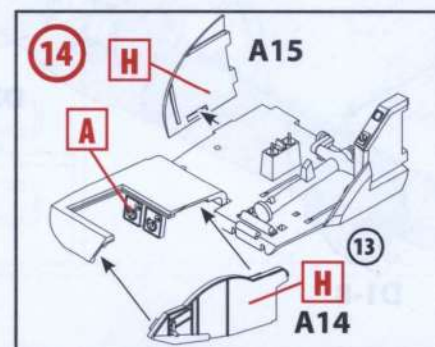
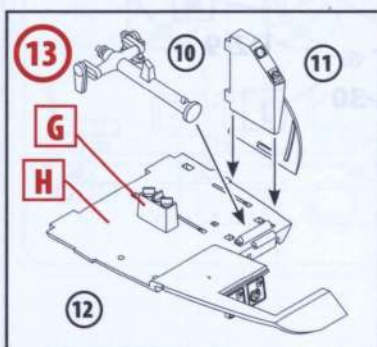
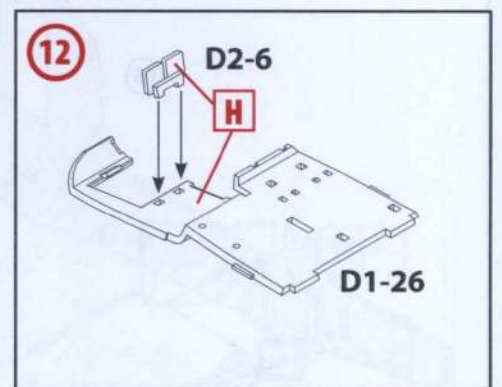
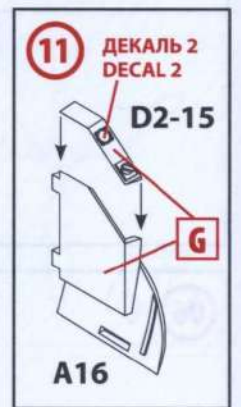
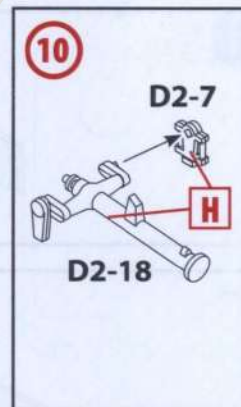
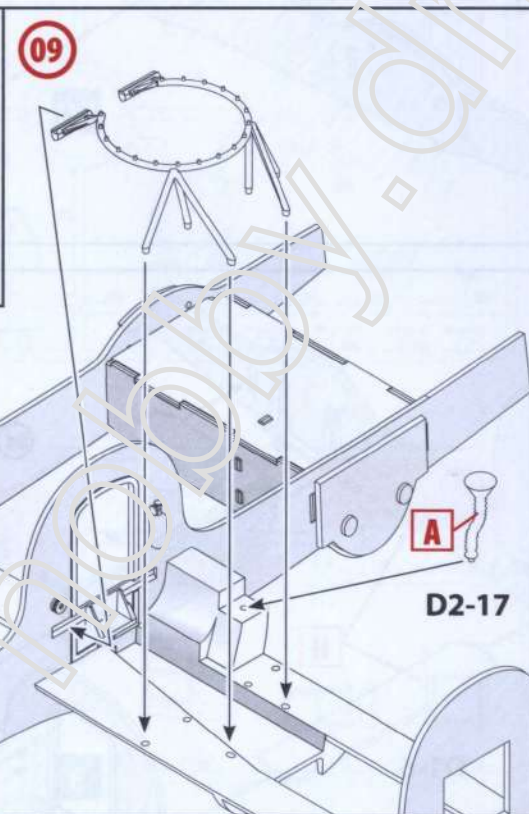
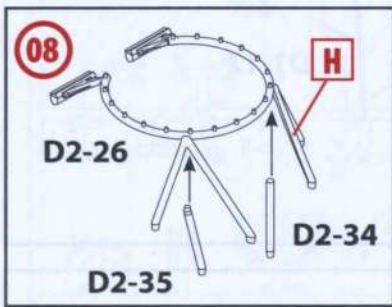
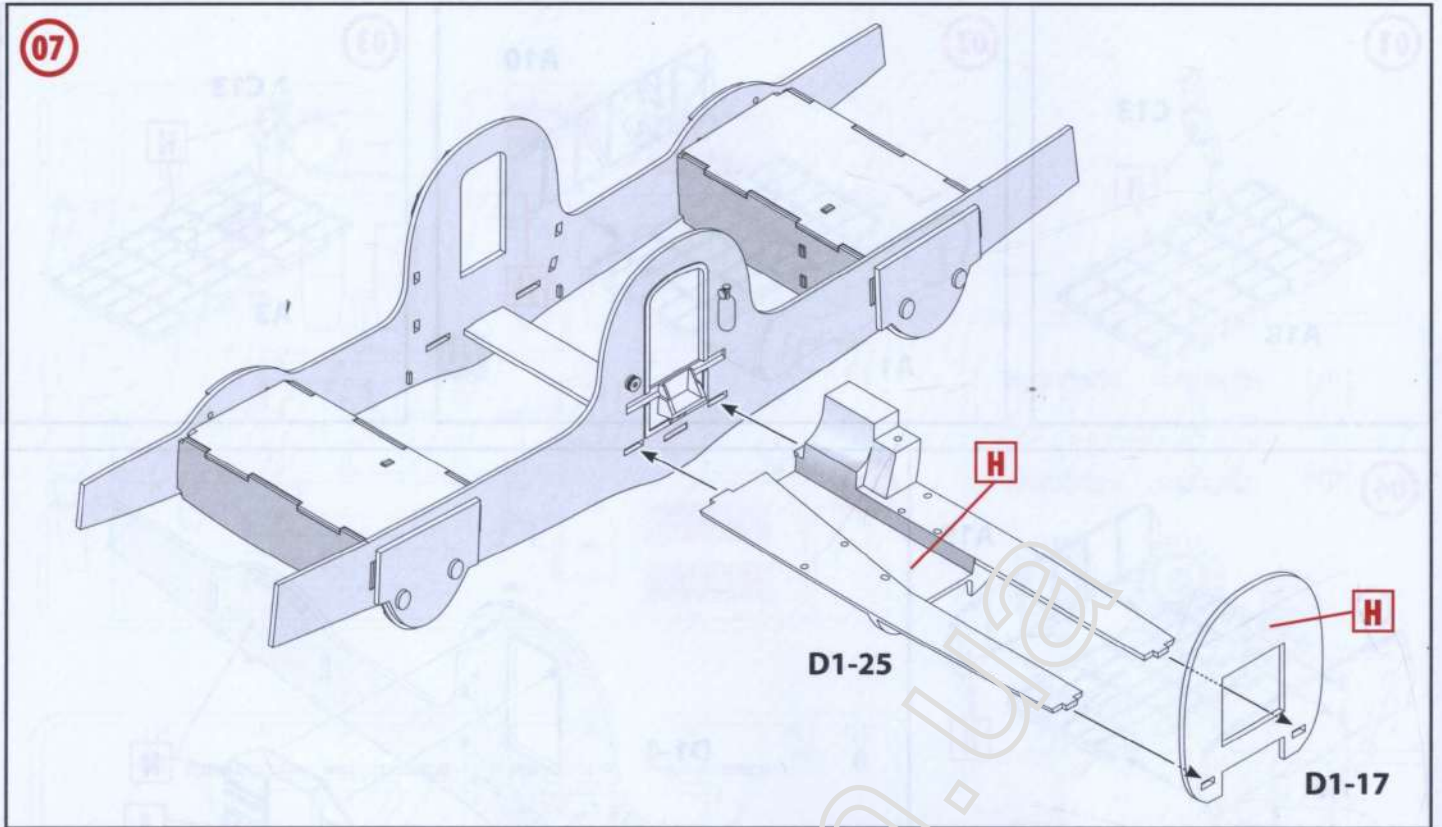

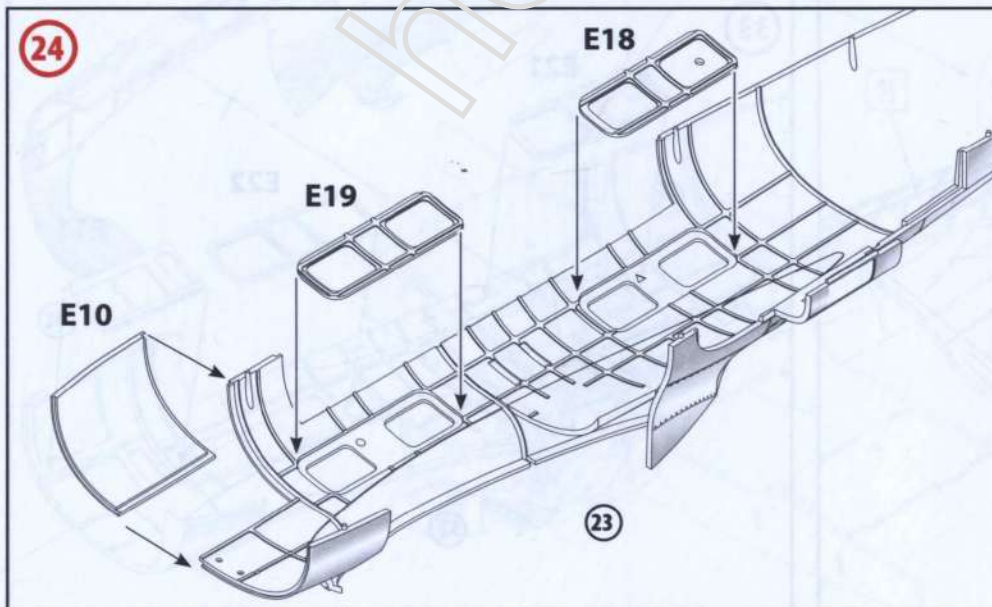
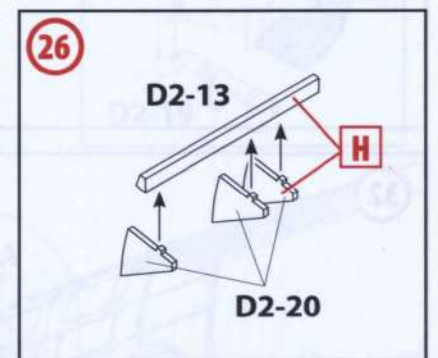
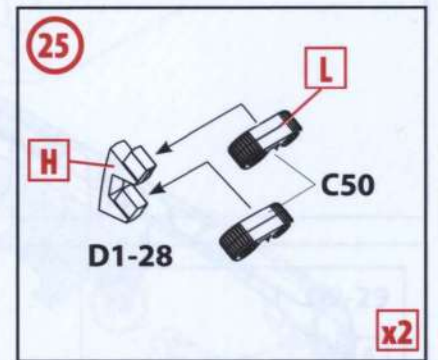
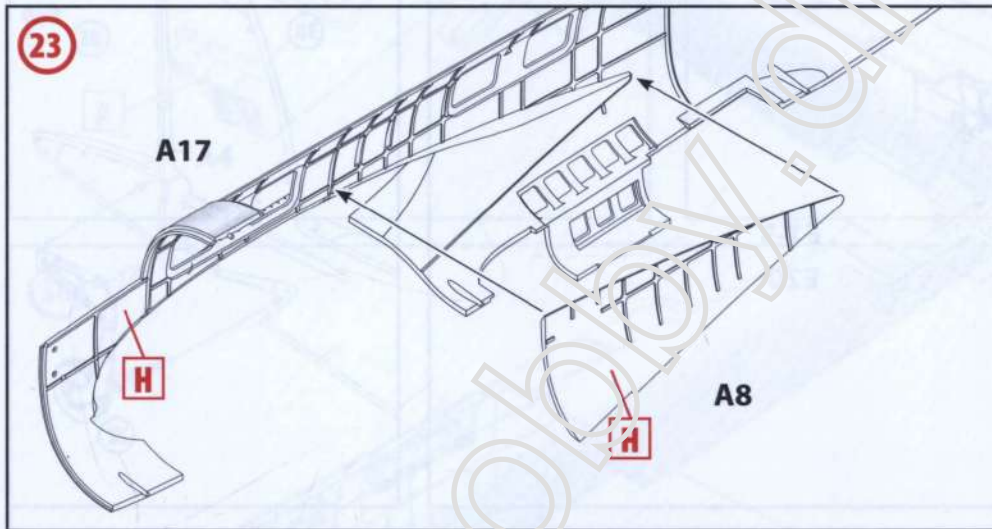
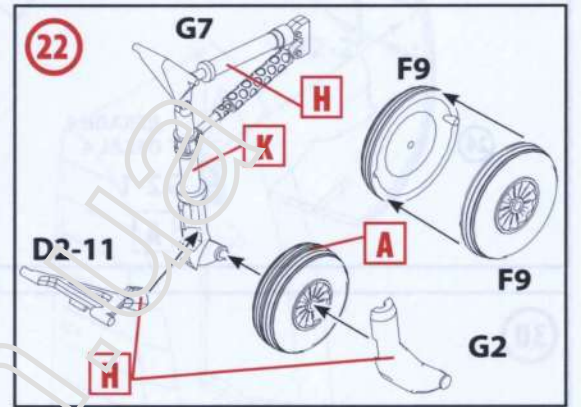
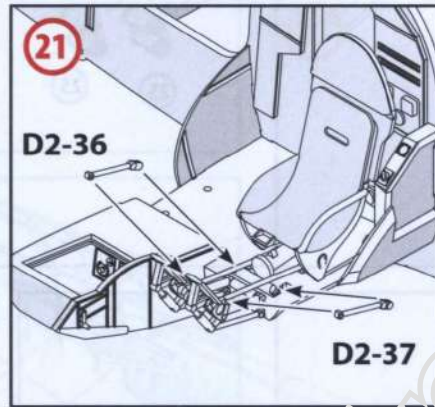
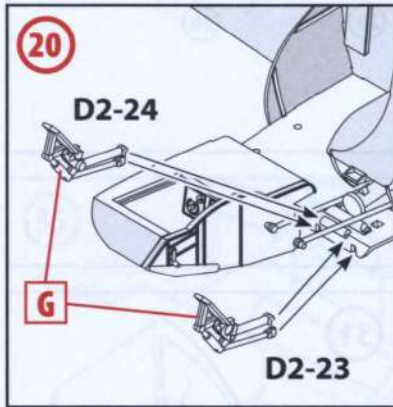
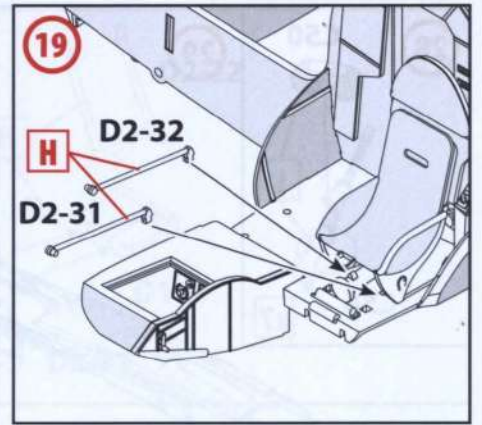
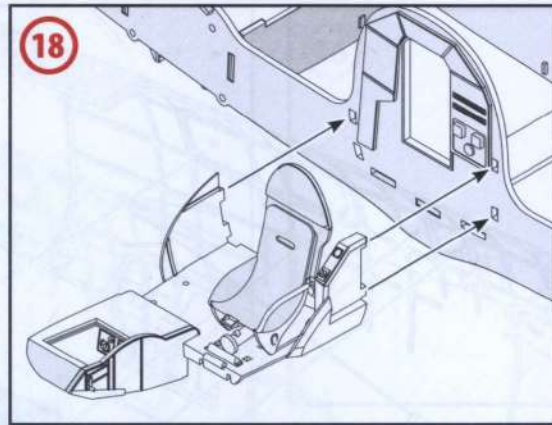

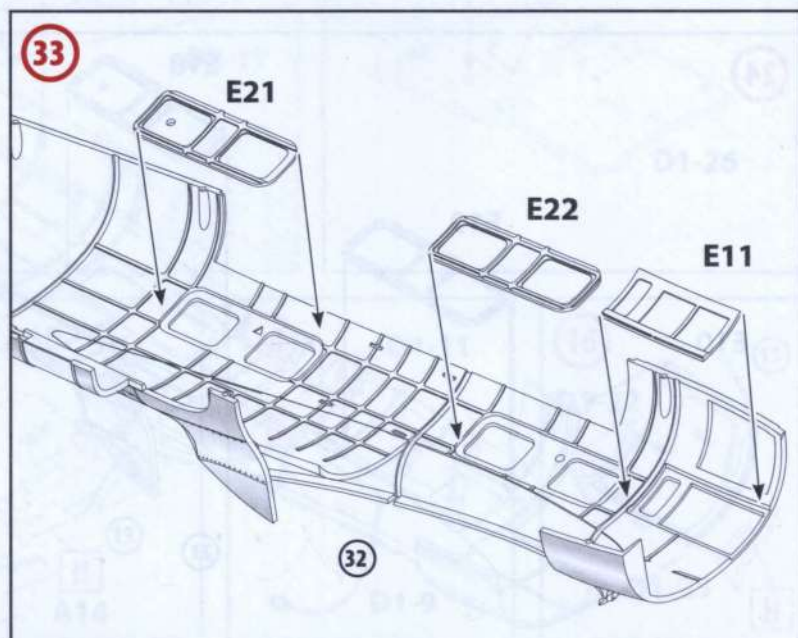
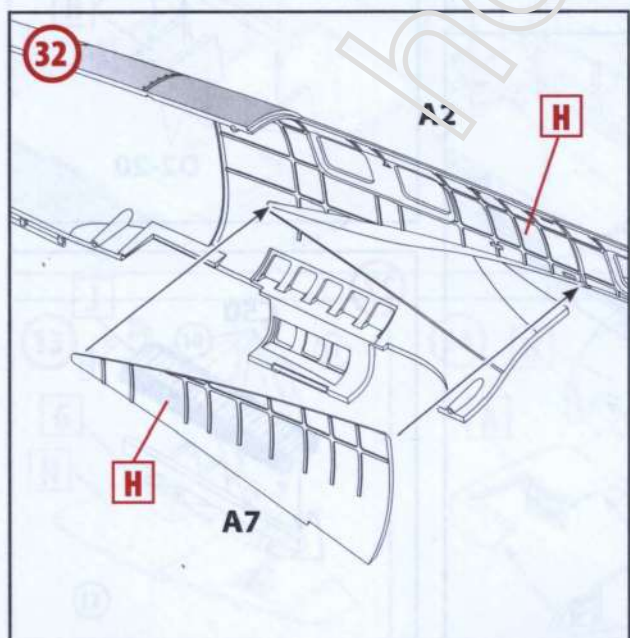
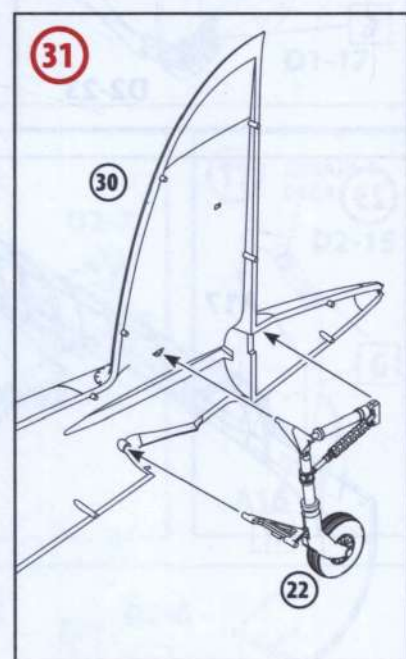
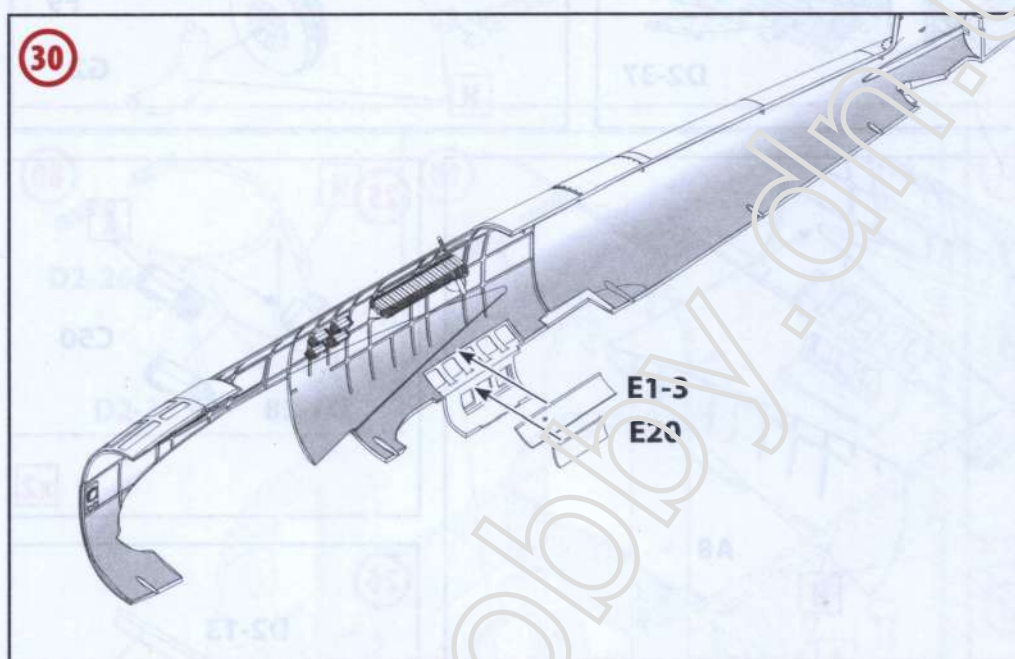
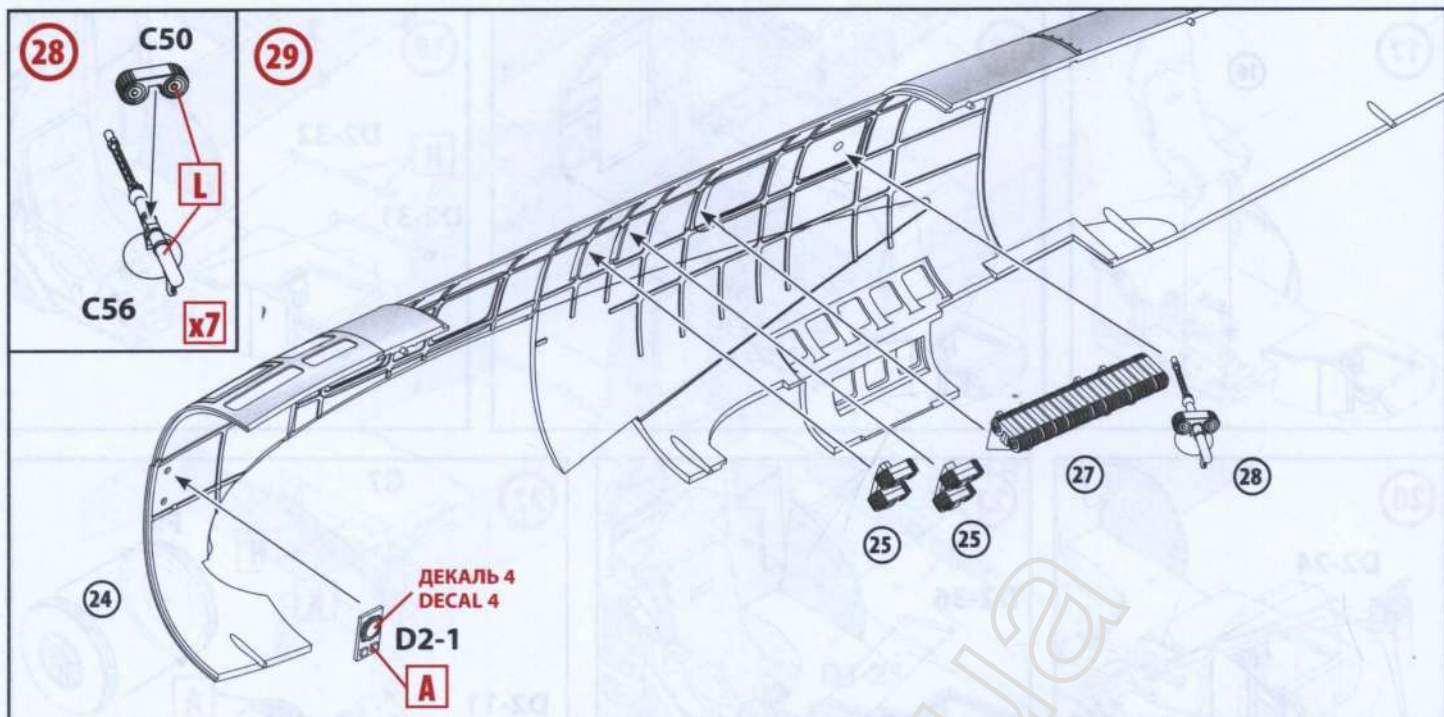



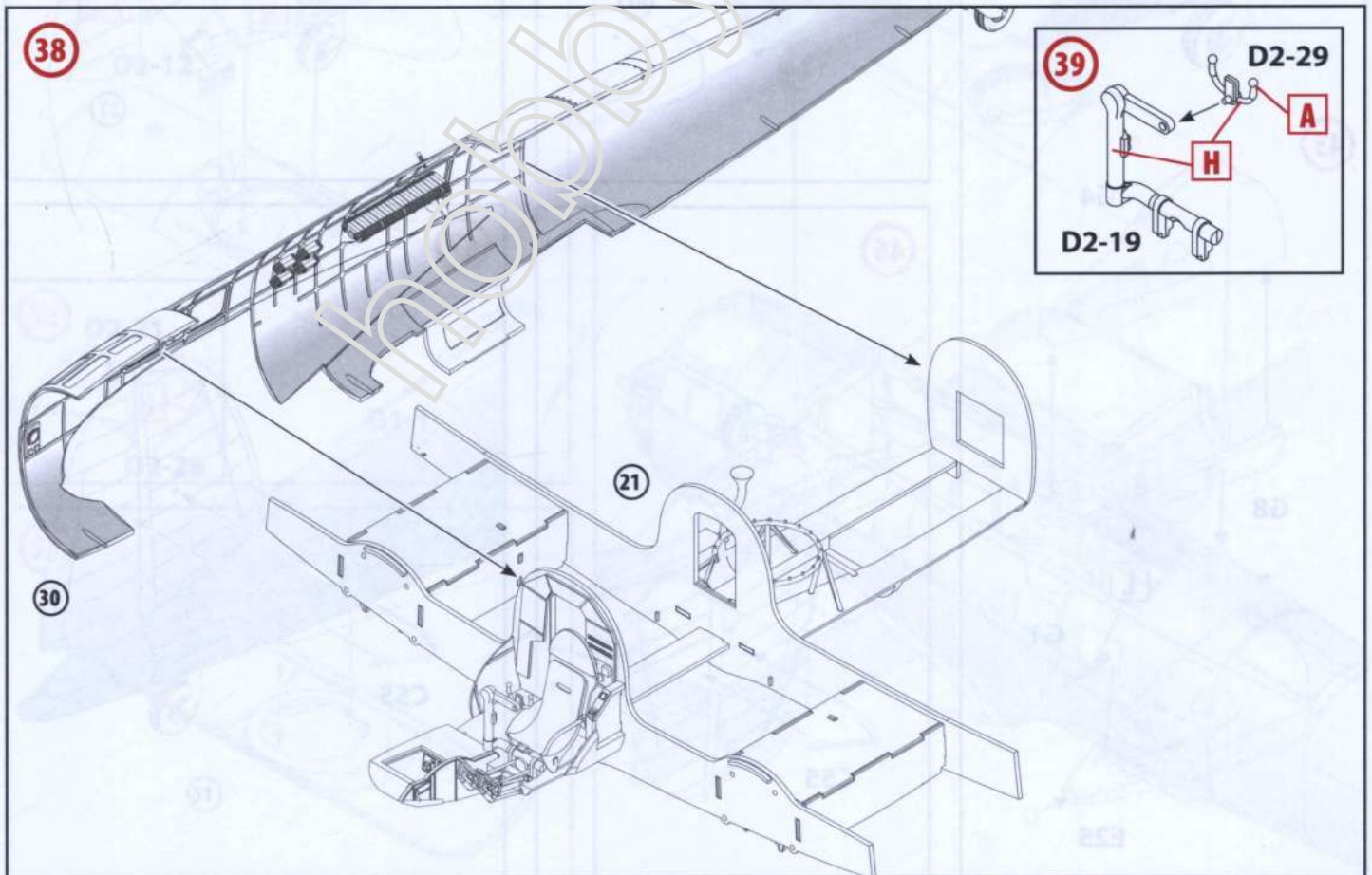
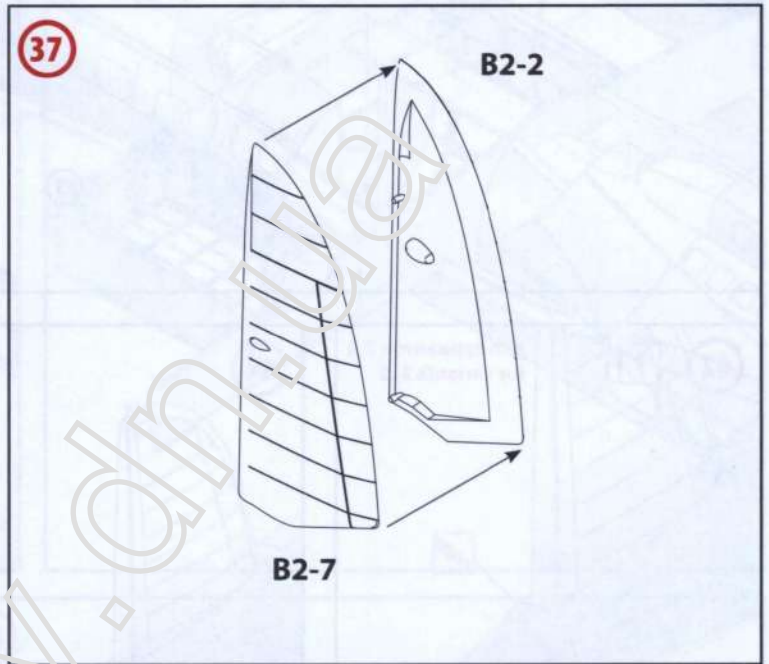
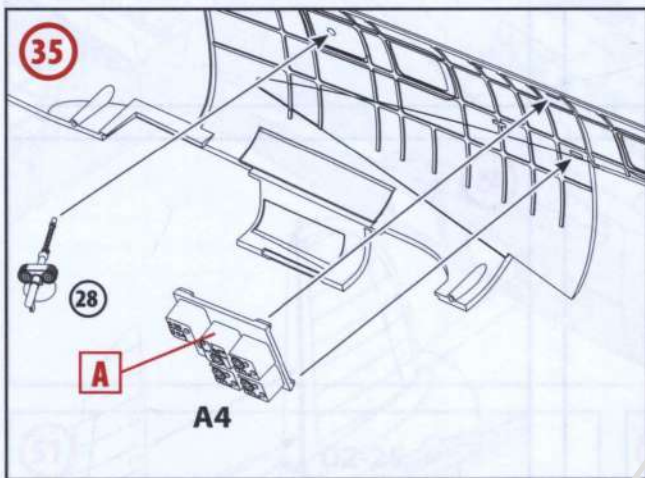
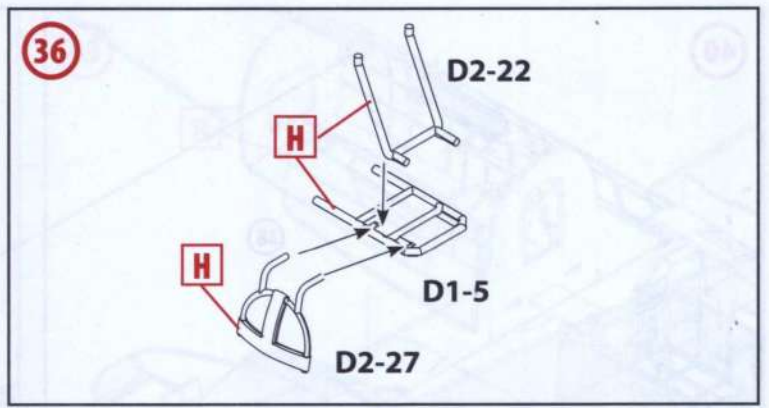
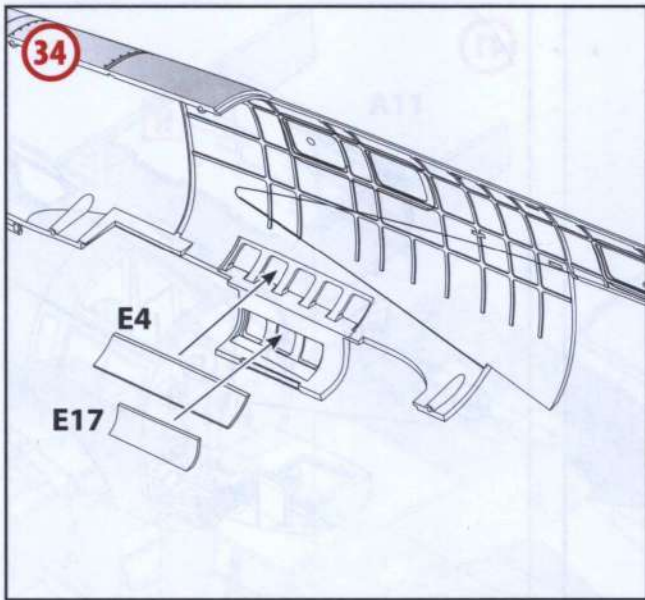

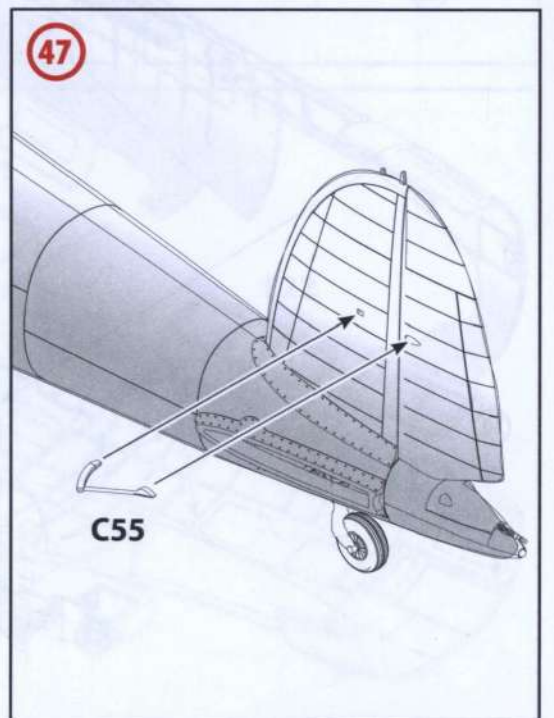
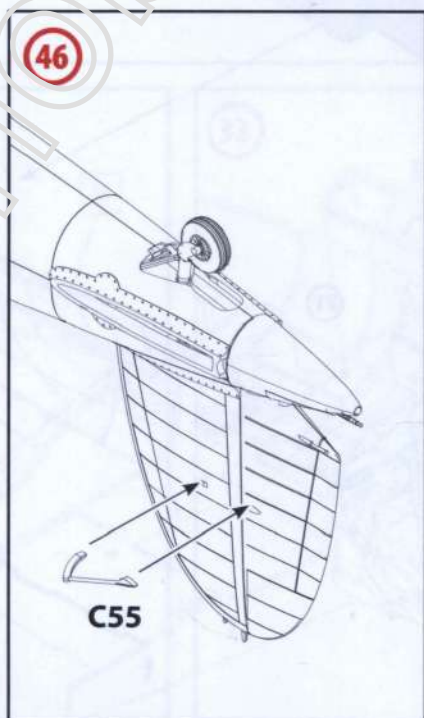
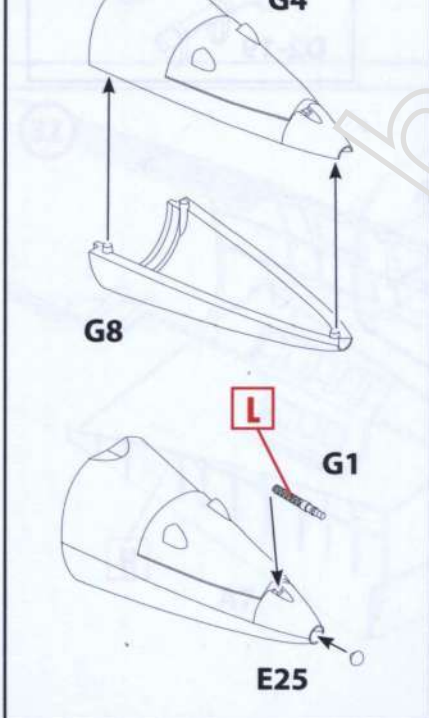
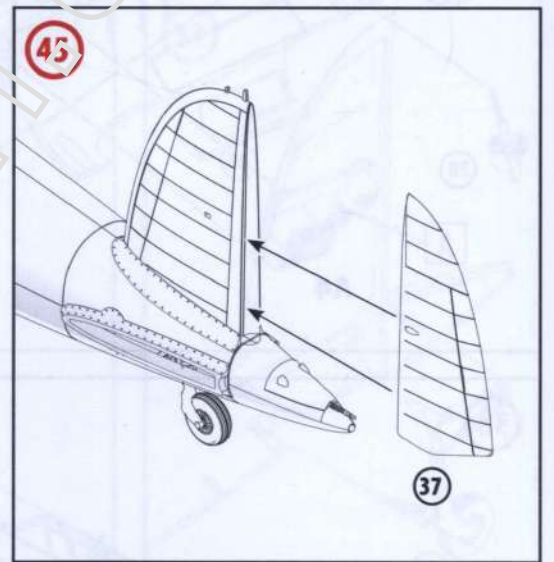
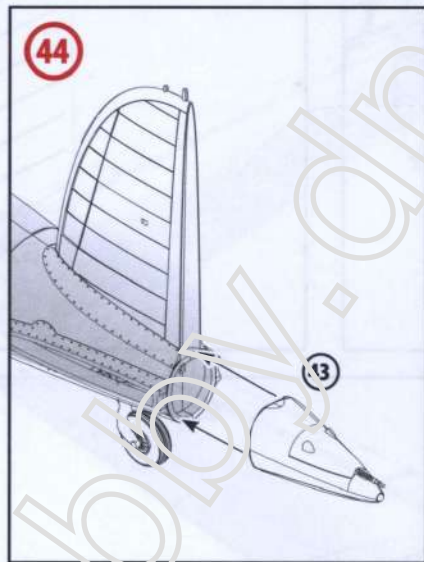
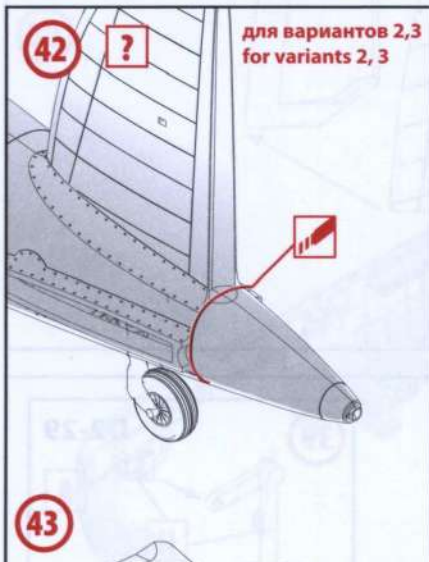
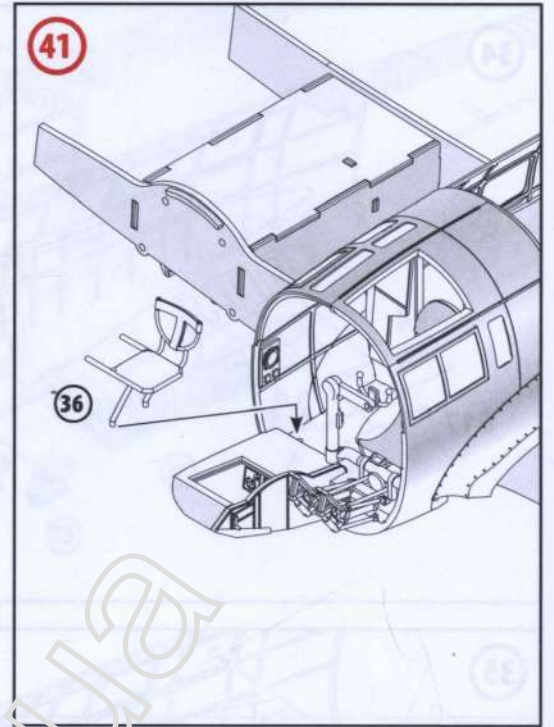
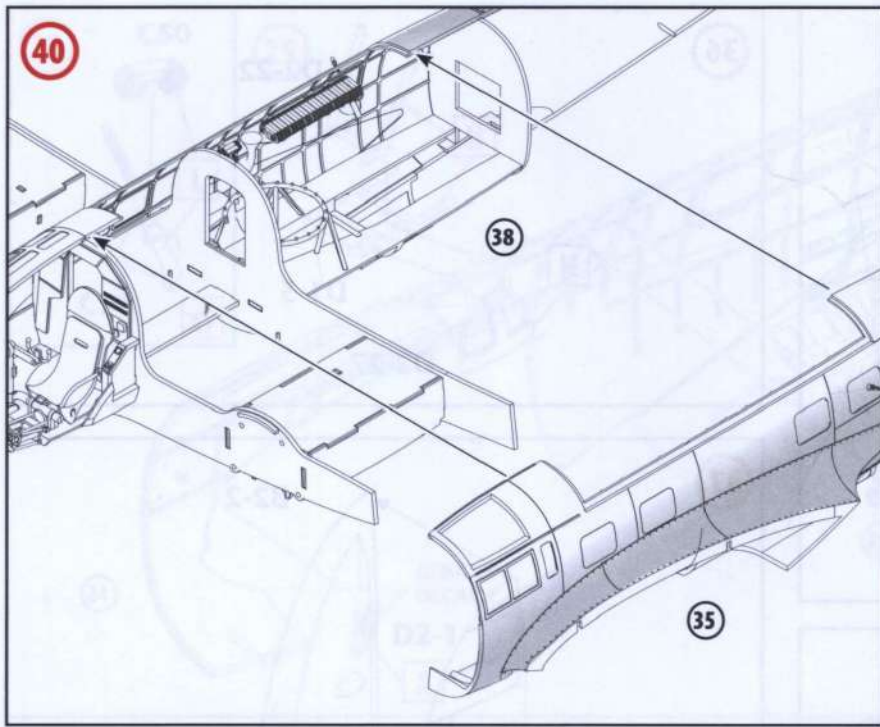

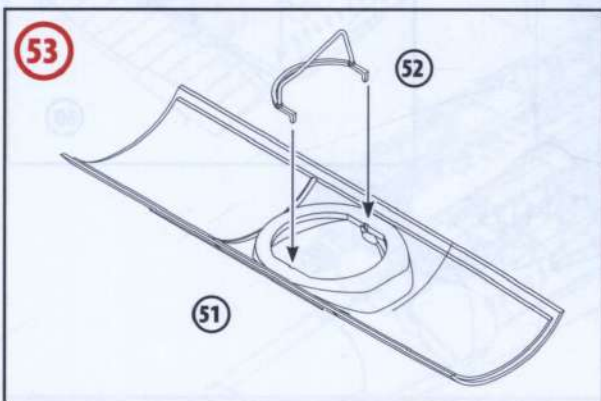
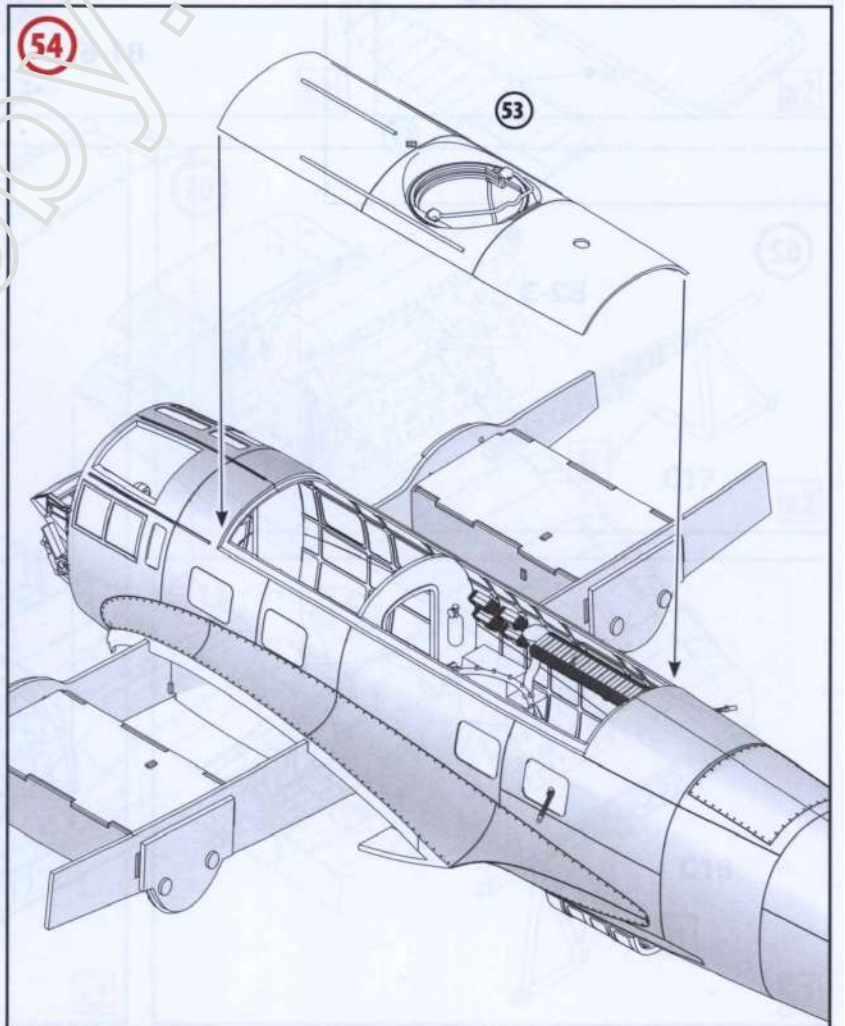
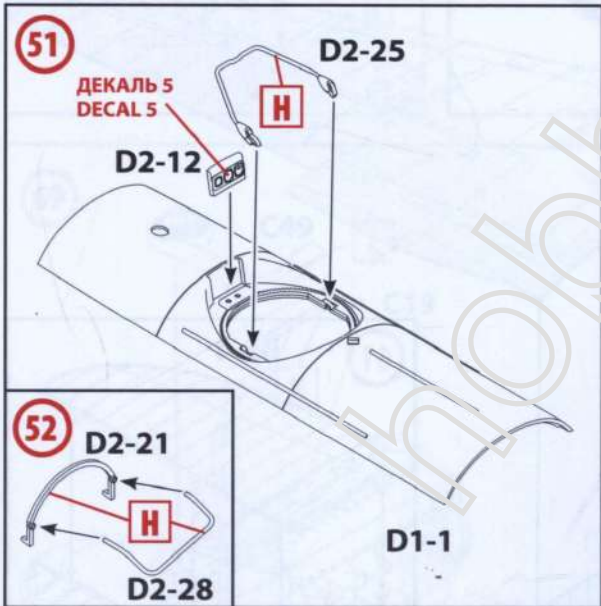
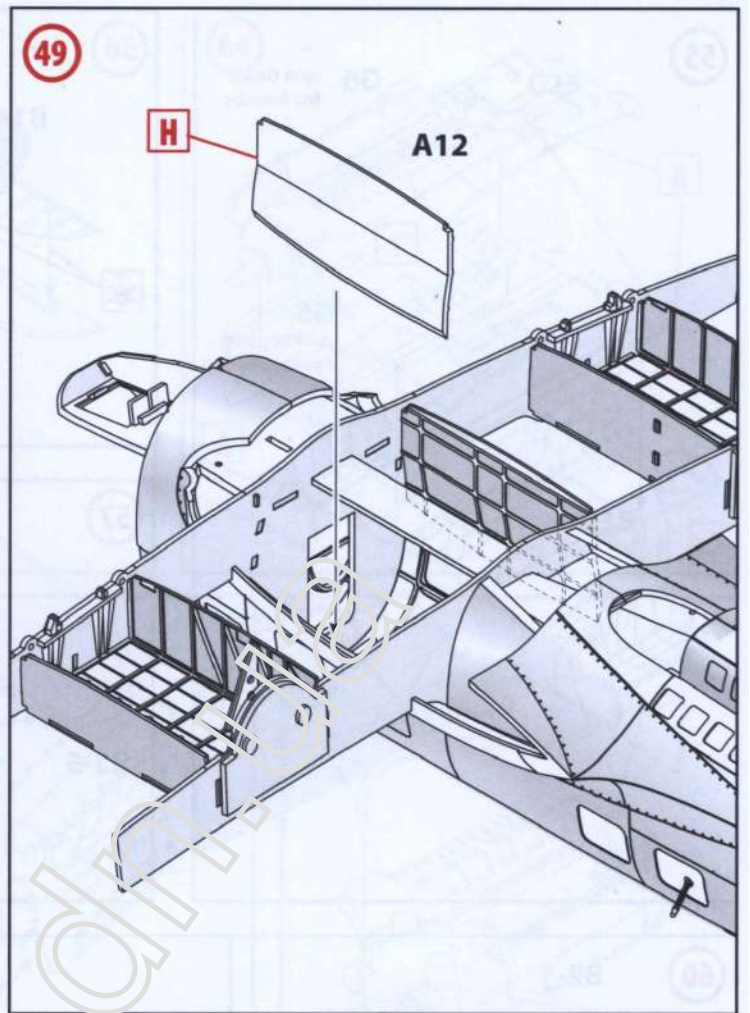
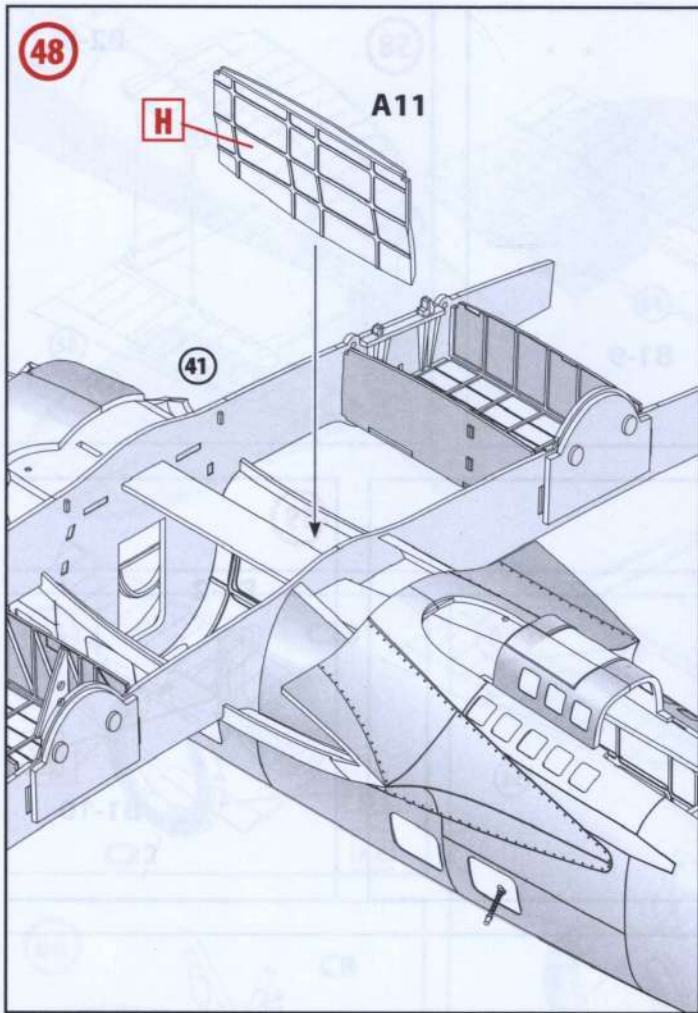

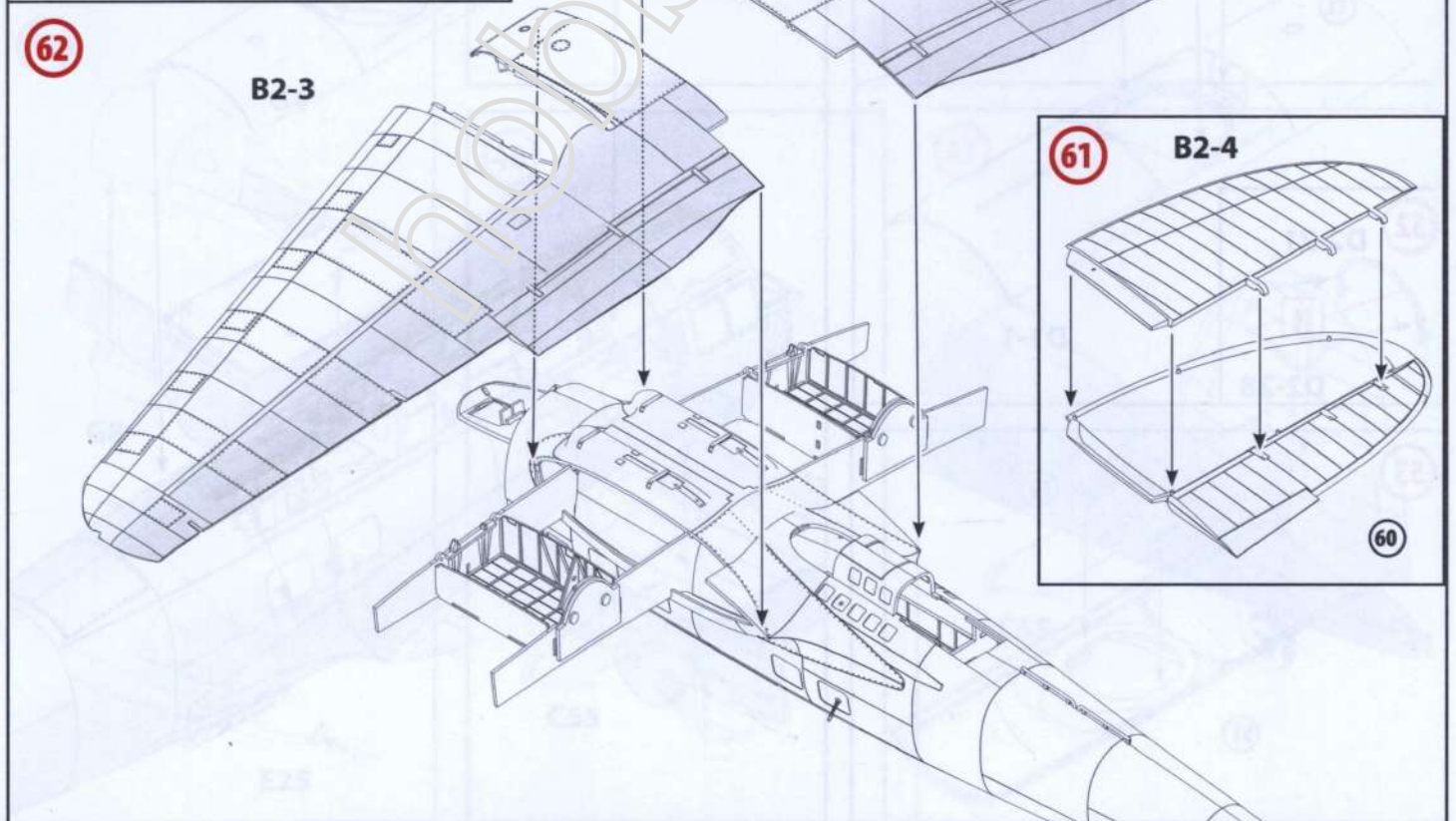
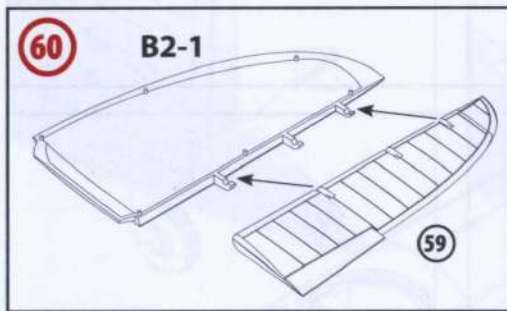
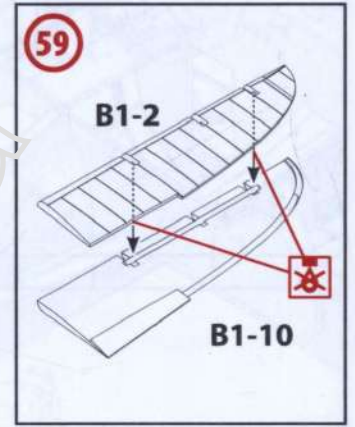
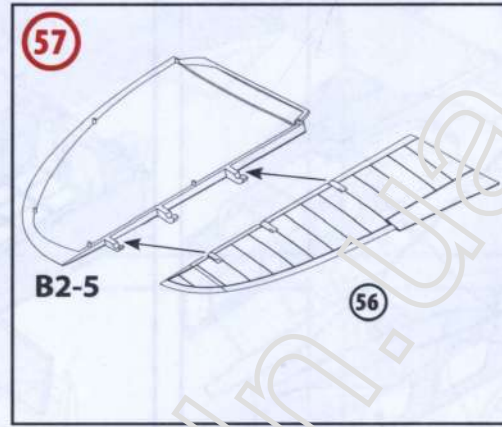
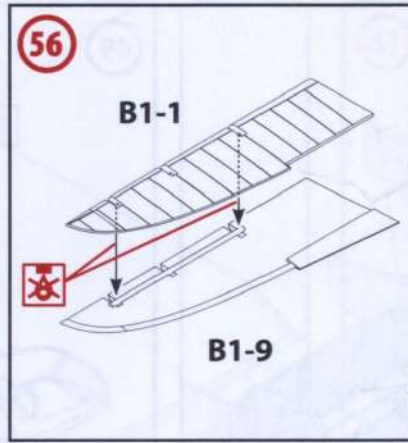
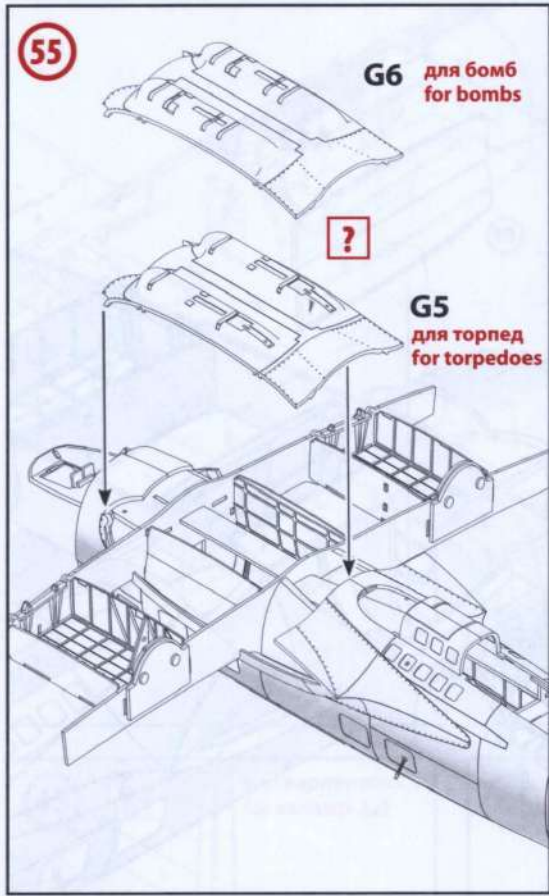

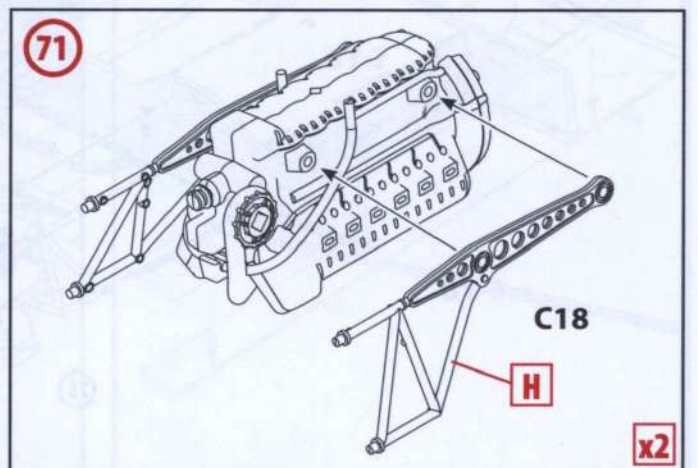
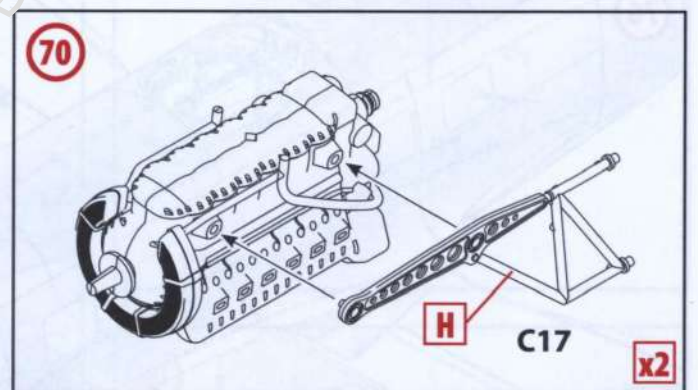
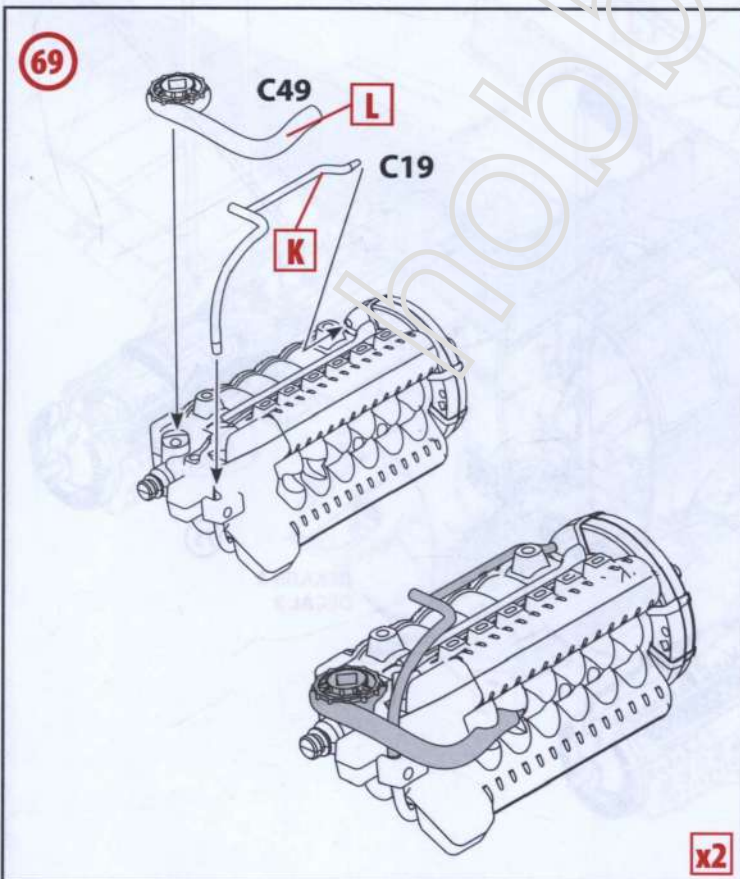
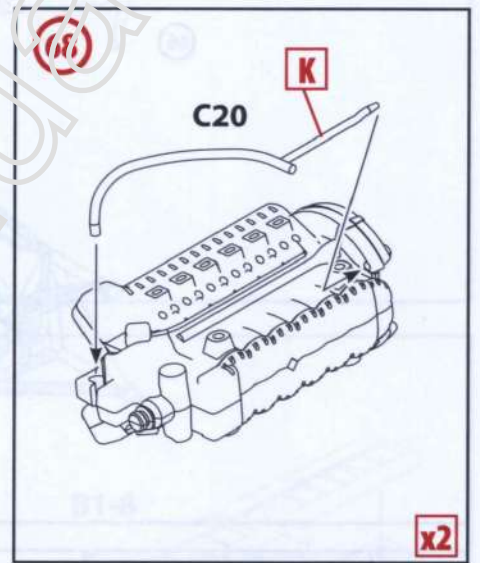
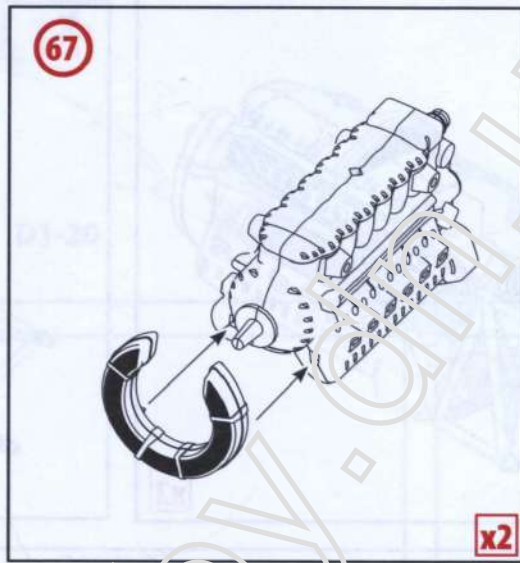
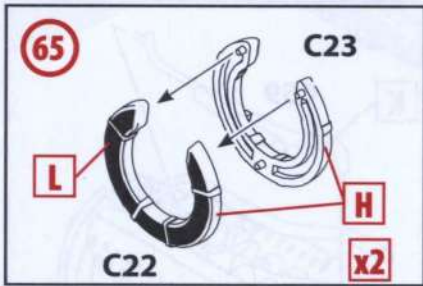
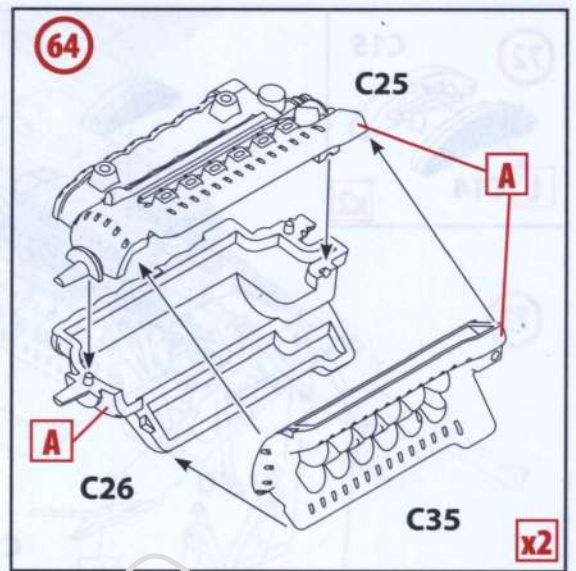
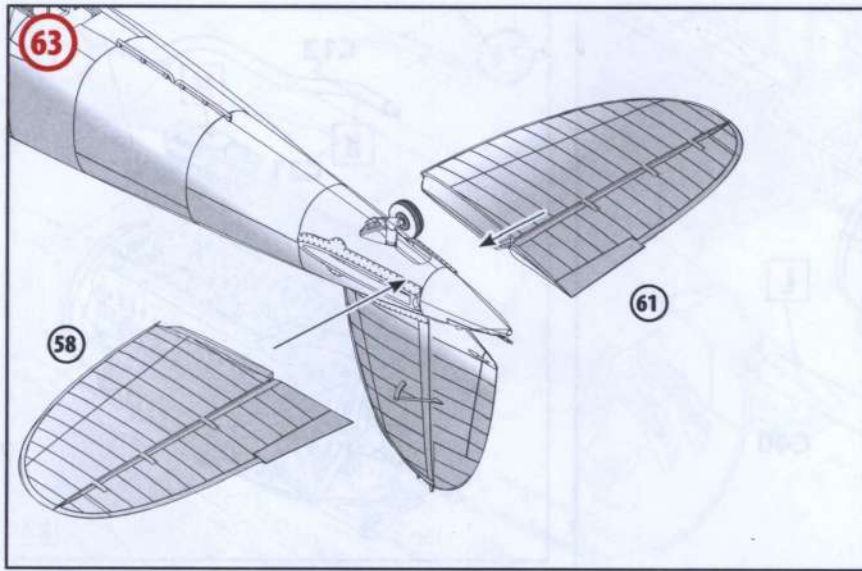

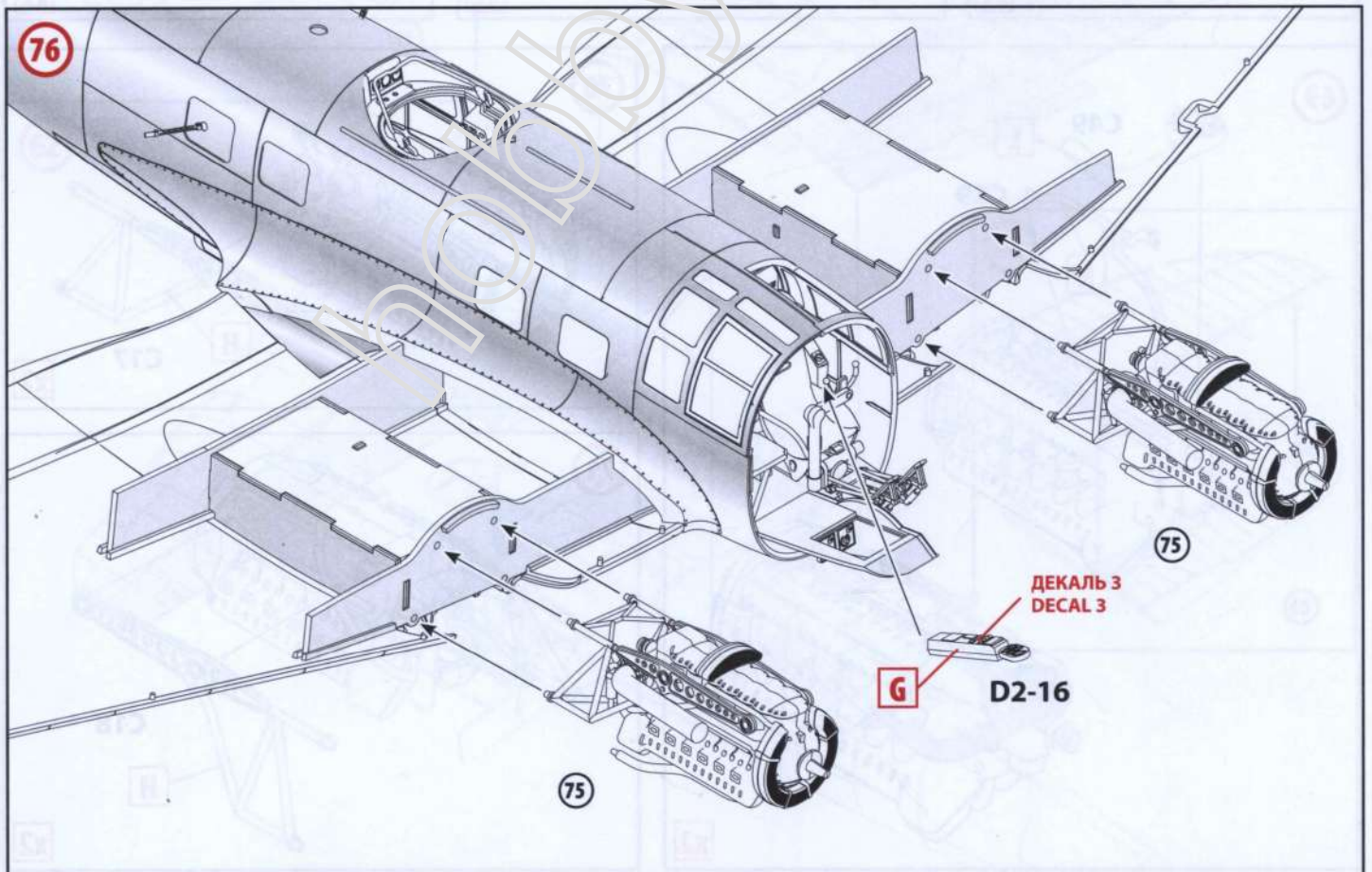
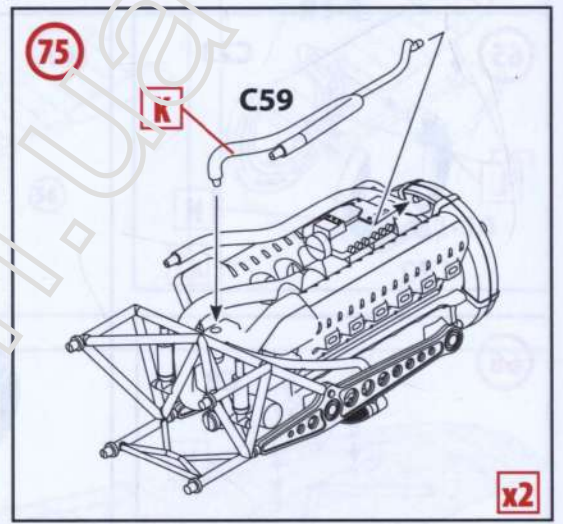
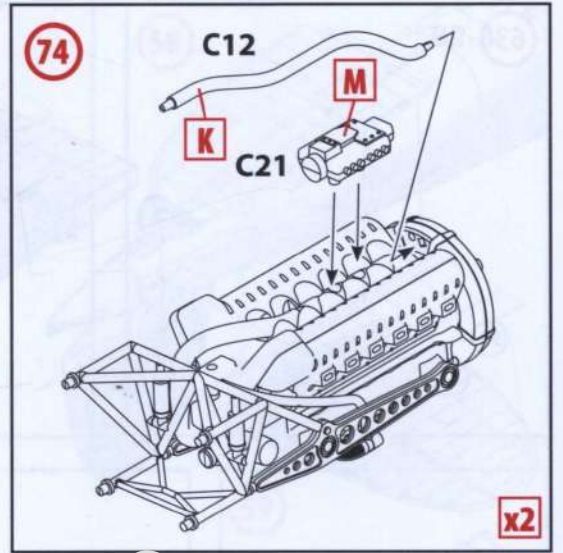
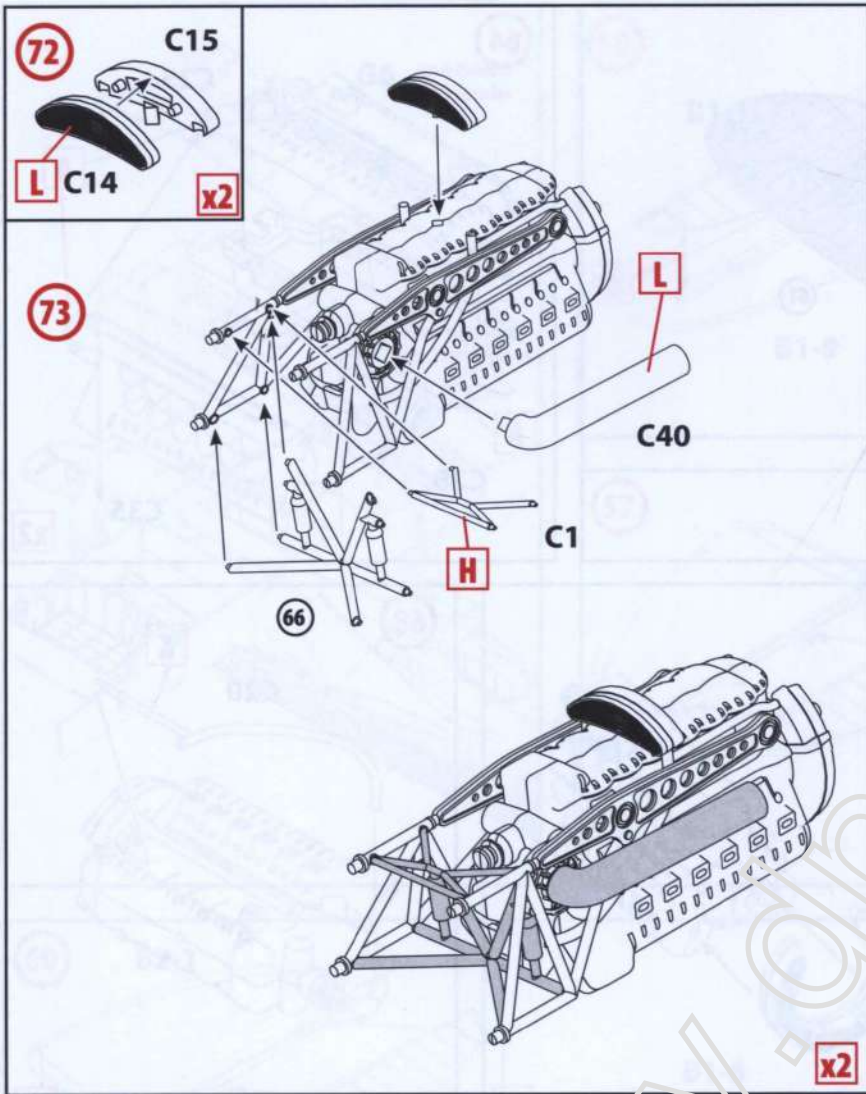

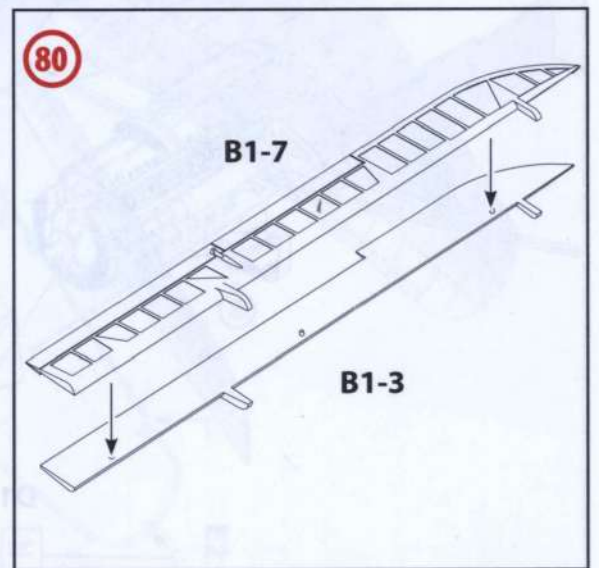
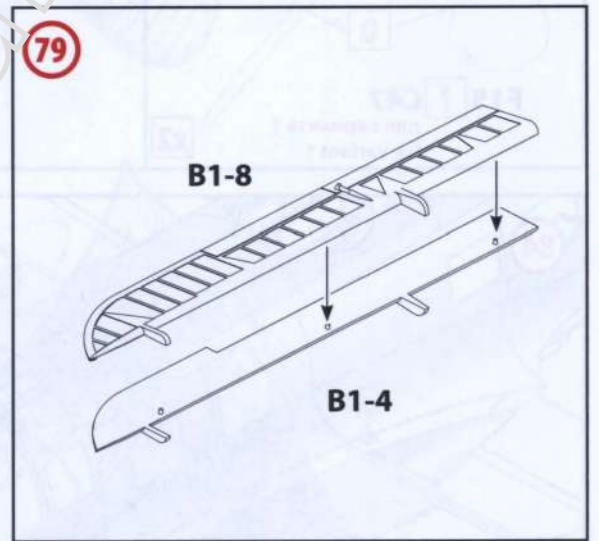
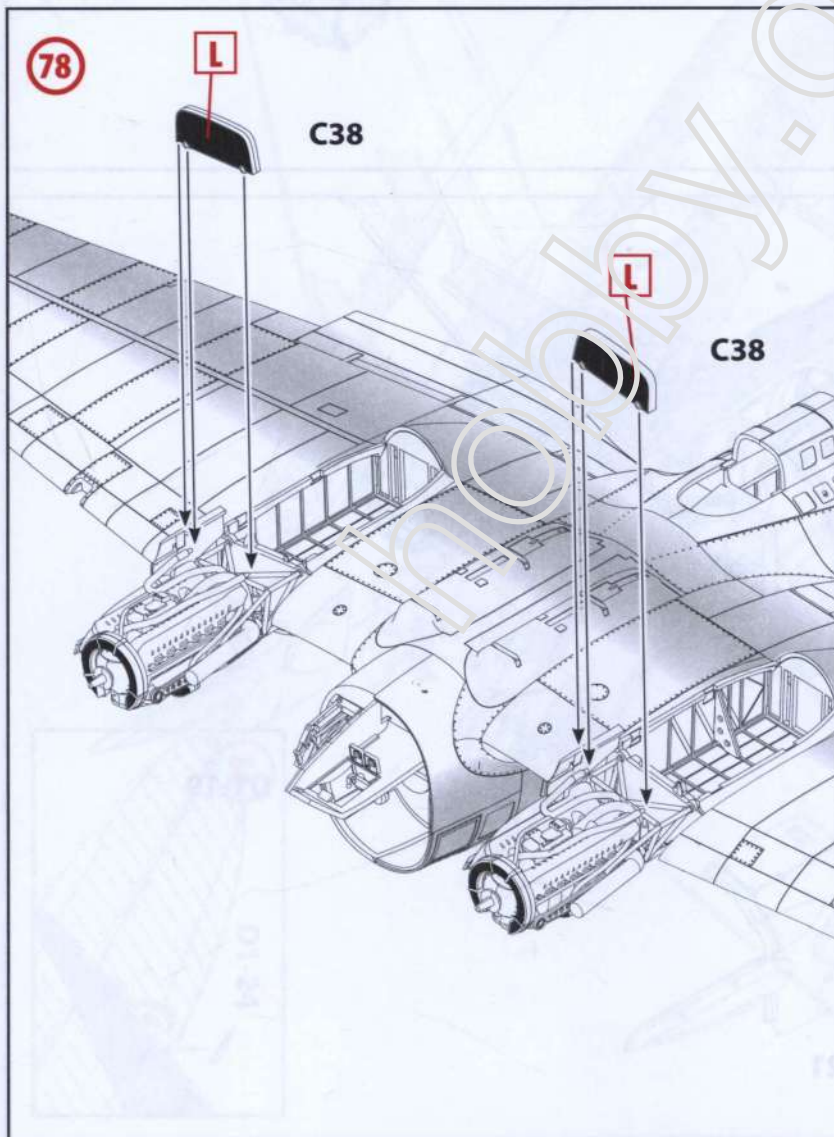
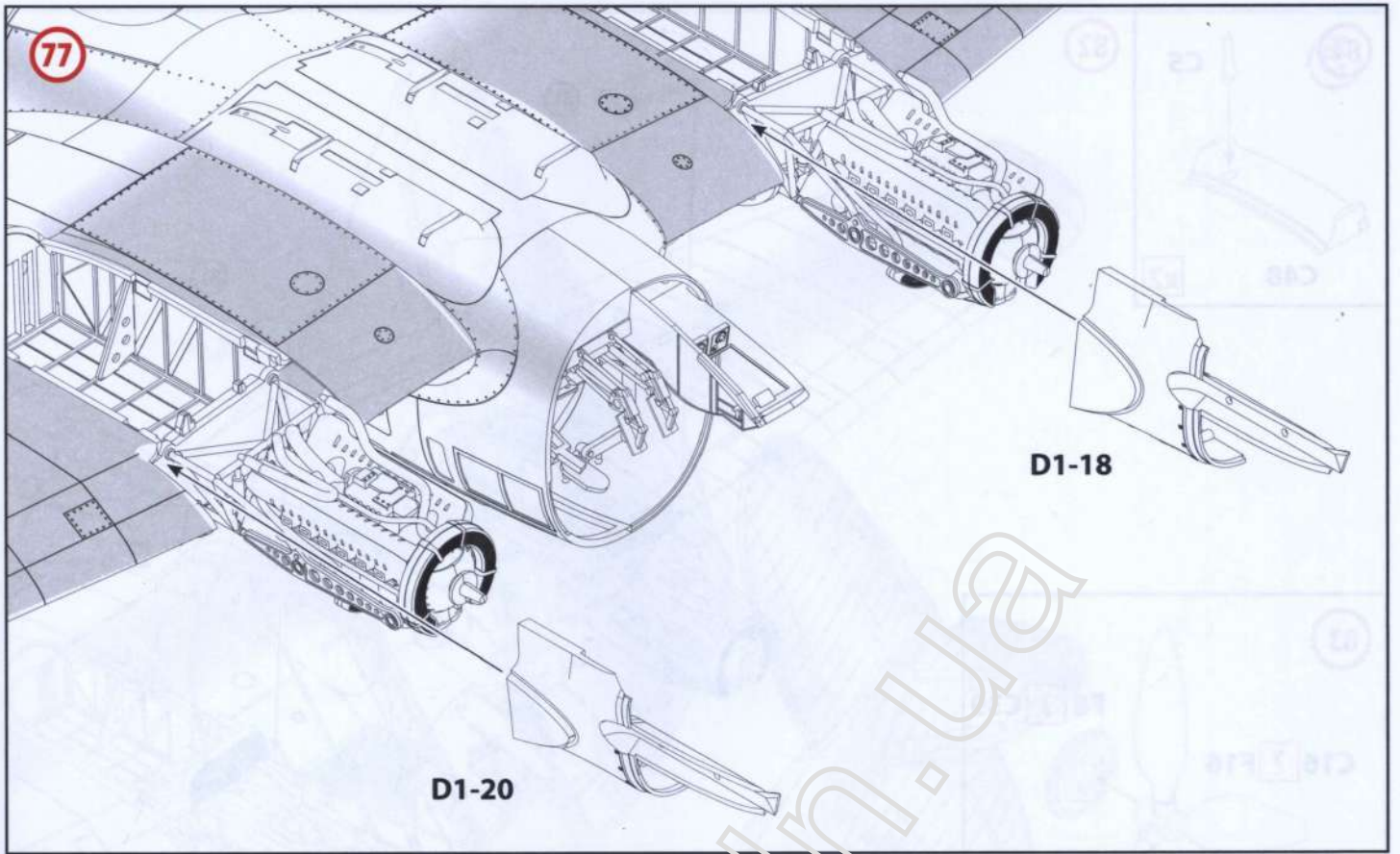

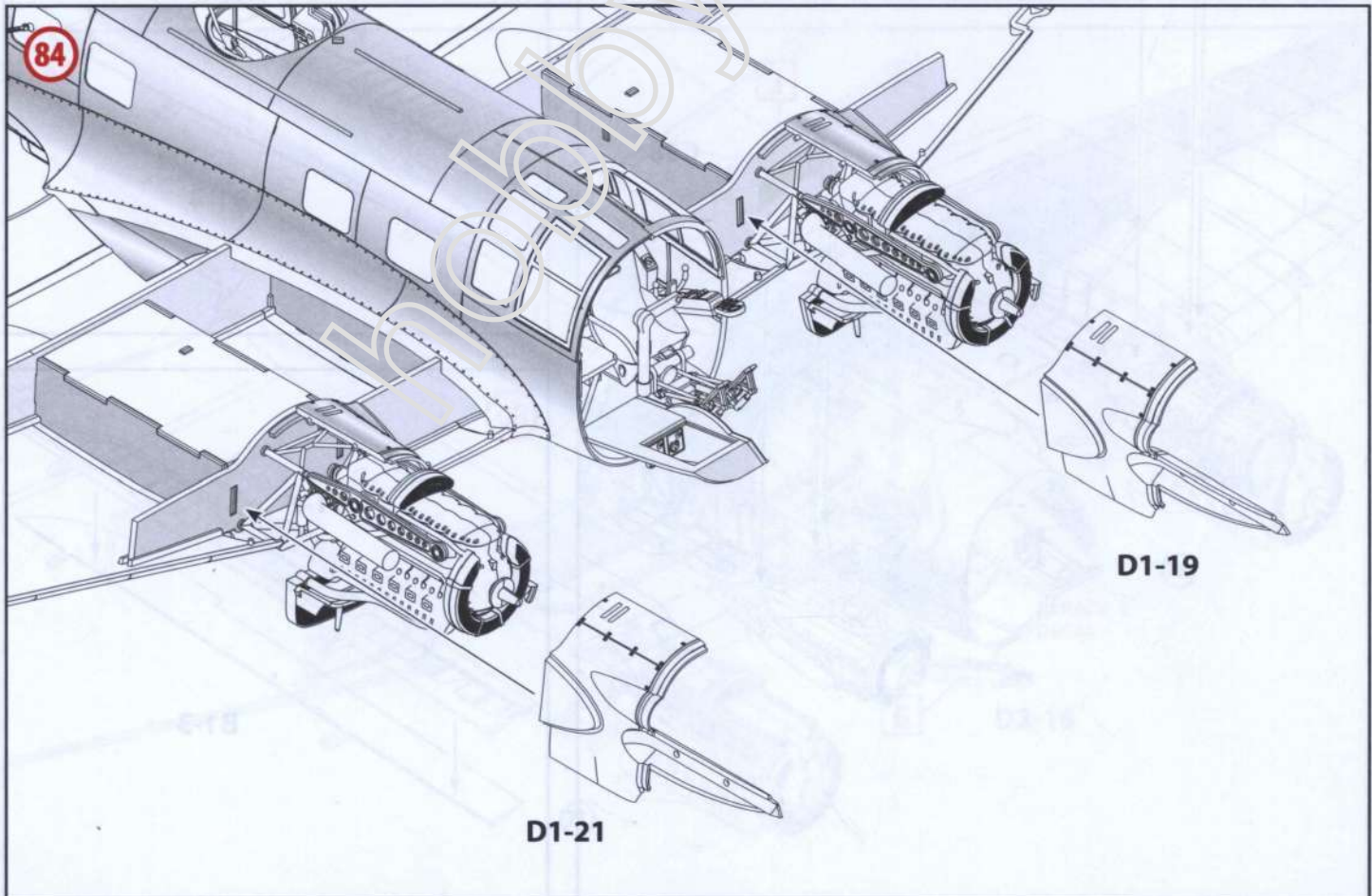
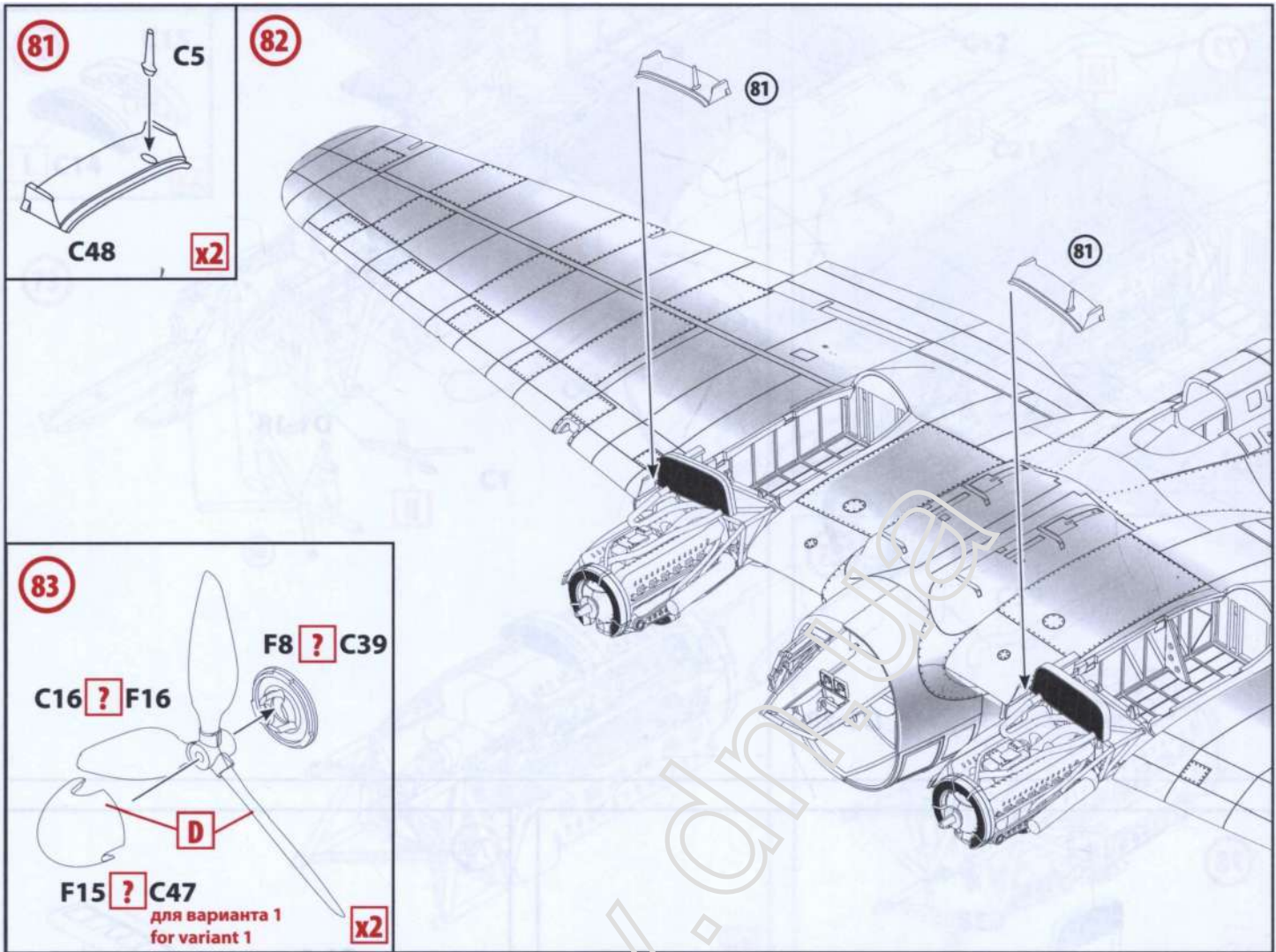



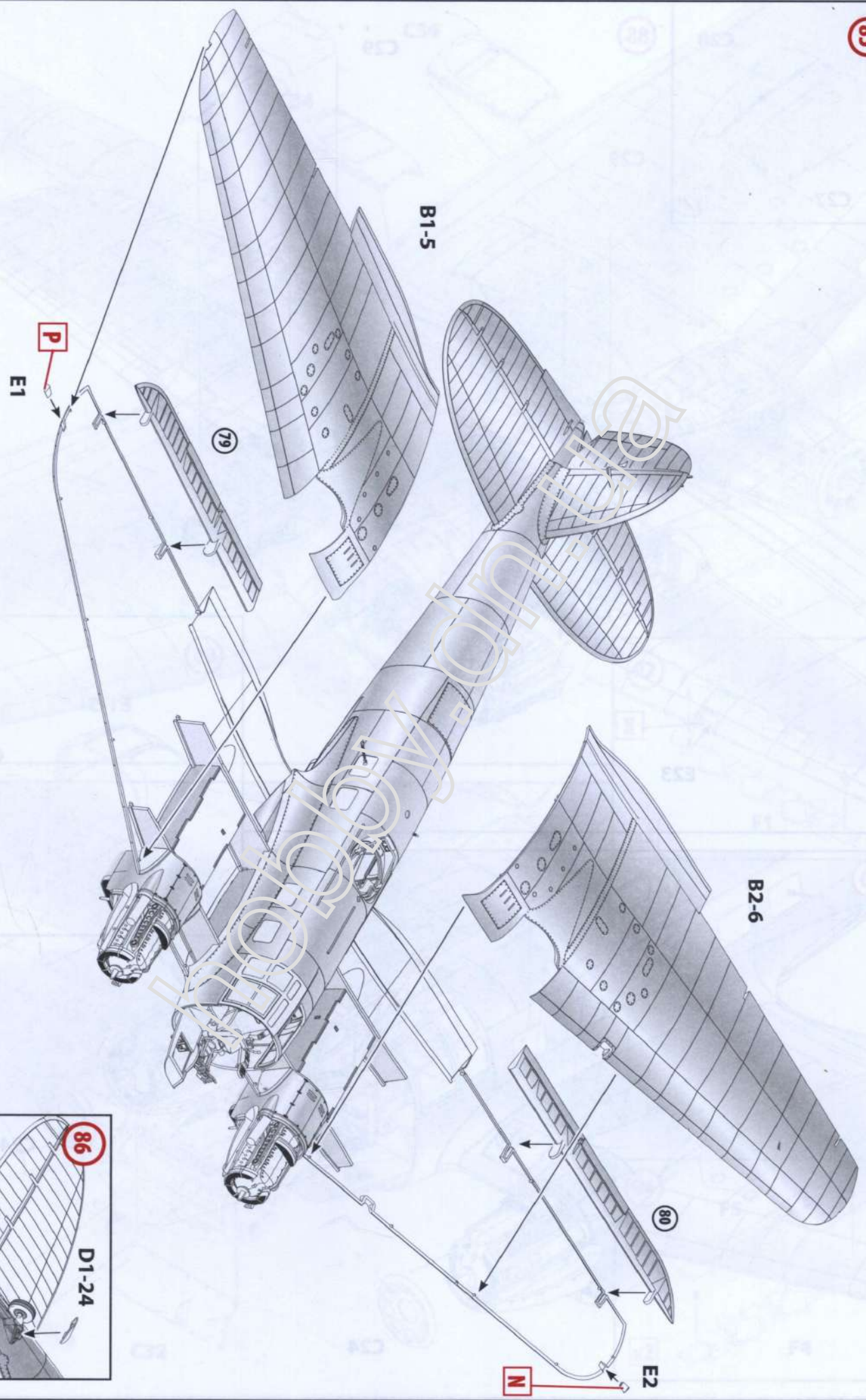

B1-5

B2-6

P  
E1

N  
E2

79

80

86

D1-24



87

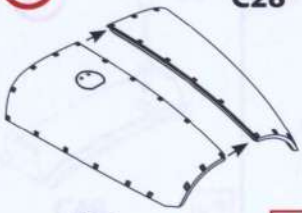

C28

88

C29

C29

C27

x2

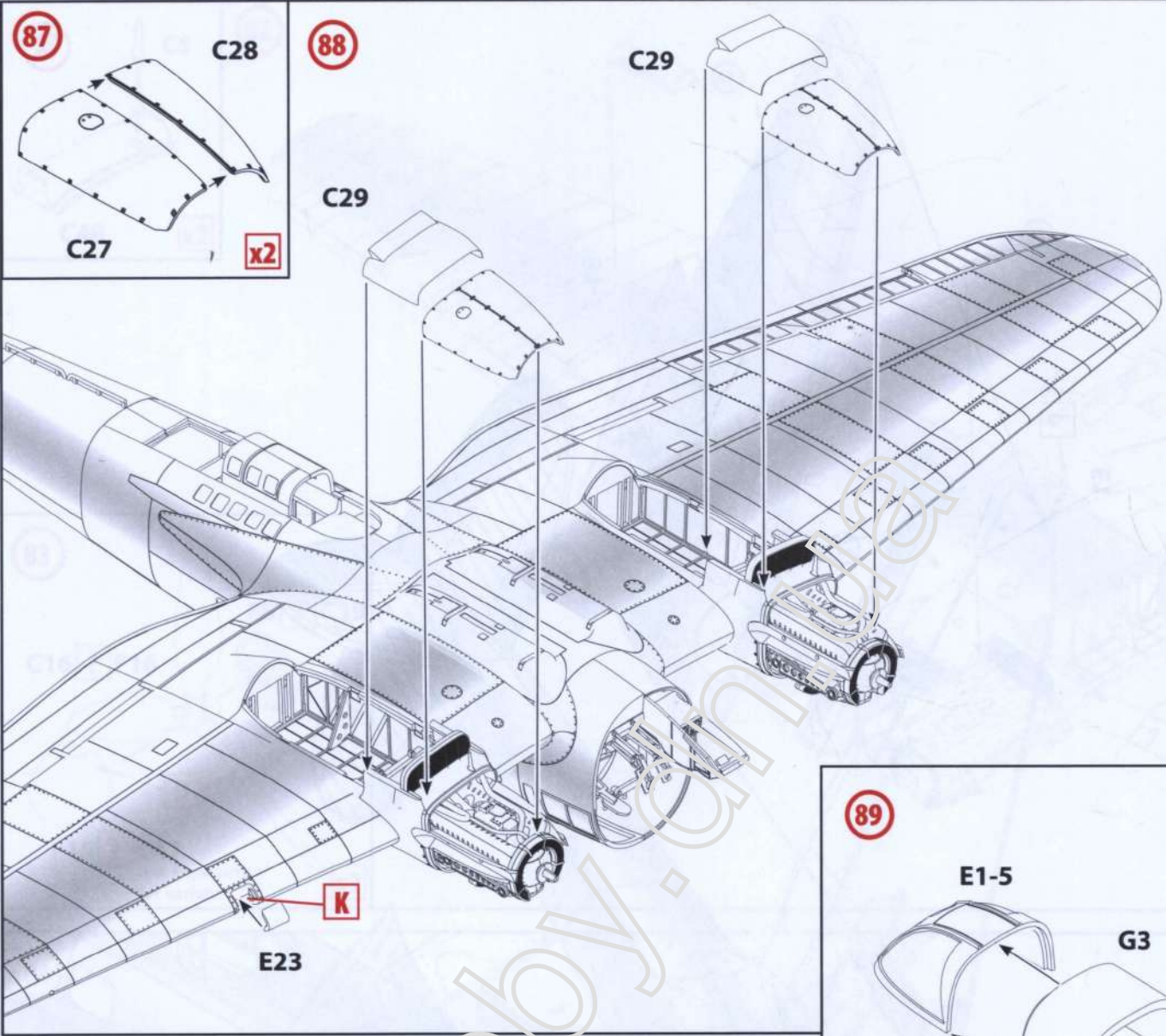

E23

K

89

E1-5

G3

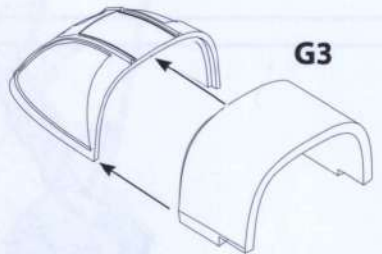

90

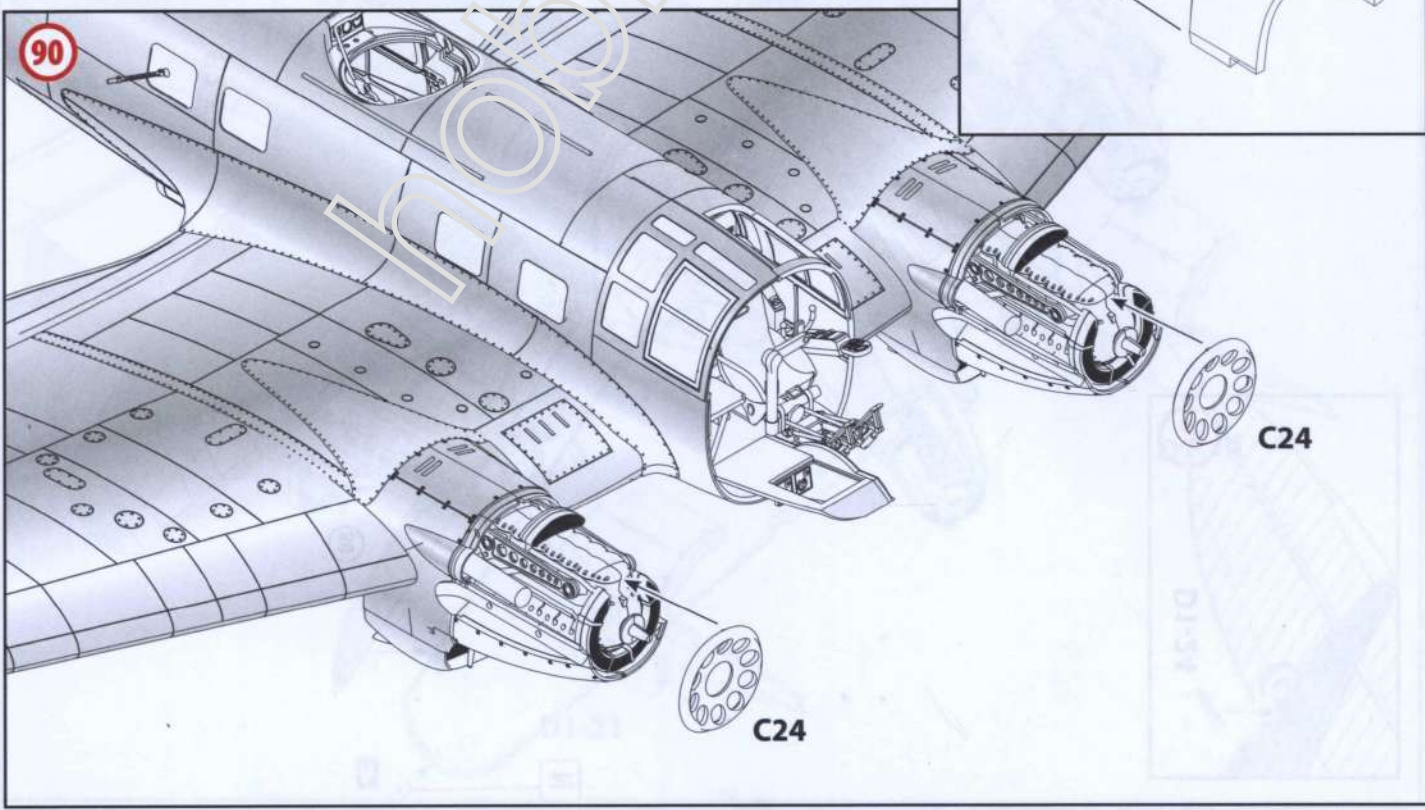

C24

C24

D1-5-1

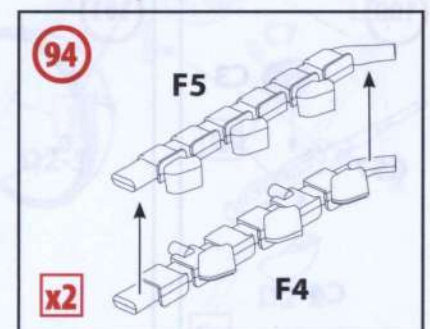
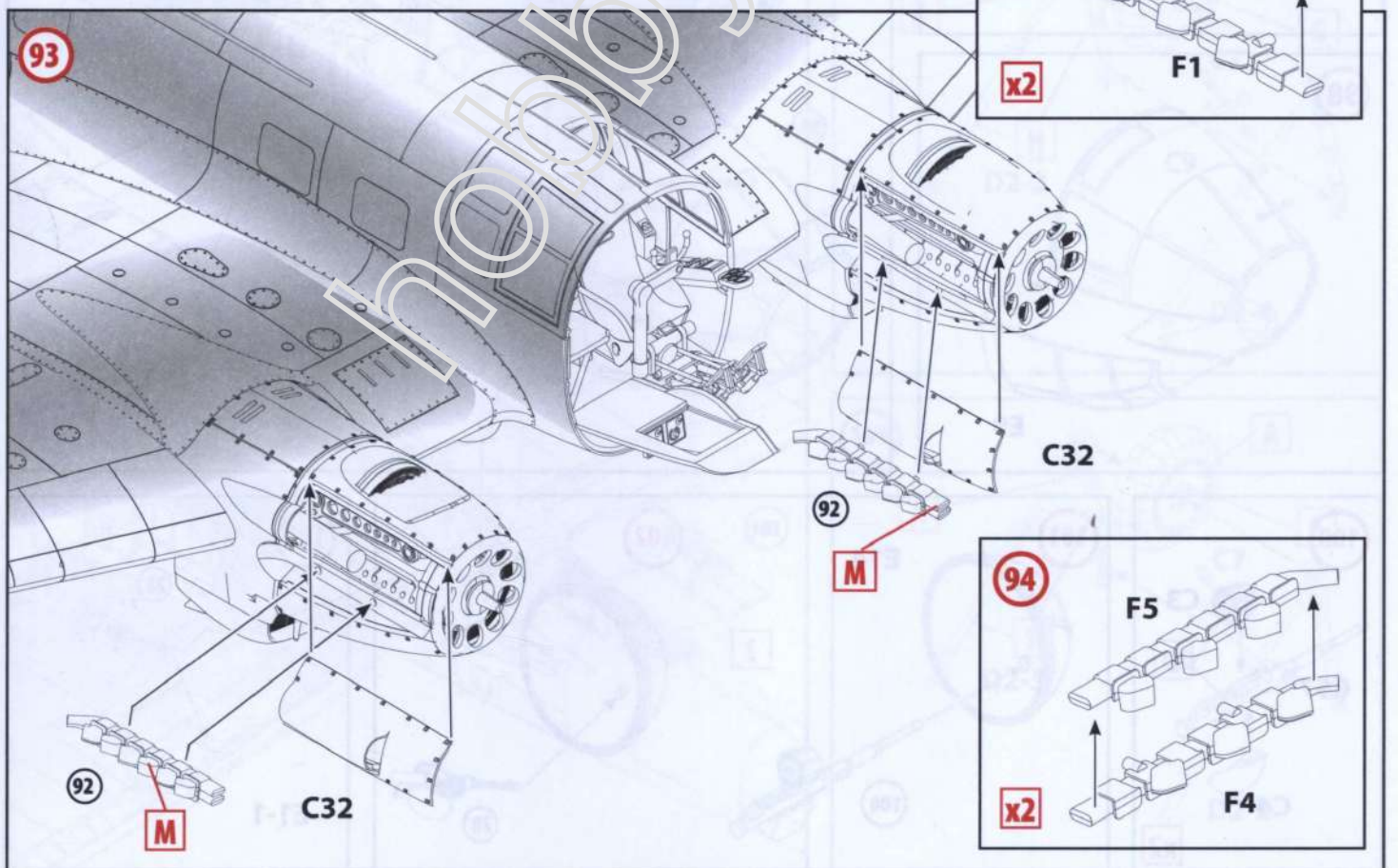
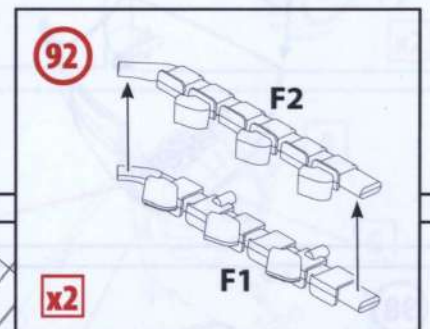
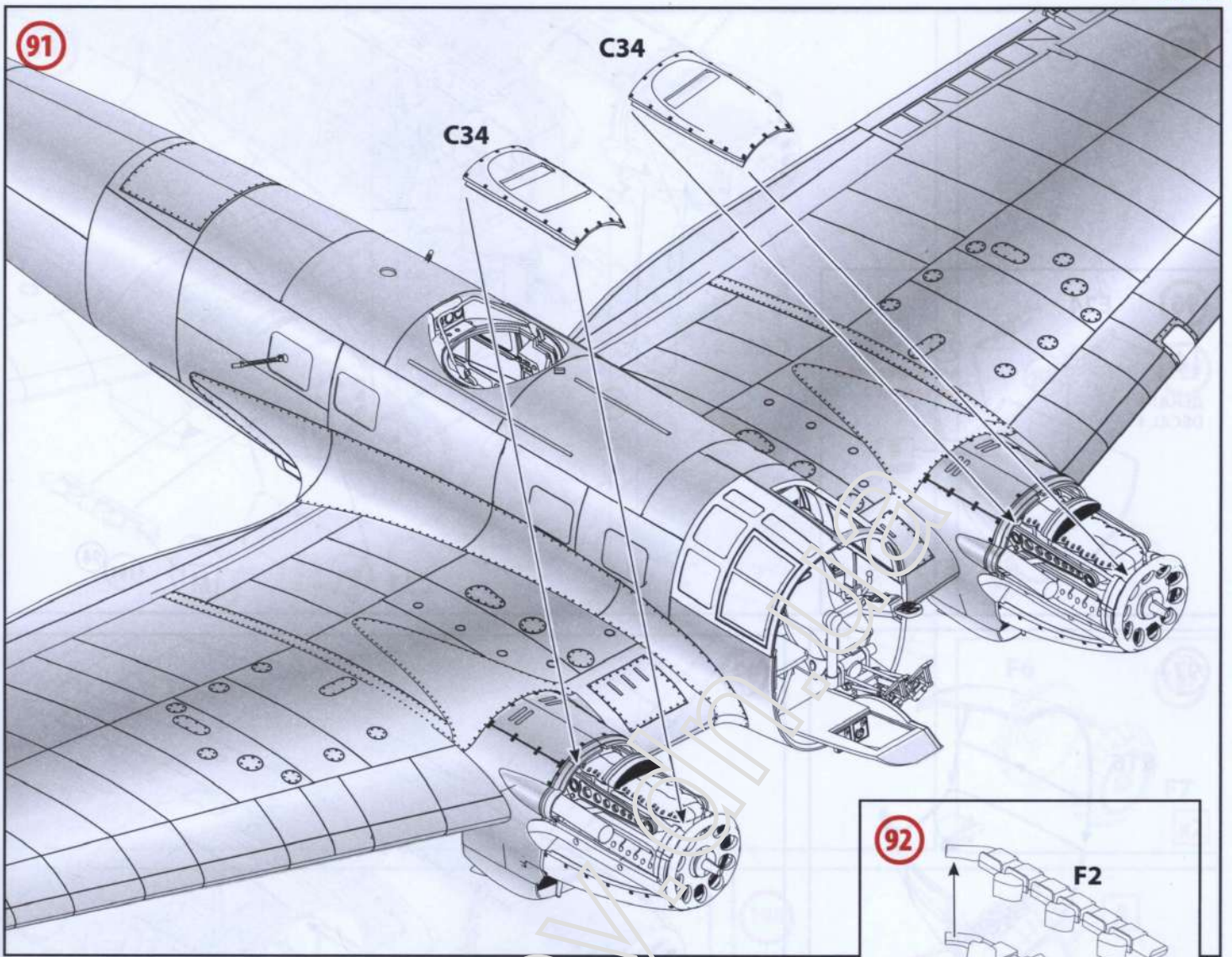

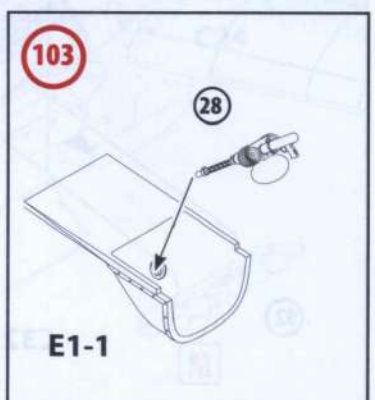
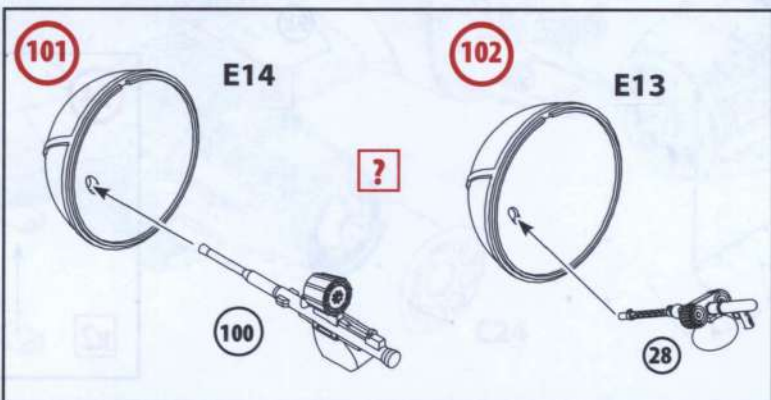
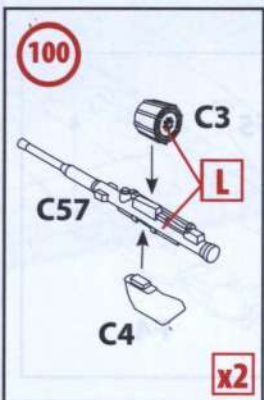
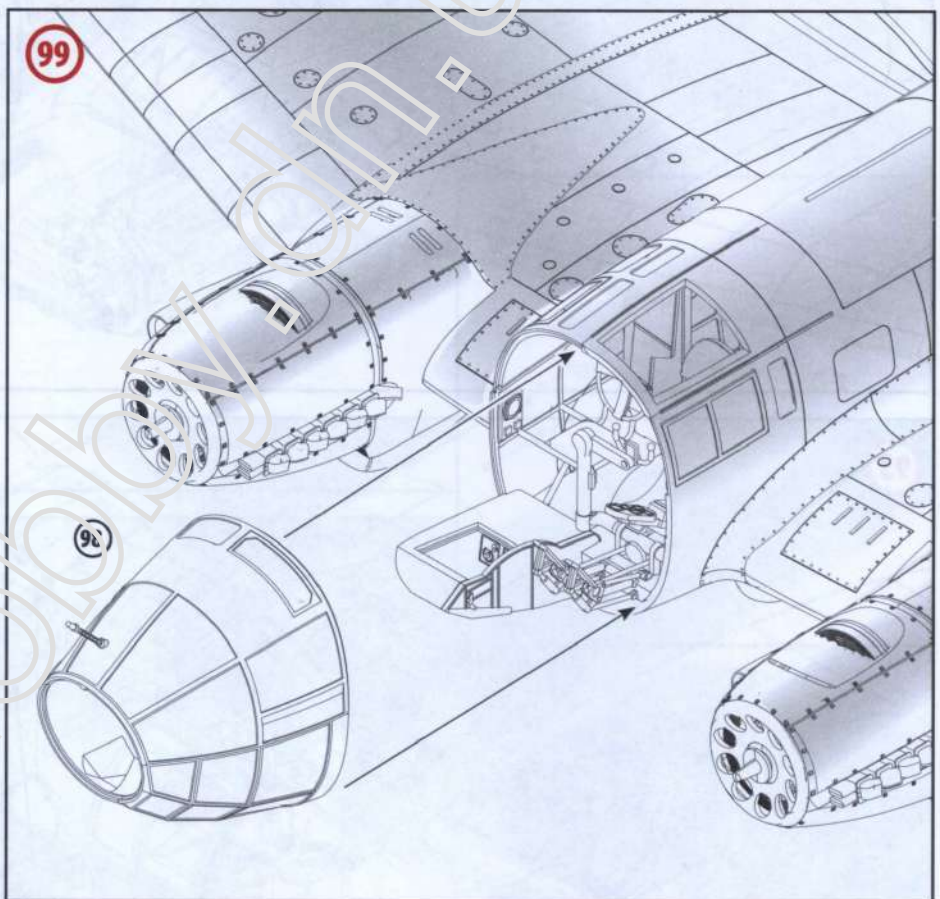
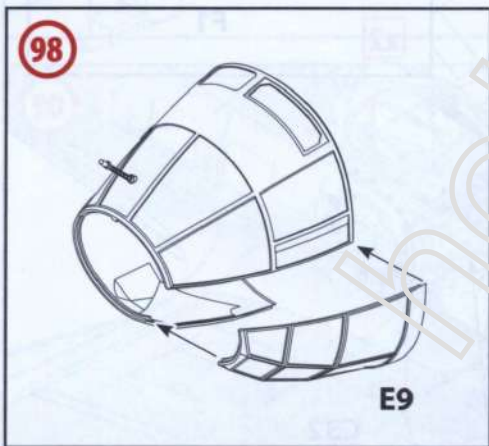
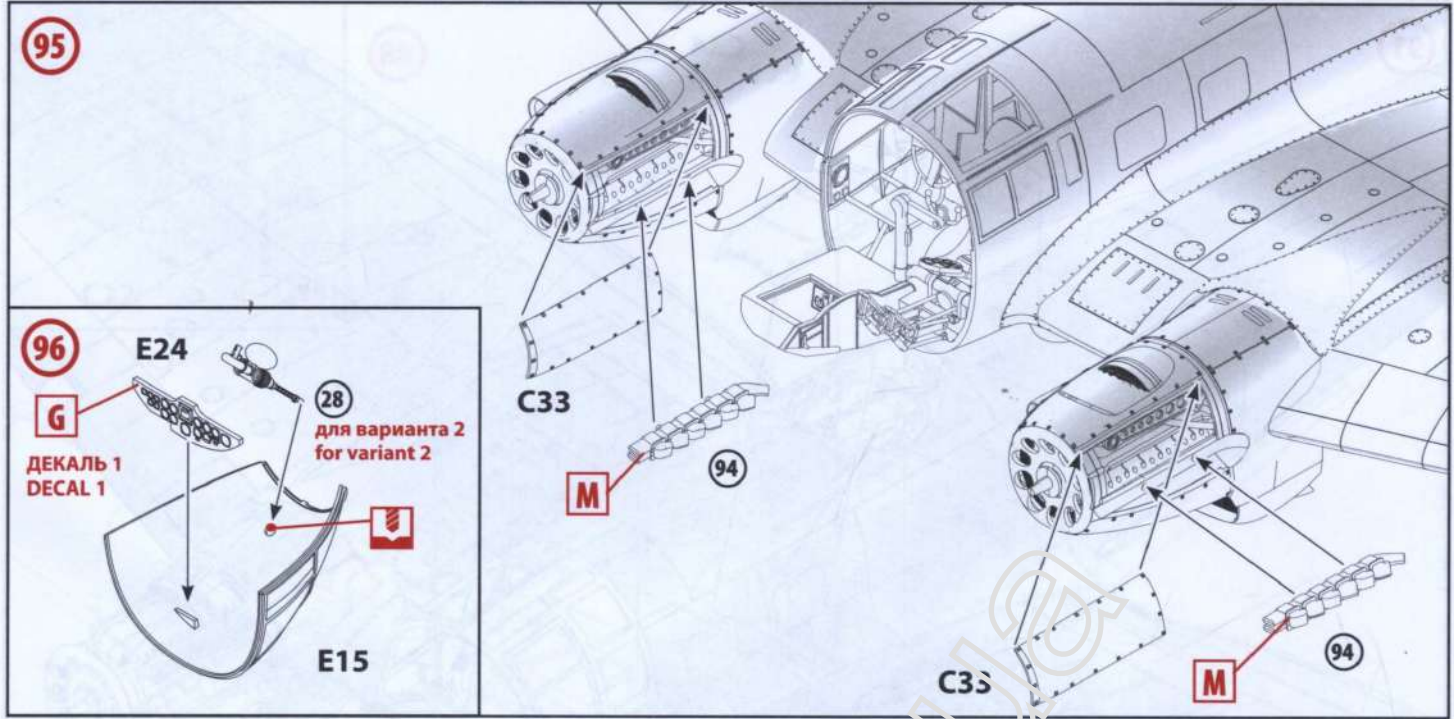

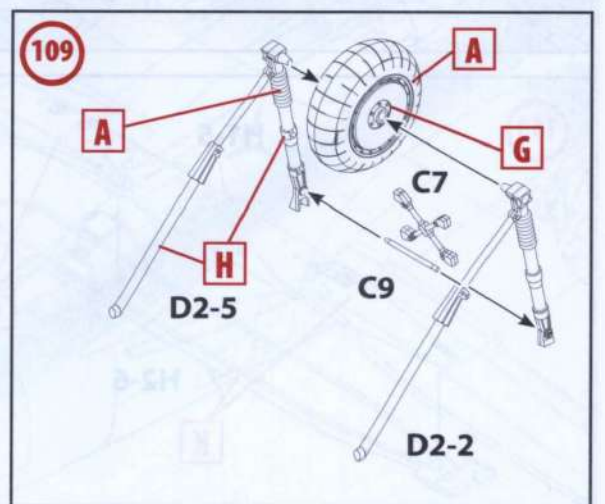
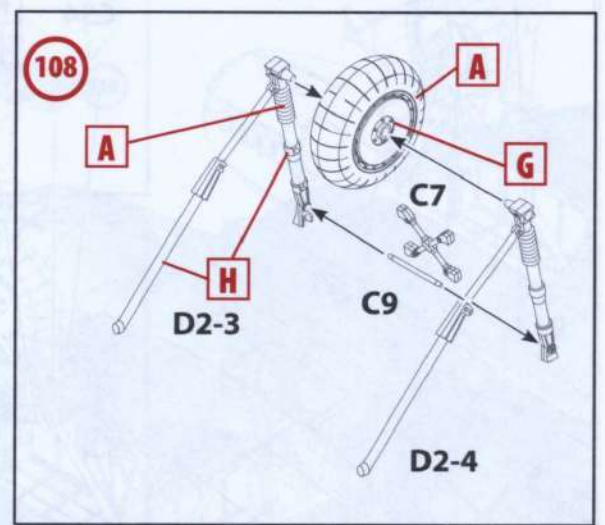
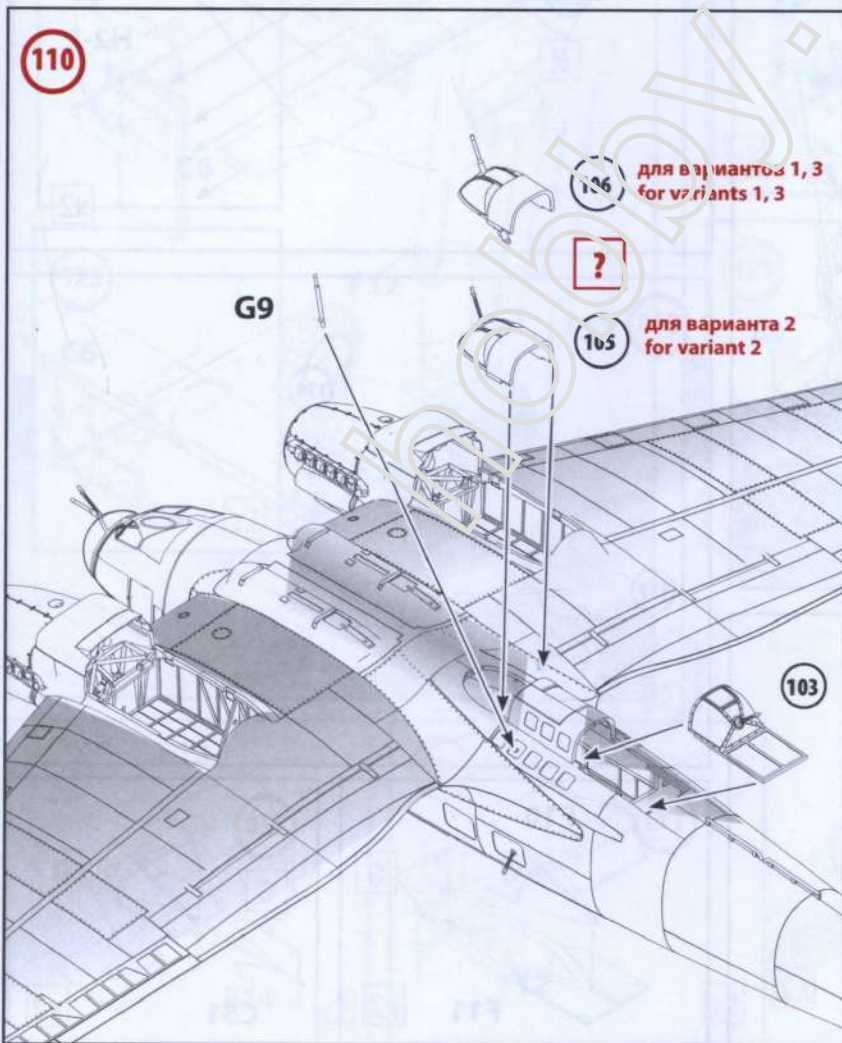
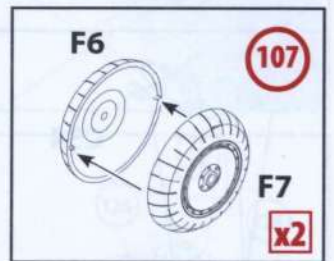
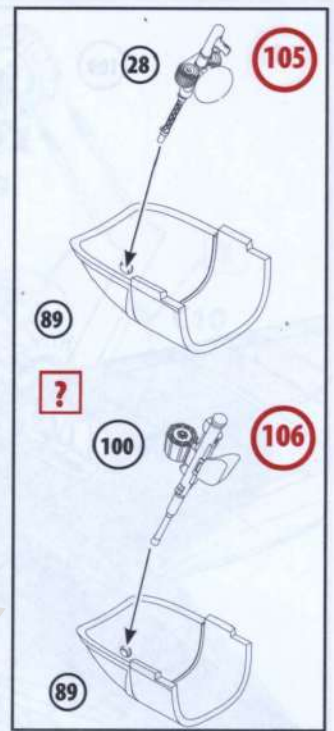
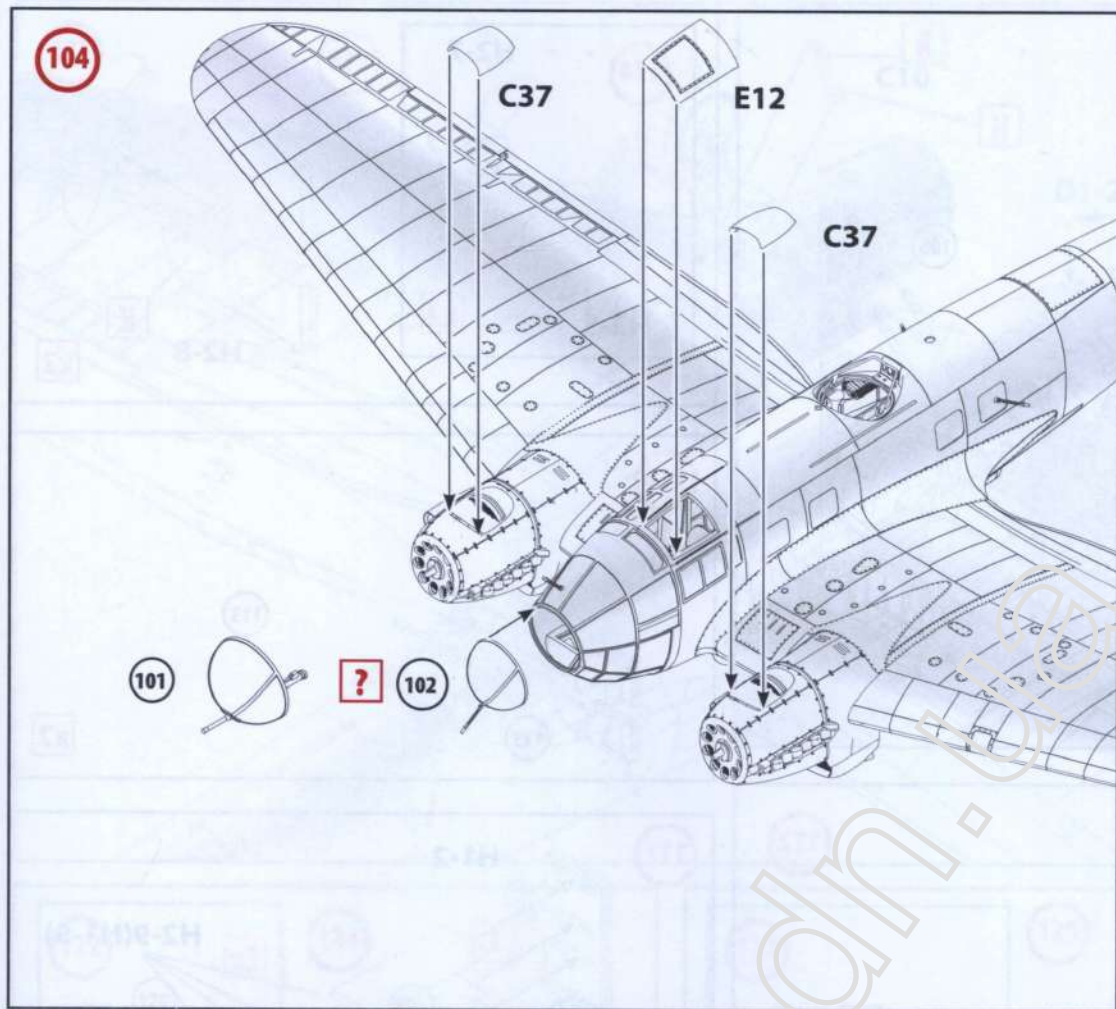

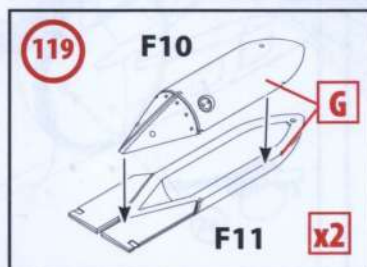
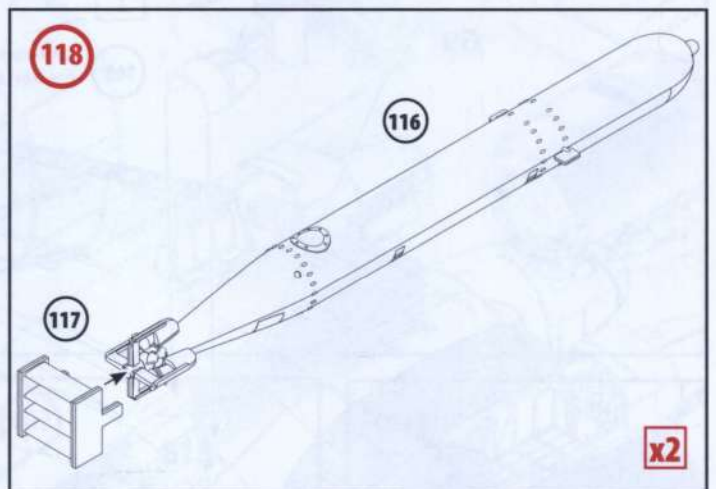
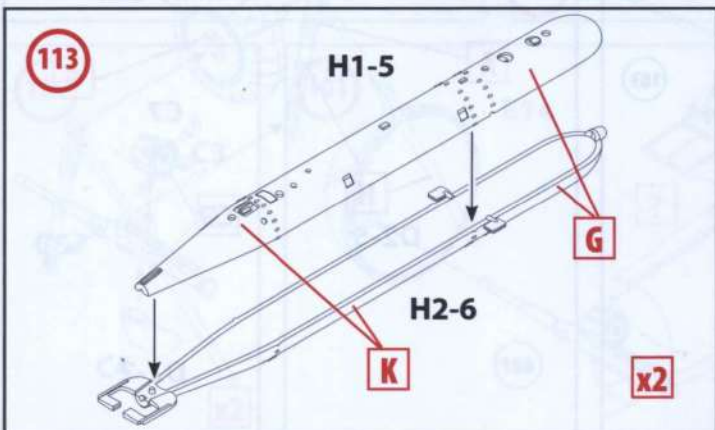
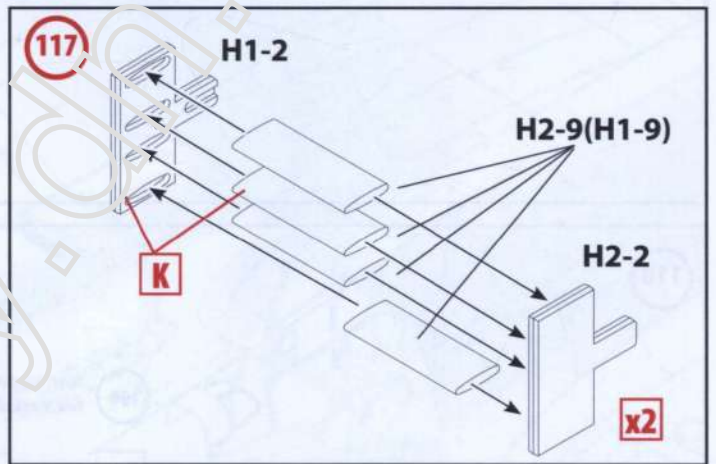
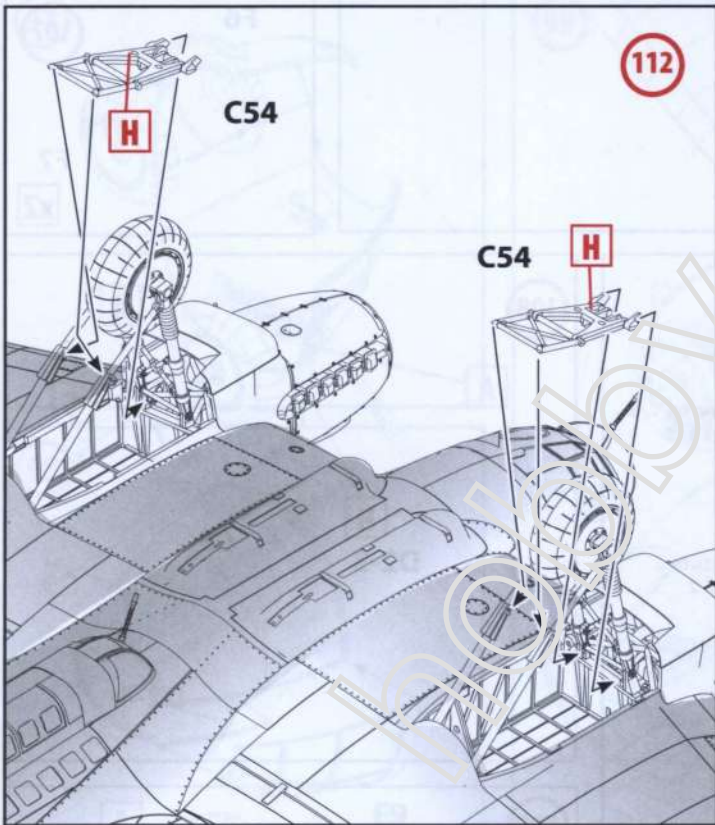
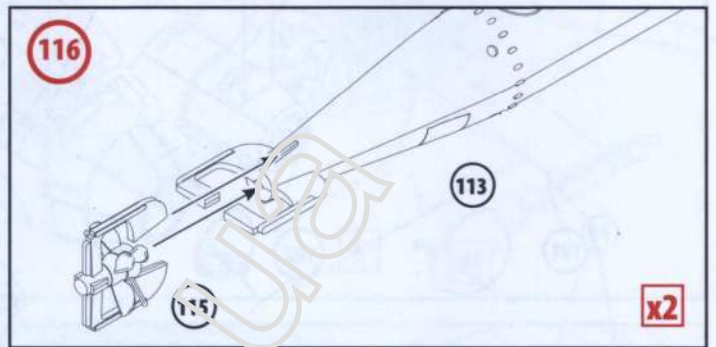
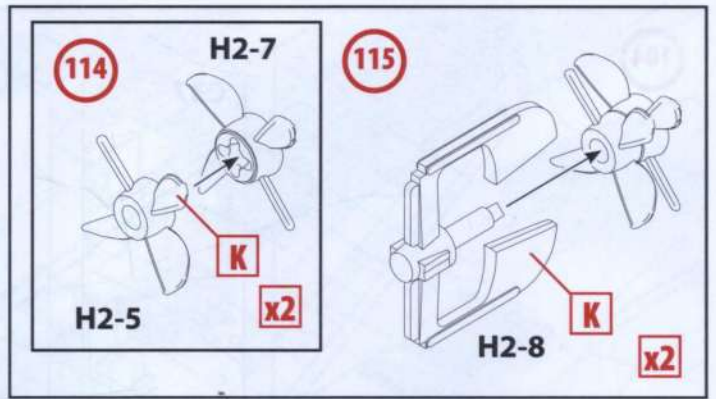
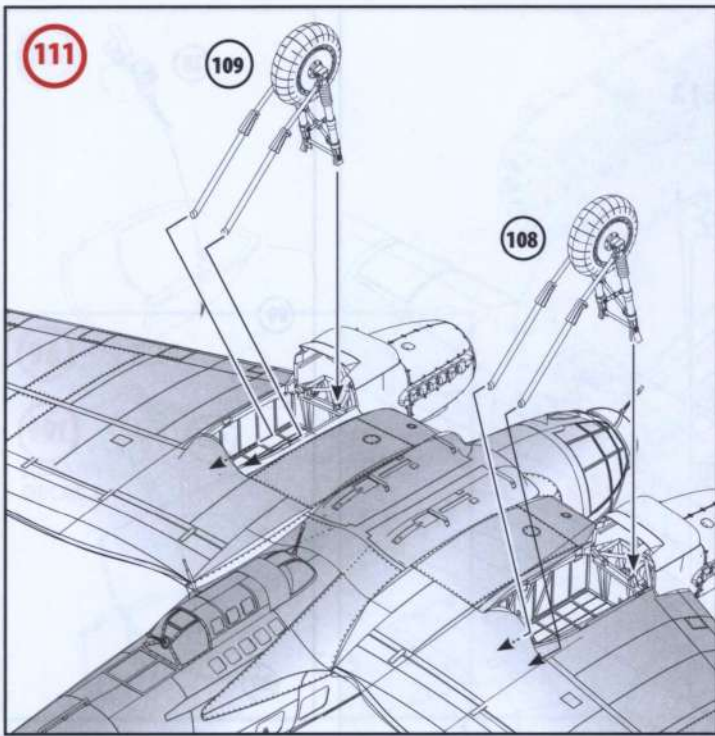

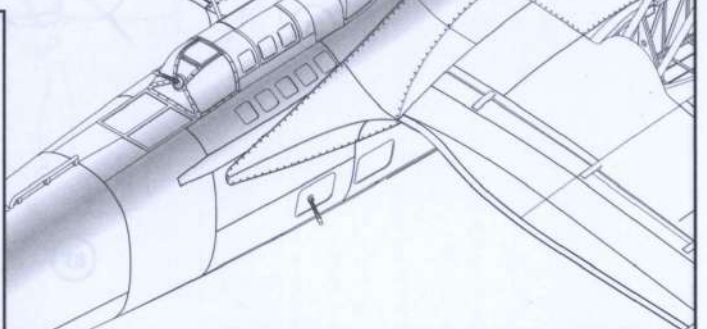
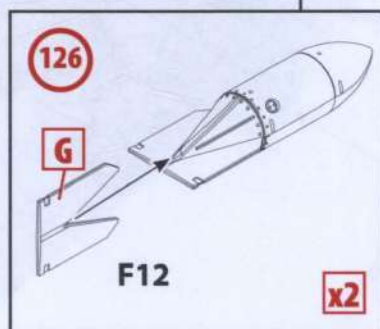
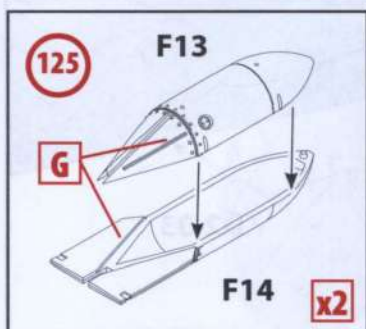
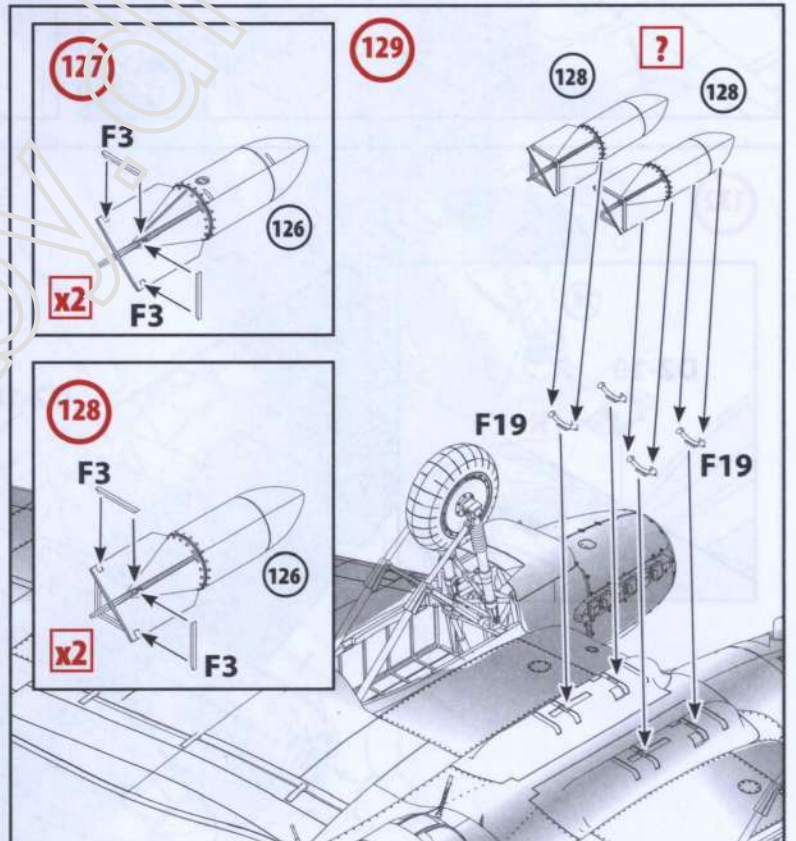
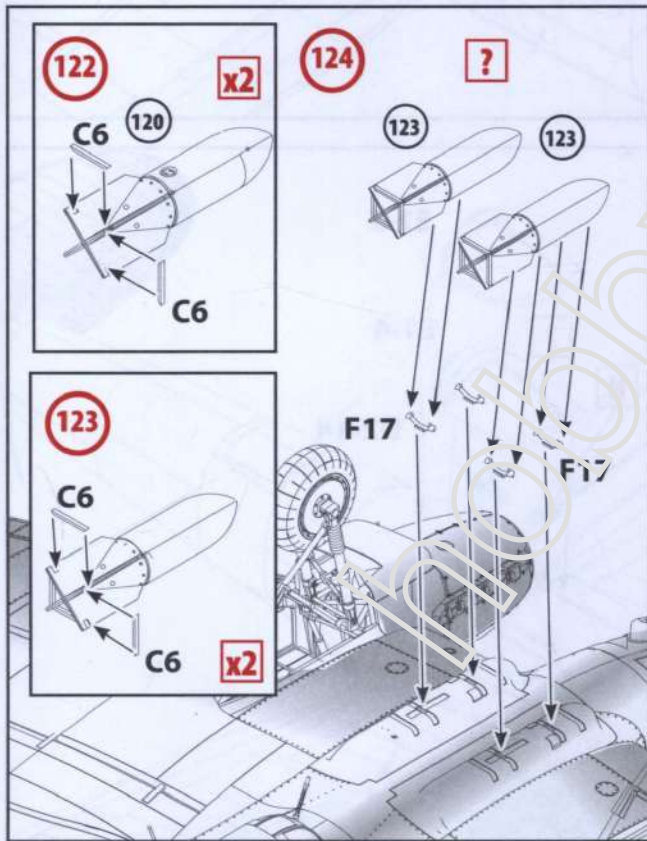
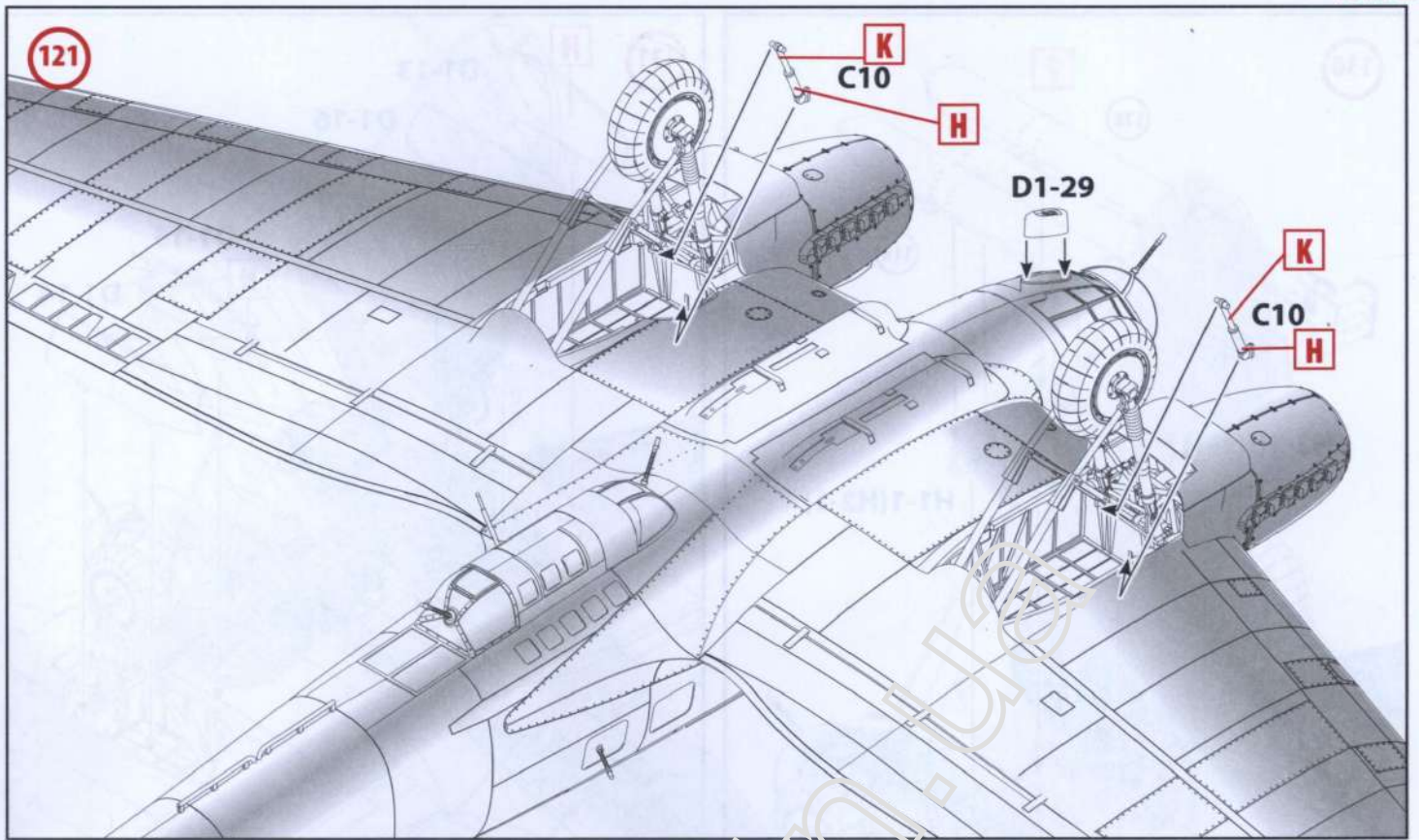

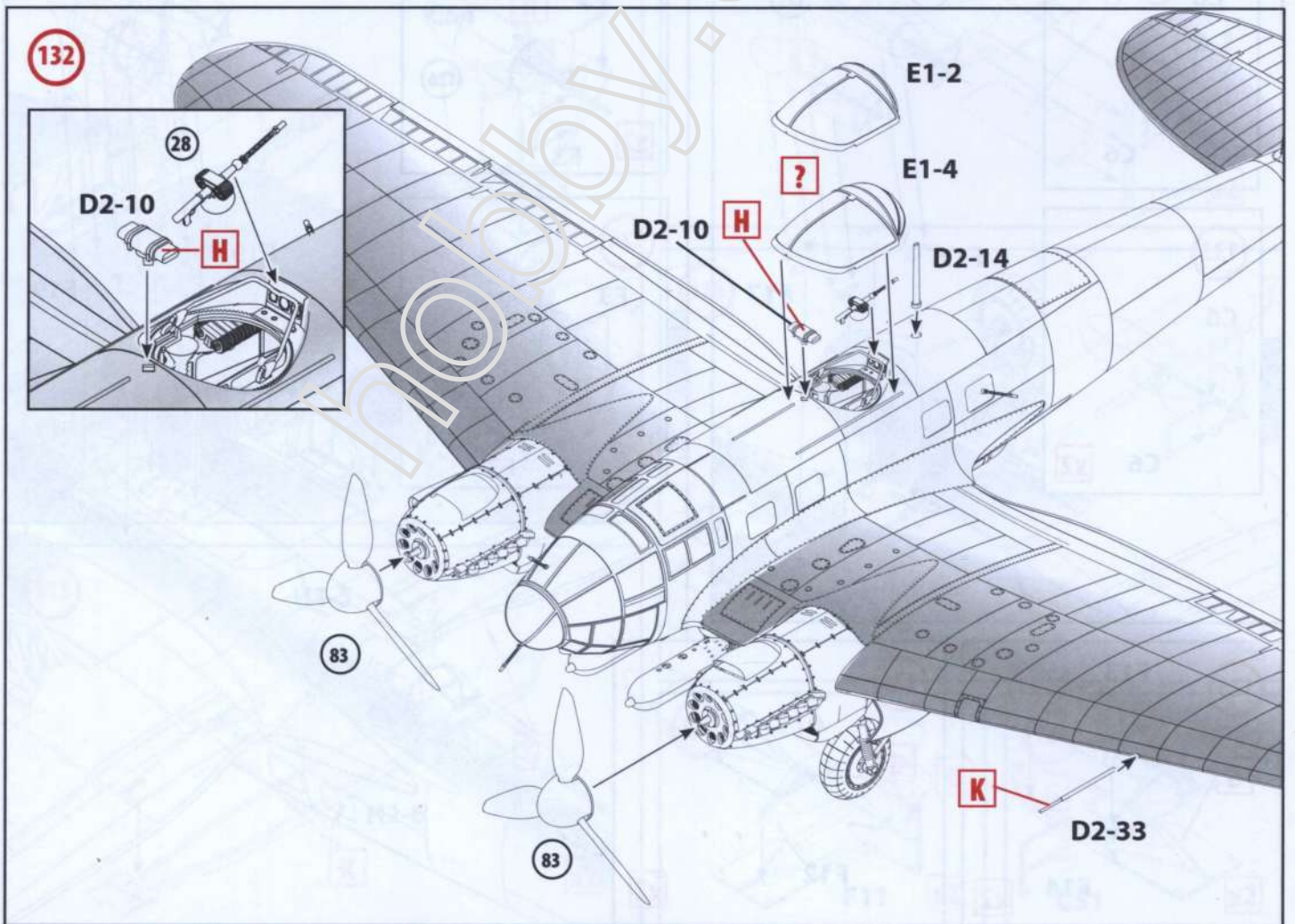
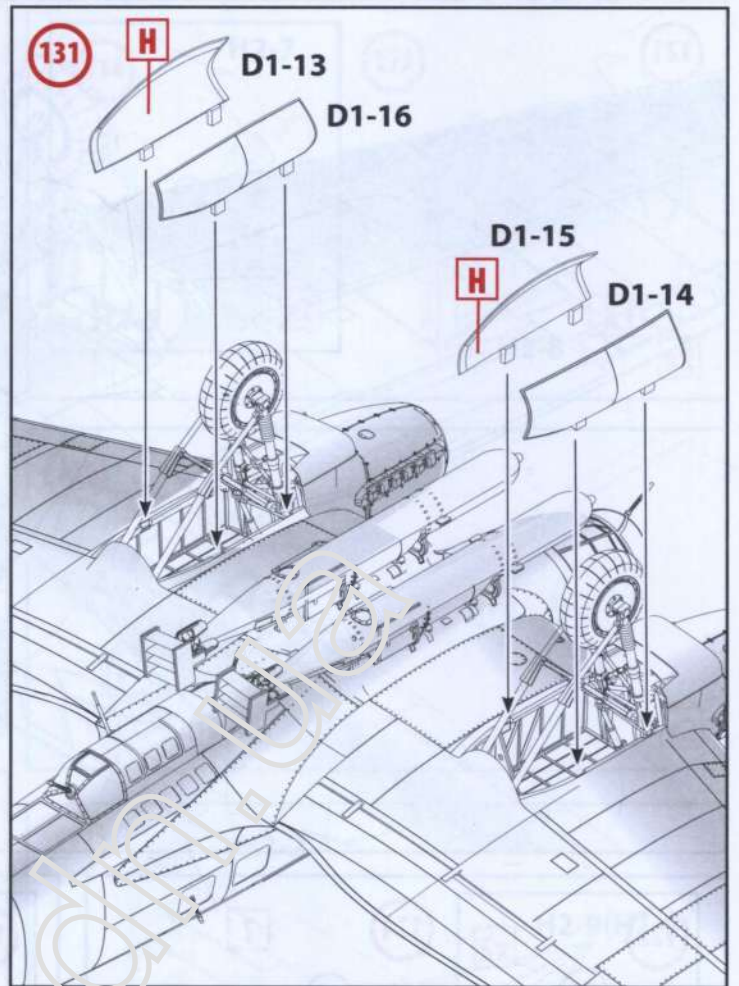
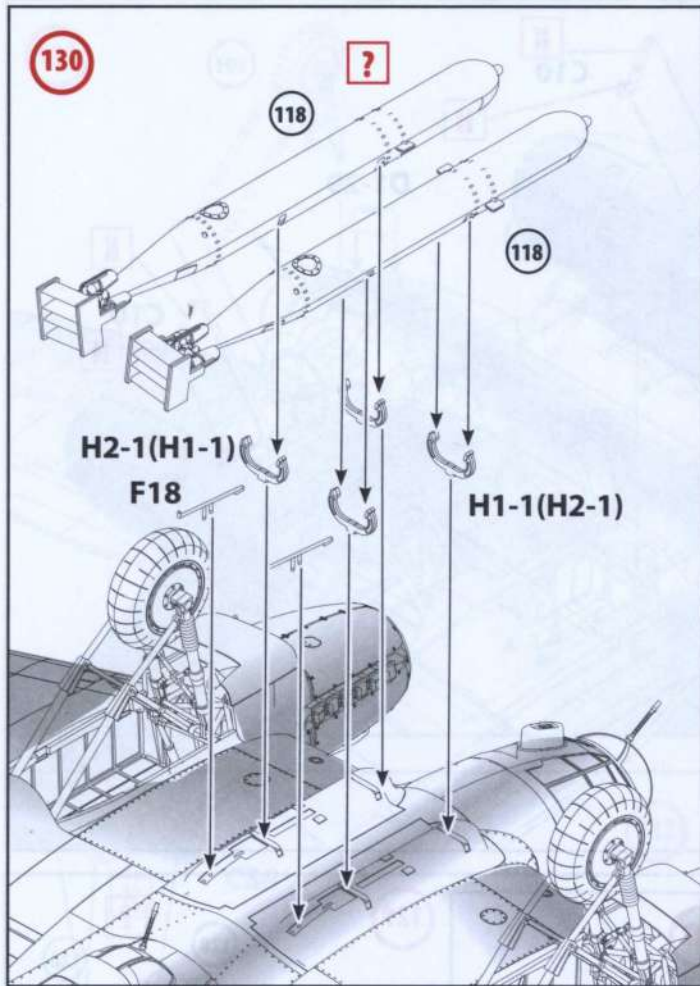



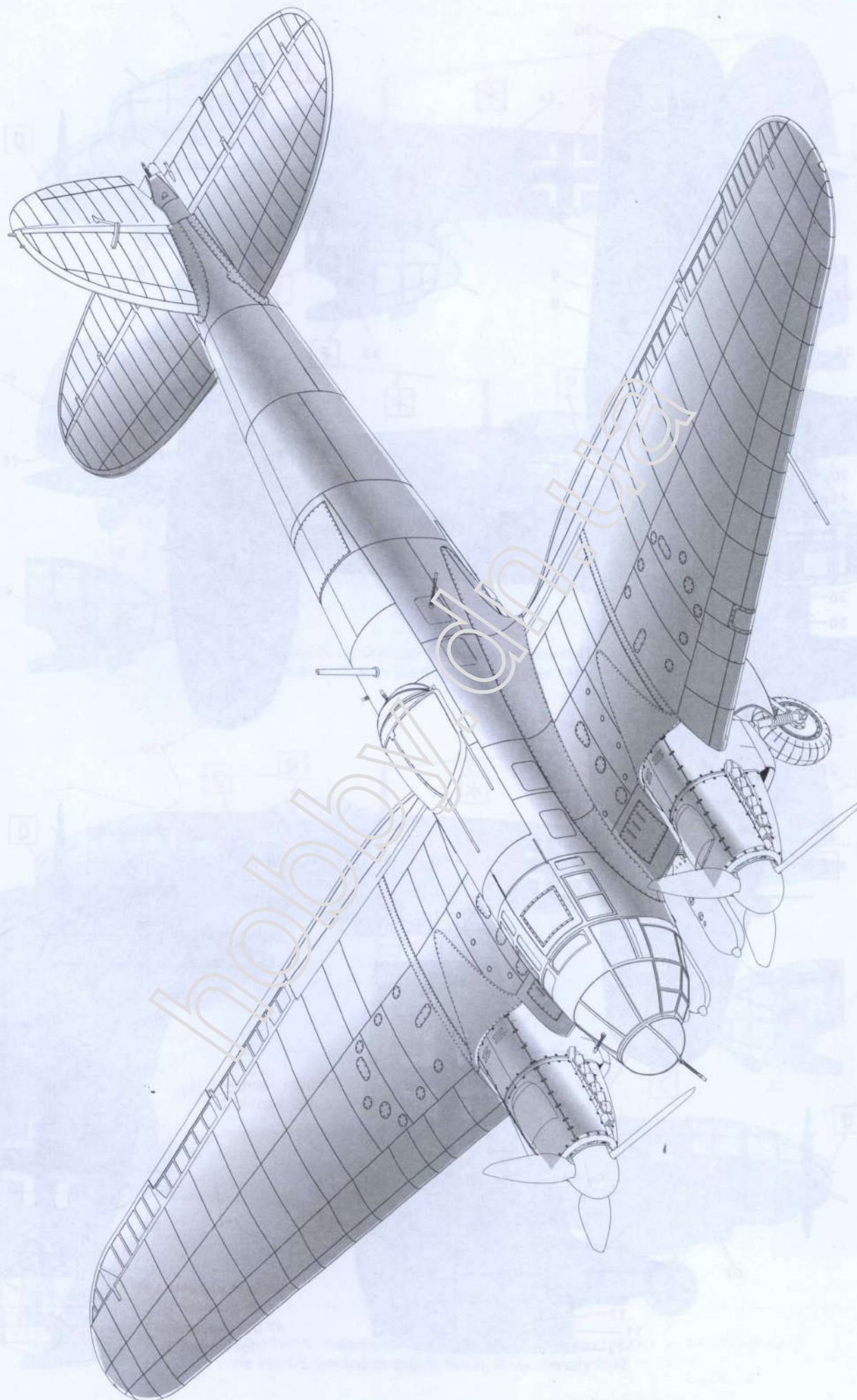

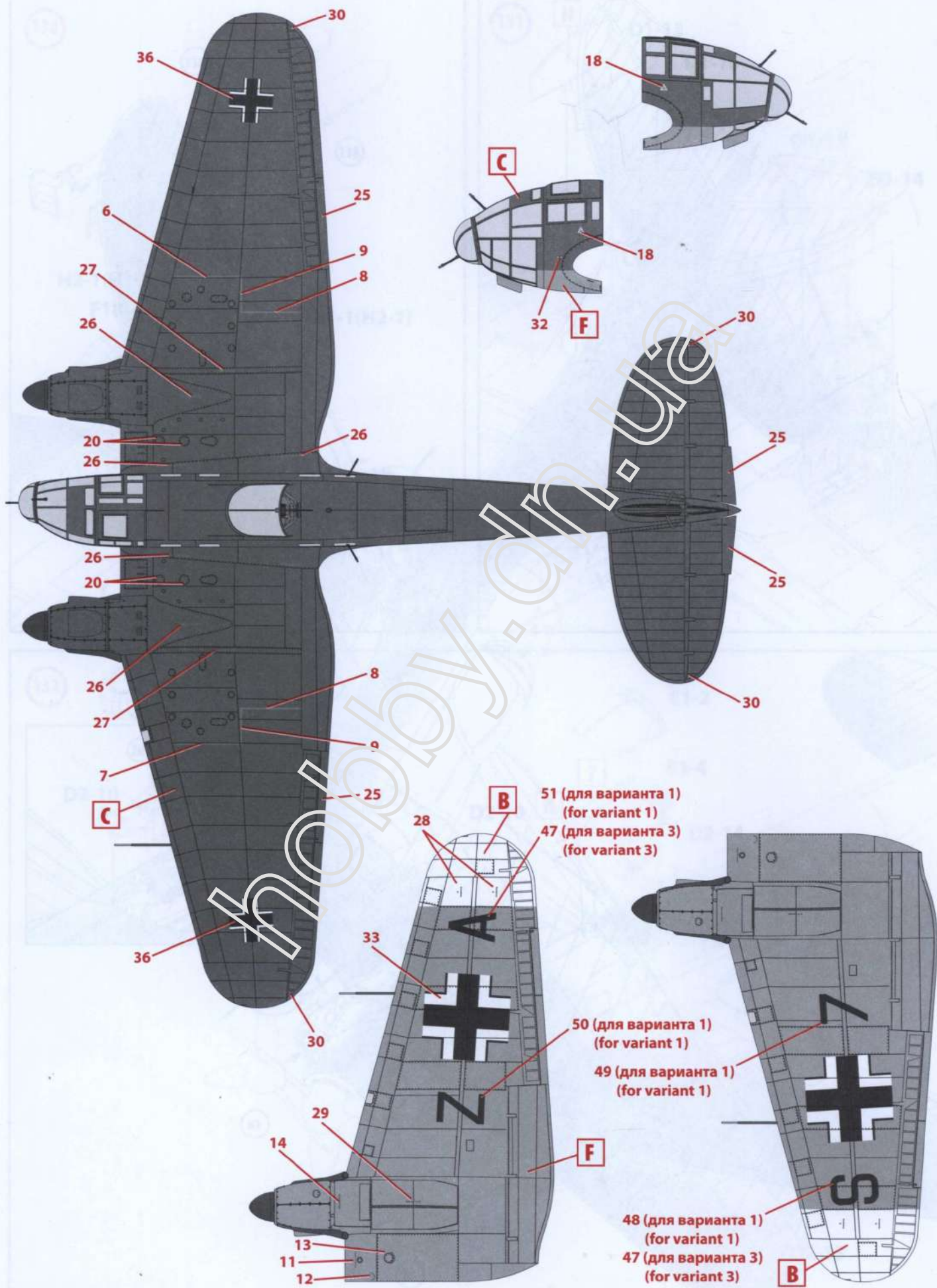

**C**

**C**

**F**

**C**

**B**

51 (для варианта 1)  
 (for variant 1)  
 47 (для варианта 3)  
 (for variant 3)

50 (для варианта 1)  
 (for variant 1)  
 49 (для варианта 1)  
 (for variant 1)

**F**

48 (для варианта 1)  
 (for variant 1)  
 47 (для варианта 3)  
 (for variant 3)

**B**

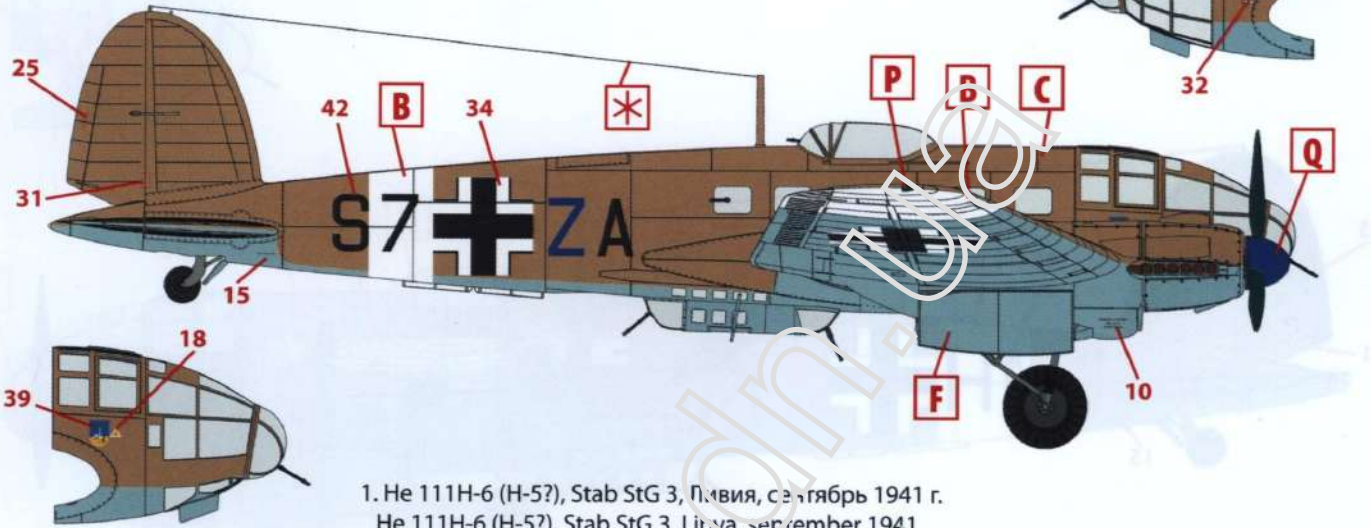
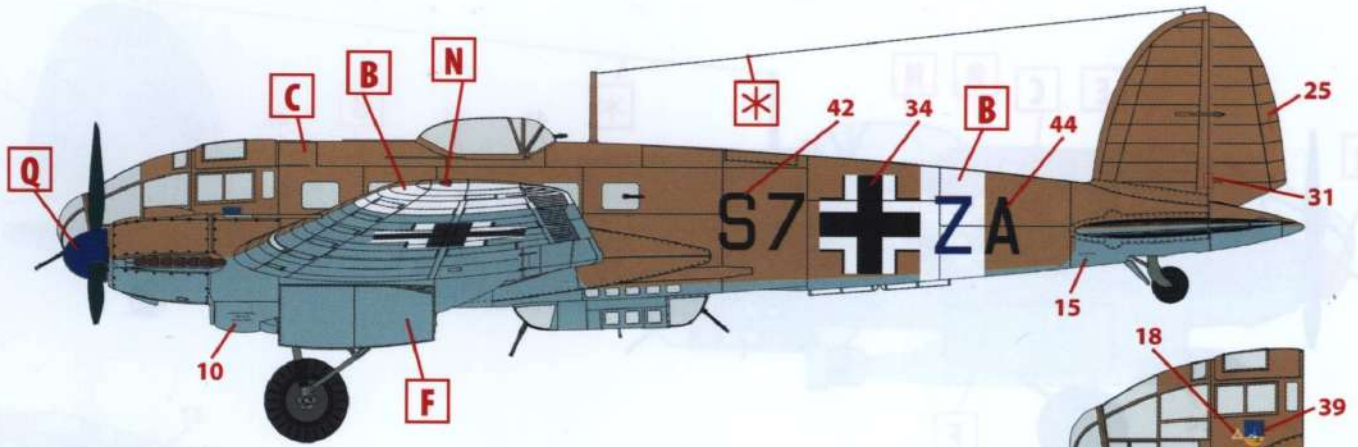

1. He 111H-6 (H-57), Stab StG 3, Италия, сентябрь 1941 г.  
 He 111H-6 (H-57), Stab StG 3, Libya, September 1941

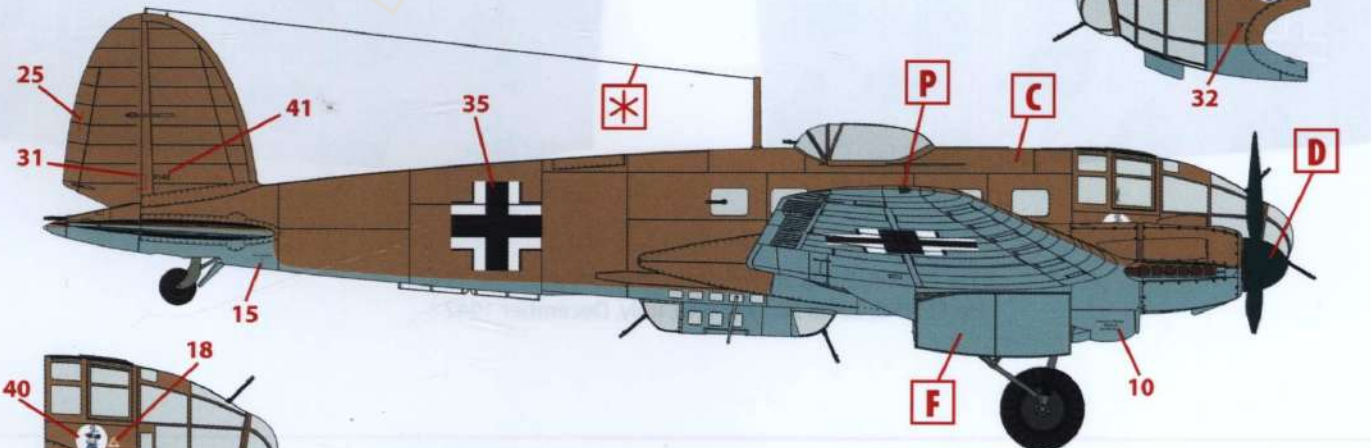
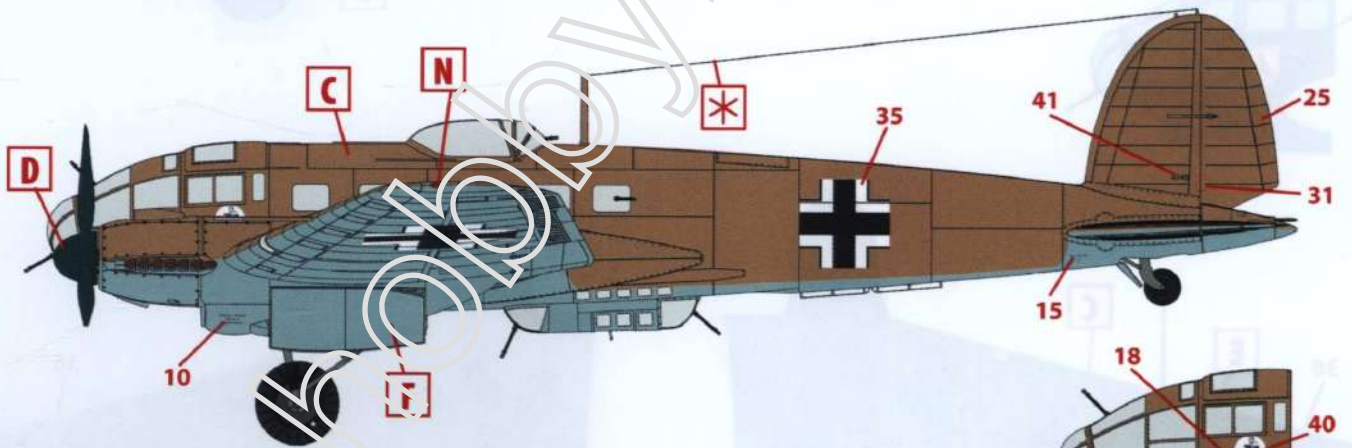

2. He 111H-6, зондеркоманда Блайх, Африка, январь 1942 г.  
 He 111H-6, Sonderkommando Blaich, Africa, January 1942



3. He 111H-6, 2./KG 26, Гроссето, Италия, декабрь 1942 г.  
 He 111H-6, 2./KG 26, Grosseto, Italy, December 1942