



## A-26B Invader Pacific War Theater

**1/48 SCALE MODEL KIT No 48285**

### A-26B «Инвейдер» на Тихоокеанском ТВД Американский бомбардировщик II МВ

Дуглас А-26 «Инвейдер» был лучшим американским двухмоторным бомбардировщиком II Мировой войны. Он имел высокие летные характеристики и мощное вооружение. А-26 производился в 1942-1945 г. Всего было выпущено 1355 самолетов А-26В со «сплошным» носом (6-8 12,7-мм пулеметов Браунинг) и 1091 А-26С с «остекленным».

Бомбардировщики А-26 активно применялись в Западной Европе, Италии и на Тихом океане в 1944-1945 г. До последних дней Второй мировой войны они использовались для атак тылов противника, железных и автомобильных дорог.

#### Тактико-технические характеристики A-26B Invader

Длина, м	15,44
Размах крыла, м	21,34
Нормальный взлетный вес, кг	11793
Двигатель	2x Pratt Уитни R-2800, 2000 л.с.
Максимальная скорость, км/ч	457
Потолок, м	6736
Дальность, км	2253
Вооружение	До 18x12,7-мм пулеметов Браунинг, до 2710 кг бомб

### A-26B Invader Pacific War Theater WWII American Bomber

Douglas A-26 Invader was the best WWII American twin-engine bomber. It had high flight data and carried powerful weapons. It was produced in 1942-1945. There were produced 1355 A-26B aircraft with solid nose (6-8 12,7 mm Browning MG) and 1091 A-26C aircraft with glassed nose.

A-26 bombers had active service in the Western Europe, Italy and Pacific in 1944-1945. They were used to the last day of this WWII for attack on the enemy's rear lines, railways and highways.

#### Tactical and Technical Specifications of A-26B Invader

Length, m	15,44
Span, m	21,34
Start Weight, kg	11793
Engine	2x Pratt Whitney R-2800, 2000 hp
Max. Speed, km/h	457
Service ceiling, m	6736
Range, km	2253
Armament	Up to 18x12,7 mm Browning MG, bomb load - up to 2710 kg

#### ИСПОЛЗУЕМЫЕ КРАСКИ / USED COLORS:

COLOR	Revell	Tamiya
<b>A</b> Оливковый, матовый   Olive Drab	142	XF62
<b>B</b> Черный, полуматовый   Semigloss Black	202	X18
<b>C</b> Алюминий   Aluminium	199	XF16
<b>D</b> Желтый, матовый   Flat Yellow	115	XF3
<b>E</b> Синий, матовый   Flat Blue	156	XF8
<b>F</b> Серый, матовый   Flat Grey	143	XF20
<b>G</b> Зеленый, матовый   Flat Green	360	XF5
<b>H</b> Серебристый   Chrome Silver	190	X11

COLOR	Revell	Tamiya
<b>J</b> Сталь   Steel	191	X32
<b>K</b> Темный металл   Gun Metal	109	X10
<b>L</b> Черный, матовый   Flat Black	108	XF1
<b>M</b> Красный, прозрачный   Clear Red	731	X27
<b>N</b> Зеленый, прозрачный   Clear Green	161	X25
<b>P</b> Светло-зеленый   Leaf Green	364	X28
<b>Q</b> Светло-оливковый   Light Olive	186	XF49

**01** СТАДИЯ СБОРКИ  
ASSEMBLY STEP

**03** СБОРОЧНАЯ ЕДИНИЦА  
ASSEMBLY UNIT

**■** ПРИ СБОРКЕ НЕ ИСПОЛЗУЕТСЯ  
PARTS NOT FOR USE

**✖** НЕ КЛЕИТЬ  
DO NOT CEMENT

**⚡** ПРОСВЕРЛИТЬ  
OPEN HOLE

**?** ПРОИЗВОЛЬНЫЙ ВЫБОР  
OPTIONAL

**A** ИСПОЛЗУЕМАЯ КРАСКА  
USED COLOR

**x2** СДЕЛАТЬ ДВЕ ДЕТАЛИ  
MAKE 2 PCS

**\*** СДЕЛАТЬ САМОМУ  
SCRATCH BUILD

**В Н И М А Н И Е !**  
Перед сборкой внимательно прочитать руководство по монтажу. Каждая деталь пронумерована. Соблюдать последовательность монтажа. Необходимые рабочие инструменты: нож и напильник для зачистки деталей; резиновая лента, клейкая лента и зажимы для фиксации склеиваемых деталей. Детали из пластика очистить в растворе мягкого моющего средства и высушить на воздухе для того, чтобы краска и переводные картинки лучше прилипали. Перед приклеиванием проверить, подходят ли детали; клей наносить экономно. Хром и краску удалить с поверхностей склеивания. Небольшие детали покрасить перед тем, как они будут удалены из рамок. Краску необходимо хорошо просушить, только после этого продолжать сборку. Каждую соответствующую переводную картинку отдельно вырезать и примерно на 20 секунд окунуть в теплую воду. На обозначенном месте картинку отделить от бумаги и прижать промокающей бумагой.

**С А У Т И О Н !**  
Read the instructions thoroughly prior to assembly. Each component is numbered. Adhere to specified sequence of assembly. Tools required: knife and file for removal of components from frame; rubber bond, adhesive tape and clothes pegs for clamping components together after applying adhesive. Clean plastic components in a mild detergent solution and allow to air-dry so that paint and transfers adhere better. Prior to applying adhesive, check to see whether the components fit together; apply adhesive sparingly. Remove chrome and paint from the contact surfaces. Paint small components before removing them from the frame. Allow paint to dry well, and only then continue to assemble. Cut out each transfer individually and immerse in warm water for approx. 20 seconds. Slide transfer off paper and into designated position, then press on with blotting paper.

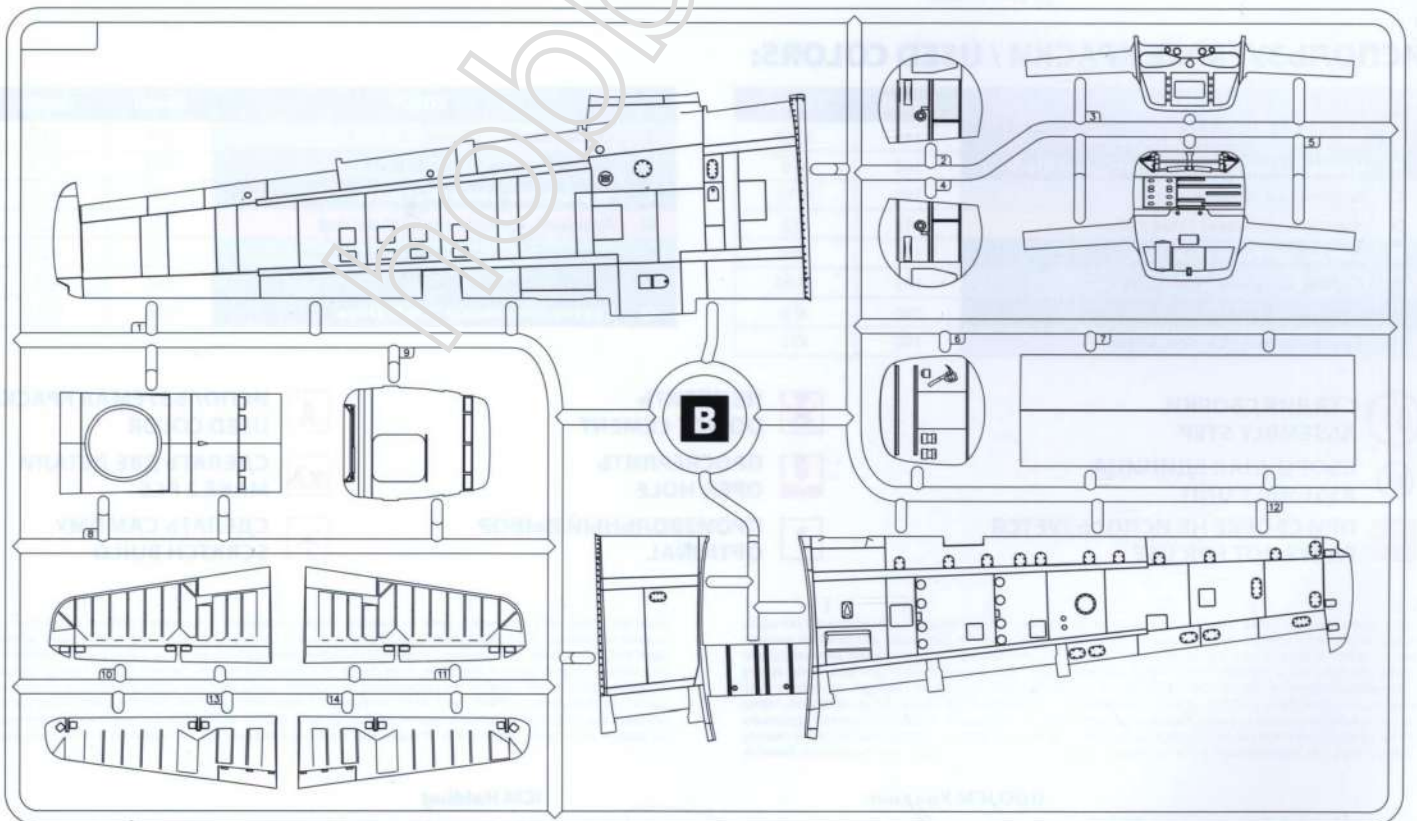
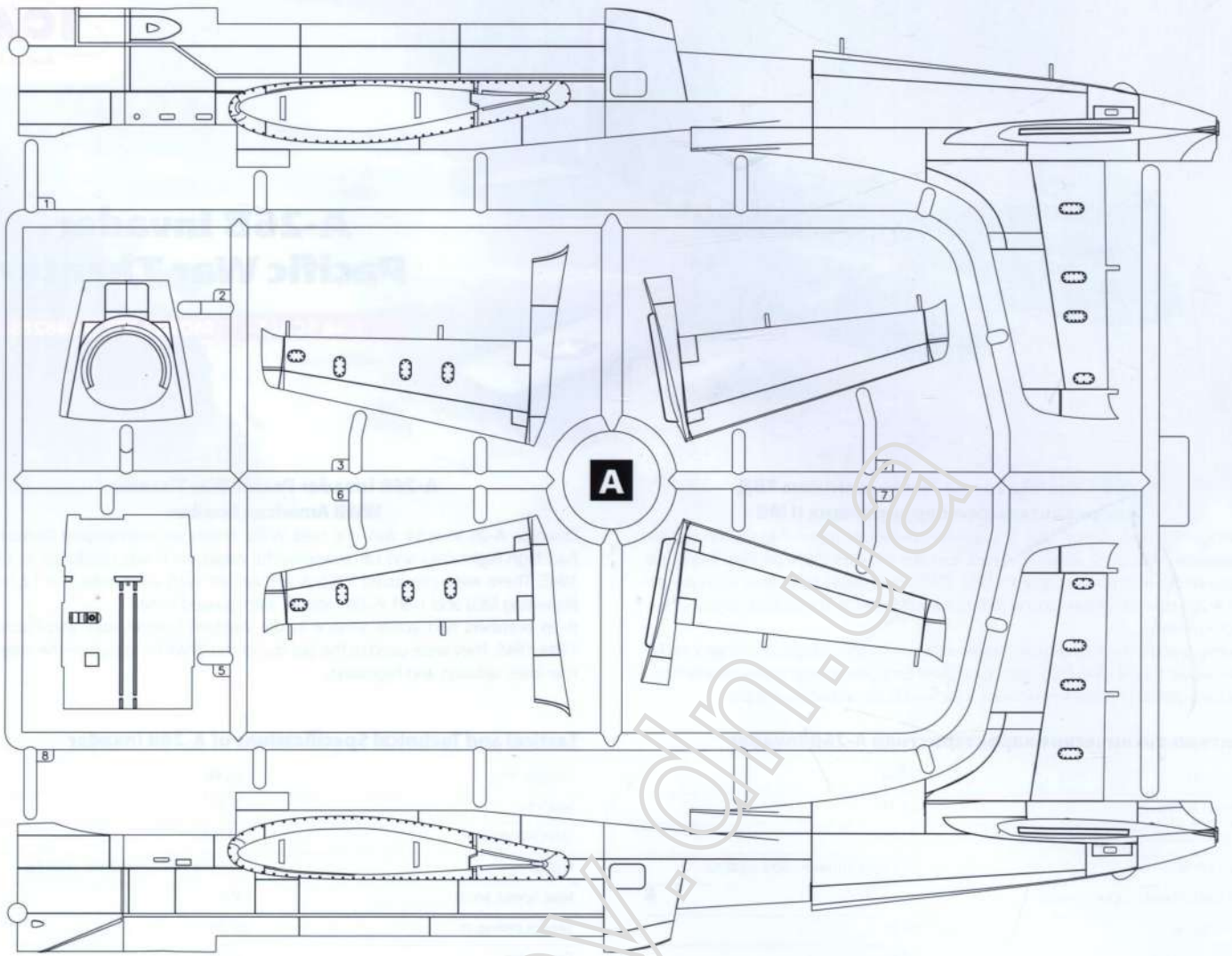

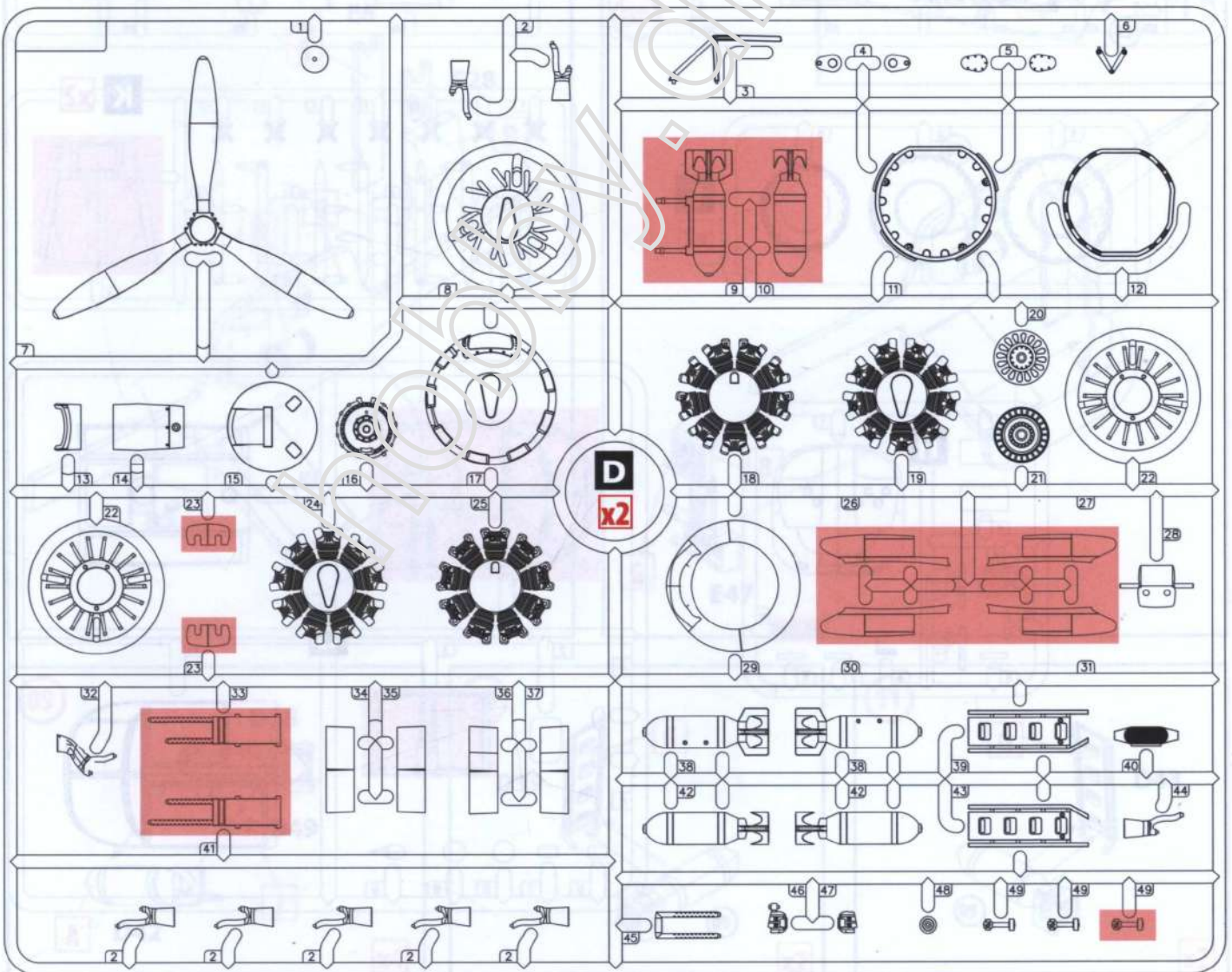
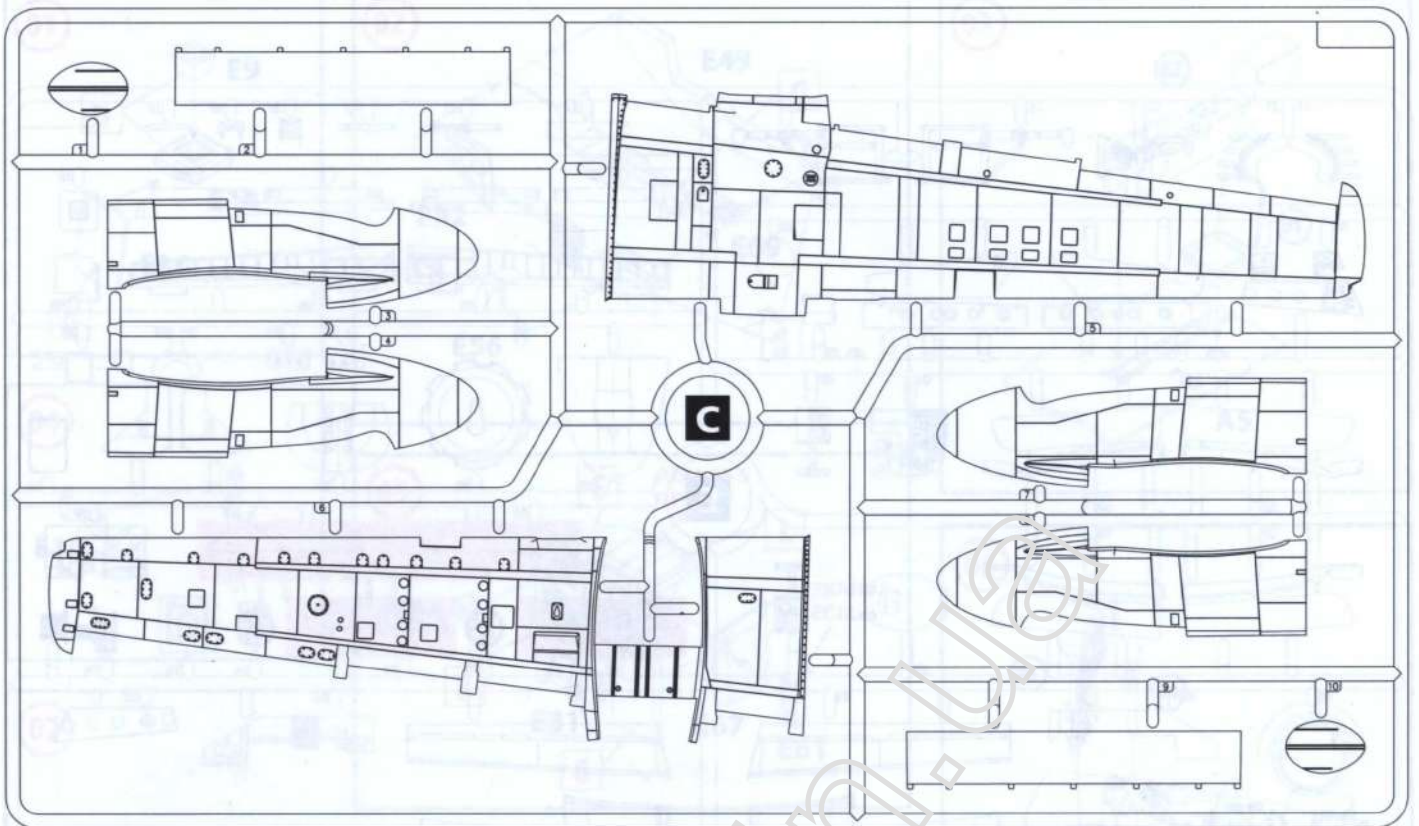

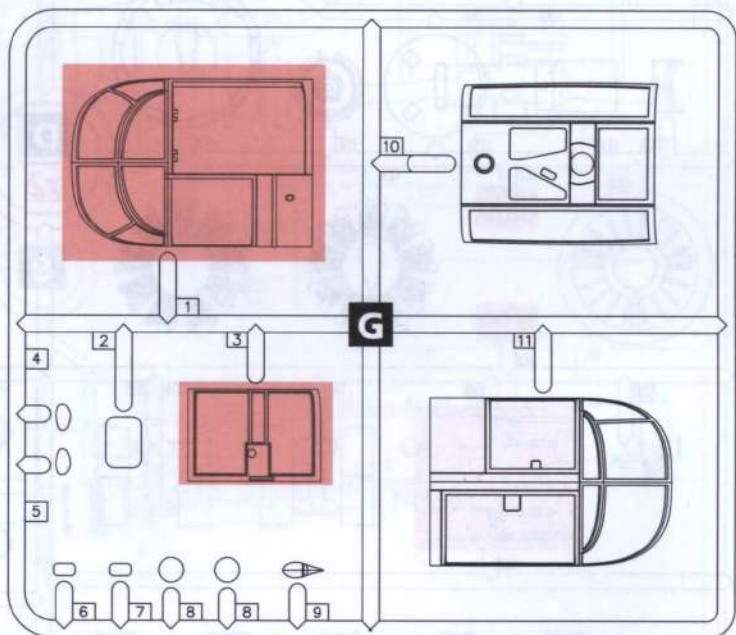
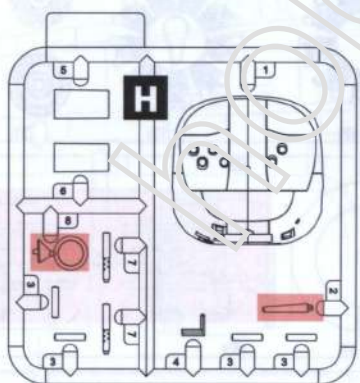
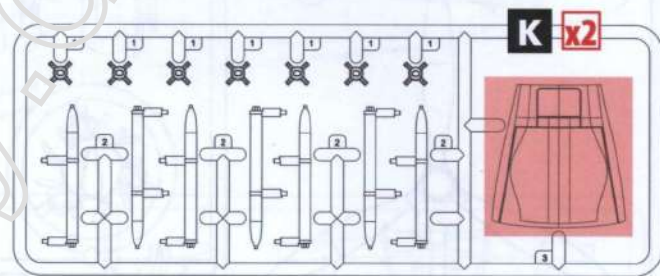
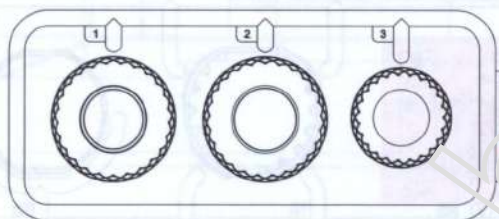
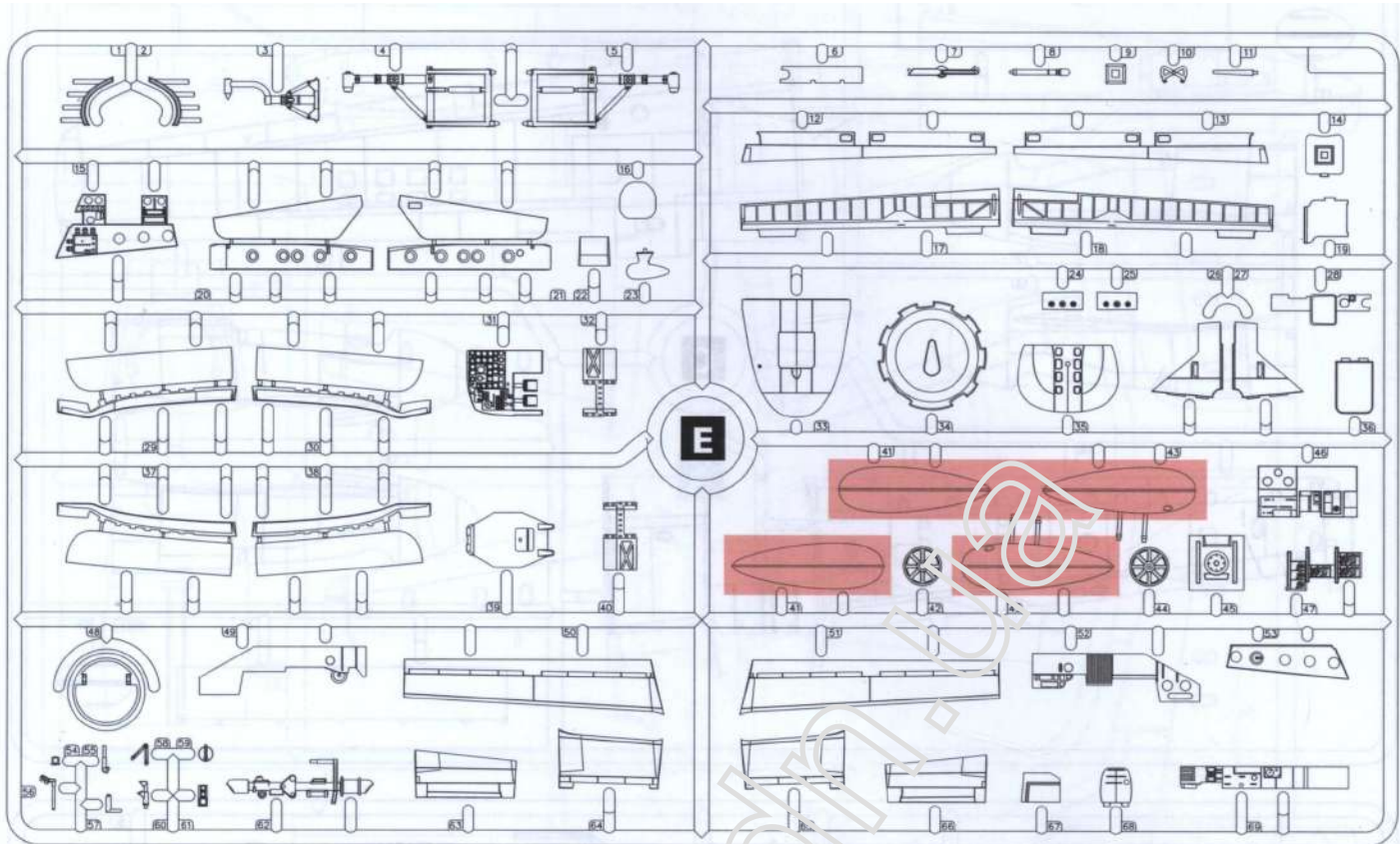

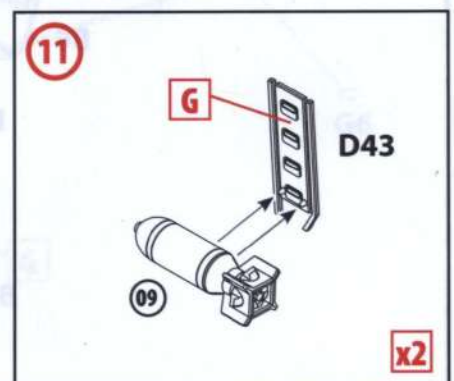
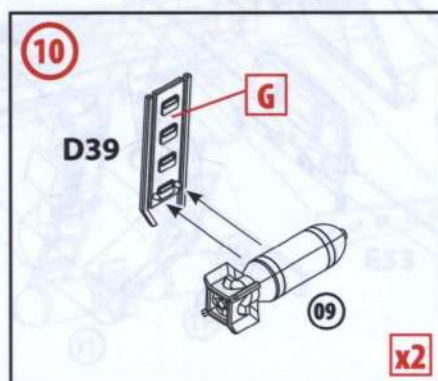
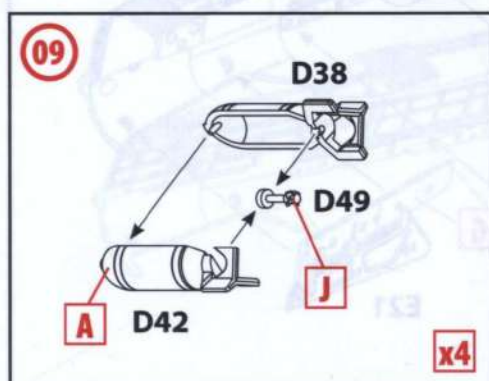
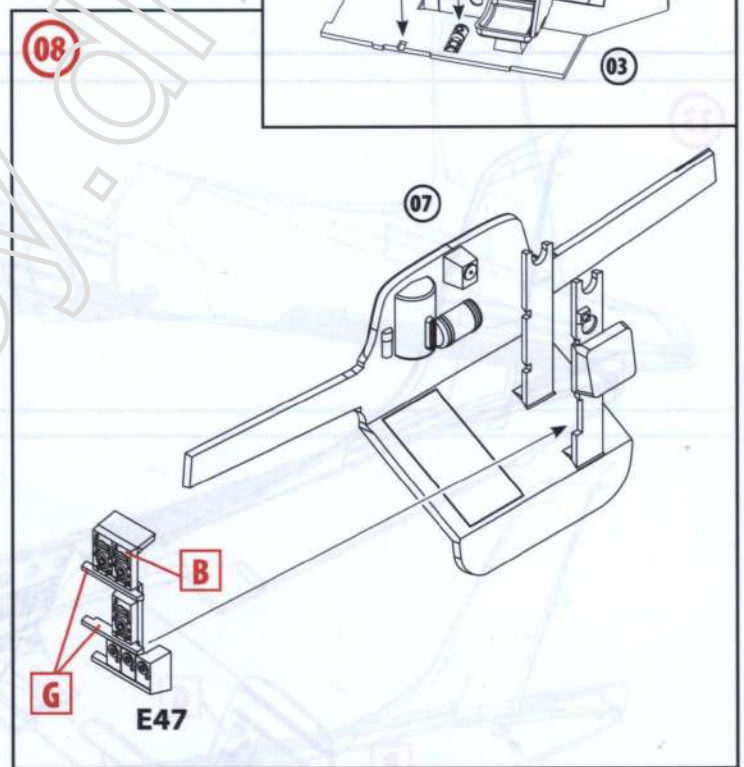
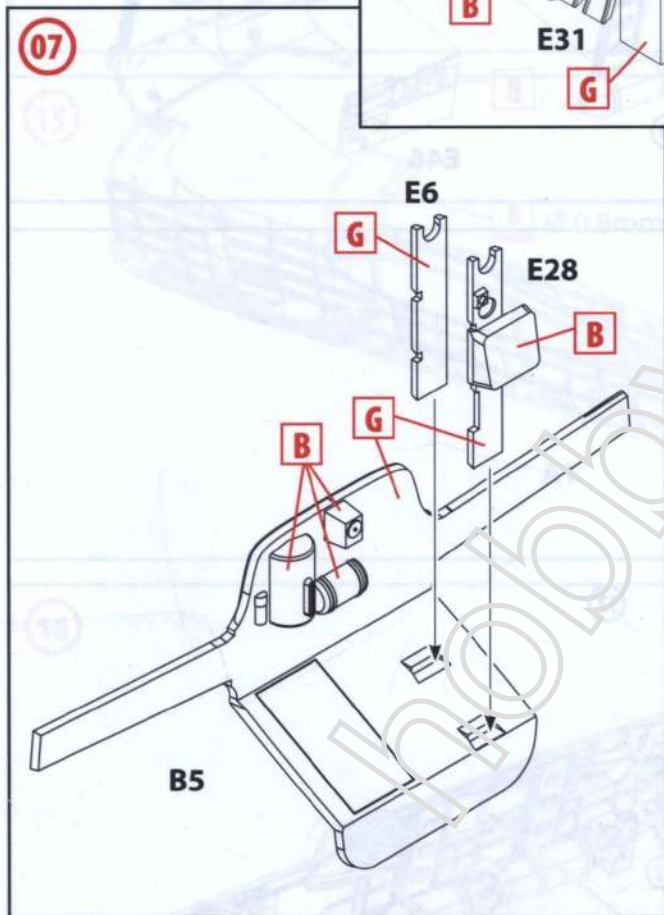
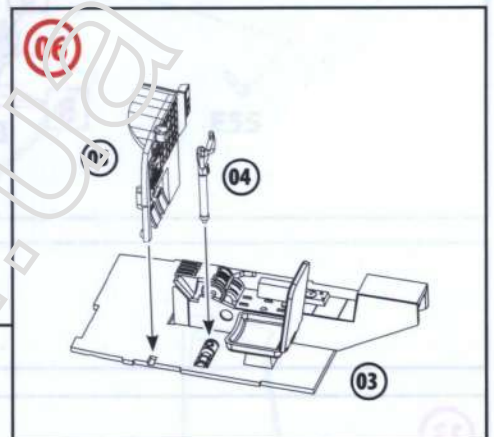
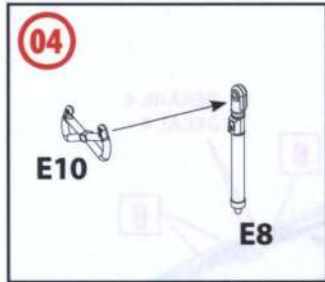
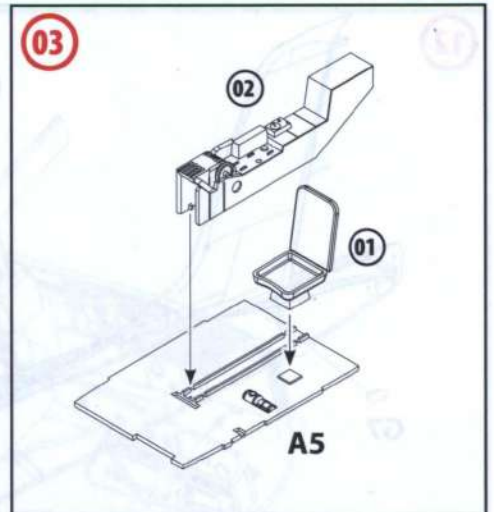
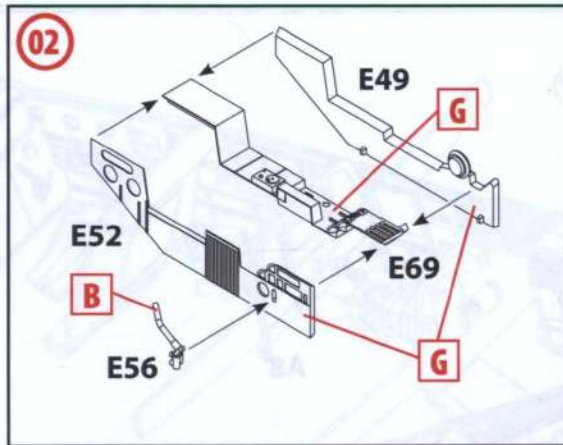
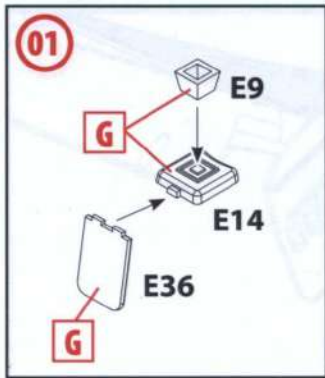

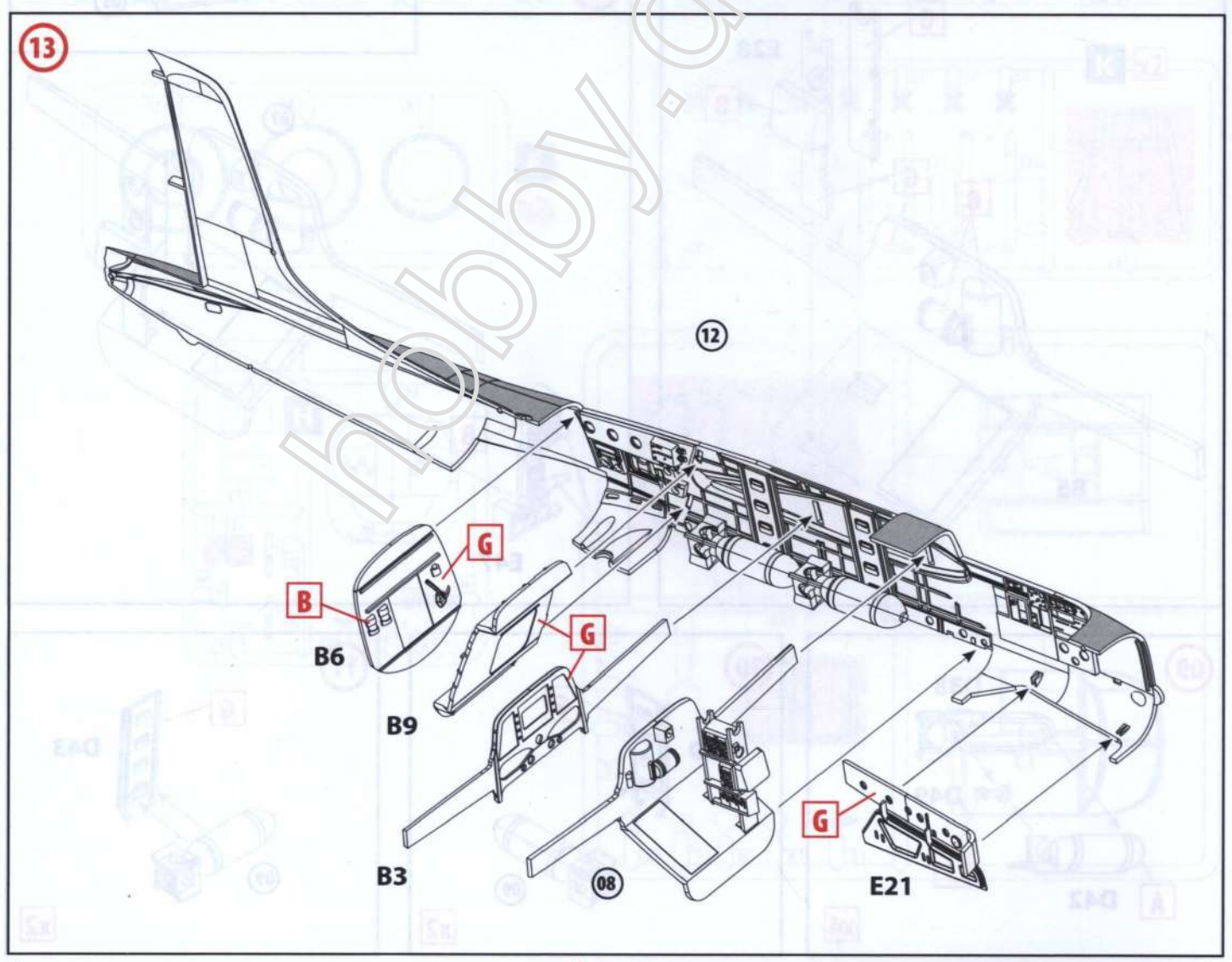
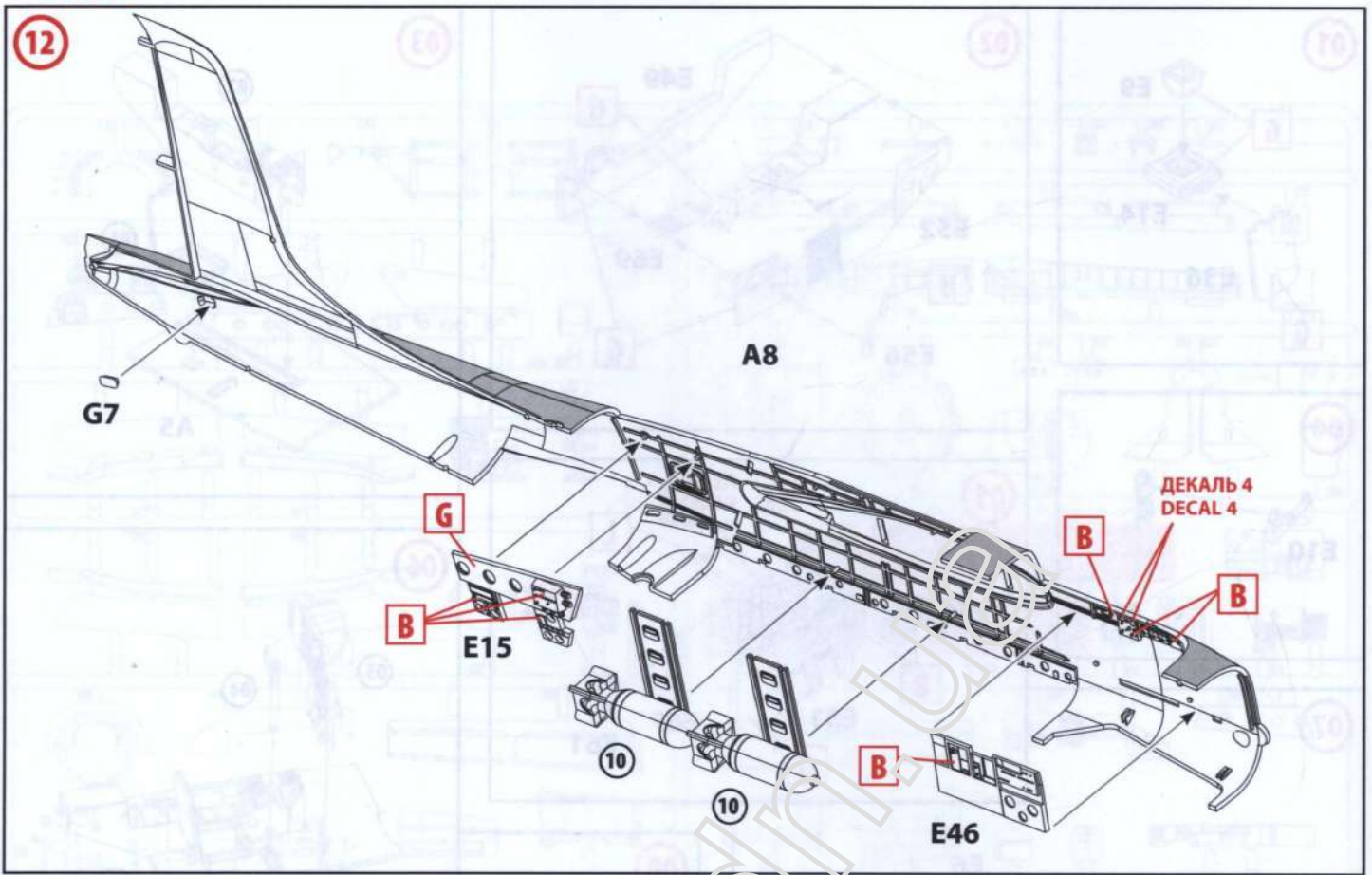

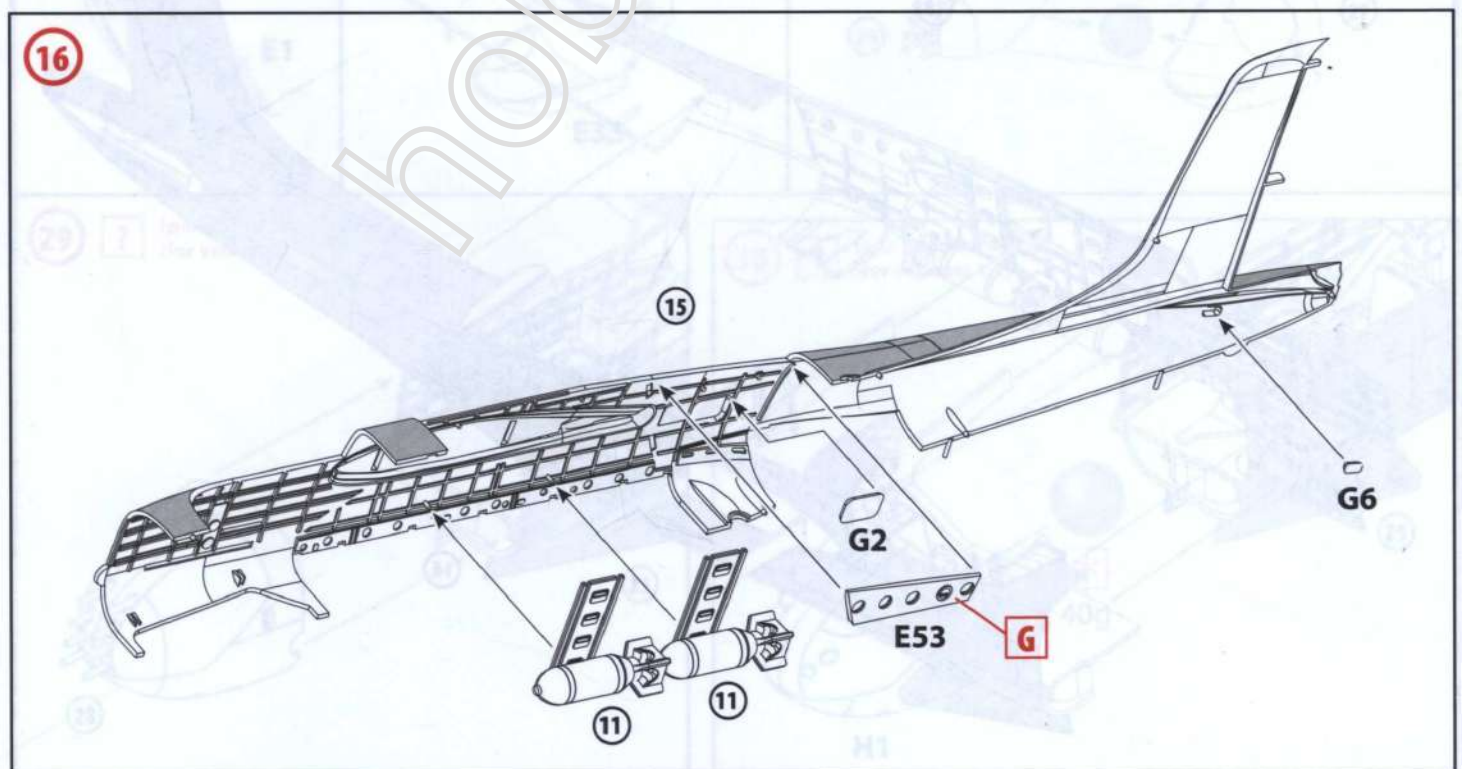
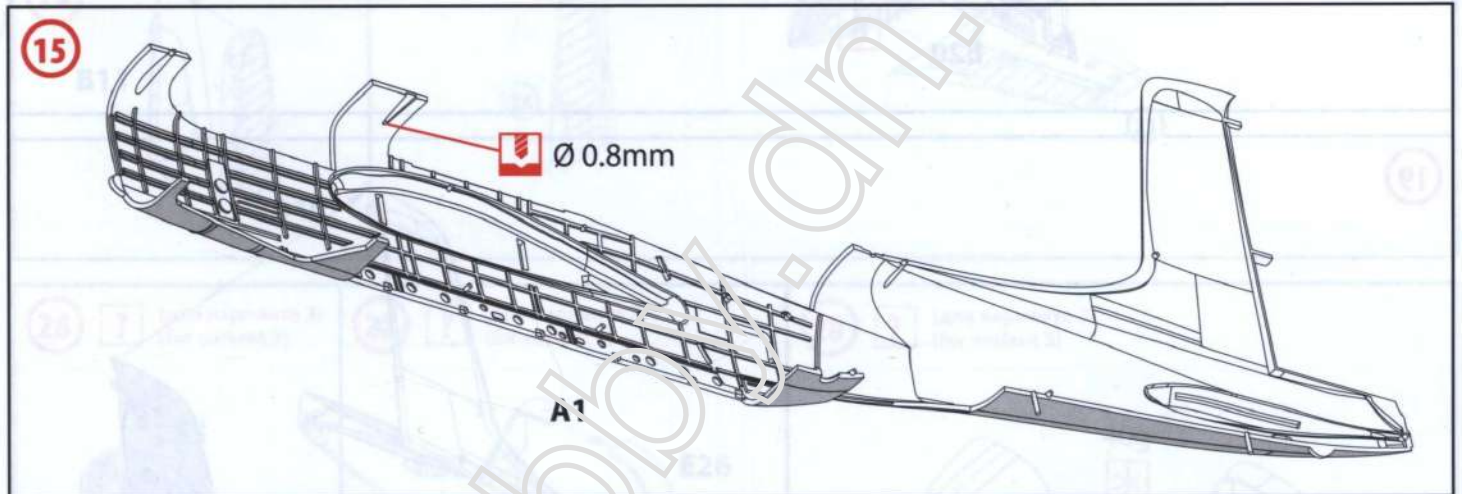
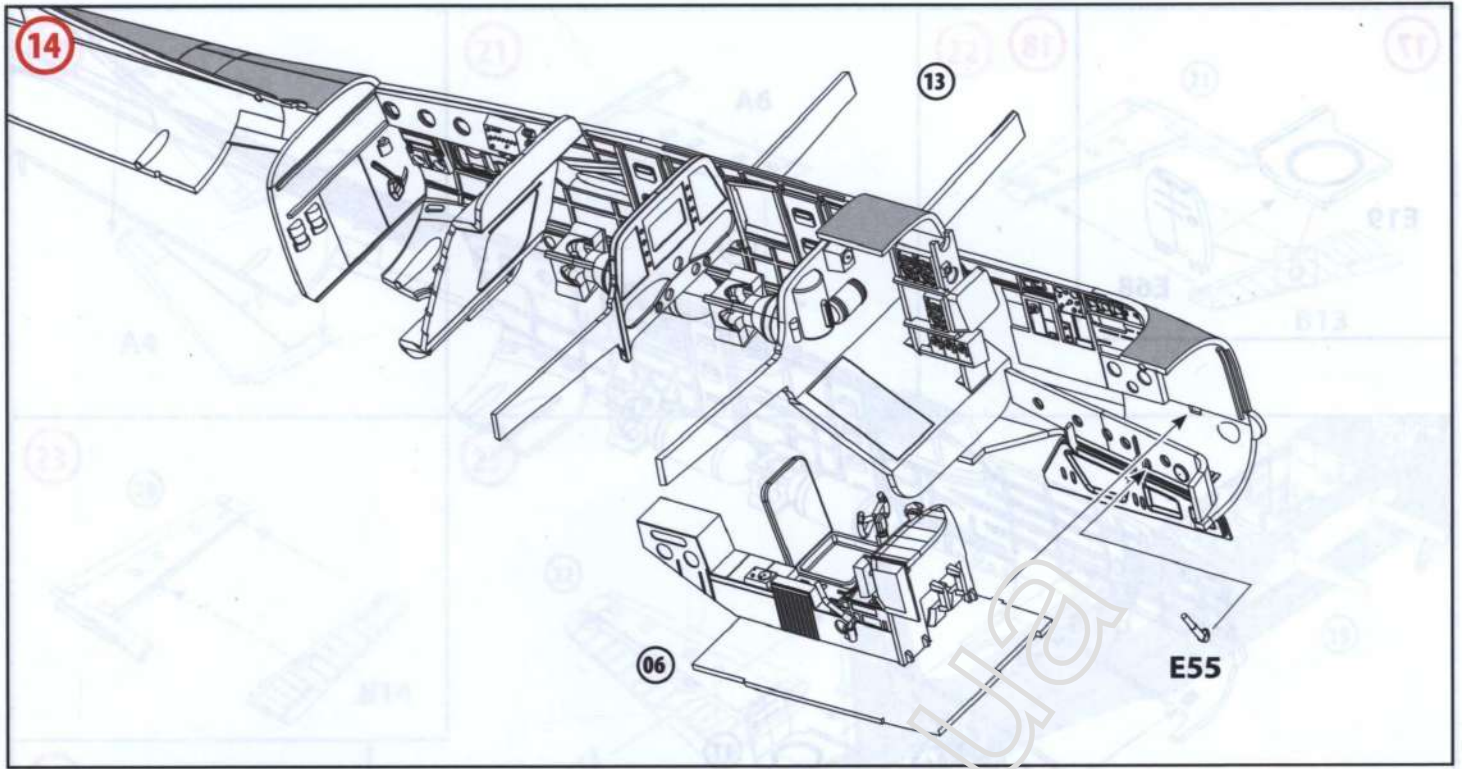

17

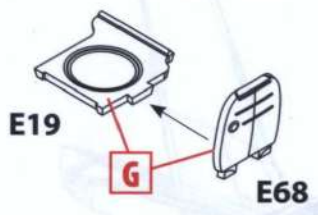

18

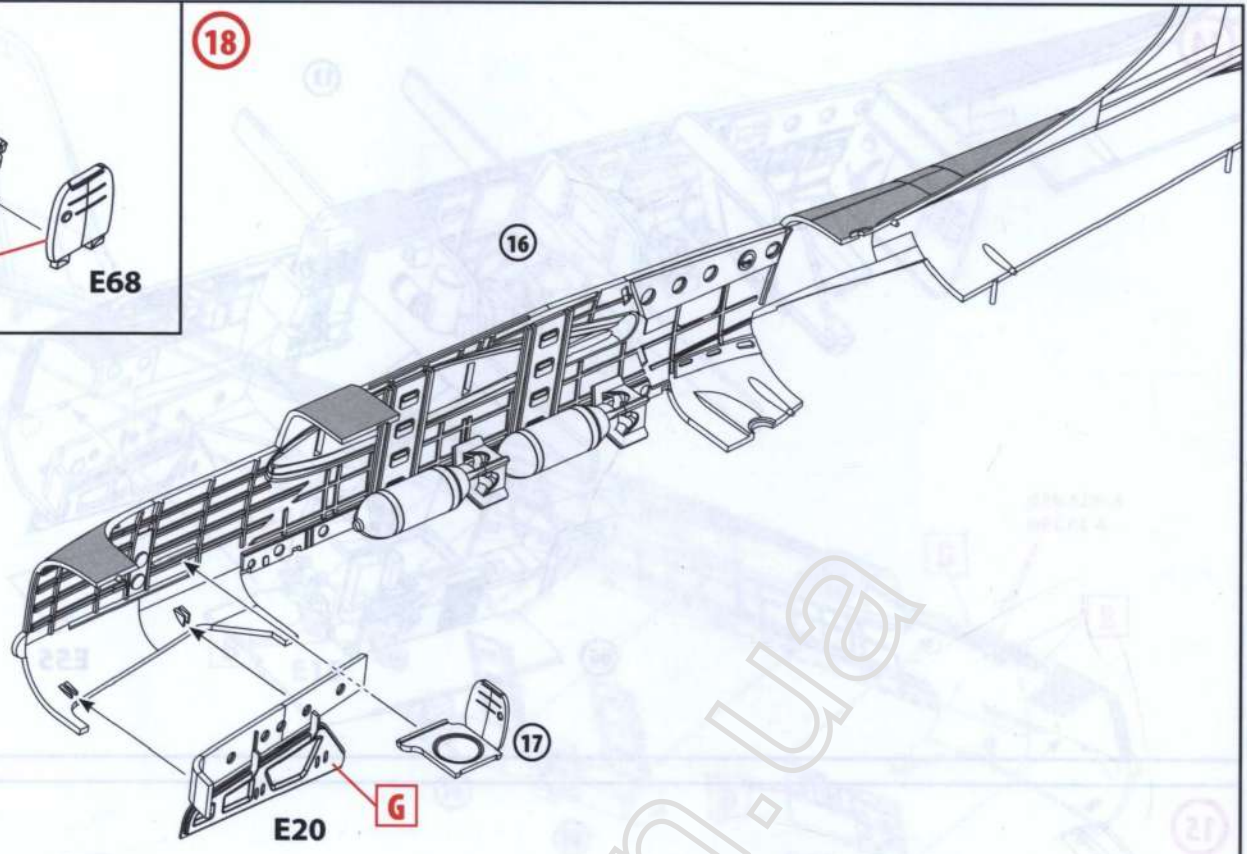

19

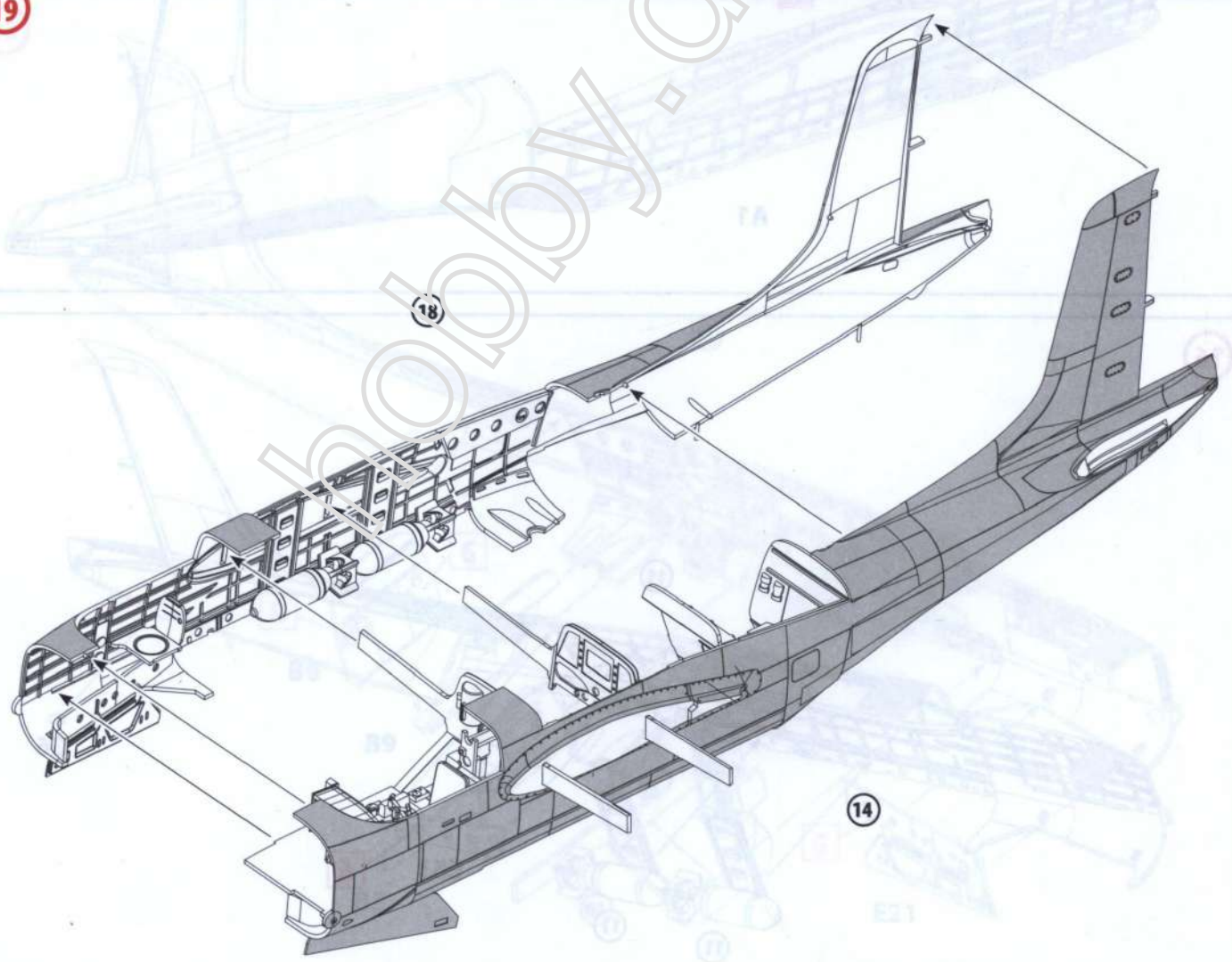



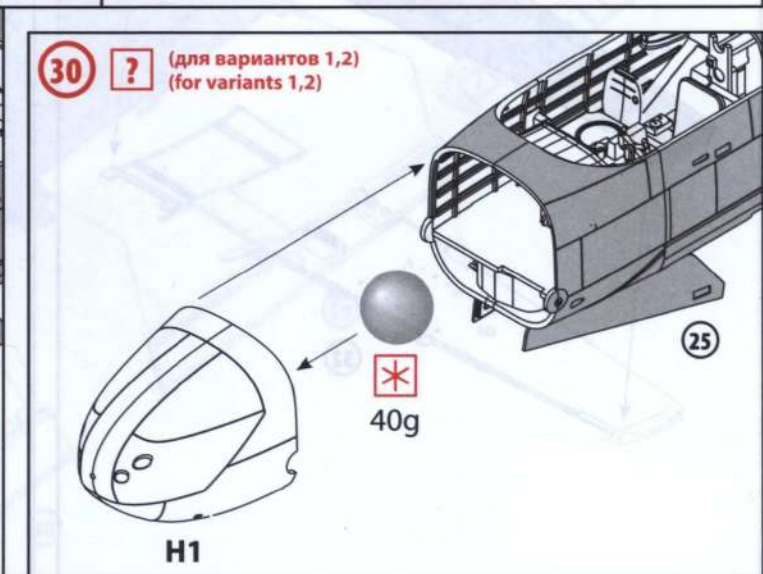
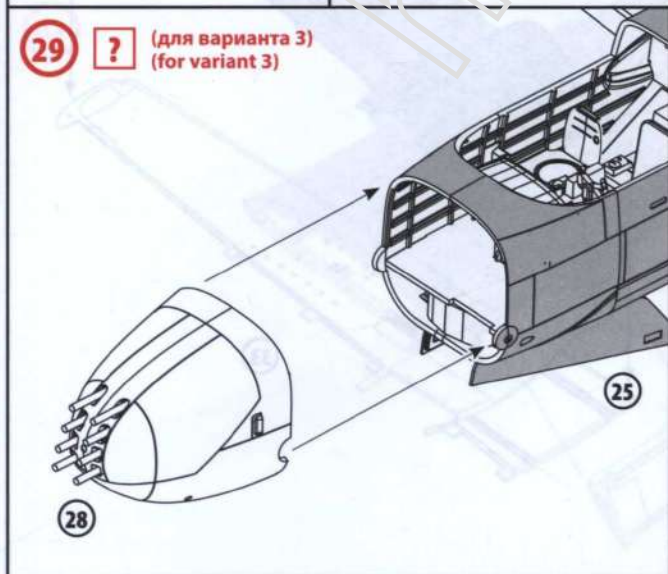
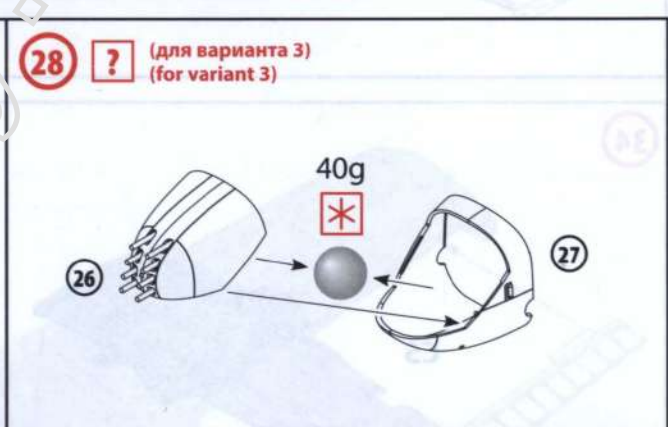
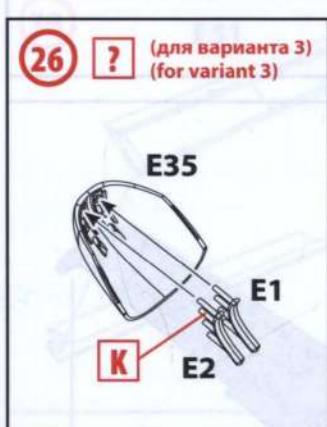
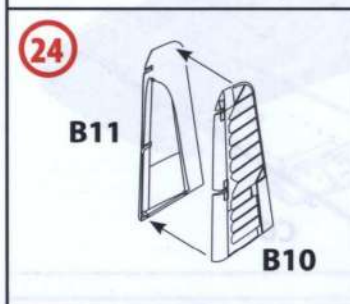
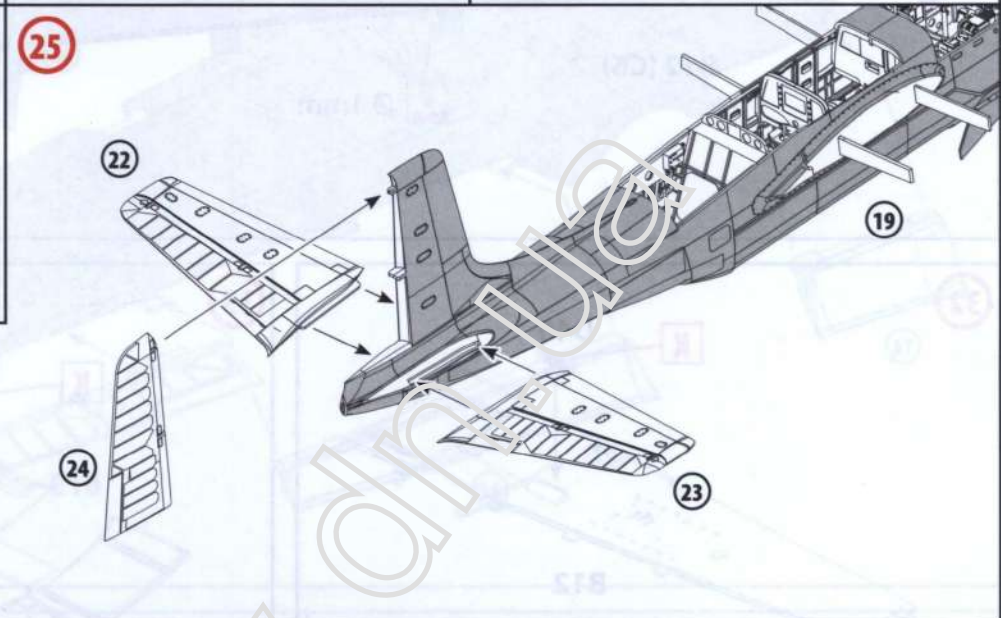
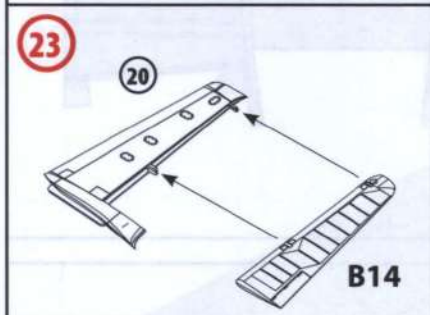
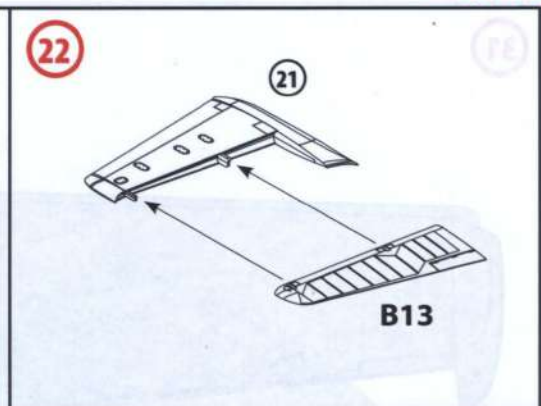
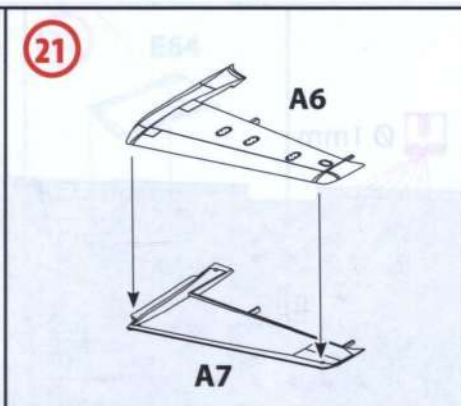
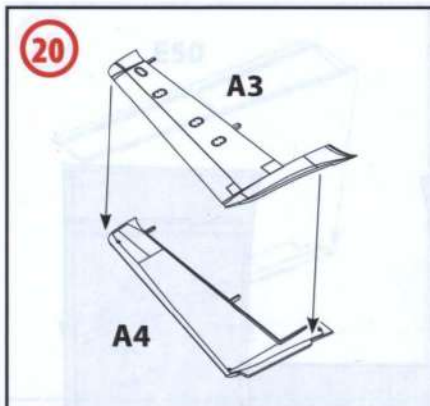

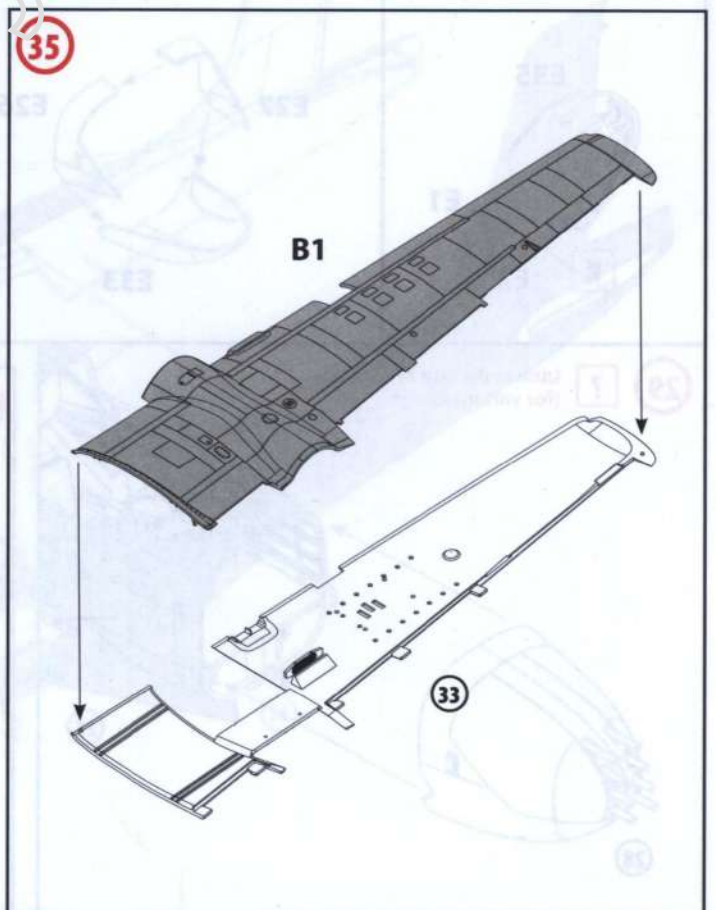
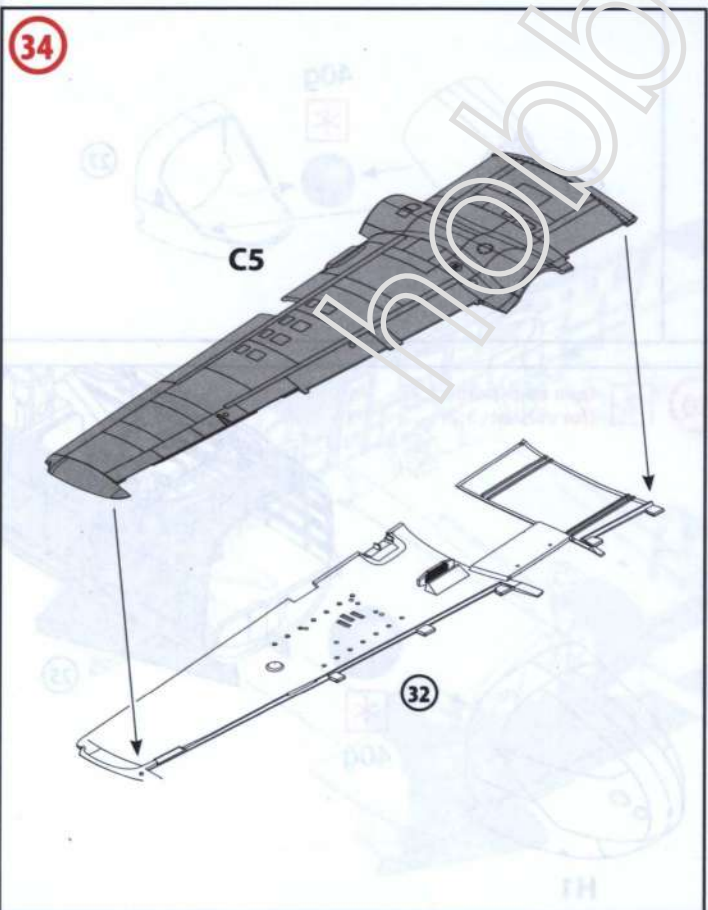
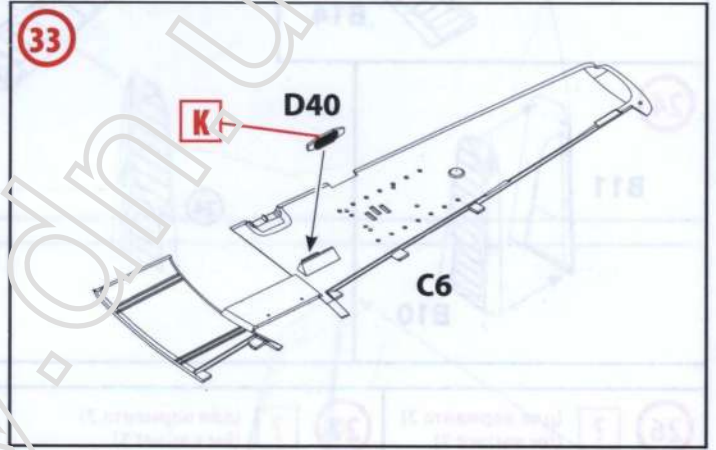
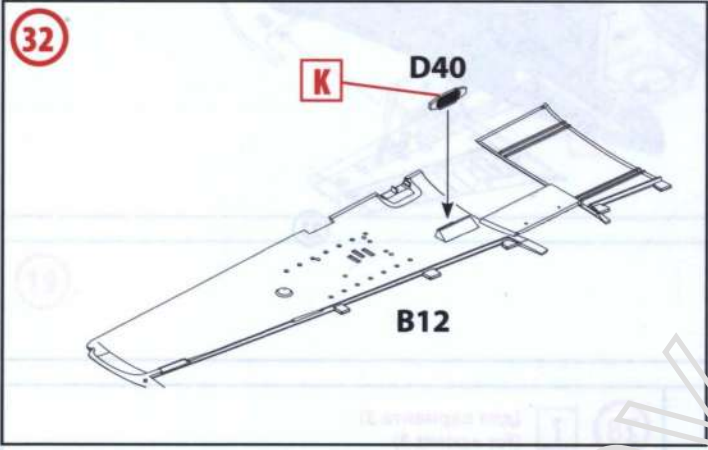
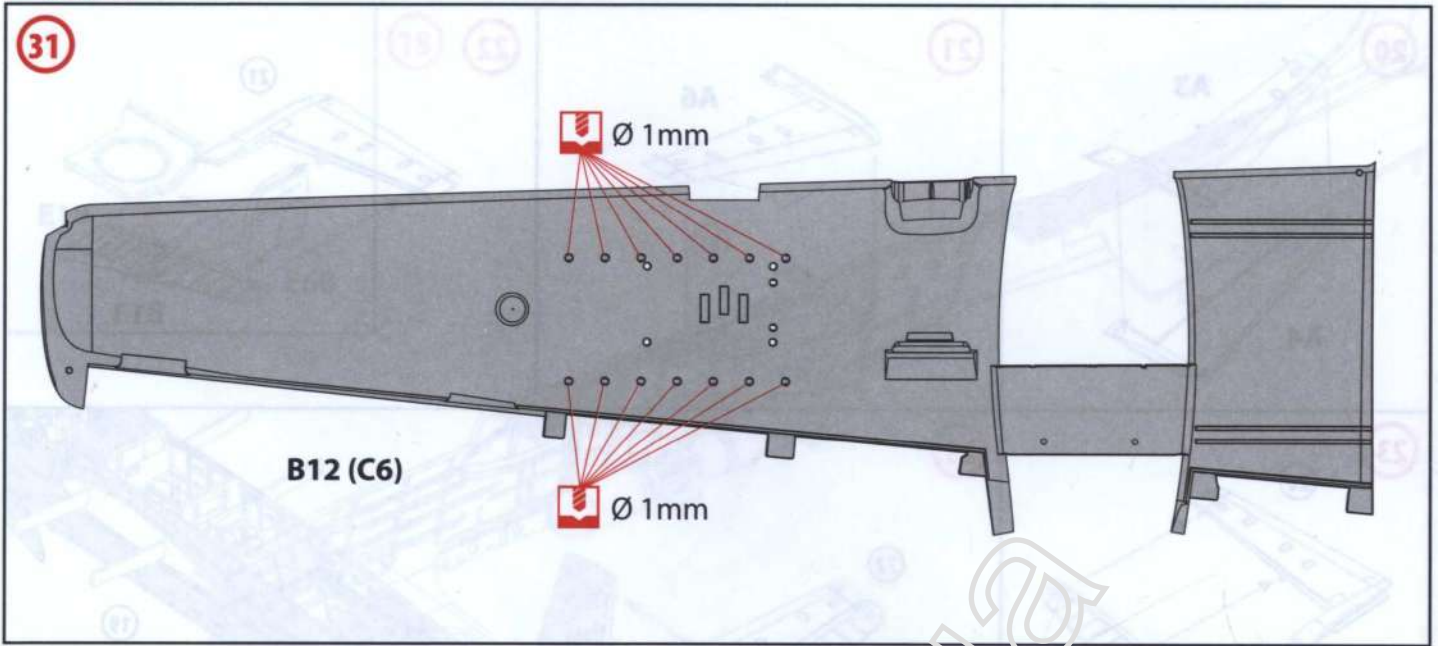

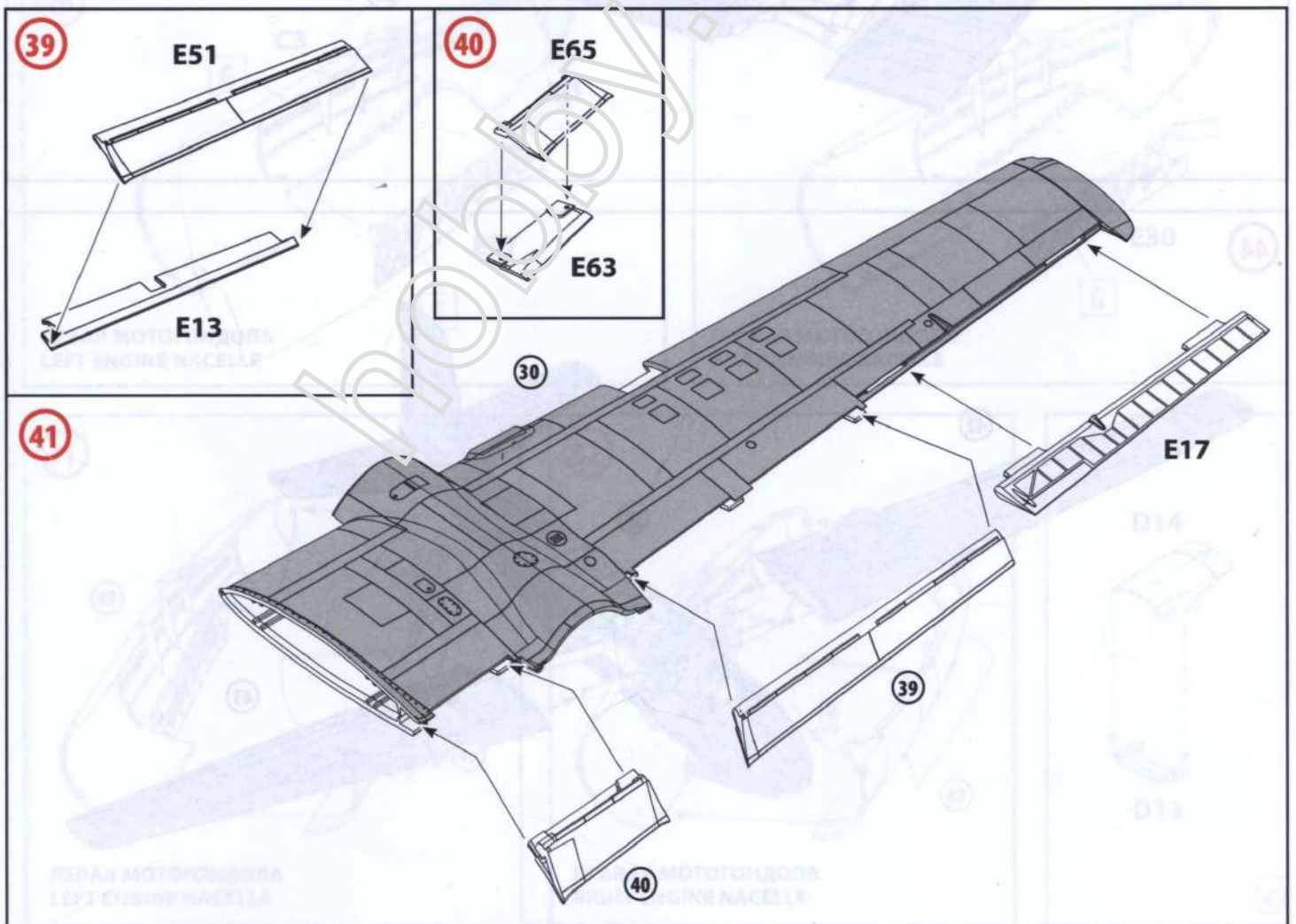
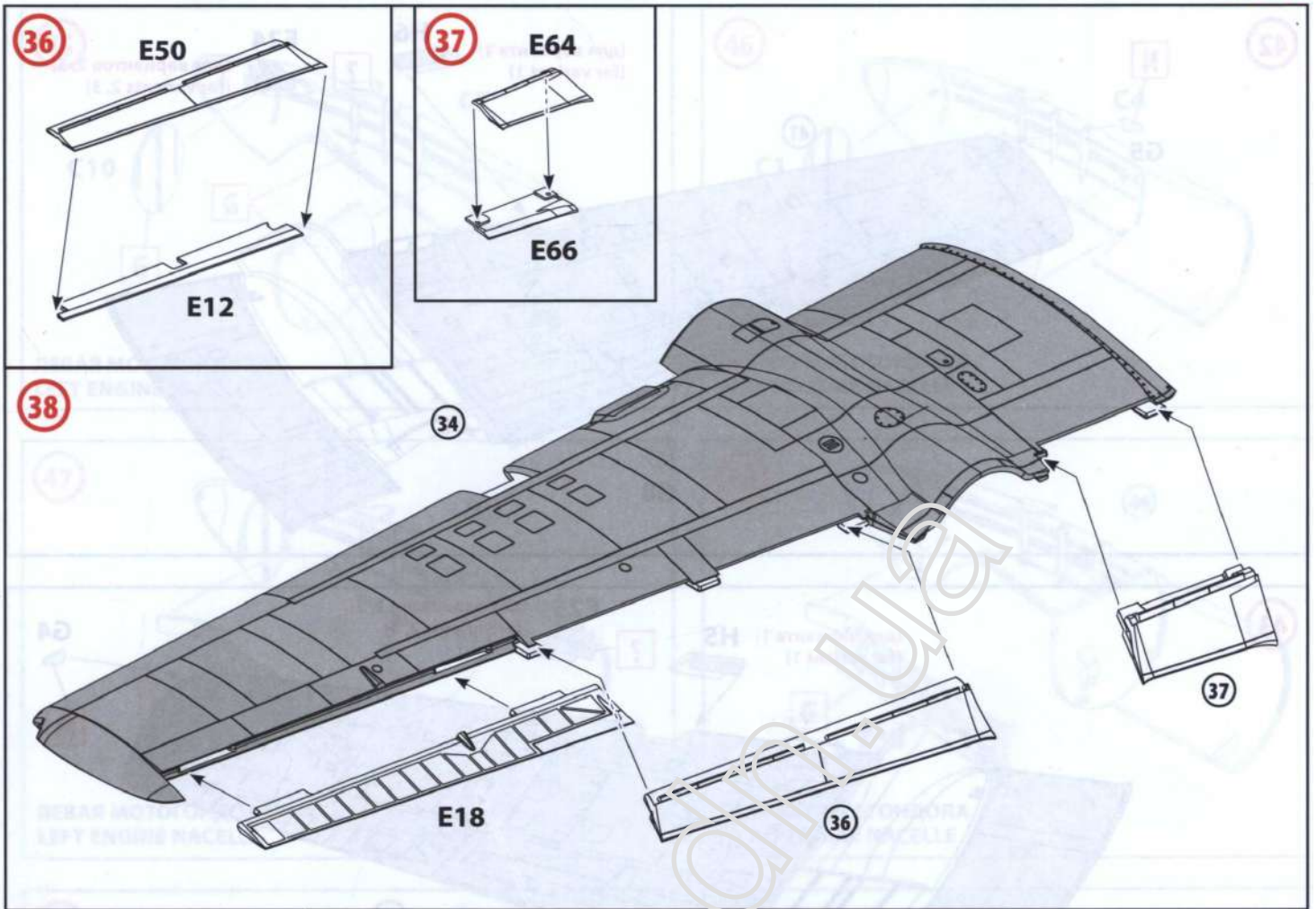

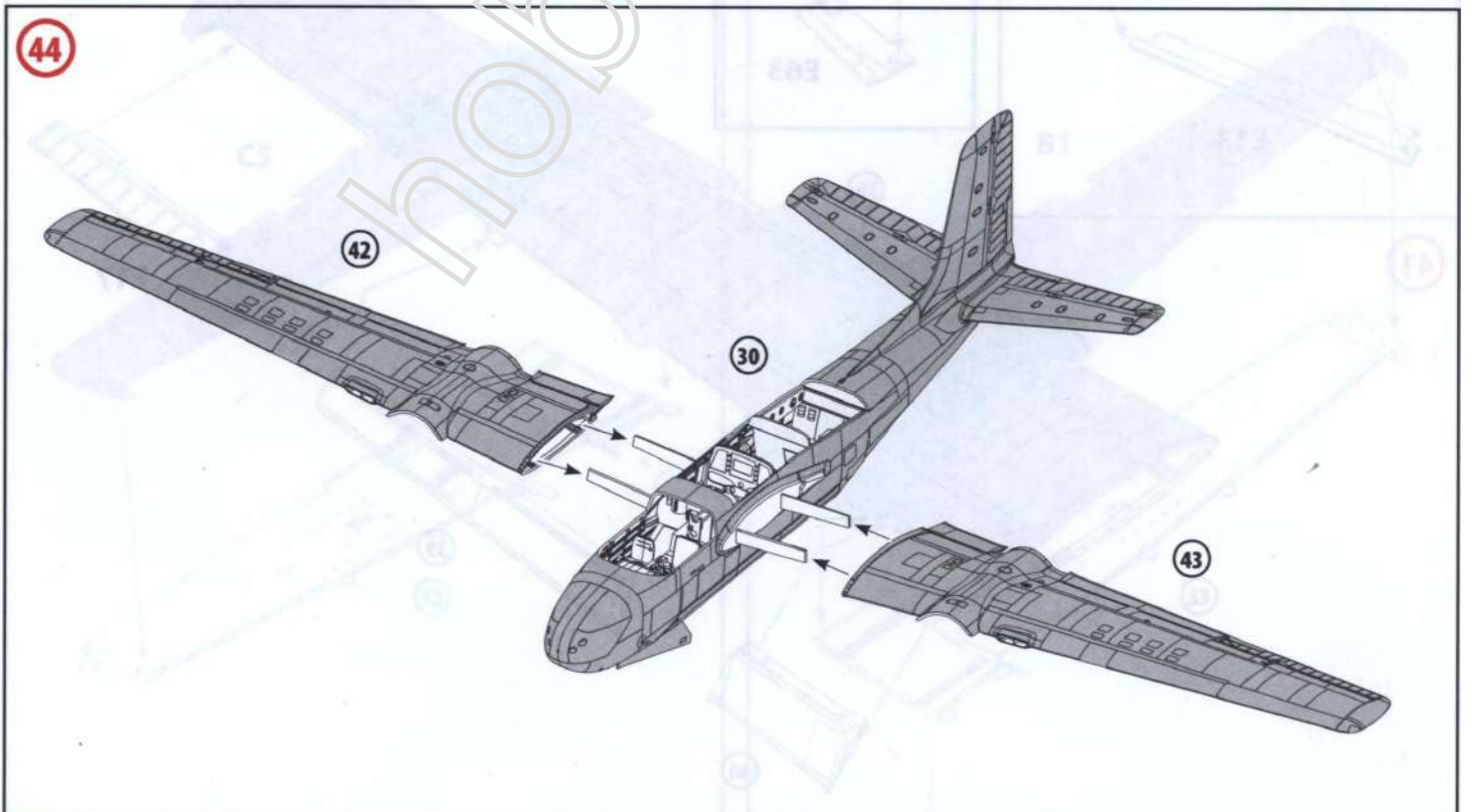
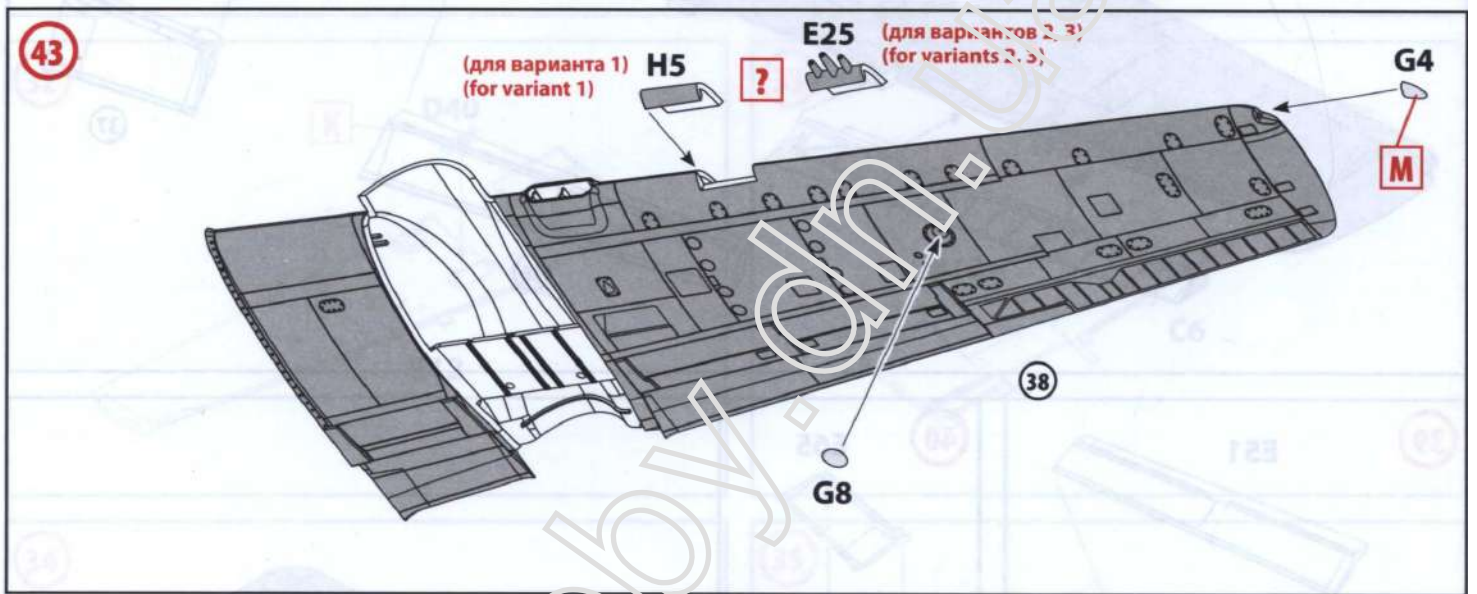
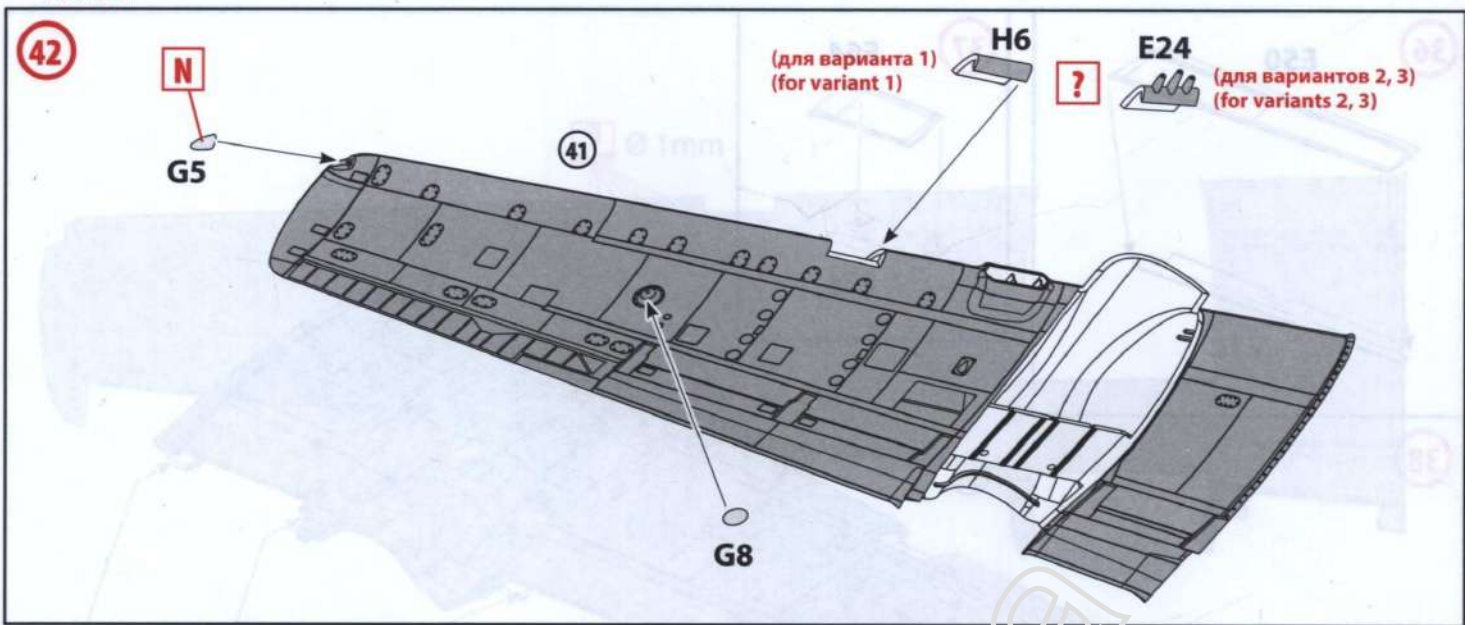

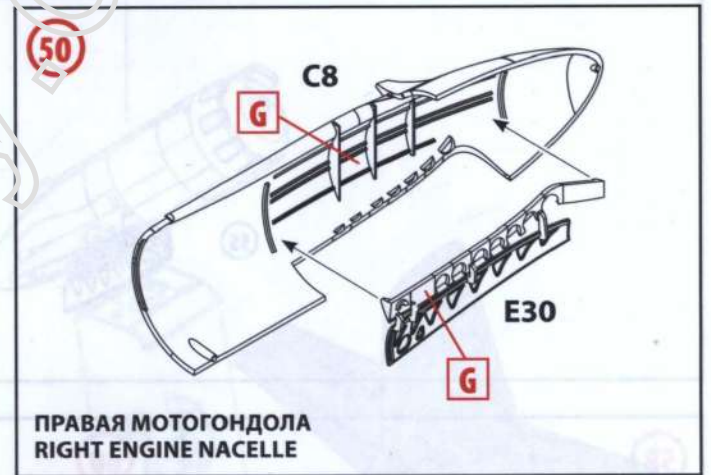
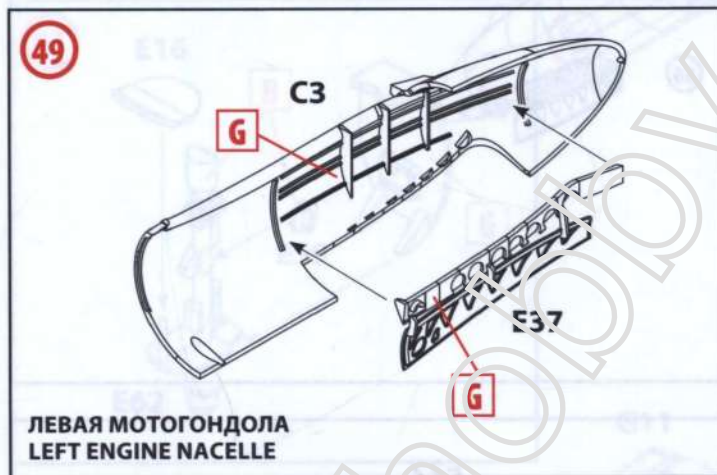
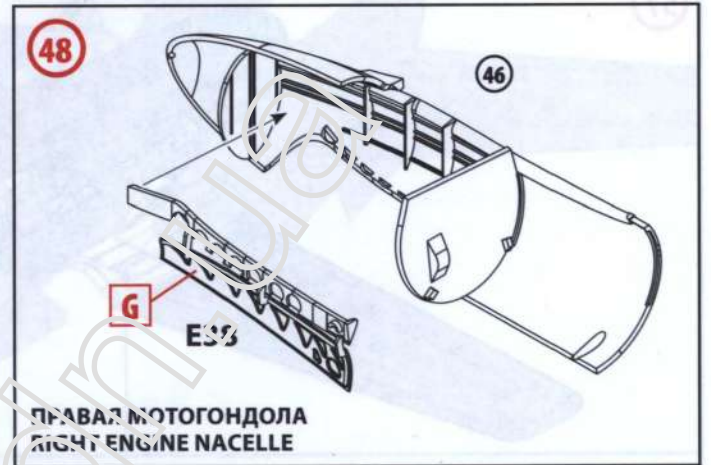
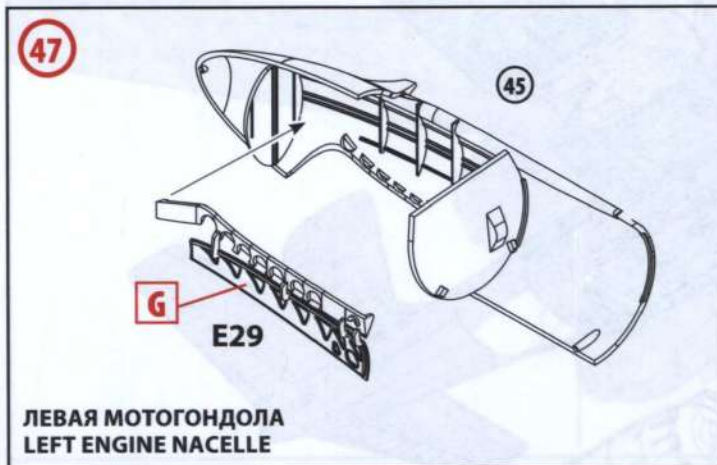
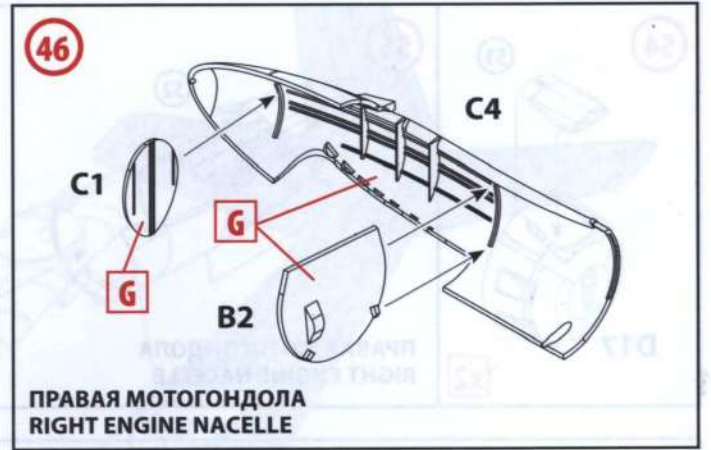
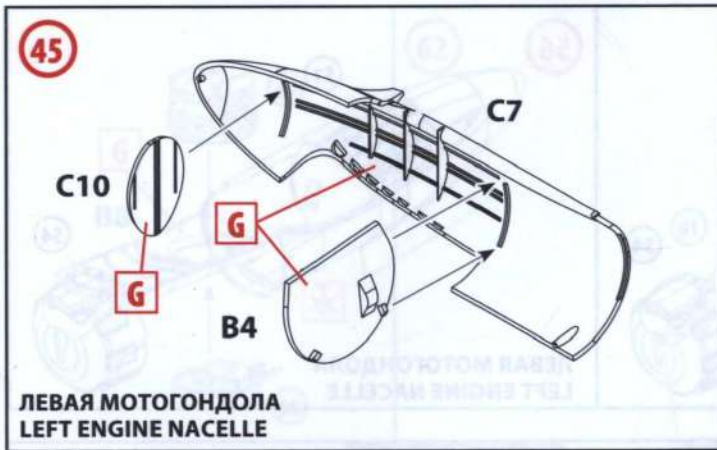

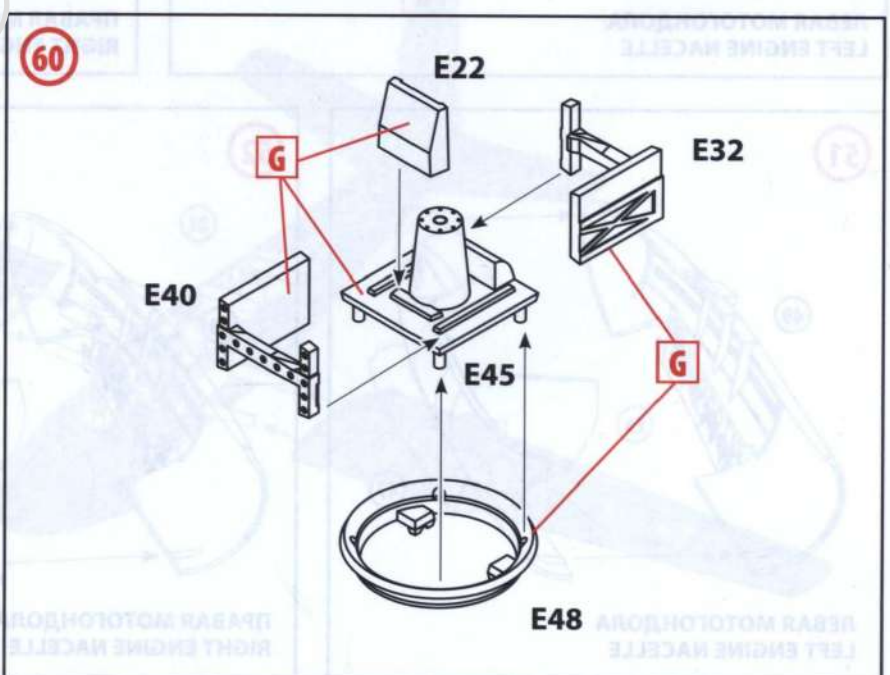
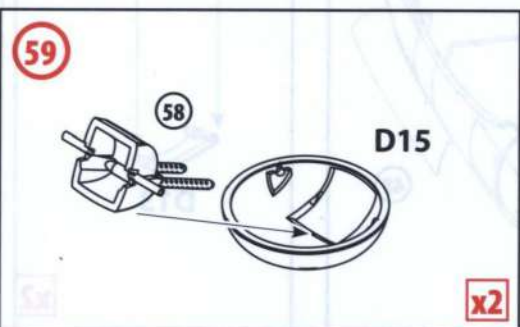
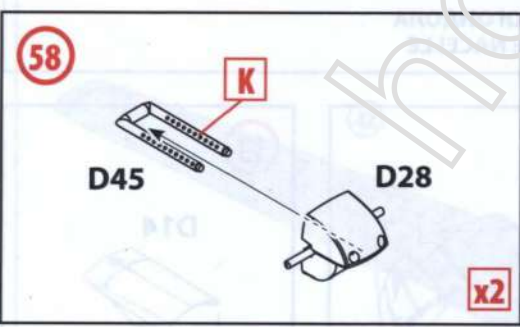
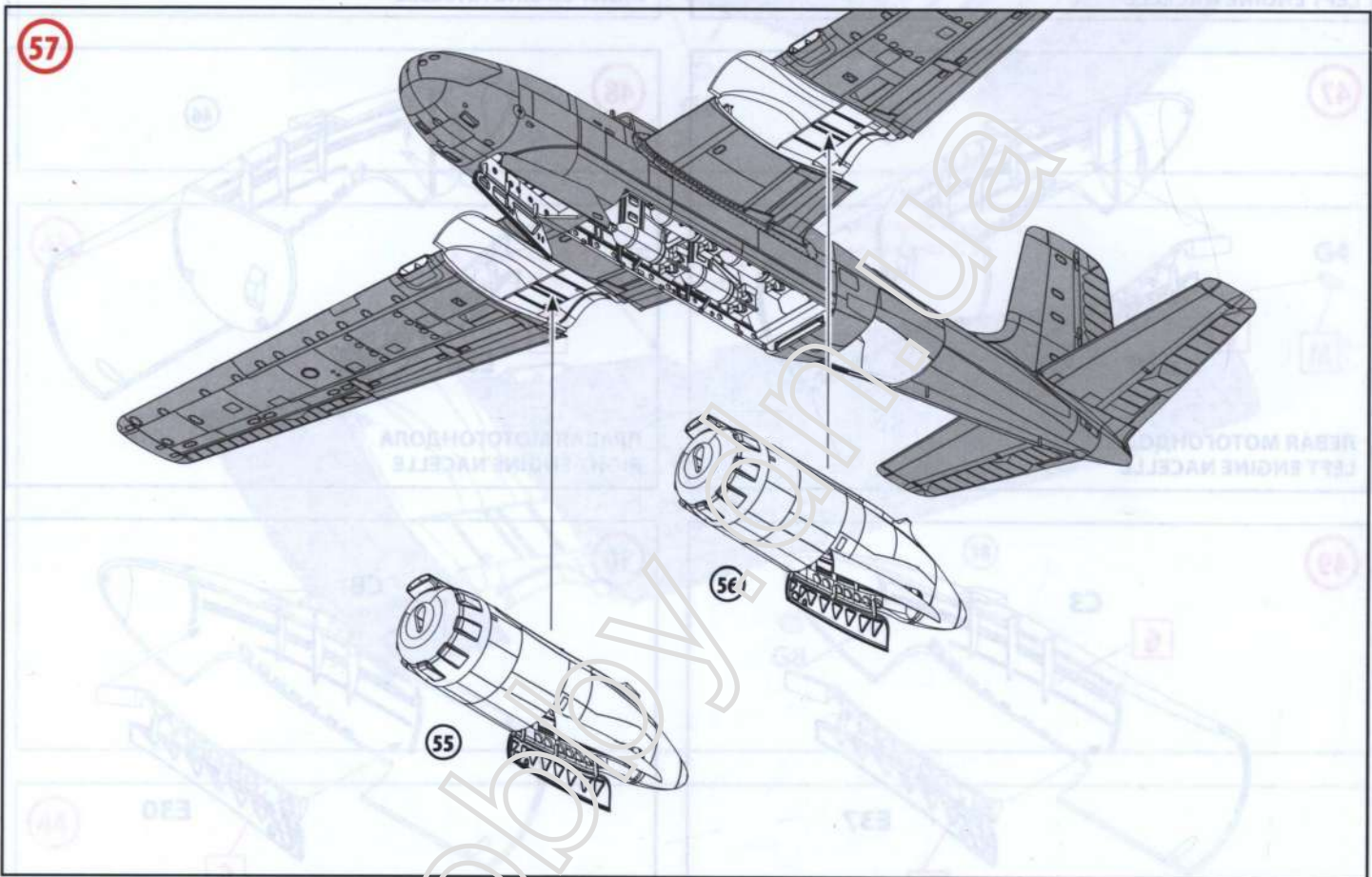
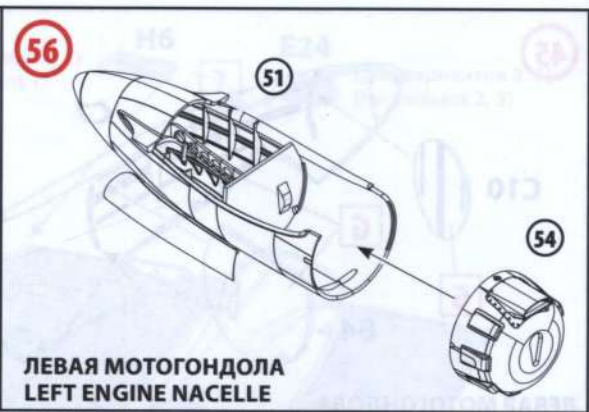
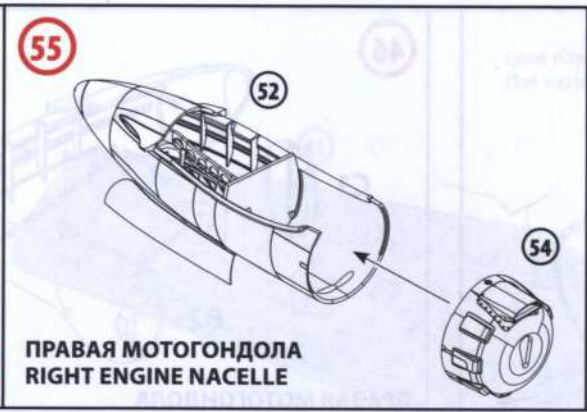
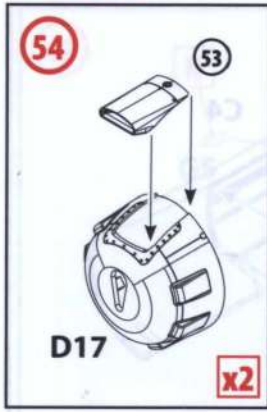

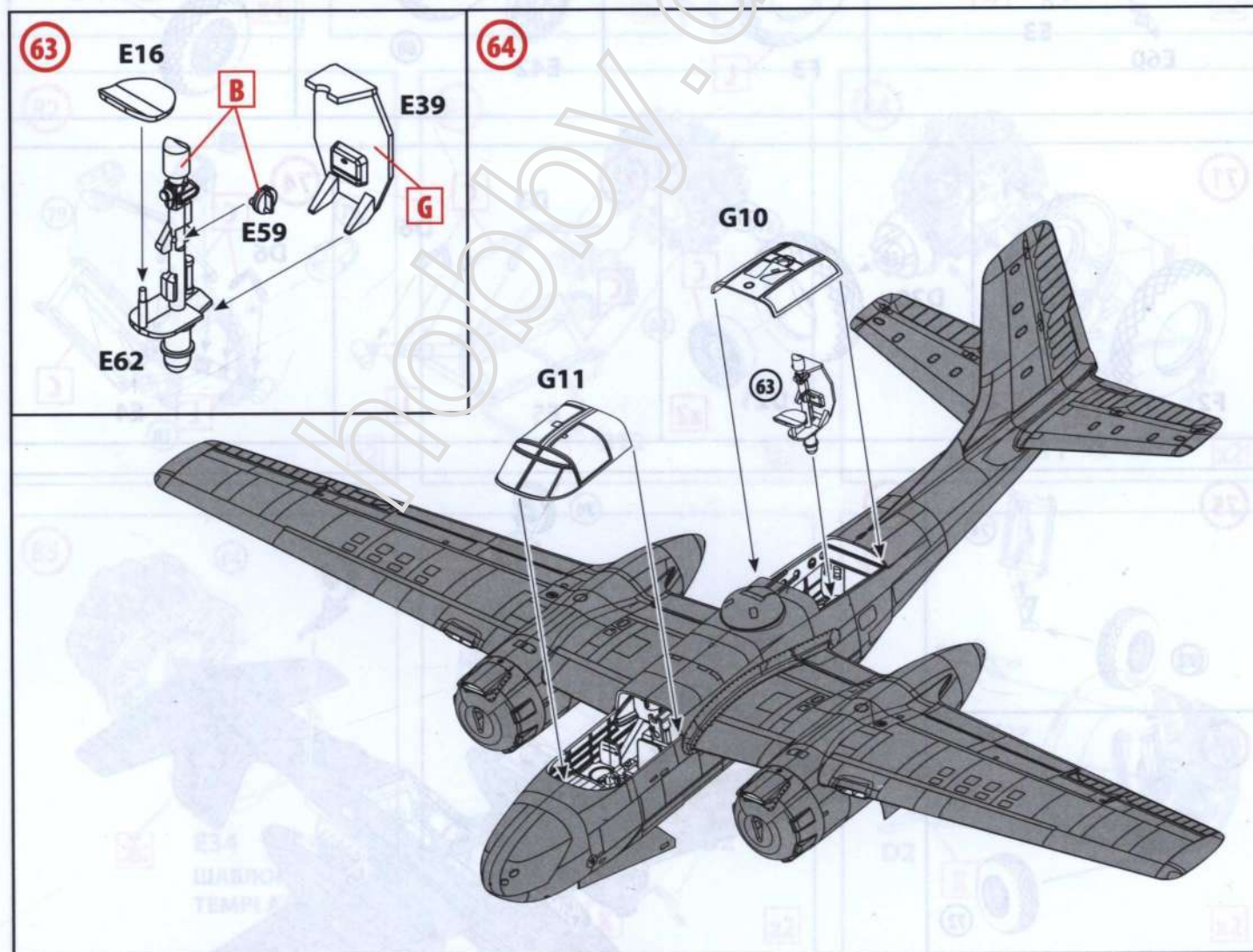
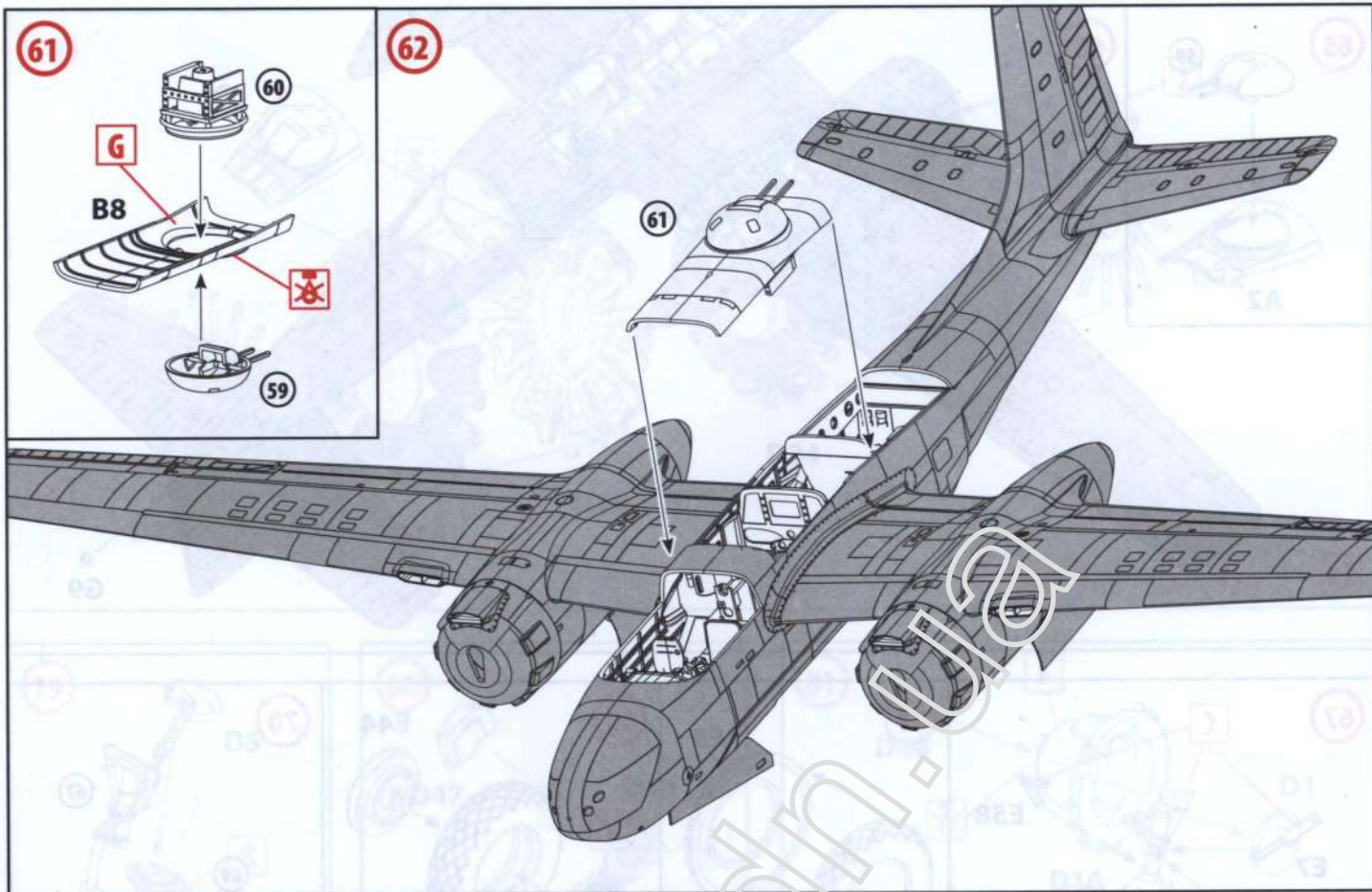

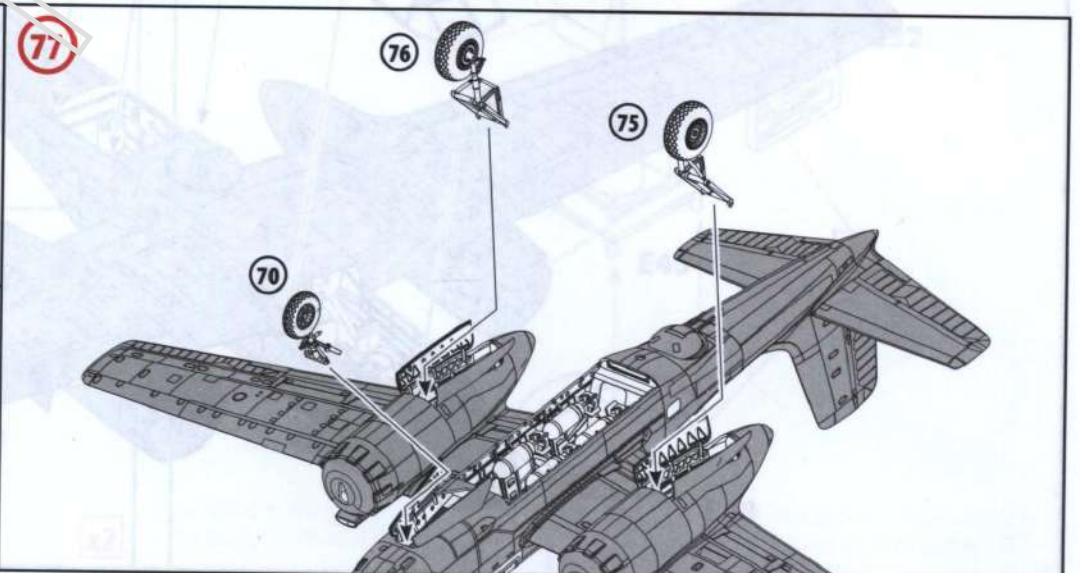
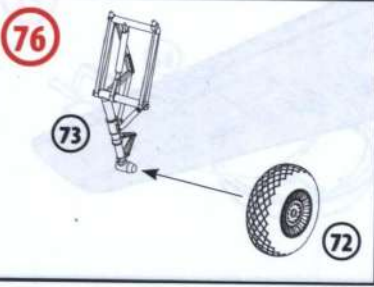
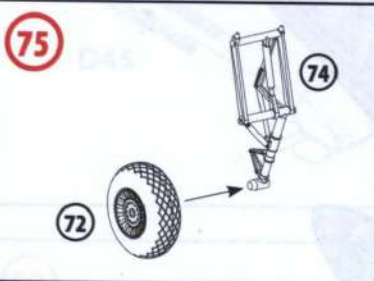
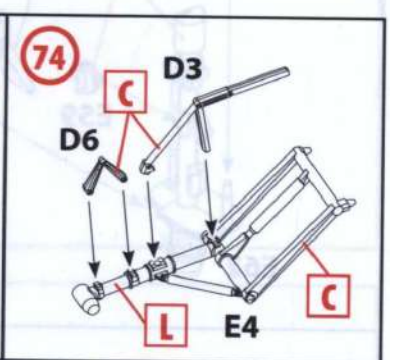
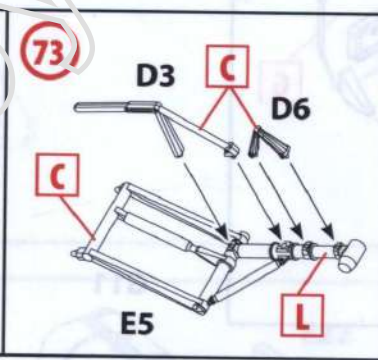
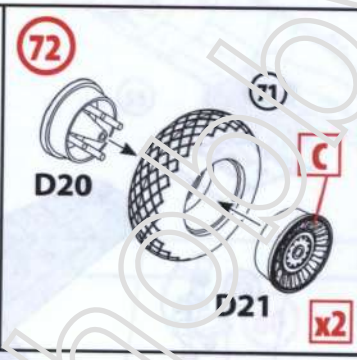
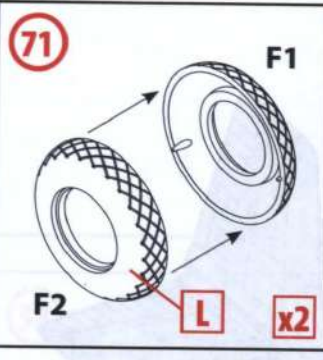
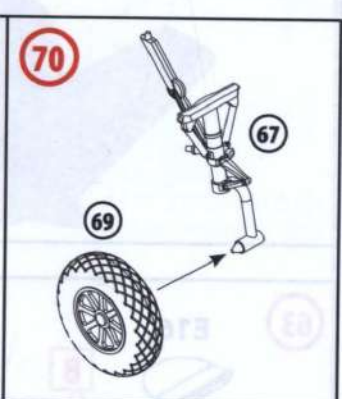
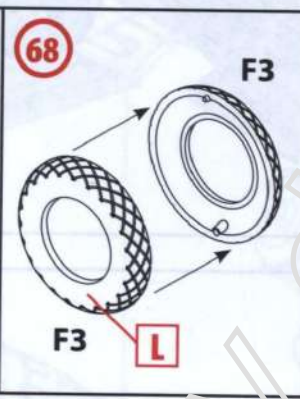
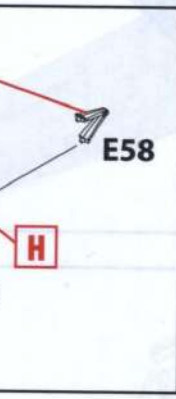
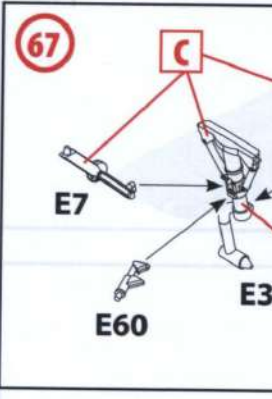
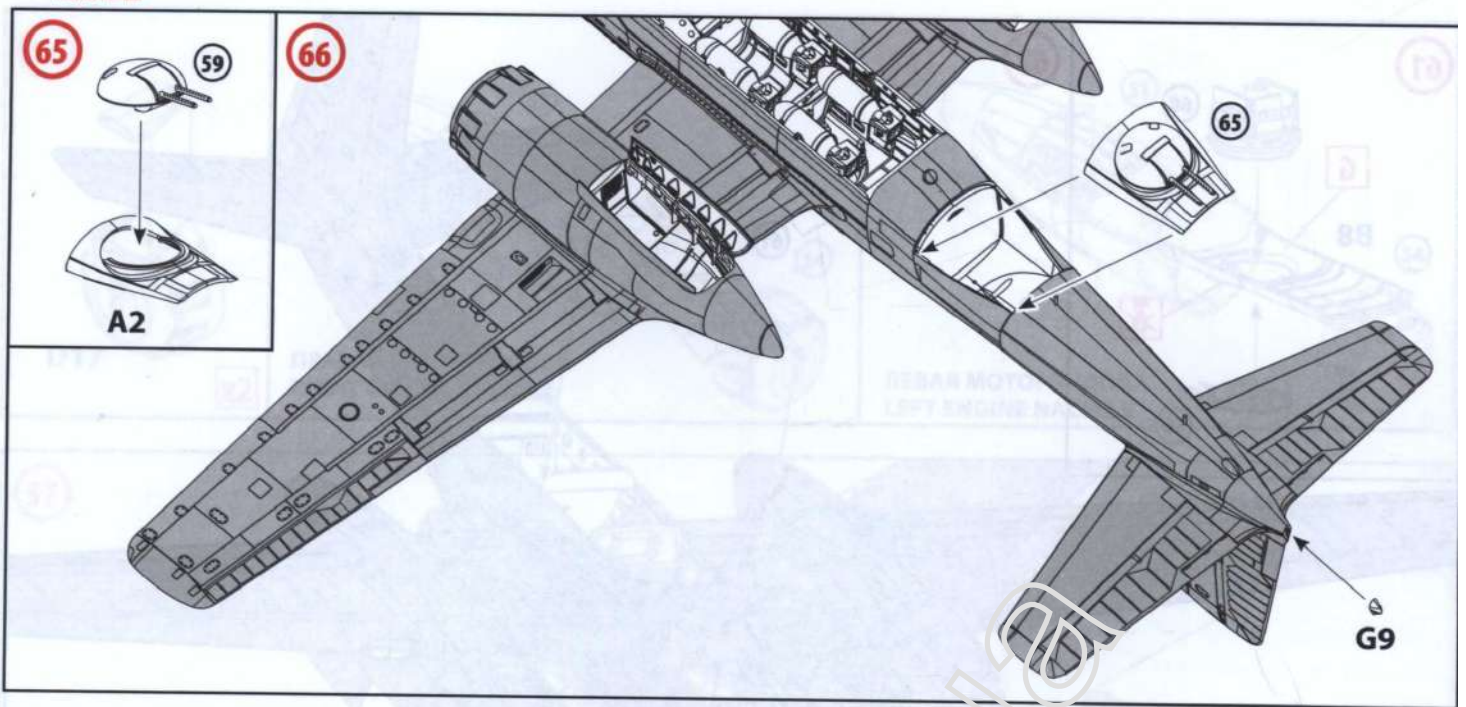



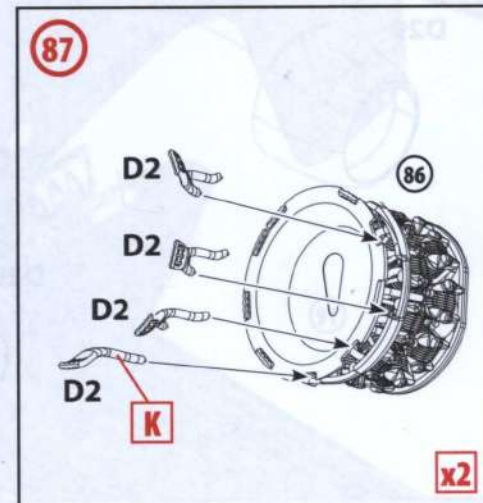
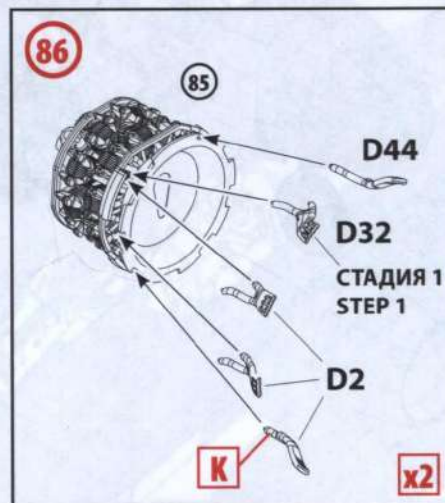
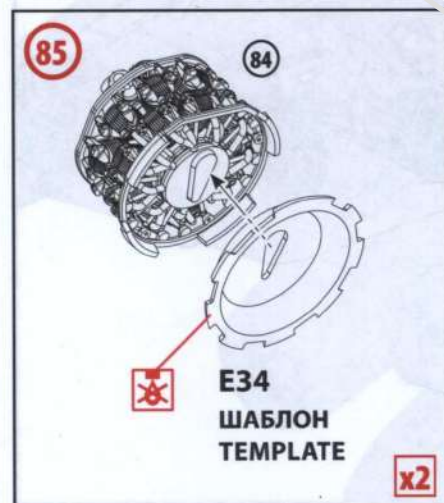
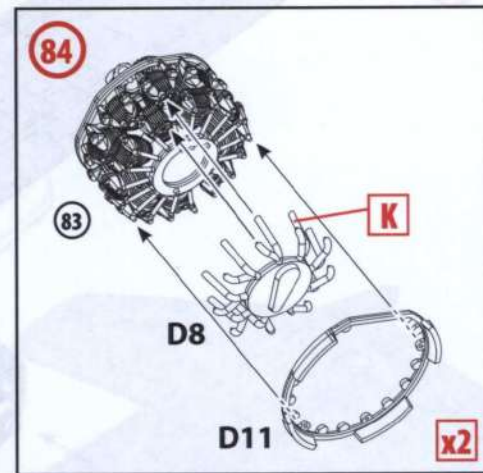
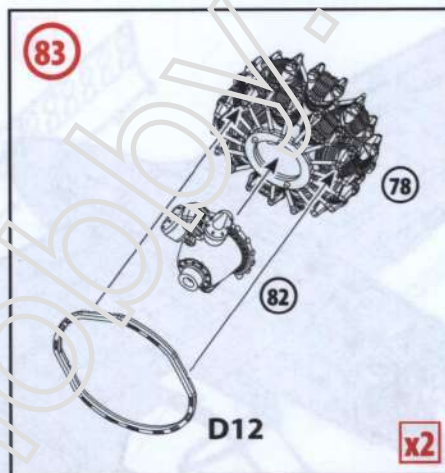
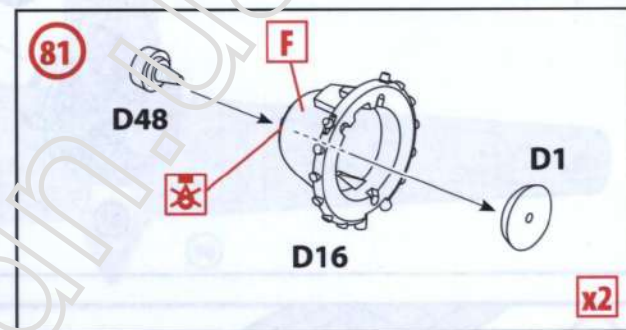
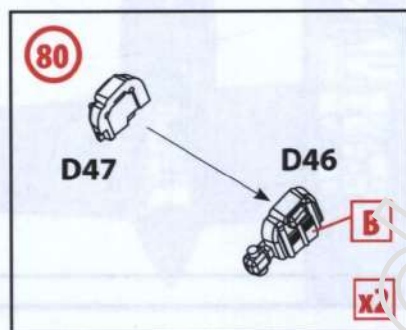
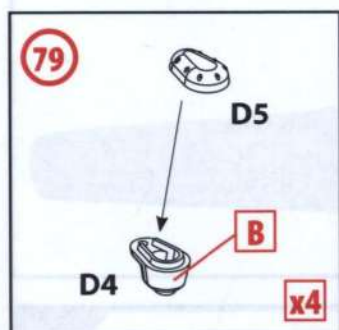
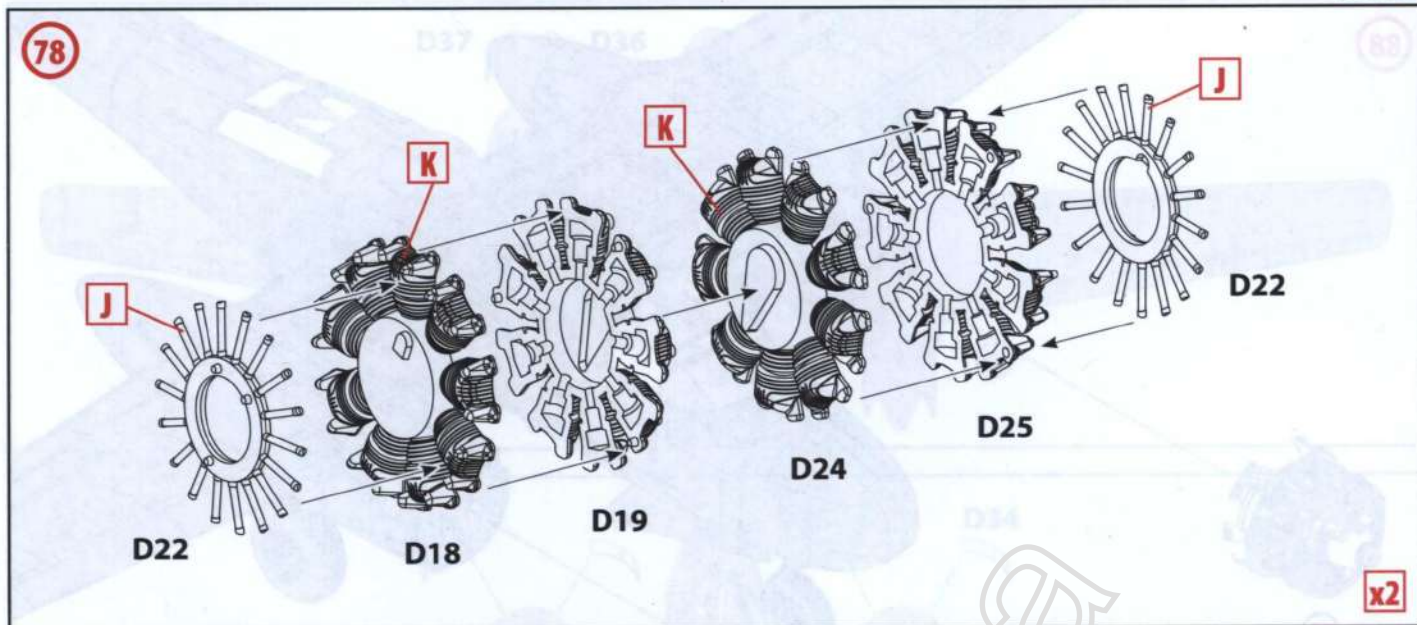

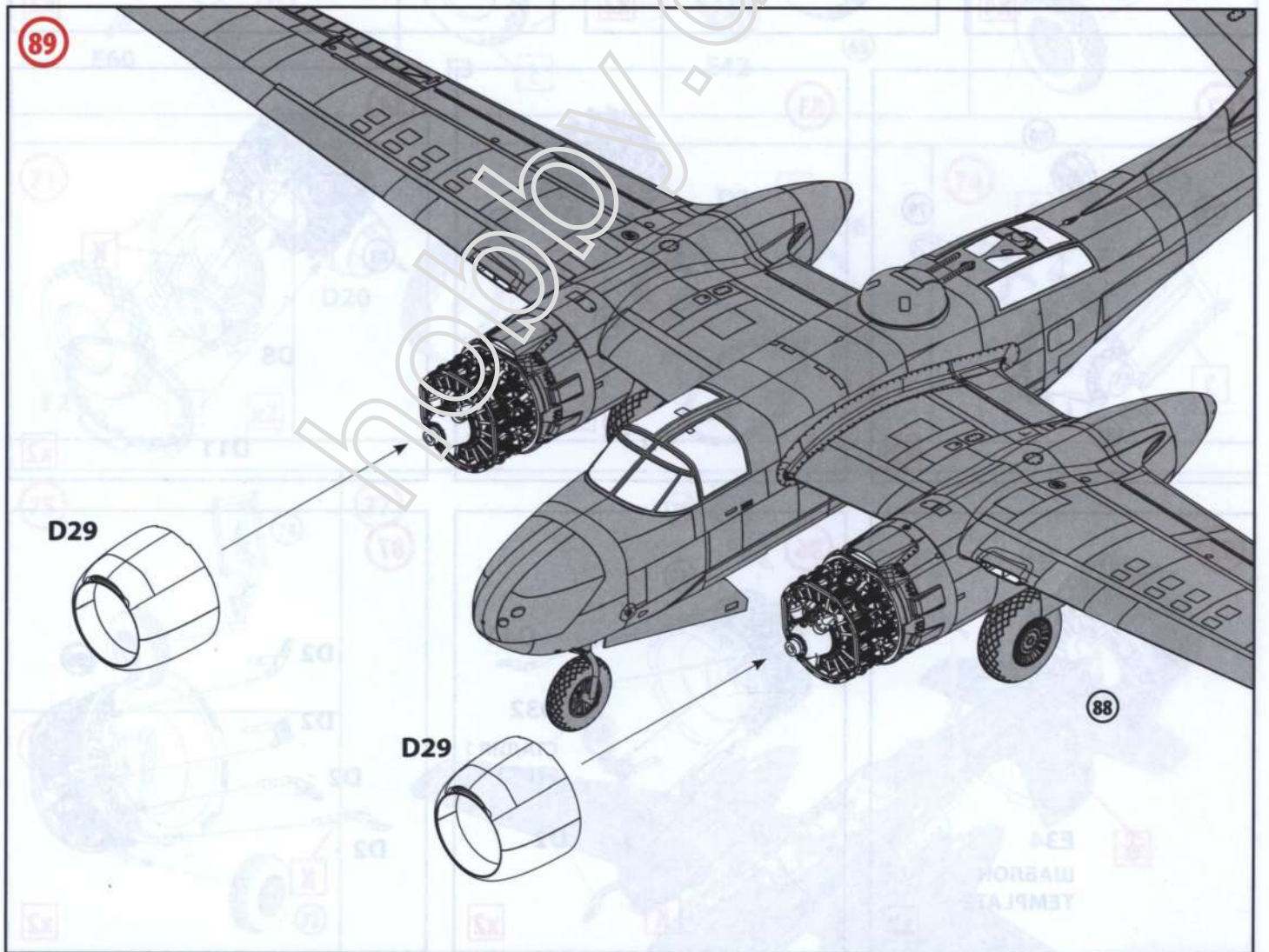
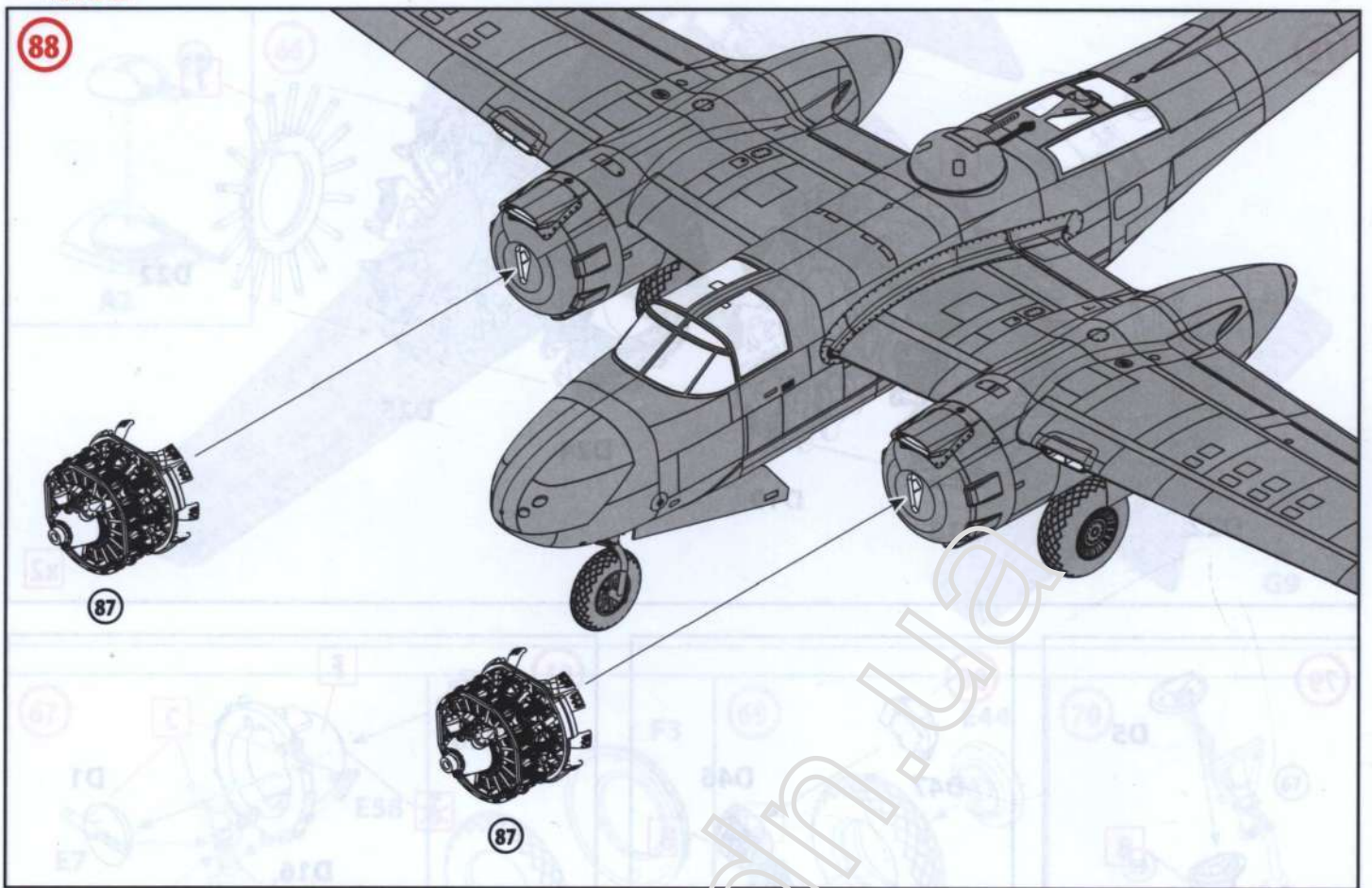

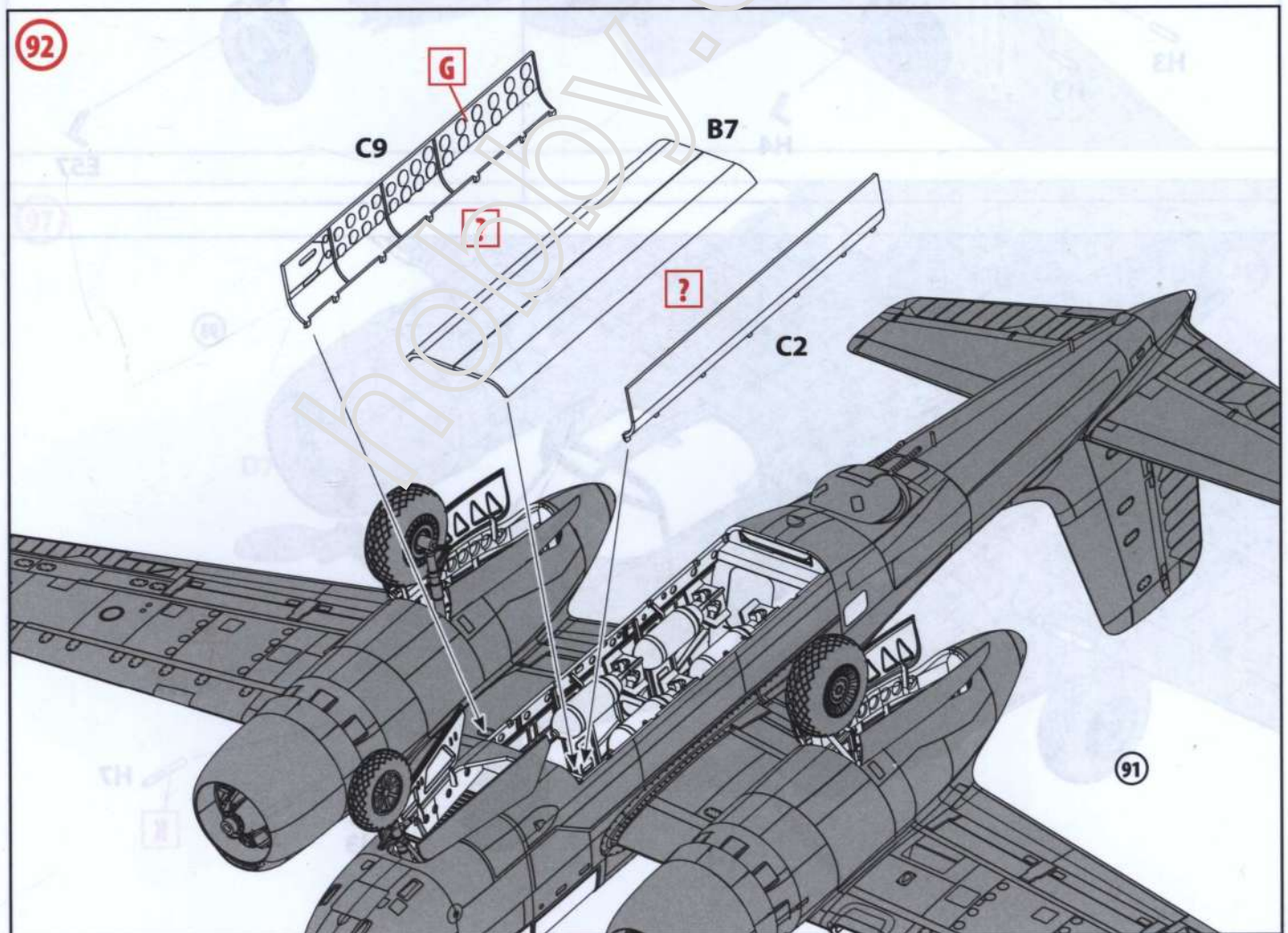
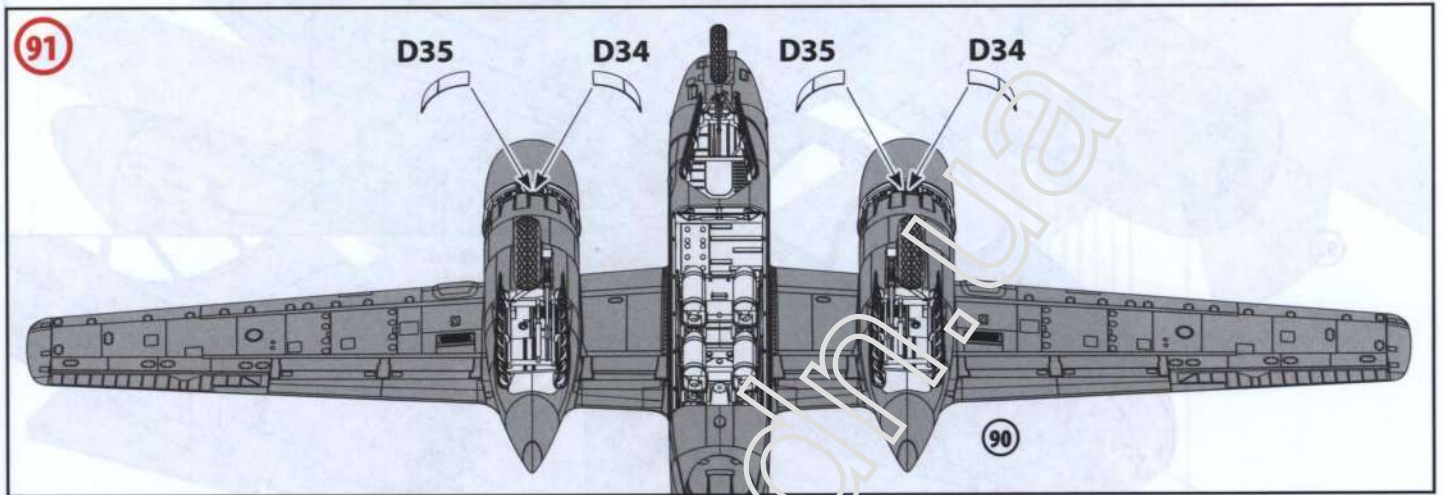
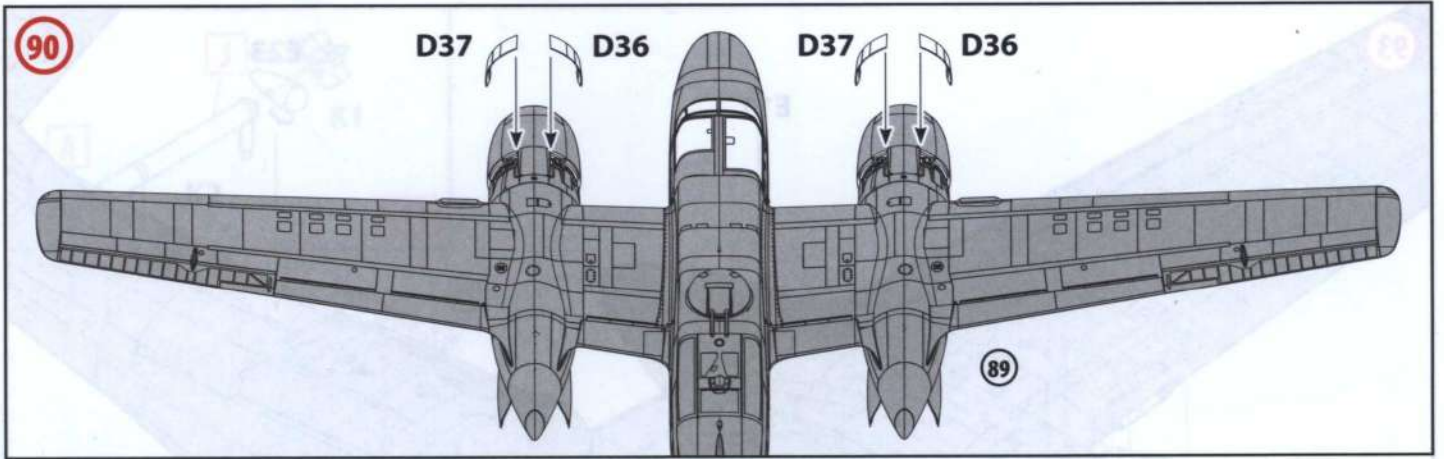

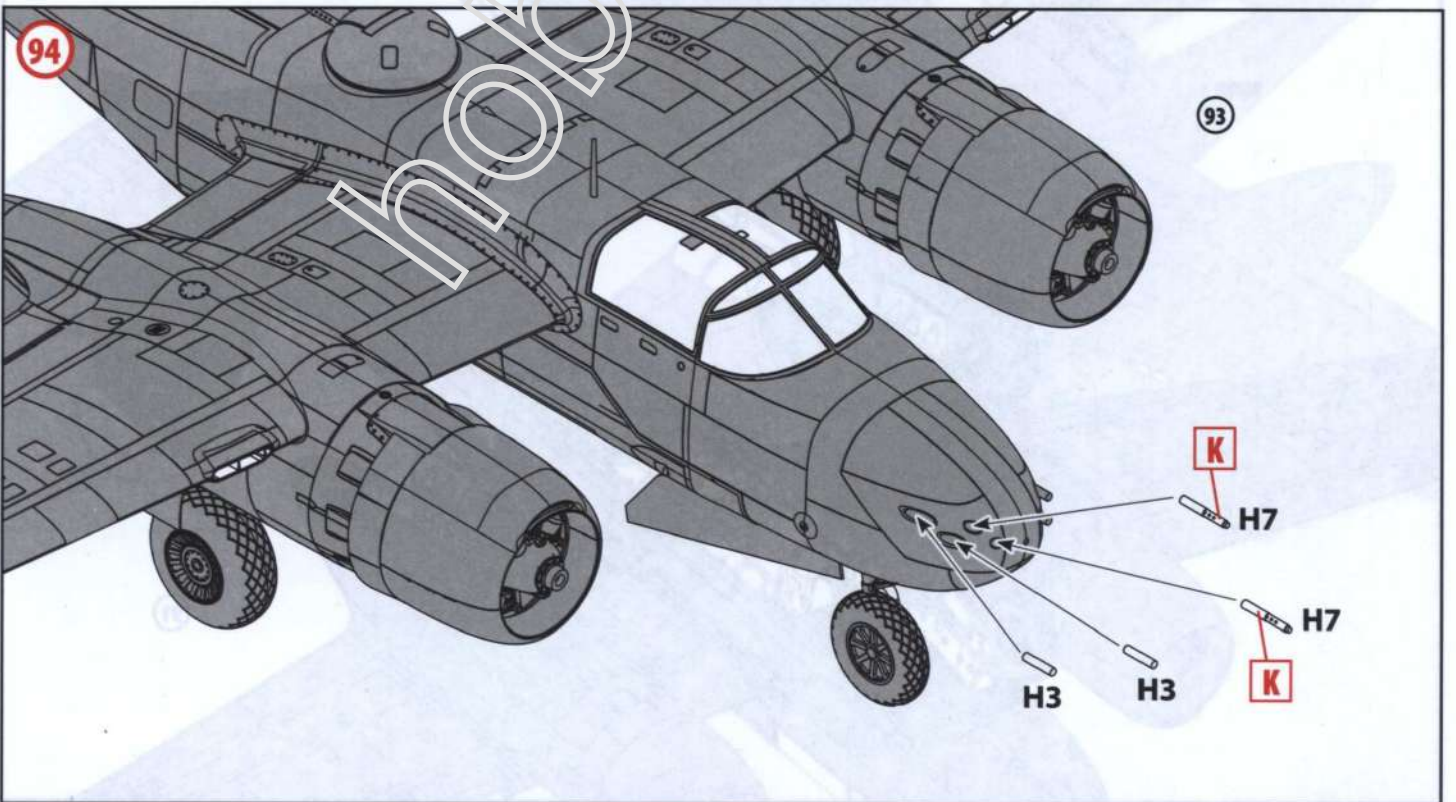
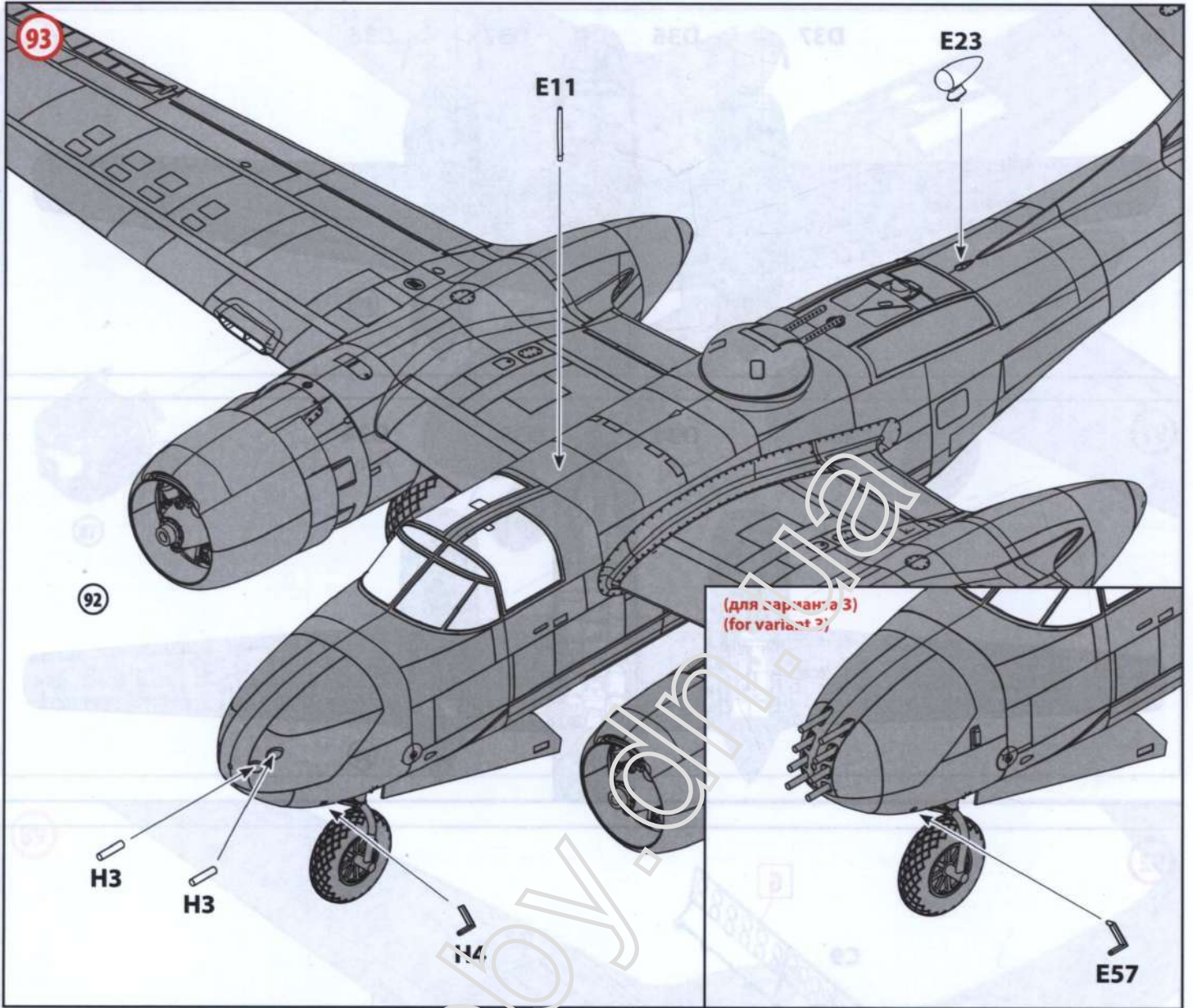

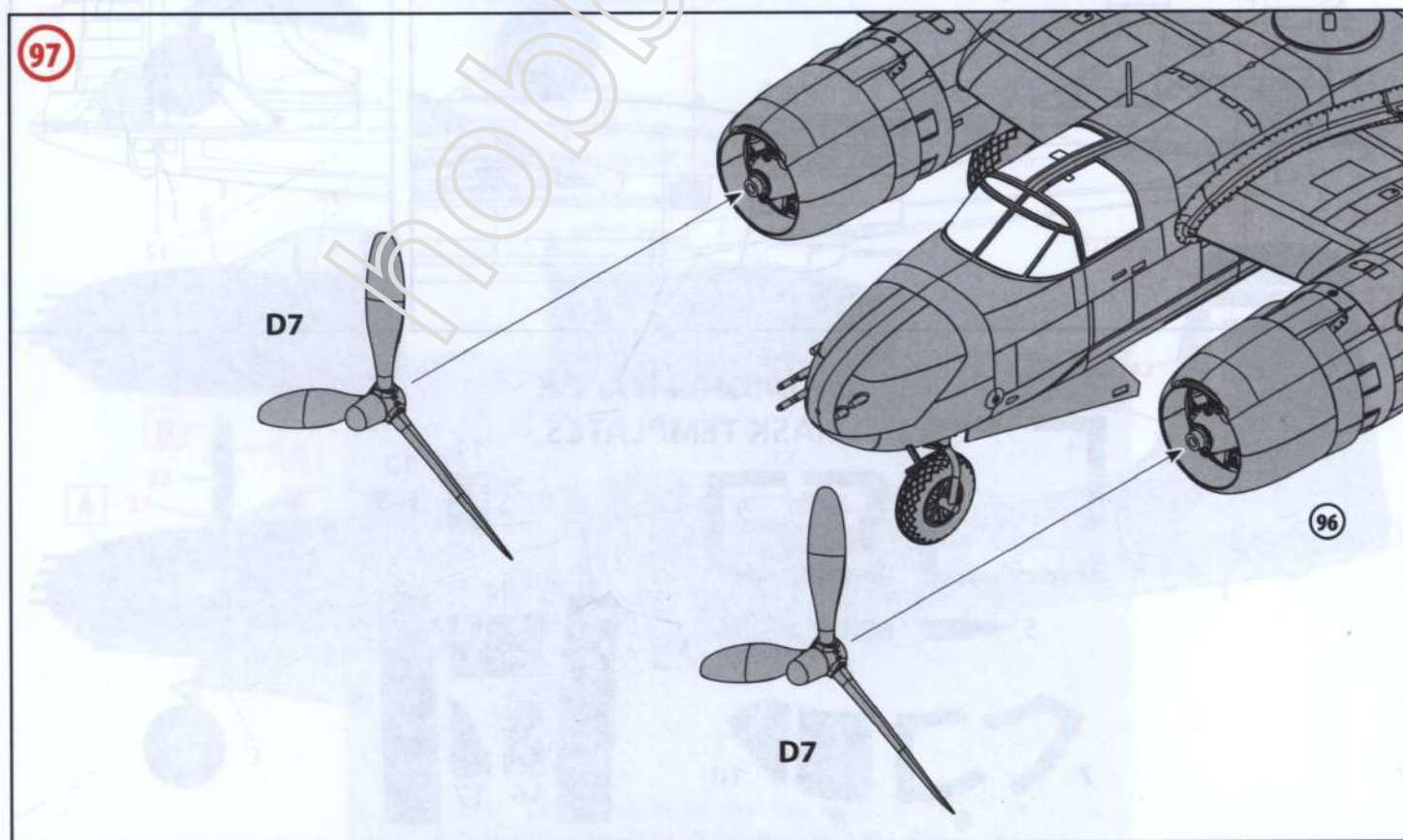
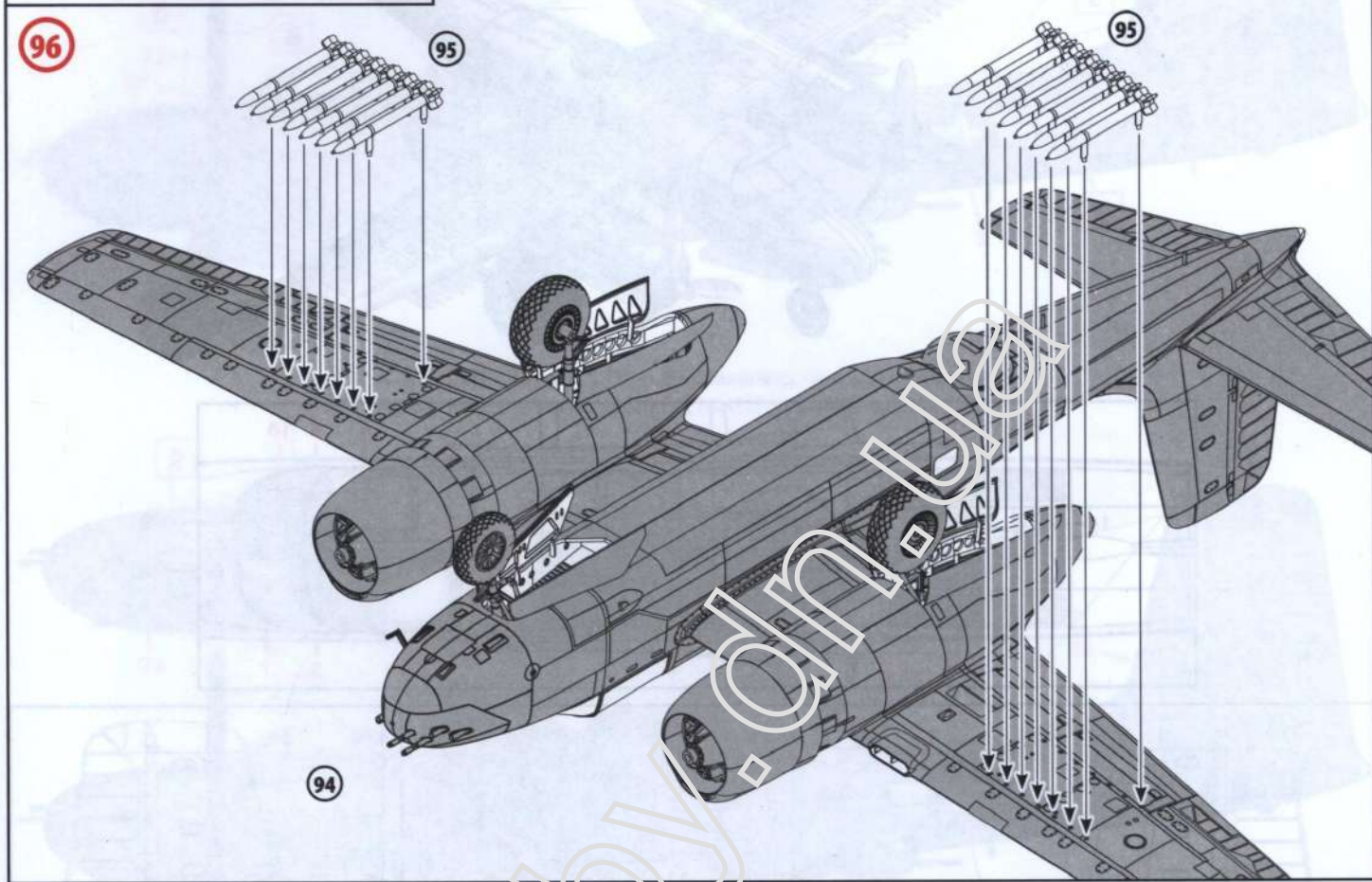
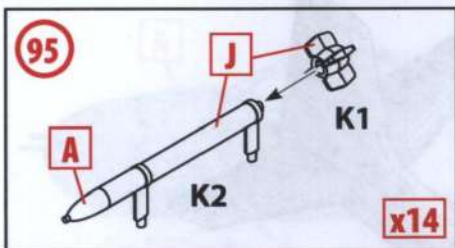

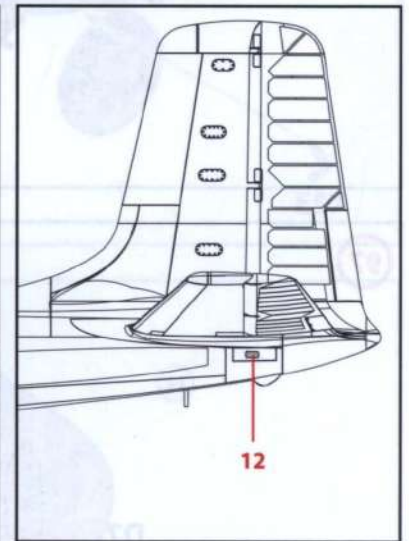
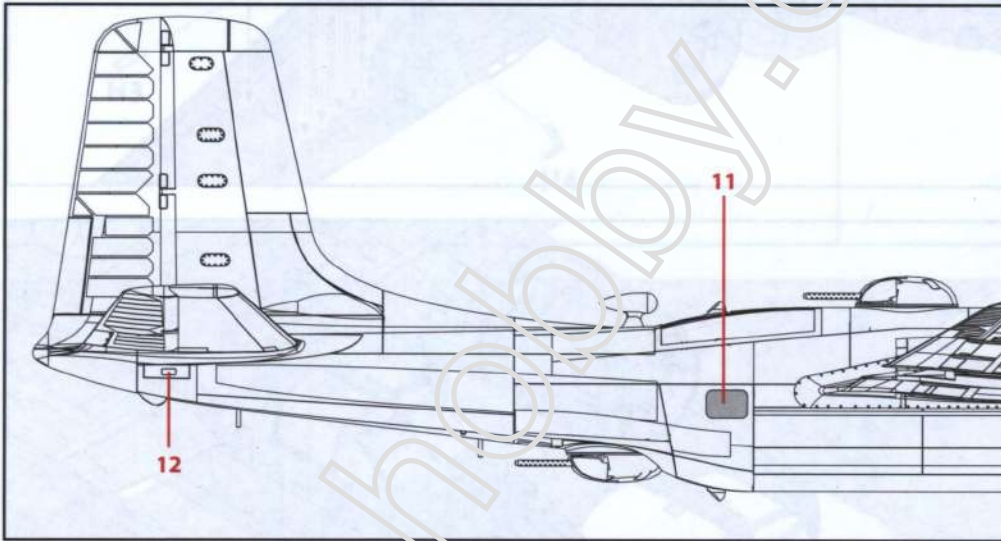
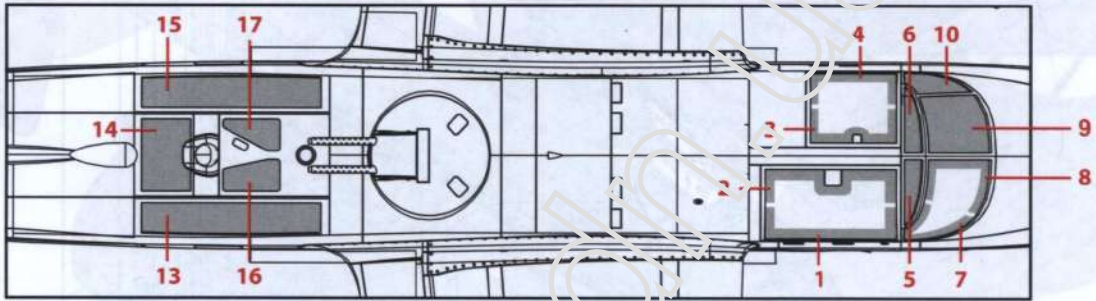
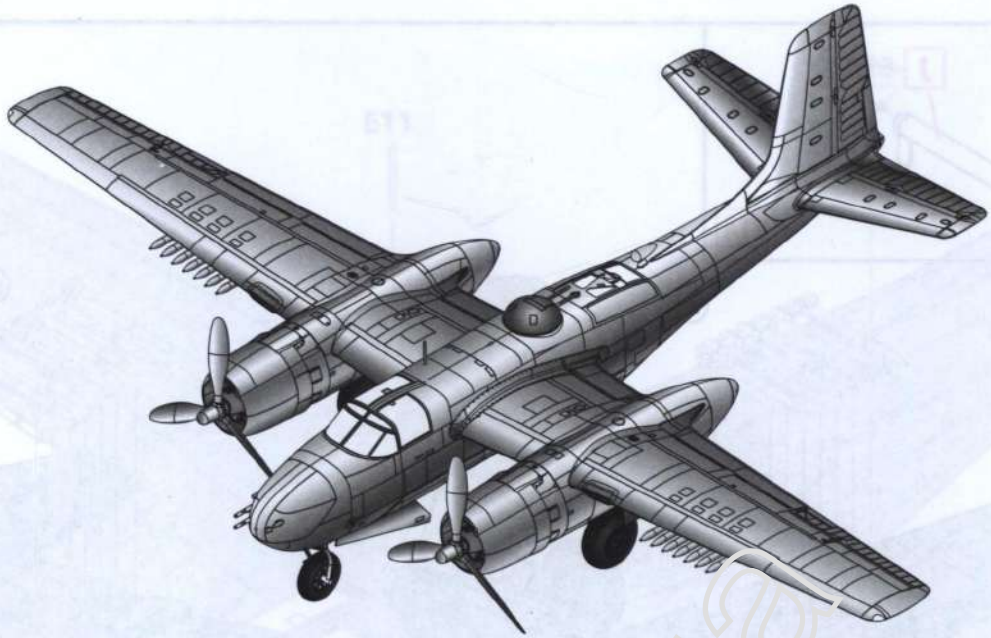

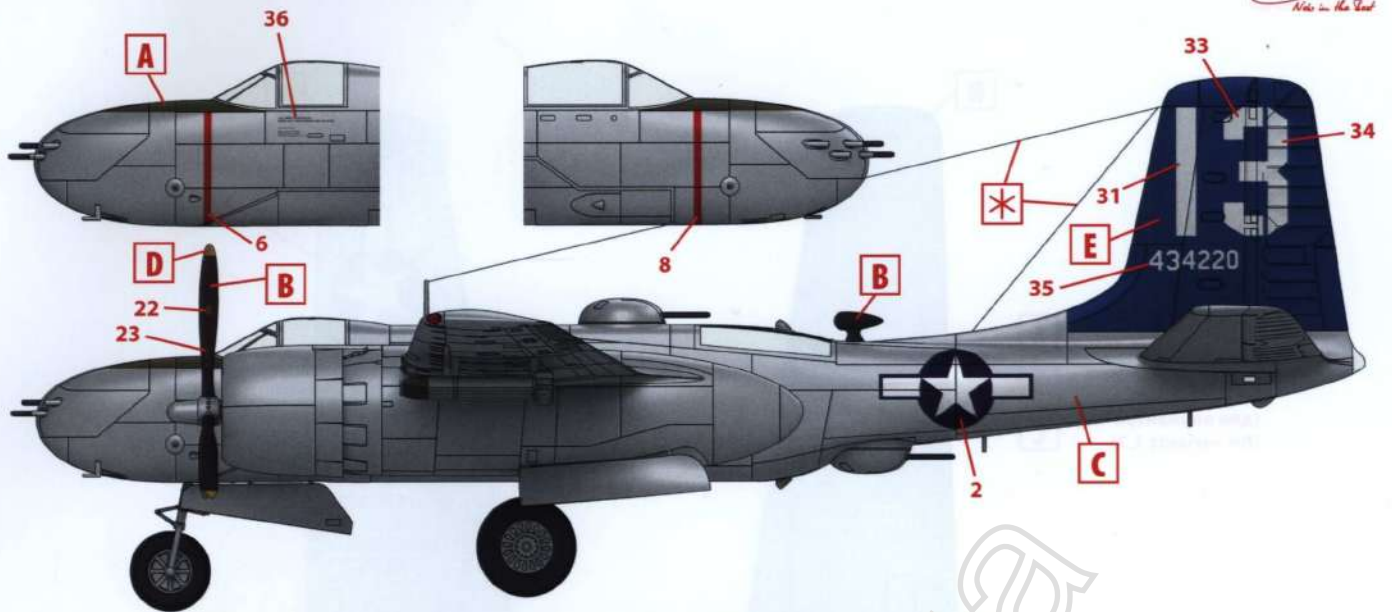

1. A-26B-50-DL, 437-й BS, 319-я BG, Макинато, Окинава, июль 1945 г.  
 A-26B-50-DL, 437th BS/319th BG, Machinato, Okinawa, July 1945

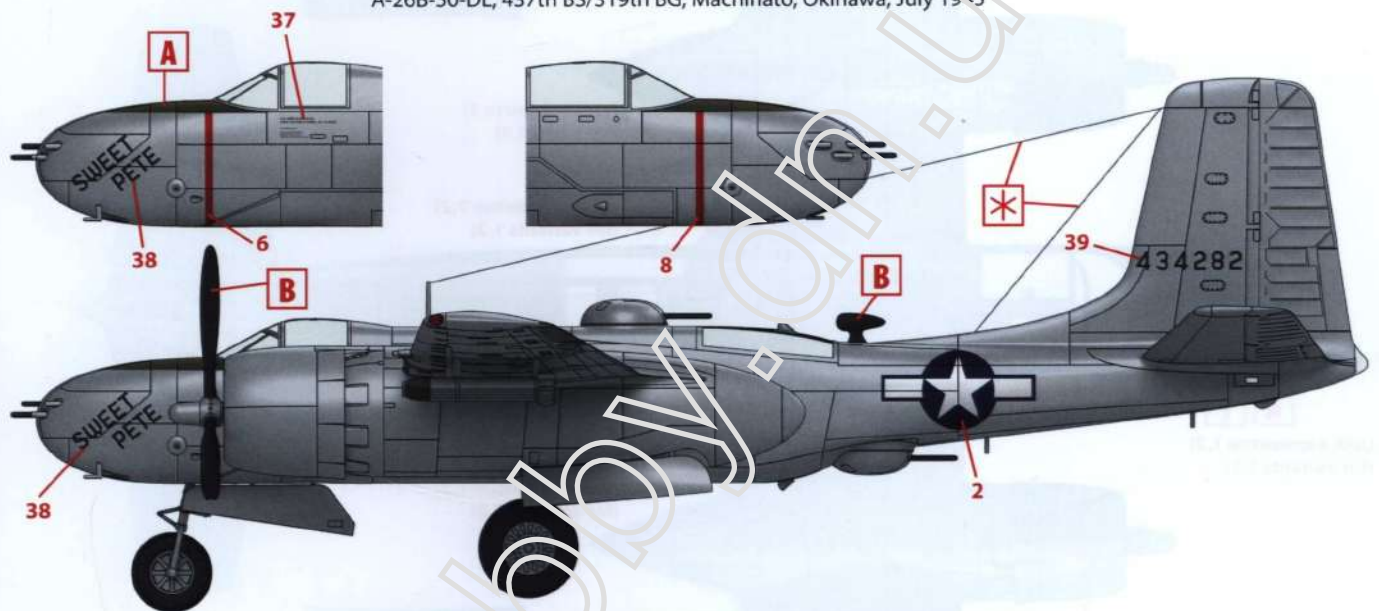

2. A-26B-50-DL, 344-й BS, 319-я BG, Макинато, Окинава, июль 1945 г.  
 A-26B-50-DL, 344th BS/319th BG, Machinato, Okinawa, July 1945

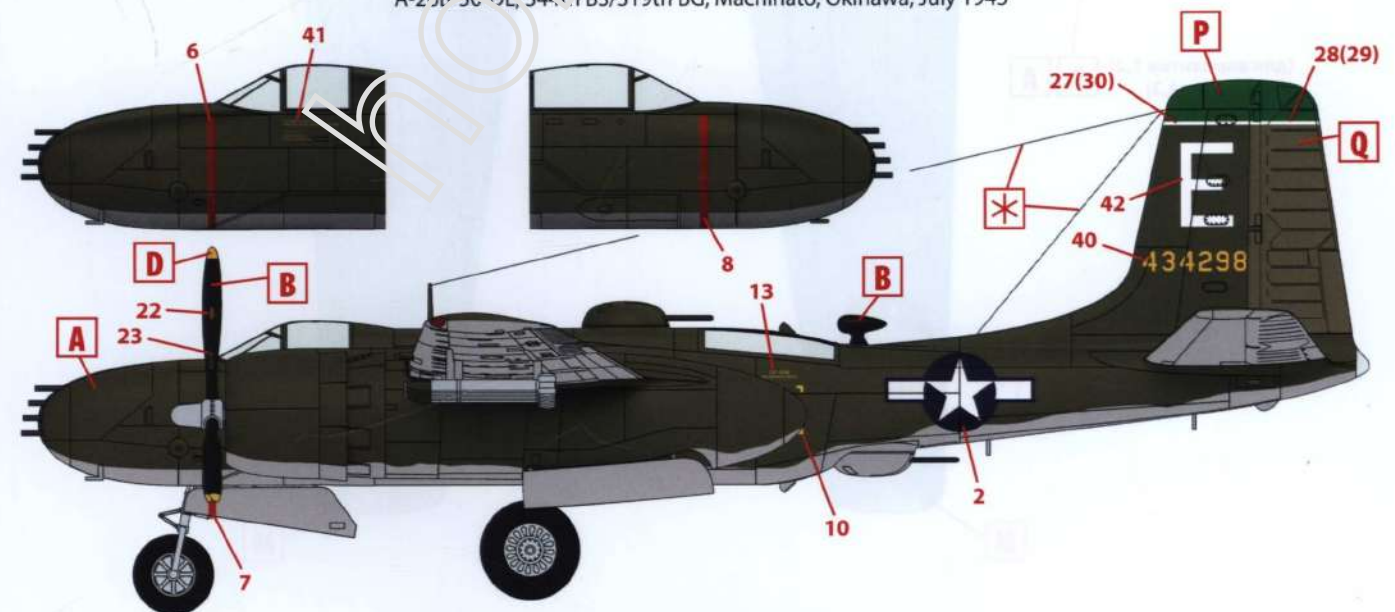

3. A-26B-51-DL, 89-й BS, 3-я BG, Окинава, август 1945 г.  
 A-26B-51-DL, 89th BS/3d BG, Okinawa, August 1945

**N**

**N**

(для варианта 3)  
(for variant 3)

**A**

(для вариантов 1,2)  
(for variants 1,2)

**?**

**C**

11

(для варианта 3)  
(for variant 3)

**24**

**?**

(для вариантов 1,2)  
(for variants 1,2)

**25**

**A** **?**

(для вариантов 1,2)  
(for variants 1,2)

(для варианта 3)  
(for variant 3)

**24**

**?**

(для вариантов 1,2)  
(for variants 1,2)

**25**

11

(для вариантов 1,2)  
(for variants 1,2)

**?**

**A**

1

**M**

**M**

