



МиГ-25ПД

Советский истребитель-перехватчик

В конце 60-х годов в ОКБ А. И. Микояна был разработан первый в мире истребитель-перехватчик со скоростью полета 3М – МиГ-25.

Модификация МиГ-25ПД с усовершенствованным радиоэлектронным оборудованием и ракетным вооружением производилась с 1978 г. В конце 70-х и в 80-х годах он был основным истребителем – перехватчиком ПВО СССР.

Эти не имеющие аналогов самолеты-истребители состояли на вооружении ВВС СССР (впоследствии – России), а также экспортировались в Ирак, Сирию и Ливию.

Тактико-технические характеристики МиГ-25ПД

Длина, м.....	22,30
Размах крыла, м.....	14,05
Взлетный вес (нормальный), кг.....	34920
Двигатели.....	2хТРДФ Р-15БД-300, тяга на форсаже – 2х11200 кгс
Максимальная скорость, км/ч.....	3000
Потолок, м.....	20700
Дальность, км.....	1730 / 2400 с ПТБ
Вооружение.....	2 ракеты Р-40РД, 2 ракеты Р-40ТД или 4 ракеты Р-60М

ВНИМАНИЕ!

Перед сборкой внимательно прочитать руководство по монтажу. Каждая деталь пронумерована. Соблюдать последовательность монтажа. Необходимые сабчики и инструменты: нож и напильник для зачистки деталей; резиновая лента, клей, скотч и зажимы для сушки белья для прижимающих склеиваемых деталей. Детали из пластика обработать в растворе мягкого моющего средства и высушить на воздухе для того, чтобы краска и переводная картинка лучше прилипали. Перед приклеиванием проверить, подходят ли детали к клею наносит, экономно. Хром и краску удалить с поверхностей склеивания. Небольшие детали оклеивать перед тем, как они будут удалены из рамок. Краску необходимо хорошо просушить, только после этого продолжать сборку. Каждую соответствующую переводную картинку отдельно срезать и примерно на 20 секунд окунуть в теплую воду. На обозначенном месте картинку отделить от бумаги и прижать промокающей бумагой.

MIГ-25PD

Soviet Interceptor Fighter

In the end of 60s the Mikoyan Design Bureau was developed the world's first interceptor fighter with speed of Mach 3 – the MiG-25.

Modification MiG-25PD with improved avionics and missile weapons was produced since 1978. In late 70s and 80s it was the basic interceptor fighter of the USSR anti-aircraft defense.

These perfect planes served in Soviet (later – Russian) Air Force, and were delivered to Iraq, Syria and Libya.

Tactical and Technical Specifications of MiG-25PD

Length, m.....	22,30
Span, m.....	14,06
Start weight (normal), kg.....	34920
Engines.....	2xR15BD-300, thrust in afterburner - 2x11200 kgf
Max. Speed, km/h.....	3000
Service ceiling, m.....	20700
Range, km.....	1730 / 2400 with drop tank
Armament.....	2 R-40RD missiles, 2 R-40TD or 4 R-60M missiles

CAUTION!

Read the instructions thoroughly prior to assembly. Each component is numbered. Adhere to specified sequence of assembly. Tools required: knife and file for removal of components from frame; rubber bond, adhesive tape and clothes pegs for clamping components together after applying adhesive. Clean plastic components in a mild detergent solution and allow to air-dry so that paint and transfers adhere better. Prior to applying adhesive, check to see whether the components fit together; apply adhesive sparingly. Remove chrome and paint from the contact surfaces. Paint small components before removing them from the frame. Allow paint to dry well, and only then continue to assemble. Cut out each transfer individually and immerse in warm water for approx. 20 seconds. Slide transfer off paper and into designated position, then press on with blotting paper.

ИСПОЛЬЗУЕМЫЕ КРАСКИ / USED COLORS:

	Revell	Tamiya		
A	371	XF80	Светло-серый, полуматовый	Light Grey
B	169	XF75	Темно-серый, матовый	Dark Grey
C	108	XF1	Черный, матовый	Flat Black
D	190	X11	Полированная сталь	Chrome Silver
E	191	X32	Сталь	Steel
F	195	X31	Титан	Titanium Gold

	Revell	Tamiya		
G	199	XF16	Алюминий	Aluminium
H	364	XF5	Зеленый, матовый	Flat Green
J	148	XF71	Сине-зеленый, матовый	Blue Green
K	157	XF20	Серый, матовый	Medium Grey
L	161	X25	Зеленый, глянцевый	Clear Green
M	731	X27	Красный, глянцевый	Clear Red
N	301	X2	Белый, полуматовый	Semigloss White

01 СТАДИЯ СБОРКИ
ASSEMBLY STEP

x2 СДЕЛАТЬ ДВЕ ДЕТАЛИ
MAKE 2 PCS

■ ПРИ СБОРКЕ НЕ ИСПОЛЬЗУЕТСЯ
PARTS NOT FOR USE

? ПРОИЗВОЛЬНЫЙ ВЫБОР
OPTIONAL

03 СБОРОЧНАЯ ЕДИНИЦА
ASSEMBLY UNIT

■ ПРОСВЕРЛИТЬ
OPEN HOLE

A ИСПОЛЬЗУЕМАЯ КРАСКА
USED COLOR

■ ОТРЕЗАТЬ
CUT OFF

***** СДЕЛАТЬ САМОМУ
SCRATCH BUILD

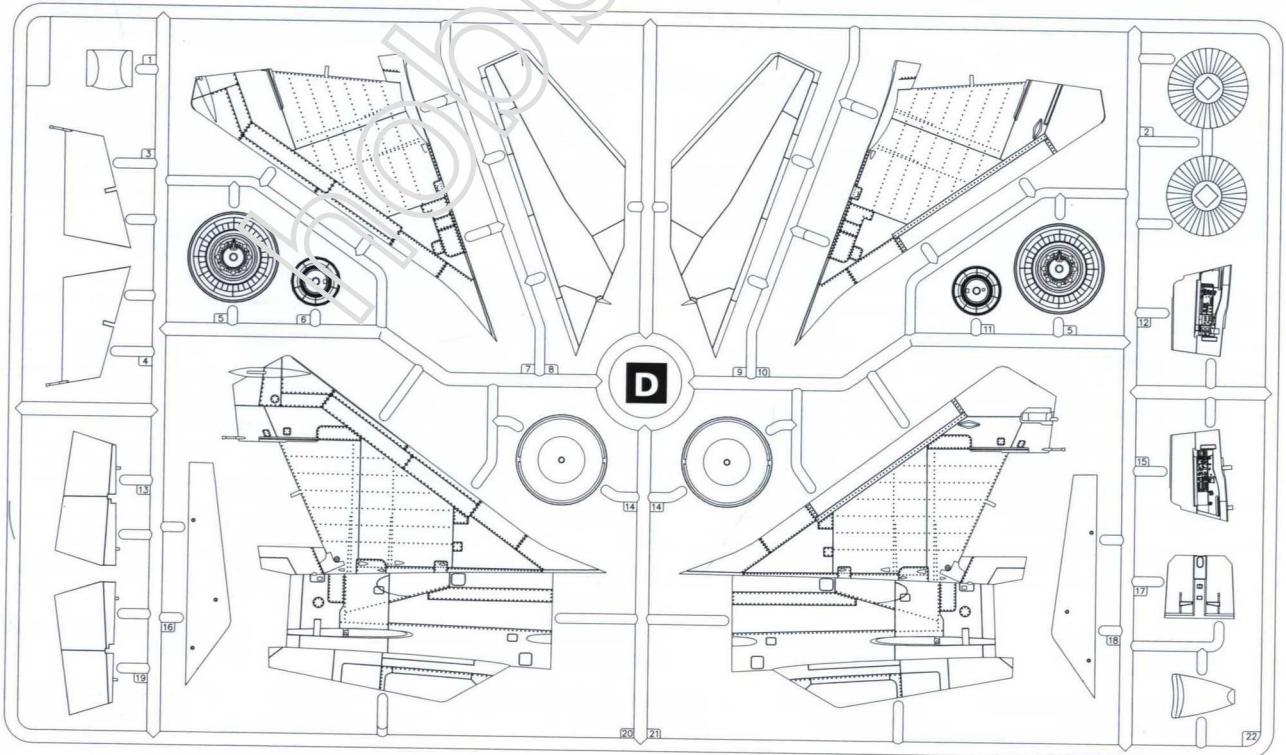
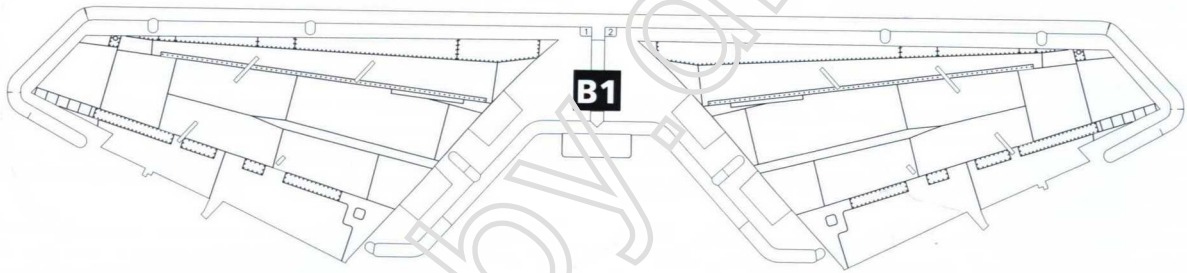
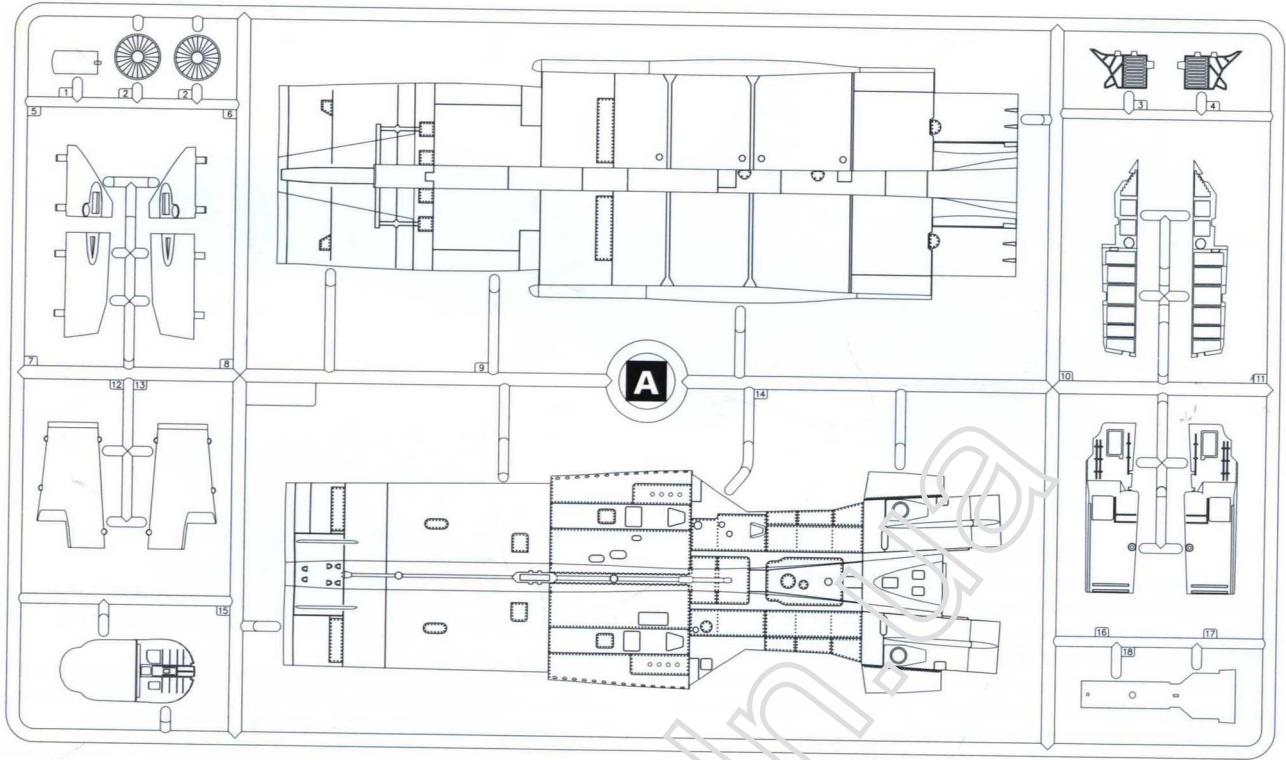

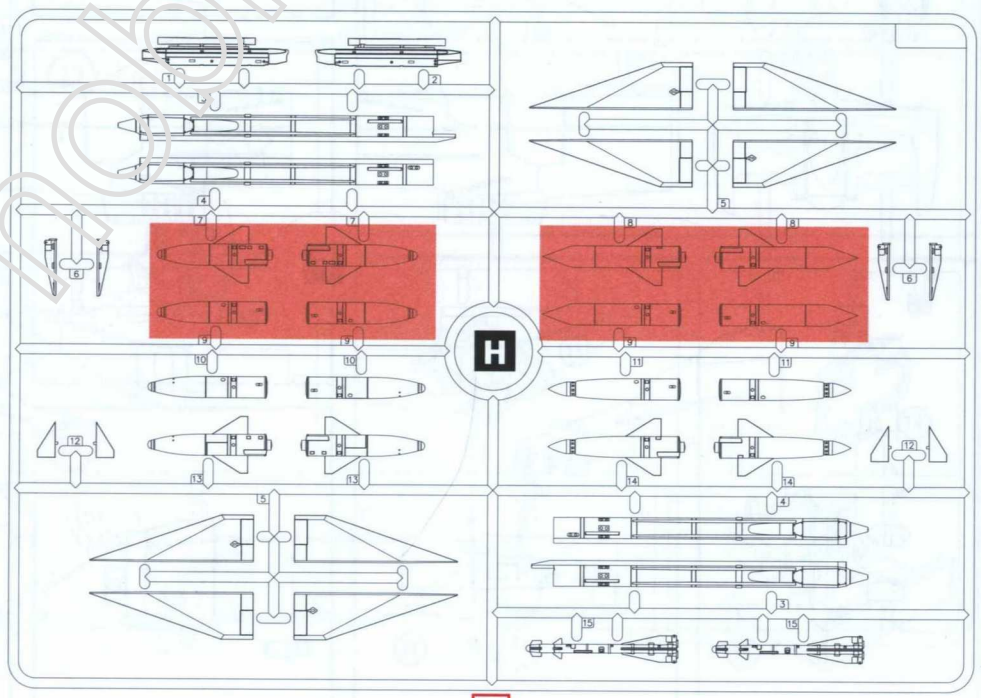
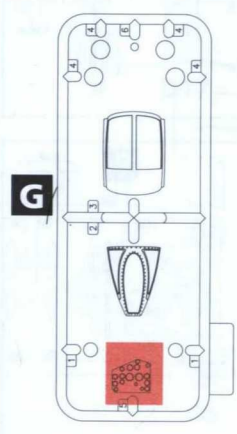
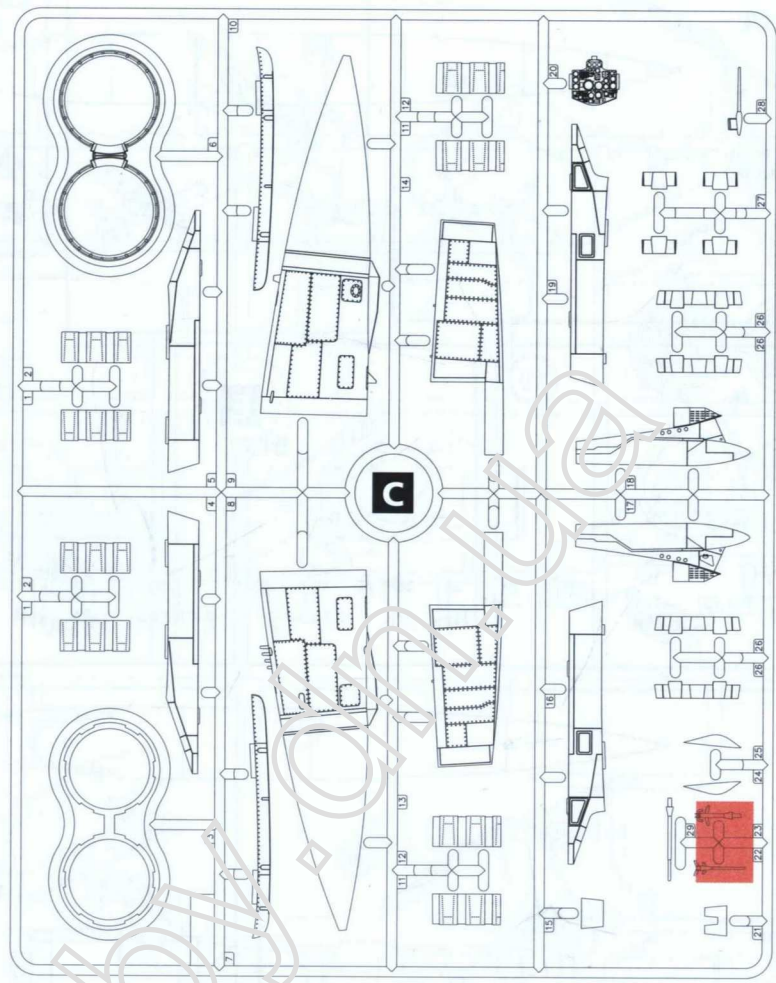

x2

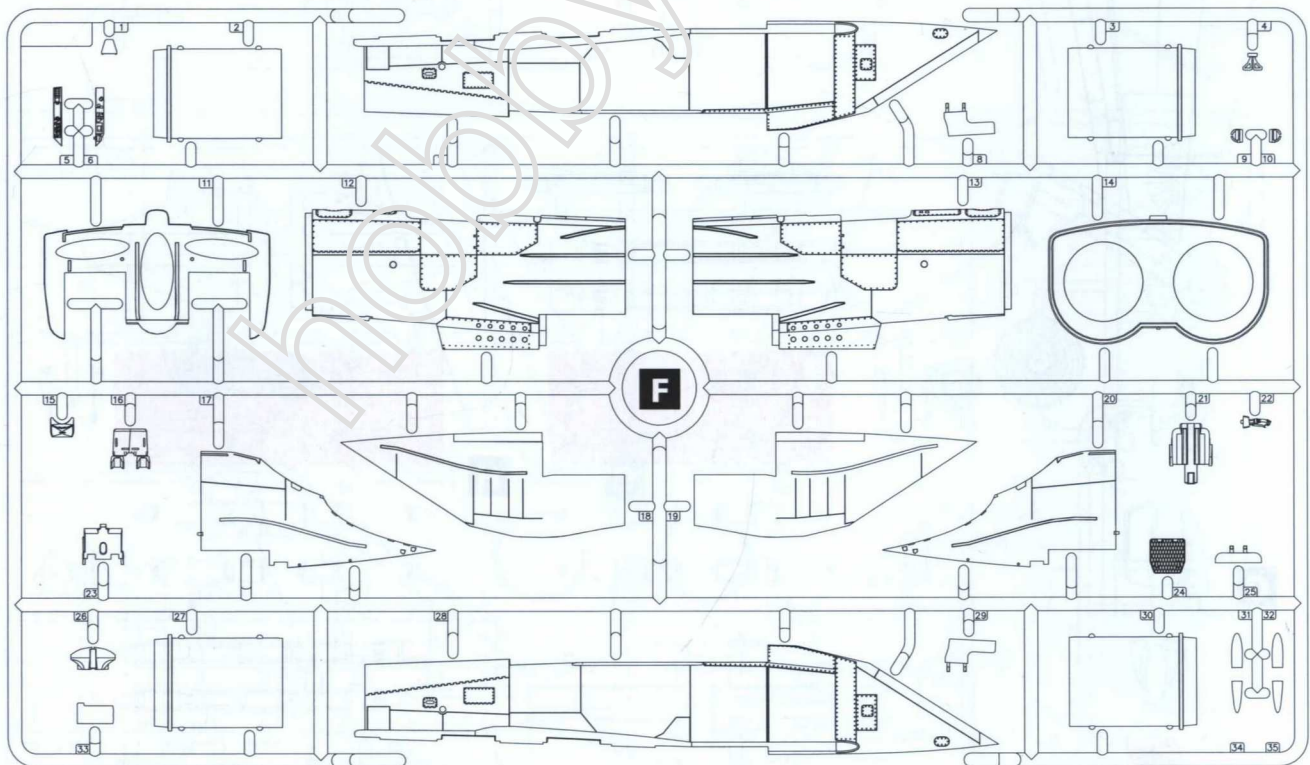
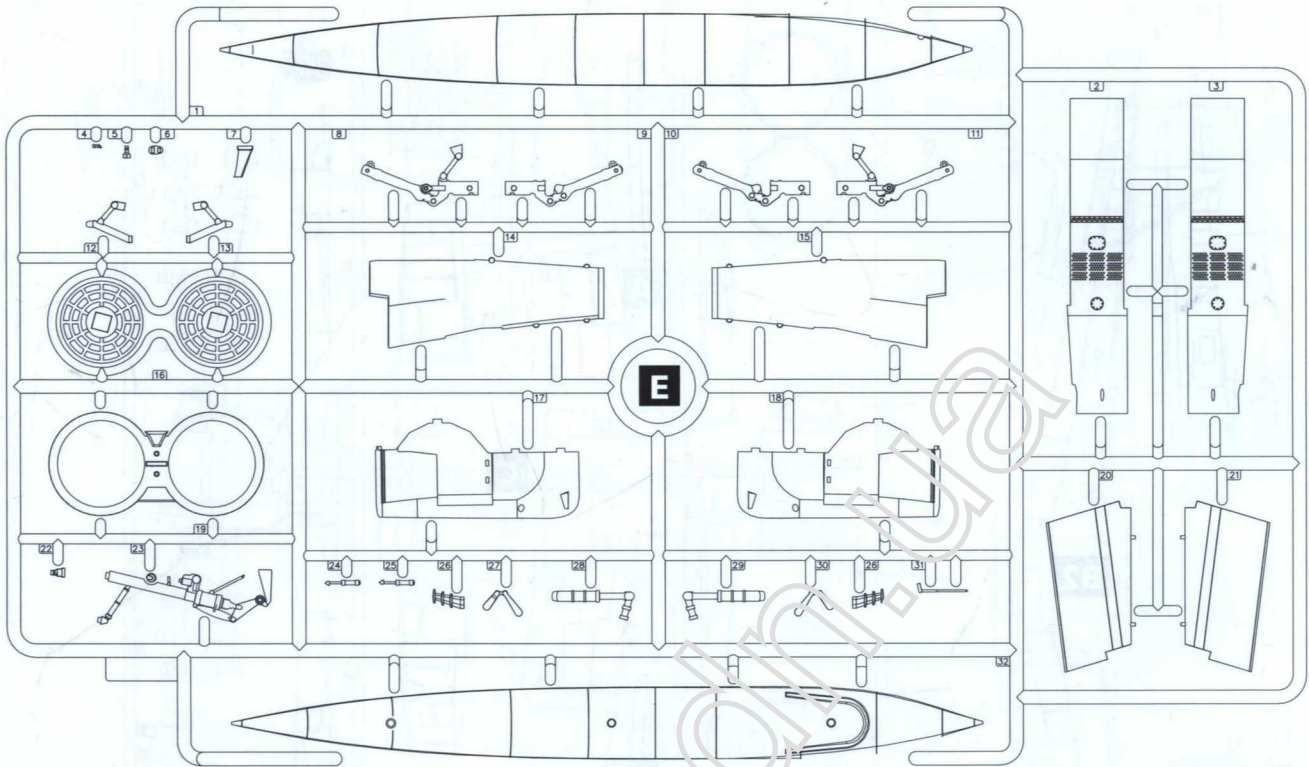

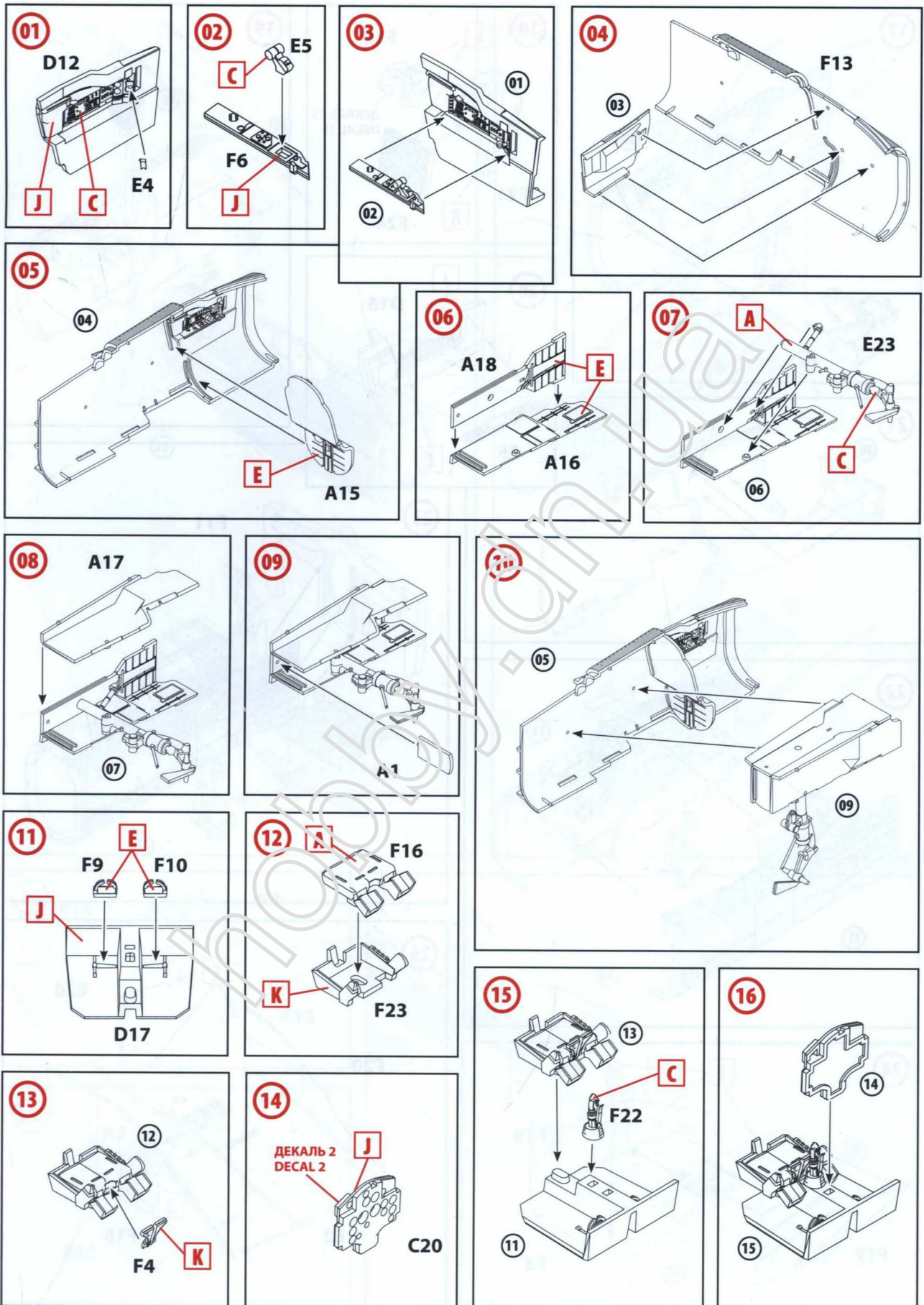

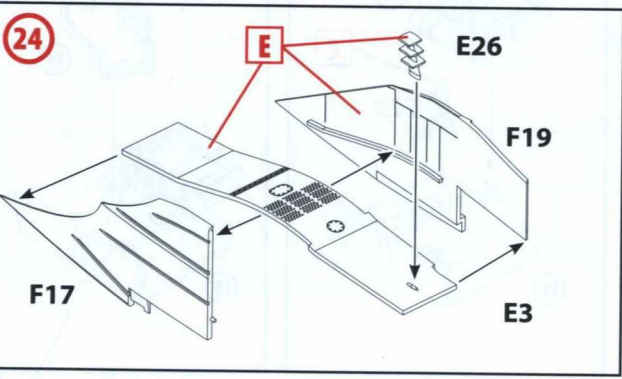
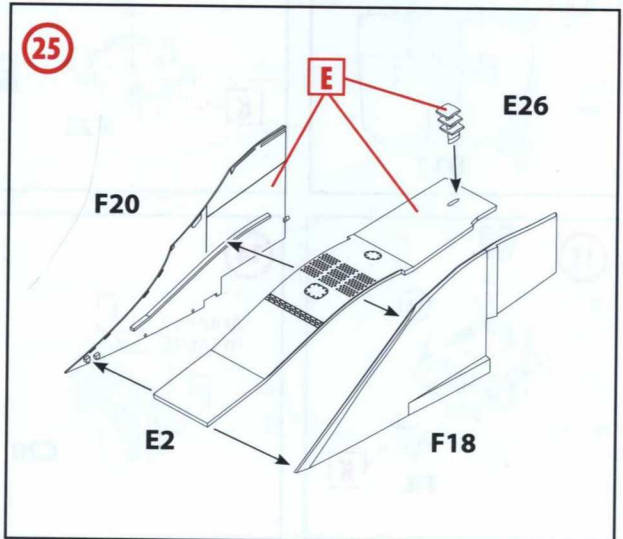
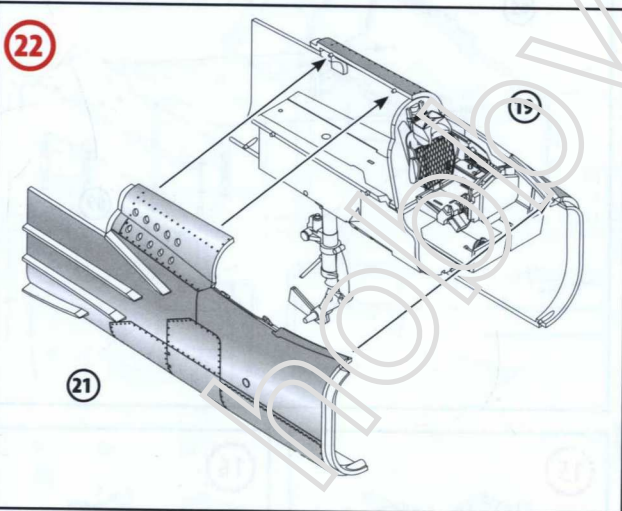
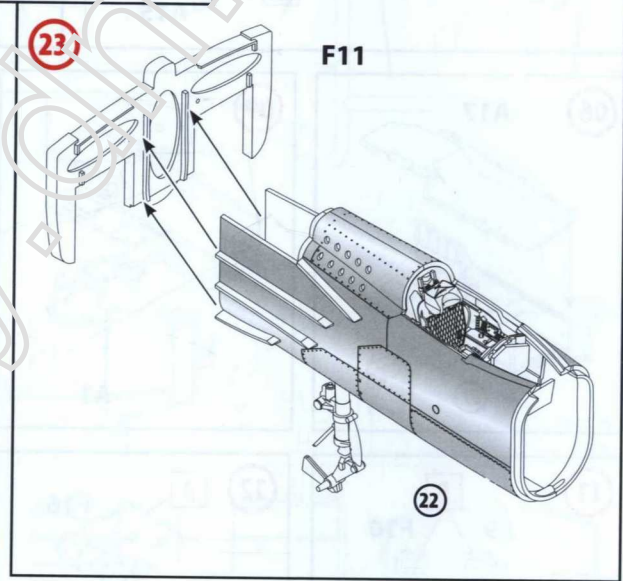
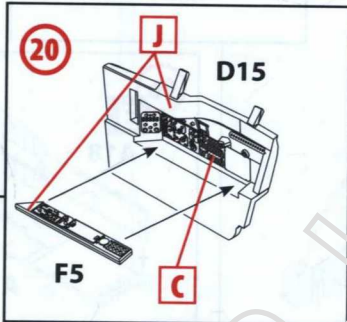
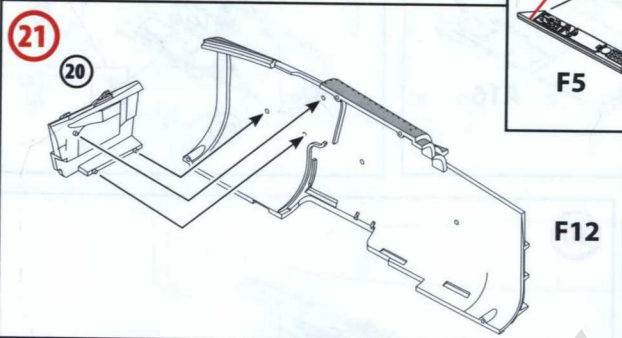
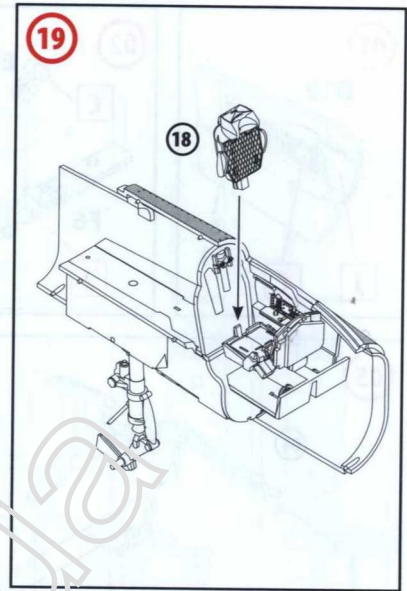
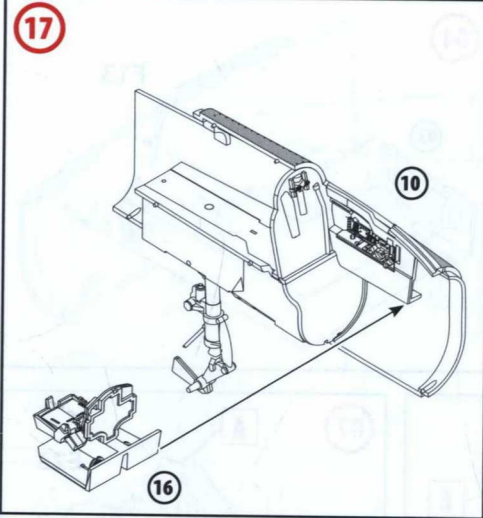

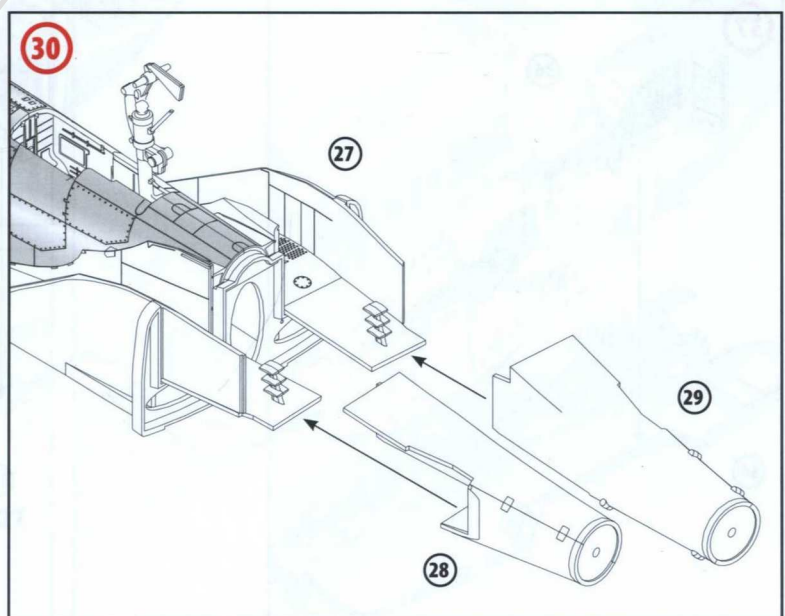
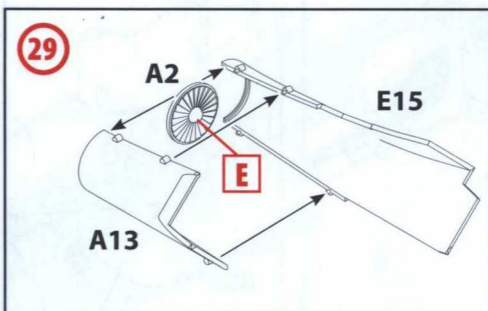
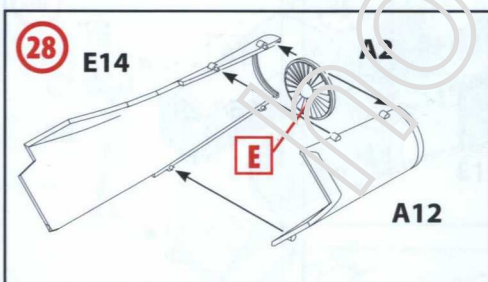
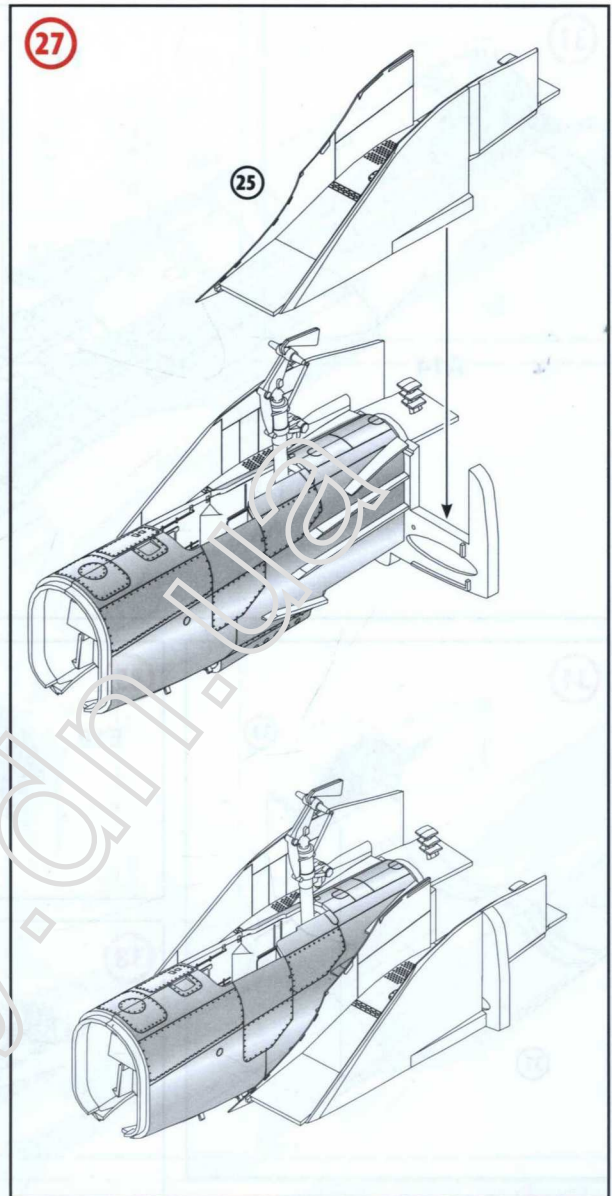
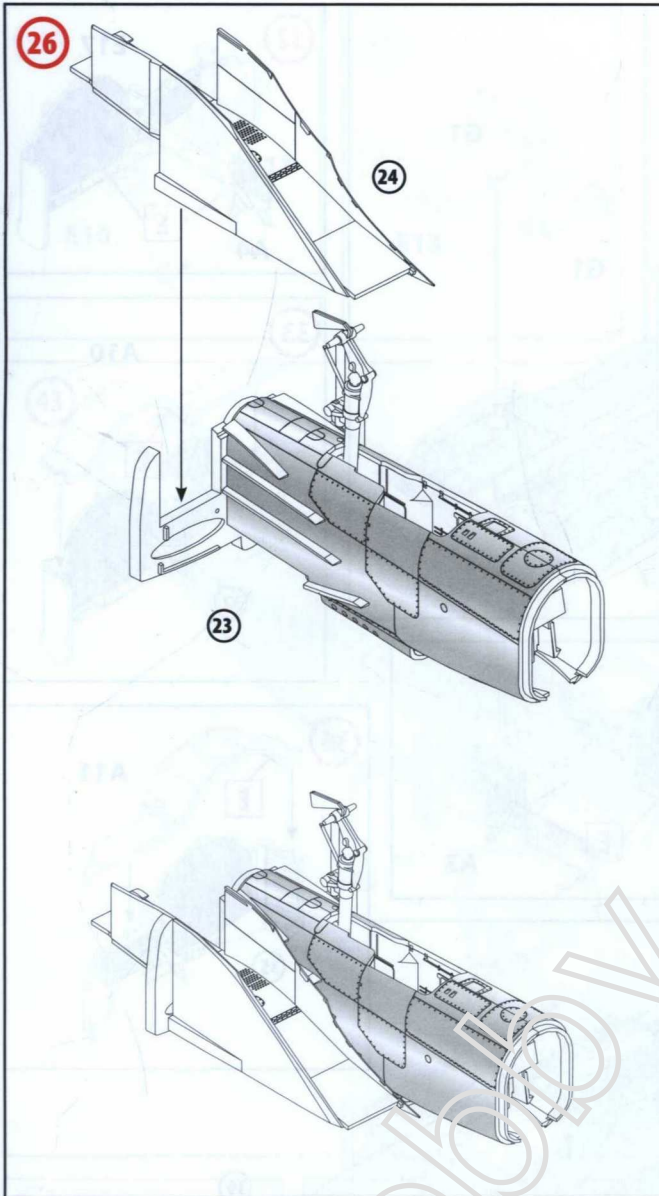

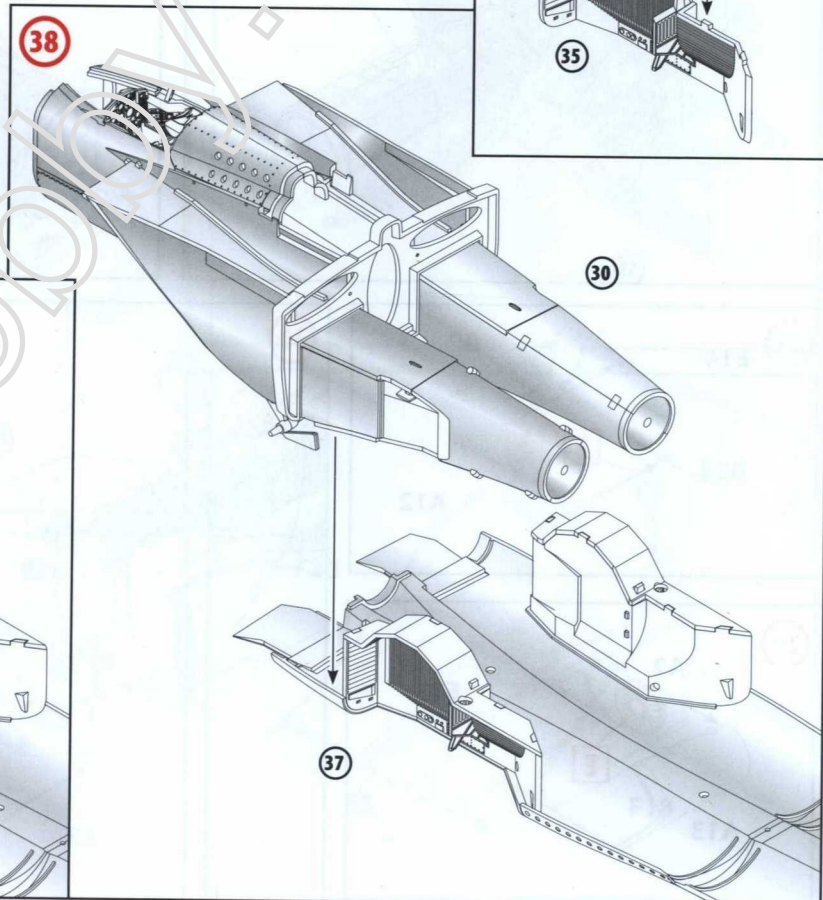
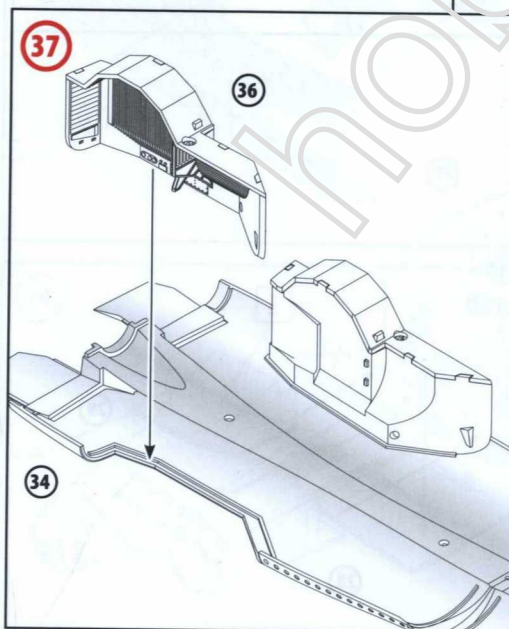
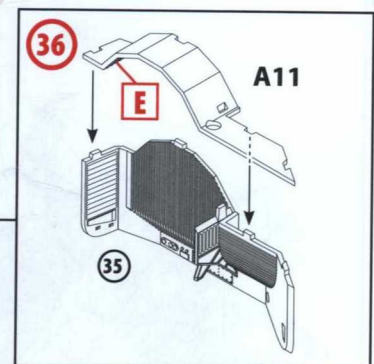
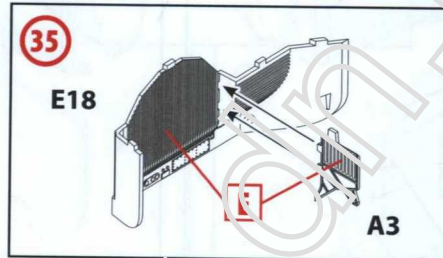
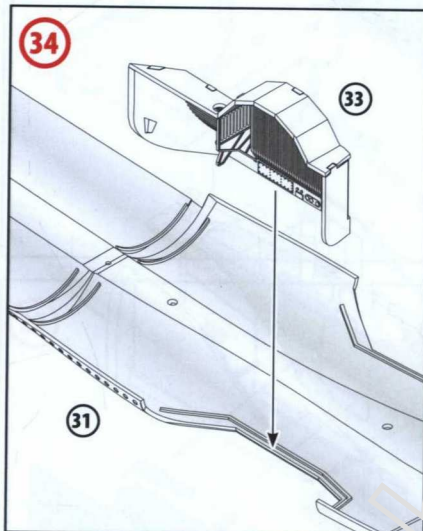
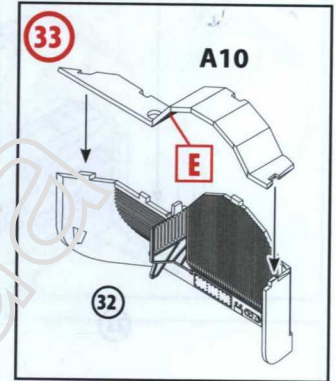
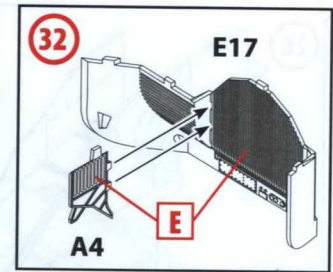
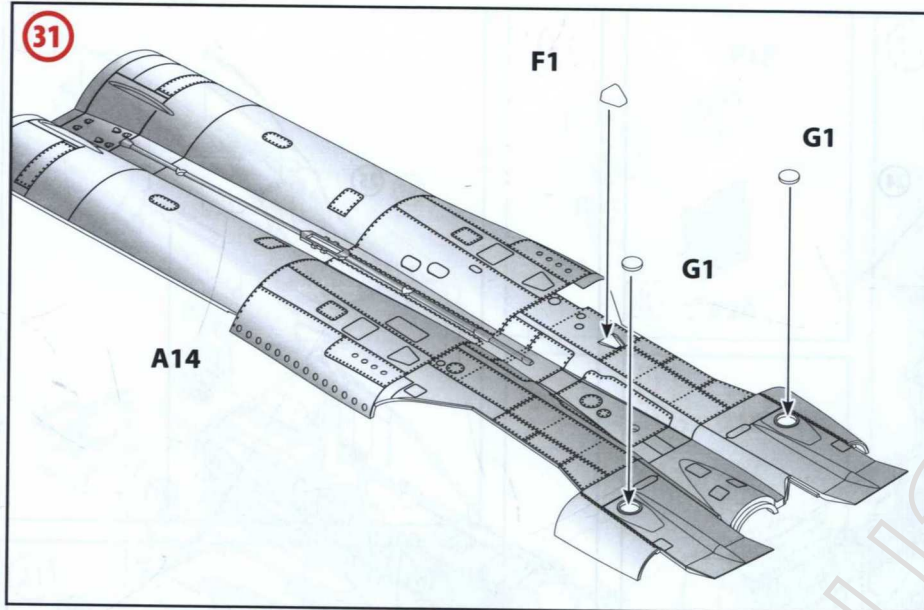

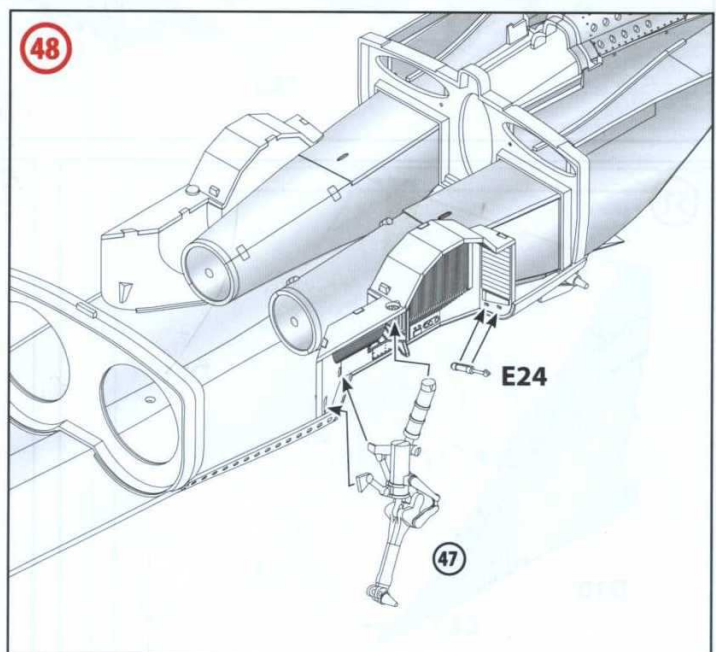
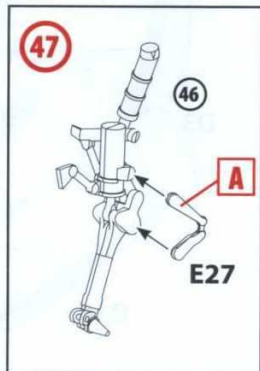
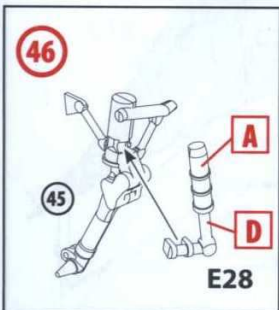
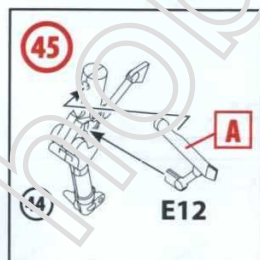
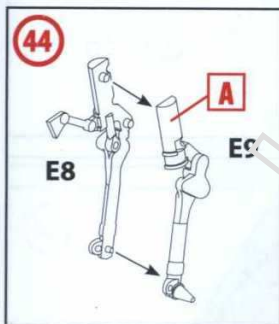
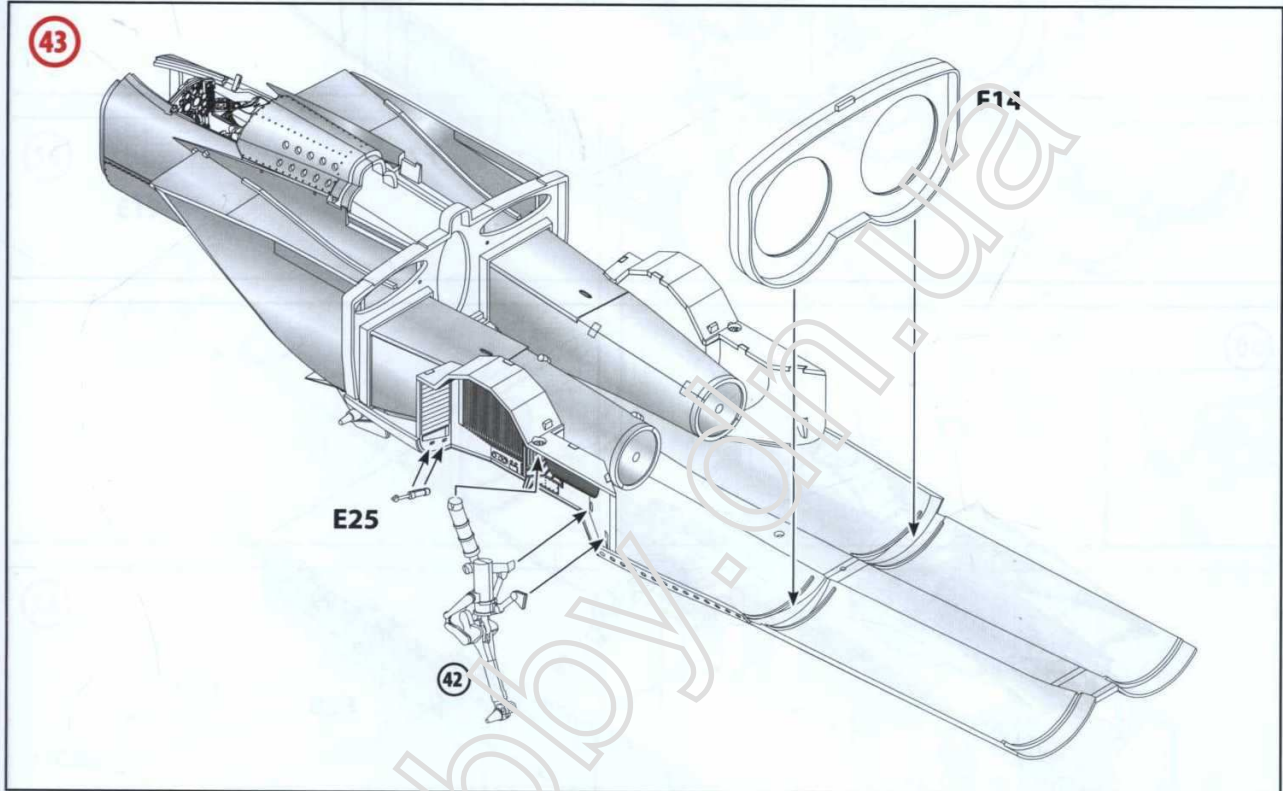
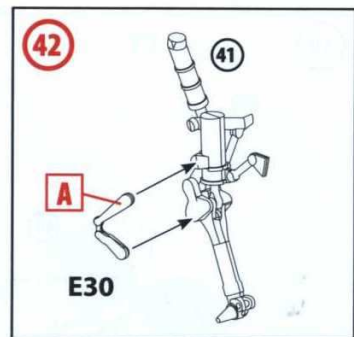
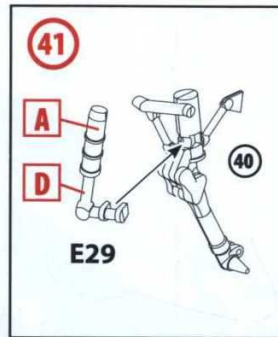
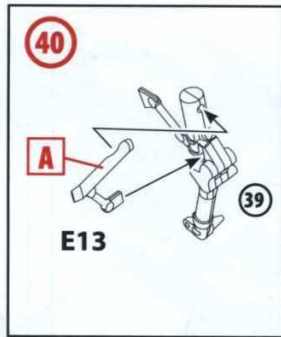
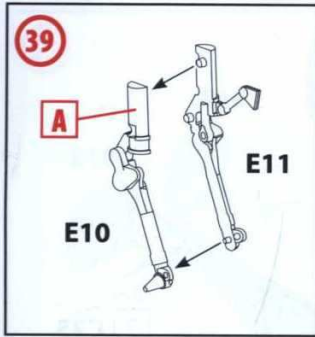

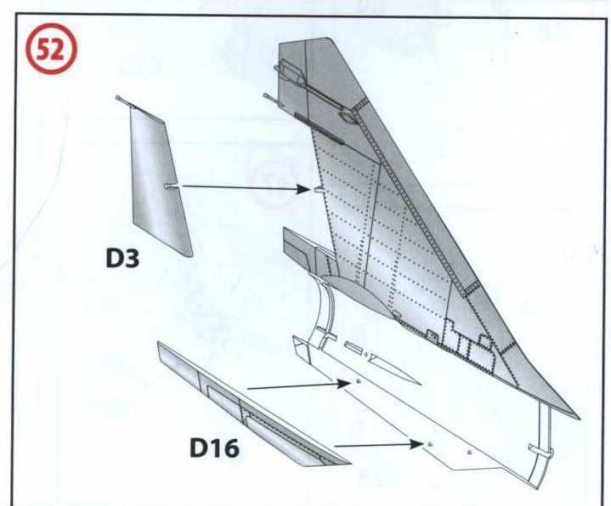
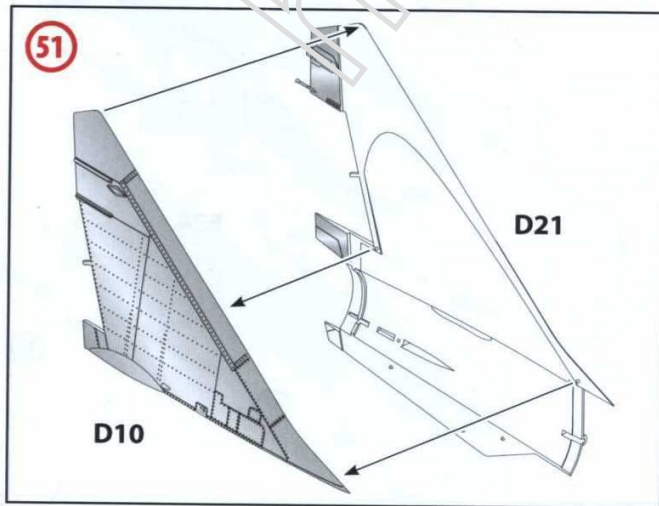
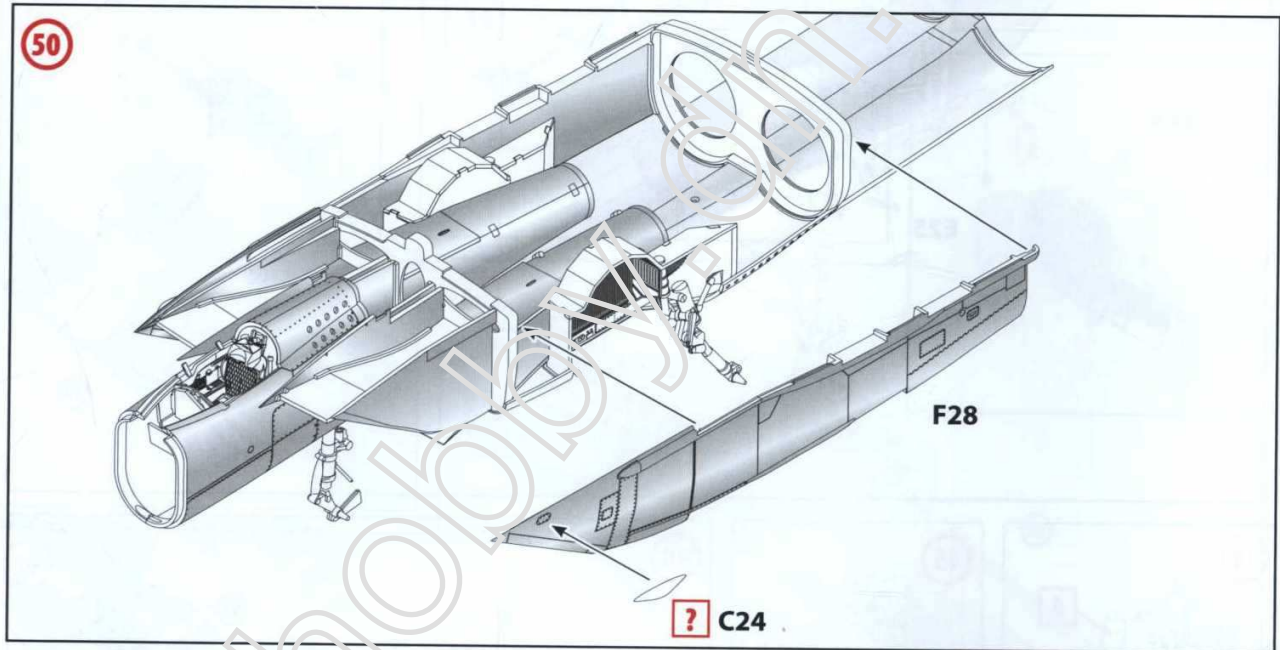
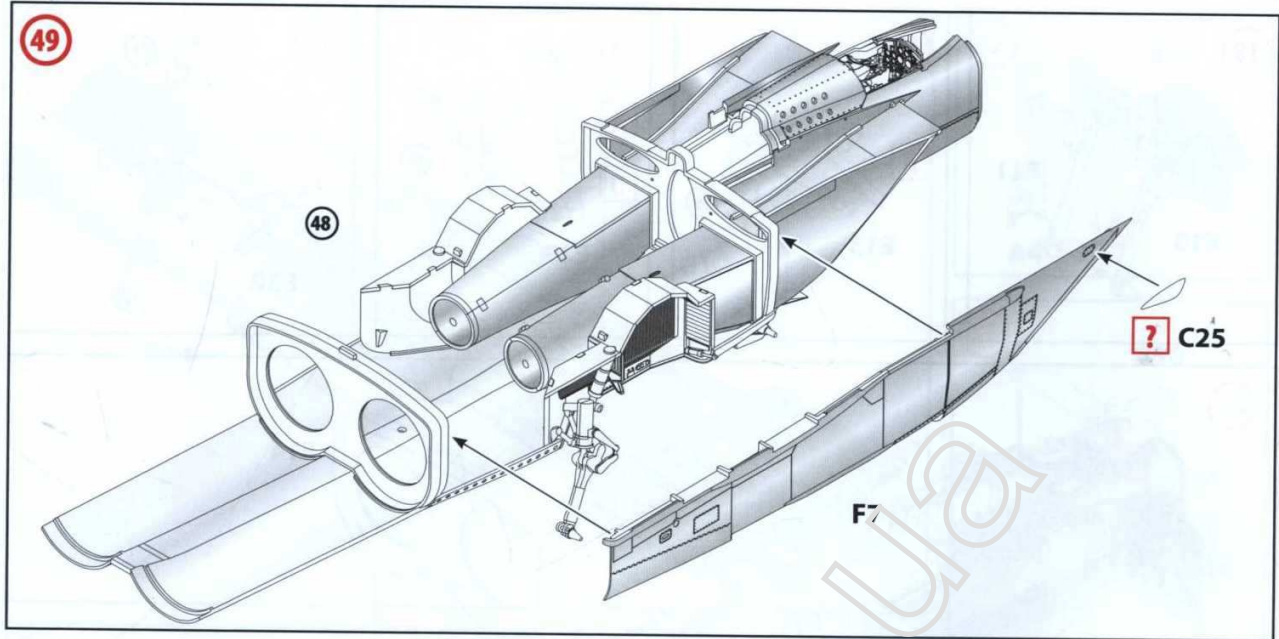

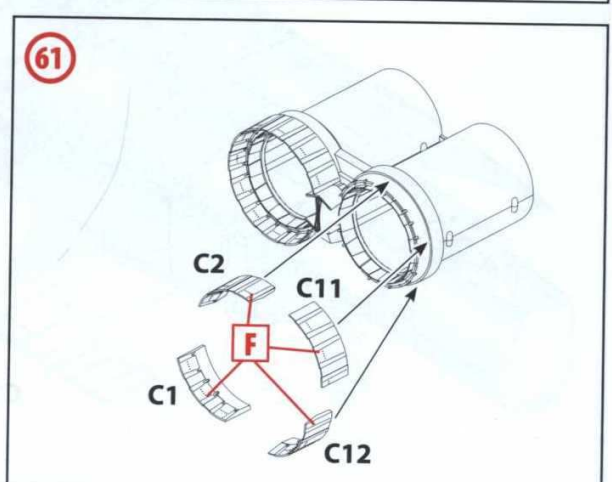
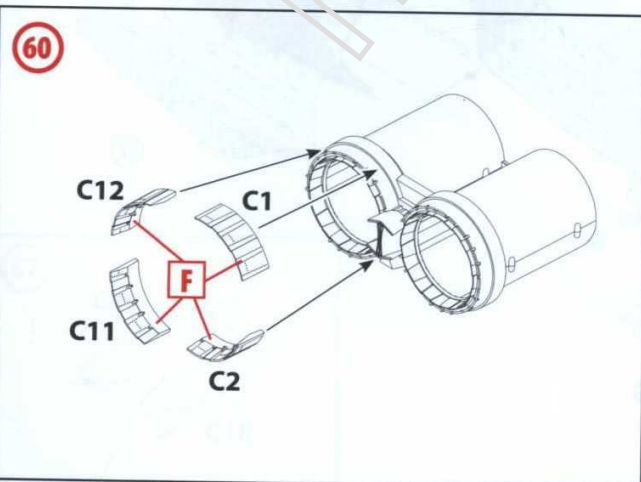
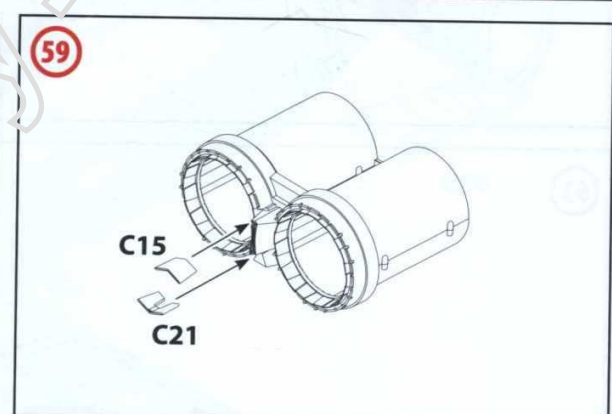
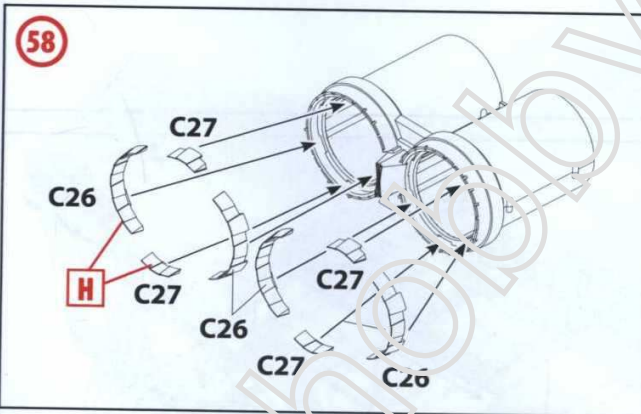
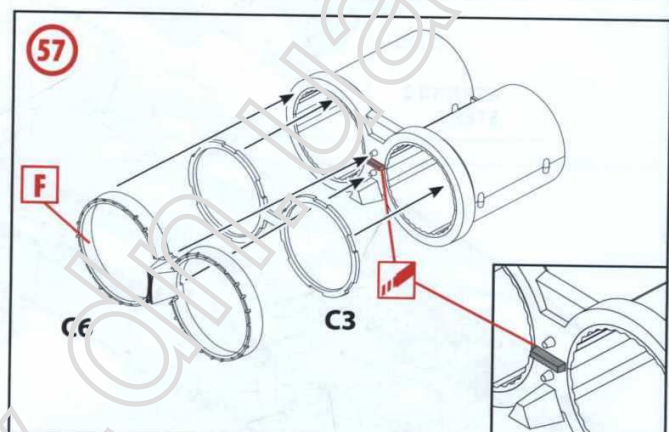
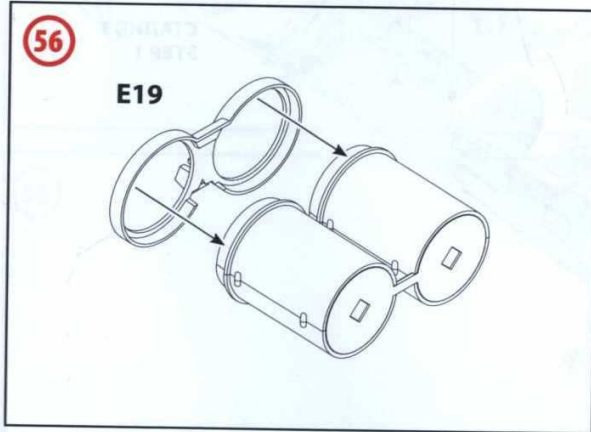
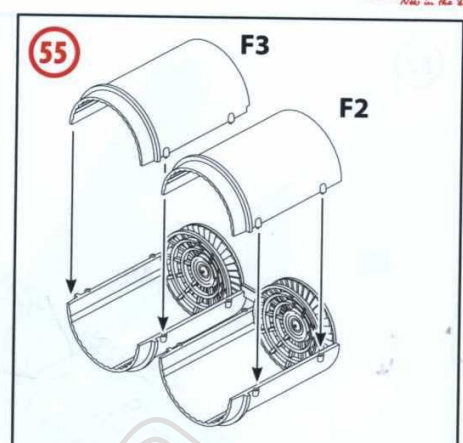
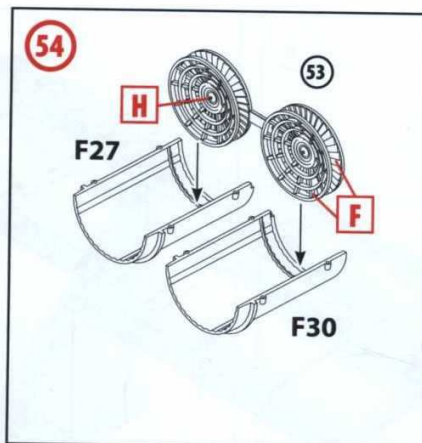
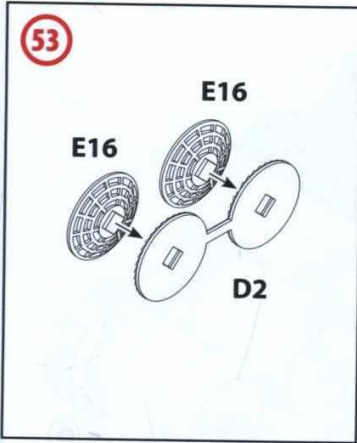

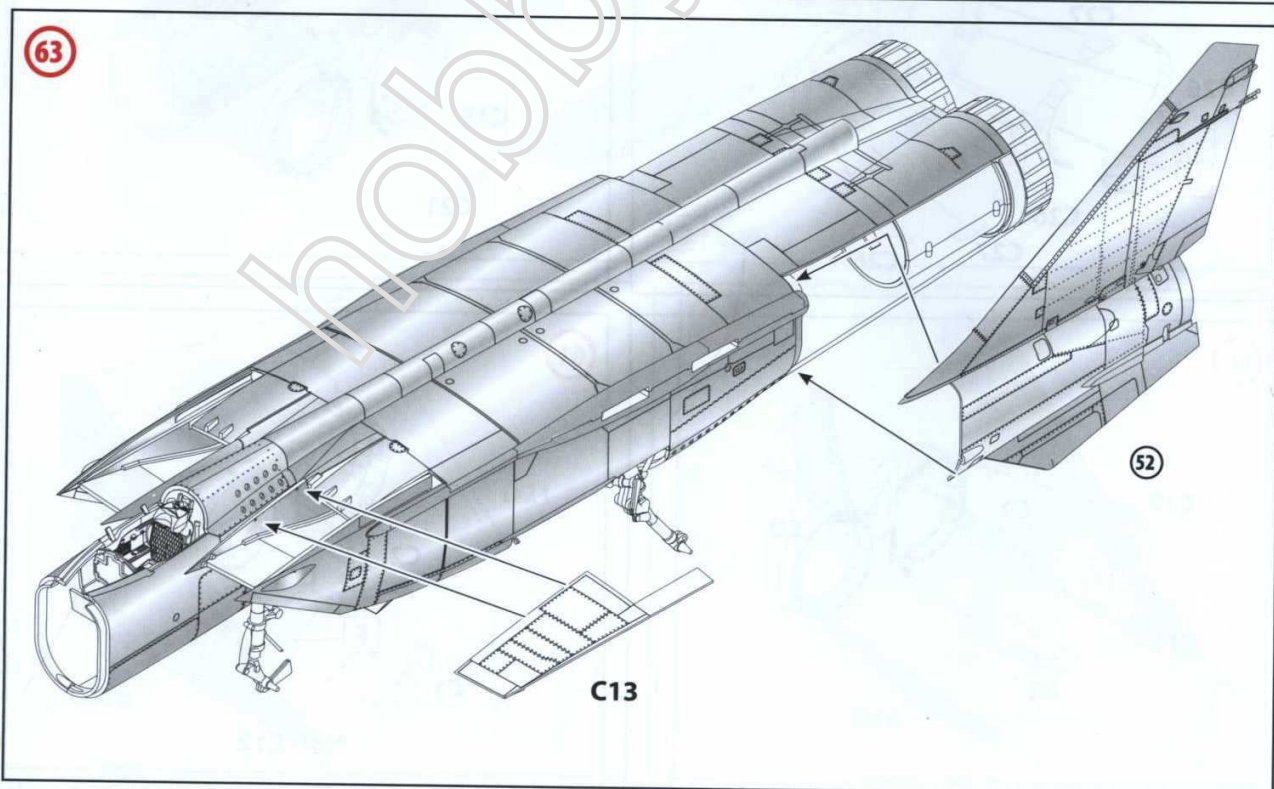
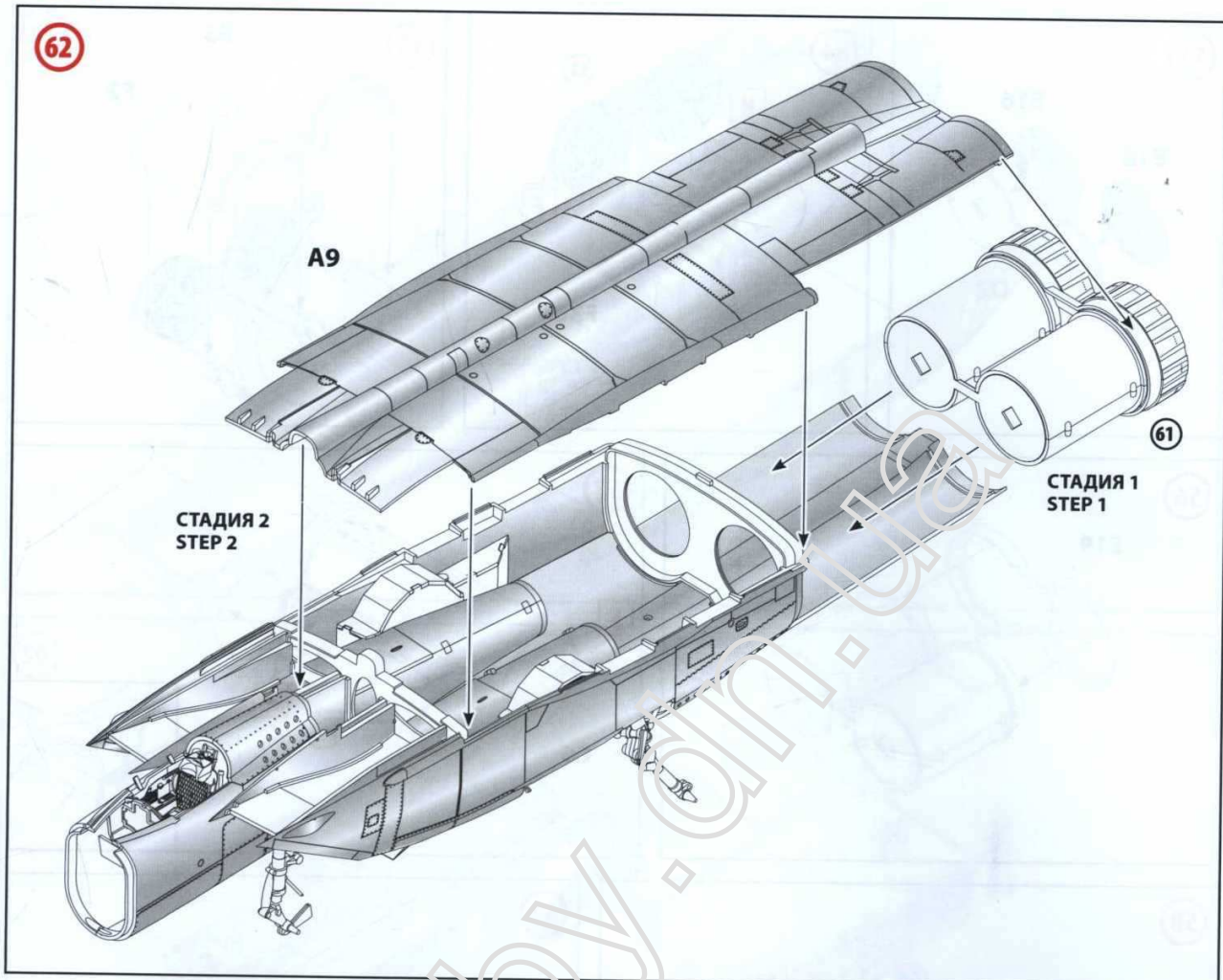

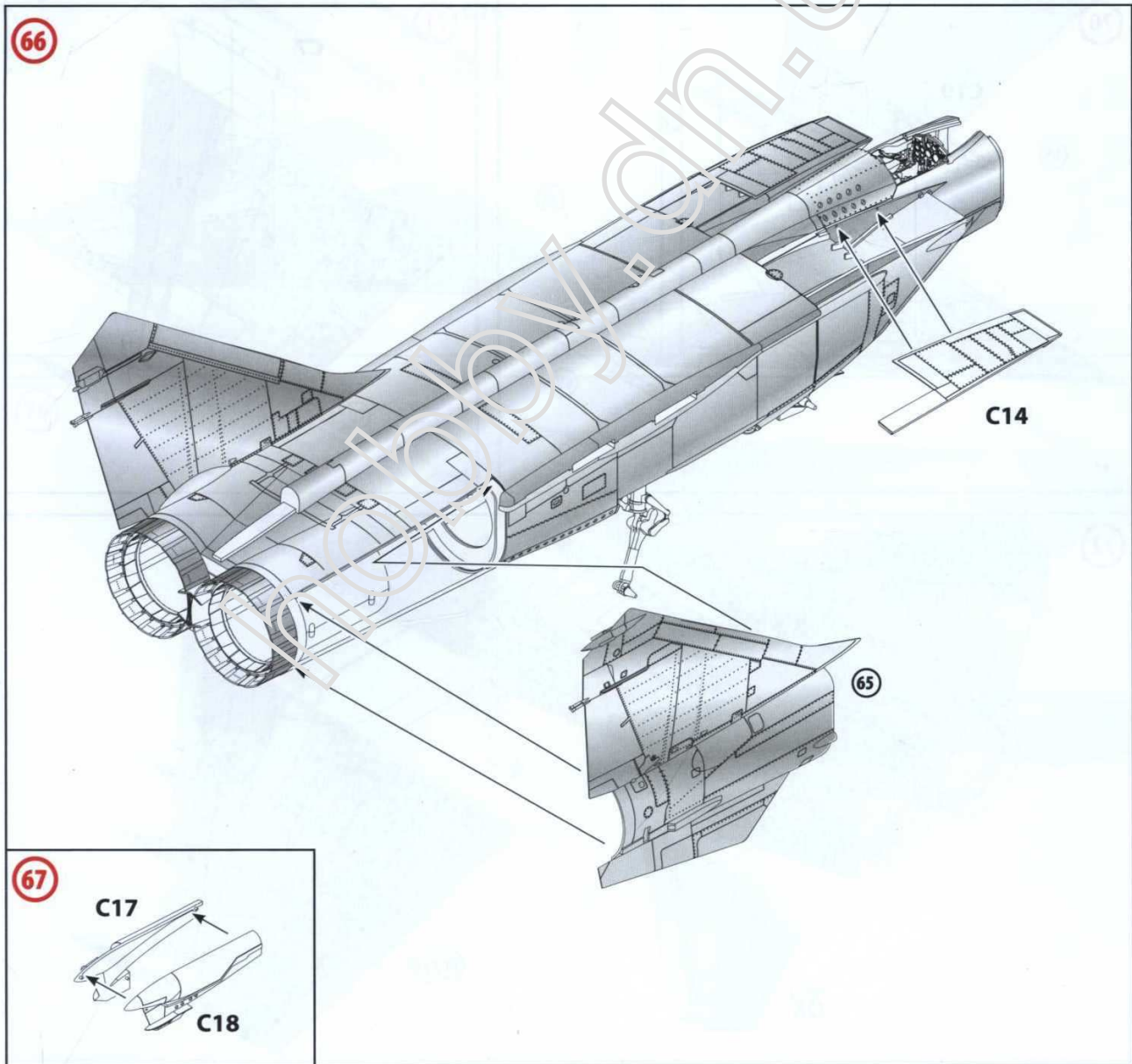
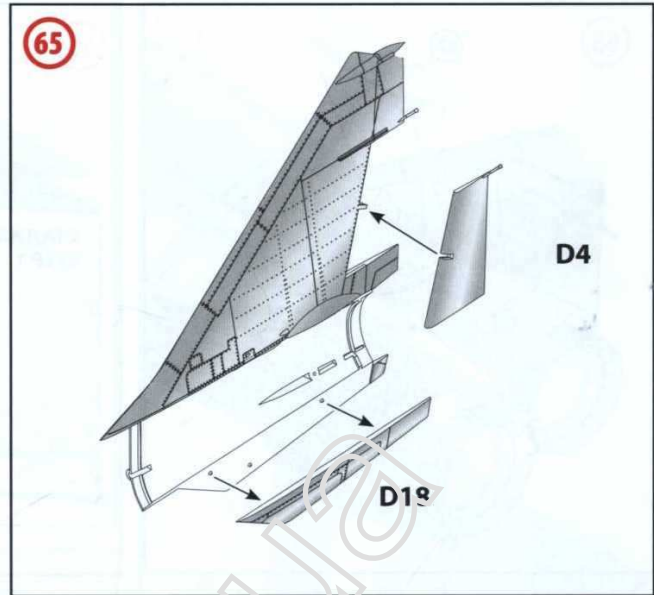
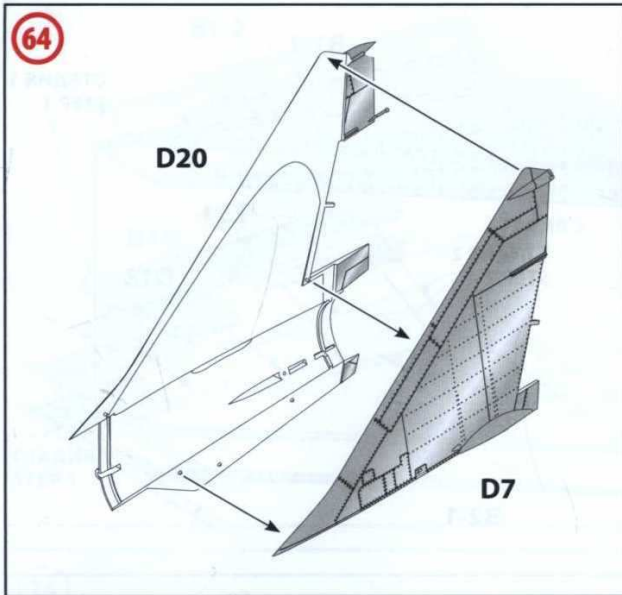

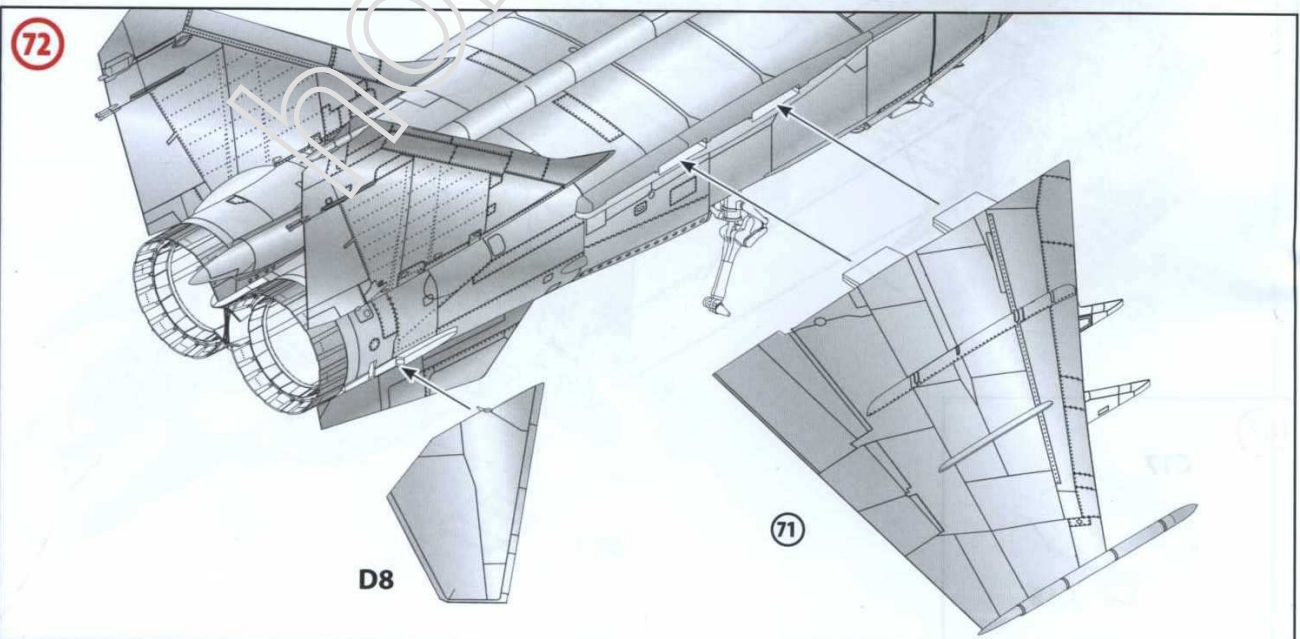
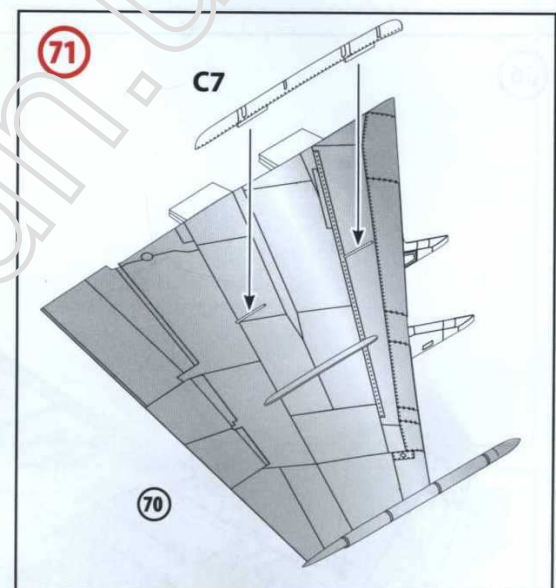
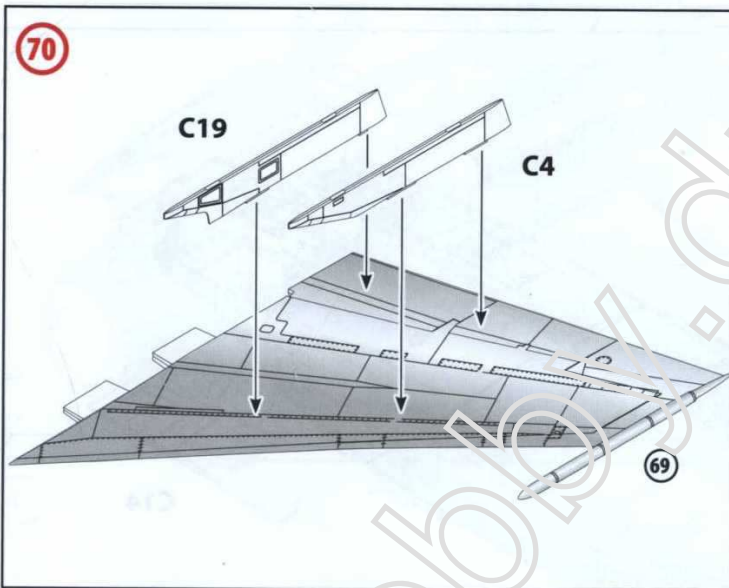
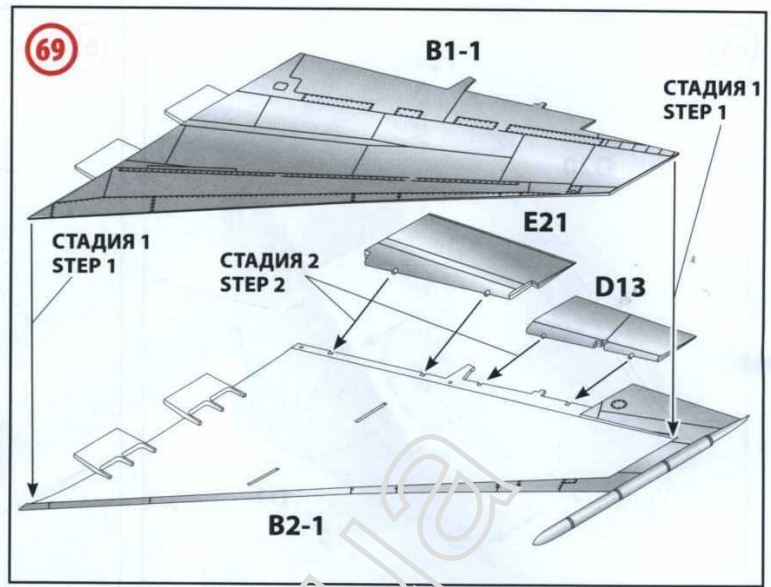
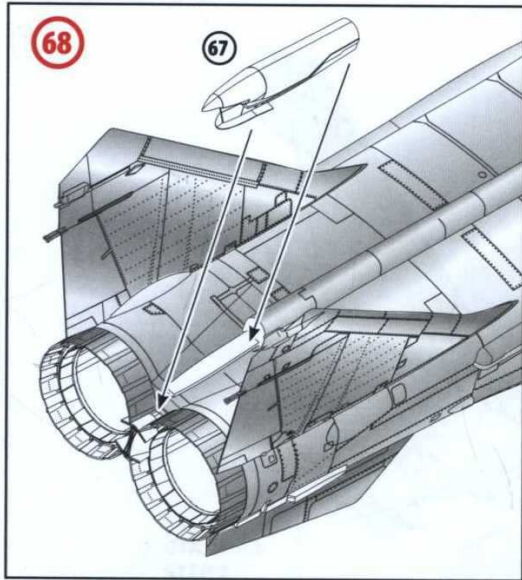

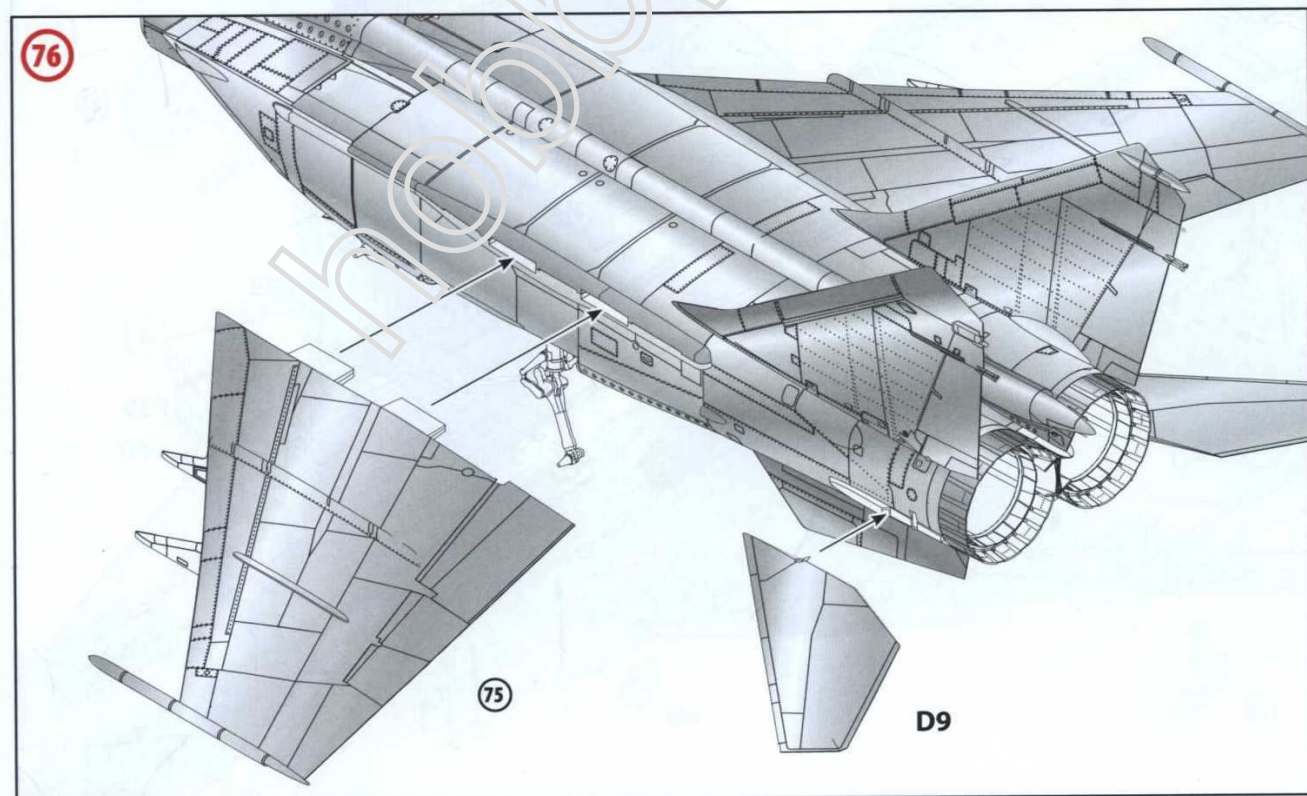
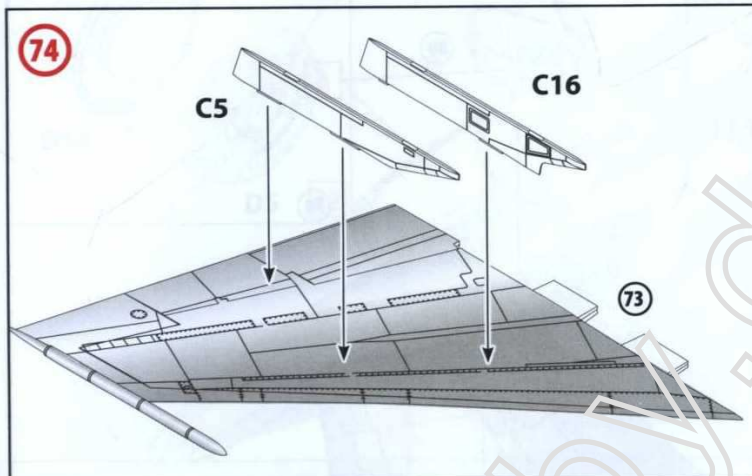
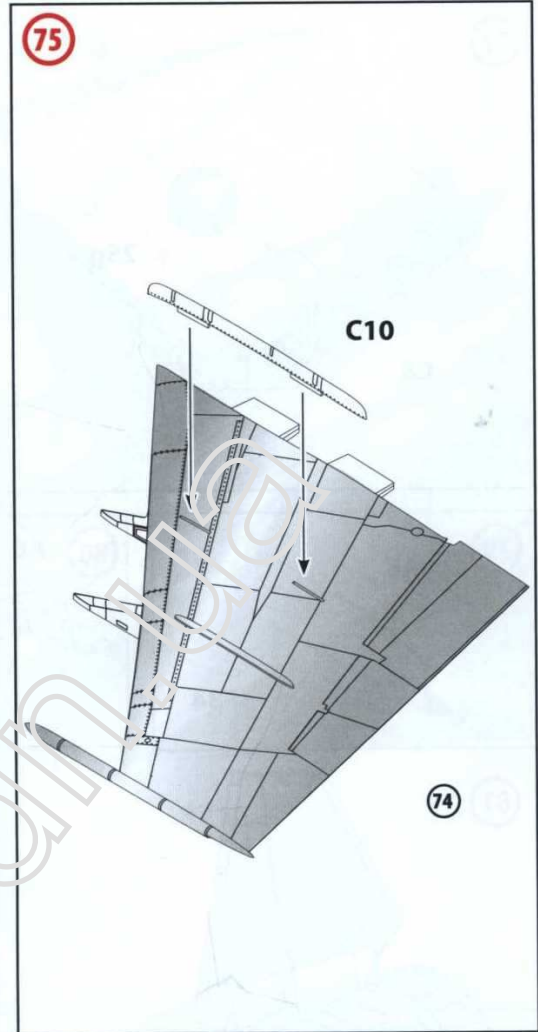
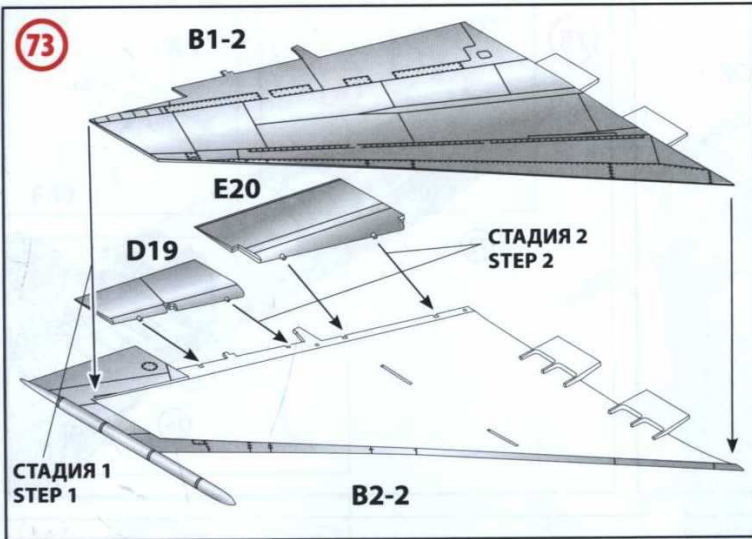

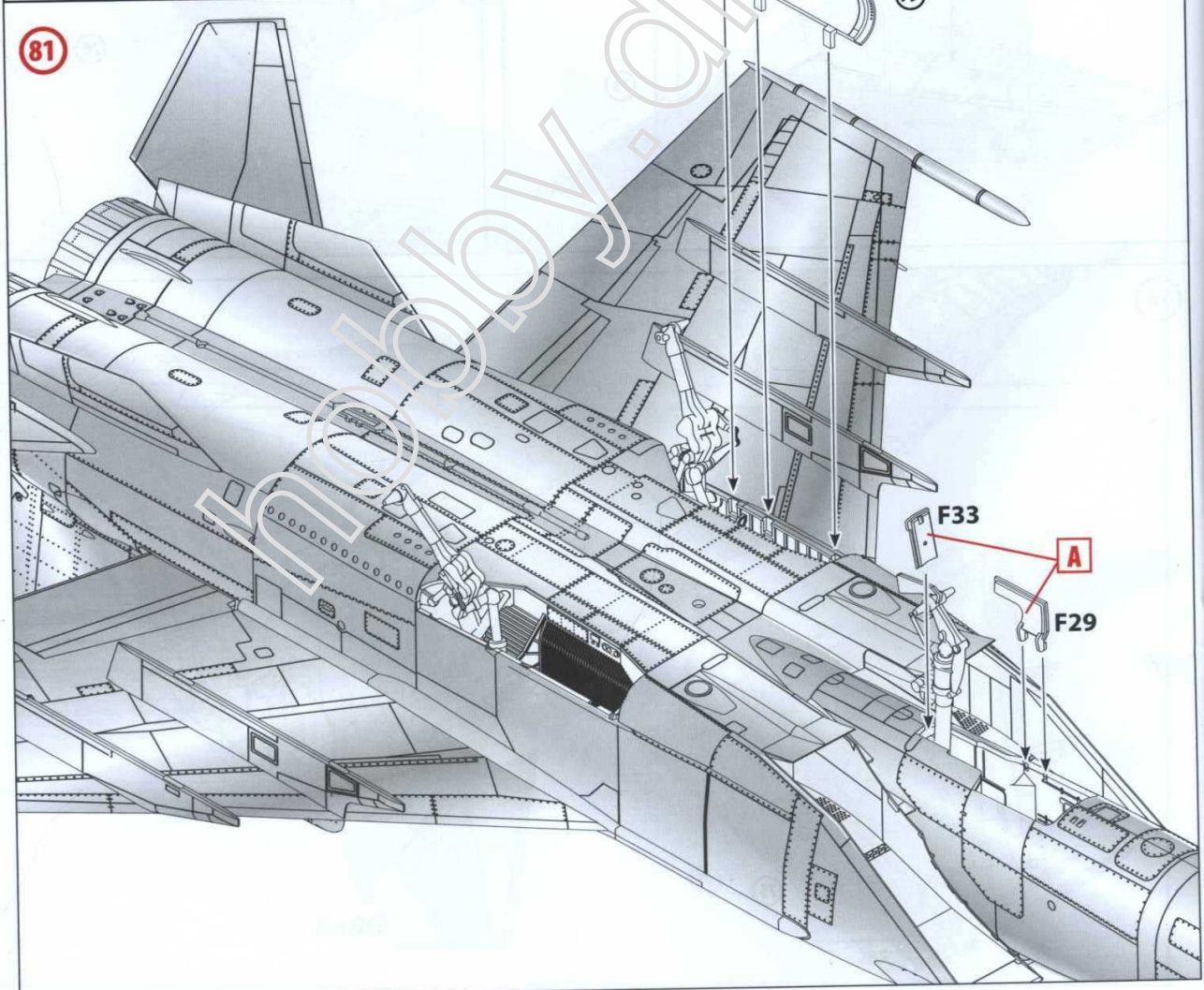
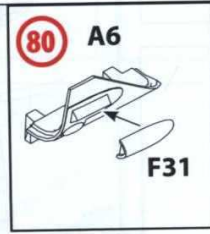
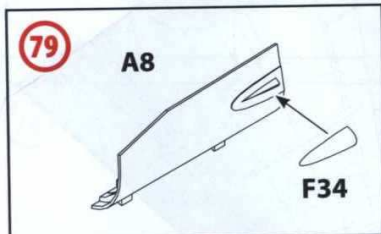
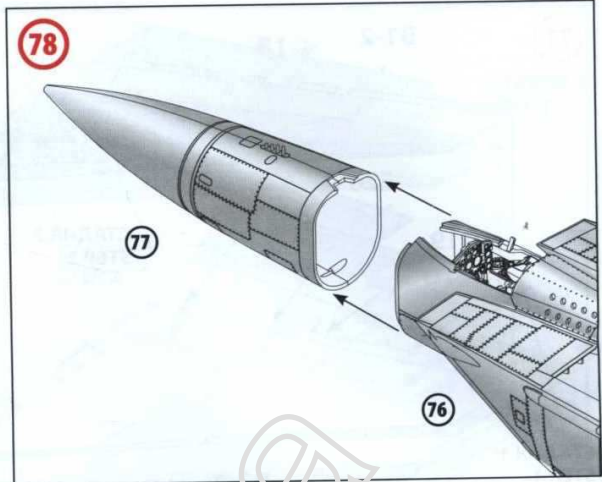
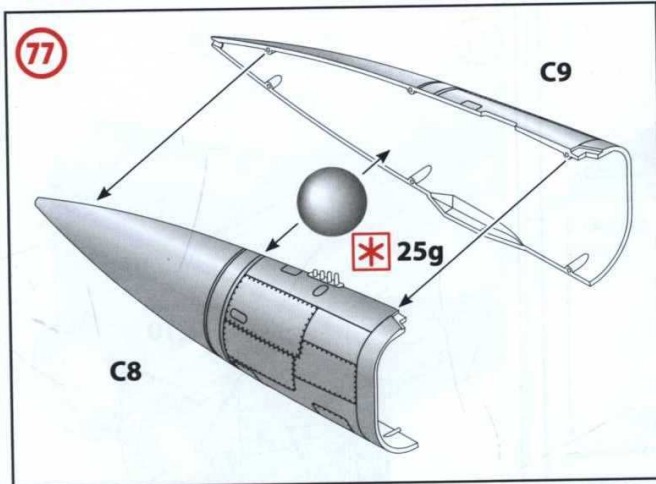

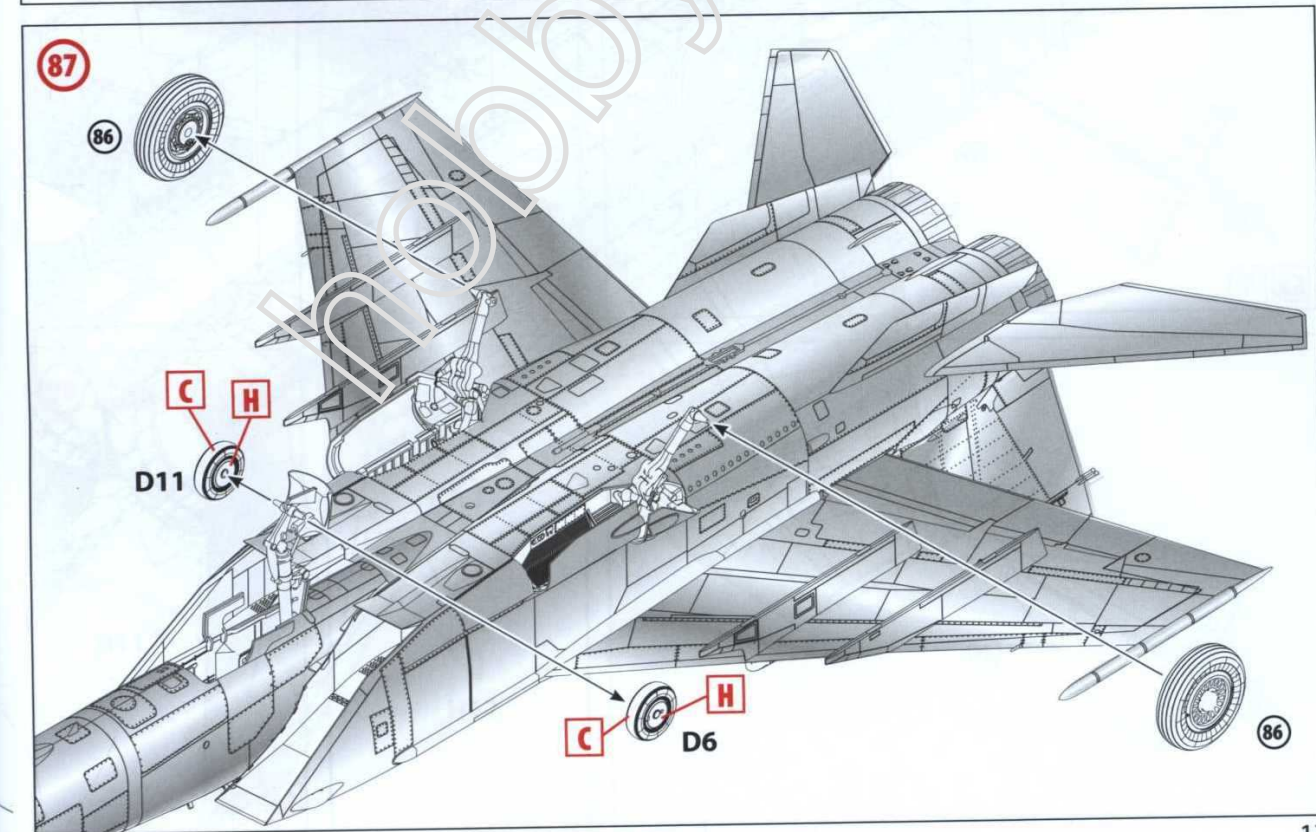
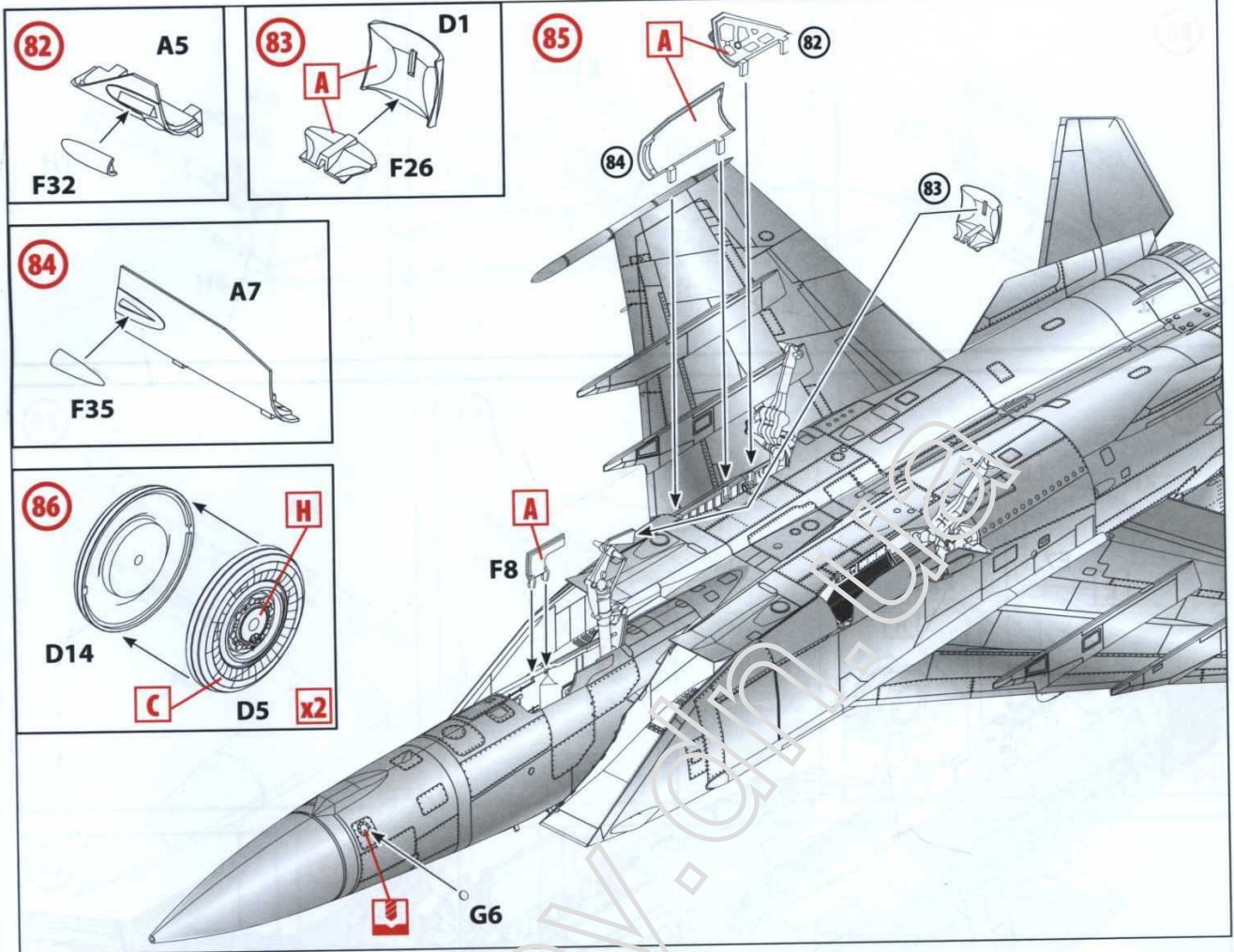

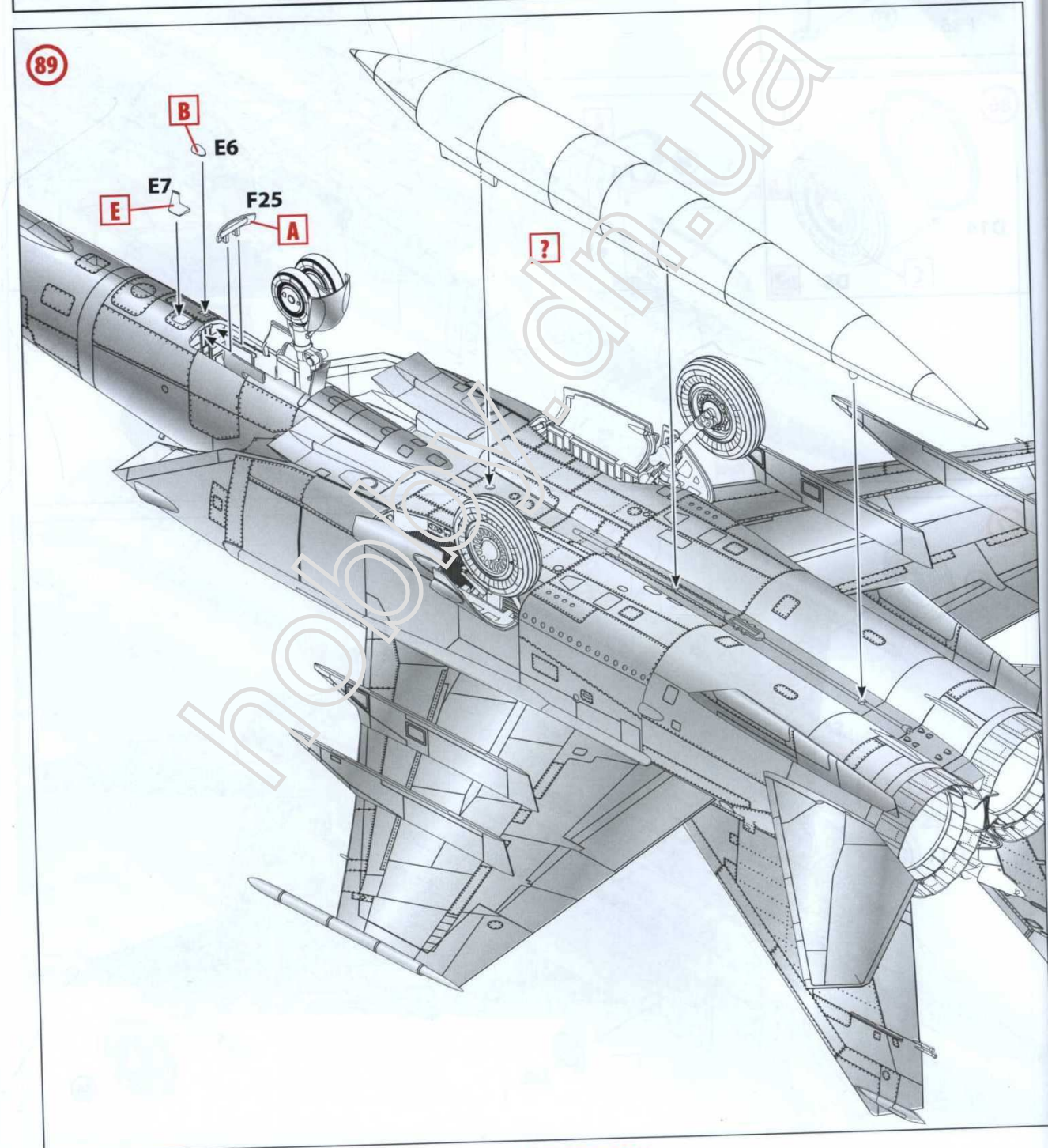
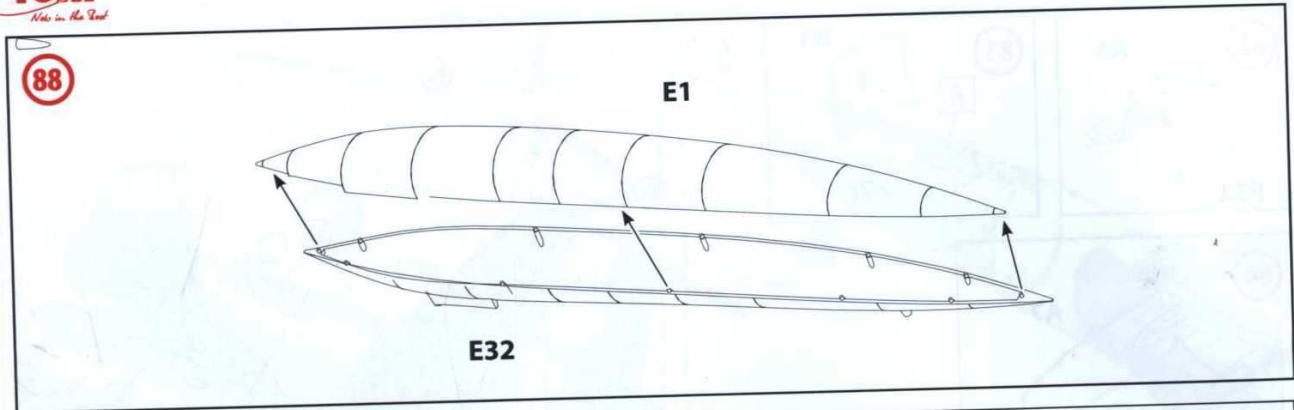

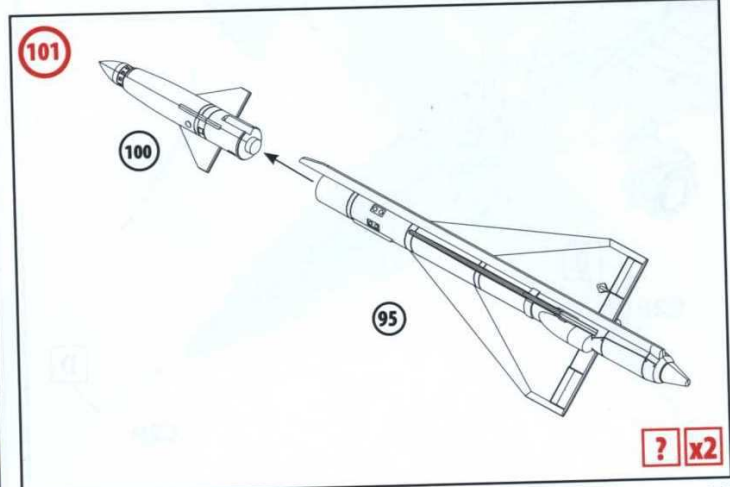
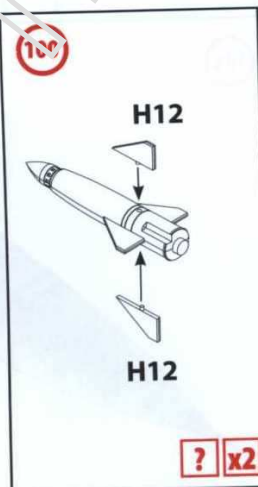
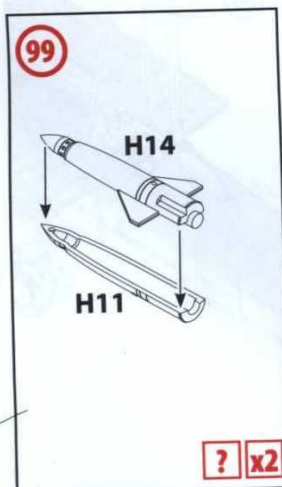
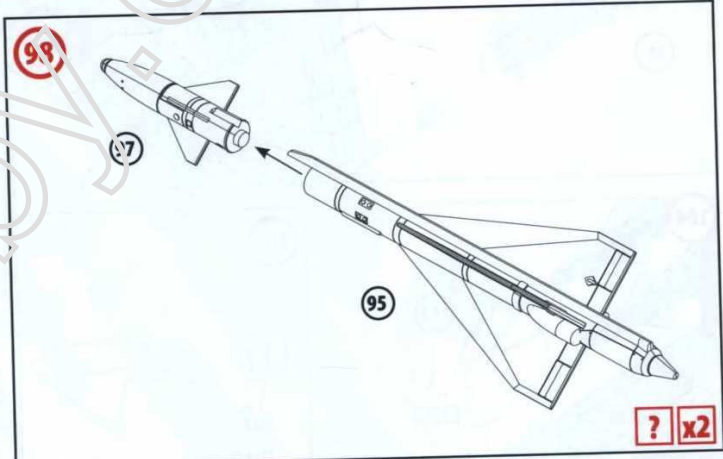
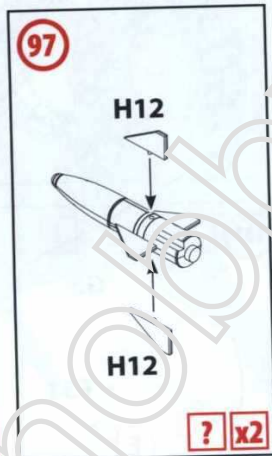
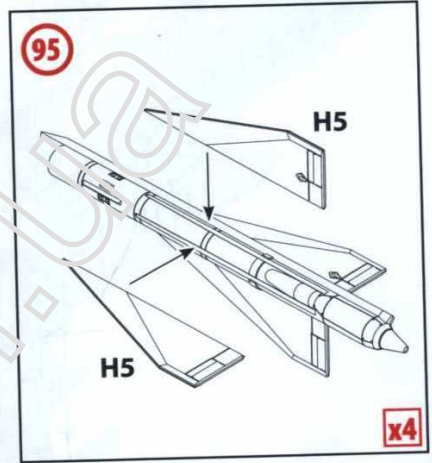
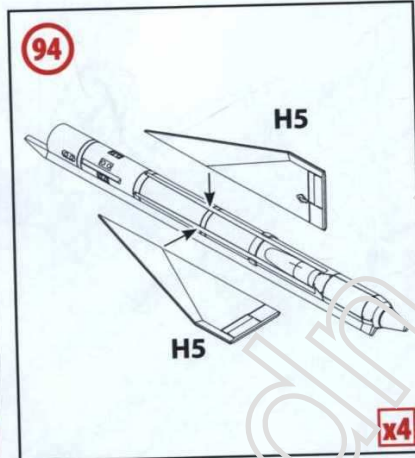
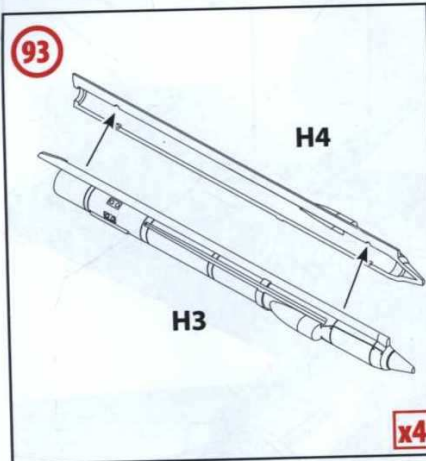
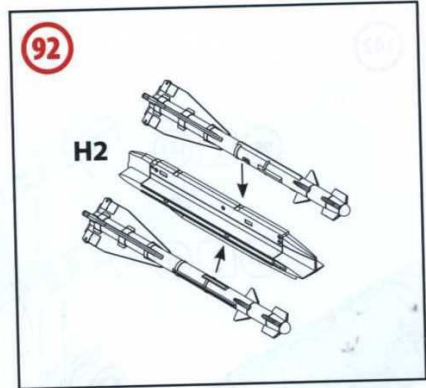
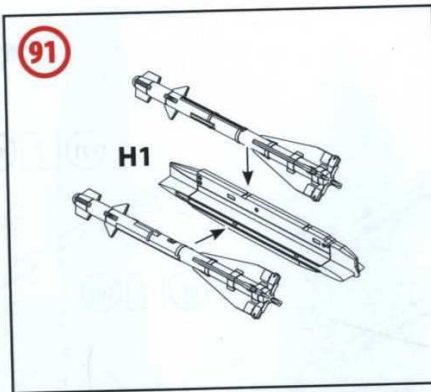
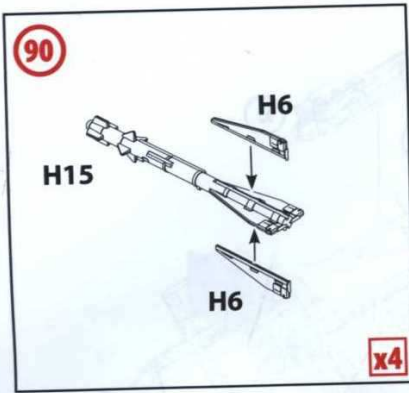

102

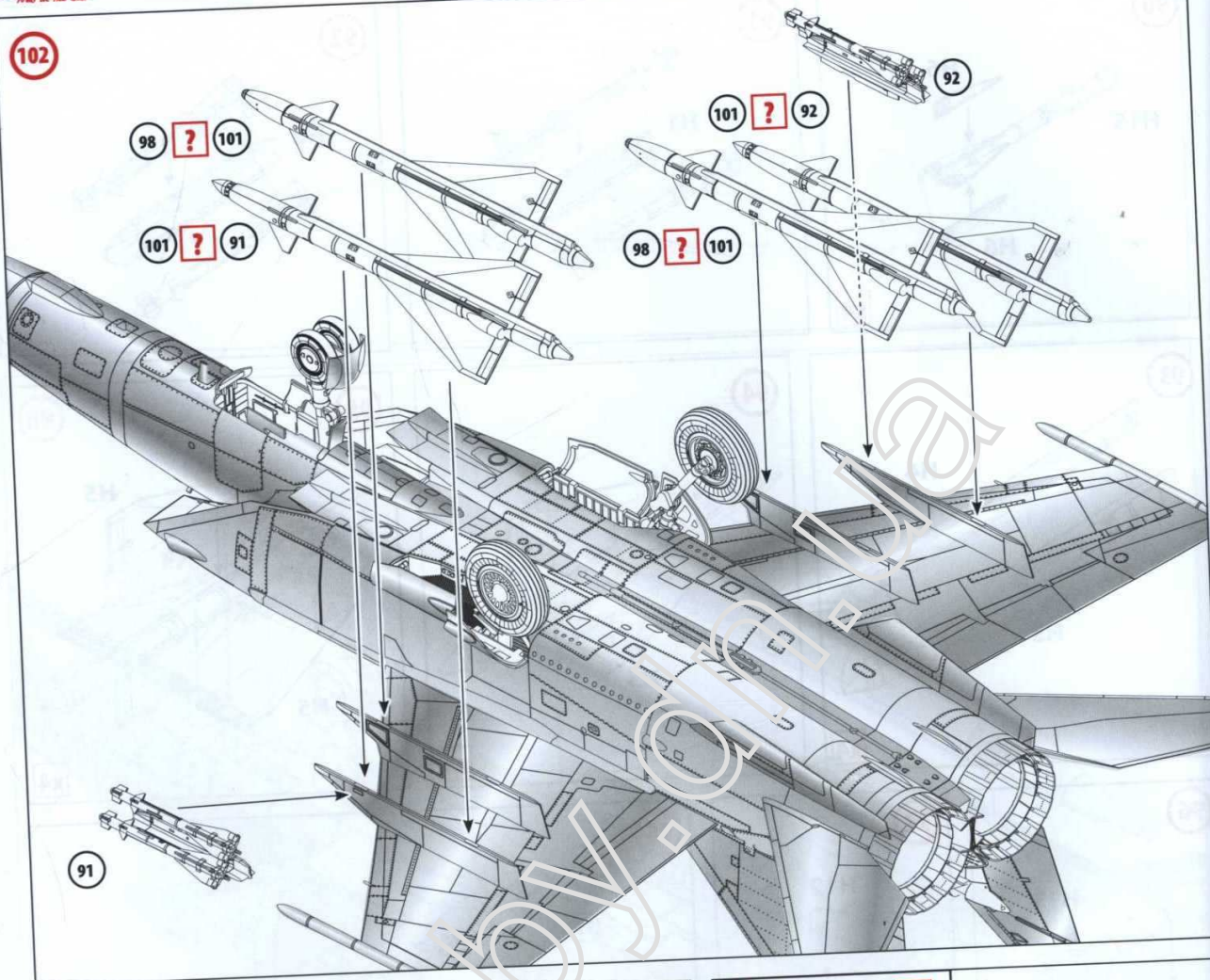

104

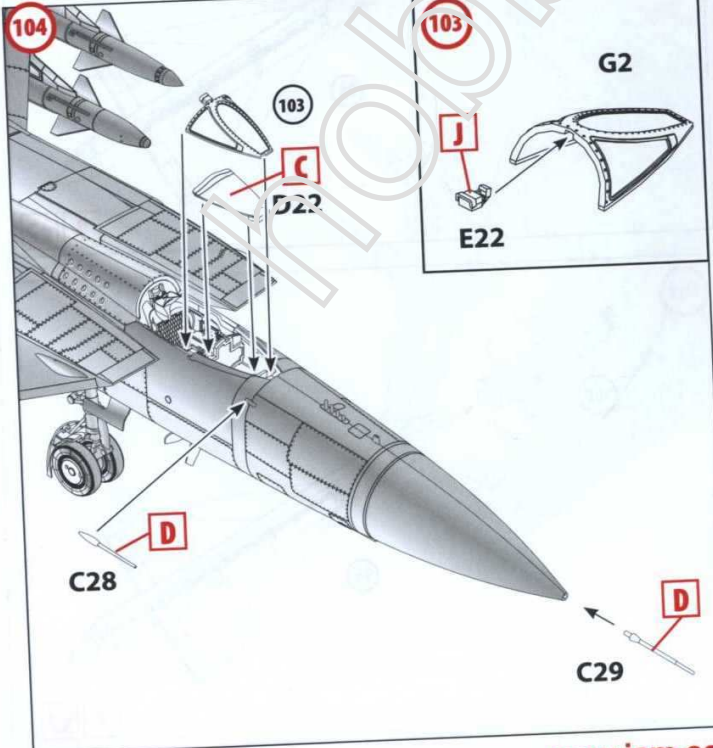

103

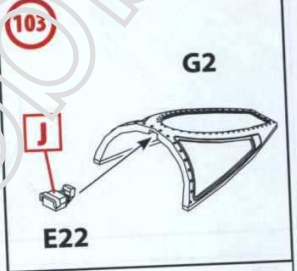

105

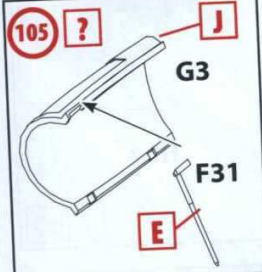

106

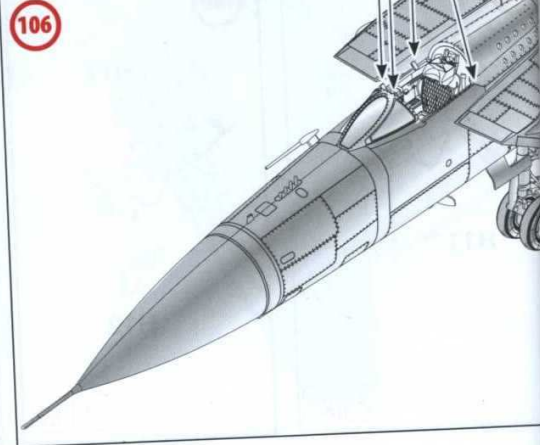



Model kit No48903

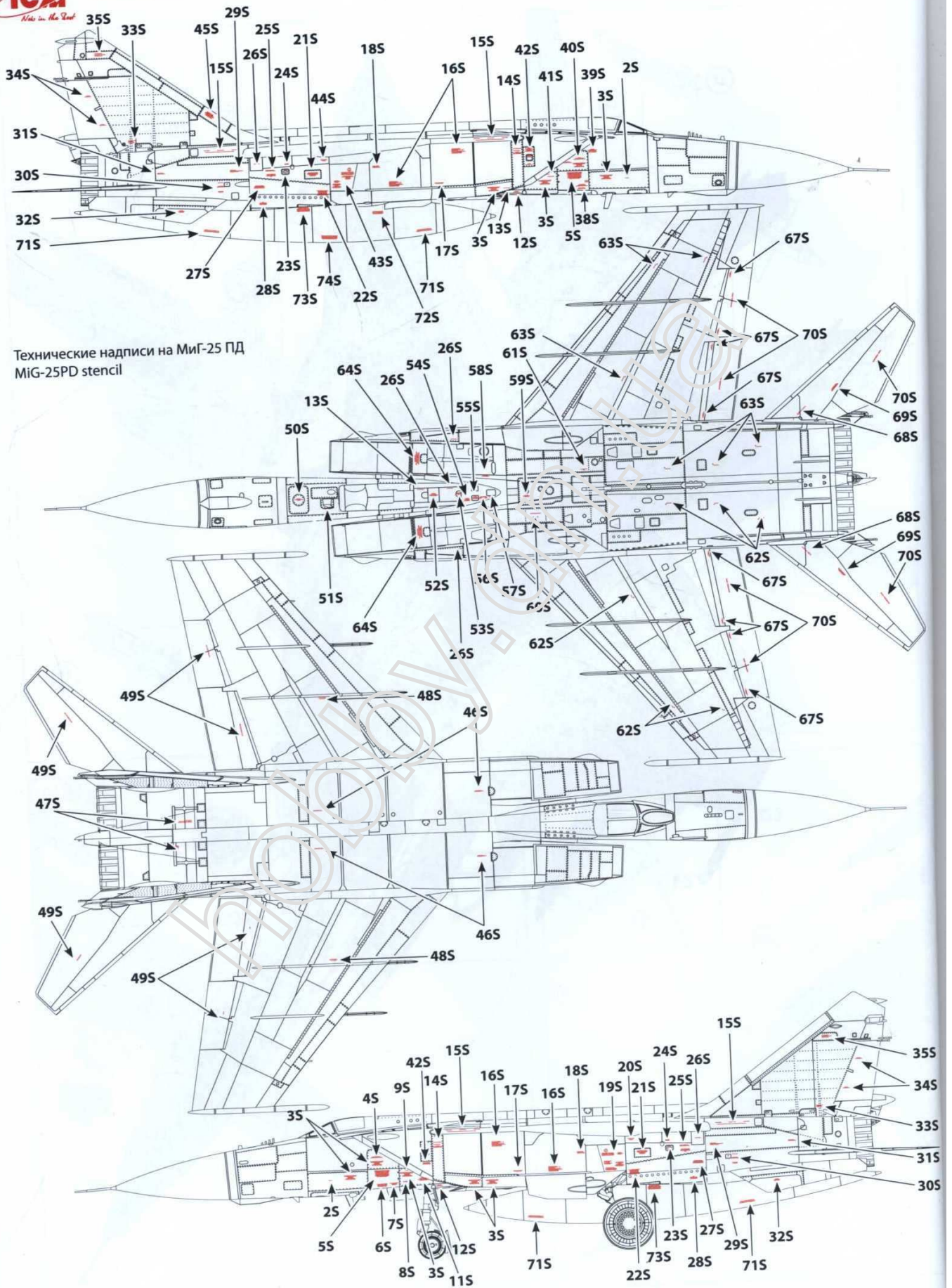

Технические надписи на МиГ-25 ПД
MiG-25PD stencil

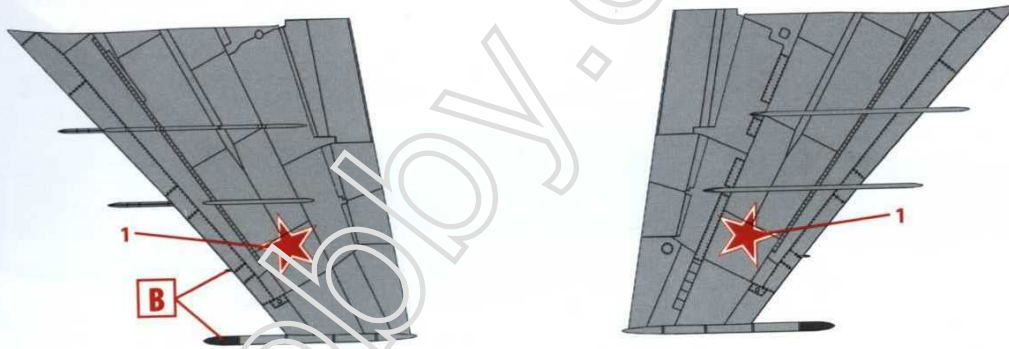
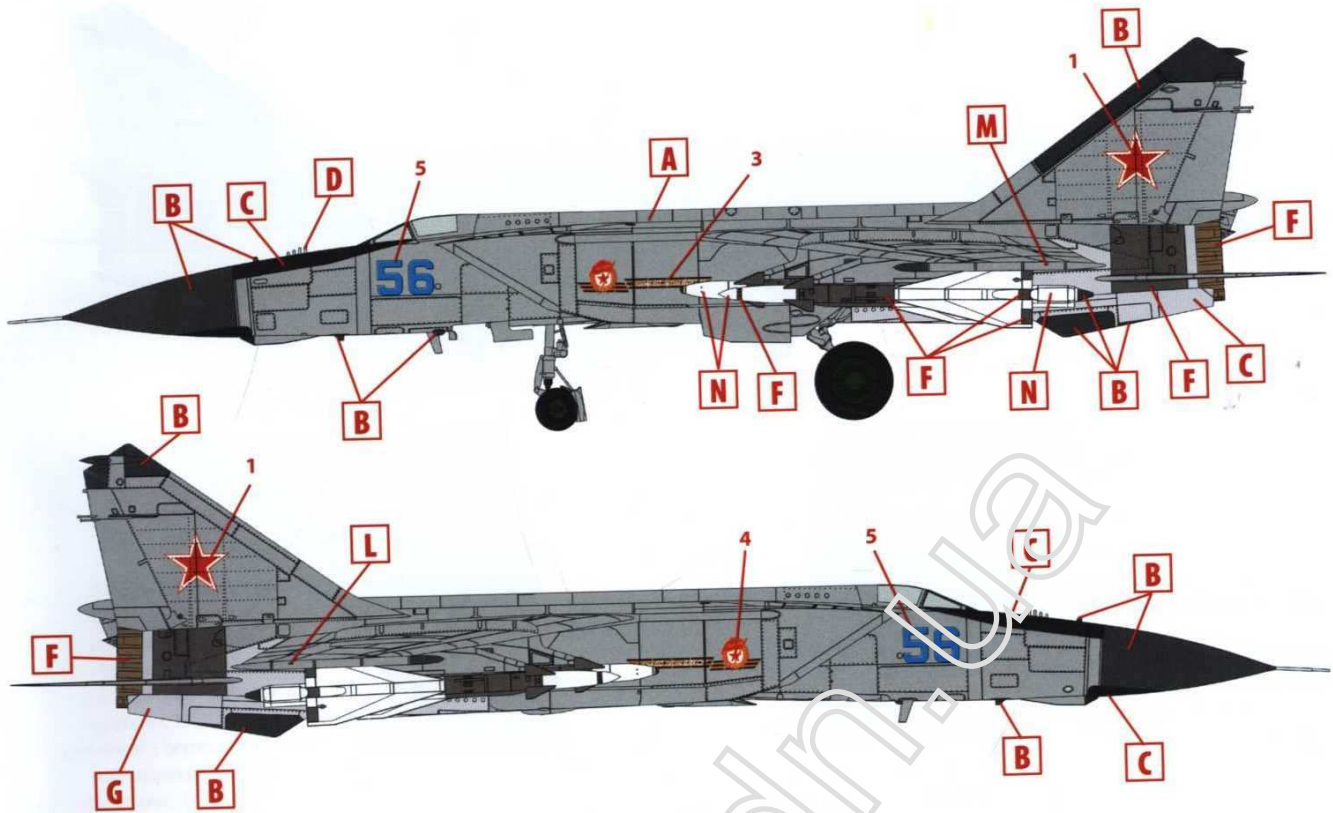

1 МиГ-25ПДС, 146-й ГвИАП, Васильков, 1989 г.
 MiG-25PDS, 146th Guard Fighter Regiment, Vasilkov, 1989

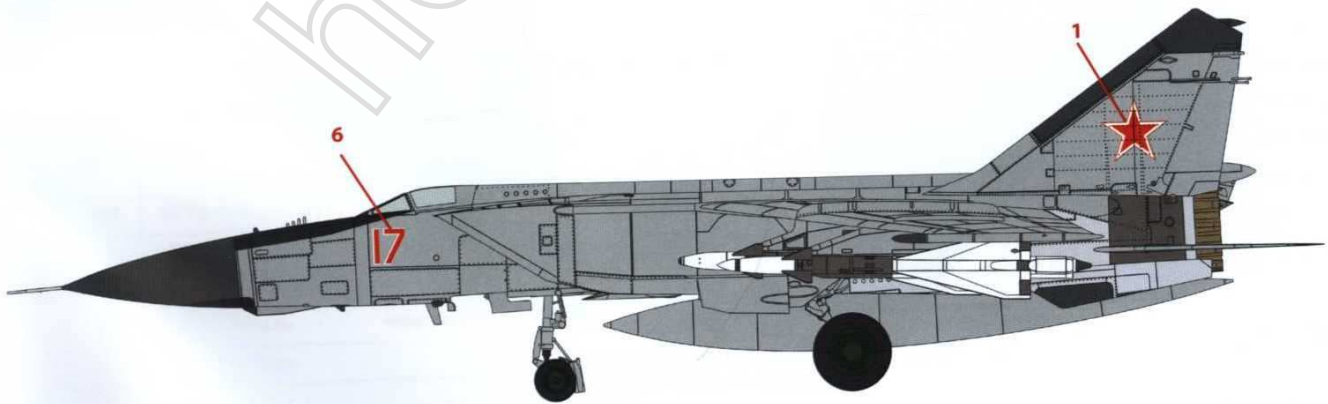

2. МиГ-25ПД, ВВС СССР, 1986 г.
 MiG-25PD, Soviet Air Force, 1986