

# KPM0148

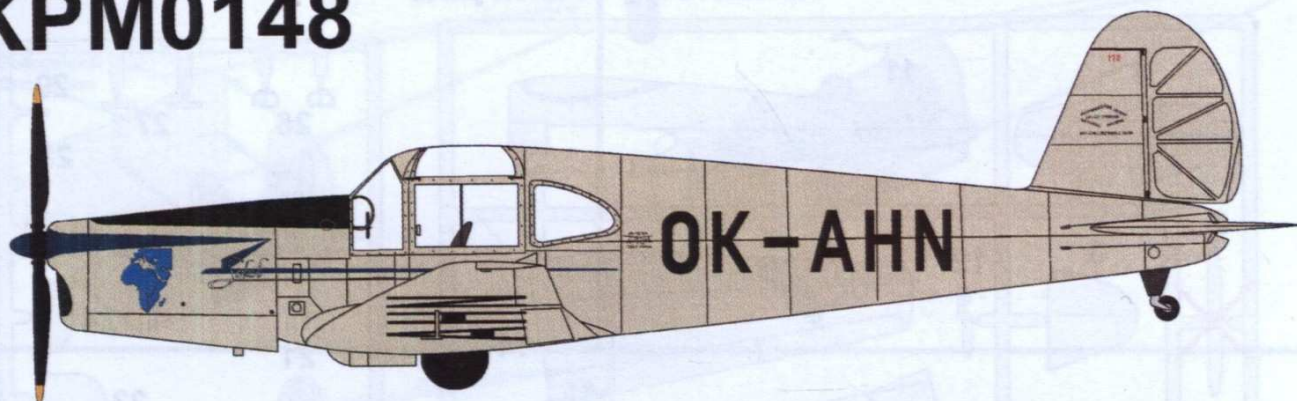

## Mráz M-1C SOKOL

### Mráz M-1C SOKOL

Konstruktérem prvního poválečného československého letounu M-1 Sokol byl spolupracovník Pavla Beneše, ing. Zdeněk Rublič. V Továrně letadel ing. J. Mráz v Chocni, kde se stal hlavním konstruktérem a národním správcem závodu, novým typem navázal na tradici ing. Beneše. Konstrukci M-1 Rublič promýšlel již před koncem války, kterou pojal jako technologicky velmi odlehčenou a zjednodušenou pro snadnou sériovou výrobu. Za pohon stroje vybral nový československý invertní vzduchem chlazený čtyřválec Walter Minor 4-III o výkonu 77 kW s dvoulistou dřevěnou vrtulí. Podvozek koncipoval jako ručně zatahovací směrem vzad pod okraj centroplánu, jehož část kol za letu vyčnívá mimo obrys profilu křídla. Jednalo se o ochranu letounu v případě nouzového přistání. Prototyp označený M-1A (OK-ZHA) poprvé vzlétl 9. března 1946.

#### TECHNICKÁ DATA/TECHNICAL DATA:

Posádka/Crew:	2
Motor/Powerplant:	1x Walter Minor 4-III
Výkon/Power:	77 kW
Rozpětí/Wingspan:	10,00 m
Délka/Length:	7,17 m
Výška/Height:	2,20 m
Nosná plocha/Wing area:	12,00 m <sup>2</sup>
Hmotnost prázdná/Empty weight:	400 kg
Hmotnost vzletová/Takeoff weight:	700 kg
Dostup/Climb:	5000 m
Dolet/Radius:	1000 km
Max. rychlost/Max. speed:	240 km/h

#### POUŽITÉ PODKLADY / REFERENCES USED:

Letectví a kosmonautika  
Československá letadla 2, Václav Němeček  
osobní archiv/personal files

### Mráz M-1C SOKOL

The Sokol was a conventional, low-wing monoplane that took the pre-war Beneš-Mráz Bibi as its starting point. Two seats were provided side-by-side in an enclosed cabin, and the main units of the tailwheel undercarriage were retractable. Construction throughout was of wood.

The prototype, then designated the M.1/1 and registered as OK-ZHA, first flew on 9 March 1946, following test flights the prototype was designated the M.1A as the two-seat-version. A re-engined two-seater was built designated the M.1B with a ZLAS Toma 4 engine, it first flew on 19 May 1946 but only one was built. Airframes were condemned in the early 1960s and withdrawn from use, under 20 were still in existence in the 2010s but only a few are flyable.

#### REALIZAČNÍ TÝM / REALISATION TEAM:

Předlohový model:	Petr Muzikant
Master model:	
Formy a výroba:	Jiří Válek
Moulds and production:	
Titulní kresba:	Gustav Hybner
Boxart:	
Návod:	Jarda Š
Instructions:	
Grafika a návrh obtisků:	Jan Polc
Graphic design, decals:	
Tisk obtisků:	KP
Decal printer:	
Konzultanti:	Slavomír Goldemund Miroslav Balous Václav Šorel Jaroslav Velc Michal Ovčáčik Petr Šafra Pavel Šipka



**VOLITELNÉ  
OPTIONAL**



**VYVRTAT  
DRILL HOLE**



**TMEL  
PUTTY**



**ODSTRANIT  
REMOVE**

Používejte pouze vhodné nářadí, lepidlo a barvy. Během práce nejezte a nepijte.  
POZOR - obsahuje malé součásti, které mohou mít ostré hrany. Není vhodné pro děti.

Use proper tools, glue and paints. Do not eat and drink during the work.  
WARNING - contains small parts with possible sharp edges. Not suitable for children.



Plastikové díly - Plastic parts

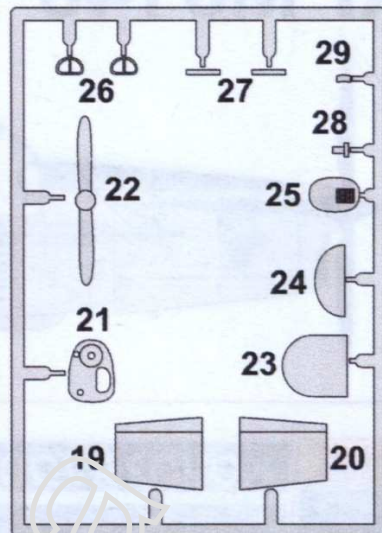
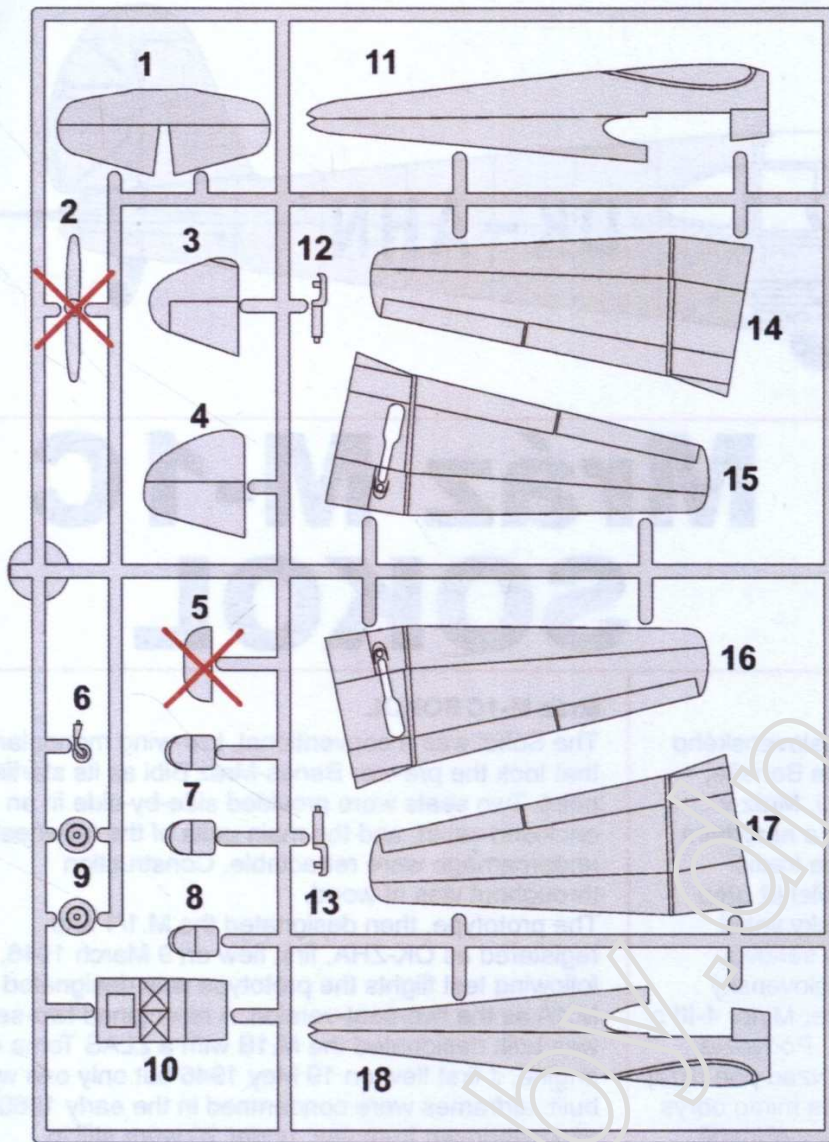

Průhledné díly/  
Clear parts

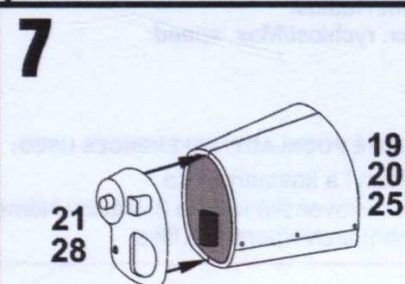
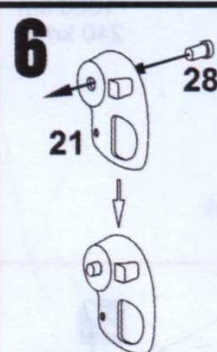
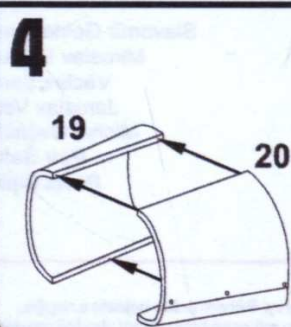
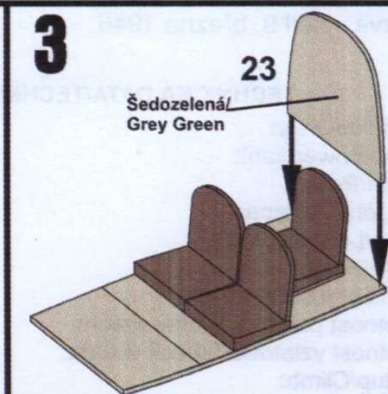
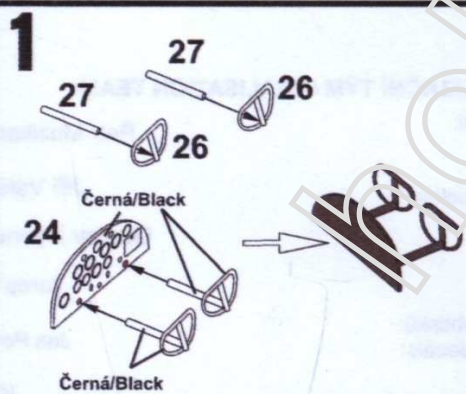
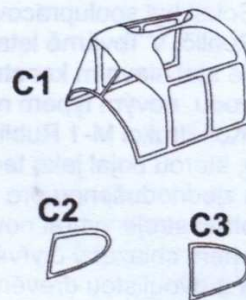

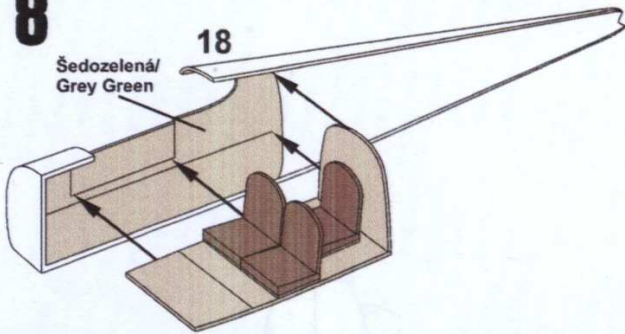
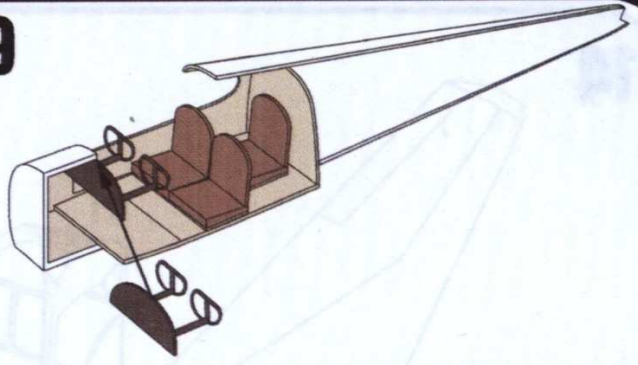
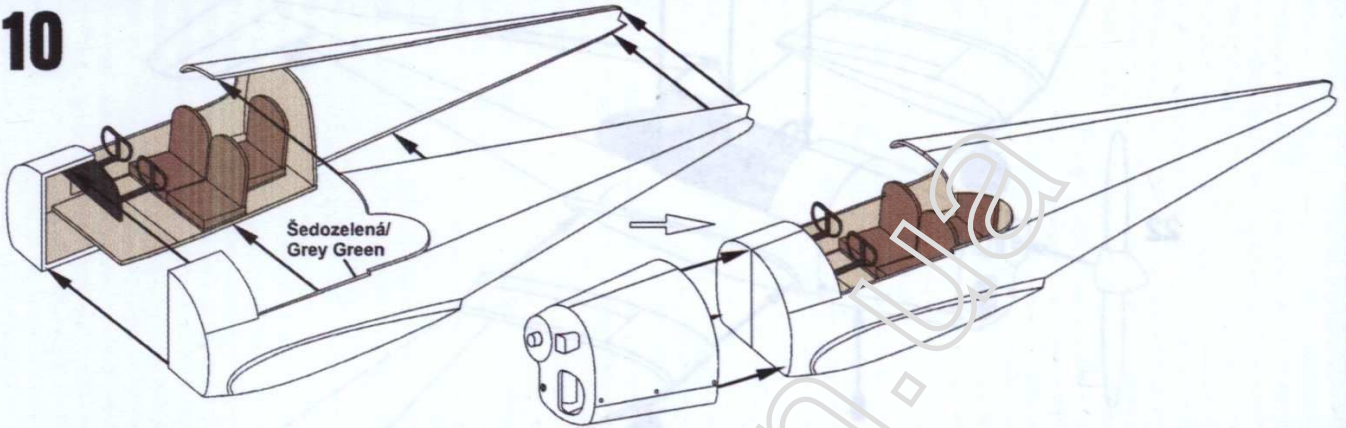
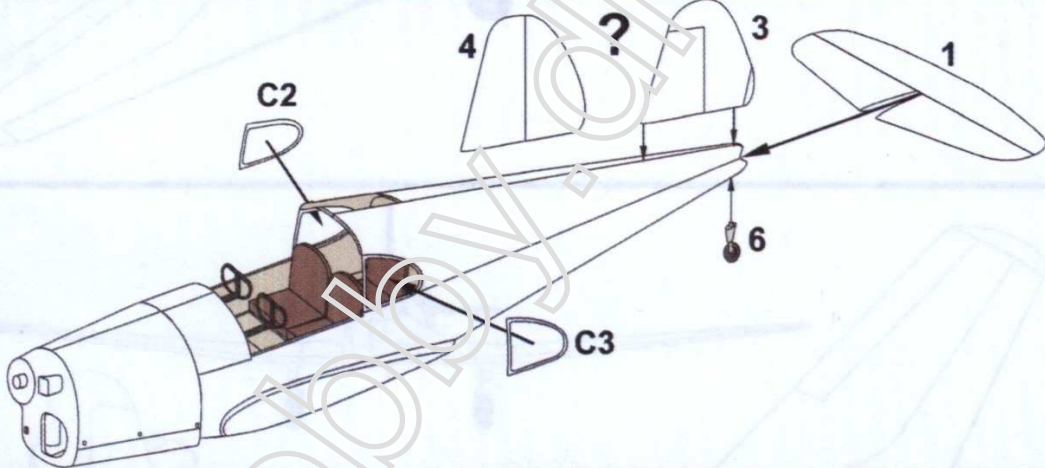
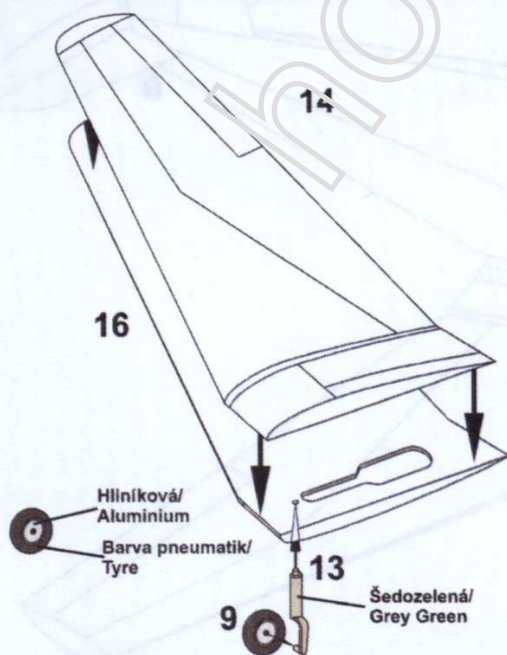
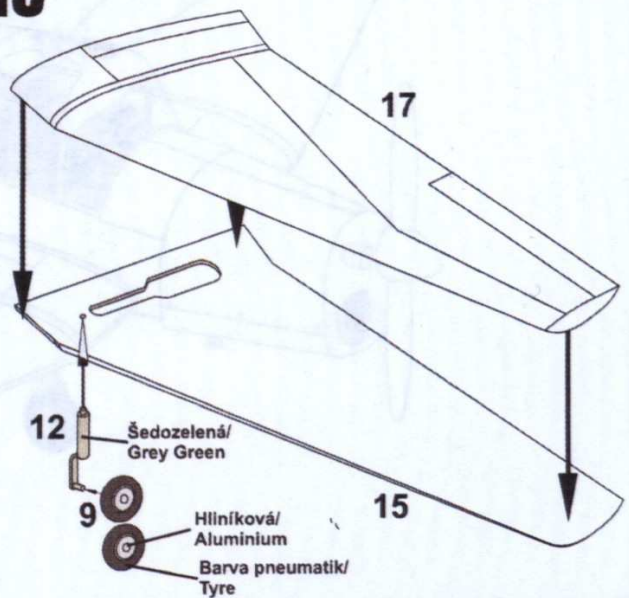

**8****9****10****11****12****13**



14

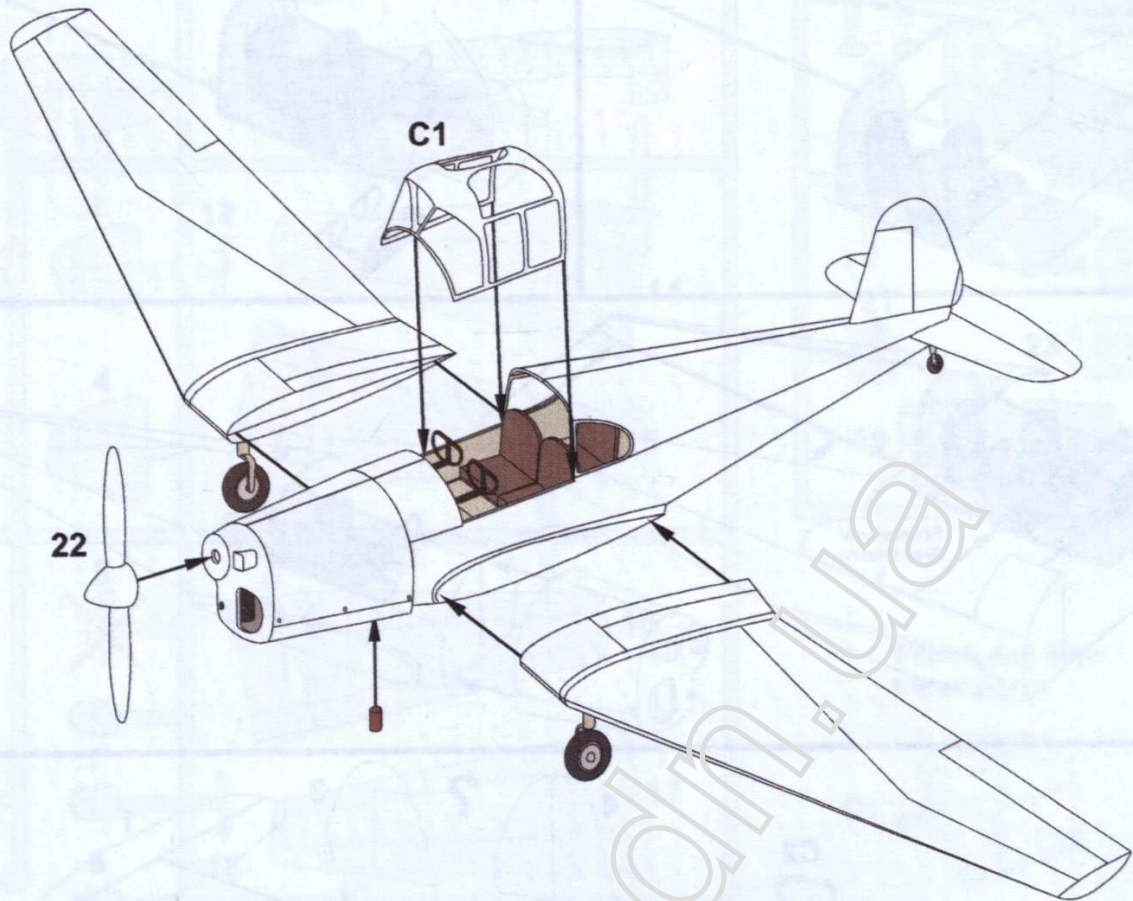

15

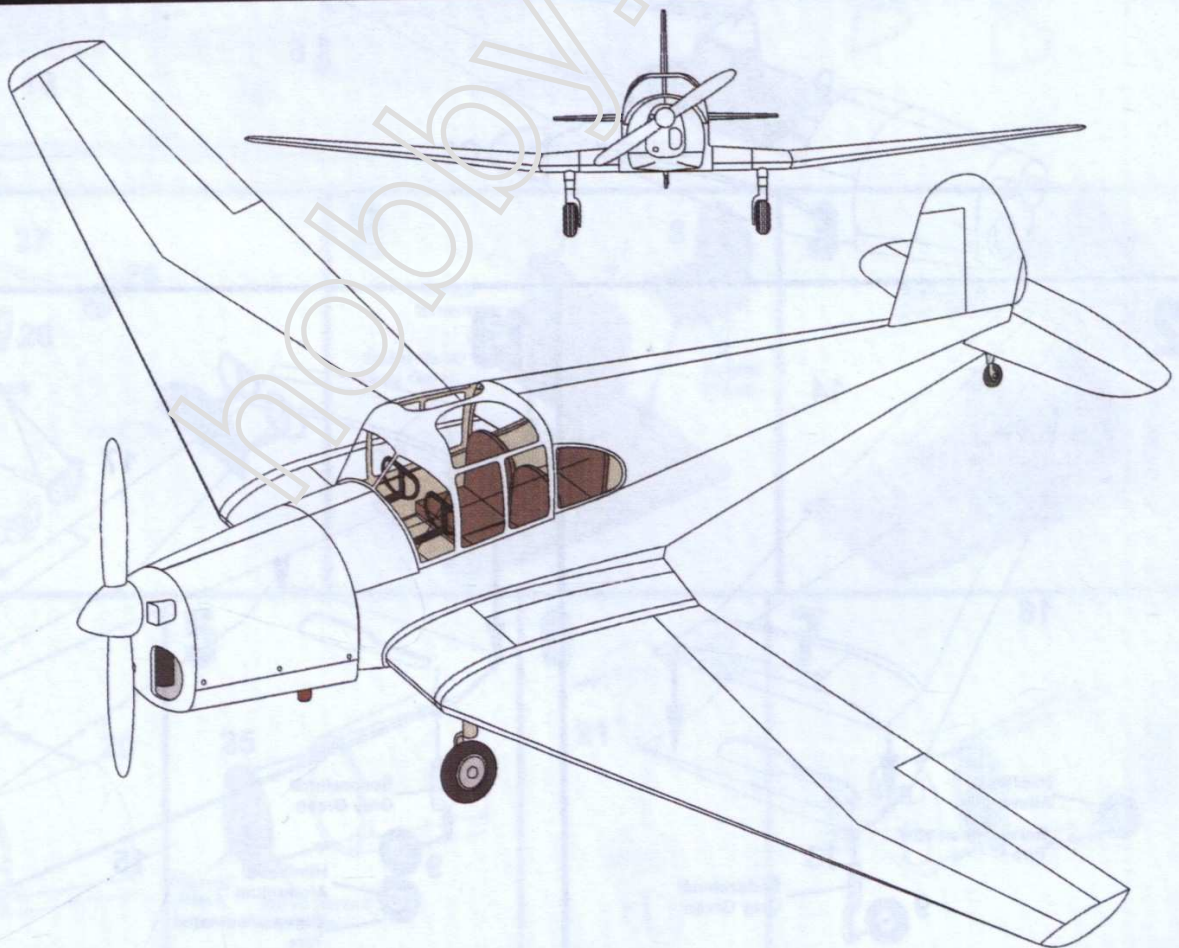

**1**

M-1C, OK-AHN, Choceň, etapový let Afrikou 1947.  
Stav exponátu v NTM Praha.

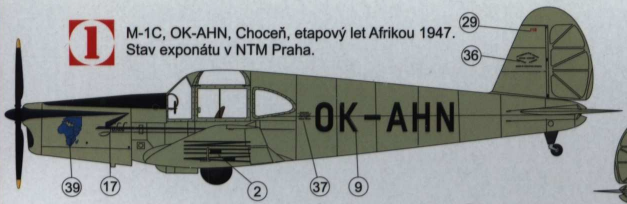

### Zbarvení & Označení Colours & Marking

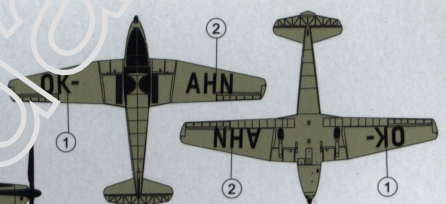

**2**

M-1C, OK-CSR, letiště Točná, 2017.

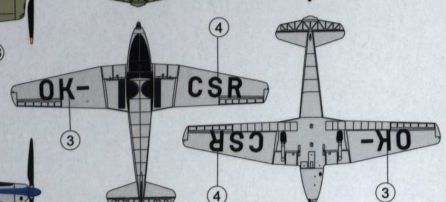
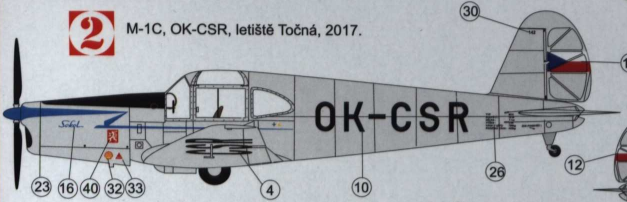

**3**

M-1C, OK-BHM, N.P. Odeva Trenčín,  
exponát LTM Praha-Kbely.

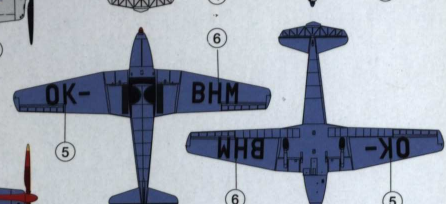
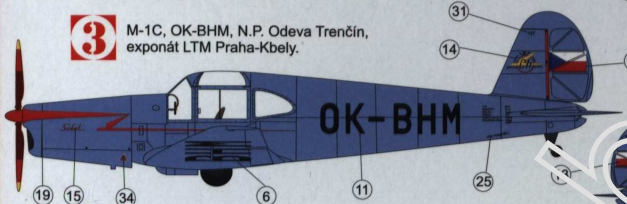

**4**

M-1C, OK-DHI, aeroklub Brno-Medlánky 1954.

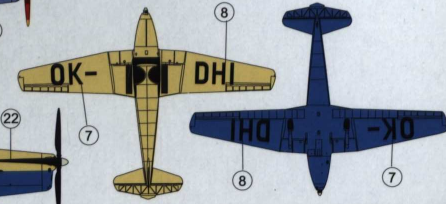

MIX  
Světlá šedozelená metaliza  
Light Grey Metallic Green

33 07  
Černá  
Black

11 08M  
Alumínová  
Hlízná

69 15  
Tmavě modrá  
Dark Blue

Zlutá  
Yellow

Světlá modrá  
Light Blue metallic

20 42M  
Tmavě červená  
Dark Red

19 17  
Červená  
Red

Paint Numbers: Číslo barev:  
HUMBROL AGAMA  
KOVŮZÁVODY  
PROSTĚJOV

41 39  
Křémová  
Creme