

GERMANY WWII JAGDPANZER E-100 TANK DESTROYER WITH 170MM GUN



ITEM NO: UA72116

The Panzerkampfwagen E-100 (Gerät 383) (TG-01) was a German super-heavy tank design developed near the end of World War II. It was to also be the basis for a heavy artillery system, an anti-aircraft vehicle, and a heavy tank destroyer. However, the development of these last was never started due to the end of World War II, by which time only the E-100's chassis was partially completed. It was shipped to the United Kingdom for testing, and was later scrapped.

The basic design was ordered by the Waffenamts as a parallel development to the Porsche Maus in June 1943. It was the heaviest of the Entwicklung (E) series of vehicles, meant to standardize as many components as possible. There was going to be an E-5, E-10, E-25, E-50, E-75 and finally the E-100. In November 1942, Krupp suggested a design weighing 155 tons, compared to the 188 tons of the Maus - but still using the Maus turret. In December 1942, Krupp suggested a design weighing 130 tons which used many of the same components as the Tiger tank with Maus turret - referred to as the "Tiger-Maus". Weight savings were to be from thinner armor, and narrowing and shortening the vehicle.

In 1944 Hitler ordered the development of super heavy tanks to stop, work on the E-100 however continued at a very low priority, with only three Adler employees available to assemble the prototype.

The prototype had a HL 230P30 engine and Olvar transmission fitted. The HL 230 was the same V-12 engine and that was used on the Tiger II and Panther tanks. It was suitable for the 45-tonne Panther, underpowered for the 70-tonne Tiger II, and grossly under-powered for a 140-tonne design. The chassis of the prototype was virtually completed however it lacked a turret that would have been fitted with the 15 cm KwK 44 gun. The final version was to be powered by an HL234 producing 850 hp mated to a Mekydro transmission. A 17 cm KwK 44 was proposed as the final armament. Suspension was to be the externally mounted Belleville Washer type. The hull had sloped armor, typical of post-1943 design. Wheels were overlapped, similar to the Tiger II and Panther tank, and no longer interleaved as with the Schachtellaufwerk suspension of the original Tiger I.

Specifications

Weight	140 tonnes (154 short tons; 138 long tons)
Crew	6
Armor	150–200 millimetres (5.9–7.9 in) (hull front) 120–150 millimetres (4.7–5.9 in) (hull sides and rear) 40 millimetres (1.6 in) (hull top) 40–80 millimetres (1.6–3.1 in) (hull bottom) 200 millimetres (7.9 in) (turret front) 80–150 millimetres (3.1–5.9 in) (turret sides and rear) 40 millimetres (1.6 in) (turret top)
Main armament	12.8 cm KwK 44 L/55 15 cm KwK 44 L/38, or 17.3 cm KwK 44 (Note: the 17.3 cm KwK 44 was only going to be mounted on the non-turreted tank destroyer like variant of the E-100)
Power/weight	4.52 hp/ton (prototype)5.48 hp/ton (proposed)
Suspension	Belleville washer coil spring
Operational range	190 km (120 mi) (road)
Speed	40 km/h (25 mph)

●READ BEFORE ASSEMBLY

1. When you use glue or paint, do not near flame, and use in a well-ventiated room.
2. Take extra care in handling photo etch parts in order to avoid injury
3. When you take parts off the runner frame, use modeling scissors and trim excess plastic with a cutter or a file.
4. Glue and paint are not included.
5. This product is only suitable for experienced more than 14 years old.

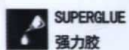

强力胶

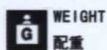

配重

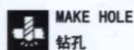

钻孔

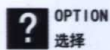

选择

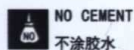

不涂胶水

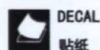

贴纸

DECAL APPLICATION

1. Cut off decal from sheet.
2. Dip the decal in tepid water 40° C for about 10 sec. and place on a clean cloth.
3. Hold the backing sheet edge and slide decal onto the model.
4. Move decal into position by wetting decal with finger.
5. Press decal gently down with a soft cloth until excess water and air bubbles are gone.

●装配之前仔细阅读:

1. 勿於近火处使用胶水或油漆, 并打开窗户保持空气流通。
2. 取蚀刻片时应特别注意安全, 防止利边划伤手指。
3. 从胶架中取出部件时, 应用模型专用剪, 并用界刀或小锉除去多余的胶料。
4. 请使用塑料胶水和油漆, 模型内不含。
5. 本产品不适合14岁以下没有经验的模型爱好者。

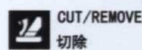

切除



弯曲



锉平

水贴纸的使用:

1. 从水贴纸上剪下印花。
2. 将印花放入温水中浸10秒, 然后放在干净布上。
3. 拿着印花纸板将印花移到模型上。
4. 手指蘸水将印花移到适当的位置。
5. 用软布轻压印花直至不干, 气泡消失。

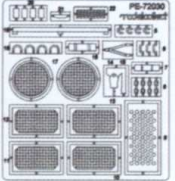
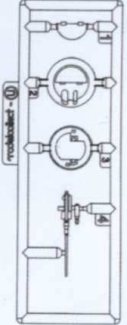
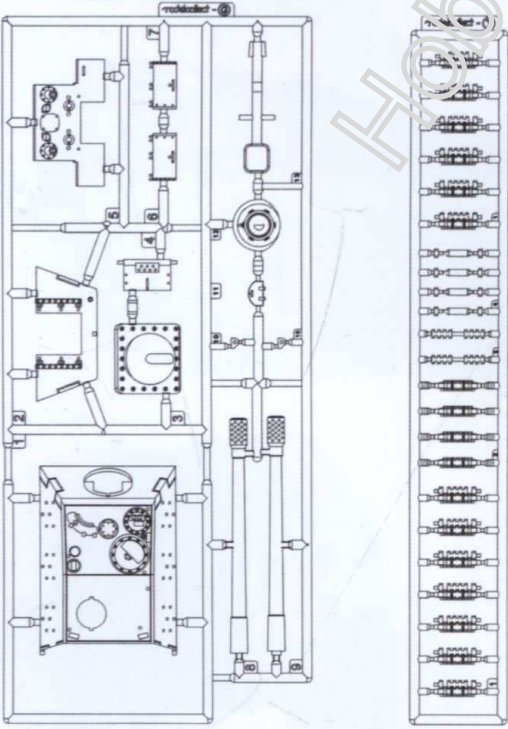
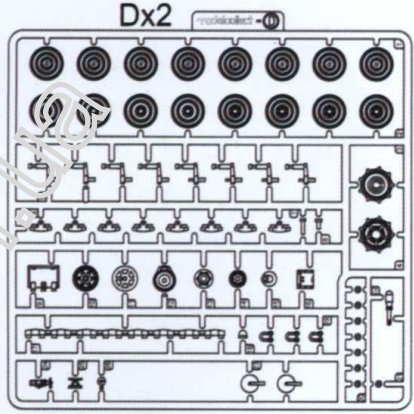
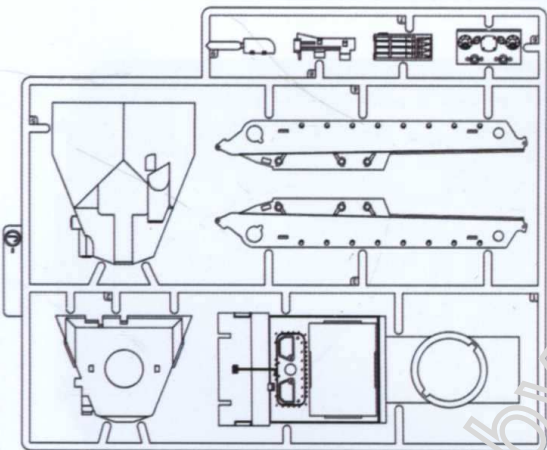
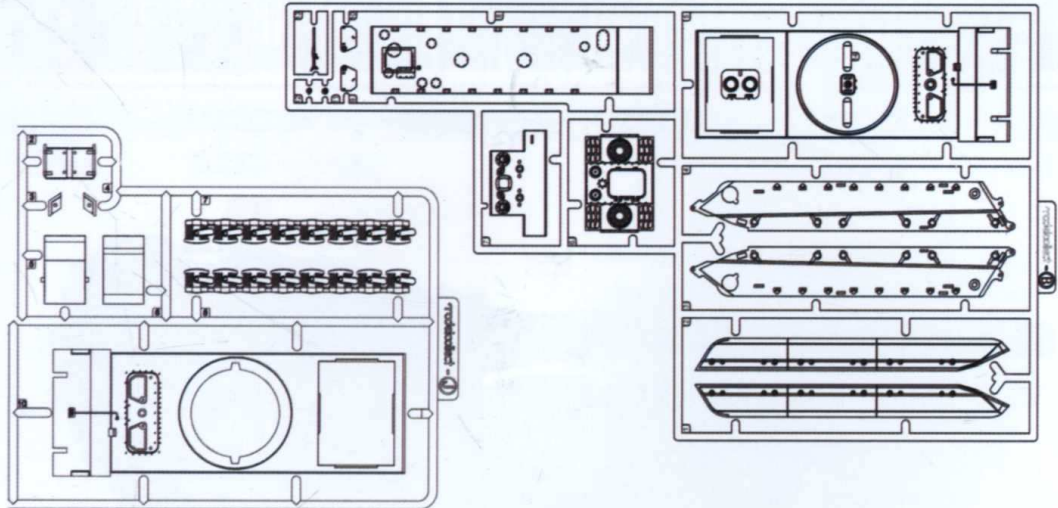

PE-72030

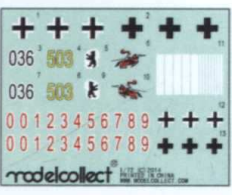

Decal



Track X 2

1 attaching turret parts 1

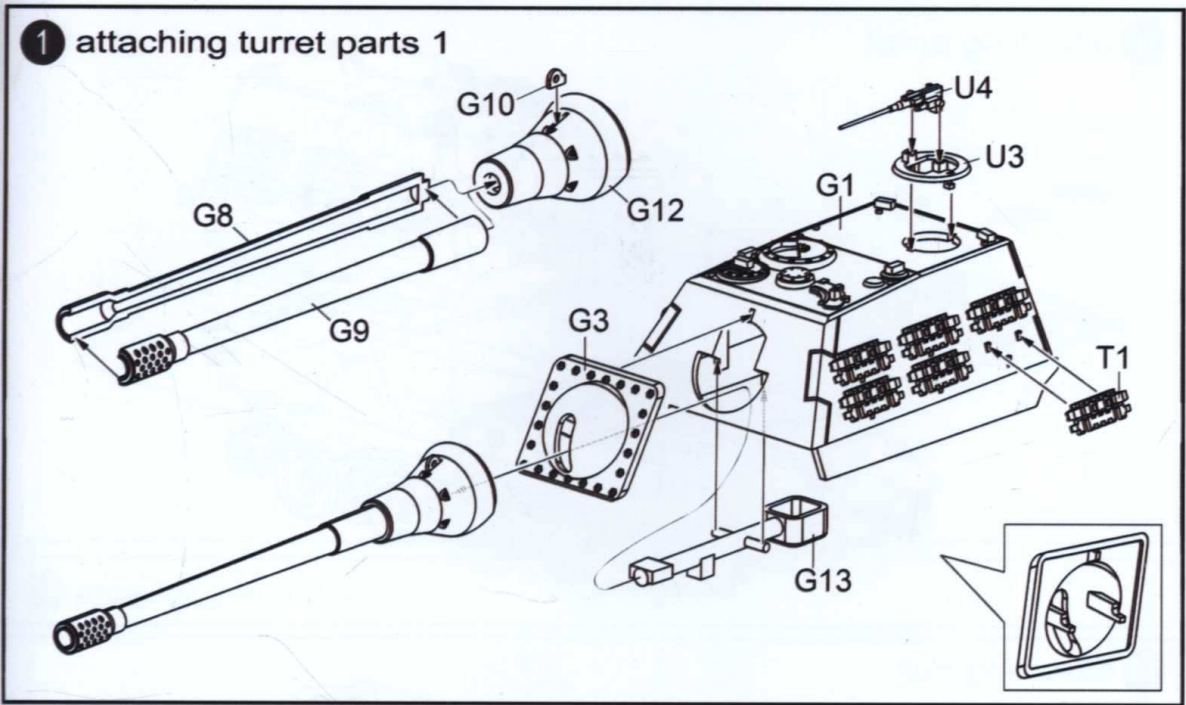

2 attaching turret parts 2

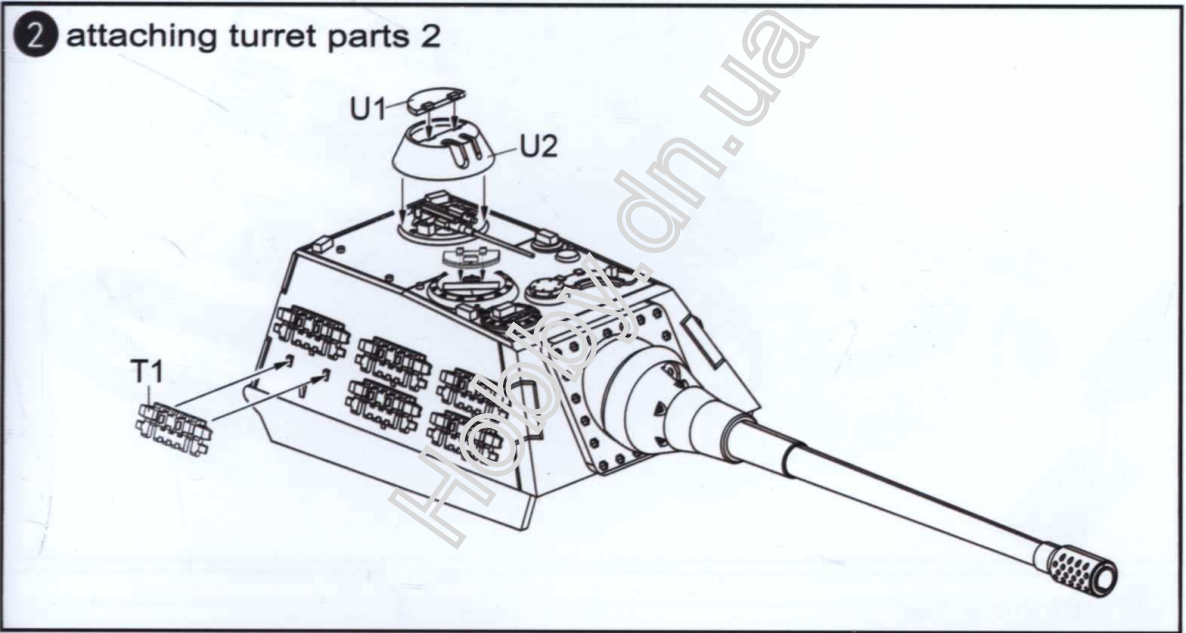

3 attaching turret parts 3

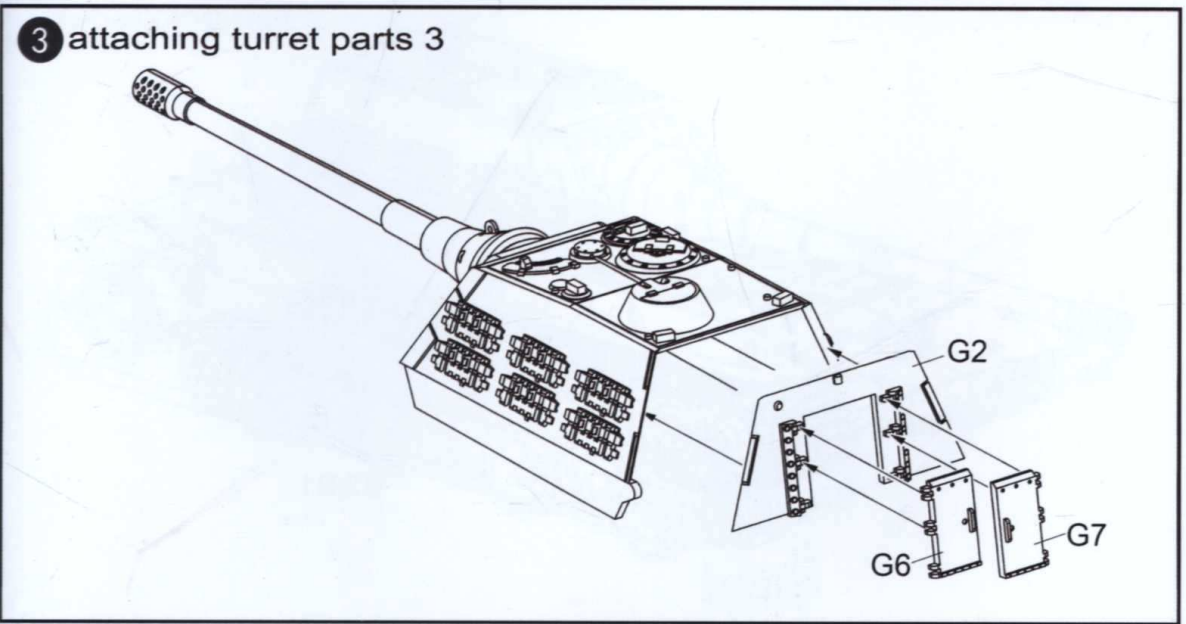

4 attaching wheels

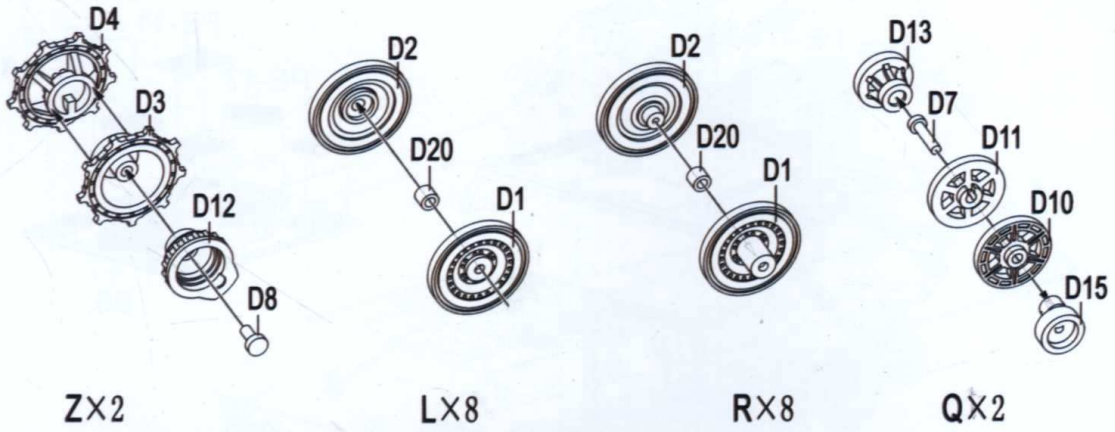

5 attaching suspension 1

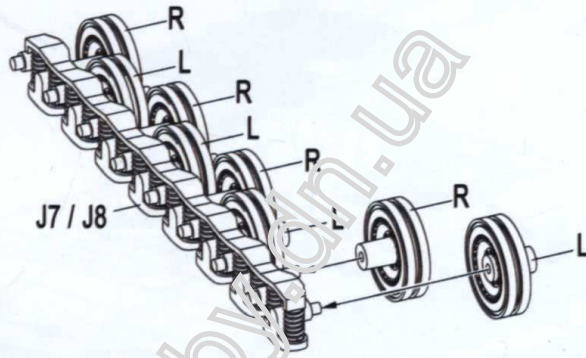

6 attaching suspension 2

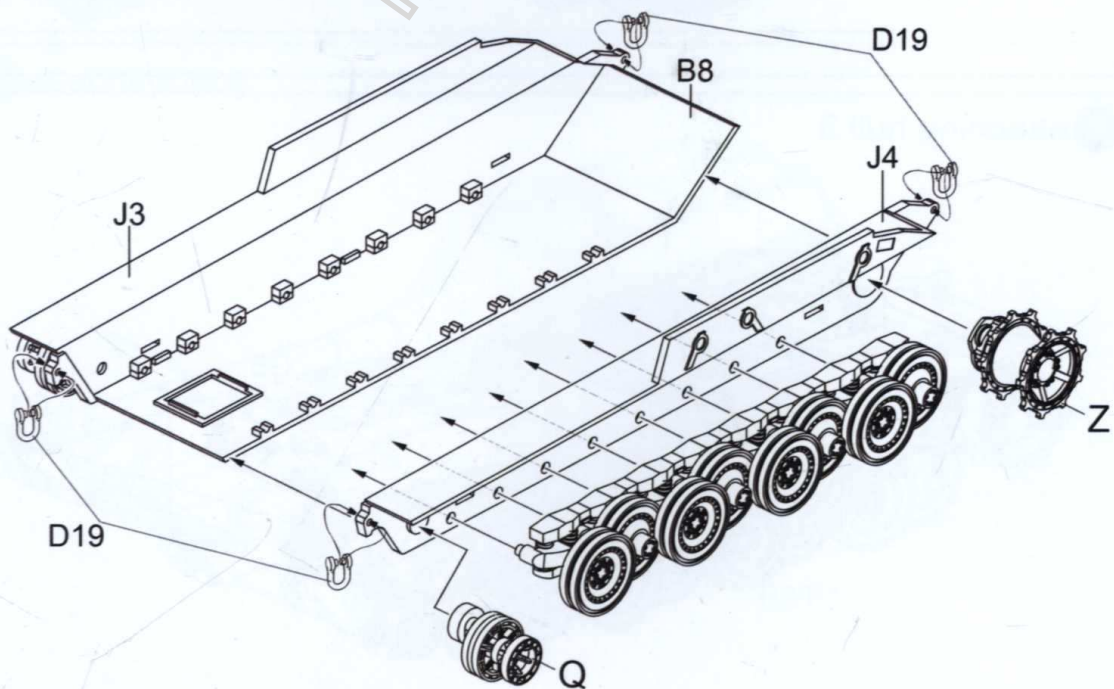

7 attaching hull 1

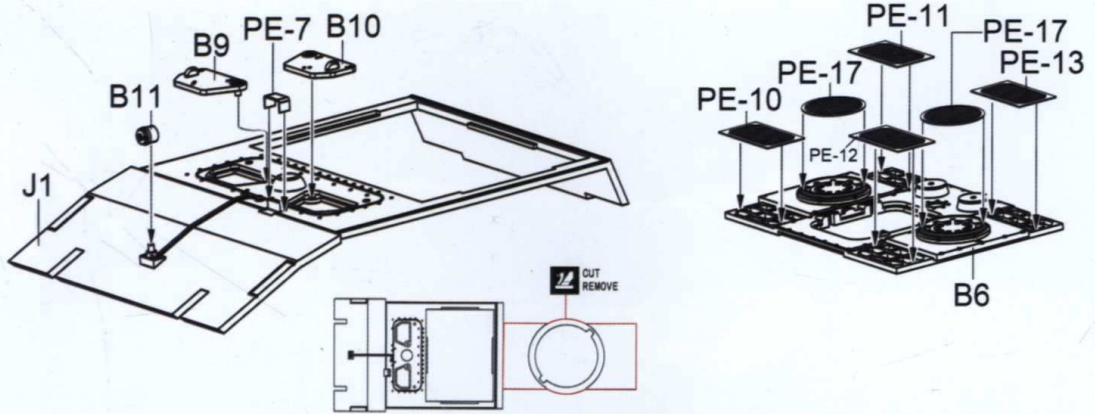

8 attaching hull 2

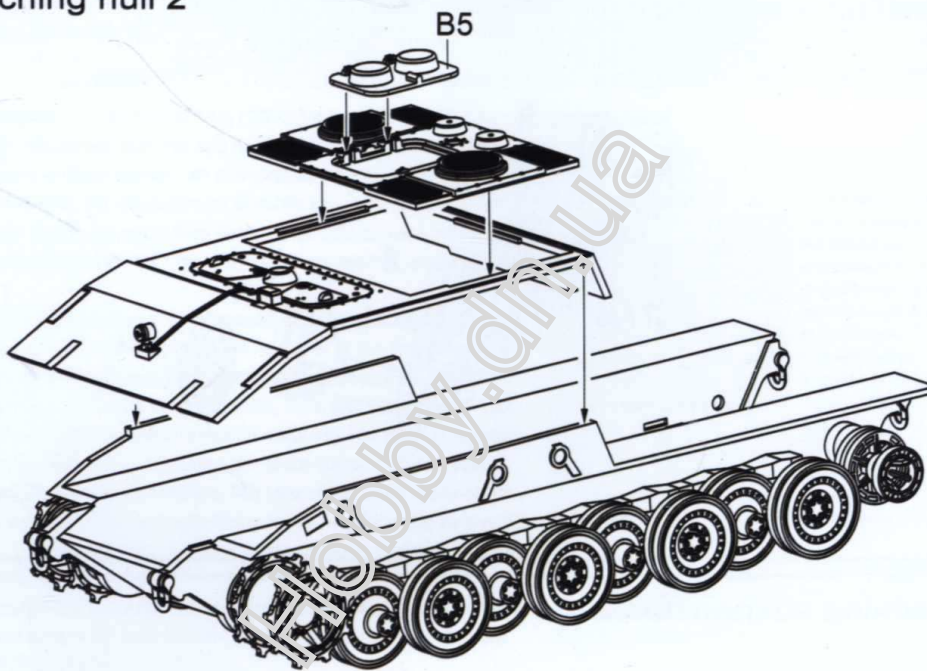

9 attaching hull 3

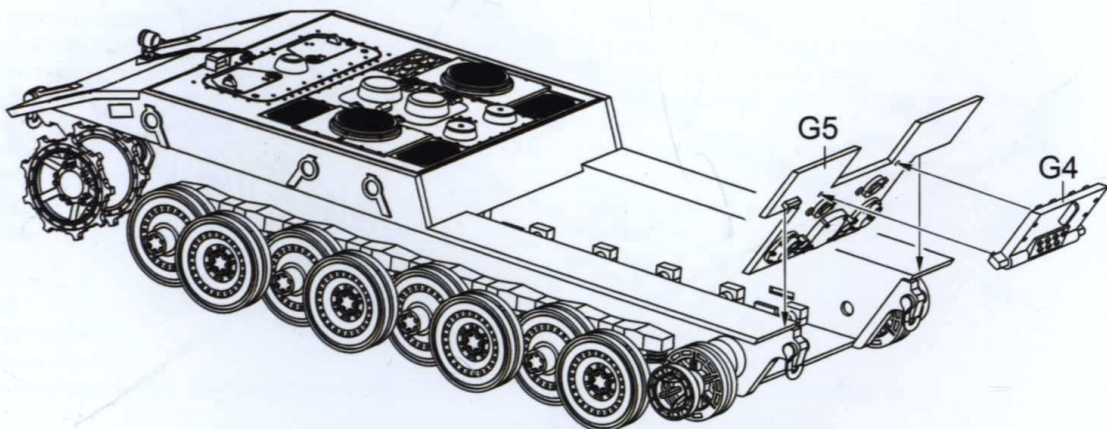

10 attaching turret

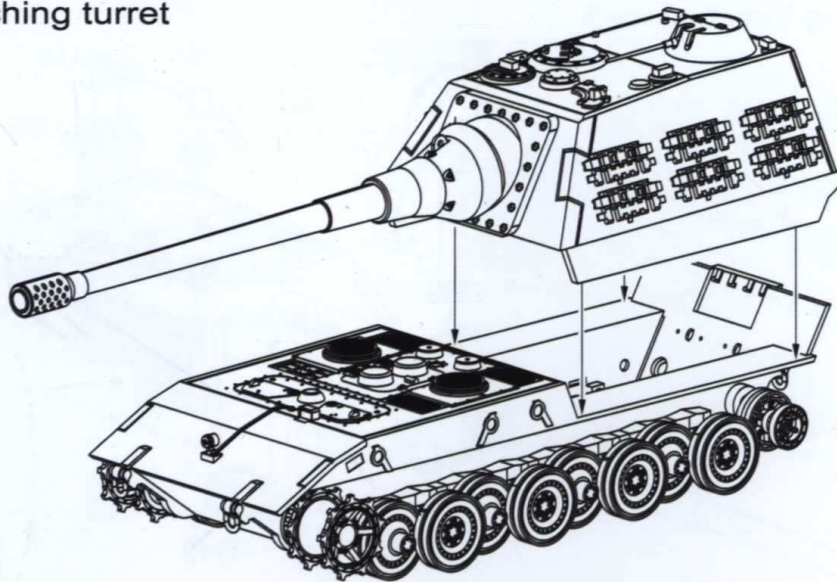

11 attaching hull

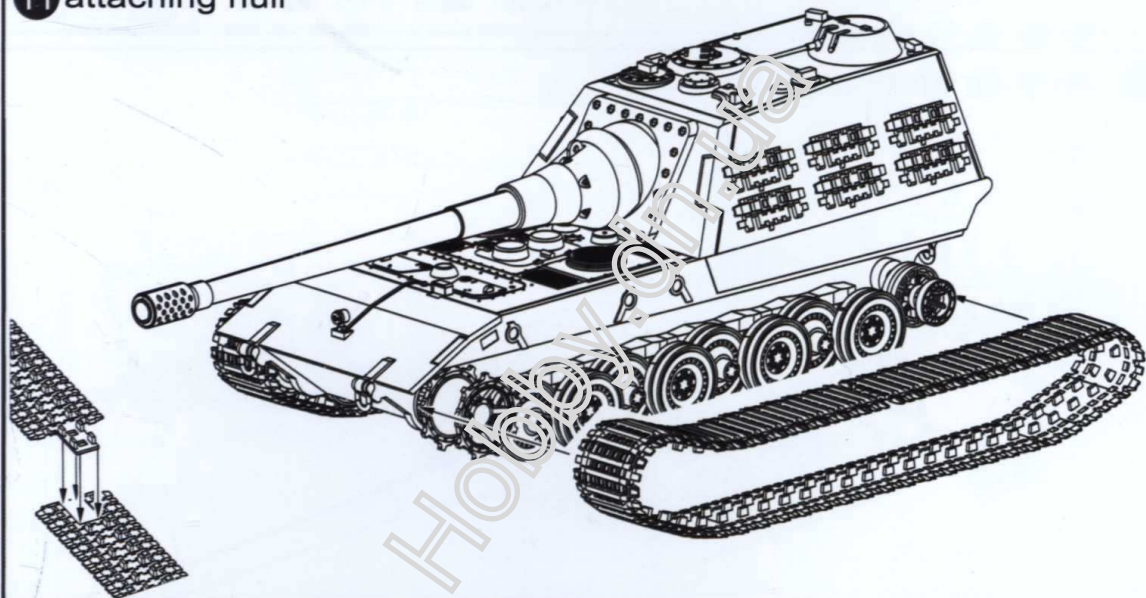

12 attaching hull

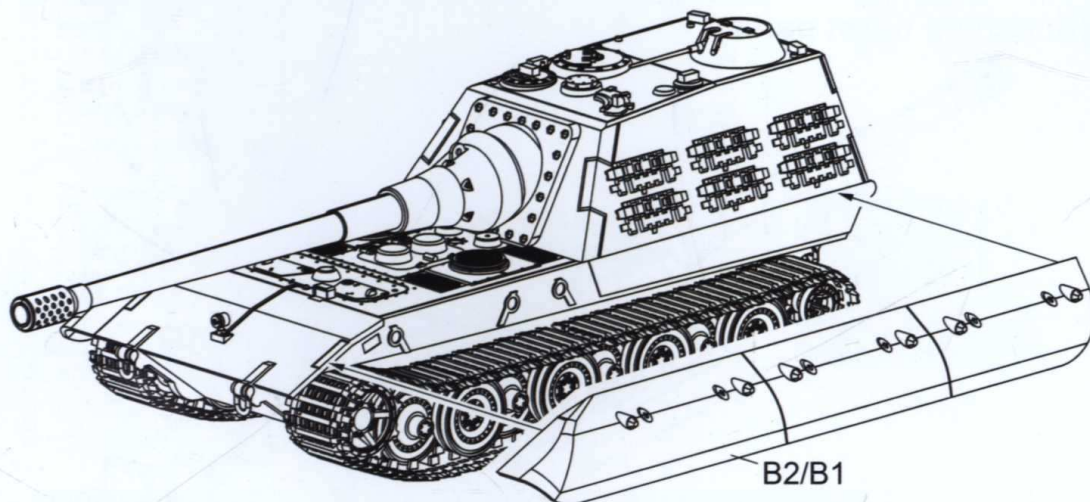

GERMANY WWII JAGDPANZER E-100 TANK DESTROYER WITH 170MM GUN

modelcollect

A.MIG 011 RAL 7028 DUNKELGELB AUS '44 DG I

A.MIG 014 RAL 8012 ROTBRAUN

A.MIG 003 RAL 6011 RESEDAGRÜN

A.MIG 033 Rubber & Tires

A.MIG 045 GUN METAL

A.MIG 095 CRYSTAL SMOKE

A.MIG 037 NEW WOOD

A.MIG 192 POLISHED METAL

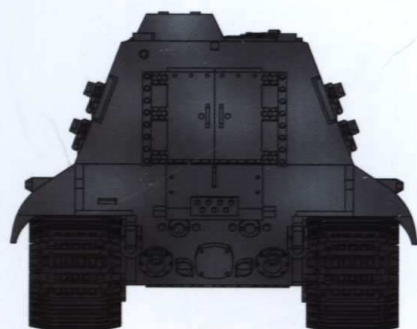
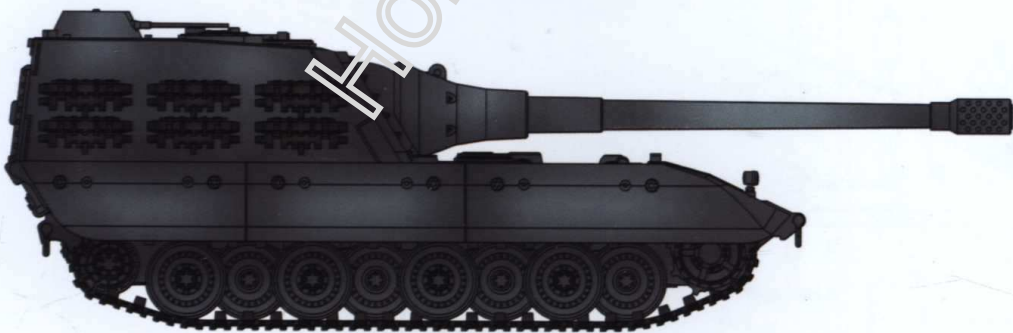
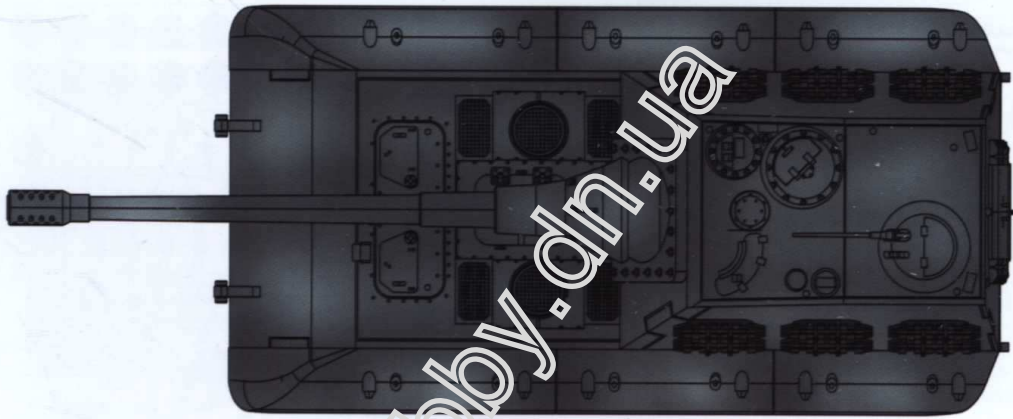
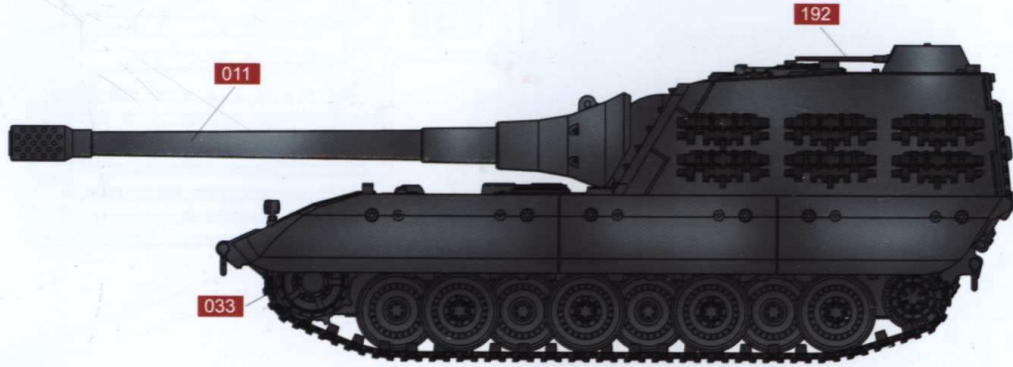

MODELCOLLECT

Color info and profiles by



GERMANY WWII JAGDPANZER E 100 TANK DESTROYER WITH 170MM GUN



- A.MIG 011 RAL 7025 DUNKELGELB AUS '44 DG 1
- A.MIG 014 RAL 8012 ROTBRAUN
- A.MIG 003 RAL 8011 RESEDAGRÜN
- A.MIG 033 Rubber & Tires
- A.MIG 045 GUN METAL
- A.MIG 095 CRYSTAL SMOKE
- A.MIG 037 NEW WOOD
- A.MIG 192 POLISHED METAL

