

modelcollect

WITH M870A1 SEMI-TRAILER
GERMAN MAN KAT1 M1014 8x8 HIGH-MOBILITY OFF-ROAD TRUCK

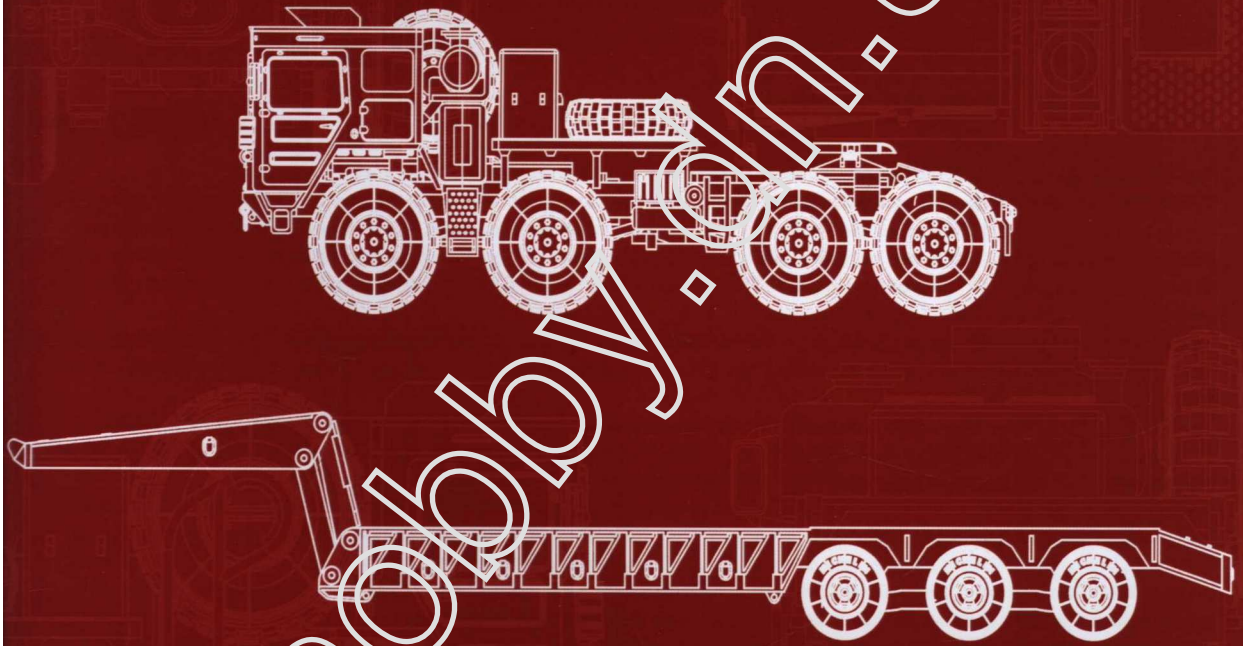

搜模閣

UA72125
1:72
SCALE

GERMAN MAN KAT1 M1014 8x8 HIGH-MOBILITY OFF-ROAD TRUCK WITH M870A1 SEMI-TRAILER

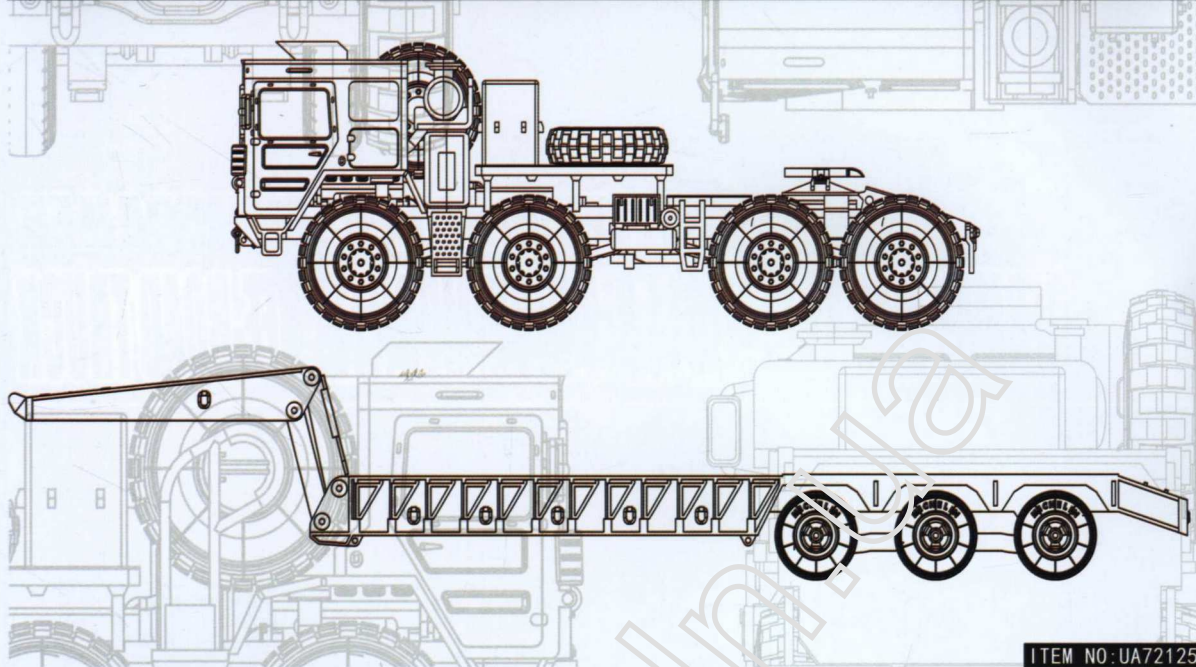

ITEM NO: UA72125

The MAN KAT1 was a family of high-mobility off-road trucks developed by MAN SE for the German army.

In 1962 the Bundeswehr planned to replace its fleet of vehicles, which still stemmed from the time the army had been founded. It wanted amphibious two-, three- and four-axle vehicles in the 4 to 10 ton payload range. Because a high degree of new development was necessary, the German federal agency for defence technology and procurement (Bundesamt für Wehrtechnik und Beschaffung, BWB) found itself unable to accept the responsibility for a decision but suggested the bidding companies form a common development bureau and agree on one unified project.

Two years later in 1964, the "Common Bureau of the German Utility Vehicle Industry" (Gemeinschaftsbüro der deutschen Nutzfahrzeugindustrie) was formed under the leadership of MAN. The manufacturers (Klockner-Humboldt-Deutz (KHD), Büssing, Krupp and Henschel) were also on board.

On 12 August 1964, BWB drafted the second generation requirements. Specification of the next generation called for mostly standard commercial vehicles with unlimited cross-country mobility, amphibious, with permanent all-wheel drive, low-pressure run flat tires, a steel cab, NBC protection, a multifuel engine and a minimum service life of ten years.

Because procurement costs would have been too high and NATO established a new standard, the amphibious, NBC and multifuel capabilities were subsequently cancelled and requirements redefined. Payload of the twin-axle version was increased to 5 t, fording depth specified to 1,200 mm, bed height raised to 1,650 mm, and air cooled Deutz V8 engines with and without turbocharger as well as 14.00 R 20 size tires were specified. However, even this "trimmed-down" version was too expensive for comprehensive procurement. After further deliberations it was decided to procure a smaller number of the specialized, newly developed high-mobility trucks and supplement them with a number of near-standard trucks. This meant the army procured altogether six different new truck models, initially three of them in the high-mobility off-road category.

On 4 December 1975, the Bundeswehr and MAN signed the procurement treaty about the delivery of the special military trucks, now split even further into two more categories. The first Kategorie I-MAN, the 10 t mil gl, was delivered on 29 November 1976.

The original intention was to build a family of logistics vehicles which could carry full loads across severe terrain whilst keeping up with modern main battle tanks.

The first model produced was 8x8; 6x6 and 4x4 variants followed.

The original KAT1 evolved into the MAN SX. A few ex-military MAN KAT1 vehicles are released onto the second-hand market in Germany.

The US Army and the US Air Force operated 4 variations of the 8x8 model under the designations M1001, M1002, M1013 and M1014.

●READ BEFORE ASSEMBLY

1. When you use glue or paint, do not near flame, and use in a well-ventilated room.
2. Take extra care in handling photo etch parts in order to avoid injury.
3. When you take parts off the runner frame, use modeling scissors and trim excess plastic with a cutter or a file.
4. Glue and paint are not included.
5. This product is only suitable for experienced more than 14 years old.

●装配之前仔细阅读:

1. 勿於近火处使用胶水或油漆, 并 打开窗户保持空气流通。
2. 取蚀刻片时应特别注意安全, 防止利边划伤手指。
3. 从胶架中取出部件时, 应用模型专用剪, 并用界刀或小锥除去多余的胶料。
4. 请使用塑料胶水和油漆, 模型内不含。
5. 本产品不适合14岁以下没有经验的模型爱好者。

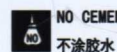
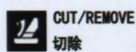
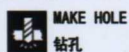
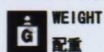
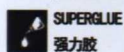

DECAL APPLICATION

1. Cut off decal from sheet.
2. Dip the decal in tepid water 40° C for about 10 sec. and place on a clean cloth.
3. Hold the backing sheet edge and slide decal onto the model.
4. Move decal into position by wetting decal with finger.
5. Press decal gently down with a soft cloth until excess water and air bubbles are gone.

水贴纸的使用:

1. 从水贴纸上剪下印花。
2. 将印花放入温水中浸10秒, 然后放在干净布上。
3. 拿着印花纸板将印花移到模型上。
4. 手指蘸水将印花移到适当的位置。
5. 用软布轻压印花直至不干, 气泡消失。

Parts

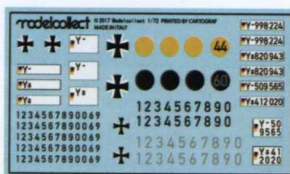
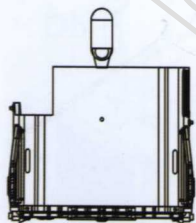
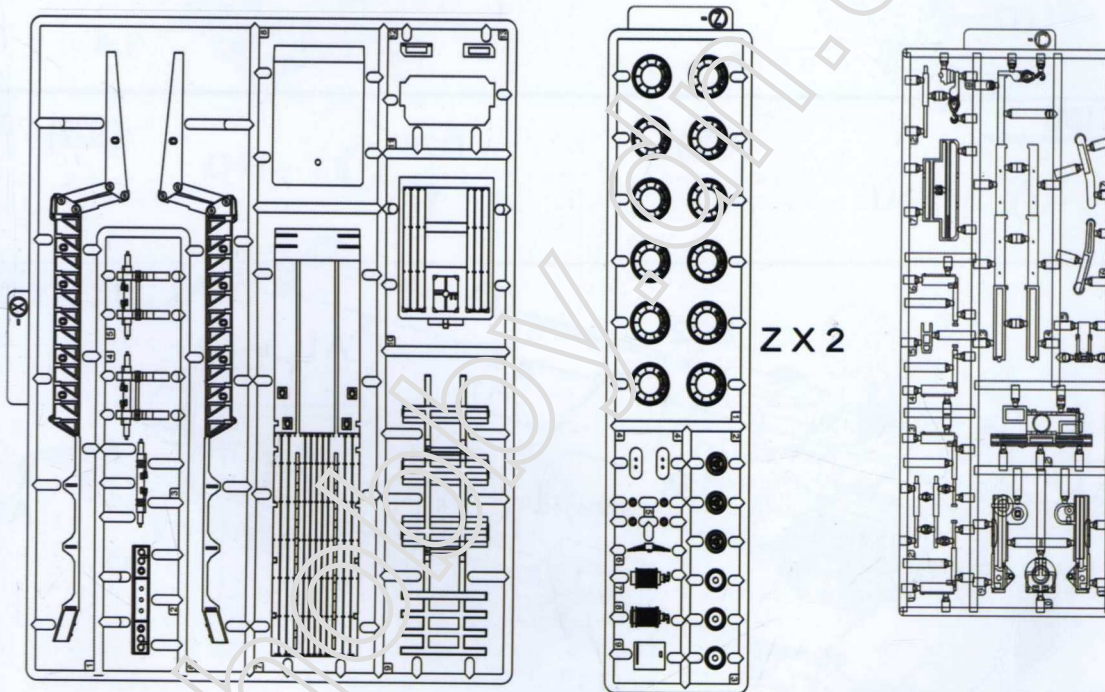
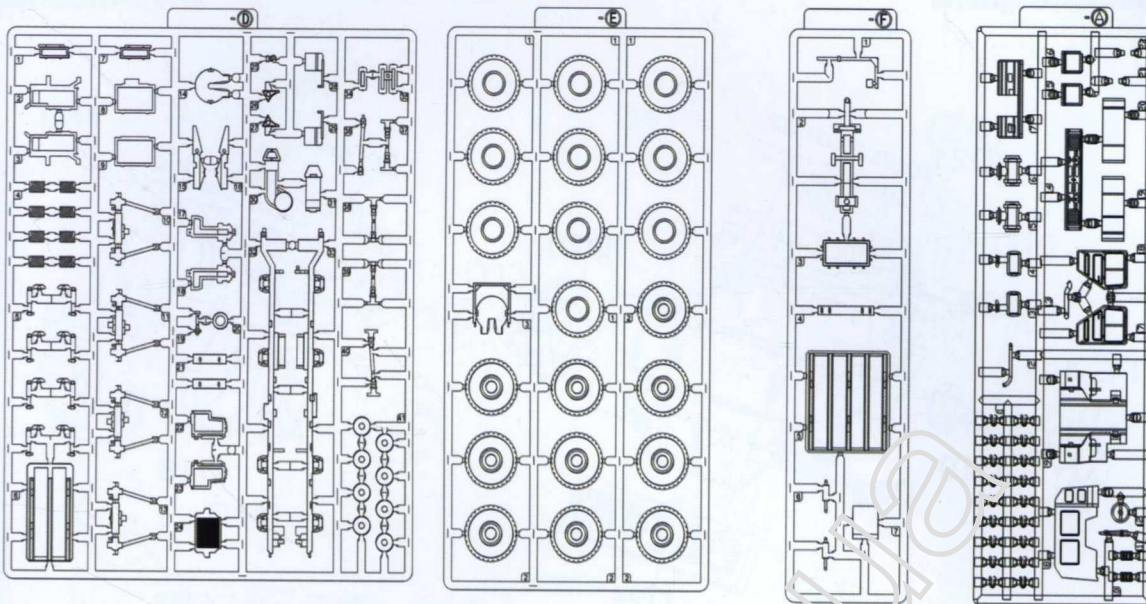

Decal

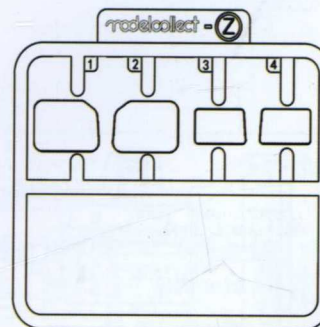
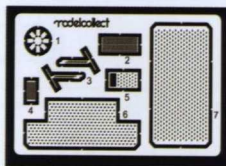

1

发动机及传动结构组装
发动机及传动结构组装
Attaching engine part and transmission system

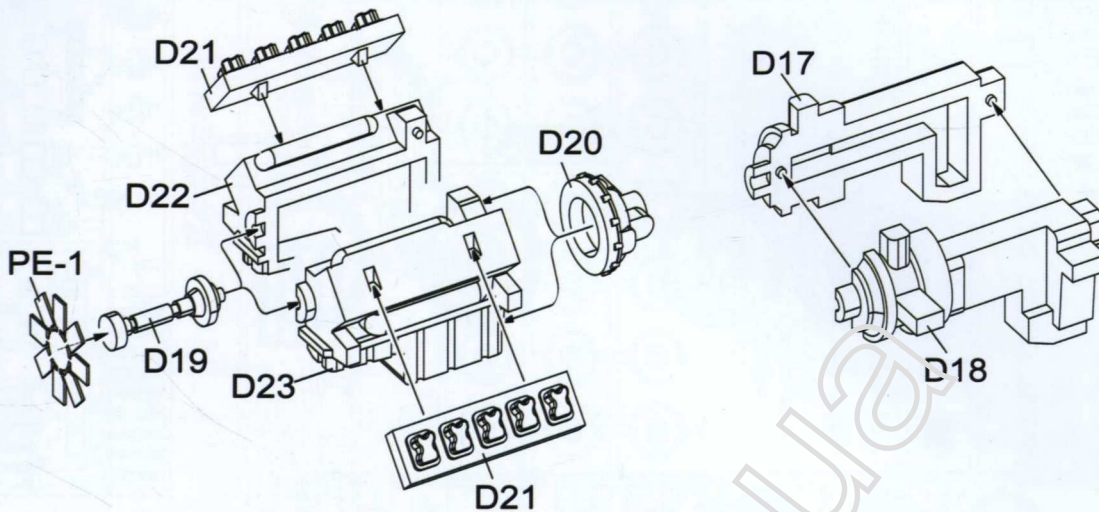

2

车体大梁附件组装
车体大梁附件组装
Attaching crossbeam detail part

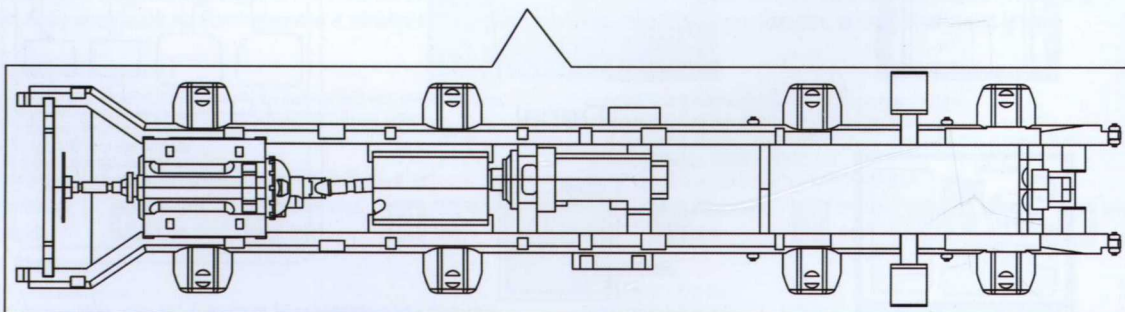
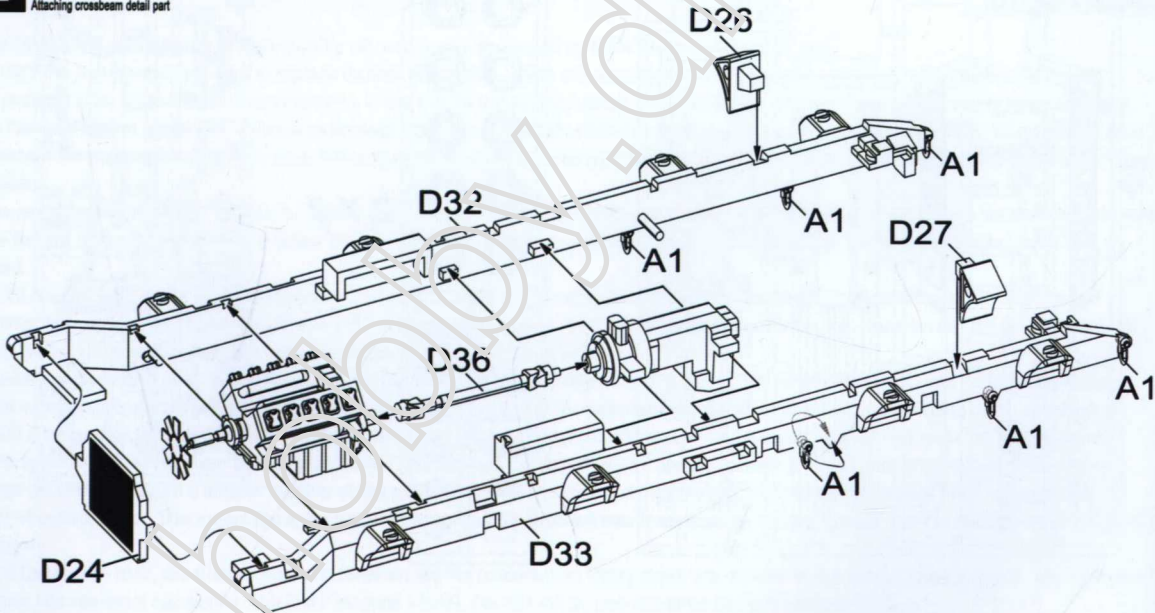

3

车体大梁及悬挂结构组装
車體大梁及懸掛結構組裝
Attaching crossbeam and suspension

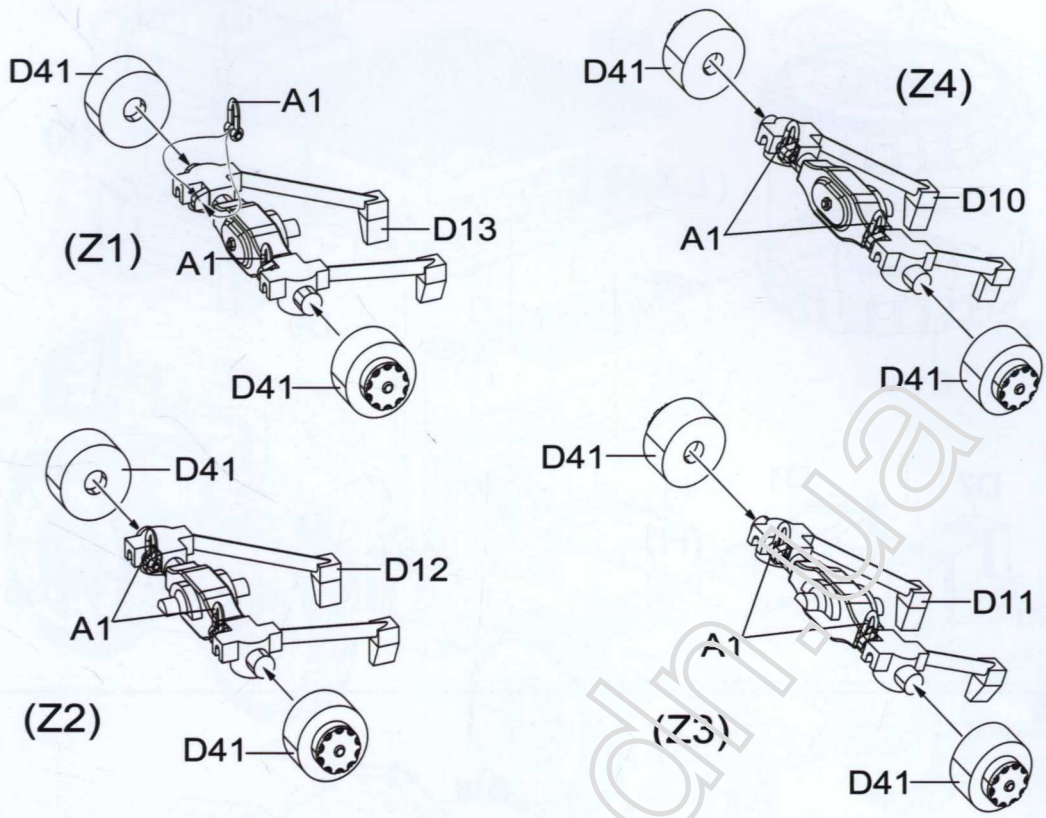

4

车体大梁及悬挂结构组装
車體大梁及懸掛結構組裝
Attaching crossbeam and suspension

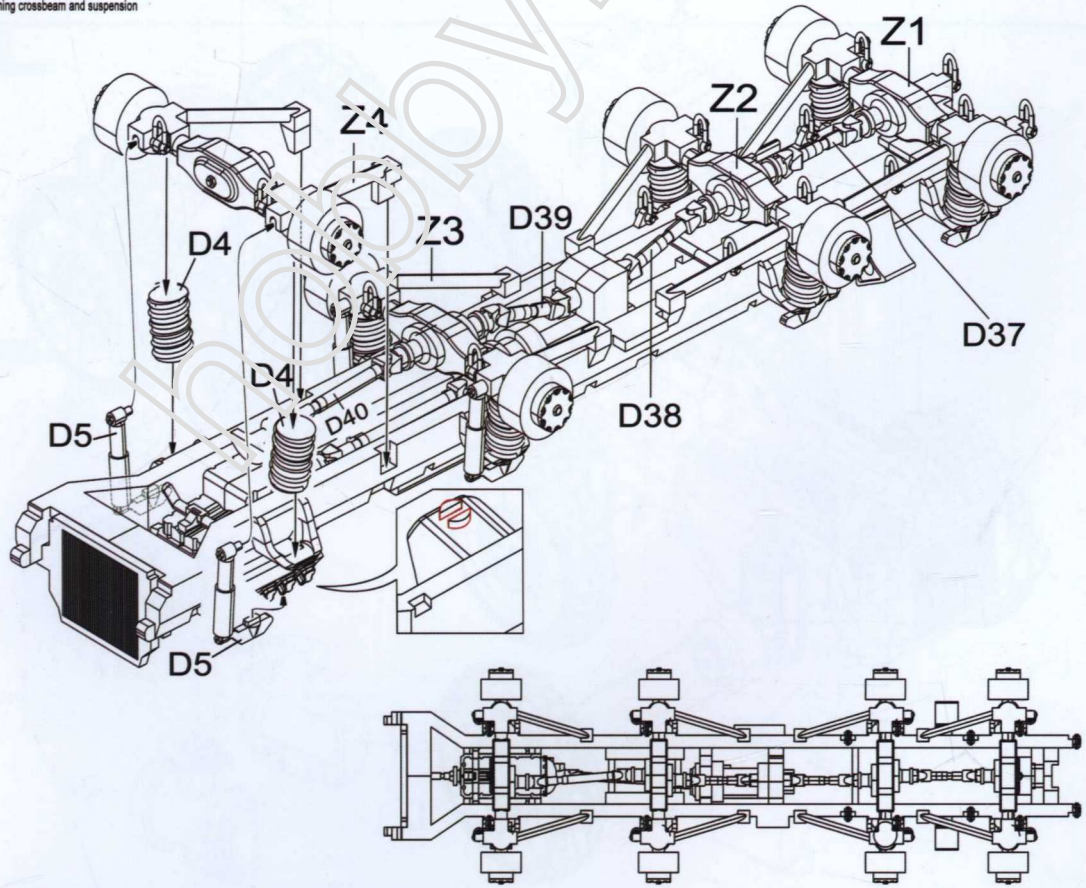

5

车体大梁附件组装
車體大梁附件組裝
Attaching crossbeam detail part

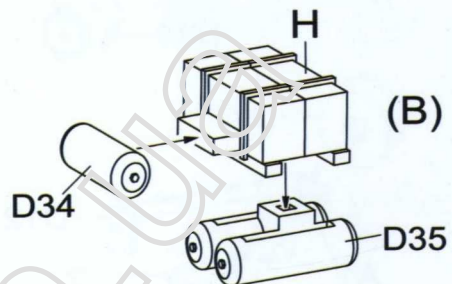
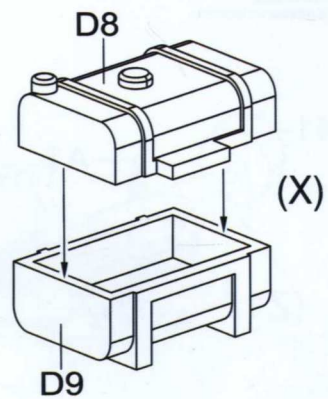
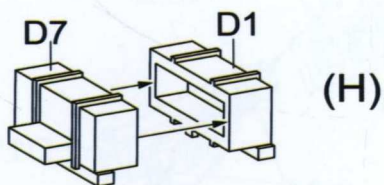
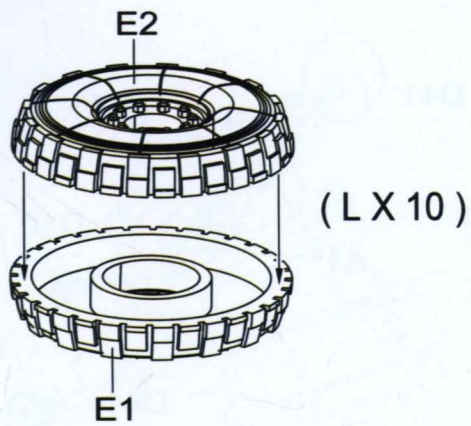

6

车体大梁附件组装
車體大梁附件組裝
Attaching crossbeam detail part

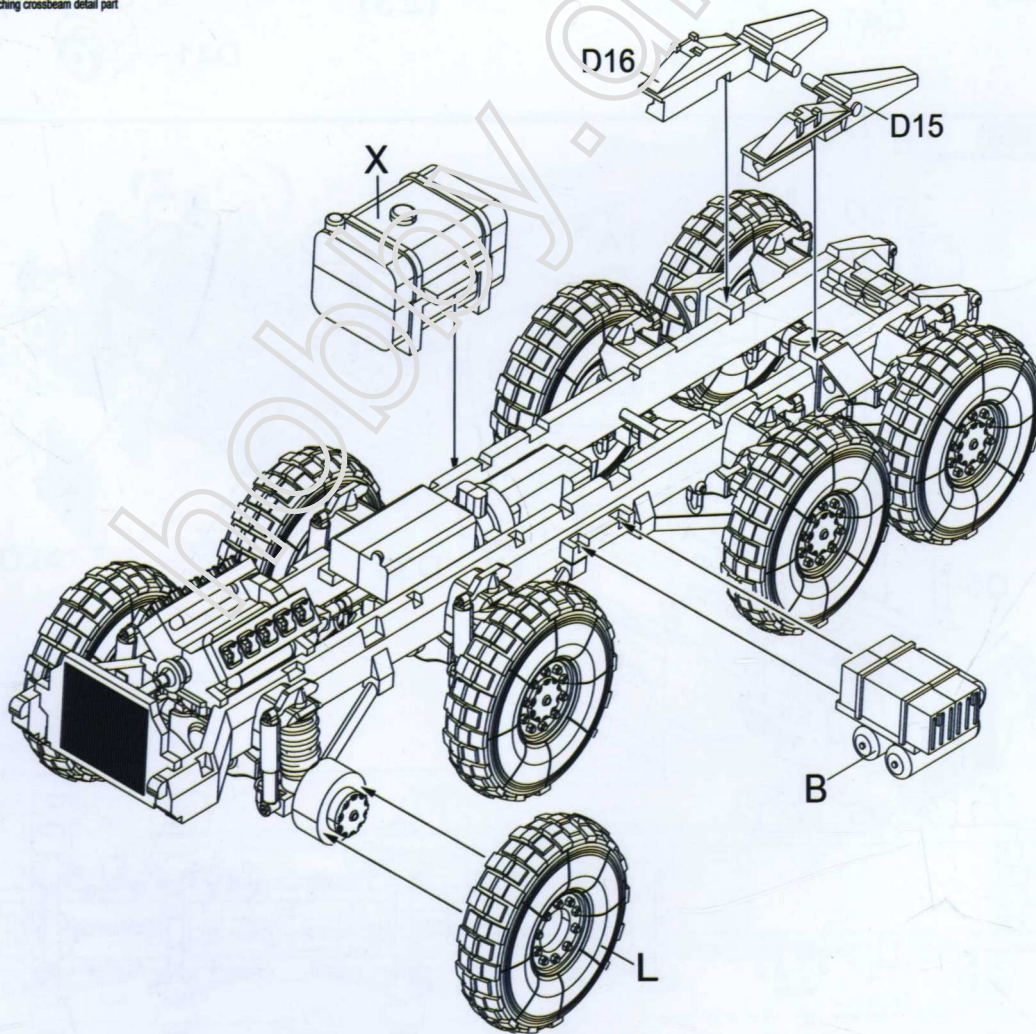

7 车体组装
車體組裝
Car body assembly

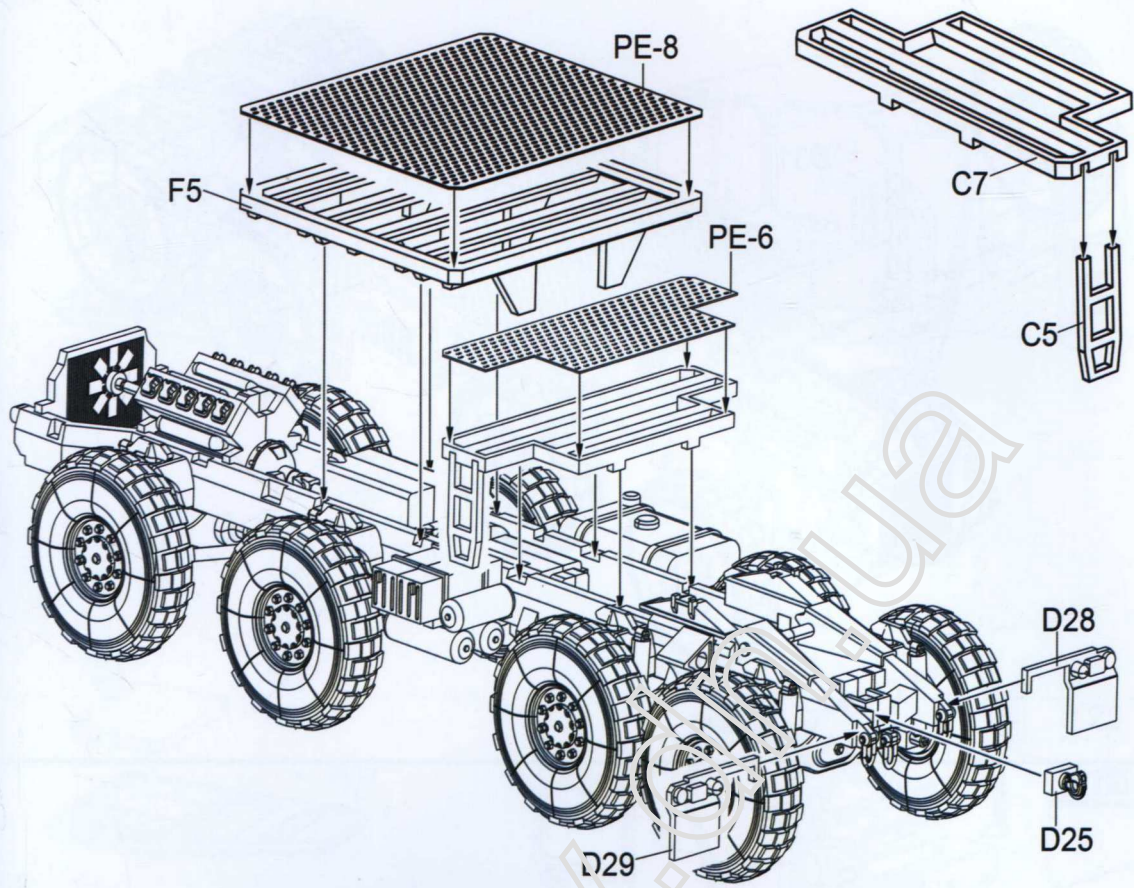

8 配件组装
配件組裝
Chassis Assembly

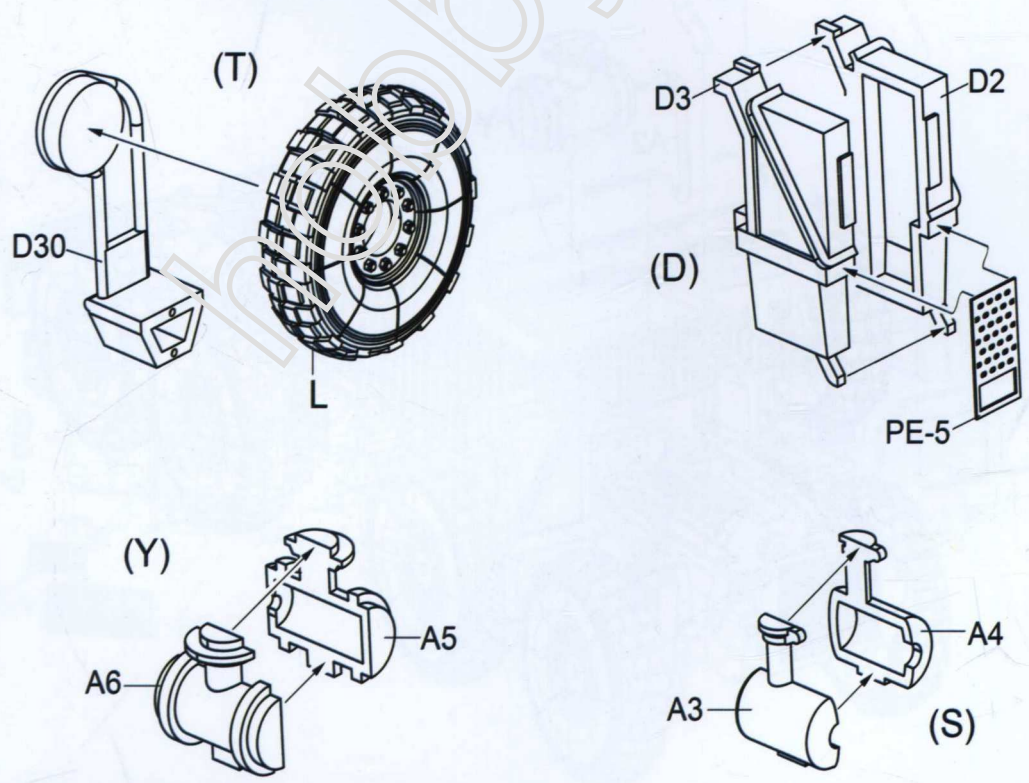

9

车体组装
車體組裝
Car body assembly

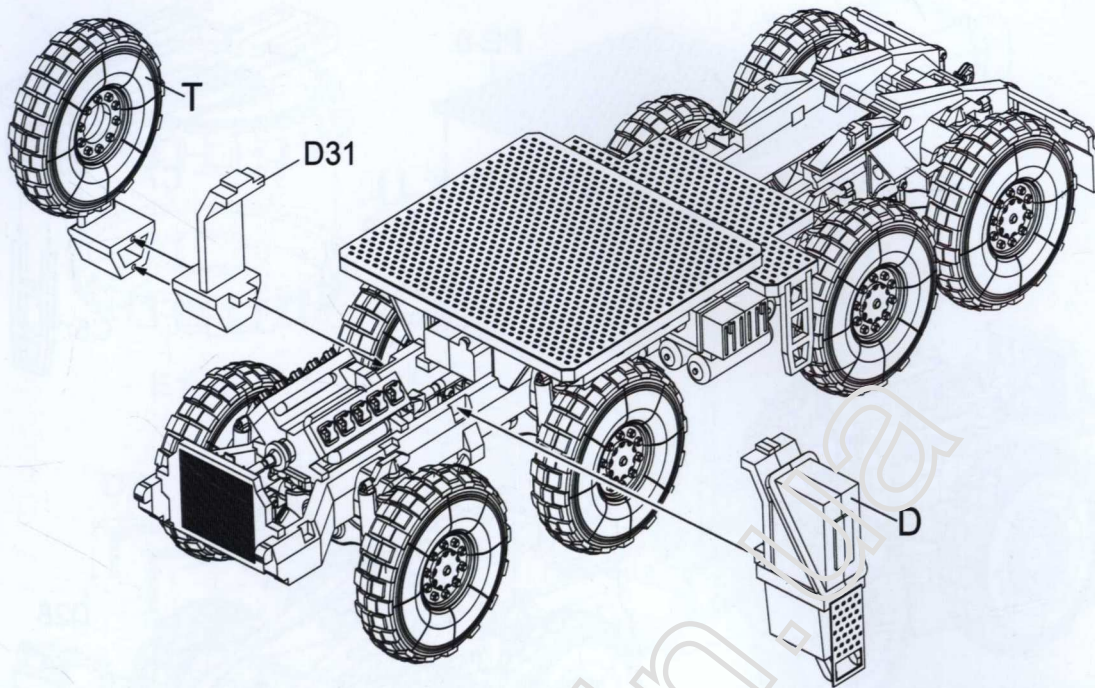

10

车体组装
車體組裝
Car body assembly

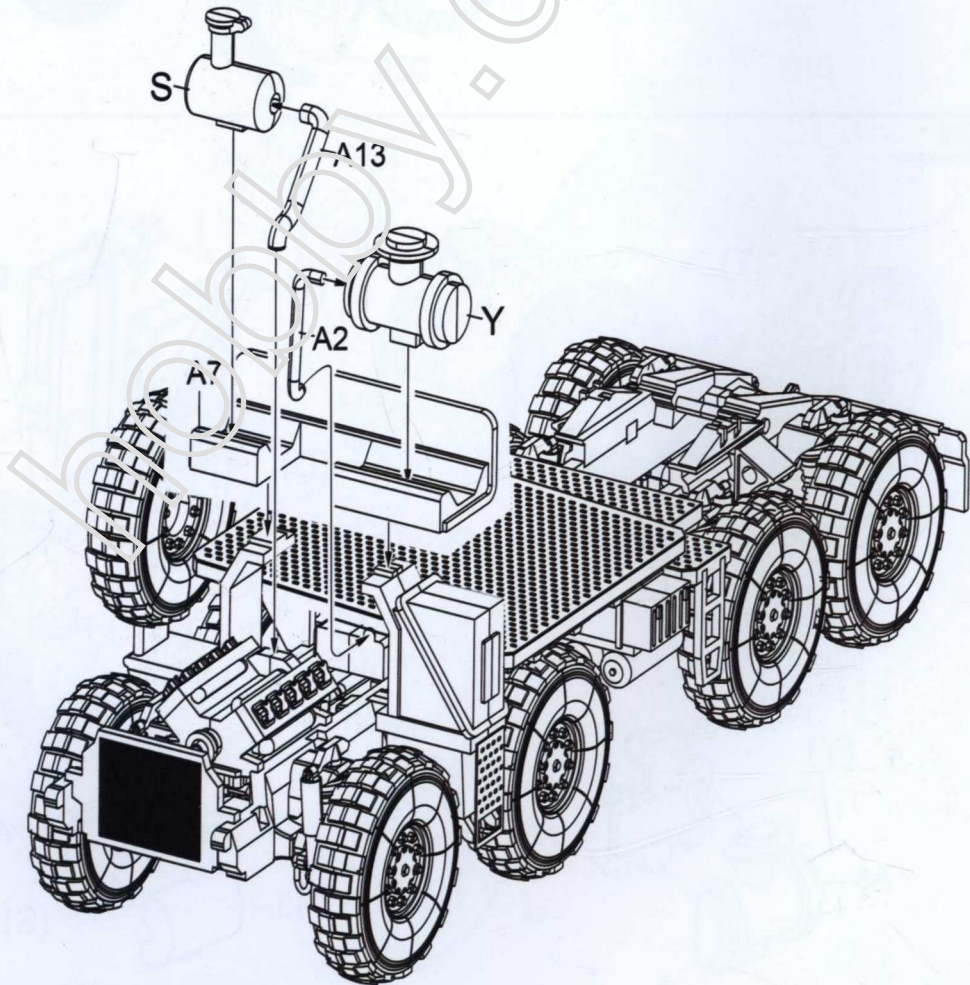

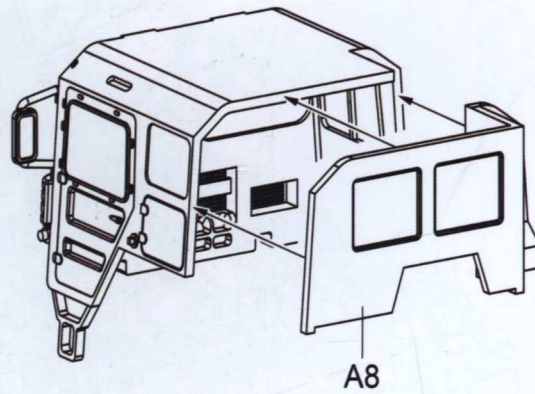
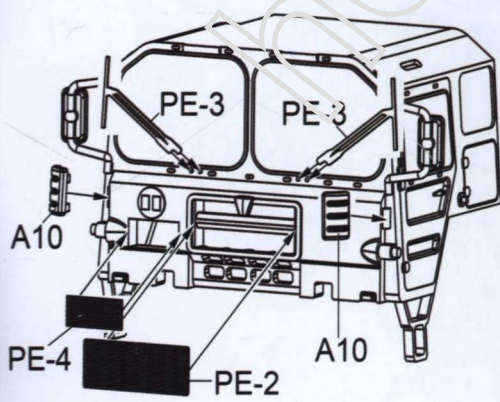
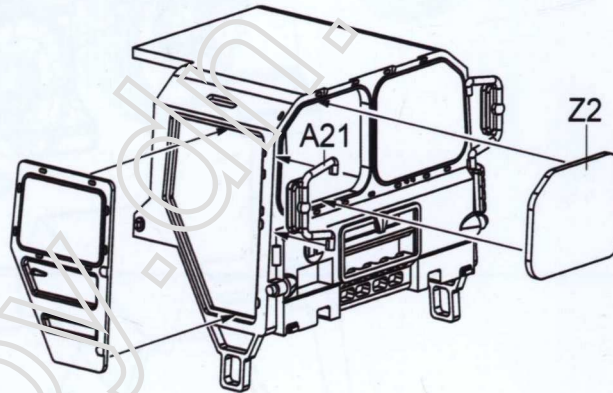
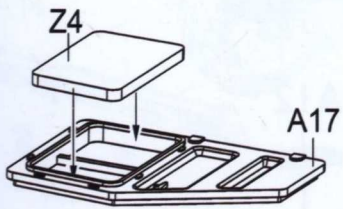
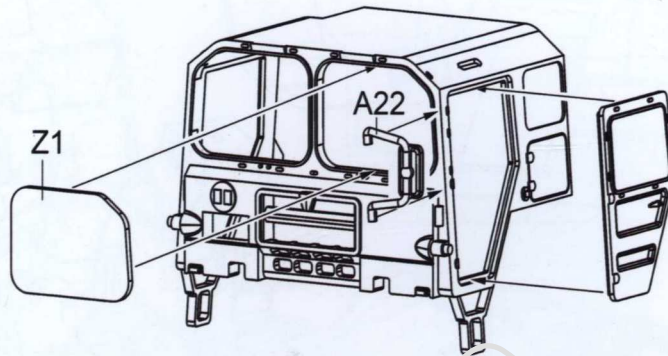
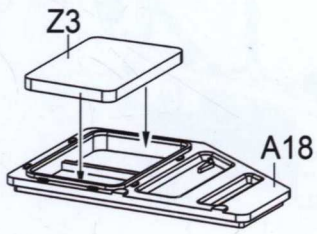

12 駕駛室組裝
駕駛室組裝
Attaching drive cabin

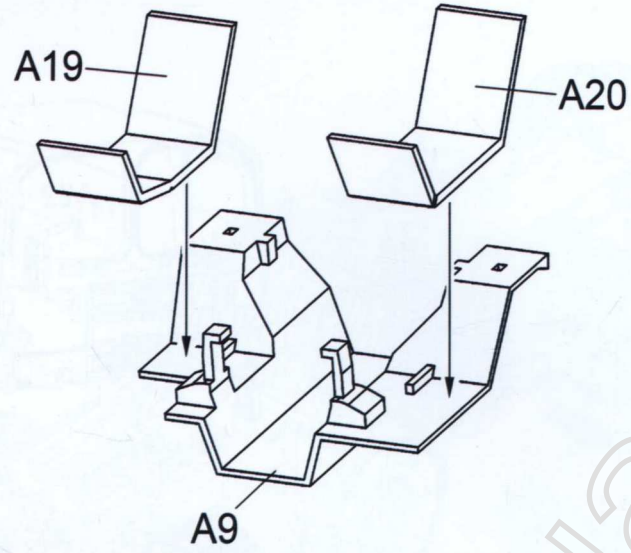

13 駕駛室組裝
駕駛室組裝
Attaching drive cabin

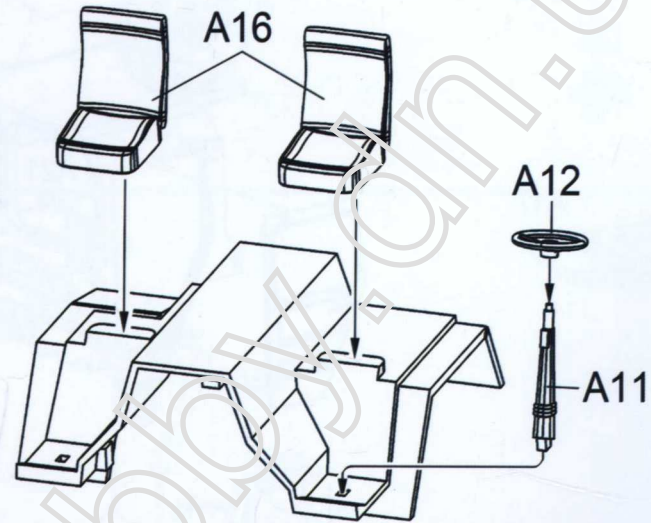

14 駕駛室組裝
駕駛室組裝
Attaching drive cabin

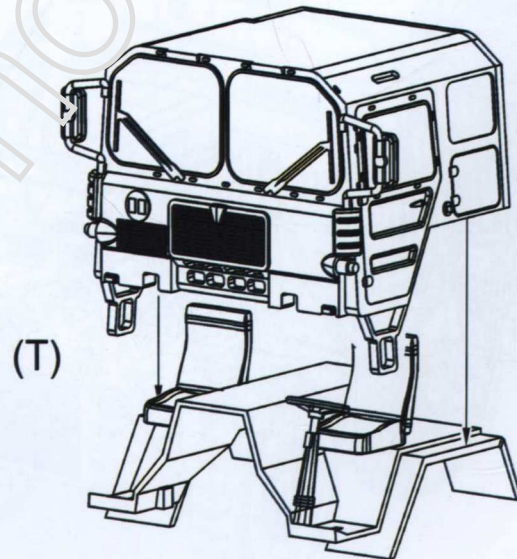

15 駕駛室組裝
駕駛室組裝
Attaching drive cabin

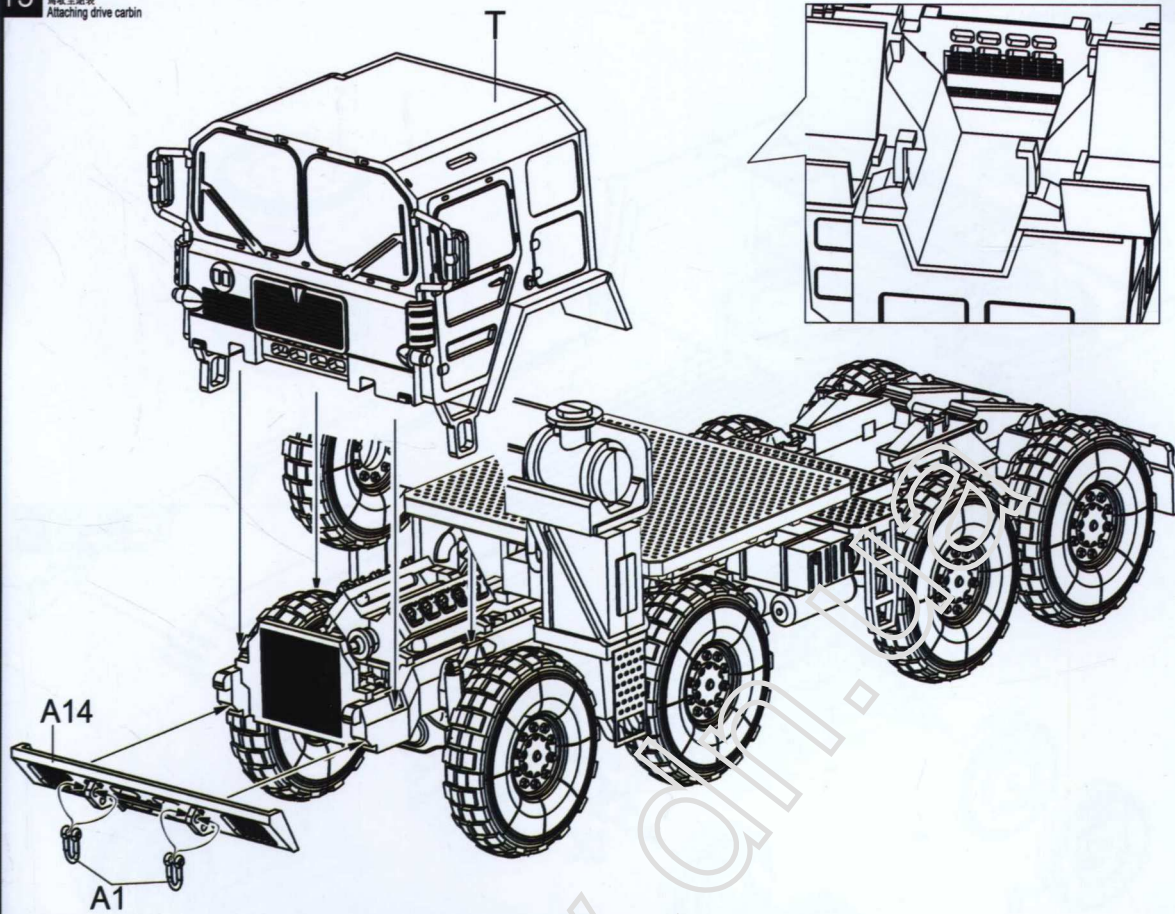

16 駕駛室組裝
駕駛室組裝
Attaching drive cabin

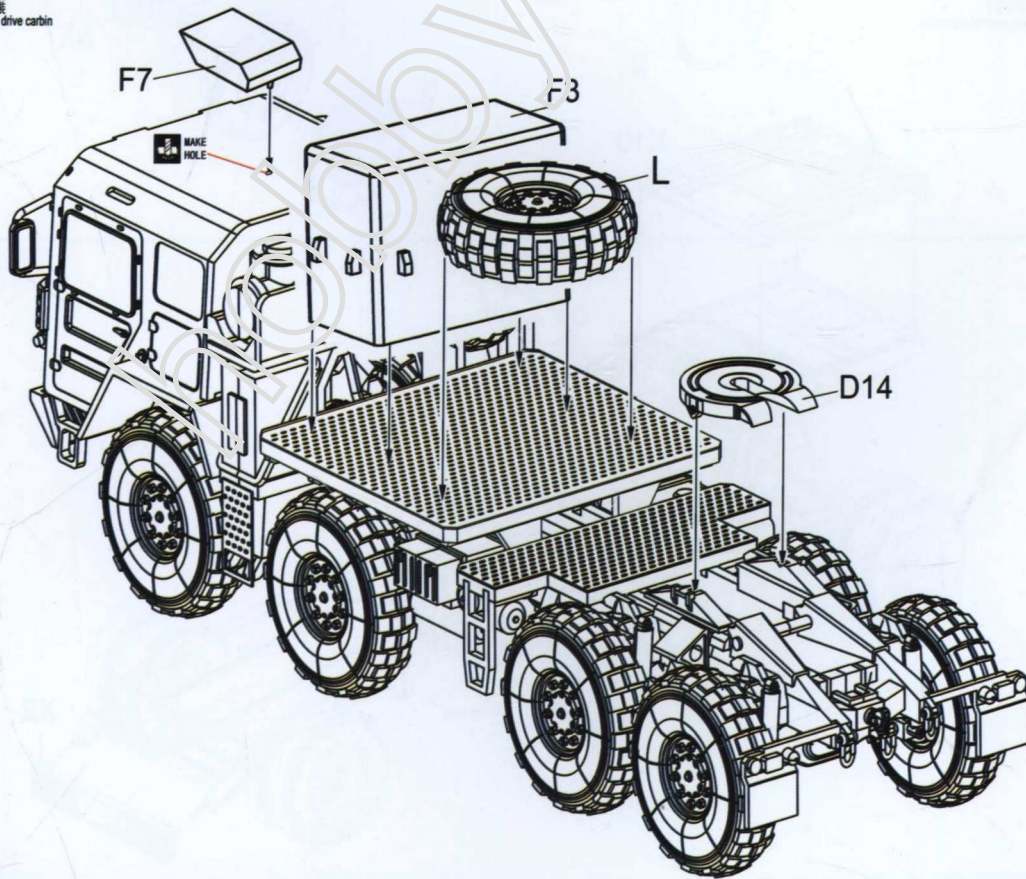

1

組裝拖車車體 1
組裝拖車車體 1
Attaching semi-trailer's body 1

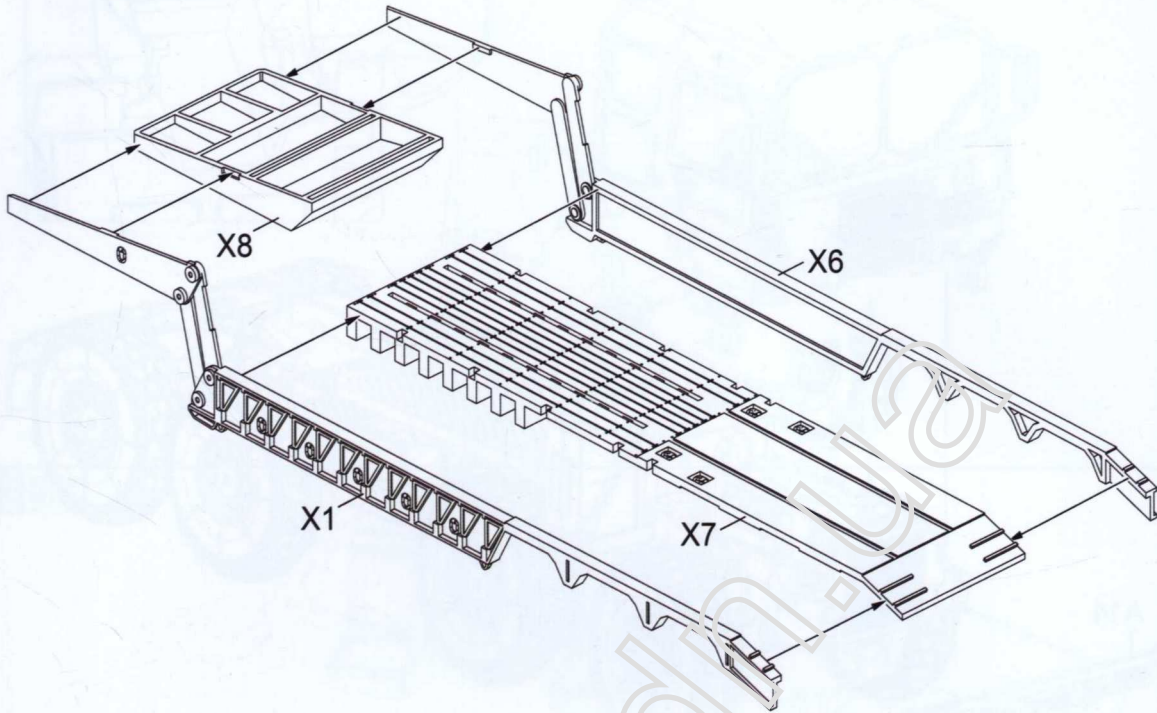

2

組裝拖車車體 2
組裝拖車車體 2
Attaching semi-trailer's body 2

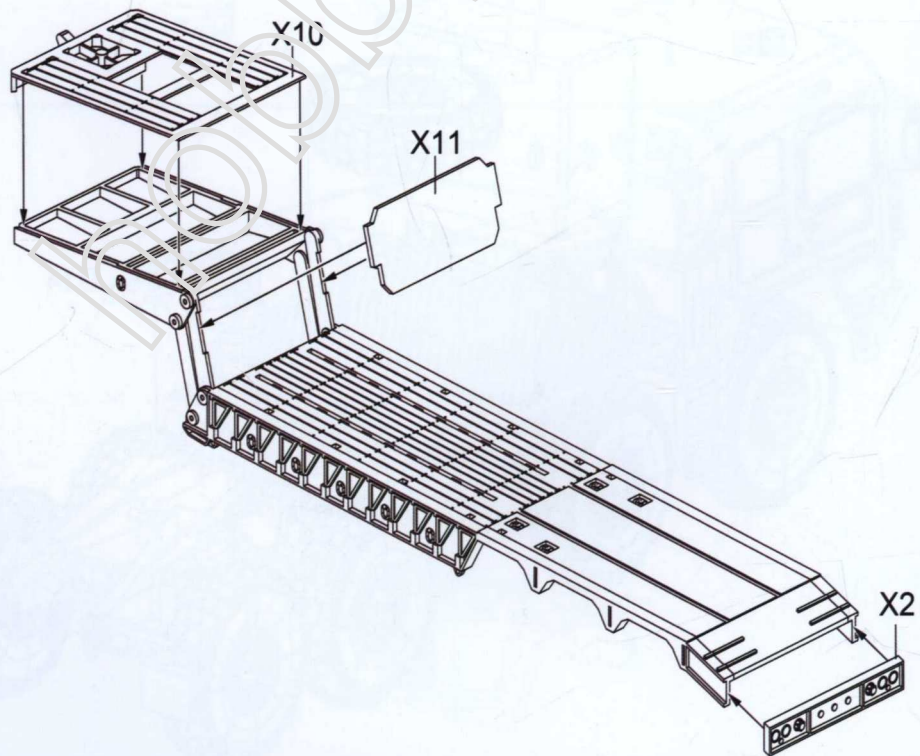

3

組裝拖車車輪
組裝拖車車輪
Attaching wheels

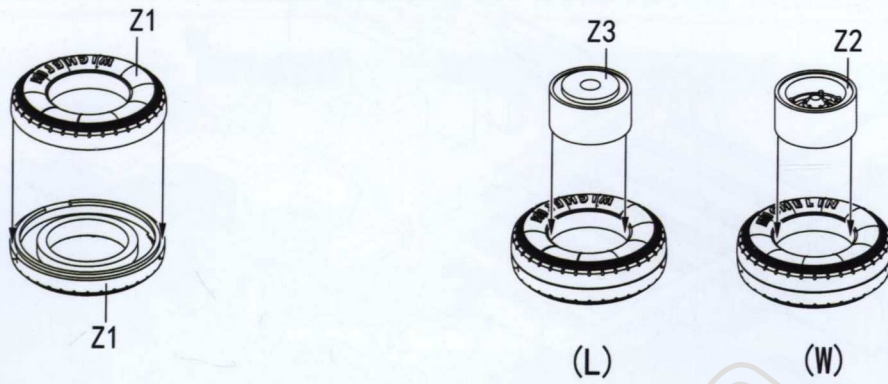

4

組裝拖車懸掛結構 1
組裝拖車懸掛結構 1
Attaching suspension 1

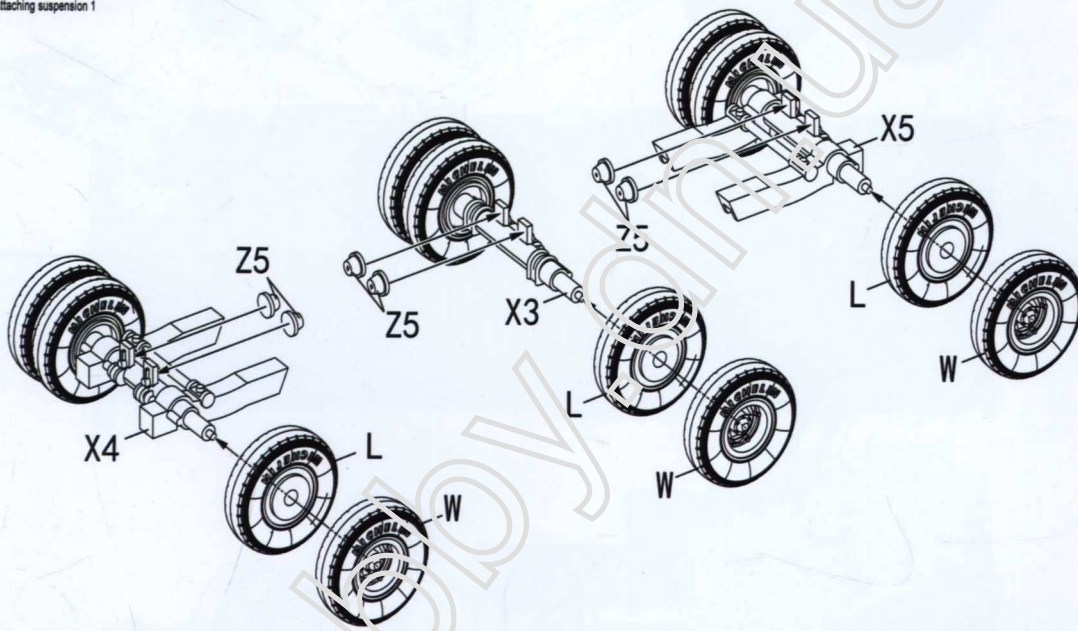

5

組裝拖車懸掛結構 2
組裝拖車懸掛結構 2
Attaching suspension 2

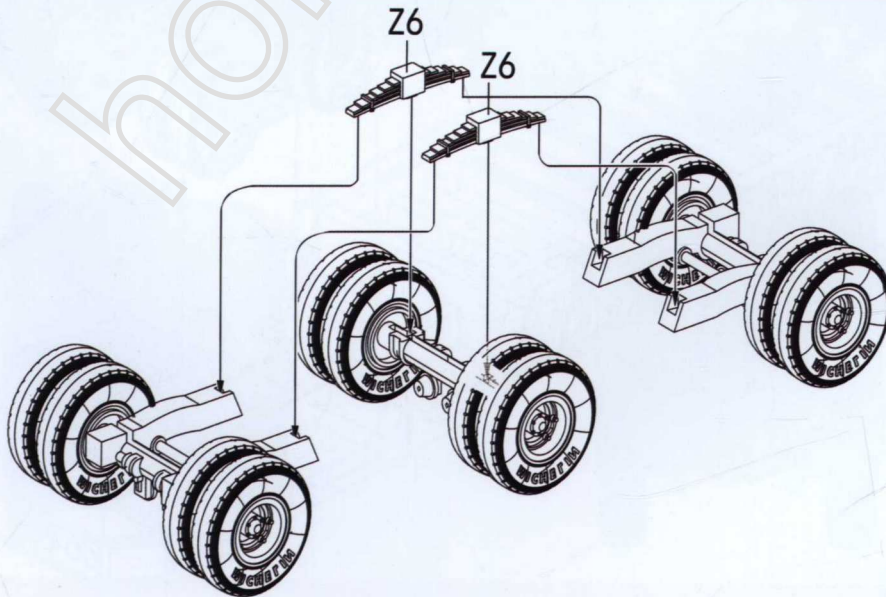

6

組裝拖車懸掛結構 3
組裝拖車懸掛結構 3
Attaching suspension 3

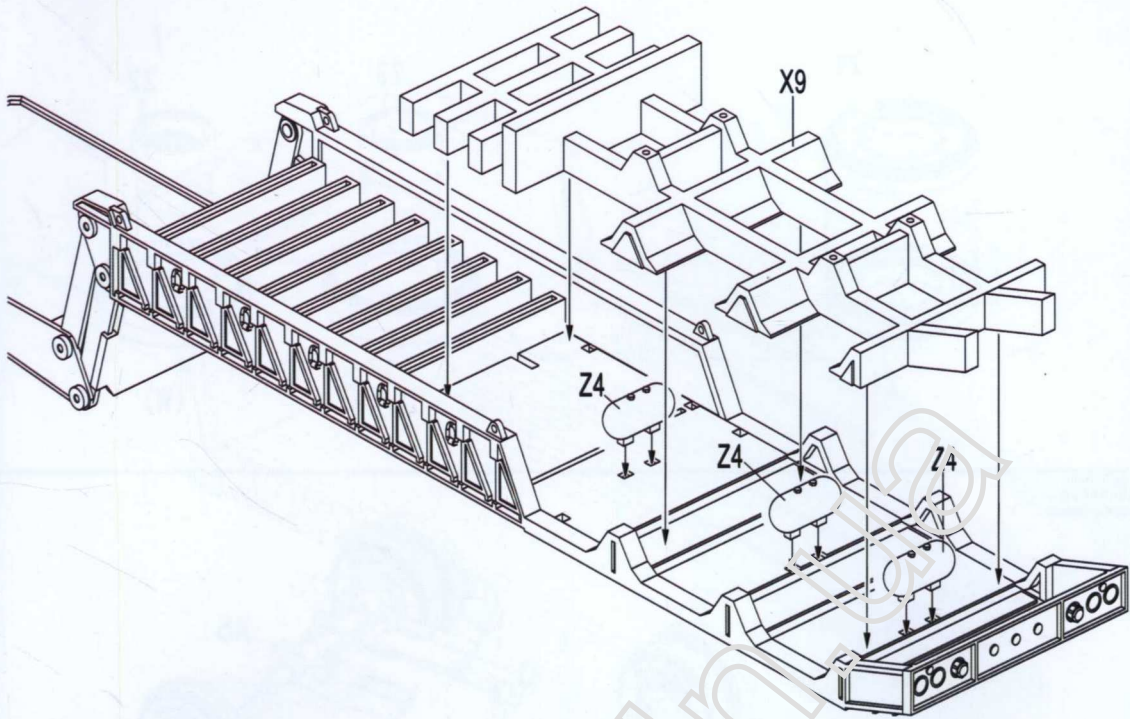

7

組裝拖車懸掛結構 4
組裝拖車懸掛結構 4
Attaching suspension 4

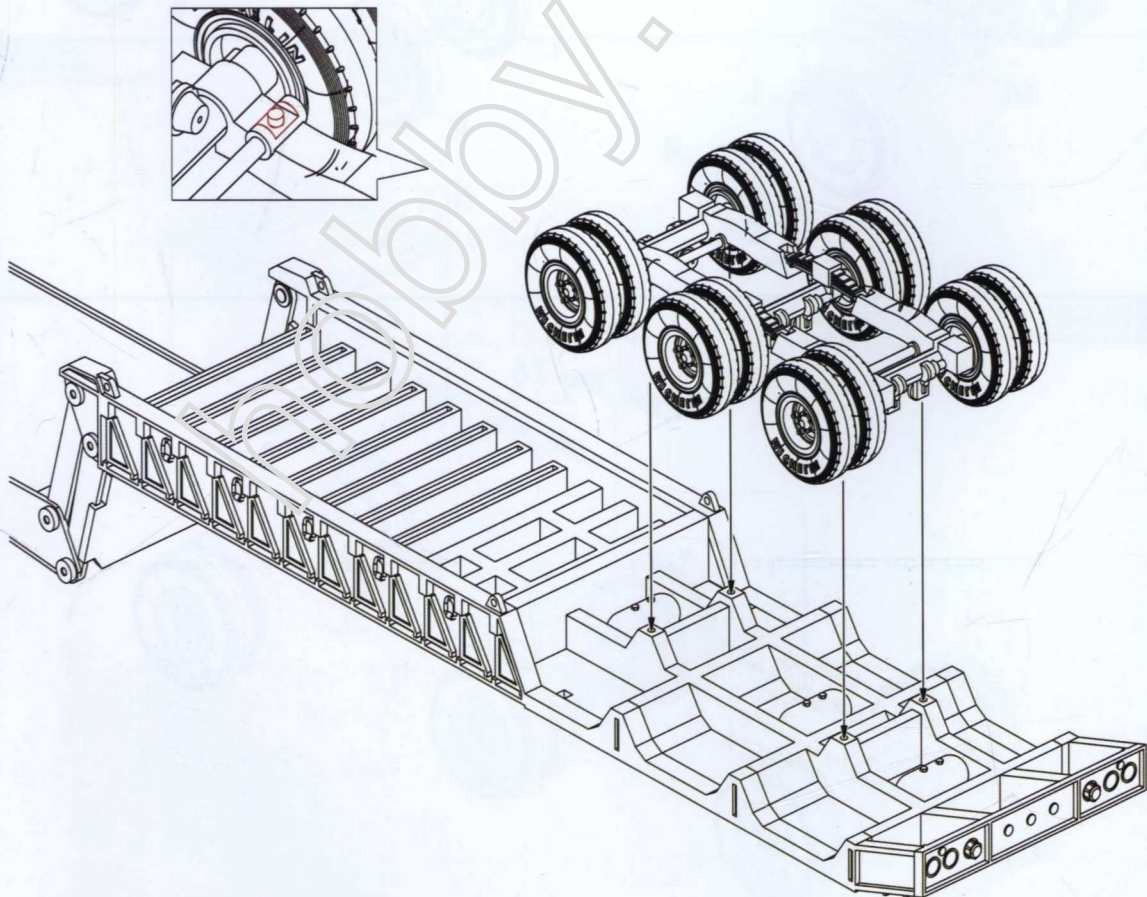

WITH M870A1 SEMI-TRAILER GERMAN MAN KAT1M1014 8*8 HIGH-MOBILITY OFF-ROAD TRUCK



- A.MIG 033 Rubber & Tires
- A.MIG 097 Crystal Orange
- A.MIG 083 ZASHCHITNIY ZELENO
- A.MIG 057 Yellow Grey
- A.MIG 047 Satin White
- A.MIG 0191 Steel
- A.MIG 187 JET EXHAUST BURNT IRON
- A.MIG 046 Matt Black

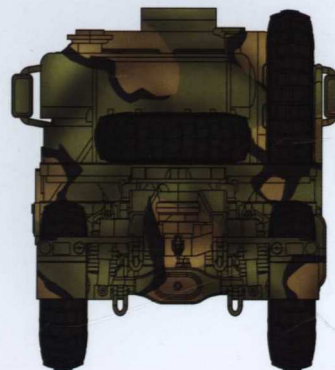
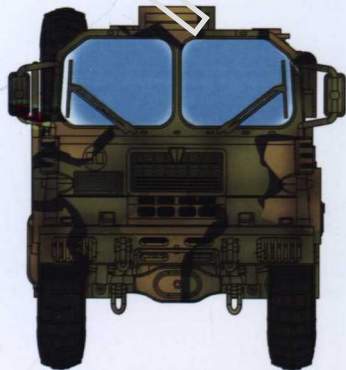
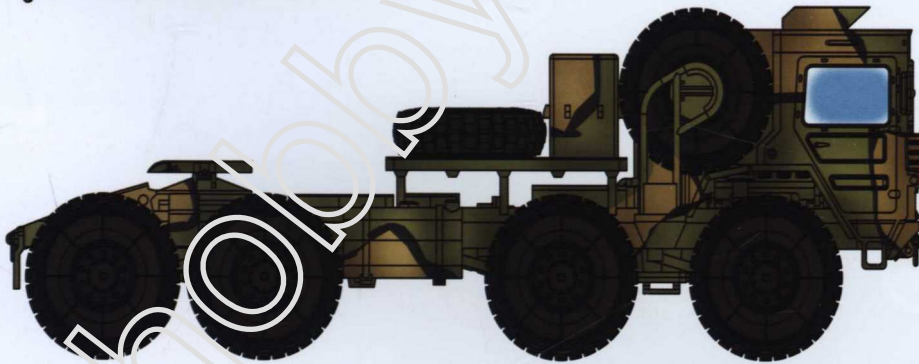
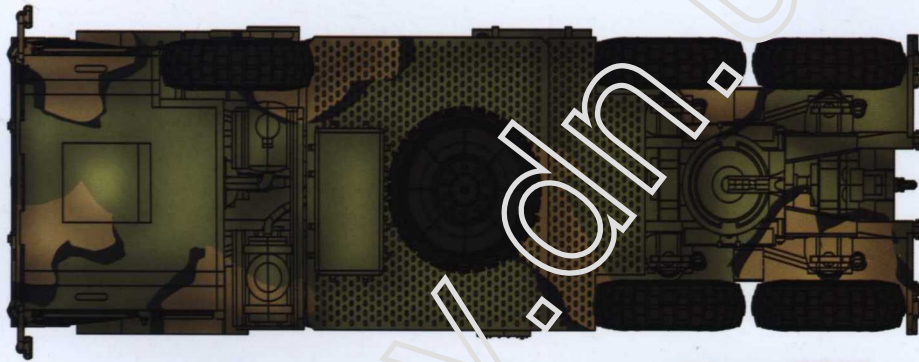
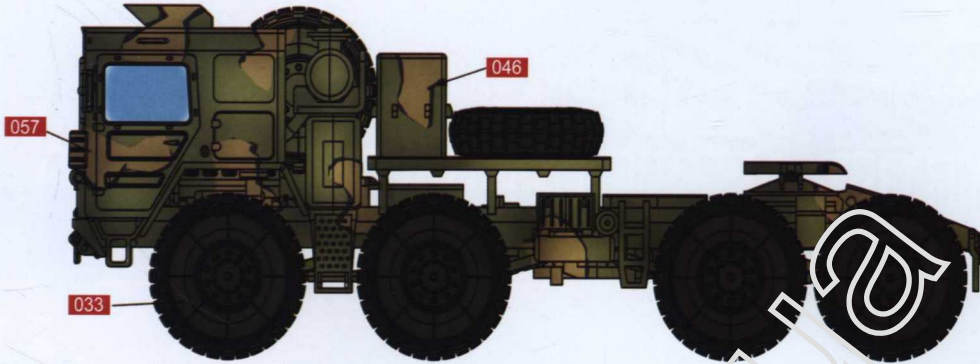

GERMAN MAN KAT1 M1014 8*8 HIGH-MOBILITY OFF-ROAD TRUCK

WITH M870A1 SEMI-TRAILER



- A.MIG 033 Rubber & Tires
- A.MIG 097 Crystal Orange
- A.MIG 056 Green Khaki
- A.MIG 057 Yellow Grey
- A.MIG 047 Satin White
- A.MIG 0191 Steel
- A.MIG 187 JET EXHAUST BURNT IRON
- A.MIG 046 Matt Black

