

GERMANY WWII E-75 HEAVY TANK WITH 128MM FLAK 40 GUN

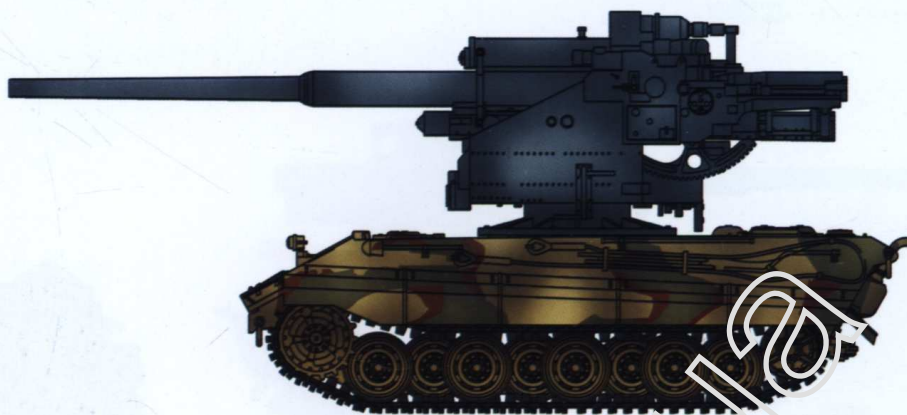

ITEM NO:UA72136

Delivered for testing in late 1937 and completed testing successfully. The gun weighed nearly 12 tonnes in its firing position, with the result that its barrel had to be removed for transport. Limited service testing showed this was impractical, so in 1938 other solutions were considered.

The eventual solution was to simplify the firing platform, based on the assumption it would always be securely bolted into concrete. The total weight of the Flakzwillig twin-gun mount system reached 29.5 tonnes, making it practically impossible to tow cross-country. In the end, this mattered little since by the time the gun entered production in 1942, it was used in primary static defensive applications. There were four twin mounts on the fortified anti-aircraft Zoo Tower, and they were also on other flak towers protecting Berlin, Hamburg, and Vienna. During the Battle of Berlin, the guns on the Zoo Tower were used successfully to support ground forces, where the heavy 128 mm shells obliterated Soviet armor, especially when hit from the side. The rush to capture the Reichstag led to dozens of tanks being destroyed. Approximately 200 were immobilized on railcars, providing limited mobility.

The gun fired a 27.9 kg (57.2-pound) shell at 880 m/s (2,890 ft/s) to a maximum ceiling of 14,800 m (48,556 ft). Compared with the 88 mm FlaK 18 & 36, the FlaK 40 used a powder charge four times as great.

●READ BEFORE ASSEMBLY

1. When you use glue or paint, do not near flame, and use in a well-ventilated room.
2. Take extra care in handling private each parts in order to avoid injury
3. When you take parts off the runner frame, use modeling scissors and trim excess plastic with a cutter or a file.
4. Glue and paint are not included.
5. This product is only suitable for experienced more than 14 years old.

●装配之前仔细阅读:

1. 勿於近火处使用胶水或油漆, 并 打开窗户保持空气流通。
2. 取蚀刻片时应特别注意安全, 防止利边划伤手指。
3. 从胶架中取出部件时, 应用模型专用剪, 并用界刀或小锉除去多余的胶料。
4. 请使用塑料胶水和油漆, 模型内不含。
5. 本产品不适合14岁以下没有经验的模型爱好者。

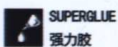

SUPERGLUE
强力胶

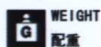

WEIGHT
配重

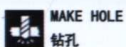

MAKE HOLE
钻孔

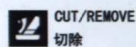

CUT/REMOVE
切除



BEND
弯曲



FILE/SAND
锉平

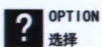

OPTION
选择

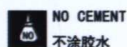

NO CEMENT
不涂胶水



DECAL
贴纸

DECAL APPLICATION

1. Cut off decal from sheet.
2. Dip the decal in tepid water 40° C for about 10 sec. and place on a clean cloth.
3. Hold the backing sheet edge and slide decal onto the model.
4. Move decal into position by wetting decal with finger.
5. Press decal gently down with a soft cloth until excess water and air bubbles are gone.

水贴纸的使用:

1. 从水贴纸上剪下印花。
2. 将印花放入温水中浸10秒, 然后放在干净布上。
3. 拿着印花纸板将印花移到模型上。
4. 手指蘸水将印花移到适当的位置。
5. 用软布轻压印花直至不干, 气泡消失。

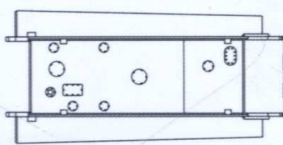
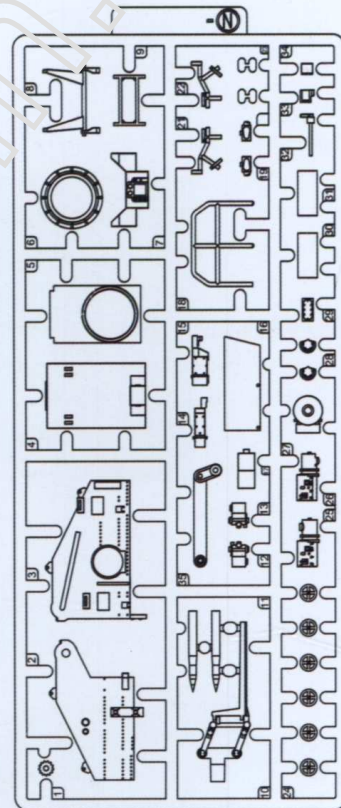
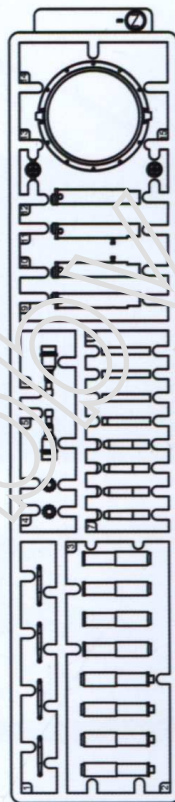
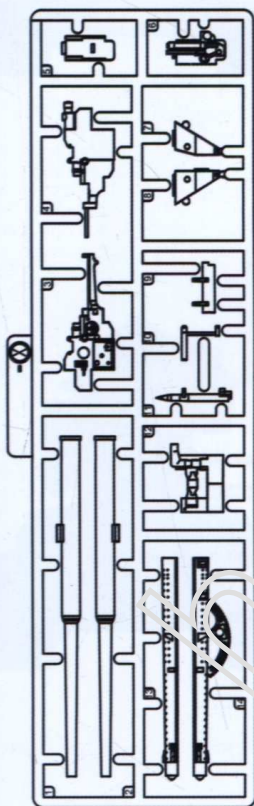
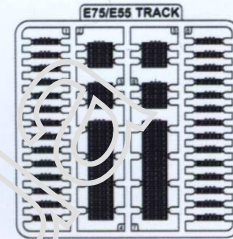
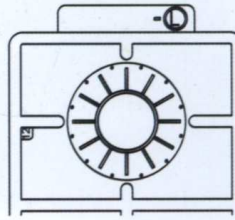
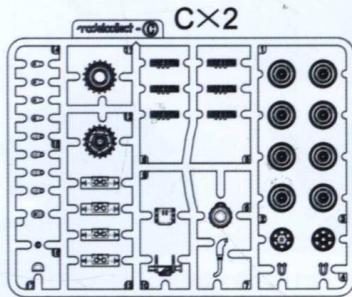
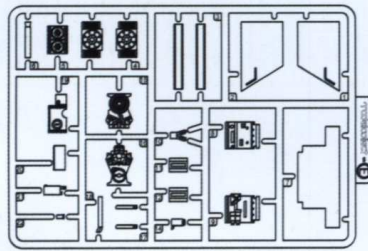
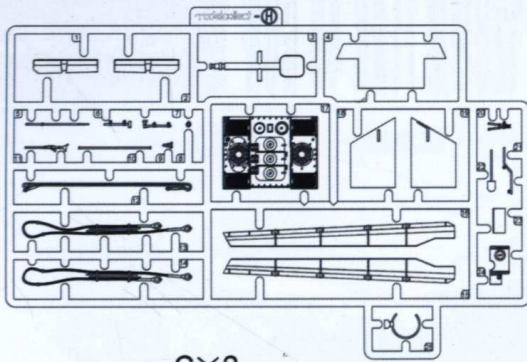

Lower hull

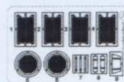
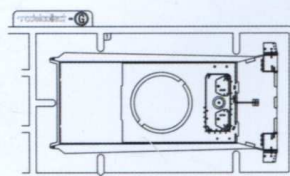

PE

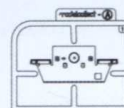

Decal

1 attaching the flak 40 gun barrel 1

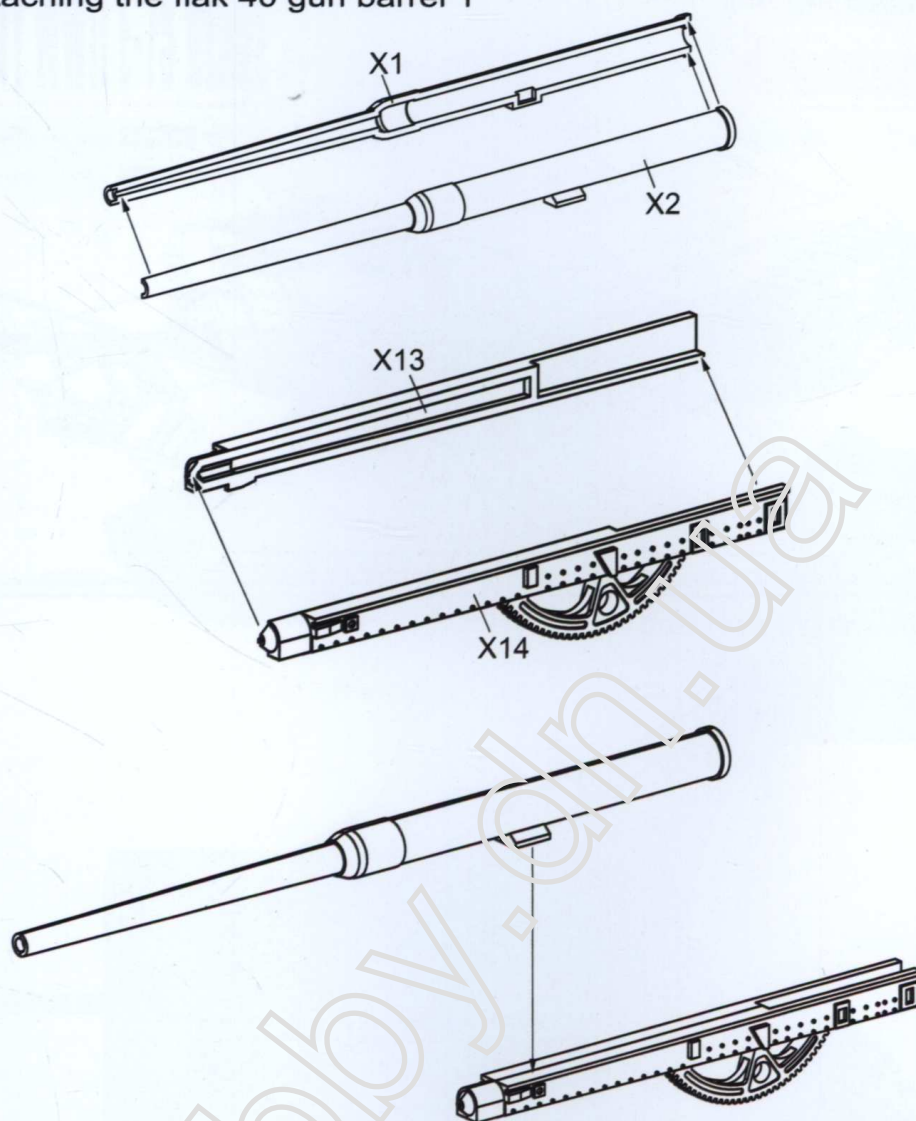

2 attaching the flak 40 gun barrel 2

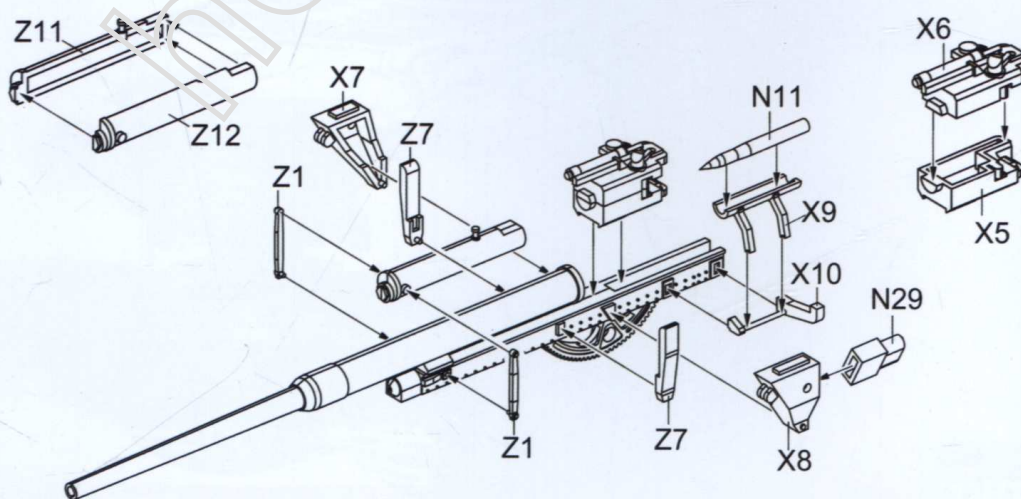

3 attaching the flak 40 gun barrel 3

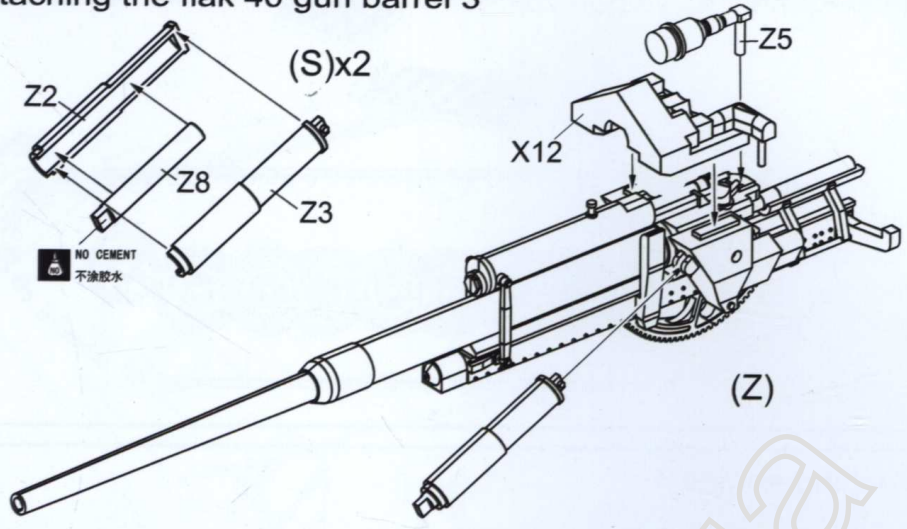

4 attaching the gun platform

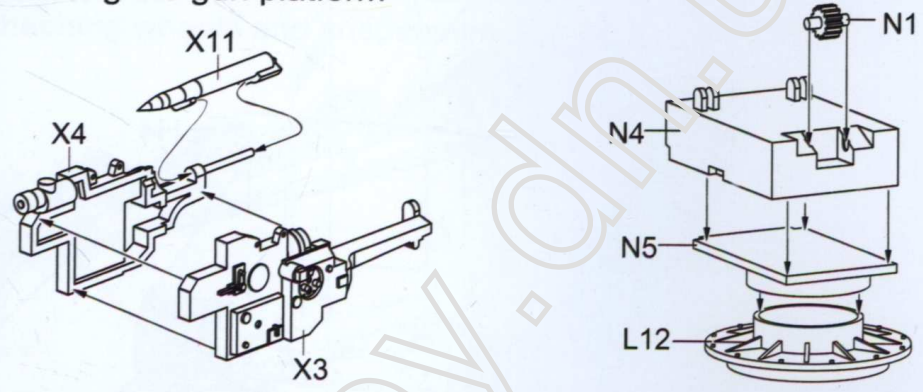

5 attaching the flak 40 gun barrel

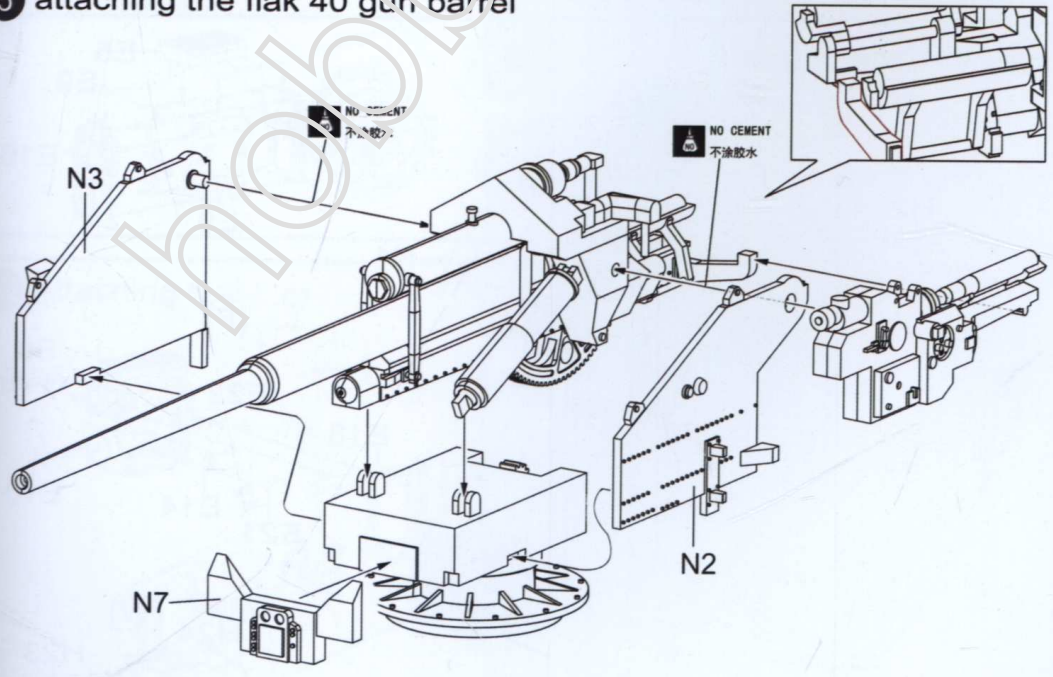

6 attaching the gun platform 1

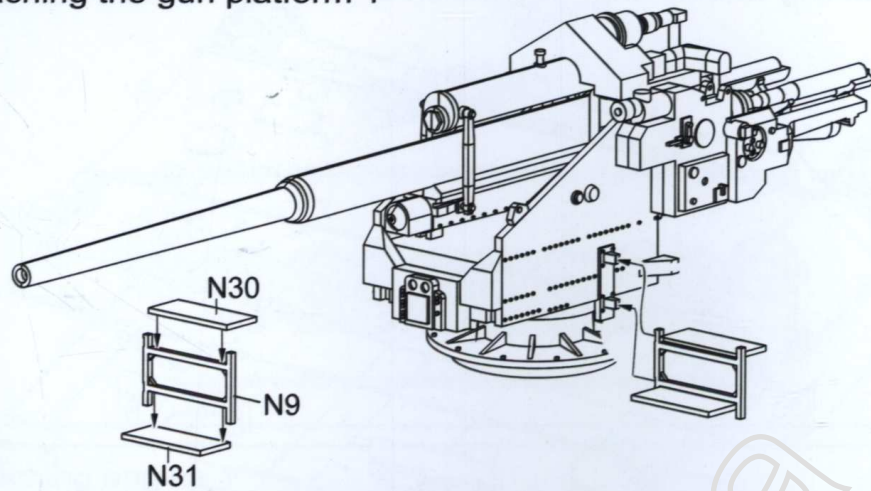

7 attaching the gun platform 2

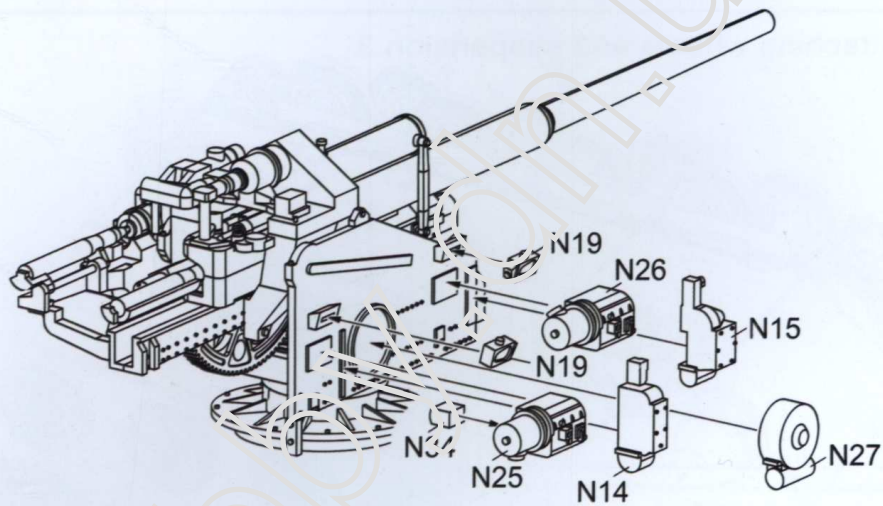

8 attaching the gun platform 3

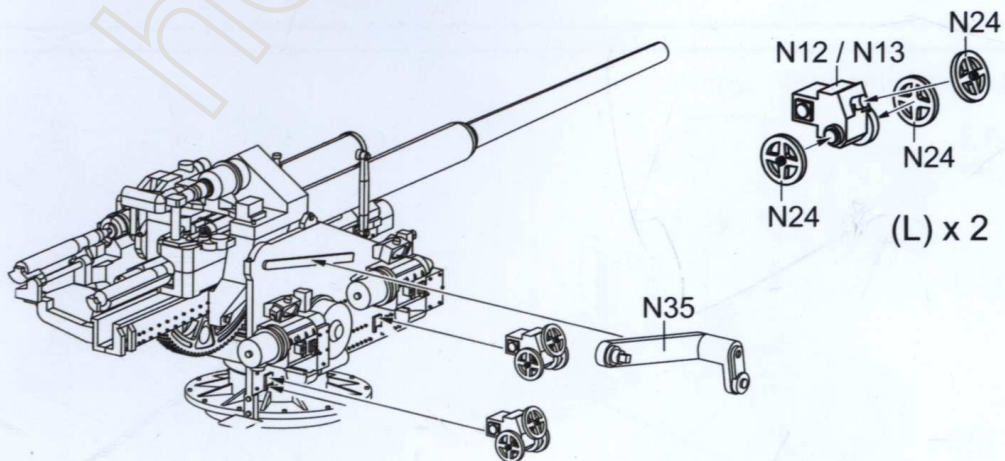

9 Attaching hull 1

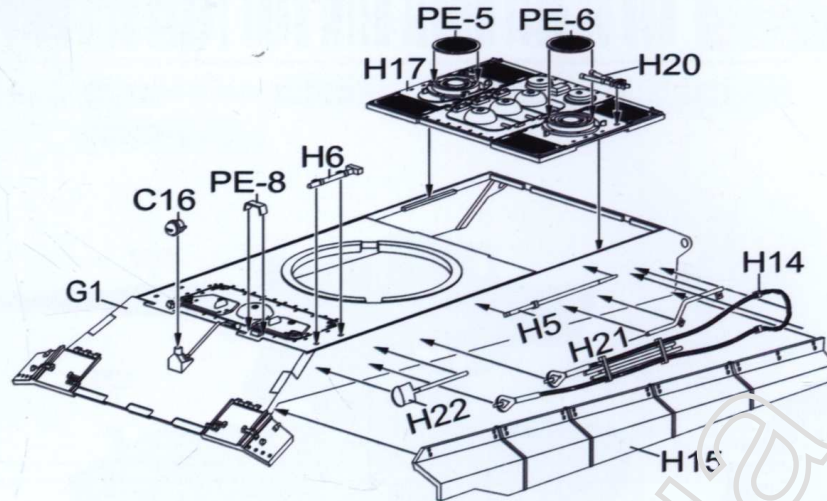

10 Attaching hull 2

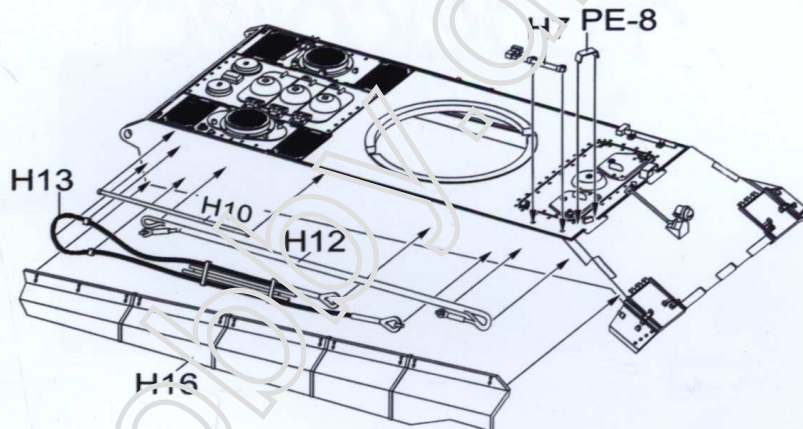

11 Attaching wheels and suspension 1

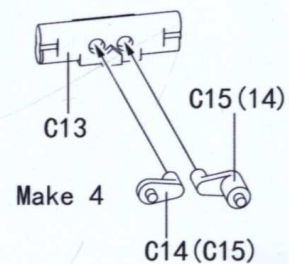
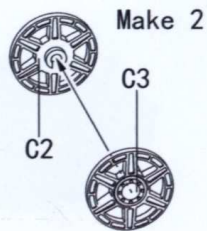
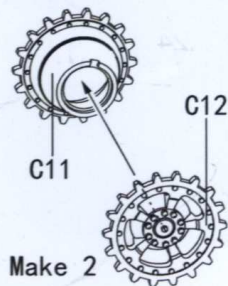

12 Attaching wheels and suspension 2

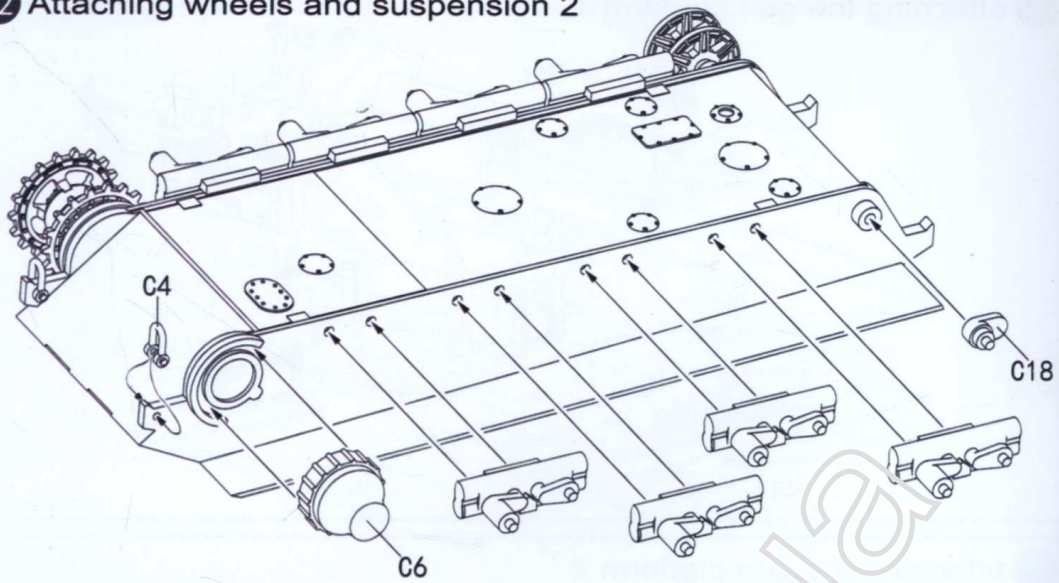

13 Attaching wheels and suspension 3

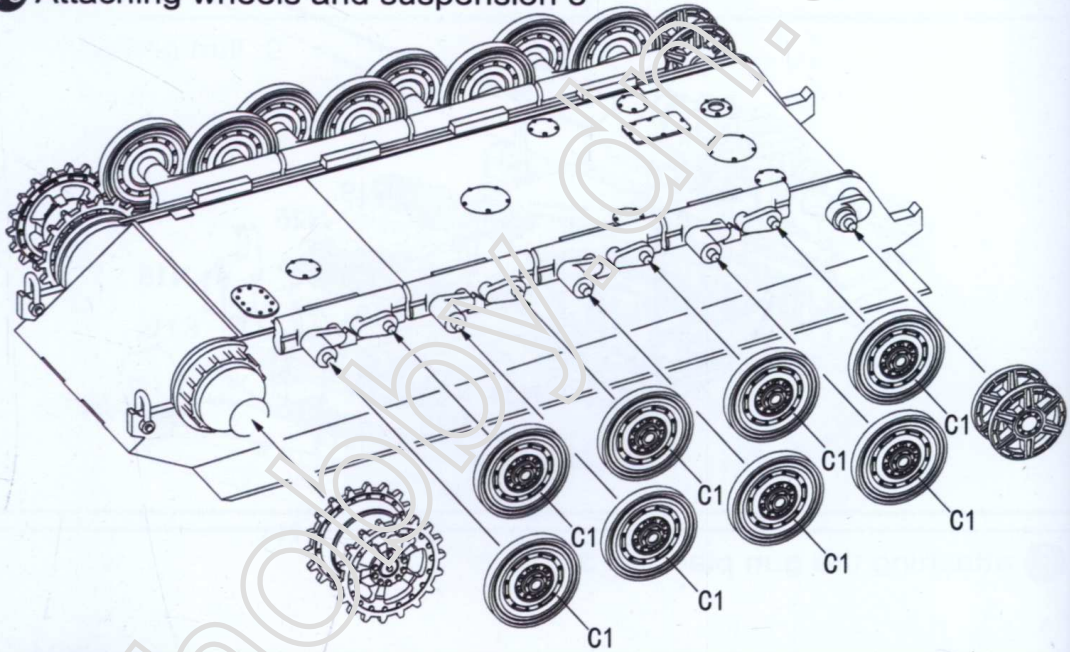

14 Attaching hull

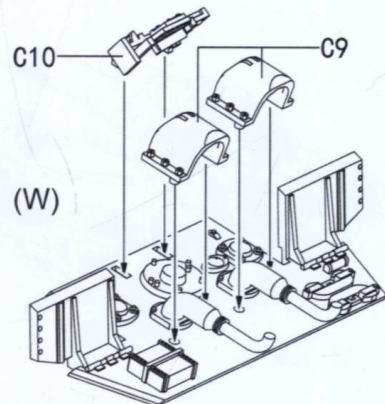
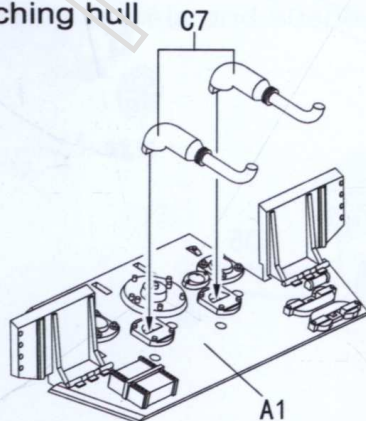

15 Attaching tracks

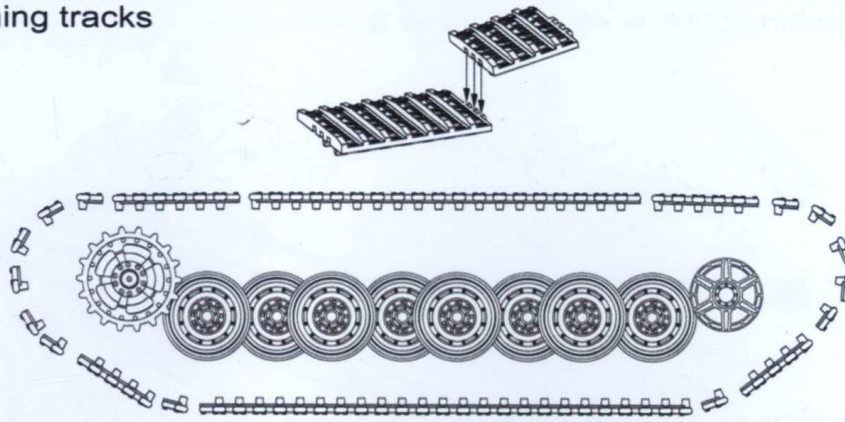

16 Attaching engine 1

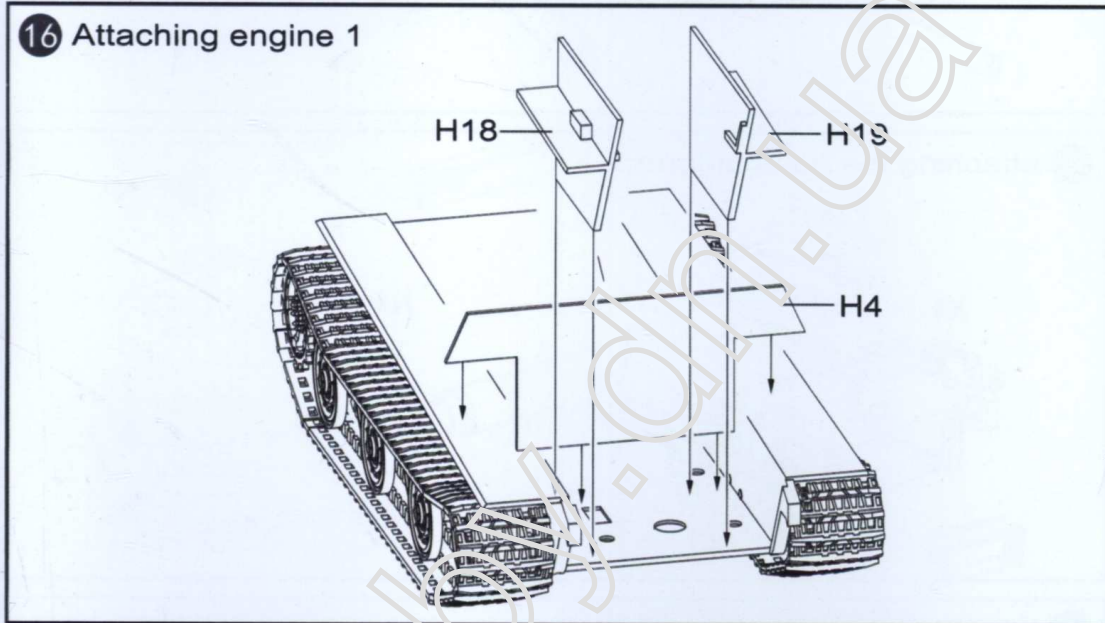

17 Attaching engine 2

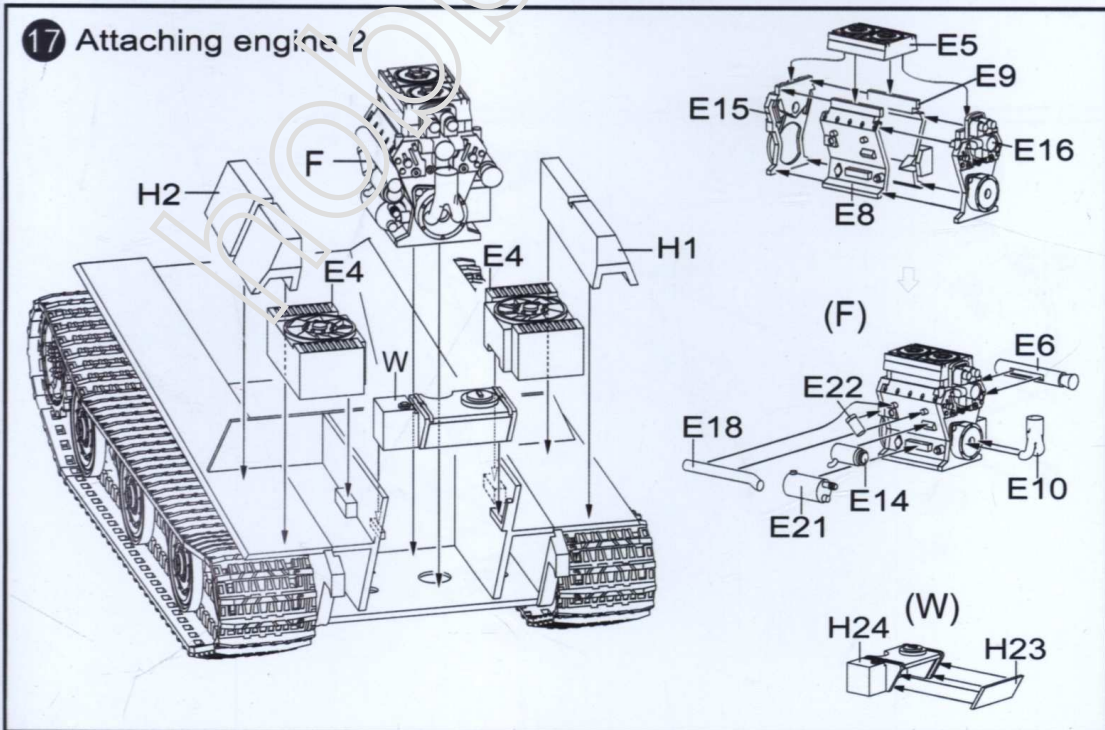

18 Attaching hull

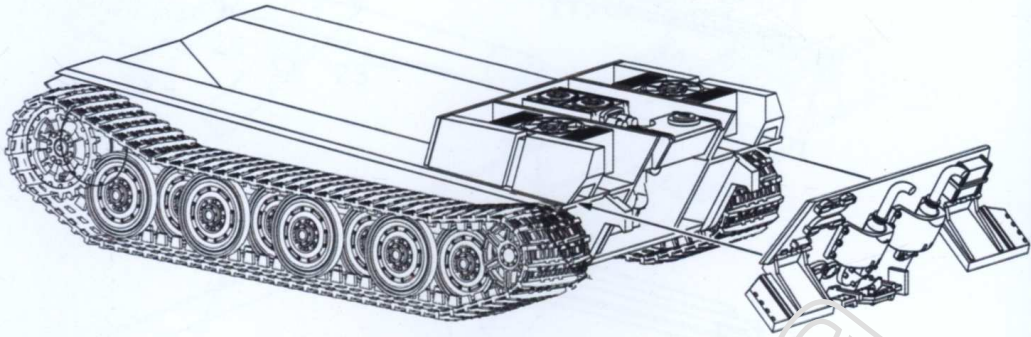

19 Attaching turret and hull

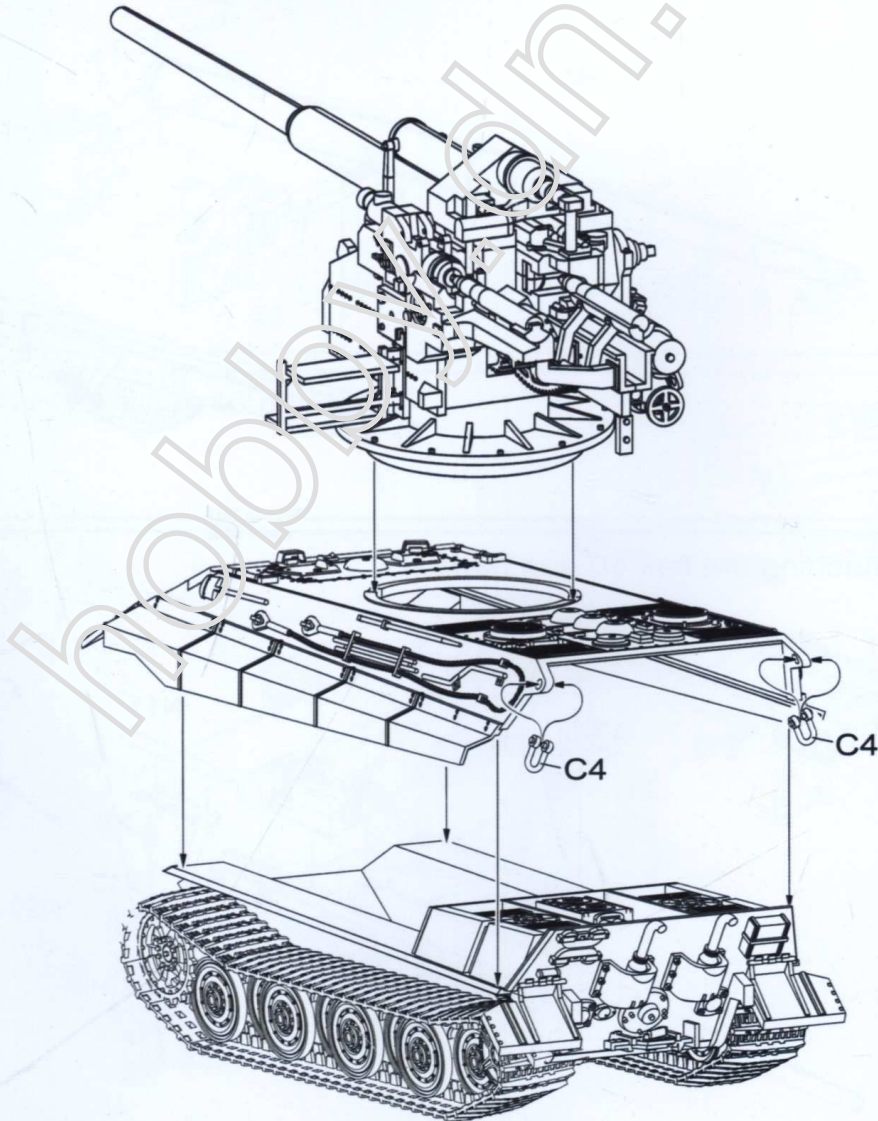

GERMANY WWII E-75 HEAVY TANK WITH 128MM FLAK 40 GUN

modelcollect

A.MIG 011 RAL 7028
DUNKELGELB AUS 44 DG I

A.MIG 014 RAL 8012 ROTBRAUN

A.MIG 003 RAL 6011 RESEDAGRÜN

A.MIG 033 Rubber & Tires

A.MIG 045 GUN METAL

A.MIG 099 CRYSTAL SMOKE

A.MIG 037 NEW WOOD

A.MIG 008 Dark grey

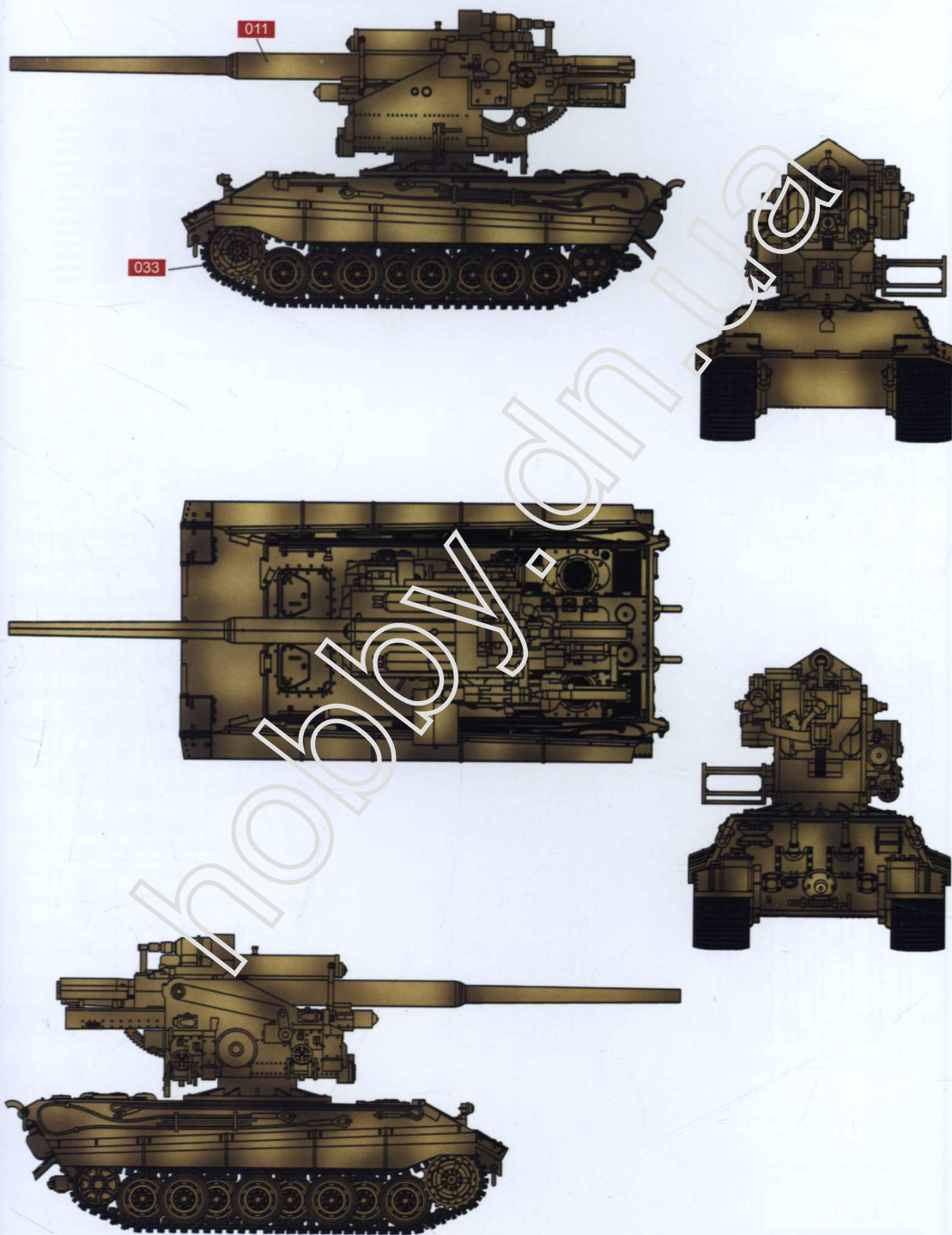

MODELCOLLECT

Color info and profiles by



GERMANY WWII E-75 HEAVY TANK WITH 128MM FLAK 40 GUN

modelcollect

A.MIG 011 RAL 7028 DUNKELGELB/BAUS '44 DG 1

A.MIG 014 RAL 8012 ROTBRAUN

A.MIG 003 RAL 6011 RESEDAGRÜN

A.MIG 033 Rubber & Tires

A.MIG 045 GUN METAL

A.MIG 095 CRYSTAL SMOKE

A.MIG 037 NEW WOOD

A.MIG 008 Dark gray

