

WWII GERMAN 38CM ASSAULT MORTAR STURM E75



ITEM NO:UA72140

The E-50 Standardpanzer was intended as a standard medium tank, replacing the Panther and Tiger I and the conversions based on these tanks. The E-50 hull was to be longer than the Panther, in fact it was practically identical to the Königstiger (Tiger II) in overall dimensions except for the glacis plate layout. Compared to these earlier designs however, the amount of drilling and machining involved in producing these Standardpanzer was reduced drastically, which would have made them quicker, easier and cheaper to produce, as would the proposed conical spring system, replacing their predecessors' torsion bar system which required a special steel alloy.

Other sources show that a variant of the narrow-mantlet 'Schmalturn' turret designed for the Panther Ausf. F would have been used, coupled with a variant of the 88 mm L/71 gun.

As indicated by its name, the weight of the E-50 would fall between 50 and 75 tonnes. The engine was an improved Maybach HL234 which had 900 hp. Maximum speed was supposed to be 60 km/h.

●READ BEFORE ASSEMBLY

1. When you use glue or paint, do not near flame, and use in a well-ventilated room.
2. Take extra care in handling photo etch parts in order to avoid injury.
3. When you take parts off the runner frame, use modeling scissors and trim excess plastic with a cutter or a file.
4. Glue and paint are not included.
5. This product is only suitable for experienced more than 14 years old.

●装配之前仔细阅读:

1. 勿於近火处使用胶水或油漆, 并 打开窗户保持空气流通。
2. 取蚀刻片时应特别注意安全, 防止利边划伤手指。
3. 从胶架中取出部件时, 应用模型专用剪, 并用界刀或小锉除去多余的胶料。
4. 请使用塑料胶水和油漆, 模型内不含。
5. 本产品不适合14岁以下没有经验的模型爱好者。



SUPERGLUE
强力胶



WEIGHT
重量

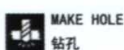

MAKE HOLE
钻孔



CUT/REMOVE
切除



BEND
弯曲



FILE/SAND
锉平

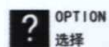

OPTION
选择



NO CEMENT
不涂胶水



DECAL
贴纸

DECAL APPLICATION

1. Cut off decal from sheet.
2. Dip the decal in tepid water 40° C for about 10 sec. and place on a clean cloth.
3. Hold the backing sheet edge and slide decal onto the model.
4. Move decal into position by wetting decal with finger.
5. Press decal gently down with a soft cloth until excess water and air bubbles are gone.

水贴纸的使用:

1. 从水贴纸剪下印花。
2. 将印花放入温水中浸10秒, 然后放在干净布上。
3. 拿着印花纸板将印花移到模型上。
4. 手指蘸水将印花移到适当的位置。
5. 用软布轻压印花直至不干, 汽泡消失。

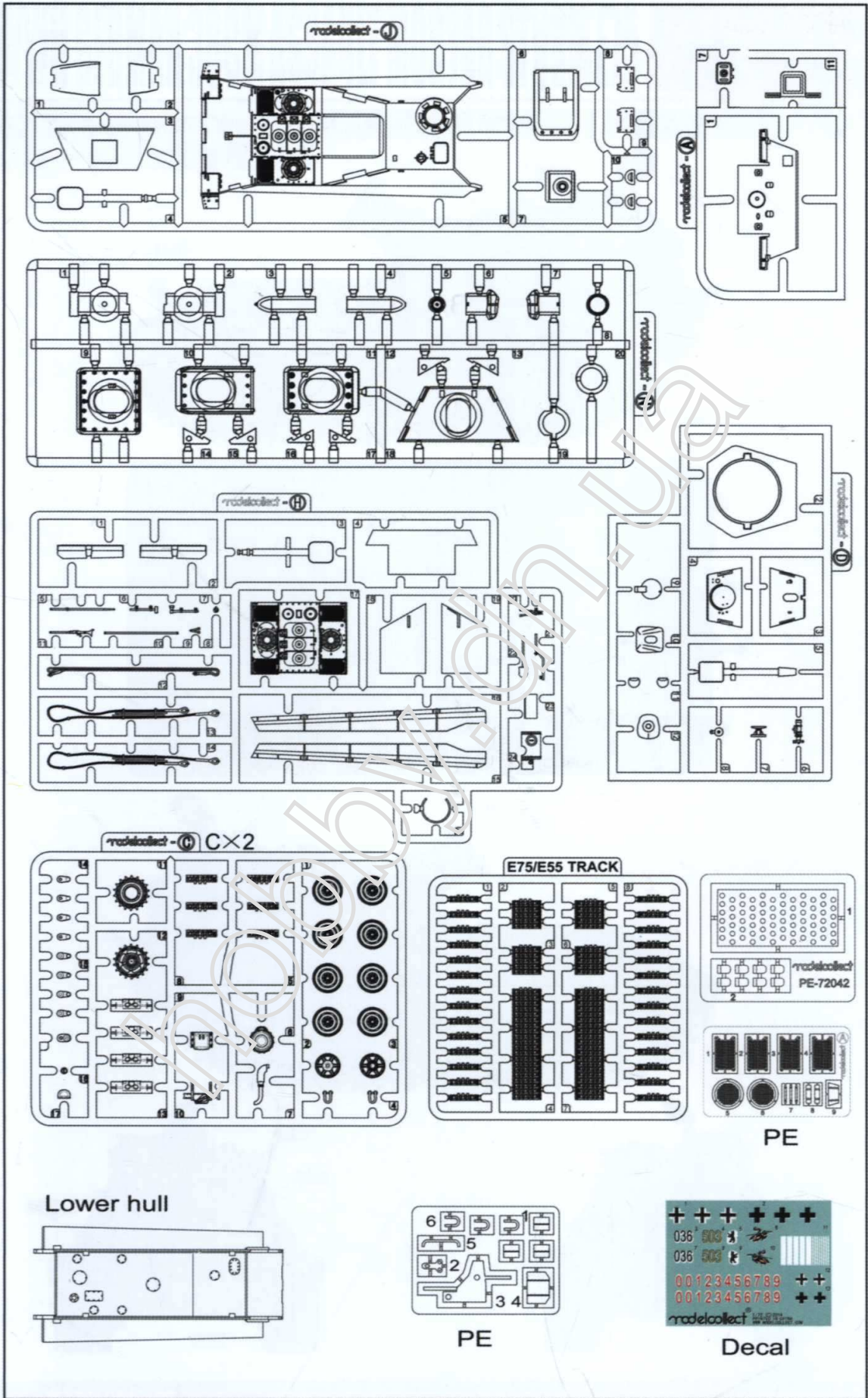

1 組裝炮塔1
Attaching turret parts 1

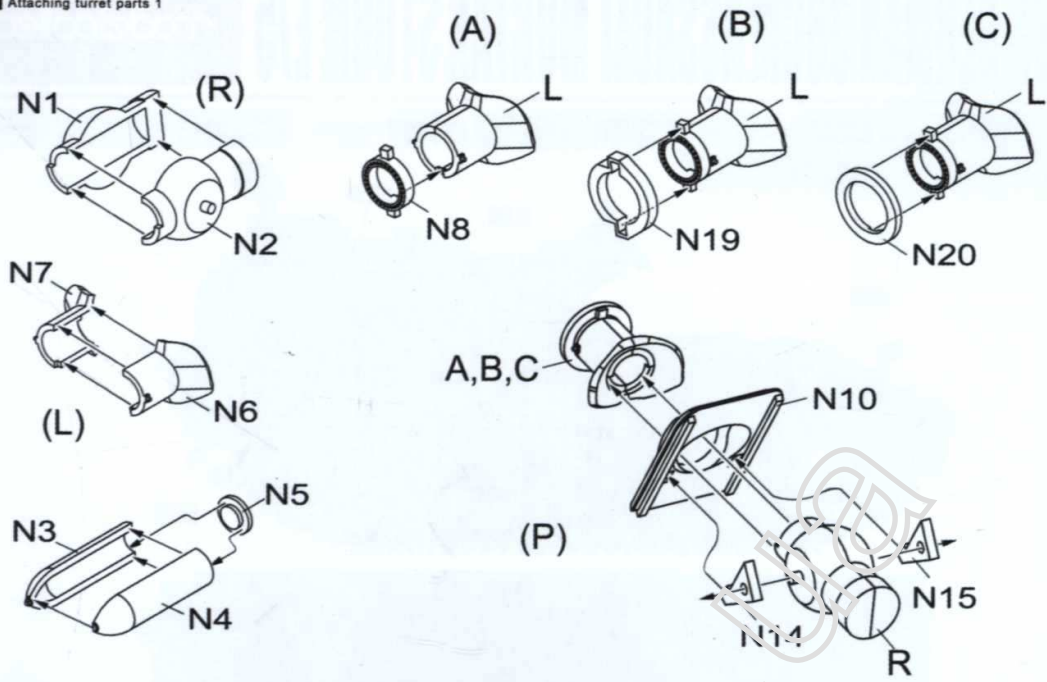

2 組裝炮塔2
Attaching turret parts 2

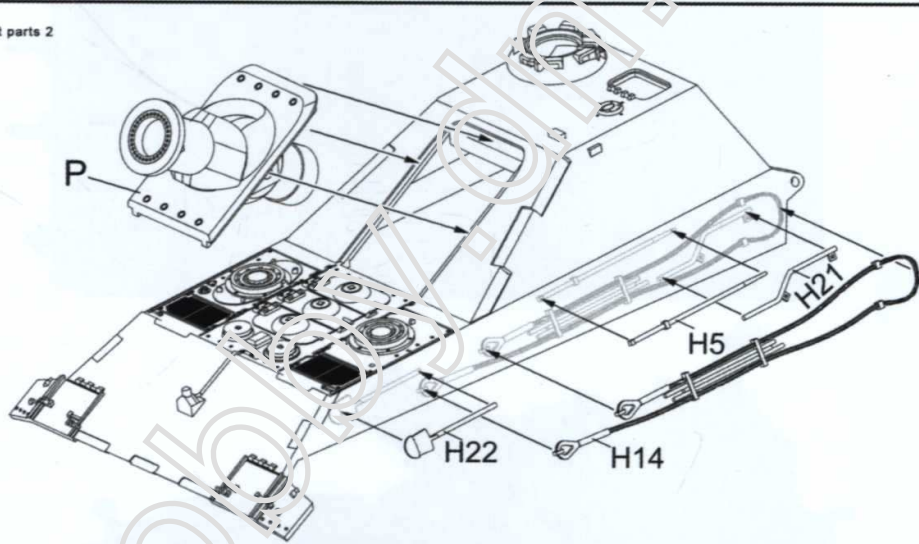

3 組裝炮塔3
Attaching turret parts 3

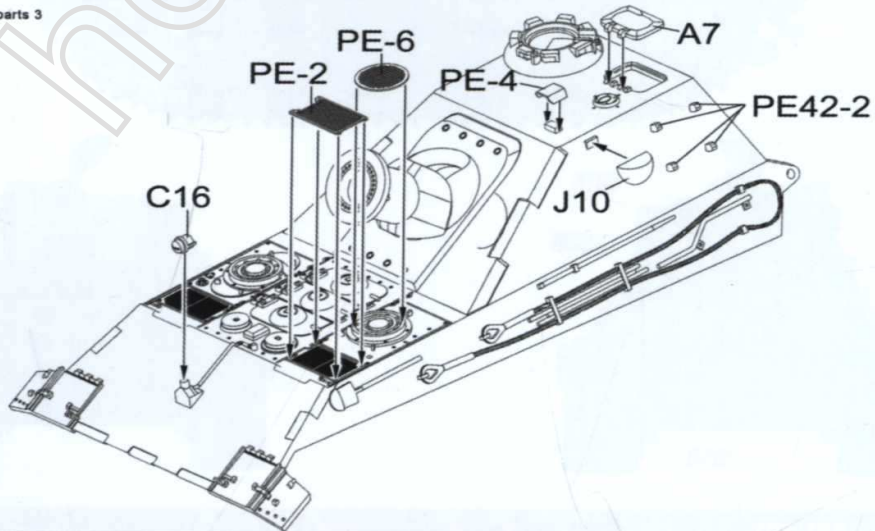

4 组装车体1
Attaching hull 1

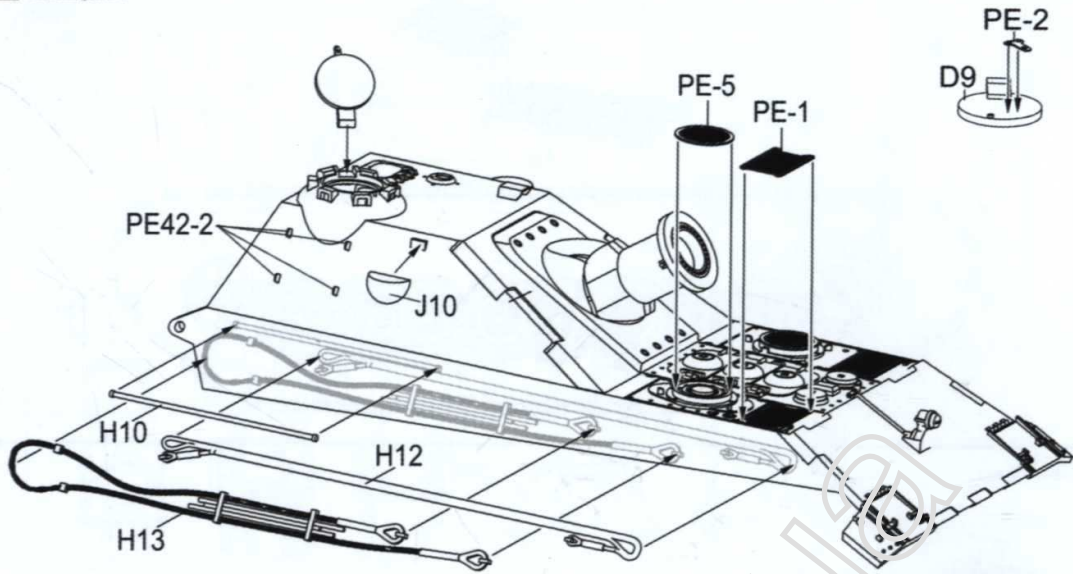

5 组装车体2
Attaching hull 2

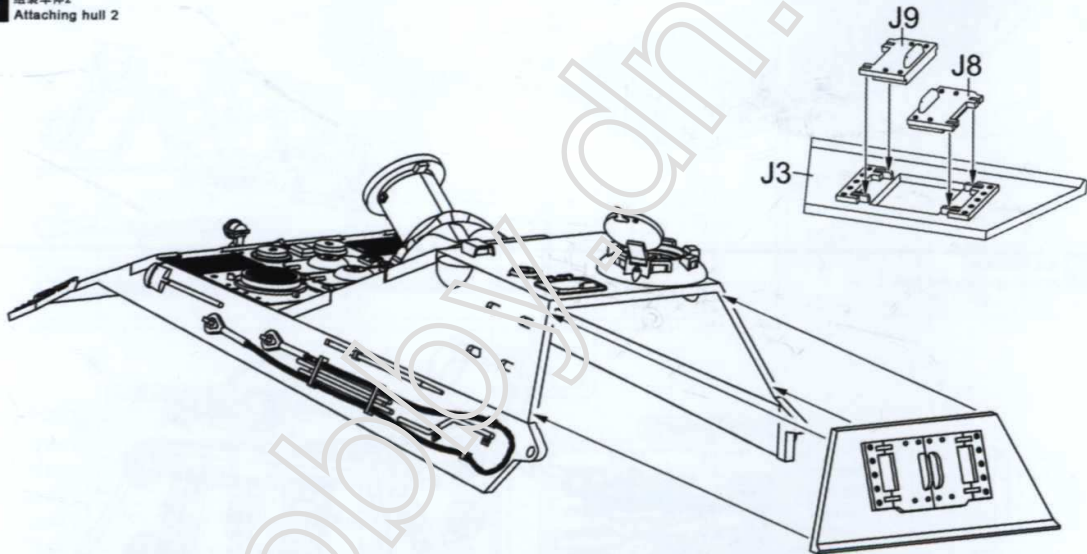

6 组装车轮和悬挂1
Attaching wheels and suspension 1

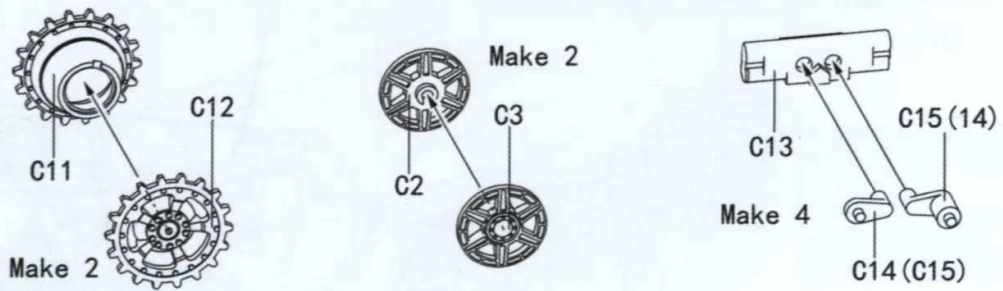

7 组装车轮和悬挂2
Attaching wheels and suspension 2

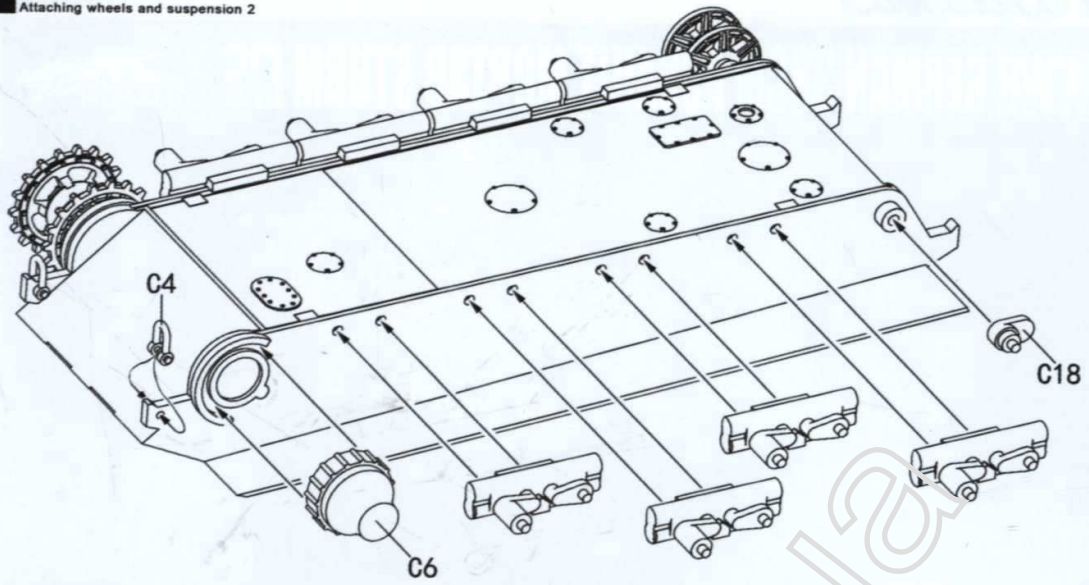

8 组装车轮和悬挂3
Attaching wheels and suspension 3

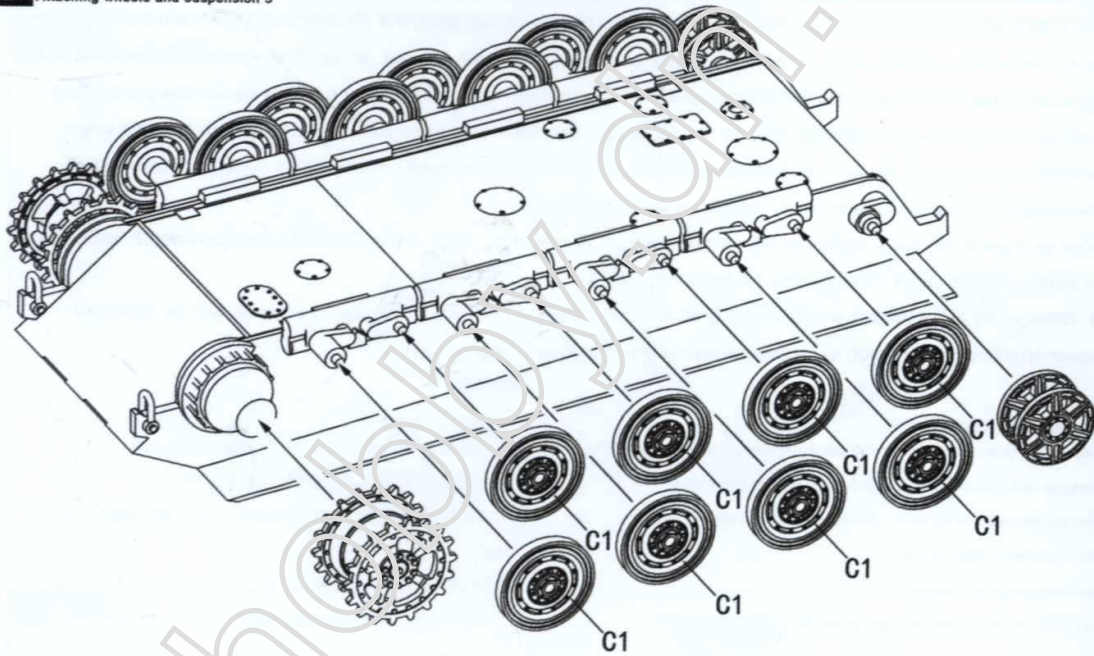

9 组装车座
Attaching hull

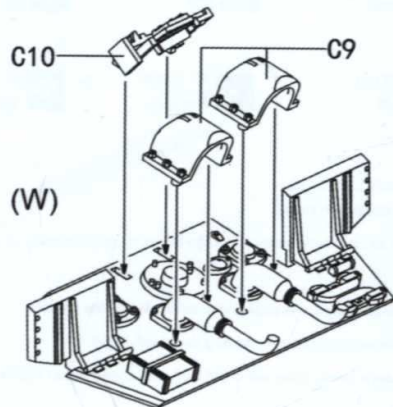
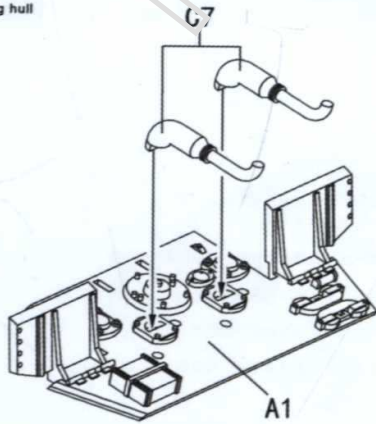

10 组装拼接履带
Attaching tracks

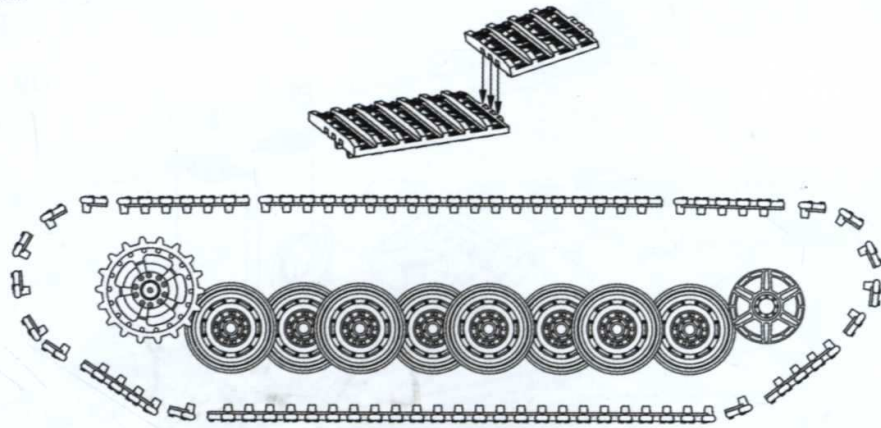

11 组装车体
Attaching hull

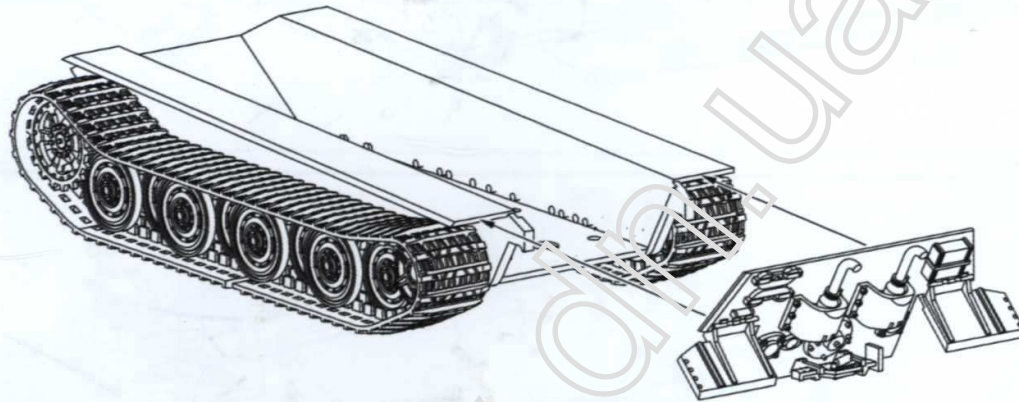

12 组装炮塔和车体
Attaching turret and hull

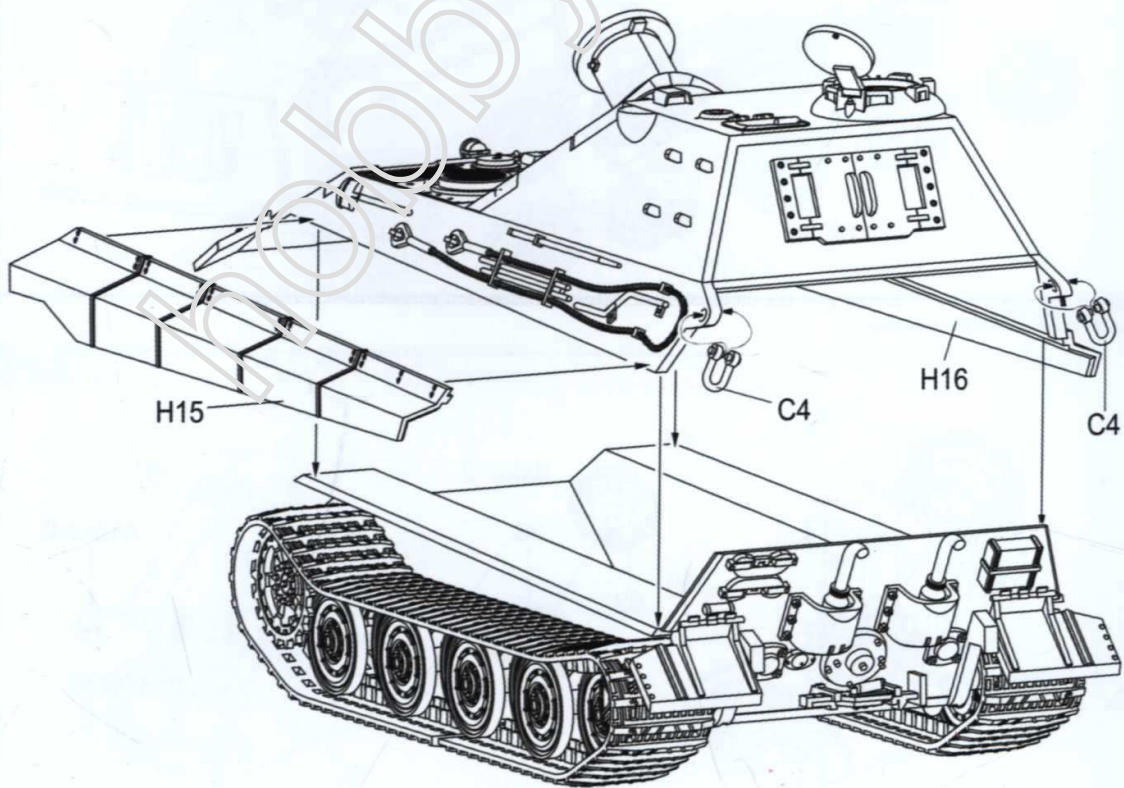

WWII GERMAN 38CM ASSAULT MORTAR STURM E75

modelcollect

A.MIG 011	RAL 7025 DUNKELGELB AUS '44 DG I	A.MIG 014	RAL 8012 ROTBRAUN	A.MIG 003	RAL 6011 RESEDAGRÜN	A.MIG 035	DARK TRACKS	A.MIG 045	GUN METAL	A.MIG 095	CRYSTAL SMOKE
A.MIG 037	NEW WOOD	A.MIG 192	POLISHED METAL								

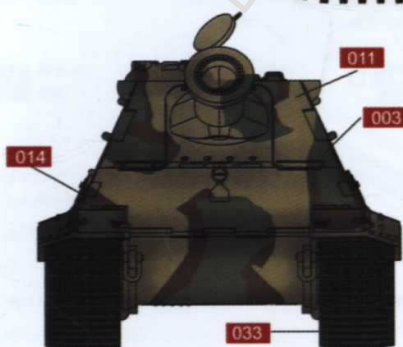
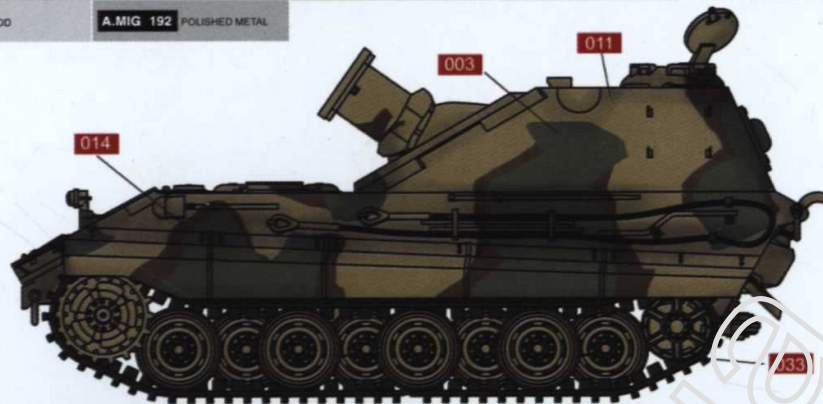

modelcollect

hobbyjahn.ua